

V600 ID System Hand-held Reader Writer

Operation Manual

Cat. No. Z122-E3-1

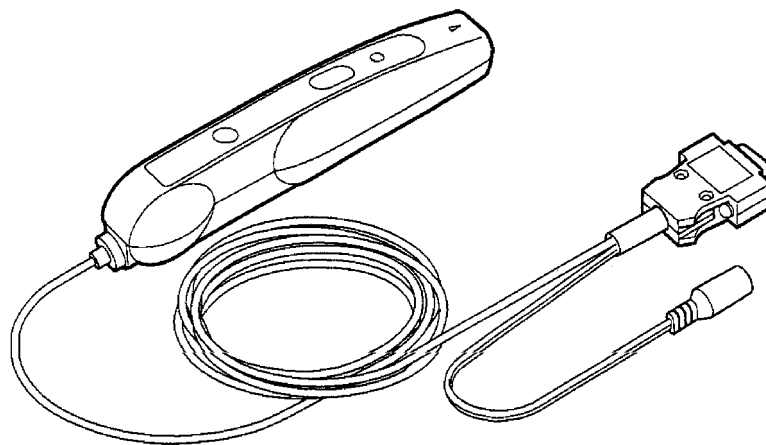

Notice:

OMRON products are manufactured for use according to proper procedures by a qualified operator and only for the purposes described in this manual.

Follow the precautions below. Otherwise damage may occur to the Unit.

1. Do not use submersed in water or in a high-water-pressure environment.
2. Do not expose the antenna section of the Handheld Reader Writer to excessive shocks.
3. Do not place excessive strain on the cables by pulling them.
4. Do not press on the activate switch with your nail.
5. Do not use any AC adapters other then the designated one.
6. Do not use in locations when it may be subject to oils or chemicals.

The following conventions are used to indicate and classify precautions in this manual. Always heed the information provided with them. Failure to heed precautions can result in injury to people or damage to the product.

 **DANGER** Indicates an imminently hazardous situation which, if not avoided, will result in death or serious injury.

 **WARNING** Indicates a potentially hazardous situation which, if not avoided, could result in death or serious injury.

 **Caution** Indicates a potentially hazardous situation which, if not avoided, may result in minor or moderate injury, or property damage.

OMRON Product References

All OMRON products are capitalized in this manual. The word “Unit” is also capitalized when it refers to an OMRON product, regardless of whether or not it appears in the proper name of the product.

The abbreviation “Ch,” which appears in some displays and on some OMRON products, often means “word” and is abbreviated “Wd” in documentation in this sense.

The abbreviation “PC” means Programmable Controller and is not used as an abbreviation for anything else.

Visual Aids

The following headings appear in the left column of the manual to help you locate different types of information.

Note Indicates information of particular interest for efficient and convenient operation of the product.

1, 2, 3... 1. Indicates lists of one sort or another, such as procedures, checklists, etc.

© OMRON, 1998

All rights reserved. No part of this publication may be reproduced, stored in a retrieval system, or transmitted, in any form, or by any means, mechanical, electronic, photocopying, recording, or otherwise, without the prior written permission of OMRON.

No patent liability is assumed with respect to the use of the information contained herein. Moreover, because OMRON is constantly striving to improve its high-quality products, the information contained in this manual is subject to change without notice. Every precaution has been taken in the preparation of this manual. Nevertheless, OMRON assumes no responsibility for errors or omissions. Neither is any liability assumed for damages resulting from the use of the information contained in this publication.

Standard Conformity:

1. FCC Rules (Federal Communications Commission)

This Product complies with Part 15 Subpart C of the FCC Rules. □
FCC ID: E4E6CYCIDV6000203

FCC NOTICE

This equipment has been tested and found to comply with the limits for a Class A digital device, pursuant to □ part 15 of the FCC Rules. These limits are designed to provide reasonable protection against harmful □ interference when the equipment is operated in a commercial environment. This equipment generates, uses, □ and can radiate radio frequency energy and, if not installed and used in accordance with the instruction □ manual, may cause harmful interference to radio communications. Operation of this equipment in a □ residential area is likely to cause harmful interference in which case the user will be required to correct the □ interference at his own expense.

FCC WARNING

Changes or modifications not expressly approved by the party responsible for compliance could void the □ user's authority to operate the equipment. □

□

Properly shielded an grounded cables and connectors must be used for connection to host computer and / or □ peripherals in order to meet FCC emission limits. AC adaptor with ferrite core must be used for RF □ interference suppression. □

□

TABLE OF CONTENTS

SECTION 1

Features and System Configuration 1

- 1-1 Features 2
- 1-2 System Configuration 3
- 1-3 Overview of System Operation 4

SECTION 2

Specifications and Performance 5

- 2-1 Names and Functions of Components 6
- 2-2 Specifications 7
- 2-3 Dimensions 8
- 2-4 Communications Specifications 8
- 2-5 Host Interface Connector Pin Layout 9
- 2-6 Transmission Specifications 9
- 2-7 Hand-held Reader Writer Functions 12
- 2-8 Hand-held Reader Writer Settings 16
- 2-9 Data Carrier 17

SECTION 3

Host Communications 27

- 3-1 Command/Response Format 28
- 3-2 Command Format 32
- 3-3 End Code List 48
- 3-4 Communications Time 48

SECTION 4

Using the Hand-held Reader Writer 51

- 4-1 Connection with the Host Device 52
- 4-2 Communications Program Example 53

SECTION 5

Troubleshooting 55

- 5-1 Error Table 56
- 5-2 Troubleshooting Flowchart 57

Appendices

- A JIS 8 Code List (ASCII List) 59
- B Data Carrier Memory Capacity and Memory Type 61

Index 63

Revision History 65

About this Manual:

This manual describes the installation and operation of the V600 Hand-held Reader Writer and includes the sections described below.

Please read this manual carefully and be sure you understand the information provided before attempting to install and operate the Hand-held Reader Writer.

Section 1 describes the features and system configuration of the Hand-held Reader Writer.

Section 2 provides information on the specifications and functions of the Hand-held Reader Writer.

Section 3 describes the command and response formats for communications between the host device and the Hand-held Reader Writer.

Section 4 explains how to connect the Hand-held Reader Writer to a host device and provides a communications program example.

Section 5 gives details on the types of errors that can occur and provides troubleshooting flow charts.

Appendix A provides a JIS 8 code list (ASCII code list).

Appendix B provides a Data Carrier memory capacity and memory type table.

 **WARNING** Failure to read and understand the information provided in this manual may result in personal injury or death, damage to the product, or product failure. Please read each section in its entirety and be sure you understand the information provided in the section and related sections before attempting any of the procedures or operations given.

SECTION 1

Features and System Configuration

This section describes the features and system configuration of the Hand-held Reader Writer.

1-1	Features	2
1-2	System Configuration	3
1-3	Overview of System Operation	4

1-1 Features

A compact, lightweight V600-CH1D Hand-held Reader Writer with superior operating capability.

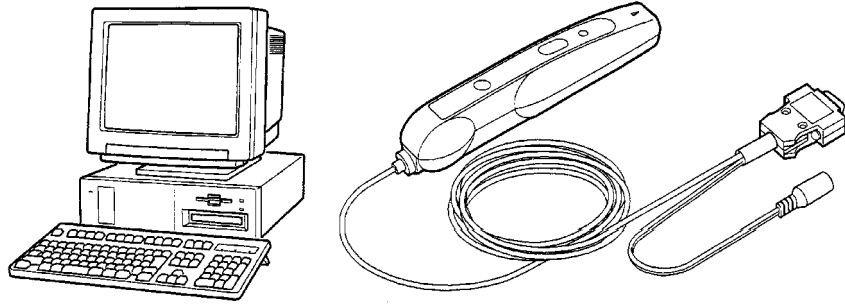

IBM PC/AT or Compatible Computer

V600-CH1D
Hand-held Reader Writer

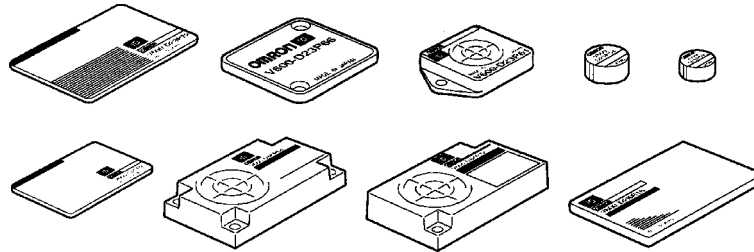

Data Carrier

- Data can be read and written from the Data Carrier simply by placing the Hand-held Reader Writer within range or by touching the Data Carrier.
- The Hand-held Reader Writer can be used in moist places due to IEC standard IP63 and JIS standard IPX3 (moisture-tight).
- The V600-CH1D has a built-in RS-232C interface, and can be connected to a IBM PC/AT or compatible computer, PC, or other control devices.

1-2 System Configuration

The V600-CH1D Hand-held Reader Writer can communicate with PCs and portable devices that have an RS-232C, using an in-built serial interface based on the RS-232C.

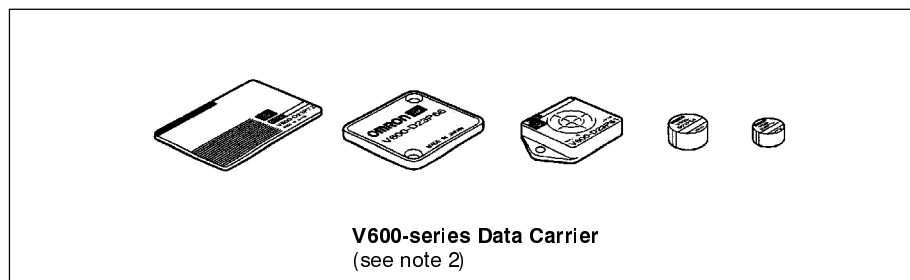
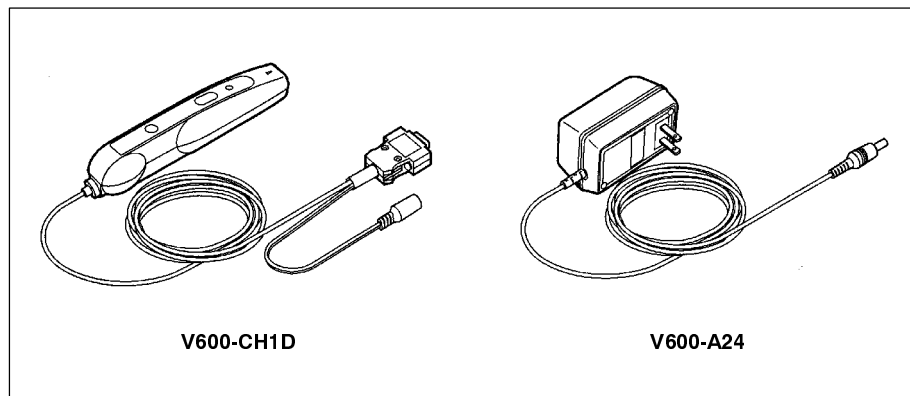
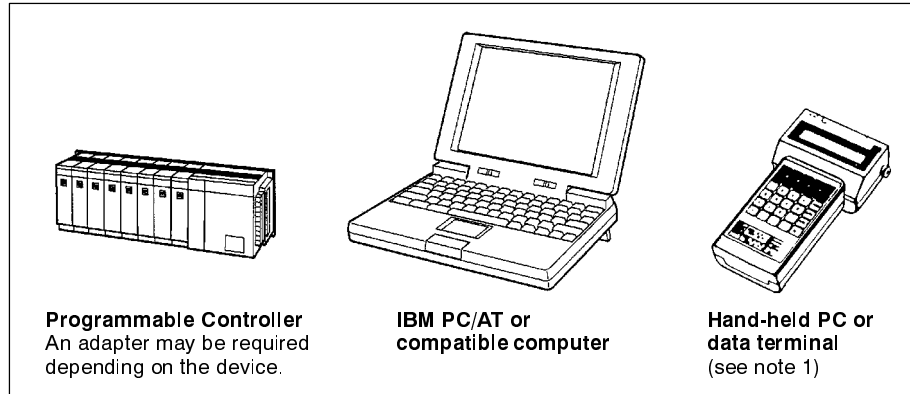

- Note**
1. Limited to devices in which power can be supplied from the Hand-held PC to the Hand-held Reader Writer.
 2. The Hand-held Reader Writer is able to use any Data Carrier in the V600 Series.

1-3 Overview of System Operation

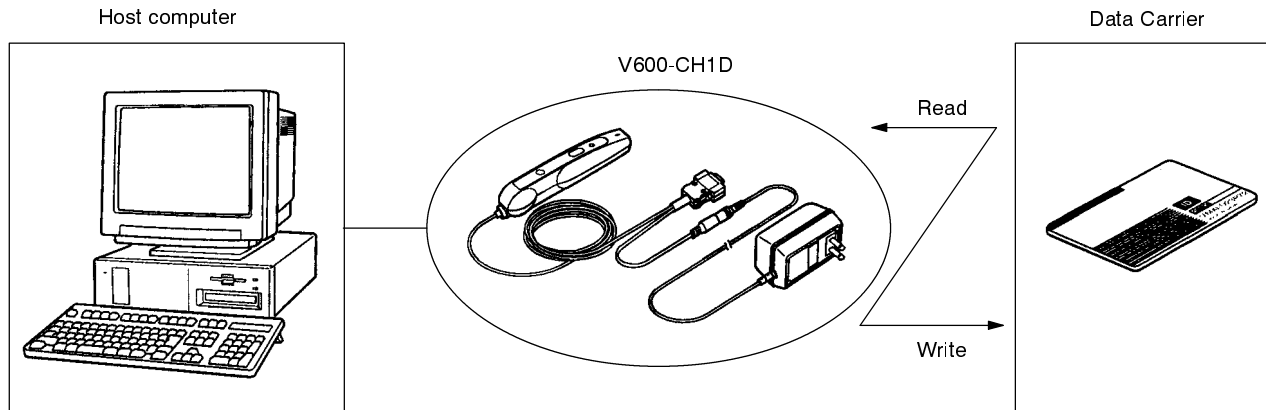

1, 2, 3...

1. A command specifying the memory area of the host device to be read (such as a PC or Hand-held ID Controller) is sent.
2. As the Hand-held Reader Writer approaches the Data Carrier and enters the communications range, the memory contents specified by the Data Carrier are read and a response is issued to the host device.
3. The data received is displayed.

Note A communications program must be pre-installed in the host device in order to use the Hand-held Reader Writer.

SECTION 2

Specifications and Performance

This section describes the specifications and functions of the Hand-held Reader Writer.



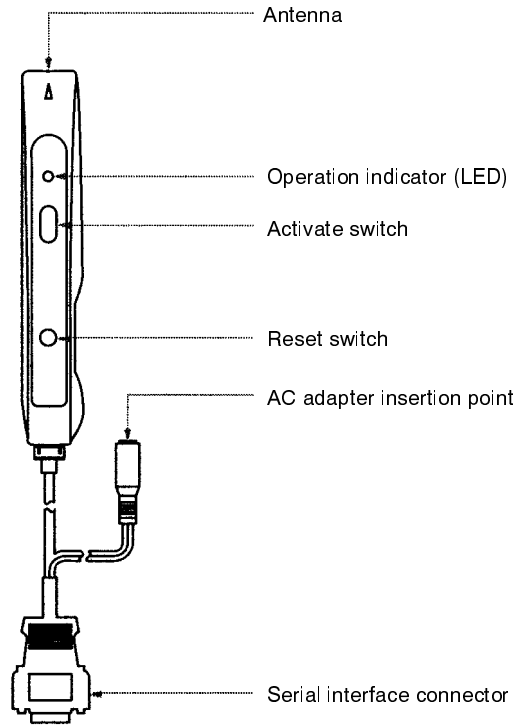

2-1	Names and Functions of Components	6
2-2	Specifications	7
2-2-1	General	7
2-2-2	Characteristics	7
2-2-3	Specifications Required for Optional AC Adapter	7
2-3	Dimensions	8
2-4	Communications Specifications	8
2-4-1	Host Communications Interface Specifications	8
2-5	Host Interface Connector Pin Layout	9
2-6	Transmission Specifications	9
2-6-1	Transmission Distances	9
2-6-2	Transmission Range	11
2-7	Hand-held Reader Writer Functions	12
2-7-1	Communications with the Data Carrier	12
2-7-2	Multiple Area Control	15
2-7-3	Auto Command Off	15
2-7-4	Normal Operation Output	16
2-8	Hand-held Reader Writer Settings	16
2-8-1	Settings	16
2-8-2	Reading the Setting Conditions	16
2-8-3	Initializing Setting Conditions	17
2-9	Data Carrier	17
2-9-1	Memory Map	17
2-9-2	Manufacturing Date Format (Default Setting)	18
2-9-3	Write-Protect Function	18
2-9-4	Detecting Function of Data Carrier Life	22
2-9-5	Memory Check Function in Data Carrier	24

2-1 Names and Functions of Components

V600-CH1D Hand-held Reader Writer



Operation Indicators (LED)

Indicator	Contents
 Green light lit	Indicates communications stand-by status with the Data Carrier when a command is received from the host device. Light goes out once communications are complete.
 Green light flashing	Flashes while the Reader Writer is in stand-by status in order to initialize the preset contents as a result of activating the reset switch. Flashes for a maximum of 30 seconds.
 Red light lit	Lit when an operation halted error (CPU or memory error) is generated. Released when the power is reset.
 Red light flashing	Flashes when errors in communications occur with the Data Carrier or with the host device. Flashes for a maximum of 2 seconds.

Activate Switch

When button commands (button commands, button auto commands) are used and the activate switch is pressed, communications with the Data Carrier will commence. (Refer to *Section 3 Host Communications* for more details on button commands.) If the activate switch is pressed in the settings initialization stand-by state to initialize the setting (green LED flashing), the Hand-held Reader Writer function settings will be initialized.

Reset Switch

If the reset switch is held for 2 seconds or more during startup, the Hand-held Reader Writer will go into stand-by state to initialize the setting.

AC Adapter Insertion Point	This is a dedicated AC adapter connection jack.
Serial Interface Connector	This is a 9-pin D-sub connector serial interface based on RS-232C.
Antenna	To communicate with the Data Carrier, move the antenna section closer to it.

2-2 Specifications

2-2-1 General

Item	Specifications
Power supply voltage	5 VDC from AC Adapter (requires EIAJ Class 2 plug)
Permissible power supply voltage	5 VDC \pm 5%
Current consumption	200 mA max. (see note 1)
Insulation resistance	50 M Ω min. (by 500 VDC mega-ohm meter) between cable terminals and case
Dielectric strength	1,000 VAC, 50/60 Hz for 1 min (1 mA max.) between cable terminals and case
Noise immunity	Power supply line: \pm 1,200 Vp-p I/O line: \pm 800 Vp-p
Vibration resistance	Destruction: 10 to 150 Hz, 0.3-mm single amplitude, with 4 sweeps of 8 min each in 3 directions
Shock resistance	Destruction: 294 m/s ² (approx. 20G), 3 times each in 3 directions
Ambient temperature	Operating: -10°C to 55°C Storage: -25°C to 65°C
Ambient operating humidity	35% to 85% (with no condensation)
Ambient atmosphere	No corrosive gasses
Enclosure ratings	IEC: IP63; JIS: IPX3 (waterproof) (see note 2)
Material	ABS resin (case), PET resin (nameplate)
Cable length	2.5 m
Weight	Approx. 180 g (including connector and cable)

- Note**
1. This figure is for idling or stand-by. The inrush current must be 250 mA maximum.
 2. This does not include the connector section. The main unit is not resistant to chemicals or oils.

2-2-2 Characteristics

Item	Specifications
Diagnostic functions	Checks for CPU errors, memory errors, and transmission errors.

2-2-3 Specifications Required for Optional AC Adapter

Item	Specification
Output voltage	5 VDC \pm 5%
Current consumption	250 mA

2-3 Dimensions

V600-CH1D Reader Writer

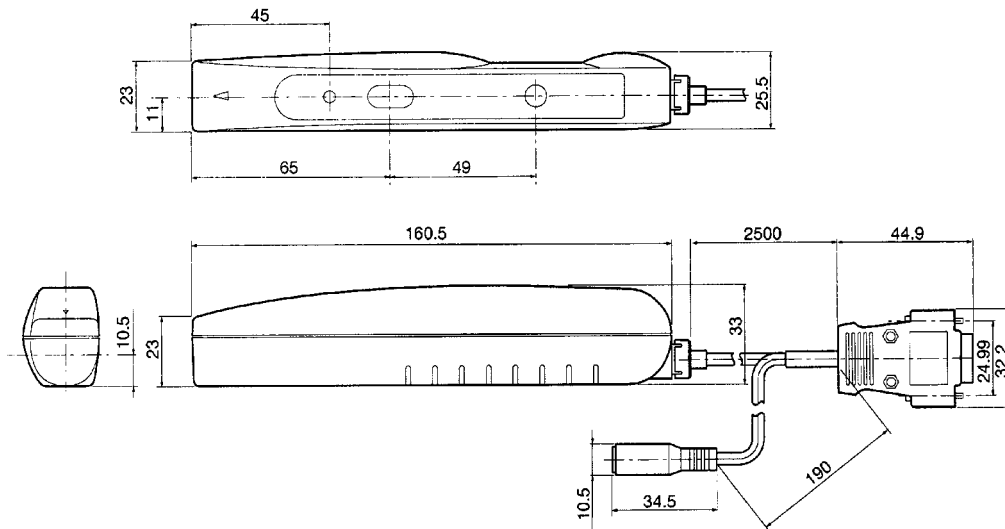

2-4 Communications Specifications

2-4-1 Host Communications Interface Specifications

Item	Specifications
Connectors	9-pin D-sub female connector (IBM PC/AT or compatible)
Standard	RS-232C
Transmission connection	1:1
Communications method	2-wire, half duplex
Synchronization method	Start-stop (stop bits: 1 or 2) (see note)
Baud rate	2,400 / 4,800 / 9,600 / 19,200 bps (see note)
Transmission code	ASCII (7-bit) or 8-bit JIS code (see note)
Transmission control protocol	1:1
Error detection	Vertical parity (even, odd, none) (see note)

Note These are to be set according to the SETTING command issued from the host unit.

2-5 Host Interface Connector Pin Layout

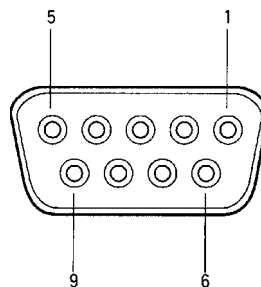

(Diagram viewed from the insertion point.)

Pin No.	Abbreviation	Description	Signal direction
1			
2	SD	Send data	Brown
3	RD	Receive data	Red
4			
5	SG	Signal ground	Blue
6	RS	Request to send	Gray
7	CS	Clear to send	Orange
8	CS	Clear to send	Orange
9			

2-6 Transmission Specifications

Transmission with the currently available V600-series Data Carriers is possible.

2-6-1 Transmission Distances

Data Carrier	Transmission distances
V600-D23P53	0 to 2.5 mm
V600-D23P54	0 to 4 mm
V600-D23P61	0 to 11 mm
V600-D23P66	0 to 17 mm (see note 2)
V600-D23P66SP	0 to 12 mm
V600-D23P71	0 to 25 mm
V600-D23P72	0 to 23 mm
V600-D8KR04	0 to 35 mm
V600-D8KR12	0 to 25 mm
V600-D8KR13	0 to 20 mm
V600-D2KR16	0 to 10 mm

- Note** 1. Data Carrier Installation Conditions
- V600-D23P53/P54: Embedded in iron.
 - V600-D23P61: Metal (iron) on the back surface of the Data Carrier.
 - V600-D23P66/P66SP/P71/P72: No metal on the back surface of the Data Carrier.
 - V600-D8KR04/R12/R13: Metal (iron) on the back surface of the Data Carrier.
 - V600-D2KR16: Data Carrier installed on a bracket (V600-A81) and attached to a metal (aluminium) plate.

-
2. When using the V600-D23P66 at temperatures lower than -10°C , transmission may not be possible at the specified distance. In this case, move the Reader Writer away from the Data Carrier.

2-6-2 Transmission Range

V600-D23P53

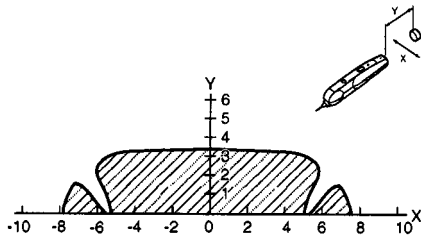

V600-D23P54

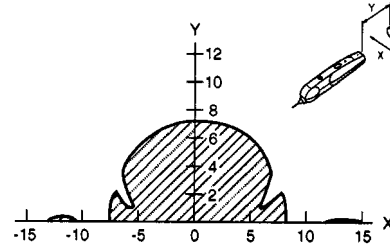

V600-D23P61

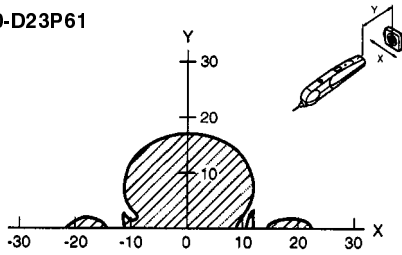

V600-D23P66

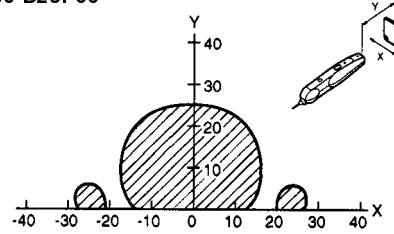

V600-D23P66SP

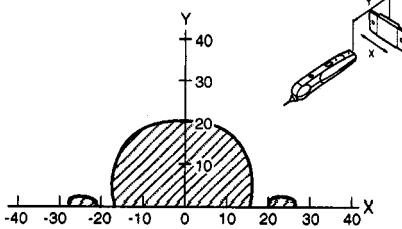

V600-D23P71

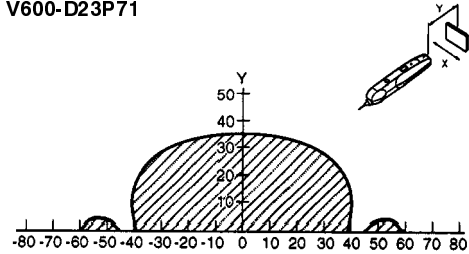

V600-D23P72

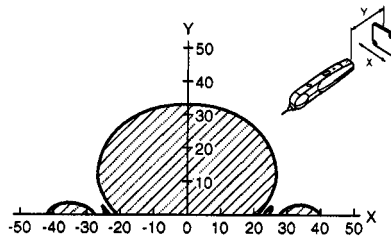

V600-D8KR12

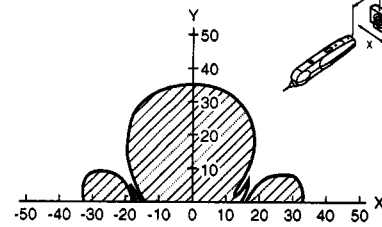

V600-D8KR13

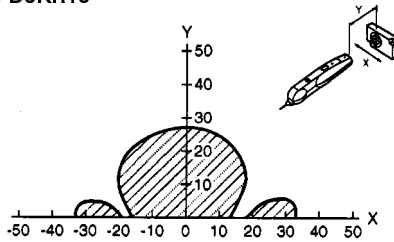

V600-D8KR04

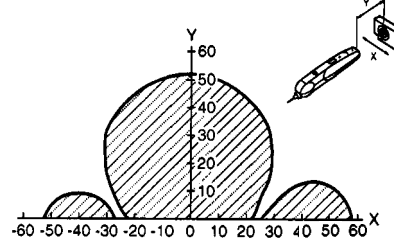

V600-D2KR16

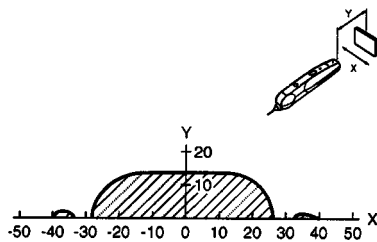

(Unit: mm)

2-7 Hand-held Reader Writer Functions

2-7-1 Communications with the Data Carrier

There are 4 types of commands for communicating with the Data Carrier using the Hand-held Reader Writer.

- Normal commands
- Button commands
- Auto commands
- Button auto commands

Normal Commands

Normal commands are sent from the host device for communications with the Data Carrier, after the antenna section of the Hand-held Reader Writer have been brought close to the Data Carrier. If the antenna is not in front of the Data Carrier when a command is sent from the host device, a "Data Carrier non-existent error" will result.

- 1, 2, 3...** 1. Place the antenna of the Hand-held Reader Writer near the Data Carrier.

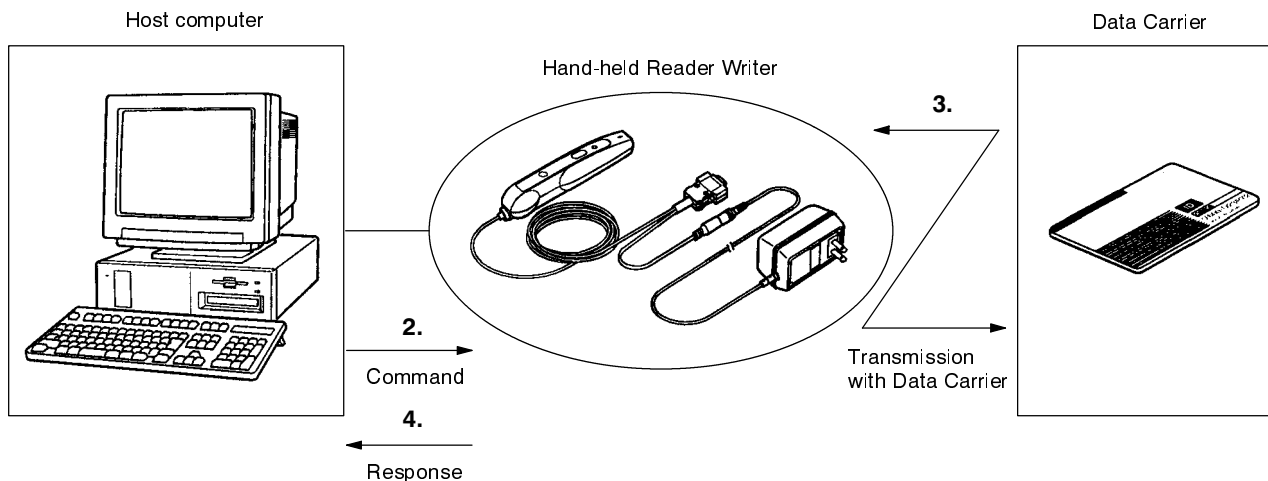
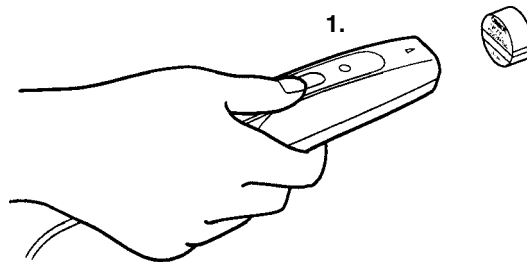

2. Commands are sent from the host device to the Hand-held Reader Writer.
3. The Hand-held Reader Writer communicates with the Data Carrier. The operation indicator is lit green.
4. A response is given from the Hand-held Reader Writer to the host device. The operation indicator (LED) is not lit.

Button Commands

Button commands for communications with the Data Carrier are activated when the activate switch is pressed after commands are sent from the host device, and the antenna section of the Hand-held Reader Writer has been brought close to the Data Carrier. If the antenna is not in front of the Data Carrier when the activate switch is pressed, a "Data Carrier non-existent error" will result.

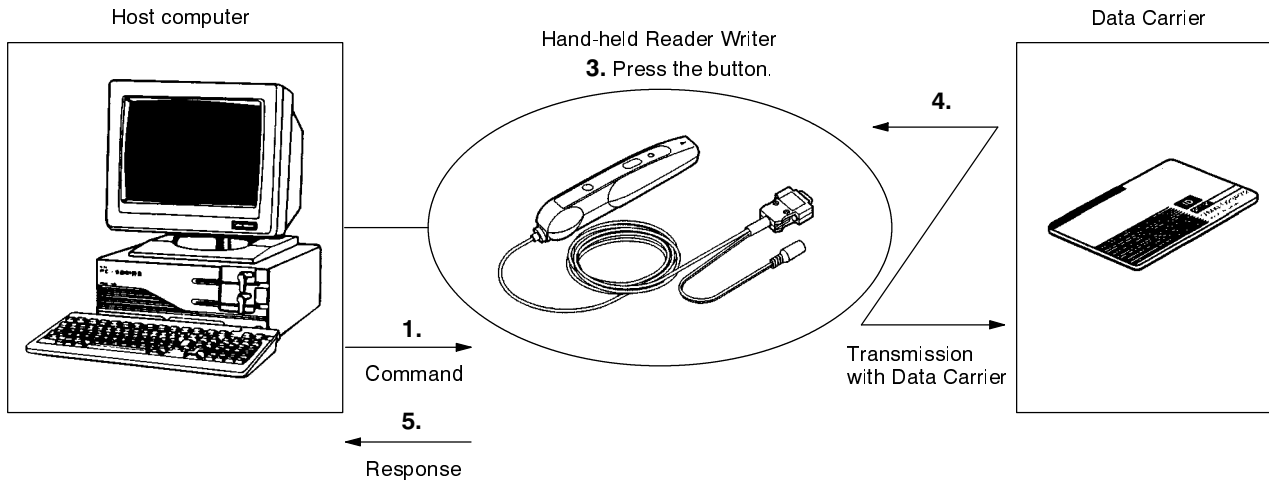

- 1, 2, 3...**
1. A command is sent from the host device to the Hand-held Reader Writer.
 2. Place the antenna of the Hand-held Reader Writer near the Data Carrier.

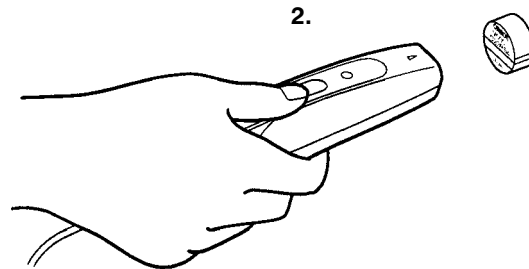

3. Press the Hand-held Reader Writer activate switch.
4. The Hand-held Reader Writer conducts communication with the Data Carrier. The operation indicator (LED) is lit green.
5. A response is given from the Hand-held Reader Writer to the host device. The operation indicator (LED) is not lit.

Auto Commands

Auto commands are able to conduct communications with the Data Carrier when the antenna is placed near the front of the Data Carrier after a command is received from the host device.

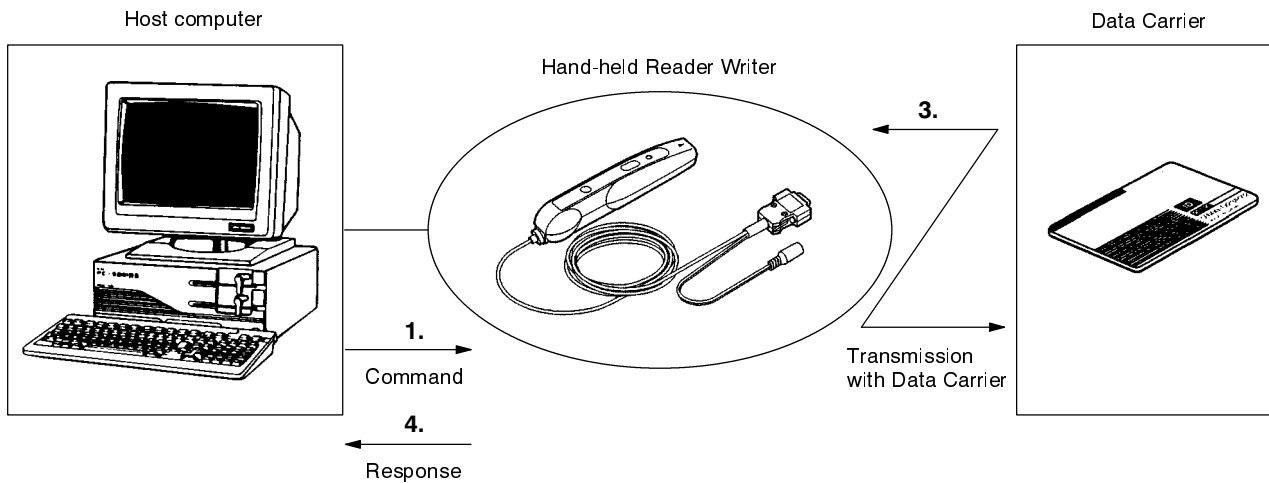

- 1, 2, 3...**
1. A command is sent from the host device to the Hand-held Reader Writer.
 2. The Hand-held Reader Writer enters the communication stand-by state with the Data Carrier, and the operation indicator (LED) is lit green.
 3. Communication with the Data Carrier is performed when the Hand-held Reader Writer antenna is placed near the Data Carrier.
 4. A response is given from the Hand-held Reader Writer to the host device. The operation indicator (LED) is not lit.

Button Auto Commands

Button auto commands issue auto commands after a command is sent from the host device and the activate switch of the Hand-held Reader Writer is pressed.

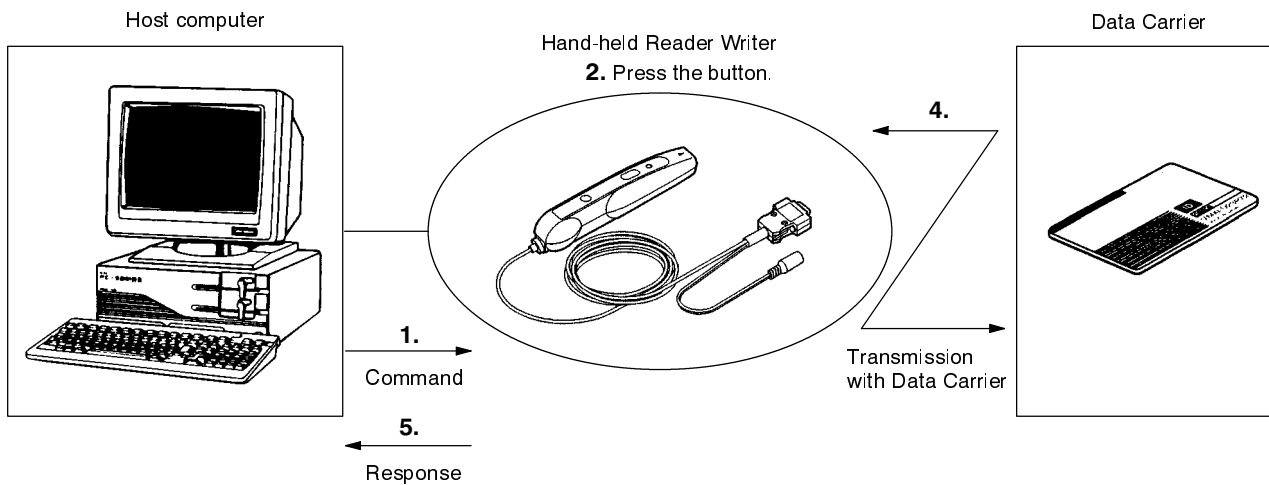

- 1, 2, 3...**
1. A command is sent from the host device to the Hand-held Reader Writer.
 2. Press the Hand-held Reader Writer activate switch.
 3. The Hand-held Reader Writer enters the communication stand-by state with the Data Carrier, and the operation indicator (LED) is lit green.
 4. Communication with the Data Carrier is performed when the Hand-held Reader Writer antenna is placed near the Data Carrier.
 5. A response is given from the Hand-held Reader Writer to the host device. The operation indicator (LED) is not lit.

2-7-2 Multiple Area Control

The Hand-held Reader Writer can read and write across several non-consecutive Data Carrier memory areas (10 areas max.) at one time. To use this feature, the number of control areas is specified using the NUMBER OF CONTROL AREAS command. ASCII and hexadecimal codes can be used simultaneously for the one command control, however reading and writing cannot be performed simultaneously.

Example: Data in the Following 3 Areas are Read

Area (1):	Address:	0010 _H												
	No. of bytes:	05 bytes												
	Code setting:	ASCII												
Area (2):	Address	0030 _H												
	No. of bytes:	02 bytes												
	Code setting:	Hexadecimal												
Area (3):	Address	0035 _H												
	No. of bytes:	03 bytes												
	Code setting:	Hexadecimal												
Command	RDA3001005H003002H003503*													
Response	RD00OMRON1234313233*													
		<table style="margin-left: auto; margin-right: auto;"> <tr> <td style="border: none;">┌───┐</td> <td style="border: none;">┌───┐</td> <td style="border: none;">┌───┐</td> </tr> <tr> <td style="border: none;"> </td> <td style="border: none;"> </td> <td style="border: none;"> </td> </tr> <tr> <td style="border: none;">└───┘</td> <td style="border: none;">└───┘</td> <td style="border: none;">└───┘</td> </tr> <tr> <td style="border: none; text-align: center;">Area (1)</td> <td style="border: none; text-align: center;">Area (2)</td> <td style="border: none; text-align: center;">Area (3)</td> </tr> </table>	┌───┐	┌───┐	┌───┐				└───┘	└───┘	└───┘	Area (1)	Area (2)	Area (3)
┌───┐	┌───┐	┌───┐												
└───┘	└───┘	└───┘												
Area (1)	Area (2)	Area (3)												

Area (1)	0010 _H	4	F	"O"
	0011 _H	4	D	"M"
	0012 _H	5	2	"R"
	0013 _H	4	F	"O"
	0014 _H	4	E	"N"
Area (2)	0030 _H	1	2	
	0031 _H	3	4	
Area (3)	0035 _H	3	1	
	0036 _H	3	2	
	0037 _H	3	3	

Note Refer to 3-1 Command/Response Format for more details on ASCII and hexadecimal codes.

2-7-3 Auto Command Off

Auto commands (auto command or button auto command) are sent from the host device to the Hand-held Reader Writer, and if communication has not commenced with the Data Carrier after one minute has passed from the Data Carrier goes on stand-by (i.e. when green LED lights), the Hand-held Reader Writer will cancel the command automatically and return a Carrier non-existent error response (error code = 72) to the host device. If the Auto Command Off feature is not used, the auto command will not be cancelled even after one minute has passed from when the Data Carrier went on stand-by (i.e., when the green LED lights.)

Auto Command Off is set by using the BASIC FUNCTION SETTING command (FN). (Refer to page 45 to set the function.)

2-7-4 Normal Operation Output

The Normal Operation Output is turned ON when the Hand-held Reader Writer is operating normally. This output can be used to monitor the Hand-held Reader Writer operating status from the host device.

V600-CH1D: Data set ready (DS) output turns ON.

Normal Operation Output is set by the BASIC FUNCTION SETTING command (FN). (Refer to page 45 to set the function.)

2-8 Hand-held Reader Writer Settings

2-8-1 Settings

The following items settings are available when using the Hand-held Reader Writer.

- Serial communications parameters (baud rate, transmission code, error detection, and stop bits.)
- Basic functionality (Auto Command Off and Normal Operation Output)

These settings can make modifications by sending setting commands from the host device. Power must be turned OFF and then back ON or the ABORT command must be used to restart, and to operate the Hand-held Reader Writer with the modified settings.

Serial Communications Parameters Conditions Setting

Set the parameters for serial communication. The command used is "TR."

Item	Contents
Baud rate (bps)	2,400 / 4,800 / 9,600* / 19,200
Transmission code	7-bit ASCII*/8-bit JIS
Error detection	Even parity*/odd parity/none
Stop bit	2*/1

Note Settings marked with an asterisk (*) indicate the default setting.

Basic Function Settings

Set the Auto Command Off and Normal Operation Output. The command used is "FN."

Item	Contents
Auto Command Off	Yes (1 min.) *, none
Normal Operation Output	None*, yes

Note Settings marked with an asterisk (*) indicate the default setting.

2-8-2 Reading the Setting Conditions

Use the SET INFORMATION READ command (UL) to read the Hand-held Reader Writer setting conditions. Information read using the SET INFORMATION READ command is set in the Hand-held Reader Writer back-up memory. Therefore, if the Hand-held Reader Writer is not restarted after setting conditions have been modified using the SETTINGS command, the setting conditions with which the Hand-held Reader Writer is operating will differ.

2-8-3 Initializing Setting Conditions

The Hand-held Reader Writer settings use the SETTINGS command, however if the communication conditions are not known, or the setting conditions are destroyed, communications with the host device may be impossible. If this happens, press the reset switch and the activate switch together at the same time when turning ON the power. All setting conditions will return to the default setting conditions and communications with the host device will be possible.

Reset Procedure

- 1, 2, 3... 1. Turn the power ON while pressing the reset switch.
2. With the reset switch pressed, after 2 seconds have passed, the operation indicator (LED) will flash in green.
3. While the operation indicator (LED) is flashing in green, release the reset switch and press the activate switch.
4. When the activate switch is pressed, the operation indicator (LED) will stop flashing (green) and all setting contents will be initial values.

Note The settings will not be initialized if the activate switch is not pressed within 30 seconds from when the operation indicator (LED) starts to flash in green.

2-9 Data Carrier

The memory access space available to the Hand-held Reader Writer is 0000_H to FFFF_H, or 64 Kbytes. The available access space is determined by the Data Carrier memory capacity. With the Data Carrier memory capacity limited to 256 bytes, the manufacturing date area, write-protect area, and control methods for these differ. The method for allocating system area will differ according to the memory type (SRAM, EEPROM). (Refer to the Read/Write Head and Data Carrier Manuals for more details.)

2-9-1 Memory Map

Data Carrier (Memory capacity \leq 256 bytes)

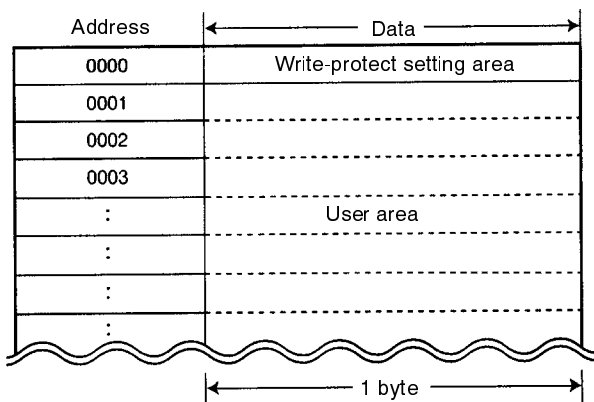

Data Carrier (Memory capacity > 256 bytes)

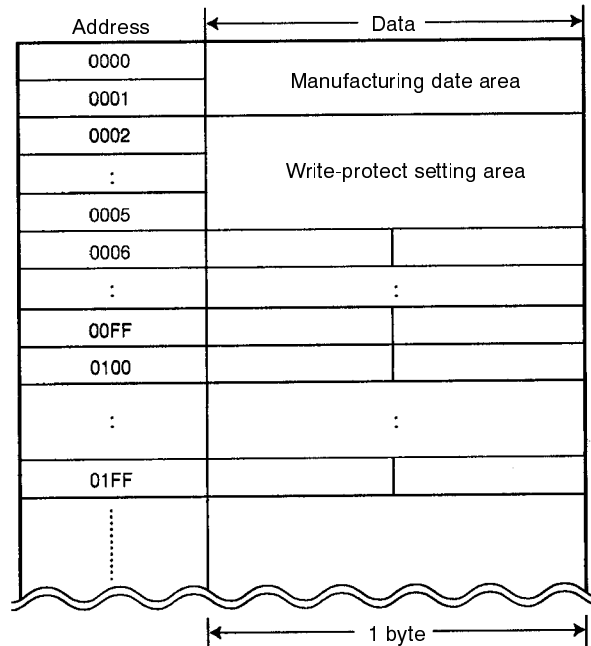

For more information on Data Carrier memory capacity and memory type, refer to *Appendix B Data Carrier Memory Capacity/Memory Type*.

Caution Do not disassemble, deform through excessive pressure, expose to temperatures of 100°C or above, or burn the memory SRAM-type Data Carrier. The device contains lithium batteries which may ignite or explode.

2-9-2 Manufacturing Date Format (Default Setting)

Memory Capacity > 256 Bytes

The first 2 bytes of the memory area, which control the Data Carrier battery life, contain the registered date of manufacture as well. This area can be read, but cannot be written by the user. If a writing operation mistakenly occurs, an error (error code “7D”) will result.

Manufacturing Date Area

Address	Bit							
	7	6	5	4	3	2	1	0
0000 _H	Second digit of month				First digit of month			
0001 _H	Second digit of year				First digit of year			

- Note**
1. The year of manufacturing is represented by the last two digits of the year (for example, “96” for 1996).
 2. The month of manufacturing is represented by two digits (for example, “03” for March and “10” for October).

Example: Manufactured in September 1992

Address	Bit							
	7	6	5	4	3	2	1	0
0000 _H	0	0	0	0	1	0	0	1
	0				9			
0001 _H	1	0	0	0	1	0	0	1
	9				2			

Memory Capacity ≤ 256 Bytes

There is no manufacturing date area. The start address is a write-protected area.

2-9-3 Write-Protect Function

The write-protect function prevents important data stored in the Data Carrier such as the product type and model from being overwritten by other data. Write-protect can be set in the following way.

Memory Capacity ≤ 256 Bytes

Write-Protect Setting Procedure

If a write-protect end address is specified in address 0000_H in the Data Carrier, the area between address 0001_H and the write-protect end address will be write-protected. Whether or not the write-protect function is enabled is specified by the most significant bit of address 0000_H.

Address	Bit							
	7	6	5	4	3	2	1	0
0000 _H	YES/ NO	End address						

Write-protect Execution Bit (Most significant bit of address 0000_H)

1: Write-protected

0: Not write-protected

End Address Setting Range: 00_H, 01_H to 7F_H

Therefore, addresses 0080_H to 00FF_H cannot be specified as an end address. If 00_H is specified as an end address, addresses 0001_H to 00FF_H will be write-protected.

Write-protect Setting Examples (254-byte Memory Data Carrier)

The area between addresses 0000_H and 0012_H is write-protected.

Address	Bit							
	7	6	5	4	3	2	1	0
0000 _H	1	0	0	1	0	0	1	0
9				2				

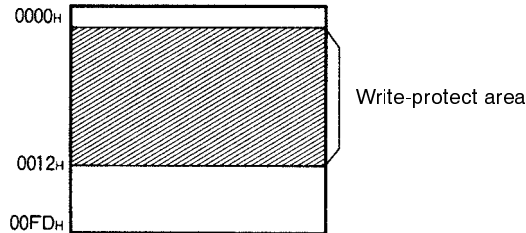

If the end address is 00_H, the entire area except address 0000_H is write-protected.

Address	Bit							
	7	6	5	4	3	2	1	0
0000 _H	1	0	0	0	0	0	0	0
8				0				

When the end address is 00_H

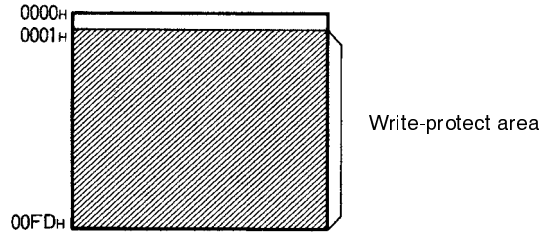

Cancelling Write Protection To cancel write-protection, set the most significant bit of address 0000_H to 0. The write-protect area specified in address 0000_H will become invalid. Accordingly, the write-protect area will be cancelled.

- Note**
1. Address 0000_H cannot be write-protected.
 2. The write-protect start address is fixed at 0000_H. Always specify a write-protect area starting from address 0000_H.

Memory Capacity > 256 Bytes

Write-protect Setting Procedure

Addresses 0002_H to 0005_H (four bytes) in the Data Carrier are used to set a write-protect area. Whether or not the write protect function is enabled is specified by the most significant bit of address 0002_H.

To Enable Write Protect

Address	Bit							
	7	6	5	4	3	2	1	0
0002 _H	YES/NO	Upper two digits of start address						
0003 _H	Lower two digits of start address							
0004 _H	Upper two digits of end address							
0005 _H	Lower two digits of end address							

- Write-protect Setting Bit (most significant bit of address 0002_H)
 - 1: Write protected
 - 0: Not write protected
- Write-protect Setting Area
 - Start address: 0006_H to FFFF_H
 - End address: 0006_H to FFFF_H

Note To Protect Addresses 0006_H Through 07FF_H:

Address	Bit							
	Upper digits				Lower digits			
0002	1	0	0	0	0	0	0	0
	8				0			
0003	0	0	0	0	0	1	1	0
	0				6			
0004	0	0	0	0	0	1	1	1
	0				7			
0005	1	1	1	1	1	1	1	1
	F				F			

To Not Protect Addresses:

Address	Bit							
	Upper digits				Lower digits			
0002	0	0	0	0	0	0	0	0
	0				0			
0003	0	0	0	0	0	0	1	0
	0				6			
0004	0	0	0	0	0	1	1	1
	0				0			
0005	0	0	0	0	0	0	0	0
	0				0			

Write-protect Setting Examples (2-Kbyte Memory Data Carrier)

When Addresses 0015_H to 0120_H are Write-protected

Start address < End address

Address	Bit							
	7	6	5	4	3	2	1	0
0002 _H	1	0	0	0	0	0	0	0
	8				0			
0003 _H	0	0	0	1	0	1	0	1
	0				5			
0004 _H	0	0	0	0	0	0	0	1
	0				1			
0005 _H	0	0	1	0	0	0	0	0
	2				0			

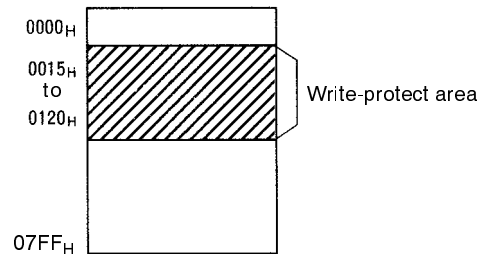

When Only One Byte is Write-protected

Start address = End address

The same address is specified for the start and end addresses.



When the End Address is Greater than the Last Address in the Data Carrier

End address > 07FF_H

Since the memory area in the Data Carrier is from 0000_H to 07FF_H, the area between the start address and 07FF_H is write-protected.

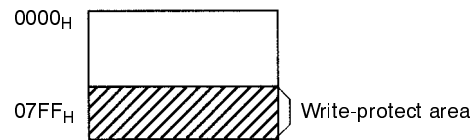

When the Start Address is Greater than the End Address

Start address > End address

The area between 0006_H and the end address and the area between the start address and 07FF_H are write-protected.

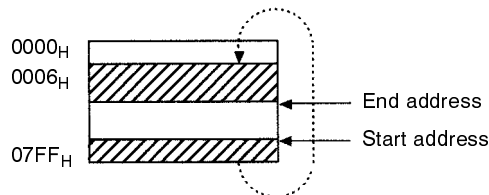

Cancelling Write Protection

To cancel write protection, set the most significant bit of address 0002_H to 0. The write-protection specified in address 0002_H to 0005_H will become invalid. Accordingly, the write protection will be cancelled.

2-9-4 Detecting Function of Data Carrier Life

Methods for detecting the life of the Data Carrier differ according to the memory type (SRAM or EEPROM). For SRAM, a battery life check is performed, and for EEPROM, the number of overwrites is monitored.

SRAM (Built-in Battery) Data Carriers

Checking If the Battery is Low

- 1, 2, 3...
1. A battery-low check for the Data Carrier can only be performed when special access is made. The battery-low check is made by running a fixed current through the internal circuit of the Data Carrier. If the battery-low check is made during access, battery power is also consumed. It is recommended that this be included as a routine check, once a day, when creating system programs.
 2. The access method for conducting a battery-low check can only be performed when the two bytes of data from 0000_H to 0001_H are read.

Execute Battery-low Check Commands:

- a. READ command RD H/A1 0000 02*_↓
- b. AUTO READ command AR H/A1 0000 02*_↓
- c. BUTTON READ command BR H/A1 0000 02*_↓
- d. BUTTON AUTO READ command .. UR H/A1 0000 02*_↓

3. Response when Battery is Low:

When the battery is low, 7B is given in the end code section within the response format.

Normal

RD 0 0 0 9 9 5 *

AR 0 0 0 9 9 5 *

Normal end code Read data manufactured Sept. '95

Battery is Low

RD 7 B 0 9 9 2 *

AR 7 B 0 9 9 2 *

Battery-low error code Read data manufactured Sept. '92

Data Carrier Life after Low Battery Signal Occurs

After a battery-low signal is sent, the Data Carrier may be used for approximately 1 month in the normal operating state, however, the Data Carrier should be replaced as quickly as possible.

Note The Data Carrier houses a thionyl chloride lithium battery. A characteristic of the thionyl chloride lithium battery is that the internal resistance of the battery increases when the battery is left sitting without being used for several months. If this occurs and a Data Carrier battery-low check is performed, a low battery response may be given despite the fact that battery life still remains. This is because the resistance within the battery has increased, not because the battery life ended. If a Data Carrier is used which has been left for several months after purchase without being used, use the read operation for approx. 10 minutes to activate the battery. (Current will flow in the battery and resistance in the battery will return to normal as a result of activating the battery. There will be no effect on the life of the battery.)

EEPROM (Batteryless) Data Carriers

The OVERWRITE COUNT CONTROL command (MDS) can determine whether the EEPROM overwrite count has been exceeded. Overwrite count initial values are written to the user-specified overwrite count control area. When the

OVERWRITE COUNT CONTROL command is executed, the specified data is decremented from the overwrite count control area, and whether or not the data has exceeded the limits will be determined.

Command Format

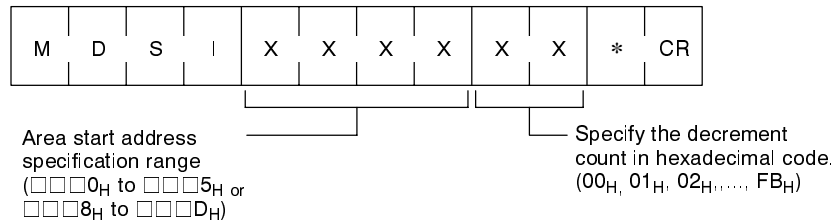

Response Format

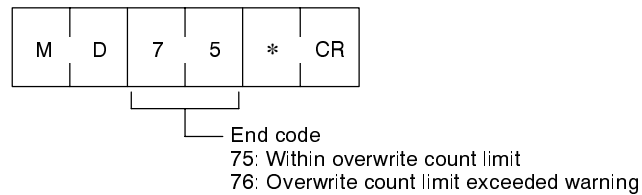

The overwrite control area consists of 3 bytes from the start address. The decrement value from the overwrite count is written in this area, and if this value is 0 an end code 76 will be given as a warning. The remaining overwrite count will be written into the control area in hexadecimal. This can be read with the READ command.

If the control area data is already 0, the control area value will not be refreshed, and only a warning will be given in response. When the decrement count is set as "00_H," the count will not be updated, and only a overwrite count check will be performed.

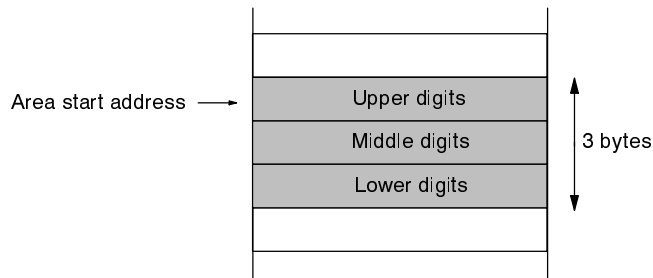

Note Set the start address at □□□0_H to □□□5_H or □□□8_H to □□□D_H. If the start address is set at □□□6_H to □□□7_H or □□□E_H to □□□F_H an address error (code: 7A (hexadecimal)) will be returned as an end code.

Using the OVERWRITE COUNT Command

- 1, 2, 3... 1. The overwrite count initial value of 100,000 times is written in the control area.
"WTH10010"

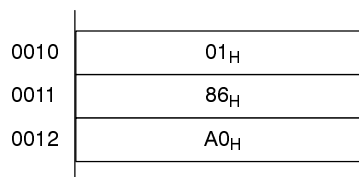

2. Enter the overwrite count of "4."
"MDS1001004"

0010	01 _H
0011	86 _H
0012	9C _H

3. Enter the next overwrite count of 5.
"MDS1001005"
A total of 9 times.

0010	01 _H
0011	86 _H
0012	97 _H

4. The accumulated count is 100,000 times.
When "MDS1001000" is executed it will be "MD76" (overwrite count exceeded.)

0010	00 _H
0011	00 _H
0012	00 _H

2-9-5 Memory Check Function in Data Carrier

A memory check can be made using the DATA CHECK command (MD). A CRC (Cyclic Redundancy Check) code calculation, overwrite, and comparison are made, using the check block units specified by the user. The CRC code is calculated from the polynomial expression created; $x^{16} + x^{12} + x^5 + 1$.

Command Format

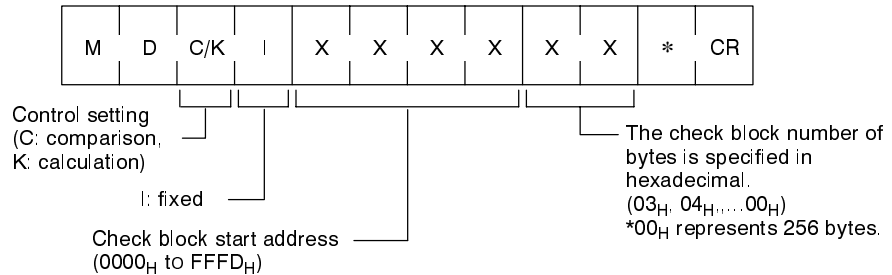

Response Format

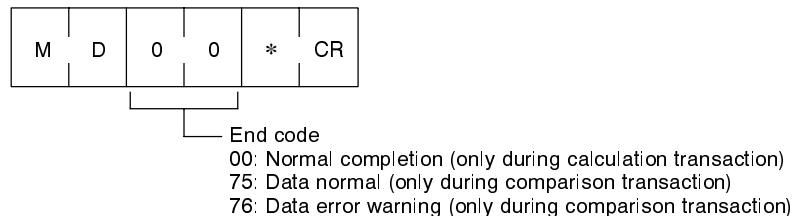

The area in the check block, specified with the start address and number of bytes and excluding the last two bytes of the block, is the area for calculation. The last two bytes are the check code area.

When check code write is specified (transaction code: K), the CRC of the calculation area data is calculated and written to the check code area. When data comparison is specified (transaction code: C), the CRC of the calculation area data is calculated and a comparison made with the check code area data. If these are consistent, an end code (75) will be returned, and if they are inconsistent an error code (76) will be returned.

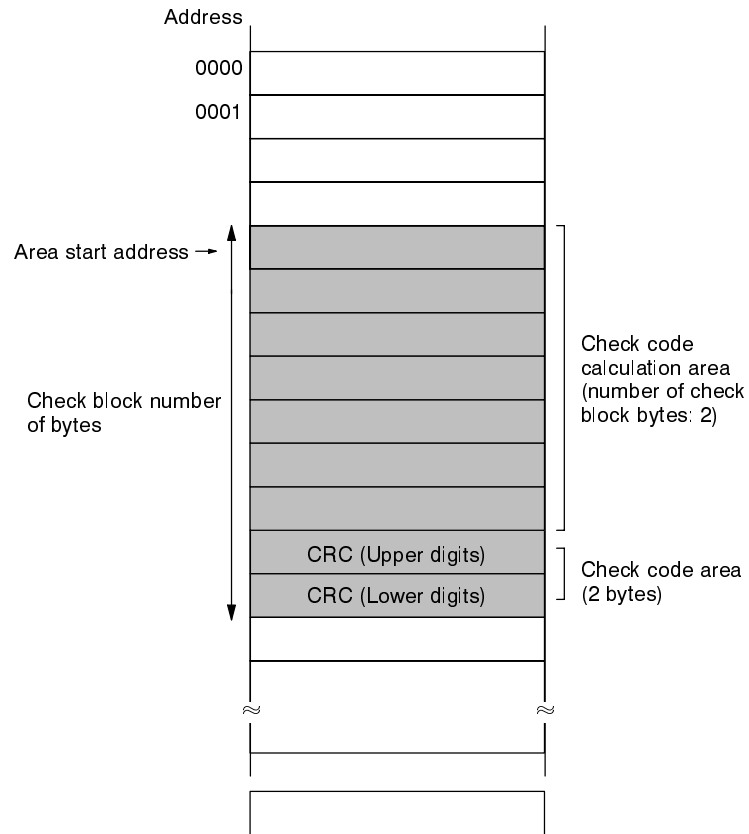

Example of Memory Check Command Use

Performing a data check from address 0010_H to 0012_H.

- 1, 2, 3... 1. If the following data is stored.

0010	12 _H
0011	34 _H
0012	56 _H
0013	
0014	

2. Execute "MDK1001005" (calculation transaction).
The CRC code (5CD6) calculated from "123456" will be written to addresses 0013 and 0014.

0010	12 _H
0011	34 _H
0012	56 _H
0013	5C _H
0014	D6 _H

- 3. Execute "MDC1001005" (comparison transaction).
If the data is correct, "MD75" (data correct) response will be returned.

0010	12 _H
0011	34 _H
0012	56 _H
0013	5C _H
0014	D6 _H

- 4. If data differs, "MD76" (data error) will be returned.

0010	12 _H	← Data error
0011	34 _H	
0012	56 _H	
0013	5C _H	
0014	D6 _H	

SECTION 3

Host Communications

This section describes the command and response formats for communications between the host device and the Hand-held Reader Writer.

3-1	Command/Response Format	28
3-1-1	Specifying Data Code	28
3-1-2	Range of Address and Number of Bytes	29
3-2	Command Format	32
3-2-1	Command/Response List	32
3-2-2	READ (RD)	33
3-2-3	WRITE (WT)	34
3-2-4	AUTO READ (AR)	35
3-2-5	AUTO WRITE (AW)	36
3-2-6	BUTTON READ (BR)	37
3-2-7	BUTTON WRITE (BW)	38
3-2-8	BUTTON AUTO READ (UR)	39
3-2-9	BUTTON AUTO WRITE (UW)	40
3-2-10	FILL (FL)	41
3-2-11	COMMAND PROCESSING TERMINATE (AA)	43
3-2-12	DATA CHECK (MDC/K)	43
3-2-13	Rewrite Count CONTROL (MDS)	44
3-2-14	TEST (TS)	44
3-2-15	ABORT (XZ)	44
3-2-16	COMMUNICATIONS CONDITIONS SETTING (TR)	45
3-2-17	BASIC FUNCTIONS SETTING (FN)	45
3-2-18	SET INFORMATION READ (UL)	46
3-2-19	Command Undefined Response (IC)	46
3-2-20	Error Response	46
3-3	End Code List	48
3-4	Communications Time	48

3-1 Command/Response Format

The format of commands sent from the host computer to the Hand-held Reader Writer and responses returned from the Hand-held Reader Writer to the host computer are shown below. Both the command and response consist of a single frame of up to 331 characters (including the terminator.)

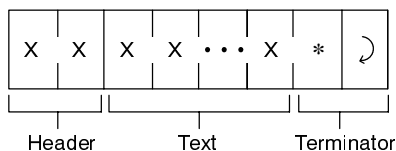

Type	Description	
Header	Command	Two-character symbol indicating operation.
	Response	Symbol same as header of executed command
Text	Command	Contents of processing: - ASCII/Hexadecimal code specification - Processing area number specification - Processing start address - Number of bytes to be processed (for READ command), write data (for WRITE command)
	Response	Result of processing - End code - Read data (for READ command)
Terminator	Indicates end of command or response. Note: * indicates "2A"H of ASCII code, and CR indicates "0D"H.	

3-1-1 Specifying Data Code

Whether the read or write data is treated as an ASCII (or JIS 8) code or hexadecimal code is specified in a command.

ASCII (JIS 8 Code)

One character of ASCII or JIS 8 code data occupies 1 byte (1 address) of the Data Carrier memory.

Example of Specifying ASCII Code

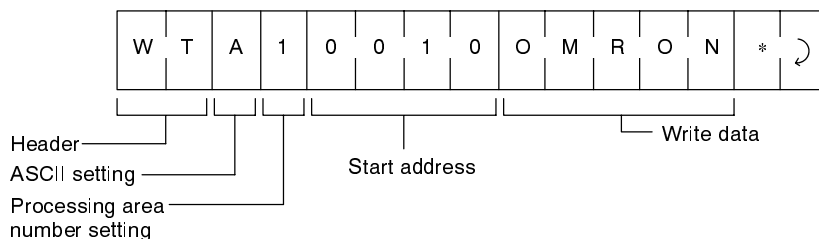

Data Carrier Memory Address

Address			
0010	4	F	"O"
0011	4	D	"M"
0012	5	2	"R"
0013	4	F	"O"
0014	4	E	"N"

Hexadecimal Code

One character is treated as a hexadecimal number. Therefore, only numerals 0 through 9 and A to F can be accepted.

Two characters of data occupy 1 byte (1 address) of the Data Carrier memory. Therefore, specify data in 2-character units (in even numbers) when using a WRITE command. If an odd number of characters is specified by mistake, an error will occur.

Example of Specifying Hexadecimal Code

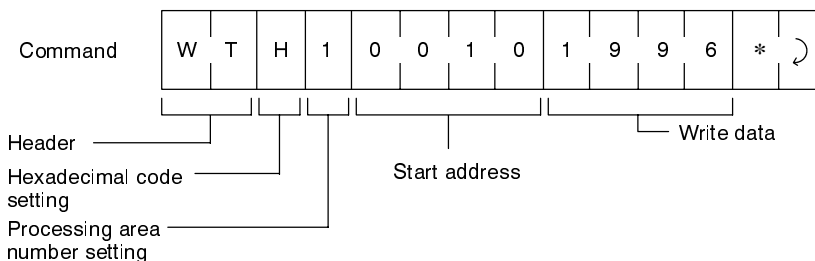

Data Carrier Memory Address

Address		
0020	1	9
0021	9	6
	← 1 byte	

3-1-2 Range of Address and Number of Bytes

READ Command

One Processing Area

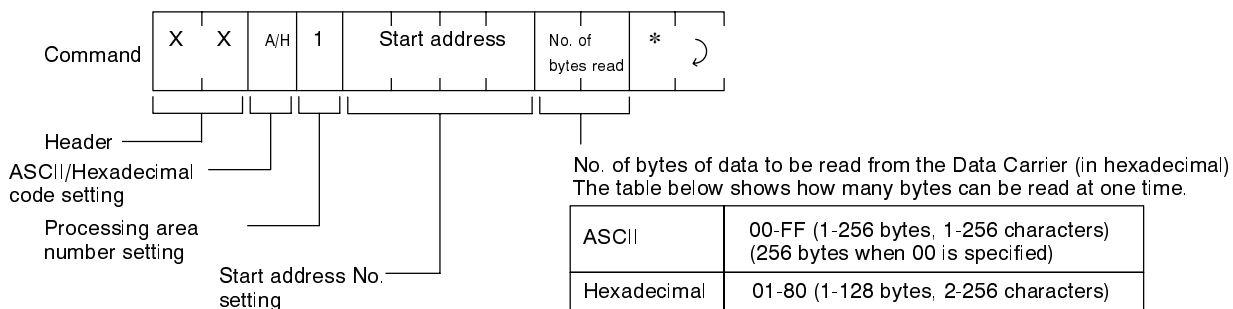

Two or More Processing Areas

The number of processing areas can be set to a maximum of 10 areas, and both ASCII or hexadecimal code can be used within one command.

When multiple area controls are used, the following precautionary items indicate problems with command descriptions.

- Specify the area in order from the smallest address.
- Areas cannot be specified in duplicate.

A command entry error will occur if the above precautions are not observed.

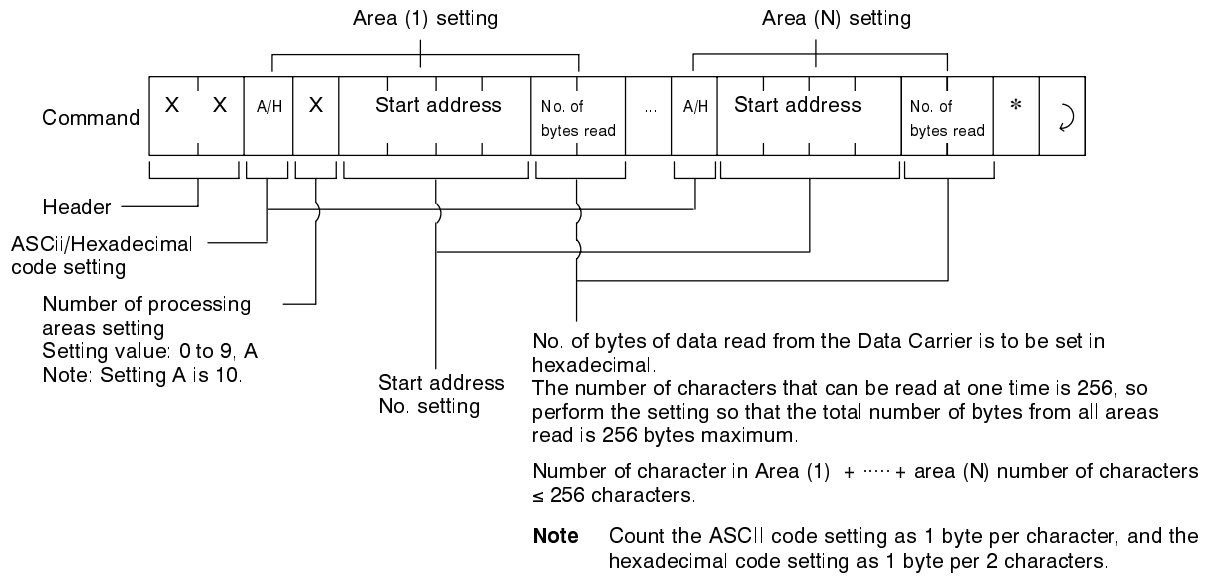

WRITE Command

One Processing Area

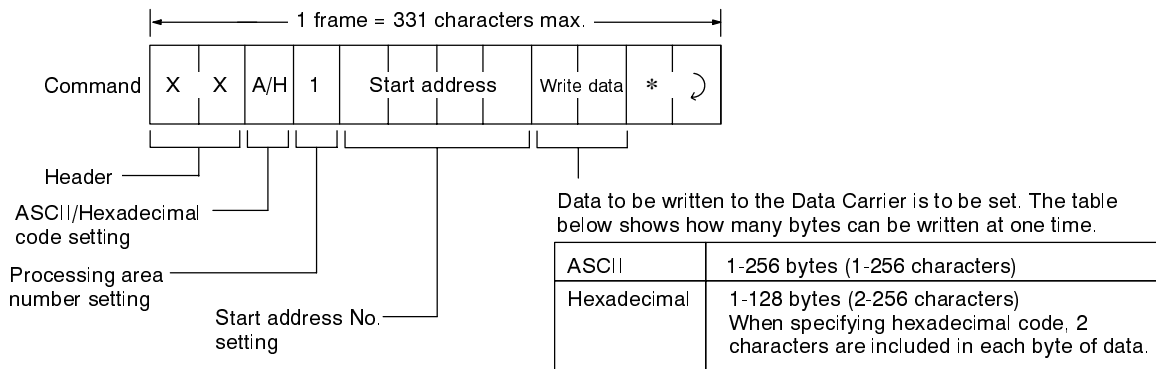

3-2 Command Format

3-2-1 Command/Response List

No.	Command	Header	Description	Page
1	READ	RD	Reads or writes data to or from the Data Carrier. If the Data Carrier is not in the communications area, an error response is returned.	33
2	WRITE	WT		34
3	AUTO READ	AR	Reads or writes data to or from Data Carrier after the Data Carrier reaches the communications area. Responds upon completion of command processing.	35
4	AUTO WRITE	AW		36
5	BUTTON READ	BR	Reads or writes data after the activate switch is pressed.	37
6	BUTTON WRITE	BW	If the Data Carrier is not in communications area, an error response is returned.	38
7	BUTTON AUTO READ	UR	After the activate switch is pressed, the Hand-held Reader Writer waits for the Data Carrier to approach and then reads or writes data. A response is given when communications with the Data Carrier are complete.	39
8	BUTTON AUTO WRITE	UW		40
9	FILL	FL	The specified memory area of the Data Carrier is filled with setting data.	41
10	COMMAND PROCESSING TERMINATE	AA	Terminates processing of auto commands, button commands or button auto commands.	43
11	DATA CONTROL	MD	Data Carrier memory data check is performed. Performs Data Carrier memory (EEPROM type) overwrite count control.	43, 44
12	TEST	TS	Returns as a response a test message sent from host computer.	44
13	ABORT (Reset)	XZ	Restores Hand-held Reader Writer to previous state upon power application. No response will be returned. Do not execute this command while the Hand-held Reader Writer and Data Carrier are communicating.	44
14	COMMUNICATIONS CONDITIONS SETTING	TR	Sets the communications conditions with the host computer. Modified settings become effective after using the ABORT command or by turning the power OFF then ON again.	45
15	BASIC FUNCTIONS SETTING	FN	Sets functions such as Auto Command Off. Modified settings become effective after using the ABORT command or turning the power OFF then ON again.	45
16	SET DATA READ	UL	Reads the communications conditions and basic functions settings.	46
17	Command undefined response	IC	Response returned by Hand-held Reader Writer when the Hand-held Reader Writer receives an undefined command from host computer.	46

Note Only upper-case letters can be used in commands. Lower-case letters will result in an error.

3-2-2 READ (RD)

Reads data from the Data Carrier. If the Data Carrier is not in the communications area, an error response (end code: 72 = Data Carrier missing) will be returned.

One Processing Area

Command Format

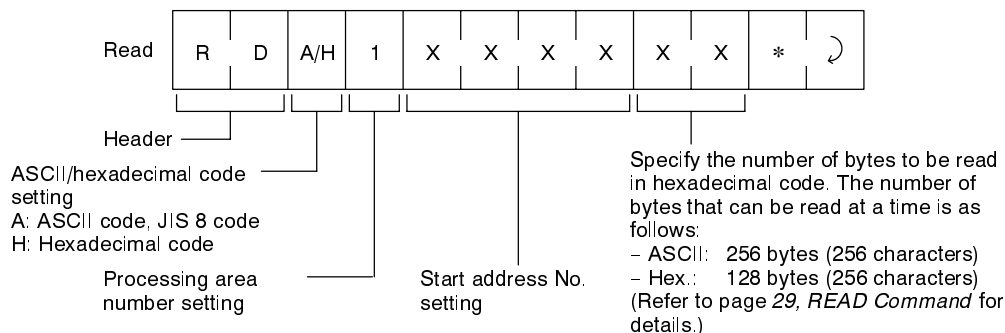

Response Format

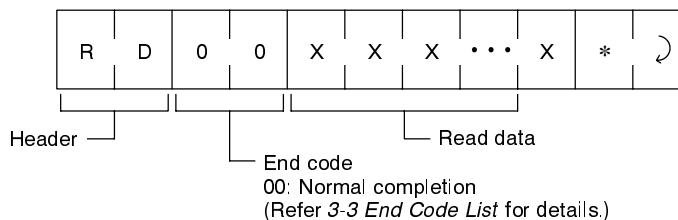

Two Processing Areas

Command Format

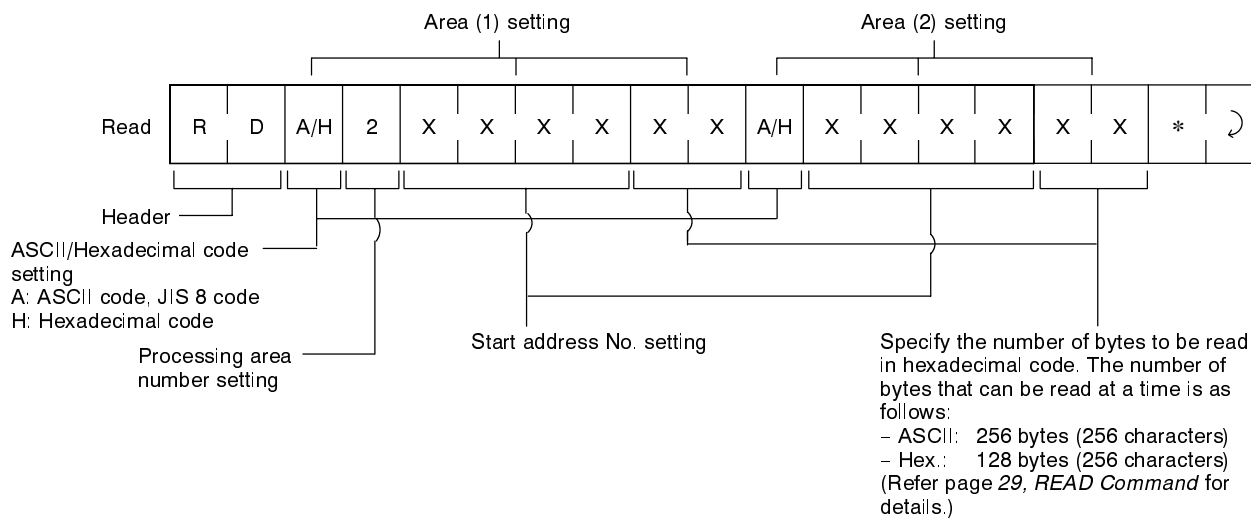

Response Format

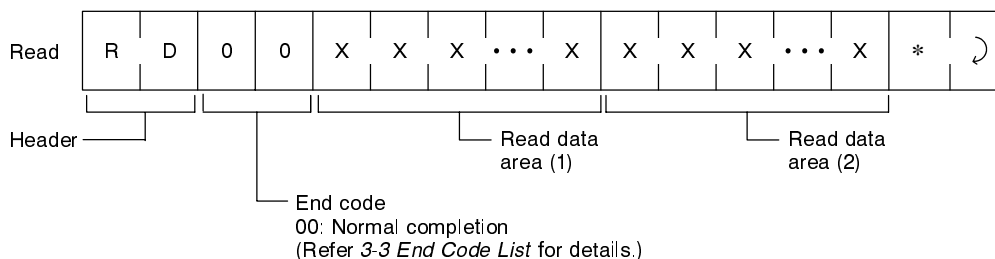

3-2-3 WRITE (WT)

Writes data to the Data Carrier. If the Data Carrier is not in the communications area, an error response (end code: 72 = Data Carrier missing) will be returned.

One Processing Area

Command Format

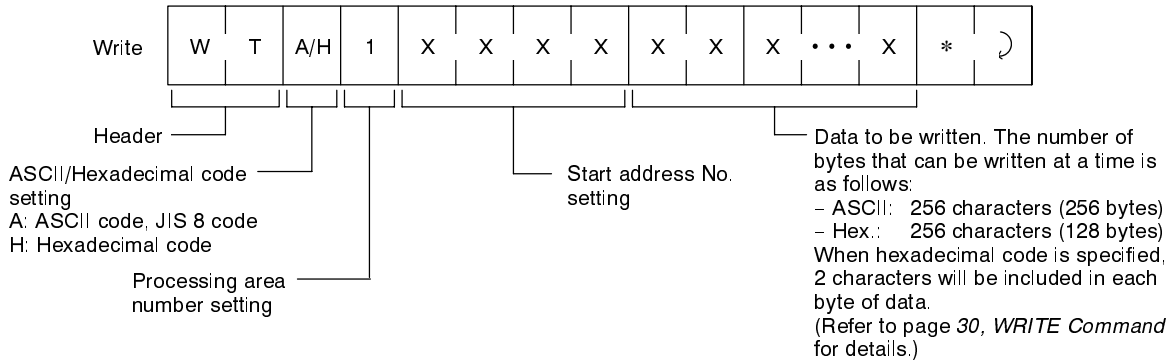

Response Format

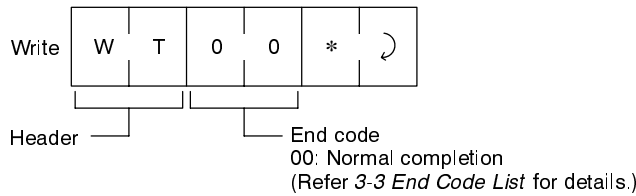

Two Processing Areas

Command Format

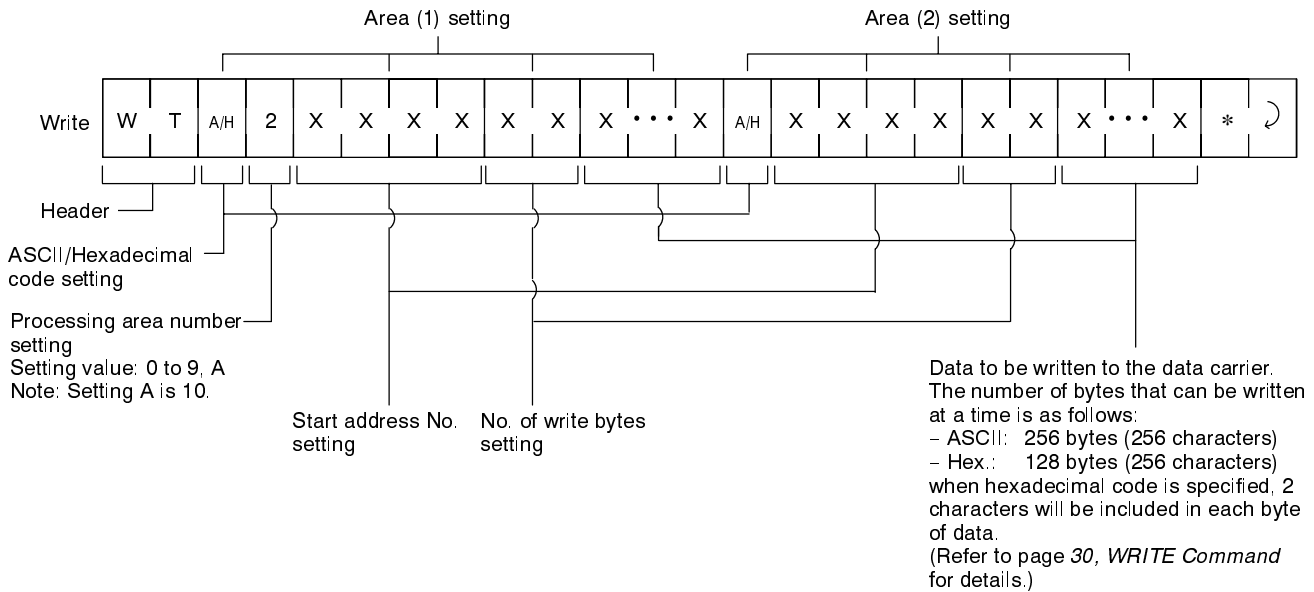

Response Format

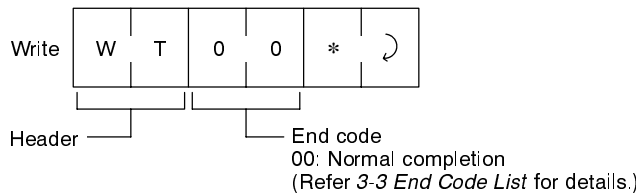

3-2-4 AUTO READ (AR)

Reads data when the Data Carrier has approached. The Hand-held Reader Writer responds when the communication between the Hand-held Reader Writer and Data Carrier has ended.

One Processing Area

Command Format

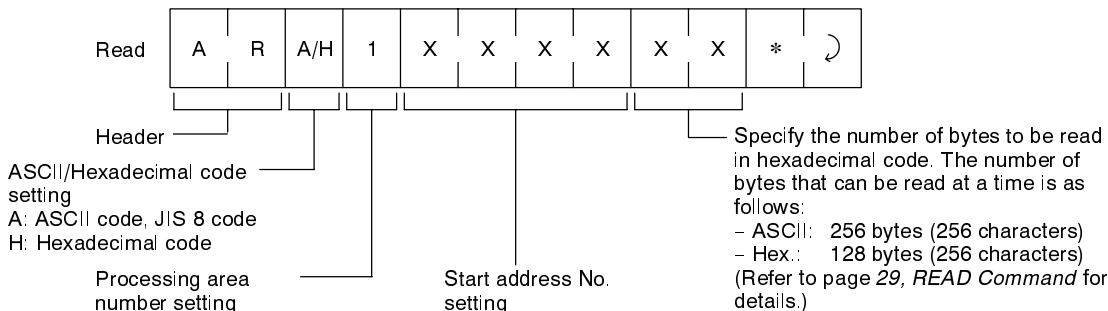

Response Format

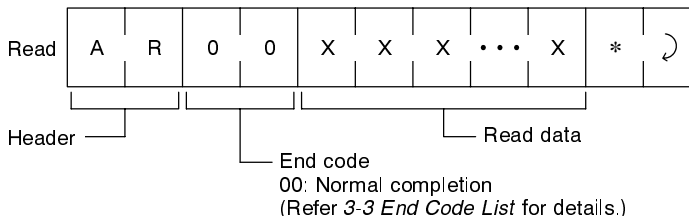

Two Processing Areas

Command Format

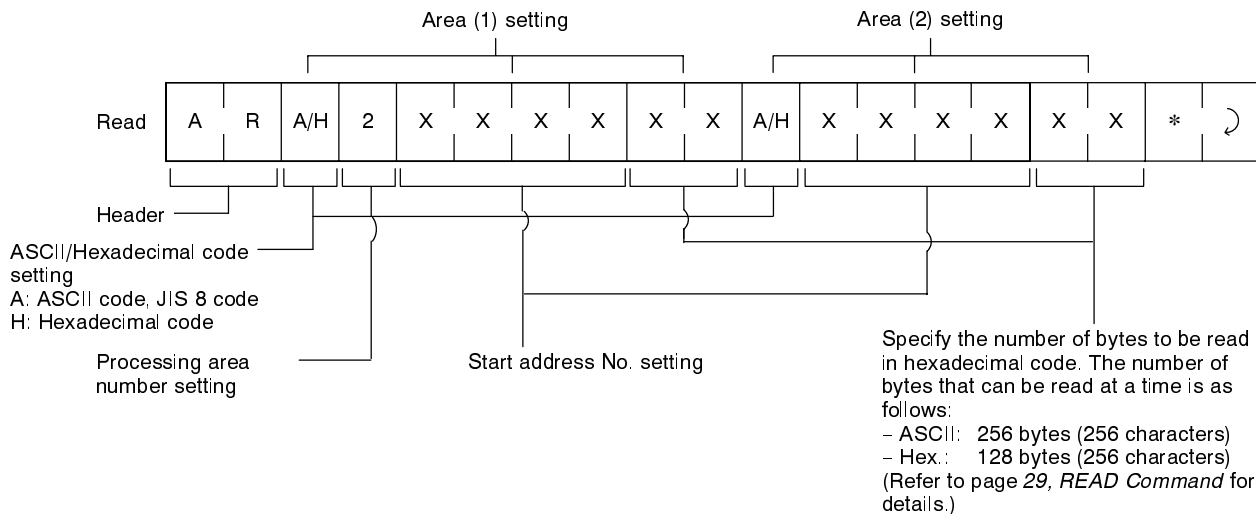

Response Format

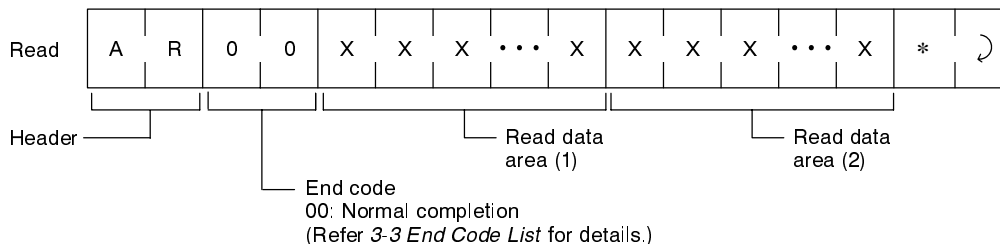

3-2-5 AUTO WRITE (AW)

Writes data when the Data Carrier has approached. The Hand-held Reader Writer responds when the lower communication (between the Hand-held Reader Writer and Data Carrier) has ended.

One Processing Area

Command Format

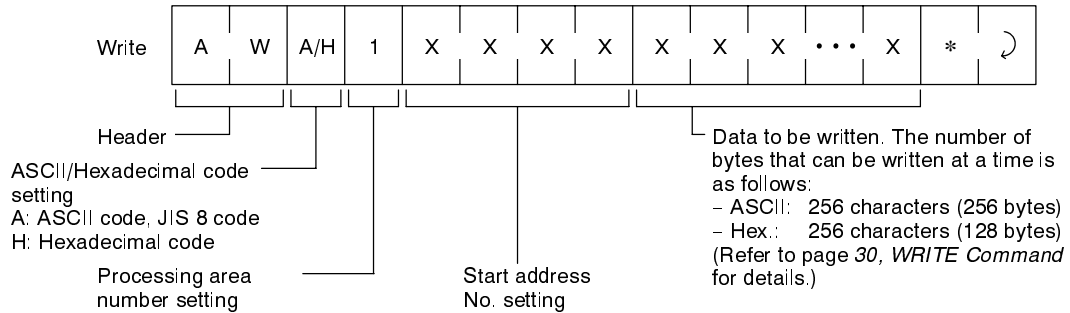

Response Format

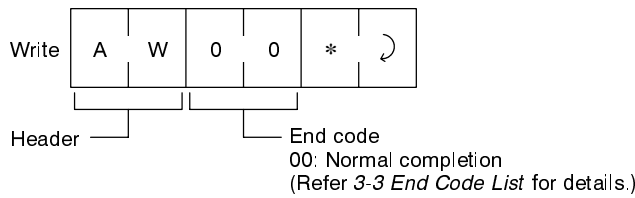

Two Processing Areas

Command Format

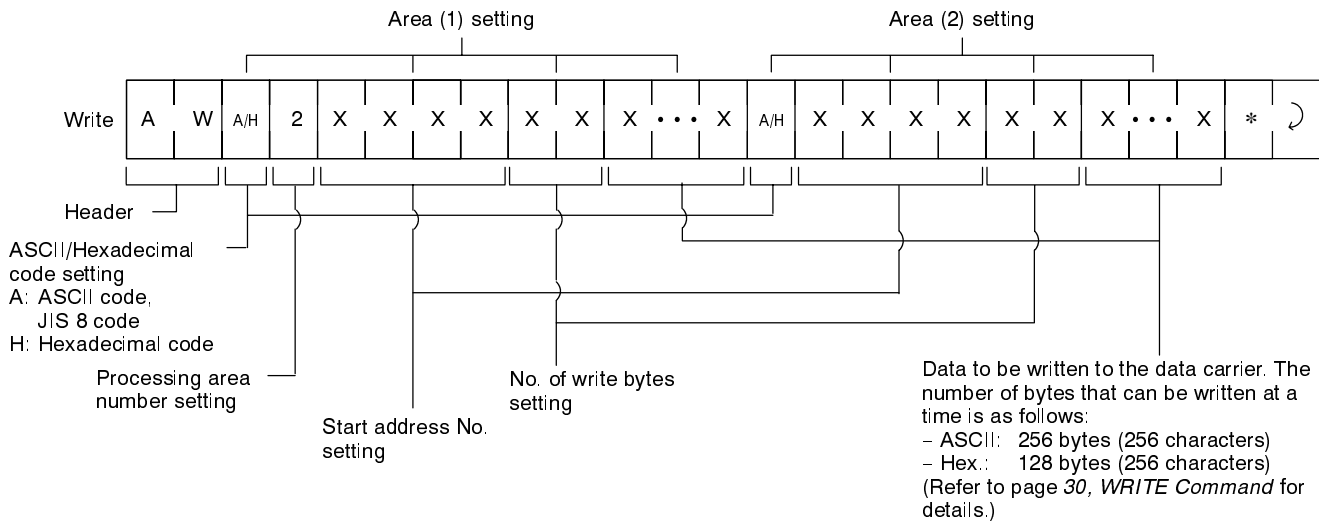

Response Format

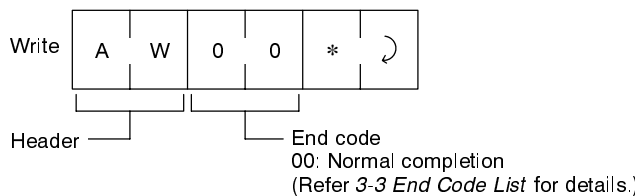

3-2-6 BUTTON READ (BR)

After the Hand-held Reader Writer has received the BUTTON READ command, data is read from the Data Carrier by pressing the activate switch. When the activate switch is pressed and the Data Carrier is not in communications range an error response (end code: 72 = Data Carrier non-existent) will be returned.

One Processing Area

Command Format

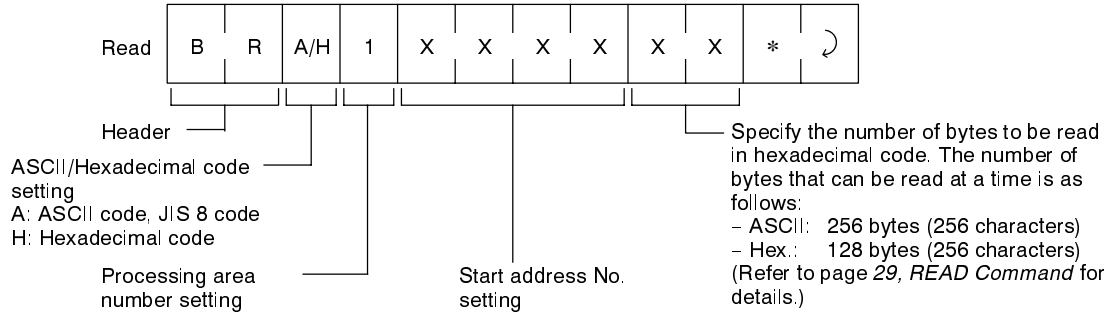

Response Format

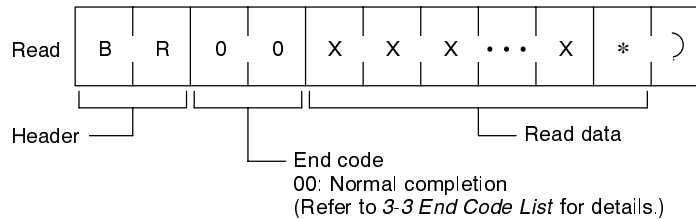

Two Processing Areas

Command Format

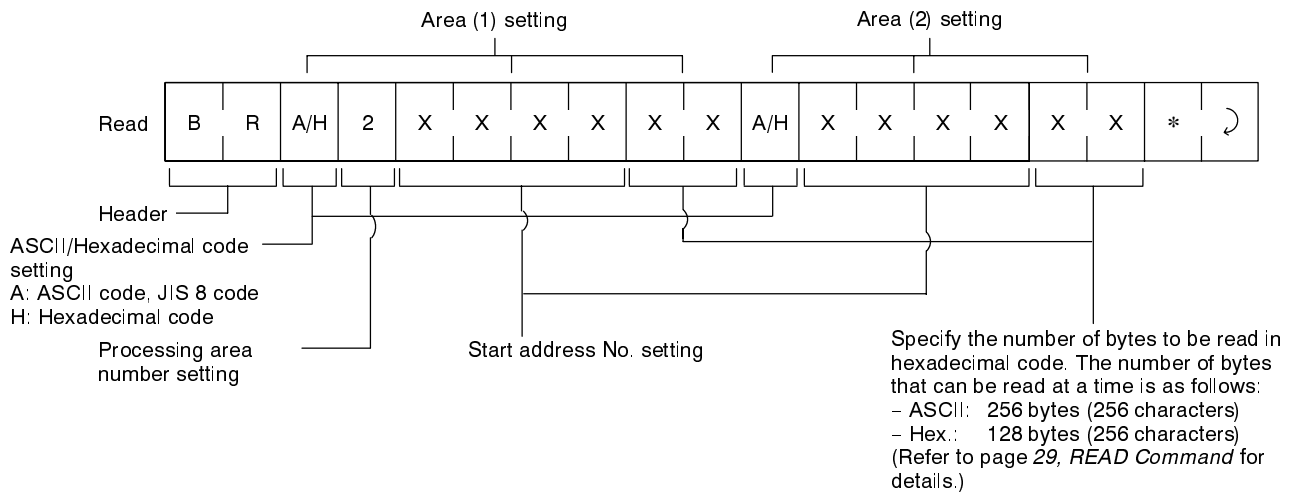

Response Format

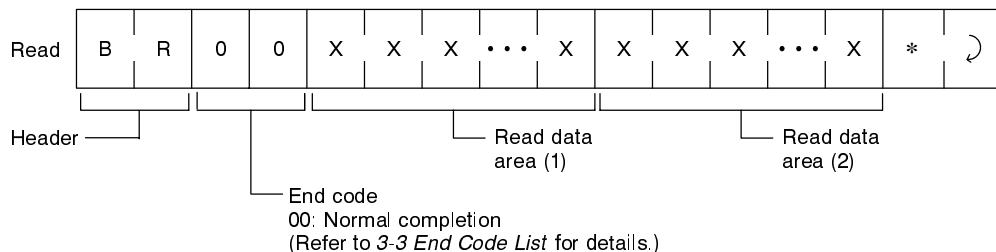

3-2-7 BUTTON WRITE (BW)

After the Hand-held Reader Writer has received the BUTTON WRITE command, data is written onto the Data Carrier by pressing the activate switch. When the activate switch is pressed and the Data Carrier is not in communications range, an error response (end code: 72 = Data Carrier absent) will be returned.

One Processing Area

Command Format

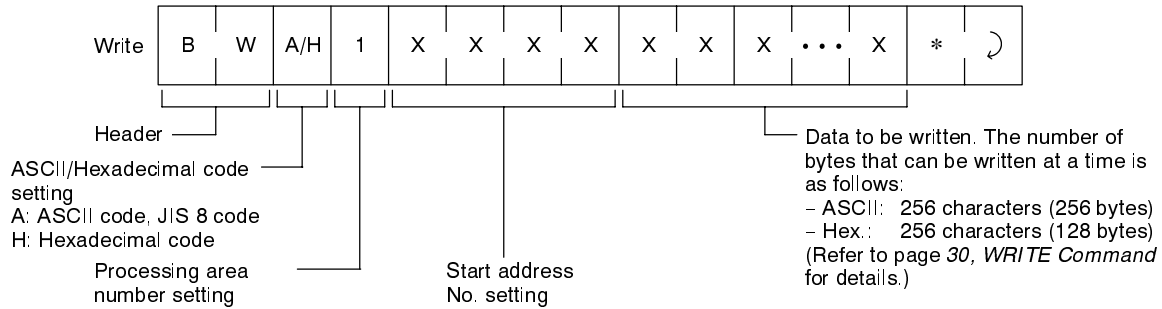

Response Format

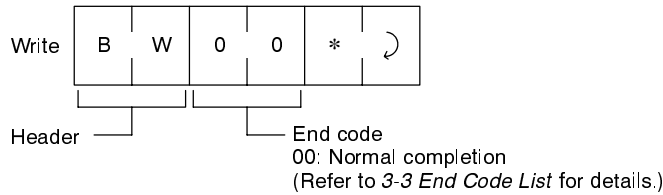

Two Processing Areas

Command Format

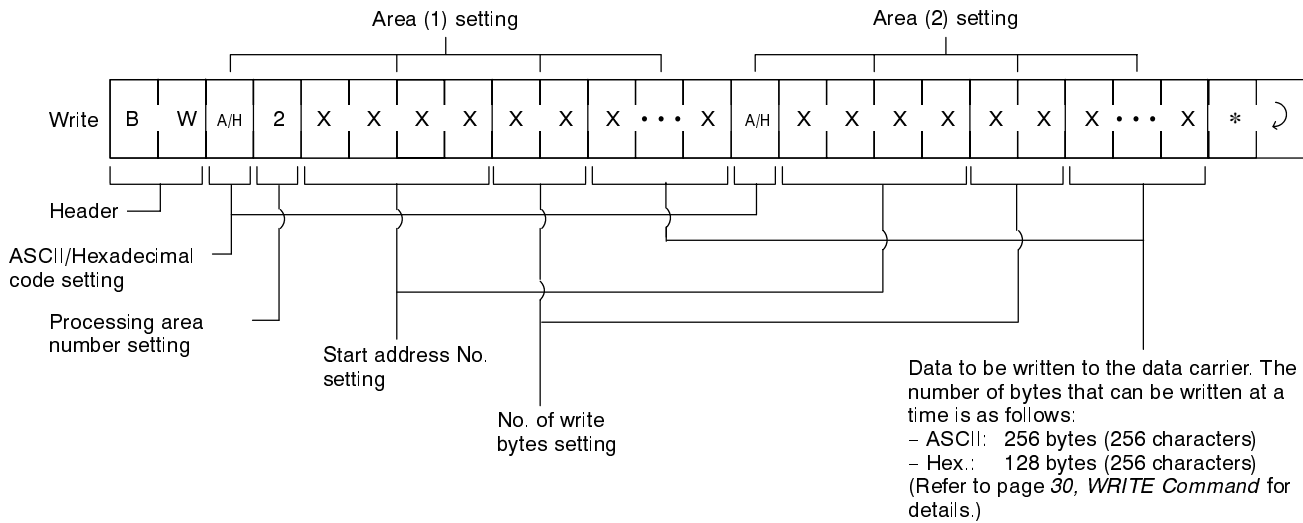

Response Format

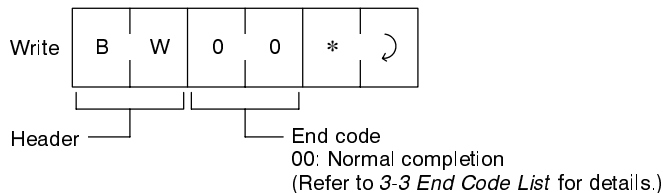

3-2-8 BUTTON AUTO READ (UR)

After the Hand-held Reader Writer has received the BUTTON AUTO READ command, data will be read from the Data Carrier after the activate switch is pressed and the Hand-held Reader Writer is held close to the Data Carrier. The Hand-held Reader Writer will give a response once communications with the Data Carrier are complete.

One Processing Area

Command Format

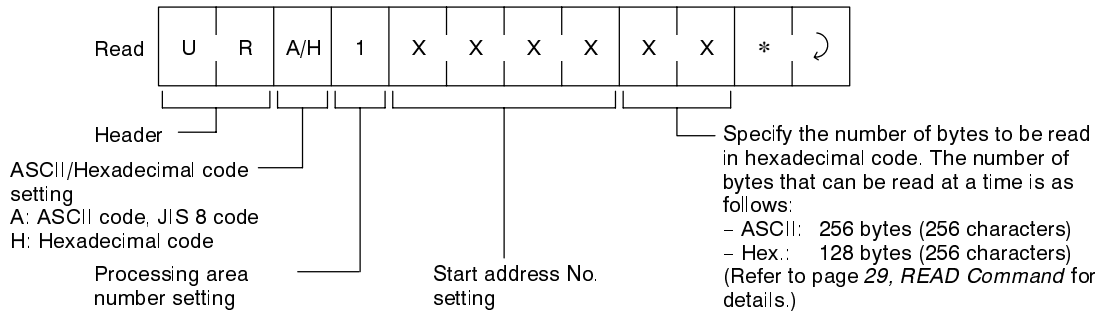

Response Format

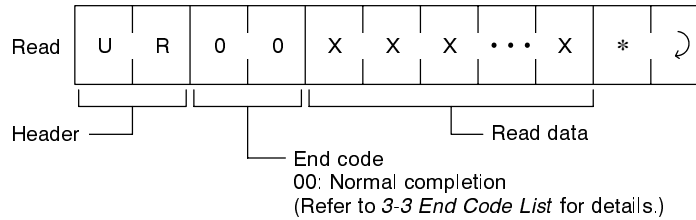

Two Processing Areas

Command Format

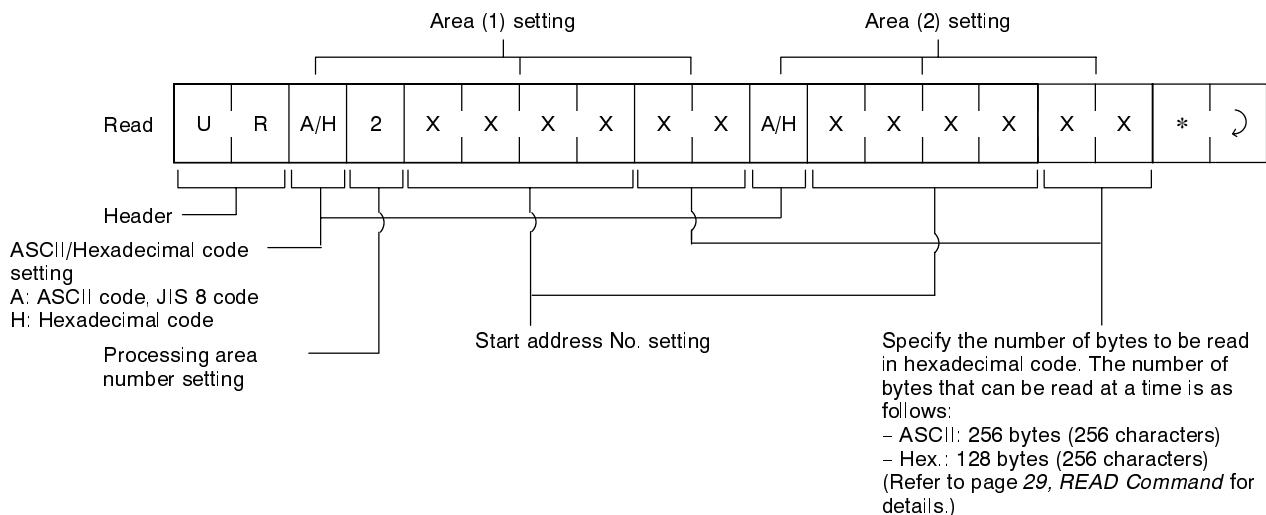

Response Format

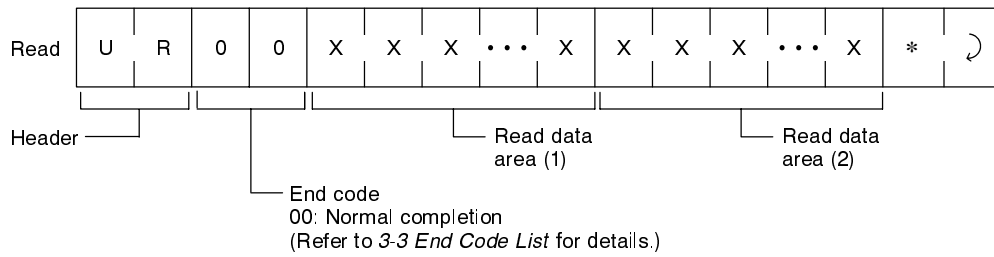

3-2-9 BUTTON AUTO WRITE (UW)

After the Hand-held Reader Writer has received the BUTTON AUTO WRITE command, data will be written from the Data Carrier after the activate switch is pressed and the Hand-held Reader Writer is held close to the Data Carrier. The Hand-held Reader Writer will give a response once communications with the Data Carrier are complete.

One Processing Area

Command Format

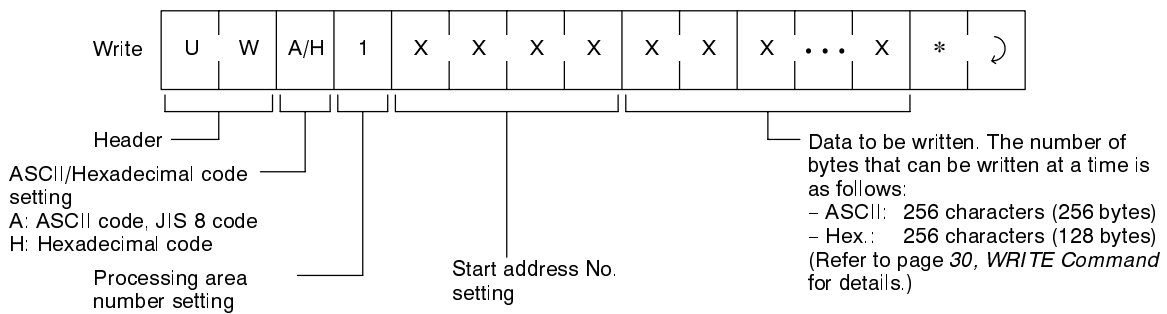

Response Format

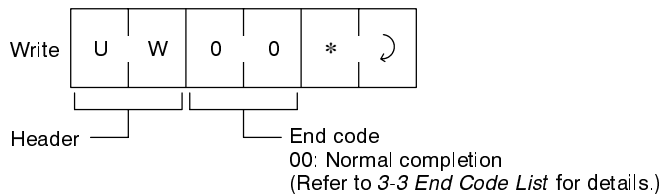

Two Processing Areas

Command Format

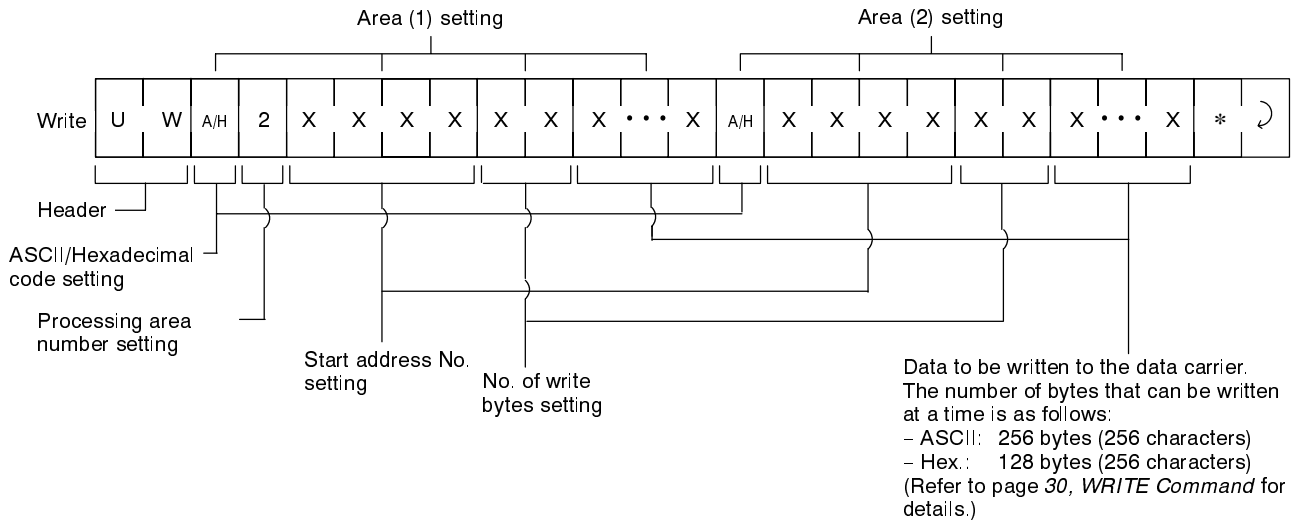

Response Format

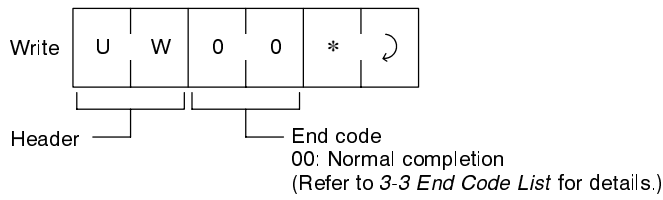

3-2-10 FILL (FL)

The specified memory area of the Data Carrier is filled with setting data.

Command Format

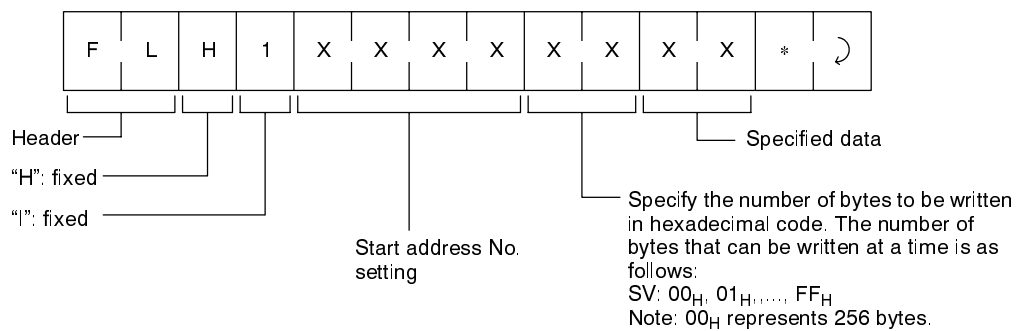

Response Format

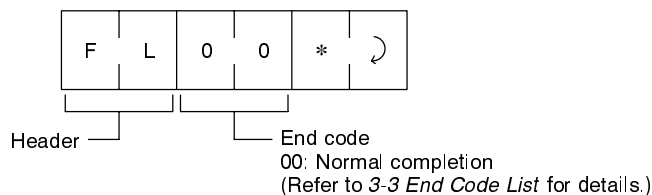

Example

When 01 is written in the memory area from byte address 0030_H to the 35_H memory area, the Data Carrier will be written with the same data as the address.

002F _H	2	F
0030 _H	3	0
0031 _H	3	1
0032 _H	3	2
0033 _H	3	3
0034 _H	3	4
0035 _H	3	5
0036 _H	3	6

Command: Execute FLH100300001*

Response: FL00*

002F _H	2	F
0030 _H	0	1
0031 _H	0	1
0032 _H	0	1
0033 _H	0	1
0034 _H	0	1
0035 _H	0	1
0036 _H	3	6

3-2-11 COMMAND PROCESSING TERMINATE (AA)

Terminates the processing of the auto commands, button commands, and button auto commands and restores the command wait status.

One Processing Area

Command Format

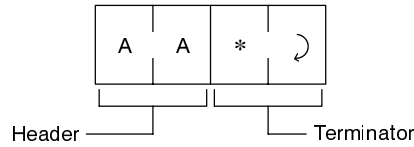

Response Format

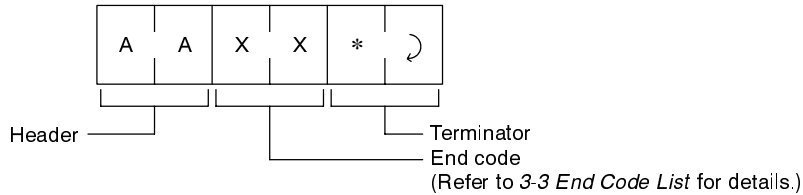

End code	Meanings
14	Auto command processing not executed
75	This end code is returned when the AA command was received while the Hand-held Reader Writer was in command wait status (before the Data Carrier arrived.)
76	This end code is returned when the AA command was received while the auto command was being executed. (If an AUTO WRITE command is terminated during execution, part of the data may have been written to the memory area of the Data Carrier.)

3-2-12 DATA CHECK (MDC/K)

Writes and collates the CRC code as a unit of the check block specified by the user. The CRC code is calculated by the polynomial expression generated; $X^{16} + X^{12} + X^5 + 1$.

Command Format

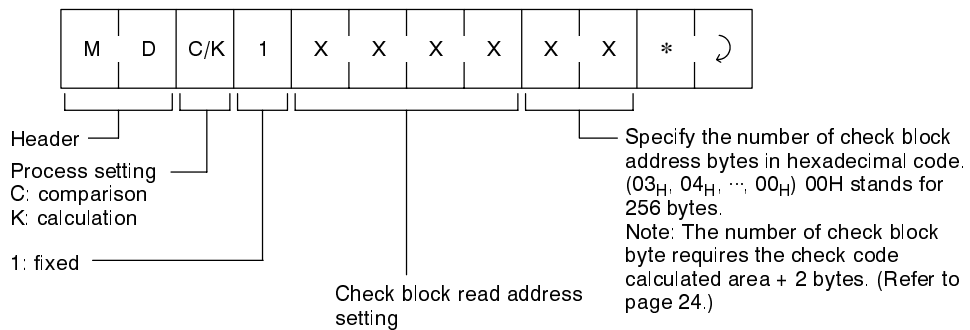

Response Format

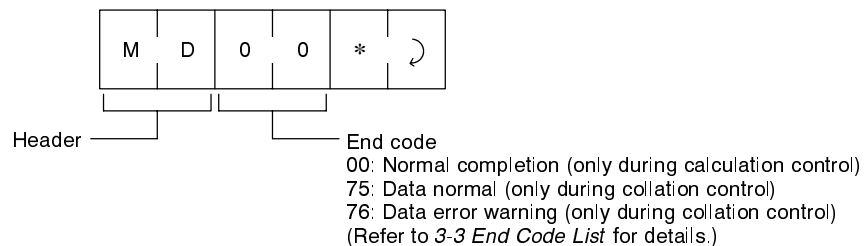

3-2-13 Rewrite Count CONTROL (MDS)

The DATA CONTROL command performs DATA CONTROL for EEPROM Data Carriers. The specified count is subtracted from the user specified data processing area, and whether or not the EEPROM overwrite count has been exceeded will be determined.

Command Format

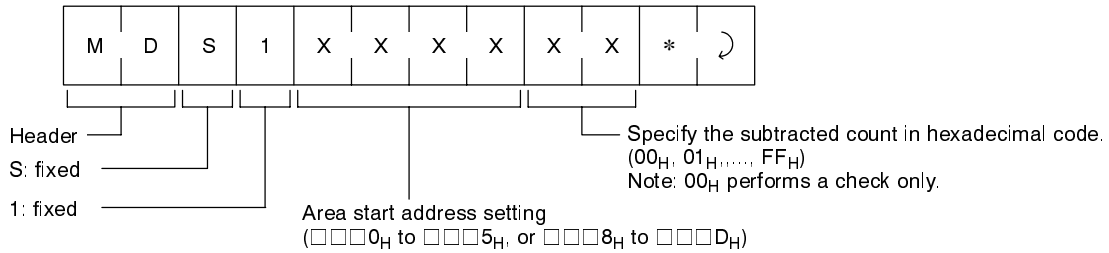

Response Format

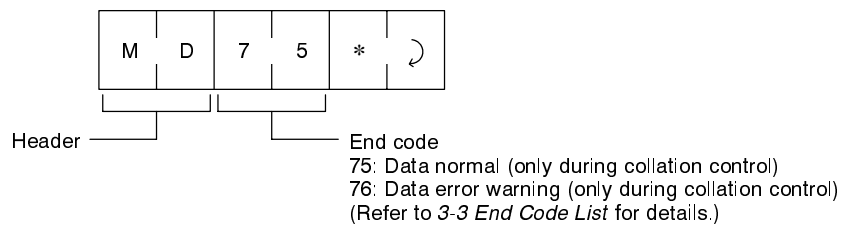

3-2-14 TEST (TS)

Returns a test message sent from the host computer as is. The TEST command is used to test communications between the host computer and the Hand-held Reader Writer.

Command Format

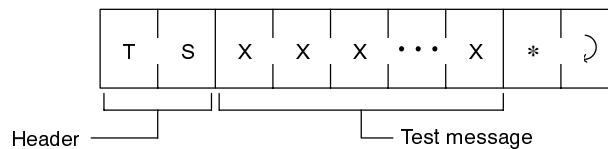

Response Format

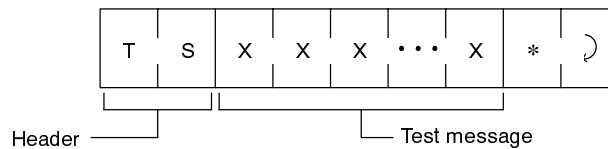

3-2-15 ABORT (XZ)

If the Hand-held Reader Writer does not return a response due to a problem during host communications or lower communications, the ABORT command will be able to restore the Hand-held Reader Writer to the command wait status. There will be no response to the ABORT command.

Command Format

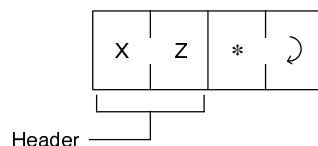

Note The Hand-held Reader Writer requires about 100 ms to get ready for reception of the next command after it receives the ABORT command.

3-2-16 COMMUNICATIONS CONDITIONS SETTING (TR)

Sets the serial communications conditions. After modifying the setting it will be necessary to restart the Hand-held Reader Writer in order to operate with the modified settings.

Command Format

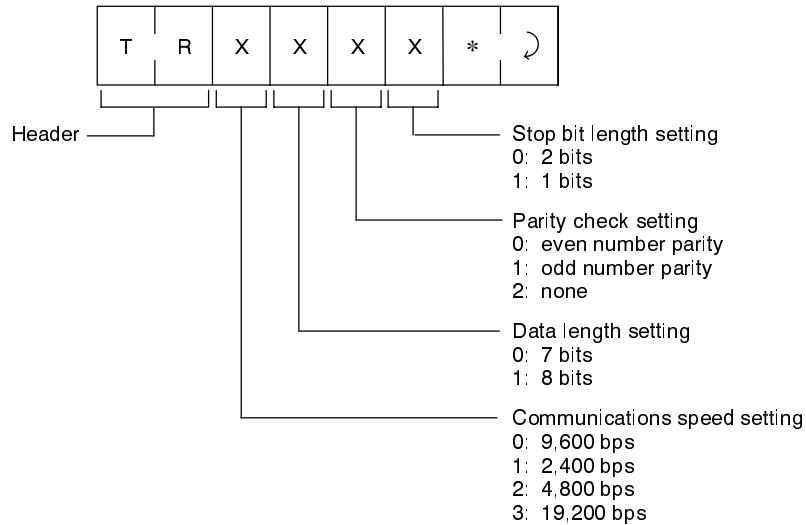

Response Format

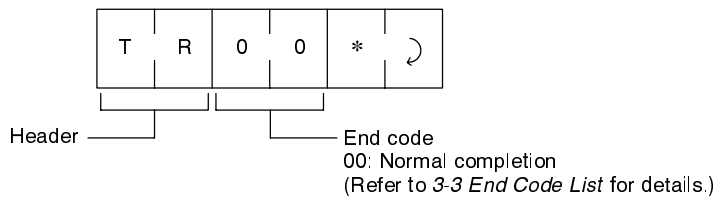

3-2-17 BASIC FUNCTIONS SETTING (FN)

Performs the setting of the Auto Command Off and Normal Operation Output functions. After modifying the setting, the Hand-held Reader Writer must be restarted in order to operate the Hand-held Reader Writer using the modified settings.

Command Format

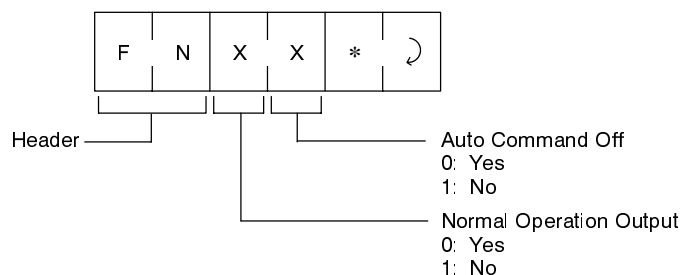

Response Format

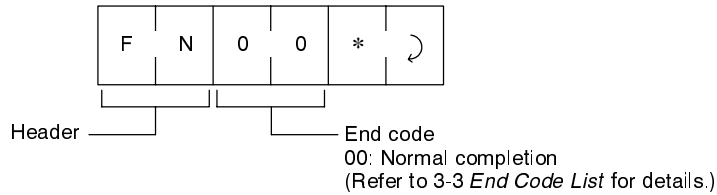

3-2-18 SET INFORMATION READ (UL)

Reads the Hand-held Reader Writer setting information.

Command Format

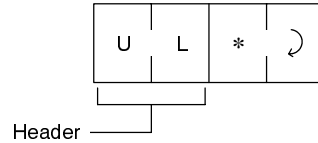

Response Format

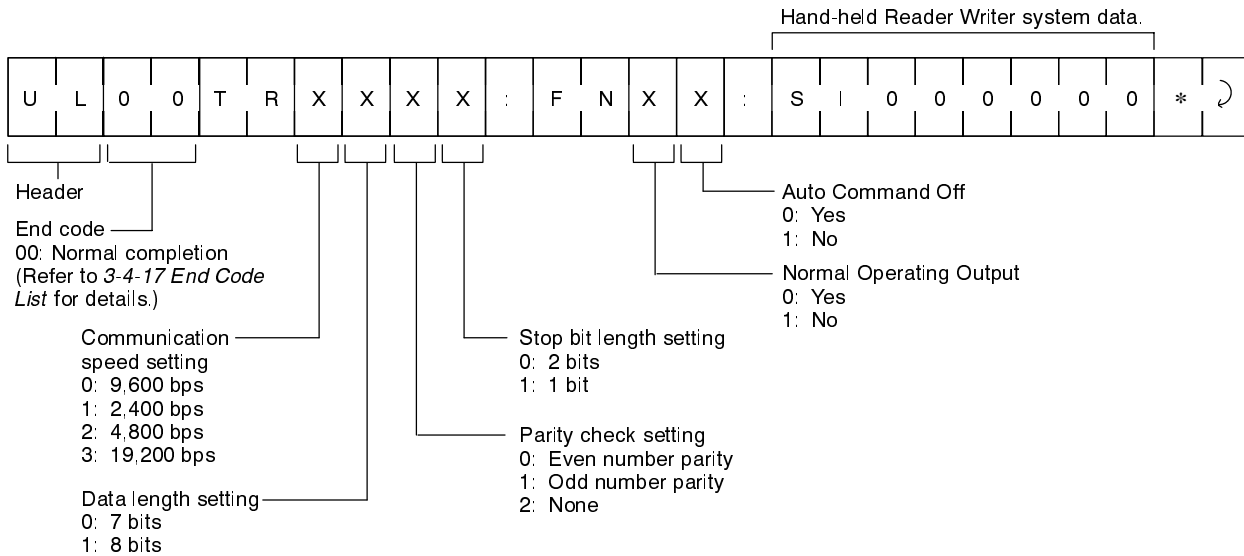

3-2-19 Command Undefined Response (IC)

This is a response the Hand-held Reader Writer will return if it cannot read the header of a given command.

Response Format

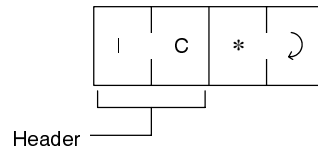

3-2-20 Error Response

If an error occurs during the host communication or lower communication, the error will be identified by the end code.

Response Format

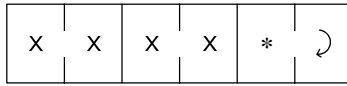

Header

End code

(Refer to 3-3 End Code List for details.)

The header is same as that of the transmitted command.

3-3 End Code List

The end code is expressed with a 2-digit hexadecimal number.

Type	End code	Description
Normal	00	Normal completion
	7B	Normal completion, but Data Carrier battery needs to be replaced. (see note 1)
	75	Stops the command auto processing (before communications with the Data Carrier)
	76	Stops the command auto processing (during communications with the Data Carrier)
Host communication	10	Vertical parity error
	11	Framing error
	12	Overrun error
	14	Command input error
	18	Frame length MAX error
Lower communication	70	Data Carrier communication error
	71	Unmatching error
	72	Data Carrier missing error
	7A	Address error
	7D	Write protect error
Data Carrier	75	For data check or DATA PROCESSING commands Normal end code (no errors)
Memory warning	76	For data check or DATA PROCESSING commands Error end code (error exists)
Memory error	93	EEPROM memory error

- Note**
1. When a “7B” error code is returned, the command was completed normally, but the battery voltage is low. If the battery voltage is so low that a response cannot be returned, an error code such as “72” will result.
 2. Refer to the 5-1 Error Table for details on each error code.

3-4 Communications Time

Communications time differs according to the type of Data Carrier memory (SRAM or EEPROM). TAT (Turn Around Time) and communications time are displayed as communication times. TAT represents the total time from when a command is first sent from the host device to when a response is received. The communications time represents the time required for communications between the Hand-held Reader Writer and the Data Carrier – not including communications with the host device.

Example

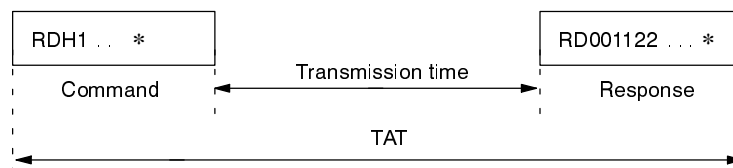

SRAM Data Carrier

TAT

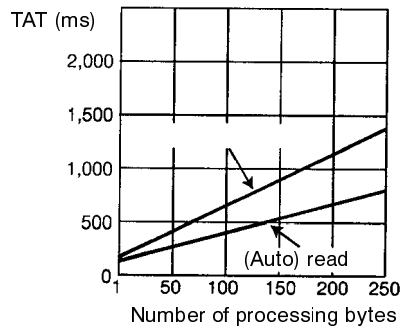

Transmission Time

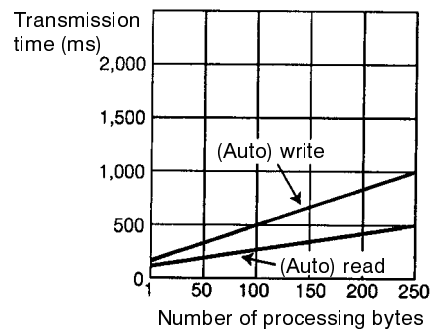

Calculation Method

(msec)

Item	Communication time
Read	$T = 1.5 N + 135.6$
Write	$T = 3.5 N + 193.3$

EEPROM Memory Data Carrier

TAT

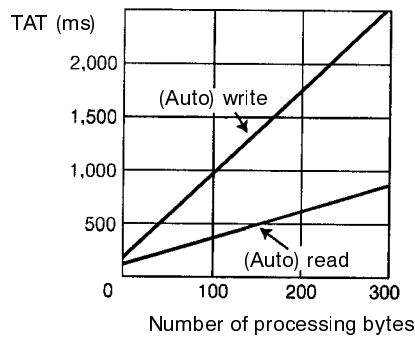

Transmission Time

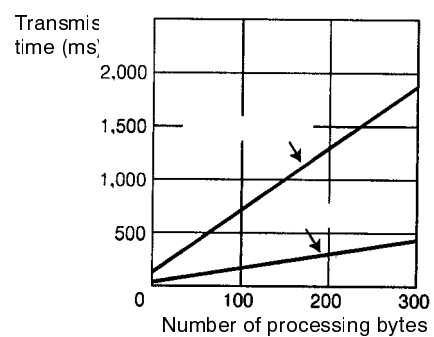

Calculation Method

(msec)

Item	Communications time
Read	$T = 1.6 N + 157.3$
Write	$T = 6.3 N + 244.3$

- Note**
1. These values represent the communication specifications for a TAT data host device of: baud rate: 9,600 bps; bit length: 7 bits; stop bit: 2 bits; even number parity.
 2. The number of TAT data bytes is the number of bytes when ASCII code is specified.

SECTION 4

Using the Hand-held Reader Writer

This section explains how to connect the Hand-held Reader Writer to a host device and provides a communications program example.

4-1	Connection with the Host Device	52
4-2	Communications Program Example	53

4-1 Connection with the Host Device

Use the following procedures when connecting the V600-CH1D.

- 1, 2, 3...
1. Create the application software. Refer to page 53 for a sample program example.
 2. Connect the V600-CH1D to the RS-232C interface of the host device.
 - **Connecting to a IBM-PC/AT or Compatible Computer (9-pin D-sub connector)**

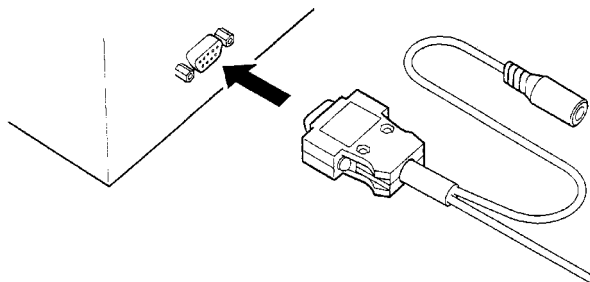

3. Connect an AC adapter to the V600-CH1D.

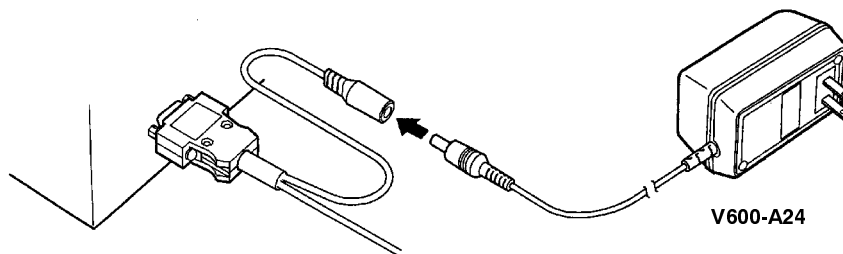

4. Insert the AC adapter into the receptacle.

**Caution**

Do not use an adapter other than the specified AC adapter. If an AC adapter other than one specified, the product may malfunction, be damaged, or burn. A conversion connector may be required depending on the device.

4-2 Communications Program Example

The IBM PC/AT or compatible computer and BASIC program for using the Hand-held Reader Writer V600-CH1D is provided below.

BASIC Program Example

This program writes data in hexadecimal code with the WRITE command from the Hand-held Reader Writer to the Data Carrier. The programming address is in the range of 0006_H to 07FF_H, and there must be an even number of characters since data can only be written in whole bytes and 2 hexadecimal characters make up one byte. Up to 256 characters can be entered. Set the communication protocol of the Hand-held Reader Writer with its DIP switch to match the protocol of the host computer.

```
10 CLS
20 OPEN "COM1:9600,E,7,3,CSO,DSO,CDO,PE" AS#1
30 WIDTH #1,255
40 PRINT "Writing hexadecimal data to the DC."
50 INPUT "Starting address? (Hexadecimal data: 006F-07FF)";WA$
60 INPUT "Input data (an even number of hexadecimal digits).";WD$
70 TX$="WTH1"+WA$+WD$+"*"+CHR$(&HD)
80 PRINT TX$
90 PRINT #1, TX$;
100 INPUT #1, RX$
110 PRINT "RS data=";RX$
120 GOTO 40
```

SECTION 5

Troubleshooting

This section describes the types of errors that can occur and provides troubleshooting flow charts.

5-1	Error Table	56
5-1-1	Transfer Stop Errors	56
5-1-2	Transfer Continuation Errors	56
5-2	Troubleshooting Flowchart	57

5-1 Error Table

5-1-1 Transfer Stop Errors

If a transfer stop error occurs, the mode display LED will be red and all operations of the Hand-held Reader Writer will stop until the power is switched OFF then ON again. For memory errors, however, communications with the host will still be possible.

Name	Description
Hardware trouble	Hand-held Reader Writer cannot be operated normally.
Memory trouble	Hand-held Reader Writer back-up memory contents are destroyed.

5-1-2 Transfer Continuation Errors

If a transfer continuation error occurs, the mode display LED will flash red for 2 seconds and an error code will be sent to the host device.

Name	Description
Parity error	Parity error generated during communications with the host device.
Framing error	Framing error generated during communications with the host device.
Overrun error	Over-run error generated during communications with the host device.
Command input error	Command from the host device is incorrect.
Frame length MAX error	Command exceeding the maximum frame length received.
Data Carrier communication error	Communications with the Data Carrier was not performed correctly.
Unmatching error	Write control was not performed correctly.
Data Carrier missing error	A command was issued which was not an auto command when the Data Carrier was not in the communications area. Command Off occurred with the auto command.
Address error	An address was designated which exceeded the Data Carrier memory area.
Write protect error	The manufacturing date or the write protect area was designated with a WRITE command.

5-2 Troubleshooting Flowchart

When an error occurs, be sure to understand the conditions thoroughly, then accurately determine the likelihood of the error re-occurring or whether the problem is related to another machine, etc., and follow the flowchart provided below.

System Connection Check

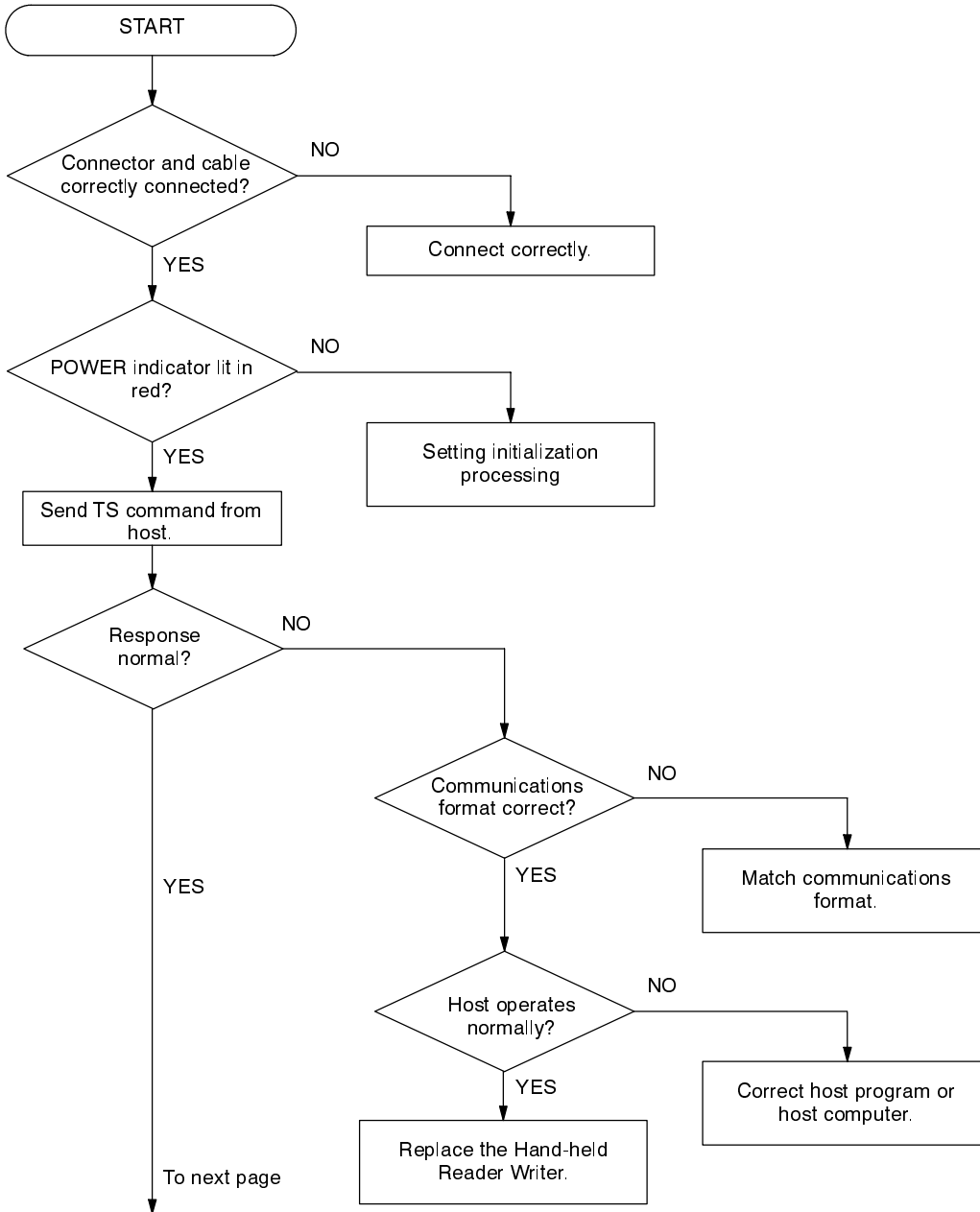

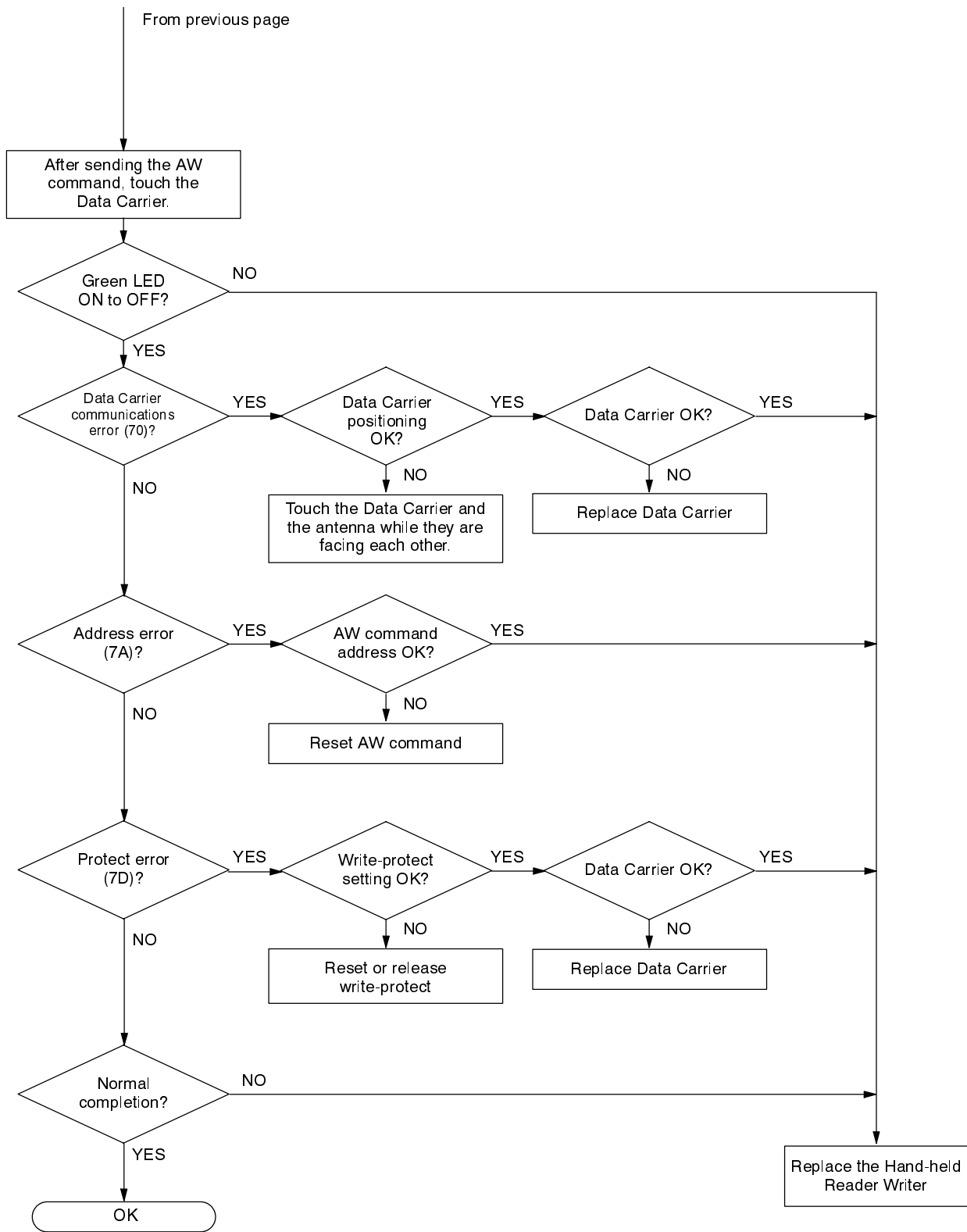

Appendix A

JIS 8 Code List (ASCII List)

Higher digits	b8~b5	0000	0001	0010	0011	0100	0101	0110	0111	1000	1001	1010	1011	1100	1101	1110	1111	
Lower digits	b4~b1	Row Column	0	1	2	3	4	5	6	7	8	9	10	11	12	13	14	15
0000	0	NUL	TC ₇ (DLE)	(SP)	0	@	P	`	p									
0001	1	TC ₁ (SOH)	DC ₁	!	1	A	Q	a	q									
0010	2	TC ₂ (STX)	DC ₂	"	2	B	R	b	r									
0011	3	TC ₃ (ETX)	DC ₃	#	3	C	S	c	s									
0100	4	TC ₄ (EOT)	DC ₄	\$	4	D	T	d	t									
0101	5	TC ₅ (ENQ)	TC ₅ (NAK)	%	5	E	U	e	u									
0110	6	TC ₆ (ACK)	TC ₆ (SYN)	&	6	F	V	f	v									
0111	7	BEL	TC ₀ (ETB)	'	7	G	W	g	w	Undefined	Undefined	Undefined	Undefined	Undefined	Undefined	Undefined	Undefined	Undefined
1000	8	FE ₀ (BS)	CAN	(8	H	X	h	x	Undefined	Undefined	Undefined	Undefined	Undefined	Undefined	Undefined	Undefined	Undefined
1001	9	FE ₁ (HT)	EM)	9	I	Y	i	y									
1010	10	FE ₂ (LF)	SUB	*	:	J	Z	j	z									
1011	11	FE ₃ (VT)	ESC	+	;	K	[k	{									
1100	12	FE ₄ (FF)	IS ₄ (FS)	,	<	L	\	l										
1101	13	FE ₅ (CR)	IS ₃ (GS)	-	=	M]	m	}									
1110	14	S0	IS ₂ (RS)	.	>	N	^	n	~									
1111	15	S1	IS ₁ (US)	/	?	O	_	o	DEL									

- Note**
1. The code at the 5th row, 12th column is “\” in ASCII code.
 2. Do not use the undefined areas.

Appendix B

Data Carrier Memory Capacity and Memory Type

Model	Memory capacity (user memory)	Memory type	Life expectancy
V600-D8KR12 V600-D8KR13 V600-D8KR04	8 Kbytes	SRAM	8 years (at -25°C to 70°C) 5 years (at -25°C to 70°C) 8 years (at -25°C to 70°C)
V600-D2KR16	2 Kbytes	SRAM	2 years (25°C)
V600-D23P53 V600-D23P54 V600-D23P61 V600-D23P81	254 bytes	EEPROM	Write operations: 300,000 times for each address (at -20°C to 40°C) 100,000 times for each address (at -20°C to 70°C) Data retention 10 years (at -40°C to 85°C)
V600-D23P66 V600-D23P66SP V600-D23P71 V600-D23P72	254 bytes	EEPROM	Write operations: 300,000 times for each address (at -20°C to 40°C) 100,000 times for each address (at -20°C to 70°C) Data retention 10 years (at -40°C to 110°C)

Index

A

ABORT, command format, 44

address range

 READ command, 29

 WRITE command, 30

ASCII, 59

AUTO READ

 command format, 35

 response format, 35

AUTO WRITE

 command format, 36

 response format, 36

B

BASIC FUNCTIONS SETTING

 command format, 45

 response format, 46

BUTTON AUTO READ

 command format, 39

 response format, 39, 40

BUTTON AUTO WRITE

 command format, 40, 41

 response format, 40, 41

BUTTON READ

 command format, 37

 response format, 37

BUTTON WRITE

 command format, 38

 response format, 38

bytes

 READ command, 29

 WRITE command, 30

C

checking the system, system connection check, 57

codes, 59

 end codes, 48

command, list, 32

COMMAND PROCESS TERMINATE, command format, 43

COMMAND PROCESSING TERMINATE

 end code, 43

 response format, 43

command undefined, response format, 46

communications, specifications, 8

COMMUNICATIONS CONDITIONS SETTING

 command format, 45

 response format, 45

communications time, 48

connections, host device, 52

D

Data Carrier

 detecting battery life, 22

 memory, 17

 memory check function, 24

DATA CHECK

 command format, 43

 response format, 43

data code

 ASCII, 28

 hexadecimal code, 29

 JIS 8 code, 28

DATA CONTROL

 command format, 44

 response format, 44

dimensions, 8

E

end code list, 48

error, response format, 47

errors, transfer continuation errors, 56

F

features, 2

 auto command off, 15

 normal operation output, 16

FILL

 command format, 41

 response format, 41

formats, command/response, 28

functions, write protect, 18

J—P

JIS 8 code, 59

performance, 5

programming example, host link serial system, 53

R

READ

 command format, 33

 response format, 33

read, command format, 23, 24
response, list, 32
RS-232C, 3

S

SET INFORMATION READ
 command format, 46
 response format, 46
settings, 16
specifications, 5, 7
 transmission, 9
system configuration, 3

T

TEST
 command format, 44
 response format, 44
transmission range, 11

W

WRITE
 command format, 34
 response format, 34
write, response format, 23, 24
write protect, 18

Revision History

V600 ID System Hand-held Reader Writer

Operation Manual

A manual revision code appears as a suffix to the catalog number on the front cover of the manual.

Cat. No. Z122-E3-1

↑
Revision
code

The following table outlines the changes made to the manual during each revision. Page numbers refer to the previous version.

Revision code	Date	Revised content
Z122-E1-1	February 1998	Original production
Z122-E3-1	June 1998	1-2 System Configuration, made changes from Hand-held ID to Hand-held PC. Also made changes to Note on bottom of page 3. 2-2-1 General, added text in table. 2-4-1 Host Communications Interface Specifications, Added text in table. 2-5 Host Interface Connector Pin Layout, replaced table with the one in V600CH1D Data Sheet. 3-1-2 Two or More Processing Areas, added some new text. 3-2-3 WRITE (WT), added new note to replace old text in graphic. 3-2-5 AUTO WRITE (AW), changed look of graphic slightly. Two or More Processing Areas, added some new text. 3-2-7 BUTTON WRITE (BW), added new note to replace old text in graphic. 3-2-9 BUTTON AUTO WRITE (UW) added new note to replace old text in graphic. 4-1 Connection with the Host Device, deleted • Connecting to a CQM1 Programmable Controller information and table.



OMRON ELECTRONICS LLC

1 Commerce Drive
Schaumburg, IL 60173
847.843.7900
For US technical support or
other inquiries: 800.556.6766

OMRON CANADA, INC.

885 Milner Avenue
Toronto, Ontario M1B 5V8
416.286.6465

OMRON ON-LINE

Global - <http://www.omron.com>
USA - <http://www.omron.com/oei>
Canada - <http://www.omron.ca>

UNITED STATES

To locate a Regional Sales Office, local Distributor or
to obtain product information, call: 847.843.7900

CANADA REGIONAL SALES OFFICES

Ontario	Toronto	416.286.6465
	Kitchener	519.896.1144
	Kingston	613.376.3968
Quebec	Montreal	514.636.6676
British Columbia	Vancouver	604.522.8855
Alberta	Edmonton	403.440.0818
	Calgary	403.257.3095

BRAZIL SALES OFFICE

Sao Paulo 55.11.5564.6488

ARGENTINA SALES OFFICE

Cono Sur 54.114.787.1129

MEXICO SALES OFFICES

Florida 954.227.2121 **Ciudad Juarez** 656.623.7083
Mexico, D.F. 555.534.1195 **Monterrey, N.L.** 818.377.4281