

V700 RFID System
Model V700-HMD11 Reader Writer

Operation Manual



Issued: July 7, 2000

Applicable Standards

FCC (USA) Part 15 subpart B and C

FCC NOTICE

This equipment has been tested and found to comply with the limits for a Class B digital device, pursuant to part 15 of the FCC Rules. These limits are designed to provide reasonable protection against harmful interference in a residential installation.

This equipment generates, uses and can radiate radio frequency energy and, if not installed and used in accordance with the instructions, may cause harmful interference to radio communications. However, there is no guarantee that interference will not occur in a particular installation. If this equipment does cause harmful interference to radio or television reception, which can be determined by turning the equipment off and on, the user is encouraged to try to correct the interference by one or more of the following measures:

- Reorient or relocate the receiving antenna.
- Increase the separation between the equipment and receiver.
- Connect the equipment into an outlet on a circuit different from that to which the receiver is connected.
- Consult the dealer or an experienced radio / TV technician for help.

FCC WARNING

Changes or modifications not expressly approved by the party responsible for compliance could void the user's authority to operate the equipment.

Properly shielded and grounded cables and connectors must be used for connection to host computer and / or peripherals in order to meet FCC emission limits.

AC adapter with ferrite core must be used for RF interference suppression.

Precautions of Use

This device uses a frequency of 125 kHz to communicate with a tag. Some transceivers, motors, monitor units, and power supply (power IC) emit noise that adversely affects this communication with the tag. If this product is to be used in an environment close to such devices, please check the effects from these devices prior to use.

To minimise the effect of noise, please ground any metal object surrounding this device.

This manual describes the specifications and transmission format of the Model V700-HMD11 Reader Writer.

Table of Contents

| | |
|---|----|
| 1. Product Outline | 4 |
| 2. Specifications and Performance | 4 |
| (1) Shape | 4 |
| (2) General Specifications | 5 |
| (3) High-end Interface Specifications | 6 |
| 3. Operations of the Reader Writer | 7 |
| 3.1 Outline of Operations | 7 |
| Oscillation Control | 7 |
| 3.3 Memory Management on Tag | 8 |
| 3.4 Processing of Tag Memory | 9 |
| (1) Process Contents | 9 |
| (2) Transmission Operations | 10 |
| 4. Controlling the Reader Writer from High-end Devices | 13 |
| 4.1 Communication Frame | 13 |
| 4.2 Command/Response Format | 13 |
| (1) Commands | 13 |
| (2) Transmission Option | 14 |
| (3) Completion Code | 15 |
| 4.3 Commands Types and Responses | 16 |
| (1) Read | 16 |
| (2) Write | 17 |
| (3) Multiple Write | 18 |
| (4) Byte Write | 19 |
| (5) Write Protection | 20 |
| (6) ACK | 21 |
| (7) NACK | 21 |
| (8) STOP | 21 |
| (9) Oscillation ON / OFF | 22 |
| (10) Test | 22 |
| 5. Transmission Specification (Reference Values) | 23 |
| 5.1 Transmission Distance | 23 |
| 5.2 Transmission Area | 24 |
| 5.3 Communication Time | 25 |
| (1) Transmission Time | 25 |
| (2) TAT | 25 |
| 6. The Influence of Requirements of Use on Transmission Distance (Reference Values) | 26 |
| 6.1 Influence of Metal Objects Surroundings and Metal Objects Behind the Device | 26 |
| 6.2 Mutual Interference between Reader Writers | 28 |
| 6.3 Effects of Antenna Angle | 29 |
| Appendix 1 Document Revision History | 30 |

1. Product Outline

Model V700-HMD11 is an integrated unit of the transmission/reception circuit and control function, for communication with a Model V700 Series tag. This model is a small type reader/writer, which can be connected to higher end devices through an RS232 interface.

2. Specifications and Performance

(1) Shape

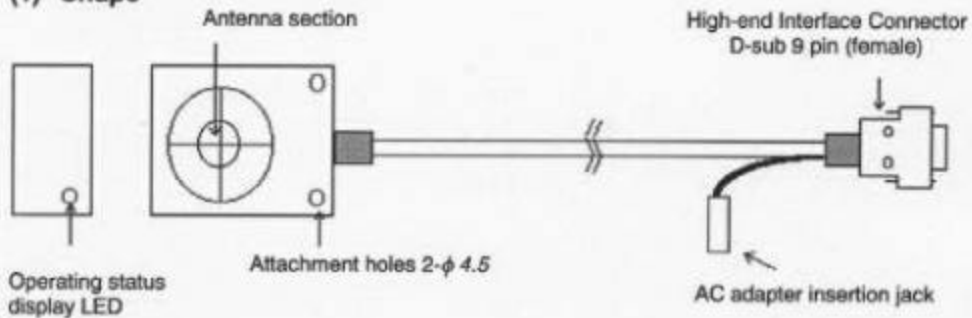

- Operating status displaying LED

| LED Display | Detail |
|-------------|---|
| Green | Lights on when communicating with the Tag |
| Red | Lights on when the communication process does not terminate successfully. |

- High-end Interface Connector
This connector is a D-sub 9-pin (female) type, complying with RS232 interface.
- AC Adapter Insertion Jack
This is a jack for connecting a dedicated AC adapter (to be procured locally).
- Antenna Section
When communicating with the tag, please bring the tag close to the antenna.

(2) General Specifications

| Item | Specifications | Remark |
|----------------------------------|---|--|
| Mounting method | 2 points, secured by M4 screws | Can be installed on any metal board *. |
| Power supply | 5V \pm 5% | Power is supplied from a dedicated AC adapter. |
| Current consumption | 200 mA or less (in oscillation) 25 mA or less (no oscillation) | |
| Insulation resistance | 50 m Ω between the cable terminal and case (applying 500MV DC) | |
| Dielectric strength | AC1000V between the cable terminal and case, 50/60Hz, 1 min. | |
| Noise immunity | Power line: 1200Vp-p I/O line: 800Vp-p | |
| Vibration resistance | 10 to 150 Hz, 0.75 mm one-way amplitude, 100m/s ² acceleration, 8 min. \times 4 times in 3 directions respectively | |
| Shock resistance | 300m/s ² , 3 times in 6 directions respectively | |
| Protection rating | IP67 (IEC60529 standard) IP67G (JEM1030 standard) | |
| Ambient temperature in operation | -10 to +55°C | |
| Ambient temperature in operation | -25 to +65°C | |
| Ambient humidity in operation | 25 to 85% RH or less (no condensation) | |
| Radio frequency | 125 kHz | |
| Cable length | 2 m | The RS232 signal line can be extended up to 15m. |
| Net weight | Approximately 210 g | |

* To install this product on a metal board, always ground the metal board.

(3) High-end Interface Specifications

| Item | Specifications | | | | |
|------------------------------|---|----------|------------|----------|-------|
| Connector | D-sub 9-pin connector, female (applies to DOS/V machines) | | | | |
| Communication method | RS232 compliant | | | | |
| Synchronisation method | Asynchronous mode, start-stop synchronisation method | | | | |
| Communication control method | One to one procedure | | | | |
| Transmission speed (fixed) | 9600 bps | | | | |
| Character format (fixed) | Start bit | Data bit | Parity bit | Stop bit | Total |
| | 1 | 8 | Even | 1 | 11 |
| Error detection method | Even parity | | | | |

■ Pin Assignment and Connection with High-end Devices

Pins are assigned for DOS/V machines.

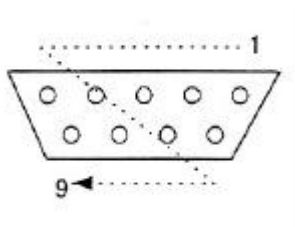

| Pin No. | Name | Abbreviation | Signal direction |
|---------|-------------------|--------------|-----------------------------------|
| 1 | Carrier detection | CD | Connected to DR in the connector. |
| 2 | Receive data | RD | Upper device ← reader/writer |
| 3 | Send data | SD | Upper device → reader/writer |
| 4 | - | - | - |
| 5 | Signal ground | SG | - |
| 6 | Data set ready | DR* | Upper device ← reader/writer |
| 7 | Request to send | RS | Looped back in the connector. |
| 8 | Send possible | CS | |
| 9 | - | - | - |

* DR is always ON when this product is operating.

3. Operations of the Reader Writer

3.1 Outline of Operations

The Reader Writer receives commands from the High-end device, executes read / write processes on the Tag, and returns a response of the results of the process to the High-end device. The status of the Reader Writer operations will be reflected on the Output / LED.

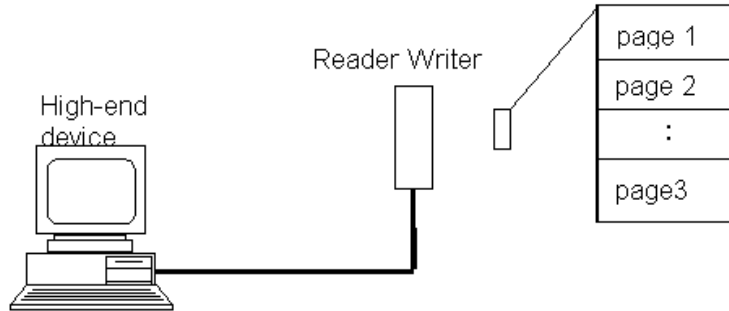

■ Operations Timing Chart

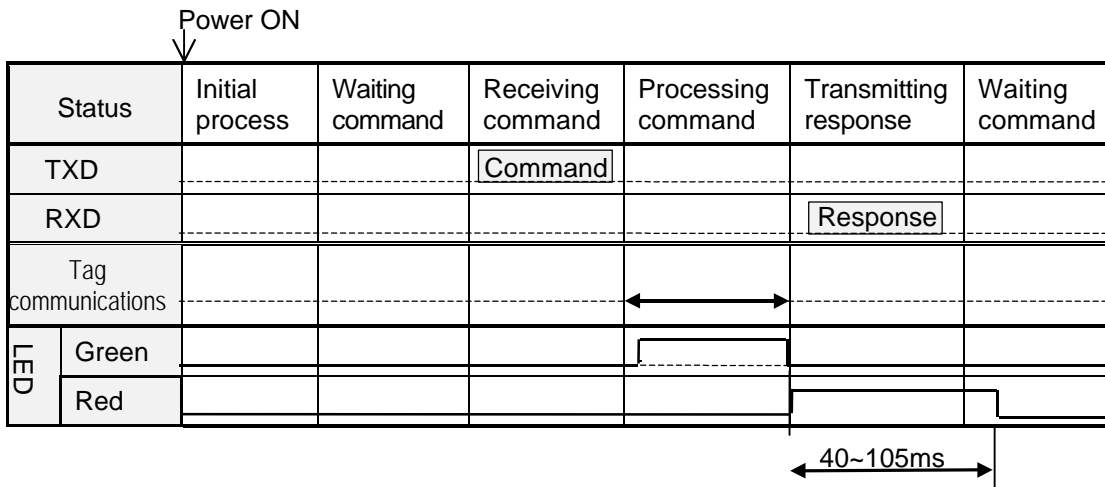

3.2 Oscillation Control

The Reader Writer supplies power to the Tag by oscillating the antenna, and thus conducts communication with the Tag. The Reader Writer may be set on either the "Oscillate Mode" "Stop Mode" depending on whether the Reader Writer should oscillate while not in communication with the Tag. The "Stop Mode" conserves dissipation power, and enables the Reader Writer antenna to be installed close to the Tag to conduct communications on a time sharing basis. The "Oscillate Mode" allows the Reader Writer to constantly supply power to the Tag for FIFO processing.

| Oscillation Status | Operation | Mode Switching Conditions |
|---|---|--|
| Stop Mode (conserves dissipation power) | The antenna stops oscillating while not processing commands | <ul style="list-style-type: none"> When power is start-up When oscillation OFF command is executed |
| Oscillation Mode (enables high-speed processing) | The antenna is constantly oscillating | <ul style="list-style-type: none"> When oscillation ON command is executed When option data of FIFO Trigger / FIFO Auto Commands is executed |

3.3 Memory Management on Tag

There are two types of the tag in the memory capacity: 128 bytes (user area 112 bytes) and 256 bytes (user area 240 bytes). The memory area recognises every 8 bytes as one page, distinguished by such addresses as 00h ~ 07h, 08h ~ 0Fh, and so on.

■ Memory Map (00h ~ EFh indicates memory address)

| Page | 8 bytes / page | | | | | | | |
|------|----------------|-----|-----|-----|-----|-----|-----|-----|
| 1 | 00h | 01h | 02h | 03h | 04h | 05h | 06h | 07h |
| 2 | 08h | 09h | 0Ah | 0Bh | 0Ch | 0Dh | 0Eh | 0Fh |
| 3 | 10h | 11h | 12h | | ... | ... | | 17h |
| 4 | 18h | 19h | 1Ah | | ... | ... | | 1Fh |
| 5 | 20h | | | | | | | 27h |
| 6 | 28h | | | | | | | 2Fh |
| 7 | 30h | | | | | | | 37h |
| 8 | | | | | | | | |
| 9 | | | | | | | | |
| 10 | : | | | | | | | : |
| 11 | : | | | | | | | : |
| 12 | | | | | | | | |
| 13 | | | | | | | | |
| 14 | 68h | | | | ... | ... | | 6Fh |
| 15 | 70h | | | | ... | ... | | 77h |
| 16 | 78h | | | | ... | ... | | 7Fh |
| : | : | | | | | | | : |
| : | : | | | | | | | : |
| 29 | E0h | E1h | | | ... | ... | | E7h |
| 30 | E8h | E9h | | | ... | ... | | EFh |

3.4 Processing of Tag Memory

(1) Process Contents

The following three processes are executed on the Tag Memory

1) Data Read

Reading data from Tag Memory in units of pages. The area to execute the Read command is selected at random up to 16 pages (CR control) / 28 pages (Number of characters control).

2) Data Write

Writing data onto Tag Memory. The area to execute the Write command may be selected at random up to 16 pages (CR control) / 28 pages (Number of characters control). When writing the same data onto all pages (multiple write), there is no limitation on the number of pages. Certain data may be selected in units of bytes to be written onto the Tag Memory (byte write).

3) Write Protection Set/Clear

Write protection is set on the selected pages of Tag Memory. When write protection is set, the data may be read, but not be written. Write protection may be set on any of the pages. Write protection may be set or turned off by commands. Set / Clear is conducted by using the write protect command (08).

(2) Transmission Operations

The following 6 transmission operations are executed by changing the process procedure and execution timing. Transmission operations are specified by commands during command transmission.

1) Single Trigger

Transmission with Tag is executed immediately after receiving command and a response is transmitted. After response is transmitted, the Reader Writer will be on stand by for new commands. During transmission with the Tag, there must be only one Tag within the transmission area.

◆ Operation Sequence

Processing is executed once only after receiving command. If there is no Tag, a Tag absent error message will be transmitted.

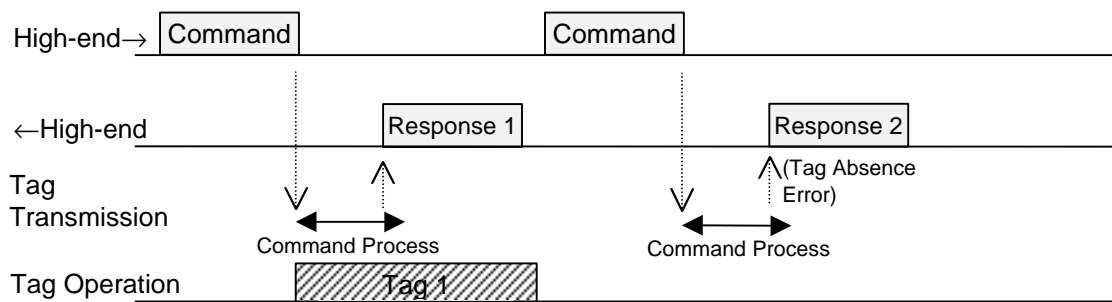

2) Single Auto

After receiving command, the Reader Writer waits for the Tag to approach, communicates with the Tag, and then transmits a response. Once the response is transmitted, the Reader Writer will be on stand by for new commands. During transmission with the Tag, there must be one Tag within the transmission area.

◆ Operation Sequence

After receiving command, the Reader Writer waits for the Tag to approach, then executes process once only after Tag is detected. When the Reader Writer receives a STOP command, the command will be completed.

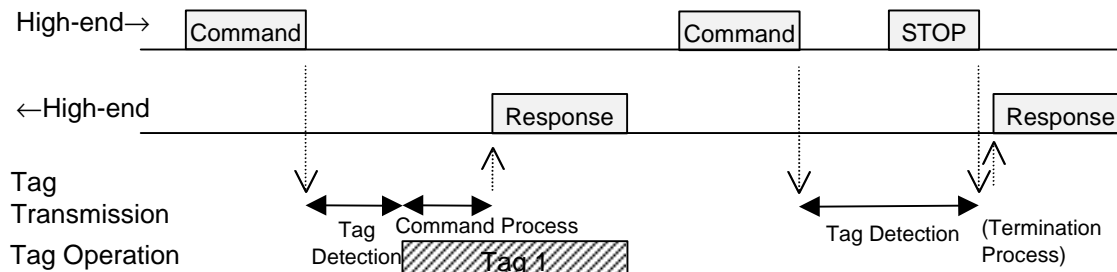

3) FIFO Trigger

The Reader Writer will communicate with Tag immediately after receiving command and transmit response. After transmission is completed, the Reader Writer will prohibit Tag from operating. The Reader Writer will be on stand by for commands after response is transmitted. During transmission with Tag, there MUST BE AN OPERATIONAL TAG (A TAG THAT IS NOT PROHIBITED FROM OPERATION) within the transmission area. When this command is executed, the Reader Writer automatically activates "Oscillation Mode"

◆ Operation Sequence

Upon receiving command, the Reader Writer will execute process once only. If there is no Tag, a Tag absence error will be transmitted. During processing of the command, Tag will become inoperative, and thus Tags that have completed transmissions will not respond to the next command. Oscillation will continue after command is processed.

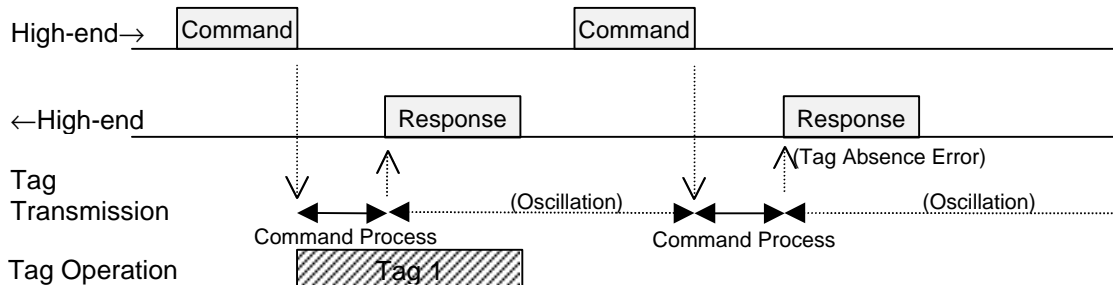

4) FIFO Auto

The Reader Writer will await Tag to approach after receiving command, then communicate with Tag and transmit response. After transmission is completed, the Reader Writer will prohibit Tag from operating. The Reader Writer will be on stand by after response transmission is completed. During transmission with the Tag, there MUST BE AN OPERATIONAL TAG (A TAG THAT IS NOT PROHIBITED FROM OPERATION) within the transmission area. When this command is executed, Module automatically activates "Oscillation Mode."

◆ Operation Sequence

After receiving command, the Reader Writer waits for the Tag to approach, then executes process once only after Tag is detected. During processing of the command, Tag will become inoperative, and thus Tags that have completed transmissions will not respond to the next command. Oscillation will continue after command is processed. When the Reader Writer receives a STOP command, the command will be completed. However, oscillation after completion of command continues.

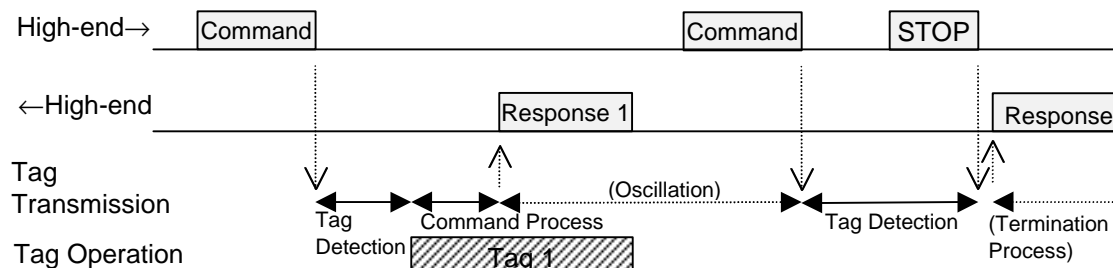

5) FIFO Continue

After waiting for the Tag to approach, then communicates with the Tag and transmits a response. After transmission is completed, Tag will become inoperative. After transmitting a response, the Reader Writer will await Tag to approach again if it receives [ACK], and CONTINUE UNTIL THE READER WRITER RECEIVES A STOP COMMAND. When communicating with the Tag, THERE MUST BE ONLY ONE ACTIVE TAG within the transmission area.

◆ Operation Sequence

Upon receiving the command, the Reader Writer awaits Tag to approach. When Tag is detected, the Reader Writer executes command and transmits a response. Afterwards, when [ACK] is received, the Reader Writer repeats the same operation. Once process is executed on a Tag, the Tag becomes inoperative, and thus a Tag will only be processed once. When the Reader Writer receives a STOP command, processing will stop.

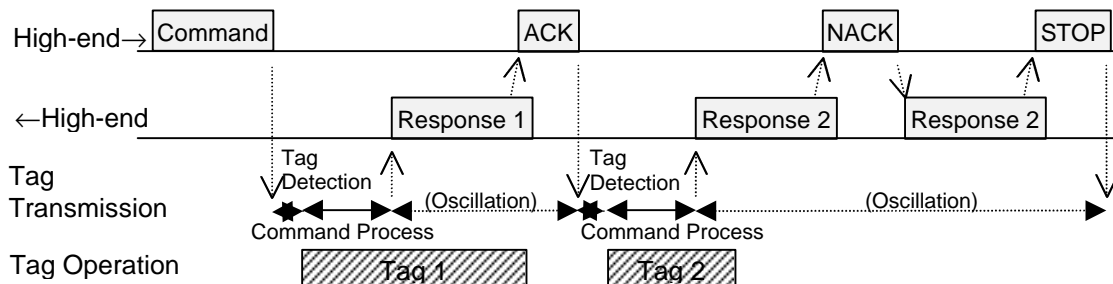

6) FIFO Repeat

After waiting for the Tag to approach, then the Reader Writer communicates with the Tag and transmits a response. After transmission is completed, Tag will become inoperative. THE READER WRITER WILL CONTINUE PROCESS UNTIL IT RECEIVES A STOP COMMAND. When communicating with the Tag, THERE MUST BE ONLY ONE ACTIVE TAG (A TAG THAT IS NOT PROHIBITED FROM OPERATION) within the transmission area.

◆ Operation Sequence

Upon receiving the command, the Reader Writer awaits Tag to approach. When Tag is detected, the Reader Writer executes command and transmits a response. Afterwards, the Reader Writer repeats the same operation. Once process is executed on a Tag, the Tag becomes inoperative, and thus a Tag will only be processed once. When the Reader Writer receives a STOP command, processing will stop.

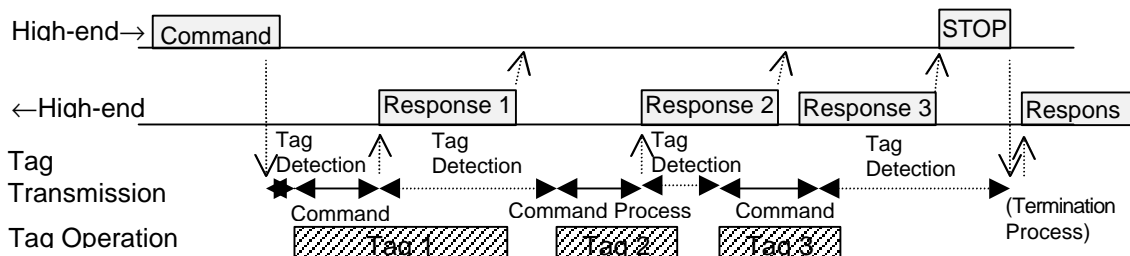

4. Controlling the Reader Writer from High-end Devices

4.1 Communication Frame

Frame format consists of 16 different types of data, "0" ~ "F," in units of even-number characters and a terminator [CR] (ASCII Code: 0Dh).

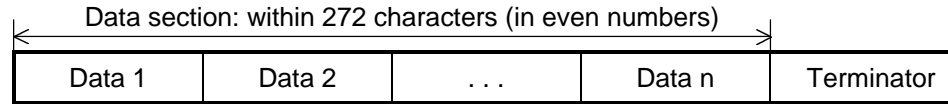

| Data | Number of characters | Details |
|------------|----------------------|---|
| Text | 0 ~ 272 | Parameters of each command ("0" ~ "F") |
| Terminator | 1 | Code [CR] (0Dh) indicating the completion of transmission frame |

(Communication Control Procedure)

Receipt commences when a character is received first, and when [CR] is received, the frame is recognised as finished. If the interval between data exceeds 2 seconds, a transmission error will be detected. A frame error completion code (error code: 18) is sent as a response to the high-end device from the Reader Writer.

4.2 Command/Response Format

■ Command

The communication frame consists of command, transmission option, and parameters. The transmission option can only be attached to commands 01 ~ 08.

| Command | Transmission option | Parameter 1 | ... | Parameter n | Terminator |
|---------|---------------------|-------------|-----|-------------|------------|
| | | | | | CR |

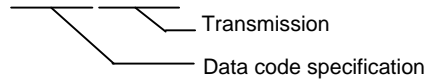

■ Response

The communication frame consists of a completion code, parameters and a terminator.

| Termination code | Parameter 1 | ... | Parameter n | Terminator |
|------------------|-------------|-----|-------------|------------|
| | | | | CR |

(1) Commands

Specifies the process of the Reader Writer. The following commands are available.

| Command Name | Number | Description |
|--------------|--------|--|
| Read | 01 | Reads Tag Memory data in unit of pages |

| | | |
|------------------|----|---|
| Write | 02 | Writes data onto Tag Memory in unit of pages |
| Multiple Write | 03 | Writes the same data onto Tag Memory in unit of pages |
| Byte Write | 04 | Writes data onto Tag Memory in unit of bytes |
| Write Protection | 08 | Specifies setting or releasing write protection per page |
| ACK | 11 | Is sent when High-end device successfully receives data |
| NACK | 12 | Is sent when High-end device does not receive data successfully |
| STOP | 13 | Stops processing of command being executed |
| Oscillation ON | 14 | Activates Oscillation Mode on the Antenna |
| Oscillation Off | 15 | Stops Oscillation Mode on the Antenna |
| Test | 10 | Transmits data received directly back to High-end device |

(2) Transmission Option

Data code and transmission operations are specified by the Transmission Option.

1) Code Specification for Data

When using commands 01 through 08, specify what kind of code communication will be conducted between the high-end unit and the Reader Writer for reading or writing data.

When using the write protection command (08), please specify code as HEX code ("0").

- HEX Code Specification: "0"

Data code within Tag is transformed into a 2-digit hexadecimal upon communication. The types of characters used will be "0" ~ "F," one of the 16 different types.

Ex) When Tag data is 4Fh ("0")

34h ("4") and 46h ("F") are transmitted.

- ASCII Code Specification: "1"

Data code within Tag is communicated as is. However, the control code (CR) 0Dh cannot be used for read or write data.

Ex) When Tag data is 4Fh ("0")

4Fh ("0") is transmitted.

2) Specifying Transmission Operations

Specifies transmission operations when command is one of 01 through 08.

| Option | Number | Details |
|----------------|--------|---|
| Single Trigger | 0 | Conducts transmission with Tag on Single Trigger Mode |
| Single Auto | 1 | Conducts transmission with Tag on Single Auto Mode |
| FIFO Trigger | 8 | Conducts transmission with Tag on FIFO Trigger Mode |
| FIFO Auto | 9 | Conducts transmission with Tag on FIFO Auto Mode |
| FIFO Continue | A | Conducts transmission with Tag on FIFO Continue Mode |
| FIFO Repeat | B | Conducts transmission with Tag on FIFO Repeat Mode |

(3) Completion Code

The Reader Writer will return the response to the high-end unit by transmitting a completion code. The definitions of the completion codes are as follows:

| Class | Completion Code | Name | Details |
|---|-----------------|-----------------------------|--|
| Normal end | 00 | Normal end | Normal operations completed. |
| Communication Error between high-end unit and Reader Writer | 10 | Parity error | * There is a parity error in the command received. |
| | 11 | Framing error | There is a framing error in the command received. |
| | 12 | Overrun error | There is an overrun error in the command received. |
| | 14 | Format error | The command format is not suitable for the specification. Ex) Command section is not defined; page/address specification is incorrect, etc. |
| | 18 | Frame length error | When the receiving frame exceeds 273 characters. When the intervals between the characters being received exceeded 2 sec. |
| Transmission Error between Reader Writer and Tag | 70 | Transmission error | Noise or other disruption occurred during communication with Tag, and the command cannot be executed properly. |
| | 71 | Verification error | Tag is dated or incapable of being written correctly for physical reasons. |
| | 72 | Tag absence error | Tag is not present near antenna at time of Trigger commands execution. |
| | 7A | Address specification error | Page specification is incorrect. |
| | 7B | Outside of write area error | There is a Tag in the area where reading is possible but writing is not. |
| | 7D | Write protection error | Write command was executed on a page specified with write protection. |
| | 7F | ID system error | The Tag used is not to specification of system. |
| Hardware Error | 7C | Antenna hardware error | There is a hardware problem on the antenna. |

4.3 Commands Types and Responses

(1) Read

Read command is used when data is to be read from the Tag. Data for any specified page may be read. The maximum number of pages that may be read at one time is 16.

■ Command

The pages to be read as parameters will be transmitted. Page specifications shall be made by specifying the bit indicating the page as “1” and the other bytes as “0”. This binary is converted to a hexadecimal and transmitted as a command. Pages can be specified at random.

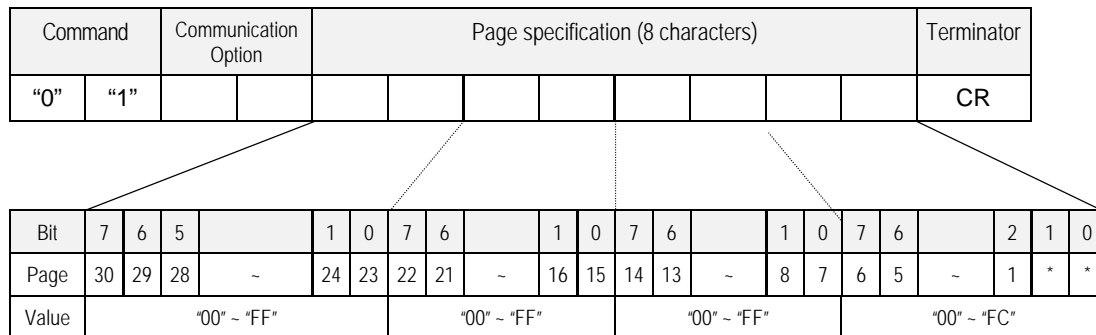

*0,1 bits should be specified as “0”. When “1” is specified, it will be regarded as an error (error code 14).

■ Response

The completion code (“00” when normal) and read data will be transmitted. The read data will be transmitted continuously according to the order of page specification. When an error occurs, the error code is transmitted as a completion code for the reply.

| Completion code | | Read data* | | | | | | Terminator | |
|-----------------|-----|------------|-------|----------|--|--|--|------------|--|
| “0” | “0” | (Data 1) | . . . | (Data n) | | | | CR | |

*Data number n = specified page x 8 (2 characters each in HEX specifications, one character each in ASCII codes.)

<Command Example>

When reading all 6 pages from pages 1, 3, 5 ~ 8 using the single trigger mode with HEX specification:

```
0100000003D4 [CR]
  \ (00000000000000000000000000000001111010100b)
```

(2) Write

The Write command is used when data is to be written onto the Tag Memory in units of pages. Data can be written on any specified page. The maximum number of pages onto which data may be written at one time is 16.

Command

The pages to be written on, as parameters and the data to be written onto each page will be transmitted. Page specifications shall be made by specifying the bit indicating the page as "1" and the other bytes as "0". This binary is converted to a hexadecimal and transmitted as a command. Data to be written should be specified in the order of specification of the designated pages.

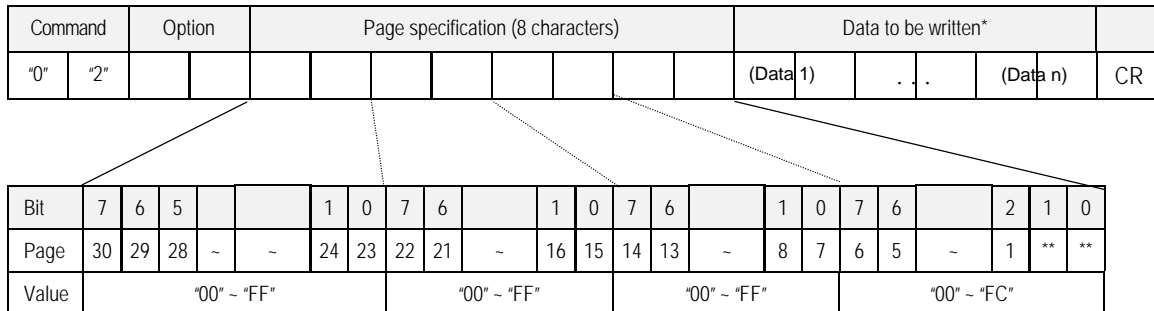

- * Data number n = specified page x 8 (2 characters each in Hex data, one character each in ASCII code)
- ** 0, 1 bits should be specified as "0". When "1" is specified, it will be regarded as an error (error code 14).

Response

The completion code ("00" when successful) will be transmitted.

| Completion code | | Terminator |
|-----------------|-----|------------|
| "0" | "0" | CR |

<Command Example>

When writing 2 pages of data onto pages 8 and 9 using the FIFO repeat mode with ASCII specification:

```
021B00000600 (Data on page 8) (Data on page 9) [CR]
      \ (0000000000000000000011000000000b)
```

(3) Multiple Write

The Multiple Write command is used when the same data is written in units of pages. Pages may be specified at random. There is no limit on the number of pages that may be written at one time.

■ Command

The designated pages to be written as parameters and the data to be written onto each page is transmitted. Page specifications shall be made by specifying the bit indicating the page as "1" and the other bytes as "0". This binary is converted to a hexadecimal and transmitted as a command. Data to be written should be specified in the order of specification of the designated pages.

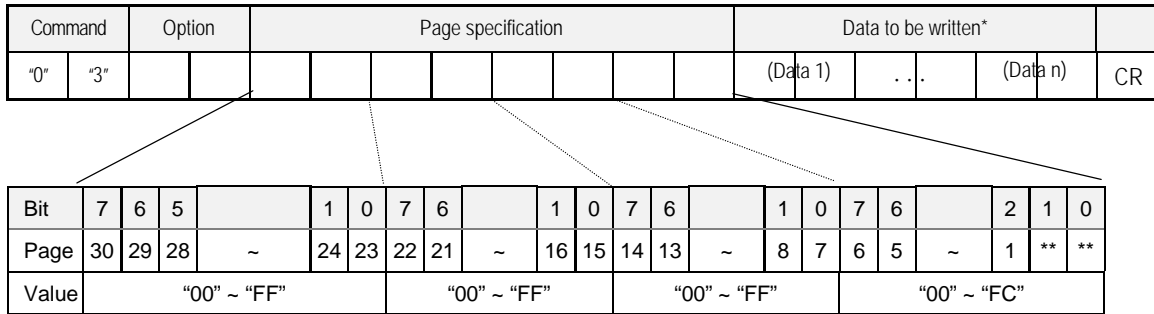

* Data number n = 8 (2 characters each in Hex code, one character each in ASCII code)

** 0, 1 bits should be specified as "0". When "1" is specified, it will be regarded as an error (error code 14).

■ Response

The completion code ("00" when successful) will be transmitted.

| Completion code | | Terminator |
|-----------------|-----|------------|
| "0" | "0" | CR |

(4) Byte Write

The Byte Write command is used when data is to be written onto the Tag in unit of Bytes. Data of any bytes can be written from the specified address. An area spanning over more than one page may be specified, but a maximum limit of 16 pages applies.

■ Command

The area's leading address and the data to be written as parameters will be transmitted. The address may be specified within the range of 00h ~ EFh. The data to be written is to be specified in ascending order from the specified address.

| Command | | Option | | Designated Address | | Data to be written* | | | | | | Terminator |
|---------|-----|--------|--|--------------------|--|---------------------|--|--|---|---|----------|------------|
| "0" | "4" | | | | | (Data 1) | | | . | . | (Data n) | CR |

* Data number n = number of bytes to be written (2 characters each for HEX code, one character each for ASCII code.)

■ Response

The completion code ("00" when normal) will be transmitted.

| Completion code | | Terminator |
|-----------------|-----|------------|
| "0" | "0" | CR |

(5) Write Protection

The Write Protection command is used to set or turn off write protection on Tag.

■ Command

The pages to set or turn off write protection on as parameters will be transmitted. Page specifications shall be made by specifying the bit indicating the page as "1" and the other bytes as "0". This binary is converted to a hexadecimal and transmitted as a command. If set and turn off were specified for the same page, the set command will have priority.

The communication operation that may be specified as options, are 0 (single trigger) and 8 (FIFO trigger).

| Command | Option | Setting specification (8 characters) | | | | | | | | Turn off specification (8 characters) | | | | | | | | | | |
|---------|--------|--------------------------------------|--|--|--|----------|----------|----------|----------|---------------------------------------|----------|----------|----------|--|--|--|--|--|--|----|
| "0" | "8" | | | | | (Data 1) | (Data 2) | (Data 3) | (Data 4) | (Data 1) | (Data 2) | (Data 3) | (Data 4) | | | | | | | CR |

| Bit | 7 | 6 | 5 | | 1 | 0 | 7 | 6 | | 1 | 0 | 7 | 6 | | 1 | 0 | 7 | 6 | | 2 | 1 | 0 |
|-------|-------------|----|----|---|-------------|----|----|----|-------------|----|----|----|-------------|---|---|---|---|---|---|---|---|---|
| Page | 30 | 29 | 28 | ~ | 24 | 23 | 22 | 21 | ~ | 16 | 15 | 14 | 13 | ~ | 8 | 7 | 6 | 5 | ~ | 1 | * | * |
| Value | "00" ~ "FF" | | | | "00" ~ "FF" | | | | "00" ~ "FF" | | | | "00" ~ "FC" | | | | | | | | | |

* 0,1 bytes should be specified as "0". When "1" is specified, it will be regarded as an error (error code 14).

■ Response

The completion code ("00" when normal) and write protection status information will be transmitted.

| Command | Setting specification (8 characters) | | | | | | | | | |
|---------|--------------------------------------|----------|----------|----------|----------|--|--|--|--|----|
| "0" | "0" | (Data 1) | (Data 2) | (Data 3) | (Data 4) | | | | | CR |

| Bit | 7 | 6 | 5 | | 1 | 0 | 7 | 6 | | 1 | 0 | 7 | 6 | | 1 | 0 | 7 | 6 | | 2 | 1 | 0 |
|-------|-------------|----|----|---|-------------|----|----|----|-------------|----|----|----|-------------|---|---|---|---|---|---|---|---|---|
| Page | 30 | 29 | 28 | ~ | 24 | 23 | 22 | 21 | ~ | 16 | 15 | 14 | 13 | ~ | 8 | 7 | 6 | 5 | ~ | 1 | * | * |
| Value | "00" ~ "FF" | | | | "00" ~ "FF" | | | | "00" ~ "FF" | | | | "00" ~ "FC" | | | | | | | | | |

* 0, 1 bits are indicated as "0".

(6) ACK

ACK is transmitted after receiving the response during FIFO Continue operation, and it allows reading of the following:

■ Command

| Command | | Terminator |
|---------|-----|------------|
| "1" | "1" | CR |

■ Response

There is no response.

(7) NACK

When the High-end device was not able to receive a response correctly, NACK is transmitted to demand the response to be transmitted again. When the Reader Writer receives this command, the most recent response will be transmitted again.

■ Command

| Command | | Terminator |
|---------|-----|------------|
| "1" | "2" | CR |

■ Response

The most recent response will be transmitted again.

(8) STOP

The STOP command is used to stop the Reader Writer executing a command. When the Reader Writer receives this command, it immediately stops the execution of the current command and sets on stand by mode for a new command.

■ Command

| Command | | Terminator |
|---------|-----|------------|
| "1" | "3" | CR |

■ Response

| Completion Code | | Terminator |
|-----------------|-----|------------|
| "0" | "0" | CR |

(9) Oscillation ON / OFF

The Oscillation ON / OFF command specifies the oscillation of the antenna.

■ Command

Oscillation ON

| Command | | Terminator |
|---------|-----|------------|
| "1" | "4" | CR |

Oscillation OFF

| Command | | Terminator |
|---------|-----|------------|
| "1" | "5" | CR |

■ Response

| Completion Code | | Terminator |
|-----------------|-----|------------|
| "0" | "0" | CR |

(10) Test

The Test command is to conduct transmission tests on the communication to the High-end device. When the Reader Writer receives this command, it transmits the same command to the High-end device.

■ Command

| Command | | Test Data | | | | Terminator |
|---------|-----|-----------|-----|----------|--|------------|
| "1" | "0" | (Data 1) | ... | (Data n) | | CR |

■ Response

| Completion code | | Test Data (Same data as the command) | | | | Terminator |
|-----------------|-----|--------------------------------------|-----|----------|--|------------|
| "0" | "0" | (Data 1) | ... | (Data n) | | CR |

5. Transmission Specification (Reference Values)

5.1 Transmission Distance

The transmission distance specifications are as follows. Please take note that transmission distance is subject to change, depending on installation requirements. Please refer to "6. The Influence of Requirements of Use on Transmission Distance."

| Tag | | Transmission Distance |
|-------------------|-----------|-----------------------|
| Model V700-D13P31 | Still | 8 ~ 43 mm |
| | In motion | 20 ~ 43 mm |
| Model V700-D13P21 | Still | 8 ~ 43 mm |
| | In motion | 20 ~ 43 mm |

- Note**
1. The read distance and write distance are the same
 2. The values indicated above are based on the assumption that there is no axis variation.

5.2 Transmission Area

- Reader Writer: Model V700-HMD11
- Tag: Model V700-D13P31 / Model V700-D13P21

The transmission area diagram going through the center of the antenna and indicated on a flat surface vertical to the antenna surface is as indicated below. Read / write are the same area.

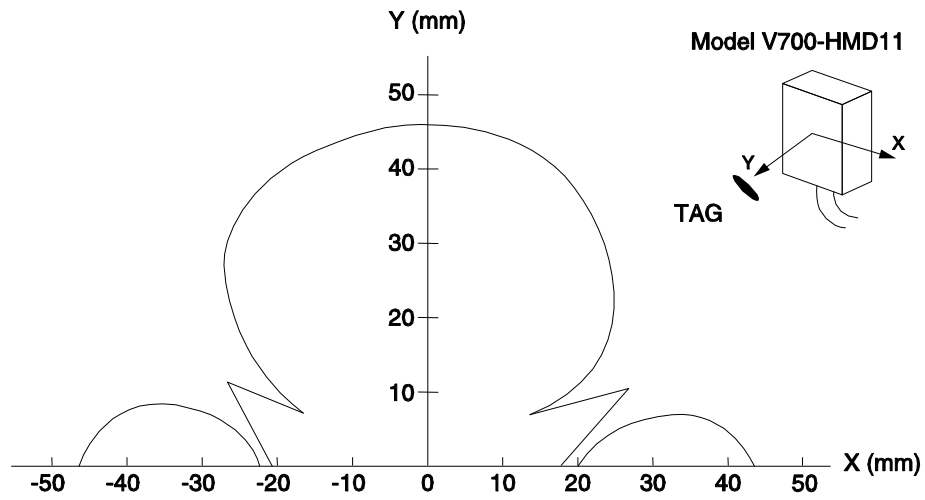

5.3 Communication Time

The Model V700 Series has two communication times: the transmission time and the TAT (Turn Around Time).

(1) Transmission Time

This is the transmission processing time between the Reader Writer and the Tags. This time varies in accordance with the number of pages to be read / written.

The transmission time values are as indicated below. This value is estimated based on the assumption that the transmission operation is on trigger mode and that there is no interference in transmission due to noise and other causes.

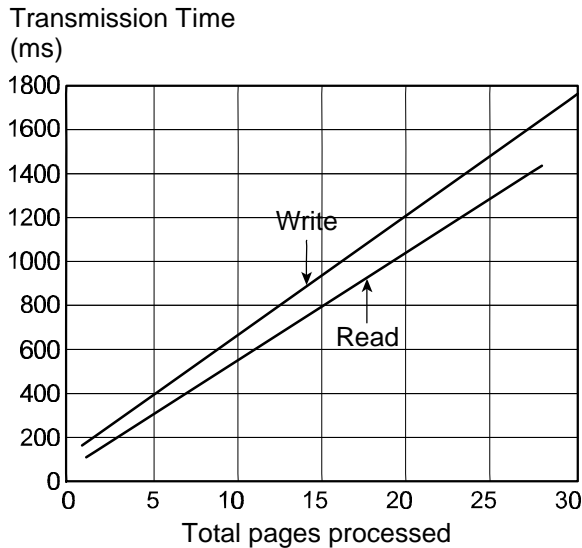

Transmission Time Calculation Formula

| | Transmission Time (msec) |
|-------|--------------------------|
| Read | T=48N+66 |
| Write | T=55N+120 |

N: pages to be processed

(2) TAT

This is the time required for the high-end unit to transmit a command to the Reader Writer, and to complete receipt of a response. This time varies in accordance with the transmission speed and the communication control mode.

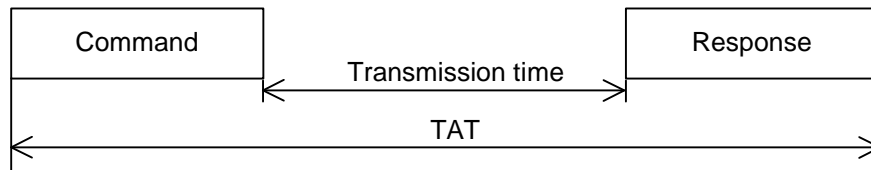

<Example of TAT Calculation>

- Read 1 page

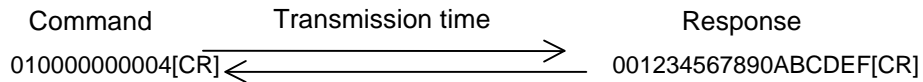

$$\frac{1}{9600}(\text{sec}) \times 11(\text{bits}) \times 13(\text{characters}) + 114(\text{msec}) + \frac{1}{9600}(\text{sec}) \times 11(\text{bits}) \times 19(\text{characters}) = 151(\text{msec})$$

(bit time)
(number of bits per character)
(number of characters transmitted)

- 〔 Prerequisites: 1 HEX code specification
2 No spaces between characters; all data sent consecutively 〕

6. The Influence of Requirements of Use on Transmission Distance (Reference Values)

When using the Reader Writer, transmission distance varies in accordance with the requirements of use (the existence / non-existence of metal objects in the vicinity, the use /non-use of multiple Reader Writer, power voltage value, etc.). This section indicates how such requirements and changes in them affect communication distance. Please use the following figures for your reference. Note that all values indicated in this section are reference.

6.1 Influence of Metal Objects Surroundings and Metal Objects Behind the Device

When metal objects are around or behind the Reader Writer, transmission distance deteriorates. Please take note of the distance between the metal objects and the Reader Writer as per below when using the Reader Writer.

When the metal object is steel, the relationship between the distance of the metal objects around and behind the Model V700-HMC71 from the device and the transmission distance (read / write) is indicated below. The following values were obtained by using Tags Model V700-D13P31 / Model V700-D13P21 with an axis variation of +- 0 mm.

■ Surrounding Metal Objects

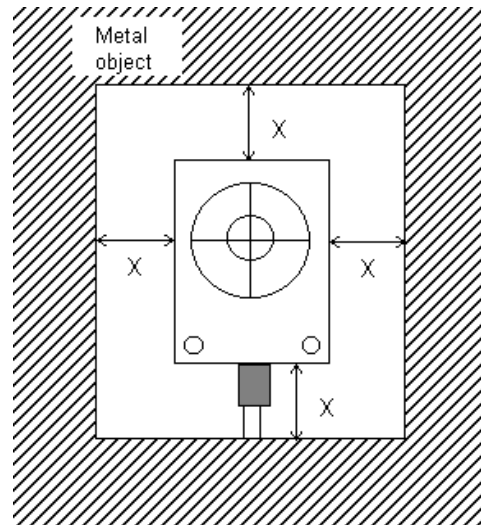
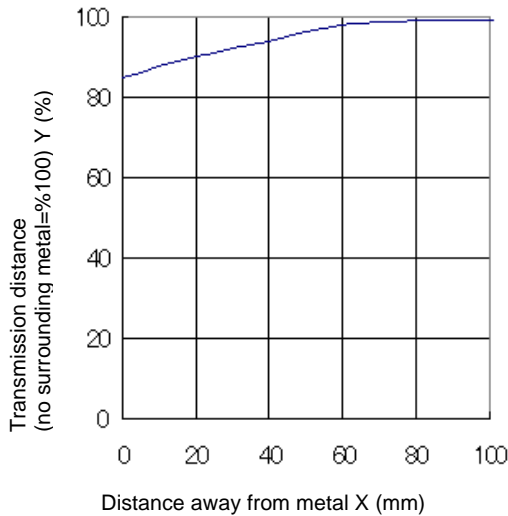

■ Metal Objects behind Reader Writer

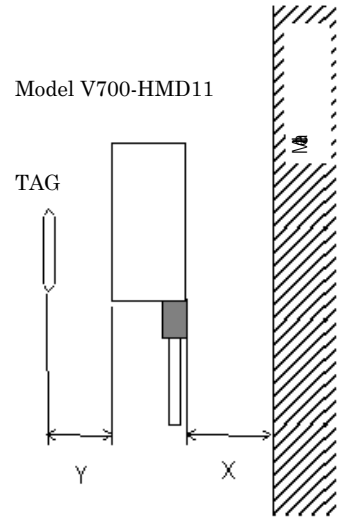
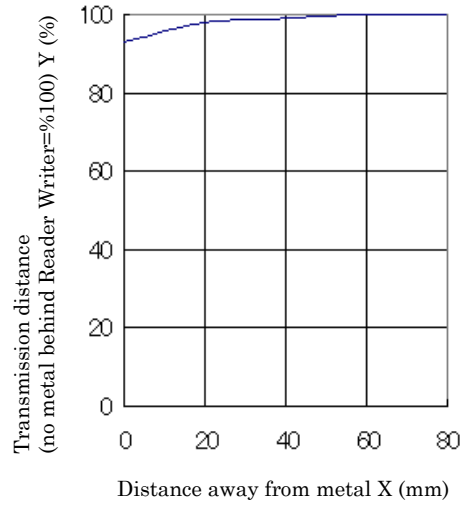

6.2 Mutual Interference between Reader Writers

When using more than one Reader Writer, to prevent erroneous operations due to interference from other Reader Writers, please be sure to check that the below-indicated distance between Reader Writers is secured.

■ When Using Multiple Reader Writers in a Line

410mm or more

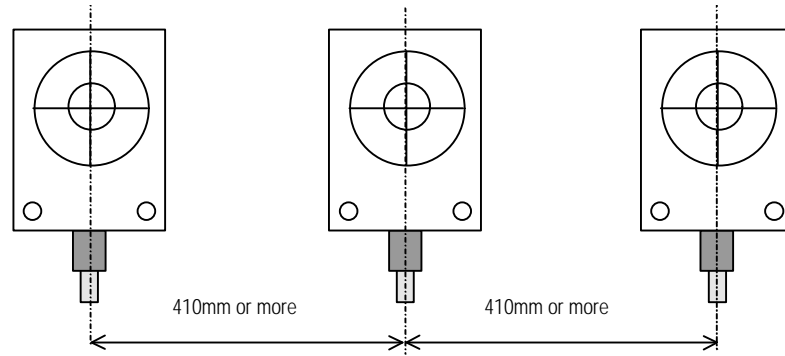

■ When Using the Reader Writers Facing Each Other

460mm or more

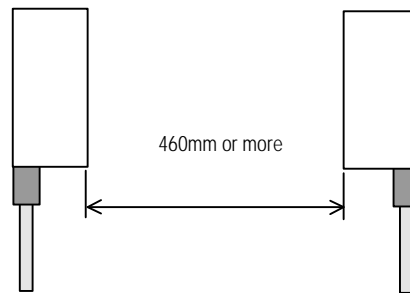

6.3 Effects of Antenna Angle

Please install the Reader Writer and Tags so that they are parallel to each other whenever possible. The Reader Writer and Tags can communicate when installed on angles, but the transmission distance will be shorter. The relationship between angles and transmission distance is as indicated below. The following values were obtained by using Tags Model V700-D13P31 / Model V700-D13P21.

Model V700-HMD11

TAG

Transmission Distance (The distance when angle is 0 degrees is indicated as 100%)

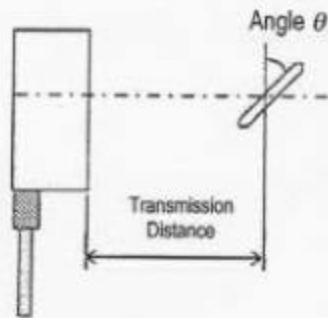

| | Angle of Tag θ (degrees) | | |
|------------------|---------------------------------|-----|-----|
| | 0 | 30 | 45 |
| Model V700-HMD11 | 100% | 85% | 70% |

Appendix 1 Document Revision History

| Date | Modification Contents |
|------------|---|
| Oct., 1998 | First Edition |
| July 2000 | "Applicable Standards" is added on the page 2 |