

Radio Test Report: 99493832 (part 2 of 2)

Applicant: Samsung Electro-Mechanics Co., LTD.
314, Maetan 3-Dong, Yeongtong-Gu
Suwon City, Gyunggi-Do
Korea

Equipment Under Test: SWL-2610U Direct Sequence Spread Spectrum
(E.U.T.) Transceiver

FCC ID: E2XSWL-2610U

In Accordance With: **FCC Part 15, Subpart C (10-1-03 Edition)**
Direct Sequence Transmitters
2400 - 2483.5 MHz (IEEE 802.11g mode)

Tested By: Telefication bv
Edisonstraat 12a
6902 PK Zevenaar

Authorized By: J.P. van de Poll
Co-ordinator Test Group



Date: 26 May 2004

Total Number of Pages: 43

EQUIPMENT: SWL-2610U Spread Spectrum Direct Sequence Transceiver
FCC ID: E2XSWL-2610U

Table of Contents

Section 1	Summary of Test Results	3
Section 2	Equipment Under Test (E.U.T.).....	5
Section 3	Powerline conducted emissions	9
Section 4	Minimum 6 dB bandwidth	12
Section 5	Peak Power Output	16
Section 6	Peak power spectral density	17
Section 7	Spurious Emissions (radiated)	21
Section 8	Spurious Emissions (restricted bands, radiated).....	28
Section 9	Photographs	33
Section 10	Test equipment List.....	38
ANNEX A	TEST METHODOLOGIES.....	39
ANNEX B	CROSS REFERENCE TABLE RSS-FCC.....	42

EQUIPMENT: SWL-2610U Spread Spectrum Direct Sequence Transceiver
FCC ID: E2XSWL-2610U

Summary Of Test Data

NAME OF TEST	PARA. NO.	SPEC.	MEAS.	RESULT
Power line conducted emissions	15.207(a)	66.1 dB μ V	51.9 dB μ V	Complies
Minimum 6 dB bandwidth	15.247(a)(2)	500 kHz	16.4 MHz	Complies
Maximum Peak Power Output	15.247(b)(3)	36 dBm E.I.R.P.	14.9 dBm E.I.R.P.	Complies
Peak Power Spectral Density	15.247(d)	8 dBm/3 kHz	-13.8 dBm/3 kHz	Complies
Spurious Emissions (Radiated)	15.247(c)	> 20 dB below fundamental	> 20 dB	Complies
Restricted band edge emission levels (radiated)	15.205(a)	\leq 54 dB μ V/m (av) \leq 74 dB μ V/m (pk)	54 dB μ V/m (av) 62 dB μ V/m (pk)	Complies

Test Conditions:

Indoor Temperature: 22 °C
 Humidity: 45 %

Test tool Intersil Engineering cTxRx version 2.1.0.0
 Power setting: 145 (adjusted to 130 for channel 1 restricted
 band edge test only)

EQUIPMENT: SWL-2610U Spread Spectrum Direct Sequence Transceiver
FCC ID: E2XSWL-2610U

Section 2 Equipment Under Test (E.U.T.)

General Equipment Information

Equipment class	Part 15 spread spectrum transmitter
Type of equipment	Wireless data transmission equipment in the 2.4 GHz ISM band using spread spectrum techniques
Frequency Range:	2412 – 2462 MHz
Number of Channels:	11
Emissions Designator:	22M0G1D
Standard:	IEEE 802.11g

EQUIPMENT: SWL-2610U Spread Spectrum Direct Sequence Transceiver
FCC ID: E2XSWL-2610U

Description of Modification for Modification Filing

Not applicable

Family List Rationale

Not applicable

EQUIPMENT: SWL-2610U Spread Spectrum Direct Sequence Transceiver
FCC ID: E2XSWL-2610U

Theory of Operation

1. Transmitter Path

Data bits coming from the USB Host interface(1) are processed by the Base Band Processor MAC (BBP/MAC), GW3887(2) on IEEE 802.11g turbo protocol level, IQ modulated and then converted to 2.4 GHz RF signal by Direct up/down converter ISL3686(3).

The ISL3686(3) operating frequency is generated by the ISL3084 VCO(4) divided by two. The 2.4GHz RF signal is then amplified by RF Power Amplifier ISL3980 (5) and then finally emitted via the antenna (6).

2. Receiver path

The 2.4 GHz RF signal comes in via antenna (6) and low noise amplifier (part of ISL3686) (3) to the Direct up/down converter ISL3686 (4) where it is converted to RX IQ signals.

The ISL3686 (3) operating frequency is generated by the ISL3084 VCO (4) divided by two. These IQ signals are converted into data bits by the Base Band Processor MAC (BBP/MAC) GW3887 (2).

The data bits are processed by the Base Band Processor MAC (BBP/MAC) GW3887 (2) on IEEE 802.11g Turbo protocol level. This MAC controller also provides the USB interface to the Host (1).

EQUIPMENT: SWL-2610U Spread Spectrum Direct Sequence Transceiver
FCC ID: E2XSWL-2610U

Block diagram

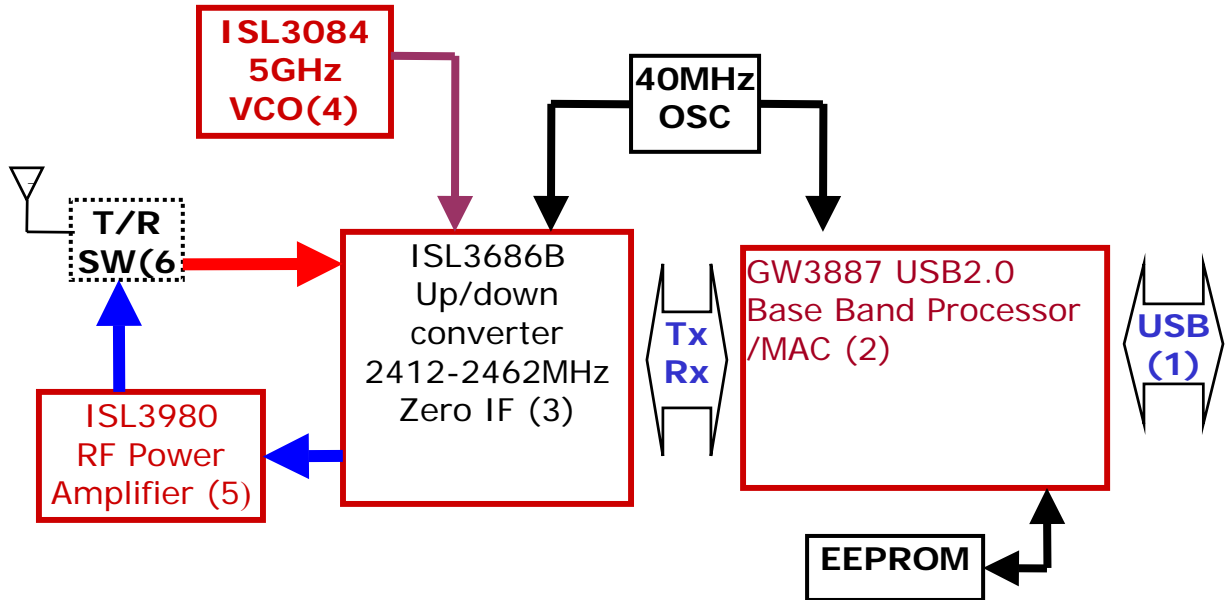

EQUIPMENT: SWL-2610U Spread Spectrum Direct Sequence Transceiver
FCC ID: E2XSWL-2610U

Section 3 Powerline conducted emissions

Test Results: Complies.

Measurement Data: See attached tables

Equipment used: MEDION[®] notebook computer model MD 40100 with AC adaptor model FSP120-A AC manufactured by FSP GROUP Inc.

EQUIPMENT: SWL-2610U Spread Spectrum Direct Sequence Transceiver
FCC ID: E2XSWL-2610U

Neutral to ground

Date: 24-05-2004						
Signal measured on "Neutral".						
Measurement =>	QPeak			Av		
Frequency	Level	Limit	Frequency	Level	Limit	
(MHz)	dB	dB	(MHz)	dB	dB	
Range	(uV)	(uV)		(uV)	(uV)	
01	0.15000	50.2	66.1	0.16300	44.6	55.4
02	0.24230	45.6	62.1	0.24230	39.4	52.1
03	0.24940	45.1	61.8	0.24940	37.6	51.8
04	0.40720	47.4	57.8	0.40720	40.0	47.8
05	0.56760	43.5	56	0.56760	30.6	46
06	0.57580	44.0	56	0.57580	35.1	46
07	0.81150	44.1	56	0.81830	33.8	46
08	0.98390	41.2	56	0.98390	30.1	46
09	1.31100	42.7	56	1.32080	30.0	46
10	1.64620	40.5	56	1.63060	27.8	46
11	2.20690	39.6	56	2.19210	26.8	46
12	2.85070	37.5	56	2.86390	23.9	46
13	4.33870	39.4	56	4.33870	28.3	46
14	4.70170	35.4	56	4.70170	25.4	46
15	7.35480	29.7	60	7.35480	19.3	50
16	10.0998	33.0	60	10.1886	23.7	50
17	12.6024	34.5	60	12.9034	26.4	50
18	13.6108	31.2	60	13.5948	23.1	50
19	Below	30.0	60	Below	30.0	50
20	Below	30.0	60	Below	30.0	50

This product is in compliance with FCC part 15, subpart C, paragraph 15.207(a)

* ==> exceeding the limit

The frequency range 0.15 - 30 MHz is divided into 20 subranges. For every subrange the highest emission component is given in the table.

In ranges marked "Below" the maximum level of the components measured, is below 30 dBuV. For this evaluation, peak detection is used.

EQUIPMENT: SWL-2610U Spread Spectrum Direct Sequence Transceiver
FCC ID: E2XSWL-2610U

Phase to ground

Time: 15:12:42		Date: 24-05-2004				
Signal measured on "Life".						
Measurement =>	QPeak			Av		
Frequency	Level	Limit	Frequency	Level	Limit	
(MHz)	dB	dB	(MHz)	dB	dB	
Range	(uV)	(uV)		(uV)	(uV)	

01	0.15000	51.9	66.1	0.16120	38.9	55.5
02	0.25330	40.2	61.7	0.24090	28.3	52.1
03	0.32480	44.7	59.6	0.32480	37.7	49.6
04	0.32780	44.8	59.6	0.32780	39.5	49.6
05	0.48680	39.5	56.3	0.48880	28.9	46.2
06	0.65560	44.0	56	0.65400	34.3	46
07	0.73150	38.6	56	0.73710	28.4	46
08	0.98950	36.4	56	0.98010	23.6	46
09	1.32080	37.9	56	1.32080	24.3	46
10	1.98700	36.0	56	1.97400	23.6	46
11	2.64510	36.0	56	2.63690	22.6	46
12	3.50490	39.0	56	3.50490	26.5	46
13	3.96710	41.1	56	3.97570	29.3	46
14	5.85190	31.5	60	5.85190	21.8	50
15	6.20260	30.1	60	6.21120	21.1	50
16	9.07960	29.3	60	8.75140	19.6	50
17	12.8936	33.8	60	12.9490	25.7	50
18	13.5680	32.0	60	13.5986	24.0	50
19	19.0906	26.4	60	19.0906	18.7	50
20	23.5946	22.3	60	23.5946	13.8	50

This product is in compliance with FCC part 15, subpart C, paragraph 15.207(a)						
* ==> exceeding the limit						
The frequency range 0.15 - 30 MHz is divided into 20 subranges. For every subrange the highest emission component is given in the table.						
In ranges marked "Below" the maximum level of the components measured, is below 30 dBuV. For this evaluation, peak detection is used.						

EQUIPMENT: SWL-2610U Spread Spectrum Direct Sequence Transceiver
FCC ID: E2XSWL-2610U

Section 4 Minimum 6 dB bandwidth

NAME OF TEST: Occupied Bandwidth

PARA. NO.: 15.247(a)(2)

Test Results:

Complies. The 6 dB bandwidth is:

Channel 1	Channel 6	Channel 11
16.44 MHz	16.44 MHz	16.48 MHz

Measurement Data:

See attached graphs

EQUIPMENT: SWL-2610U Spread Spectrum Direct Sequence Transceiver
FCC ID: E2XSWL-2610U

Channel 1

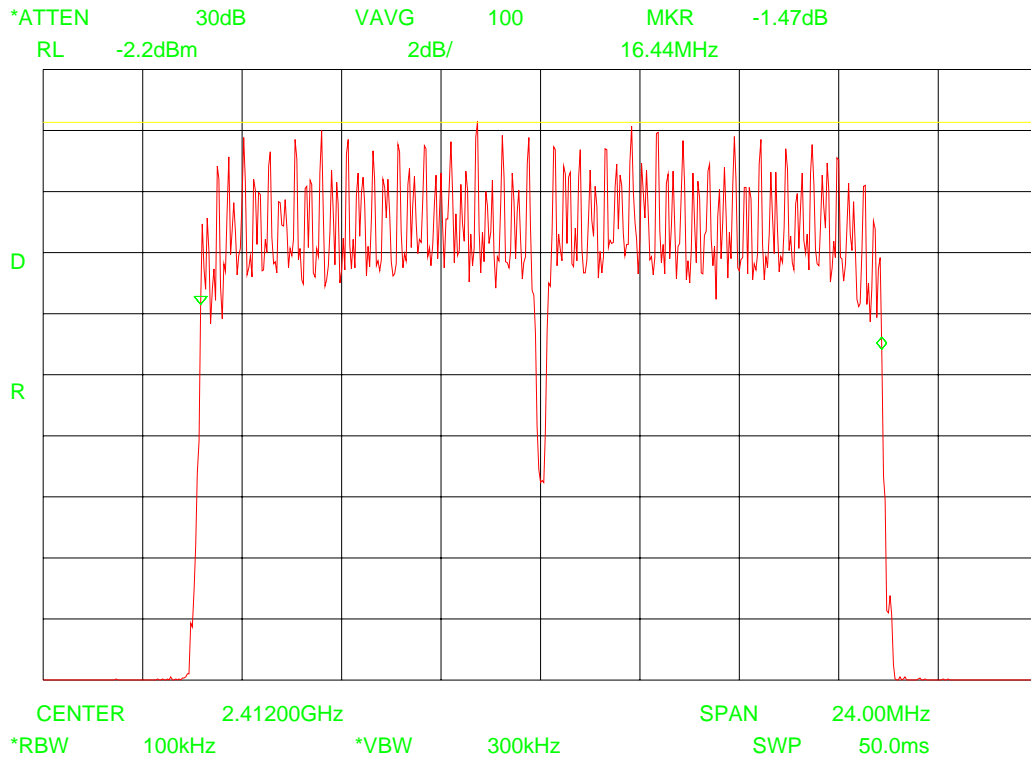

EQUIPMENT: SWL-2610U Spread Spectrum Direct Sequence Transceiver
FCC ID: E2XSWL-2610U

Channel 6

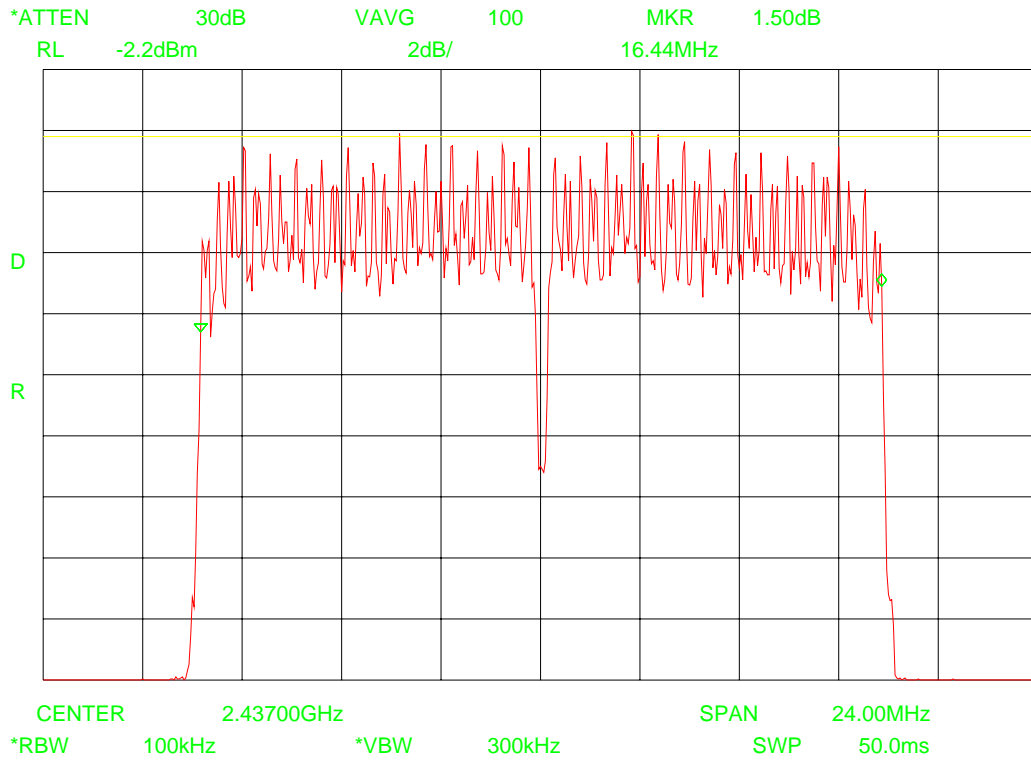

EQUIPMENT: SWL-2610U Spread Spectrum Direct Sequence Transceiver
FCC ID: E2XSWL-2610U

Channel 11

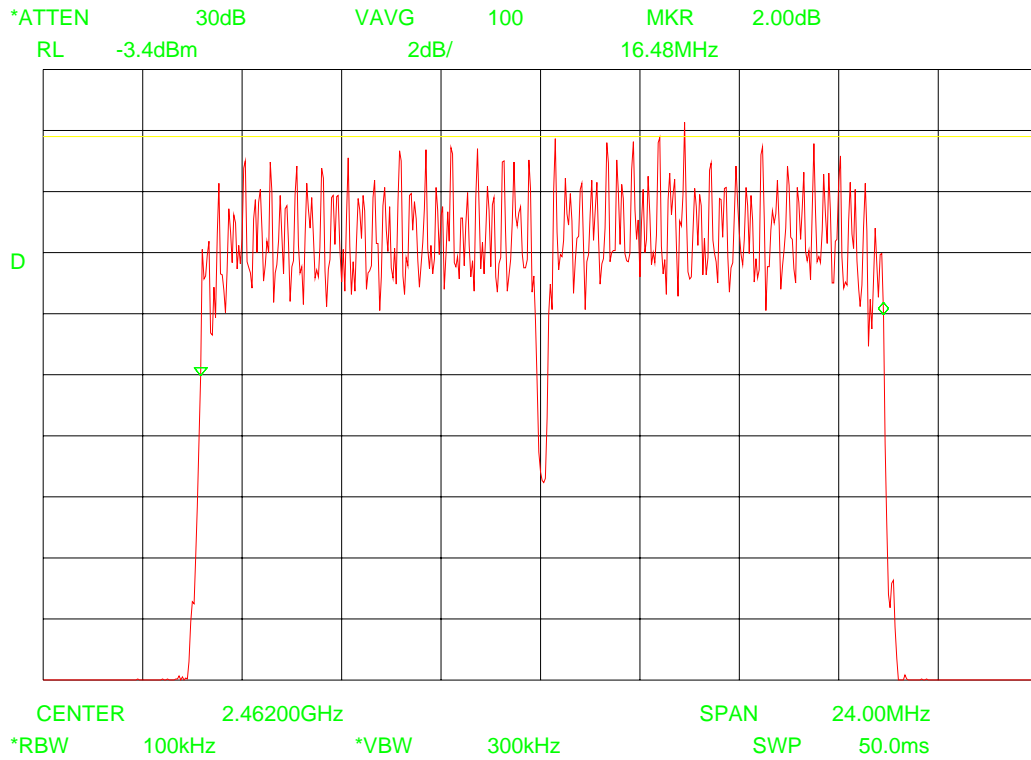

EQUIPMENT: SWL-2610U Spread Spectrum Direct Sequence Transceiver
FCC ID: E2XSWL-2610U

Section 5 Peak Power Output

NAME OF TEST: Peak Power Output	PARA. NO.: 15.247 (b) (3)
---------------------------------	---------------------------

Test Results: Complies. The maximum peak power output of the transmitter is:

Channel 1	Channel 6	Channel 11
13.7 dBm E.I.R.P.	14.2 dBm E.I.R.P	14.9 .dBm E.I.R.P

Measurement Data: Detachable antenna? Yes No
 If yes, state the type of non-standard connector used at the antenna port:

Directional Gain of Antenna: 2.0 dBi or 1.58 Numeric.
 Peak Power Output: 30.9 mWatts.
 Field Strength: 110.1 dBμV/m @ 3m or 0.316 V/m @ 3m.

Antennas: Not applicable

Note: Tests are performed with integral antenna.

EQUIPMENT: SWL-2610U Spread Spectrum Direct Sequence Transceiver
FCC ID: E2XSWL-2610U

Section 6 Peak power spectral density

NAME OF TEST: Peak power spectral density

PARA. NO.: 15.247 (d)

Test results:

Complies.

Channel 1	Channel 6	Channel 11
-16.43 dBm	-13.93 dBm	-13.77 dBm

Measurement data:

see attached plots

EQUIPMENT: SWL-2610U Spread Spectrum Direct Sequence Transceiver
FCC ID: E2XSWL-2610U

Channel 1

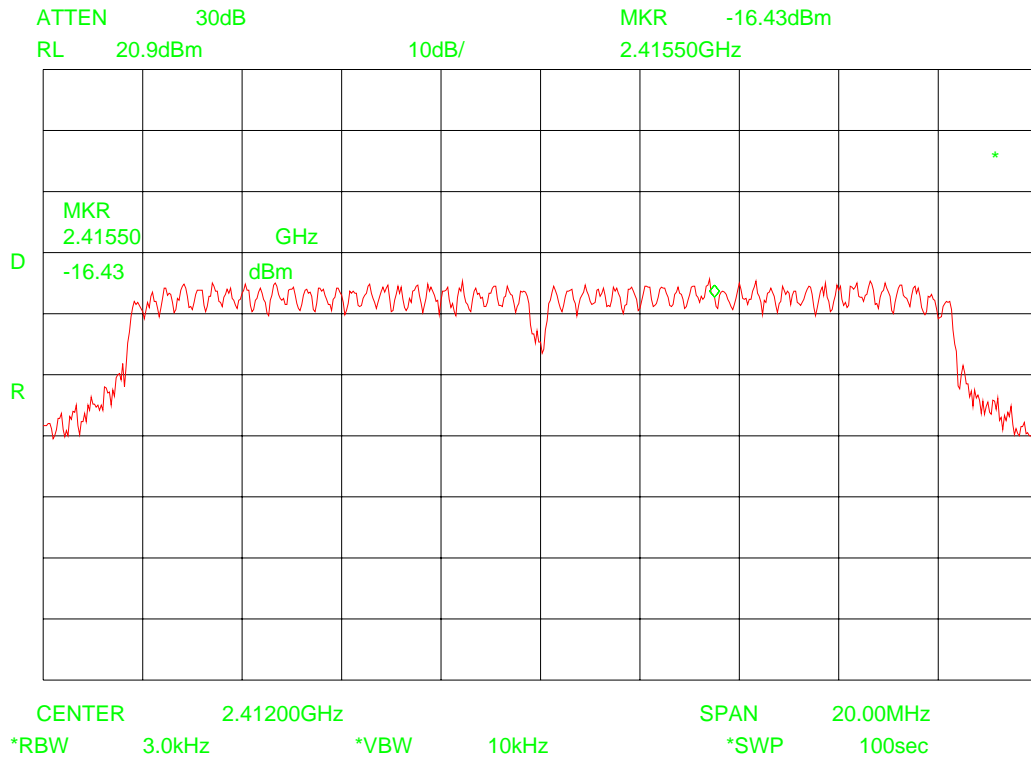

EQUIPMENT: SWL-2610U Spread Spectrum Direct Sequence Transceiver
FCC ID: E2XSWL-2610U

Channel 6

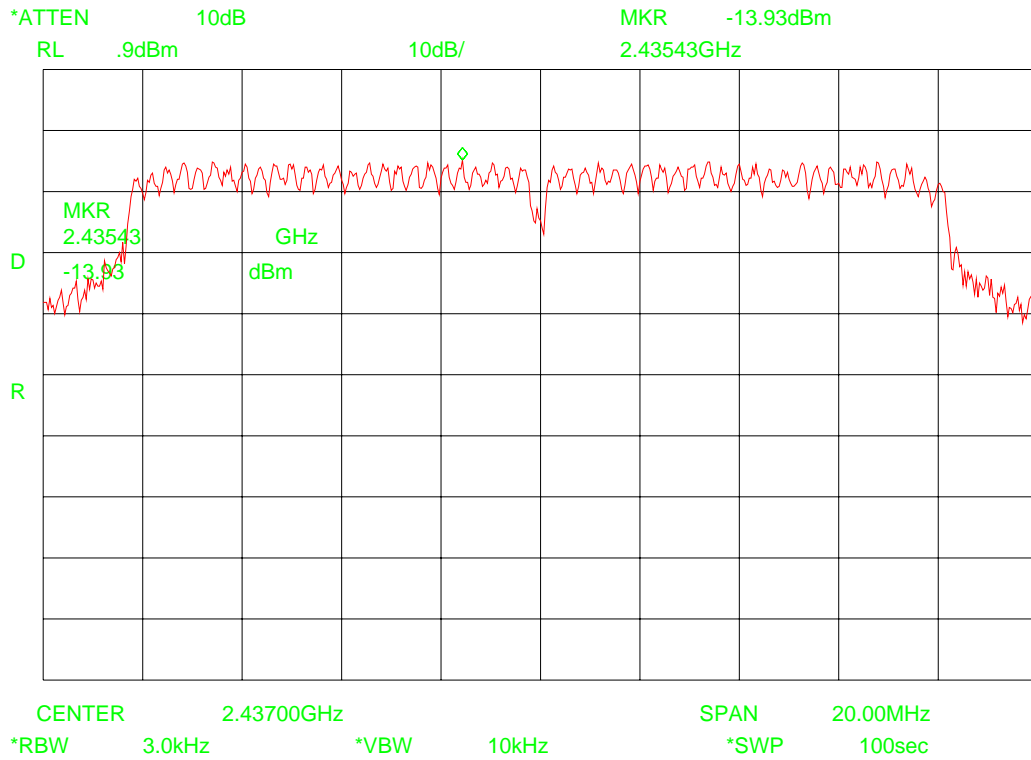

EQUIPMENT: SWL-2610U Spread Spectrum Direct Sequence Transceiver
FCC ID: E2XSWL-2610U

Channel 11

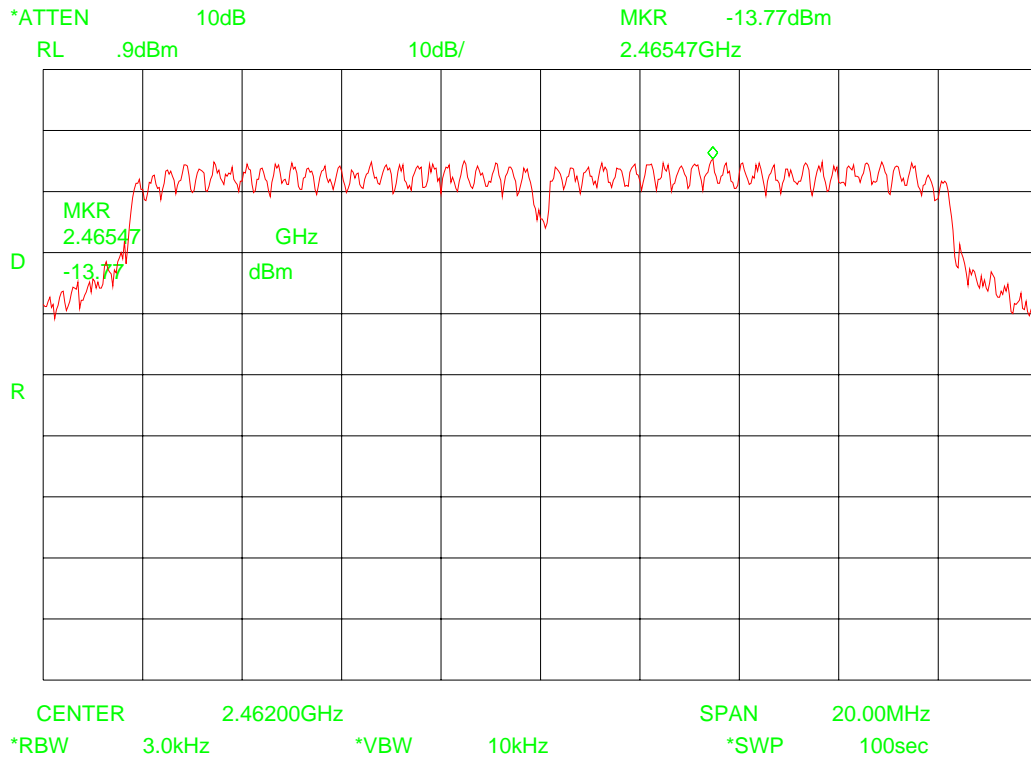

EQUIPMENT: SWL-2610U Spread Spectrum Direct Sequence Transceiver
FCC ID: E2XSWL-2610U

Section 7 Spurious Emissions (radiated)

NAME OF TEST: Spurious Emissions (Radiated)	PARA. NO.: 15.247(c)
---	----------------------

Test Results:

Complies

Spurious emissions in the frequency band 30 – 1000 MHz have proven to be radiated by the host equipment.

This phenomenon was verified on the following Open Area Test Site:

TNO Electronic Products & Services (EPS) B.V
Smidshornerweg 18
9822 TL Niekerk
The Netherlands

FCC listed : 90828
Industry Canada : IC3501

Measurement Data:

See attached graphs.

Note:

The graphs represent effective radiated power (erp) values for frequencies below 1 GHz and equivalent isotropic radiated power (eirp) values for frequencies above 1 GHz.

EQUIPMENT: SWL-2610U Spread Spectrum Direct Sequence Transceiver
 FCC ID: E2XSWL-2610U

CH 1: horizontal polarization

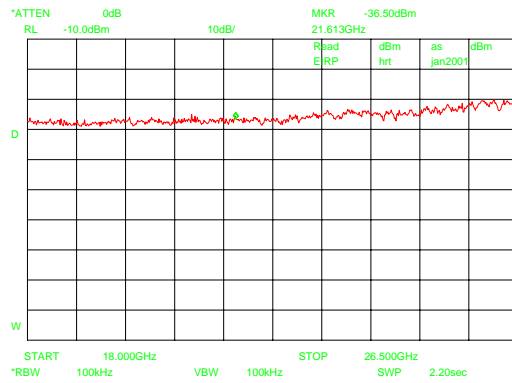
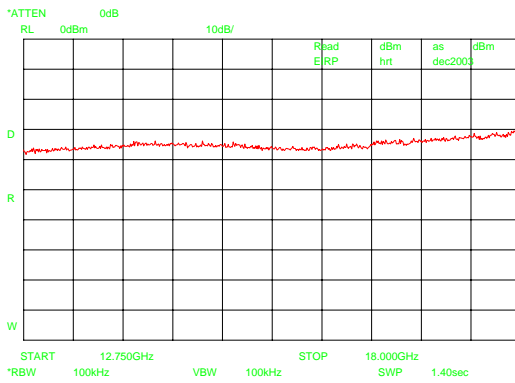
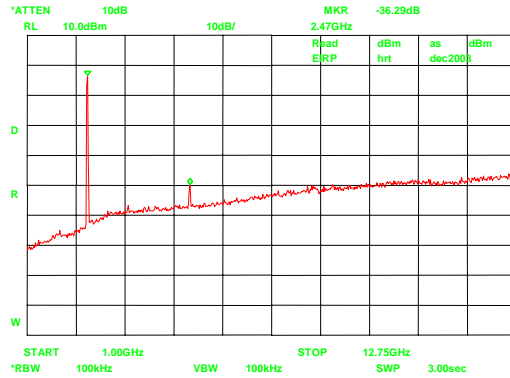
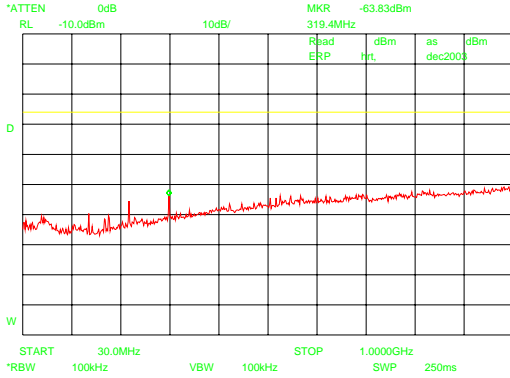

EQUIPMENT: SWL-2610U Spread Spectrum Direct Sequence Transceiver
FCC ID: E2XSWL-2610U

CH 1: vertical polarization

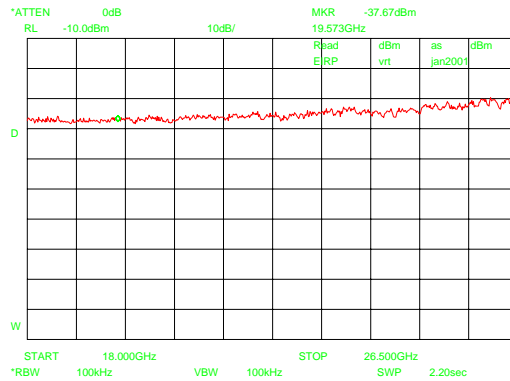
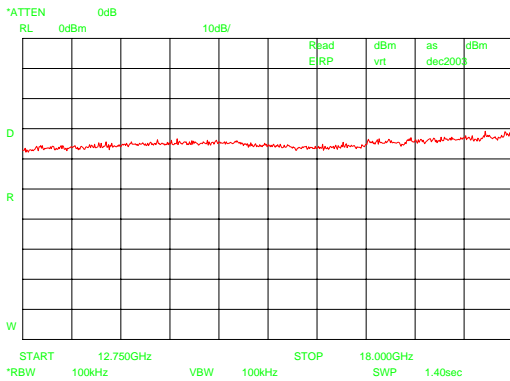
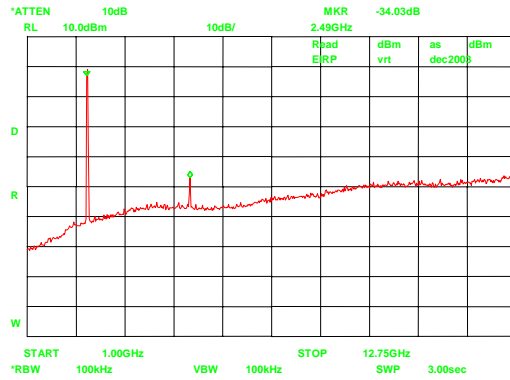
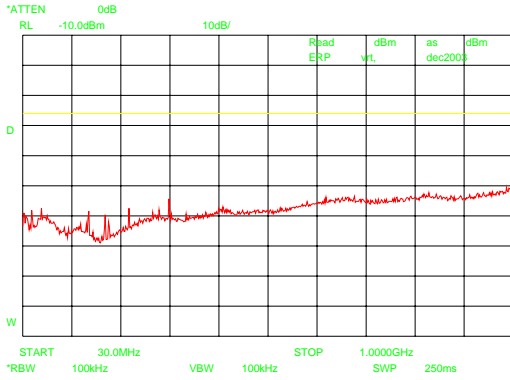

EQUIPMENT: SWL-2610U Spread Spectrum Direct Sequence Transceiver
FCC ID: E2XSWL-2610U

CH 6: horizontal polarization

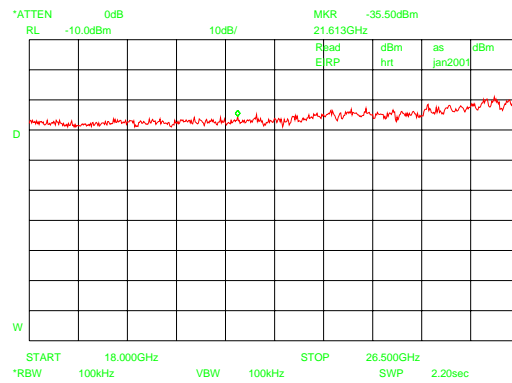
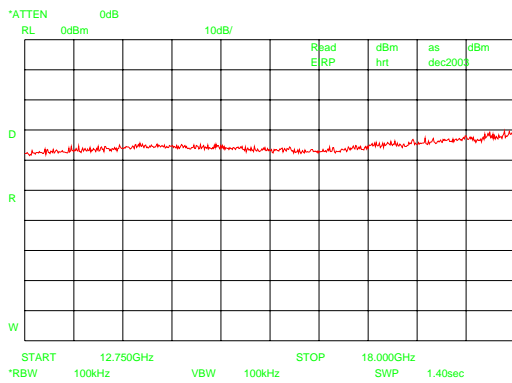
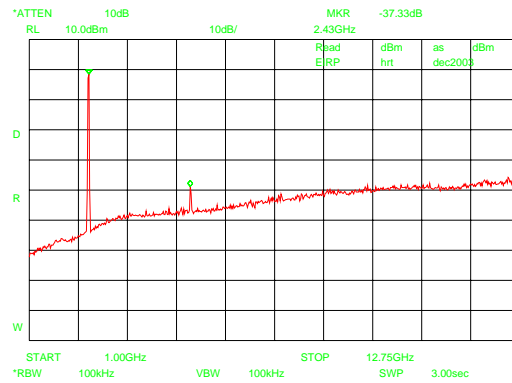
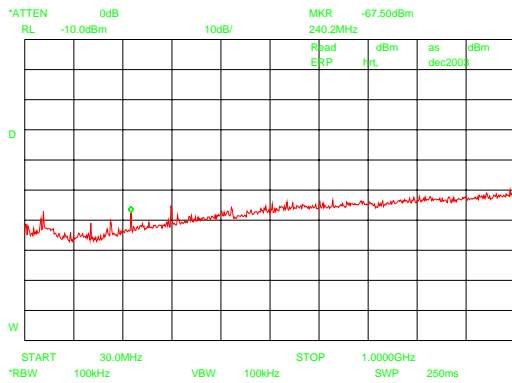

EQUIPMENT: SWL-2610U Spread Spectrum Direct Sequence Transceiver
FCC ID: E2XSWL-2610U

CH 6: vertical polarization

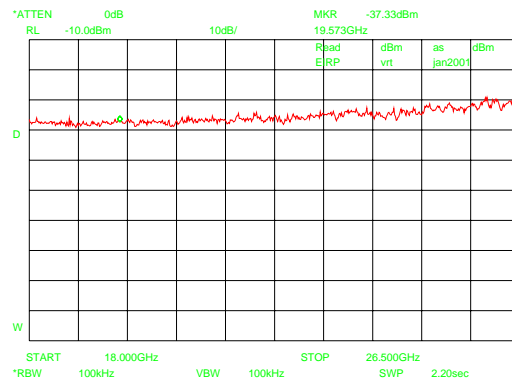
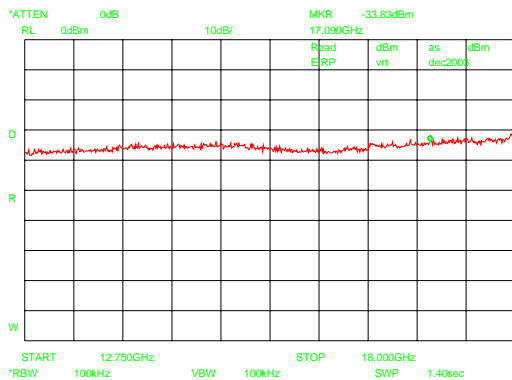
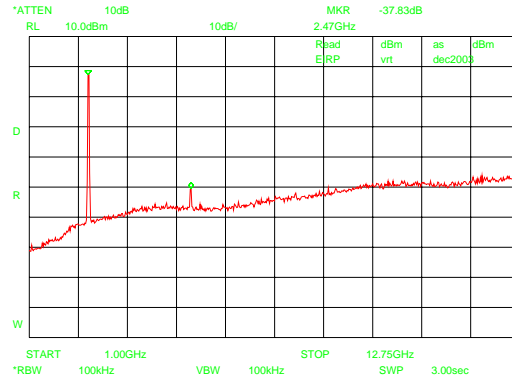
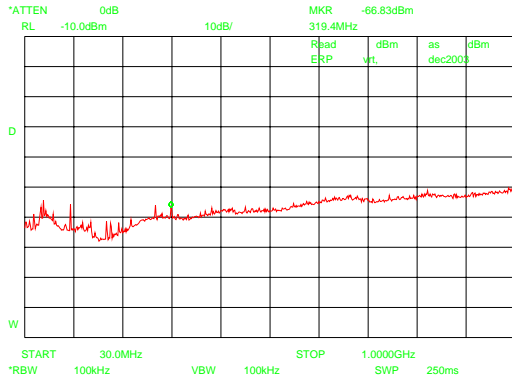

EQUIPMENT: SWL-2610U Spread Spectrum Direct Sequence Transceiver
FCC ID: E2XSWL-2610U

CH 11: horizontal polarization

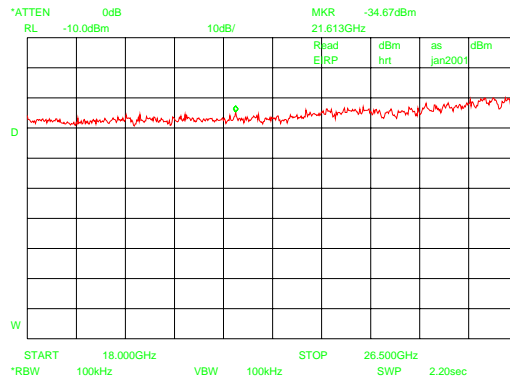
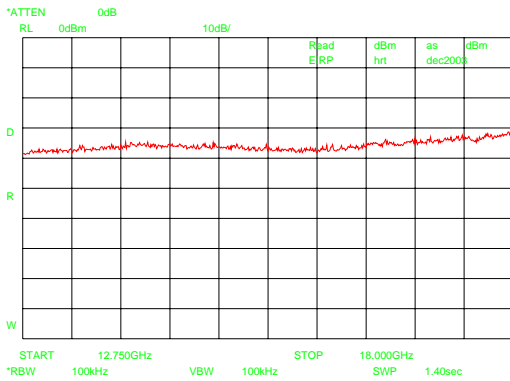
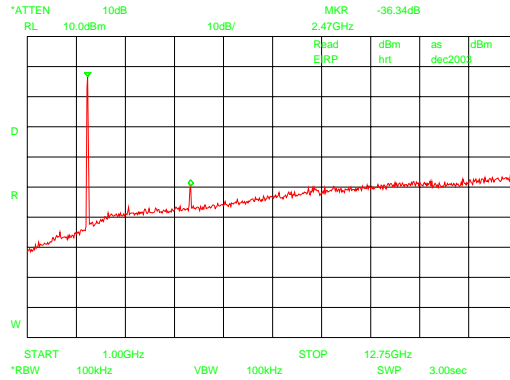
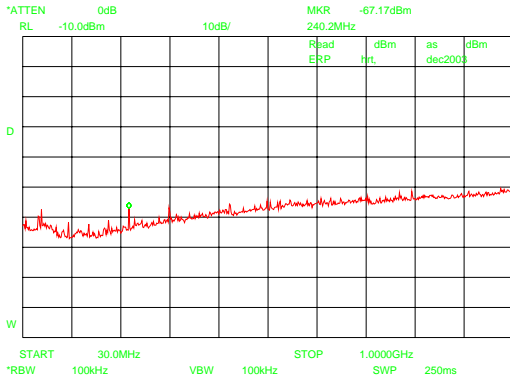

EQUIPMENT: SWL-2610U Spread Spectrum Direct Sequence Transceiver
FCC ID: E2XSWL-2610U

CH 11: vertical polarization

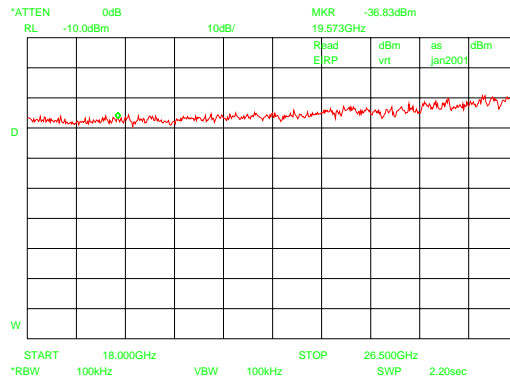
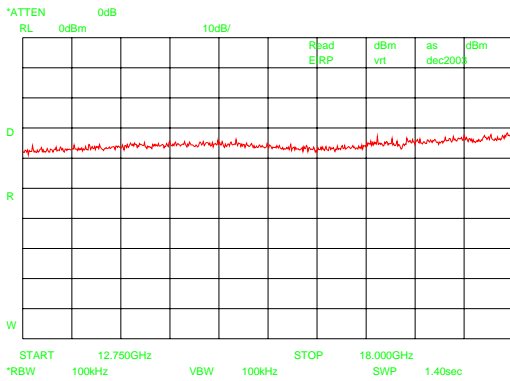
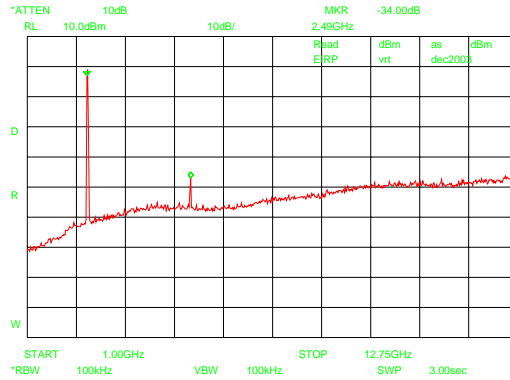
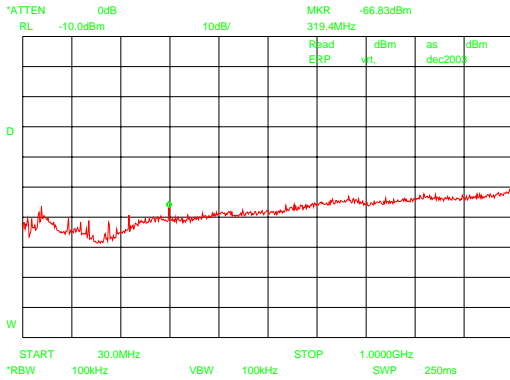

EQUIPMENT: SWL-2610U Spread Spectrum Direct Sequence Transceiver
FCC ID: E2XSWL-2610U

Section 8 Spurious Emissions (restricted bands, radiated)

NAME OF TEST: Spurious Emissions (Radiated)	PARA. NO.: 15.247(c)
---	----------------------

Test Results: Complies.

Measurement Data: See attached graphs.

Note: The graphs represent values calibrated in equivalent isotropic radiated power (eirp).
The relationship: $EIRP_{dBm} = E_{dB\mu V/m} - 95.4_{dB}$ applies

EQUIPMENT: SWL-2610U Spread Spectrum Direct Sequence Transceiver
FCC ID: E2XSWL-2610U

Channel 1: horizontal polarization

Peak detector measurement

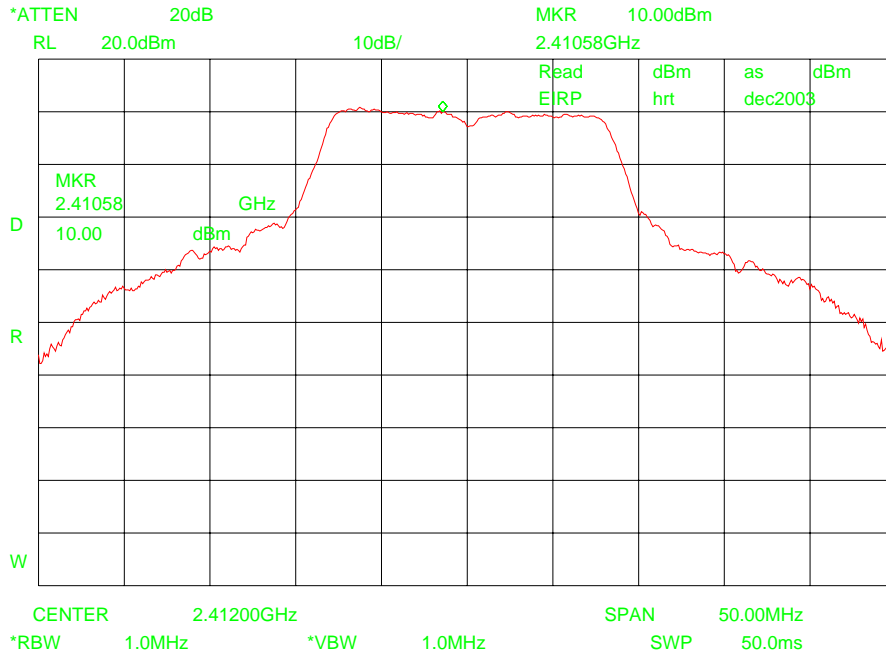

Average detector measurement

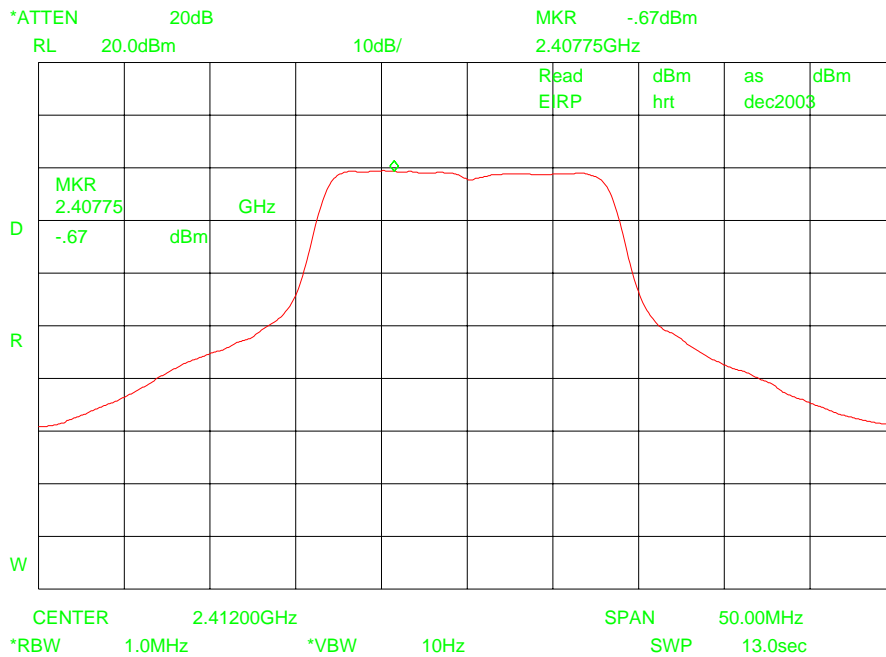

EQUIPMENT: SWL-2610U Spread Spectrum Direct Sequence Transceiver
FCC ID: E2XSWL-2610U

Delta-marker measurement

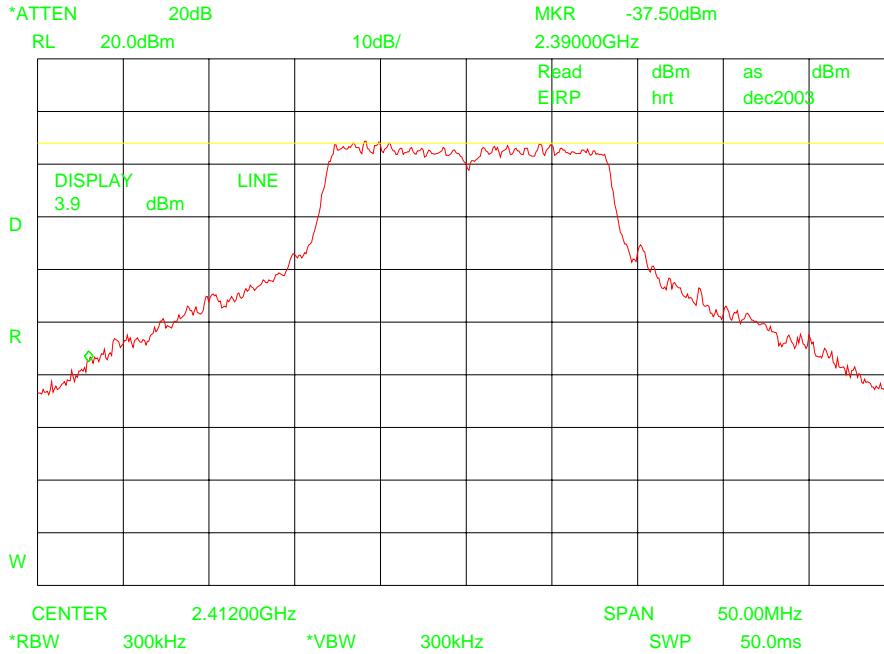

Restricted band edge level (average): $-0.67 + 95.4 - 41.2 = 53.33 \text{ dB}\mu\text{V/m}$

Restricted band edge level (peak): $8.16 + 95.4 - 40.2 = 65.2 \text{ dB}\mu\text{V/m}$

Test setting: 130

EQUIPMENT: SWL-2610U Spread Spectrum Direct Sequence Transceiver
FCC ID: E2XSWL-2610U

Channel 11: horizontal measurement

Peak detector measurement

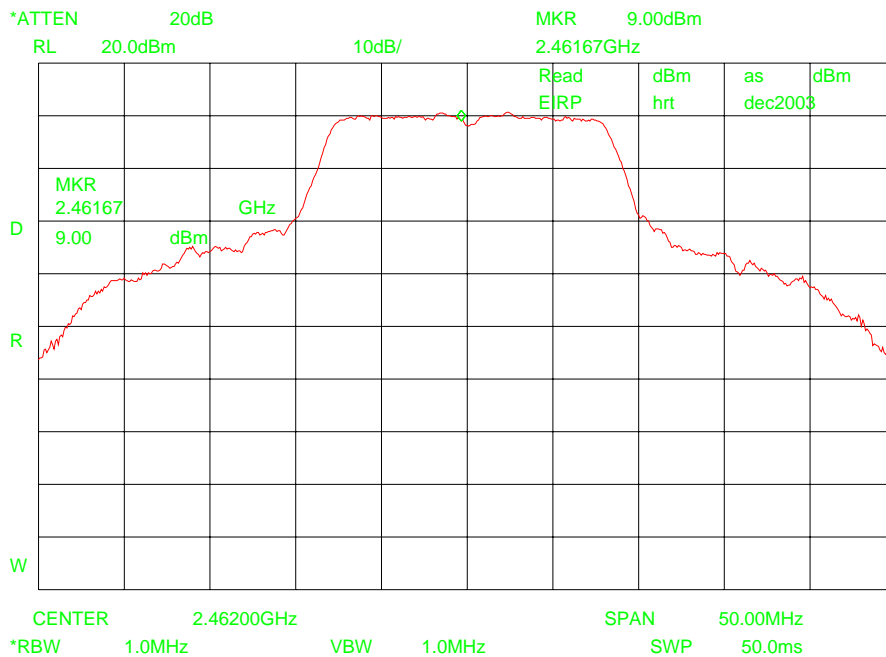

Average detector measurement

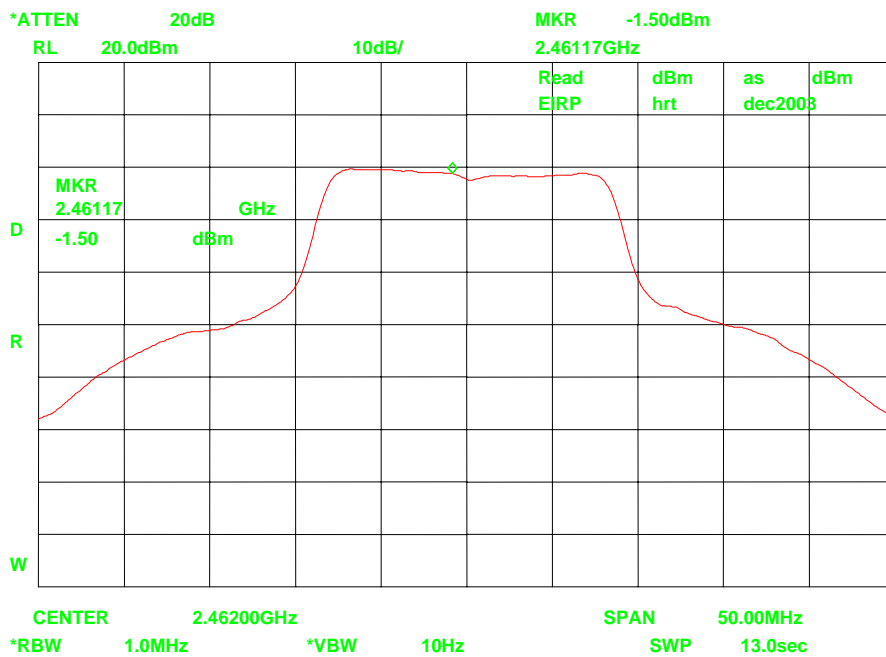

EQUIPMENT: SWL-2610U Spread Spectrum Direct Sequence Transceiver
FCC ID: E2XSWL-2610U

Delta-marker measurement

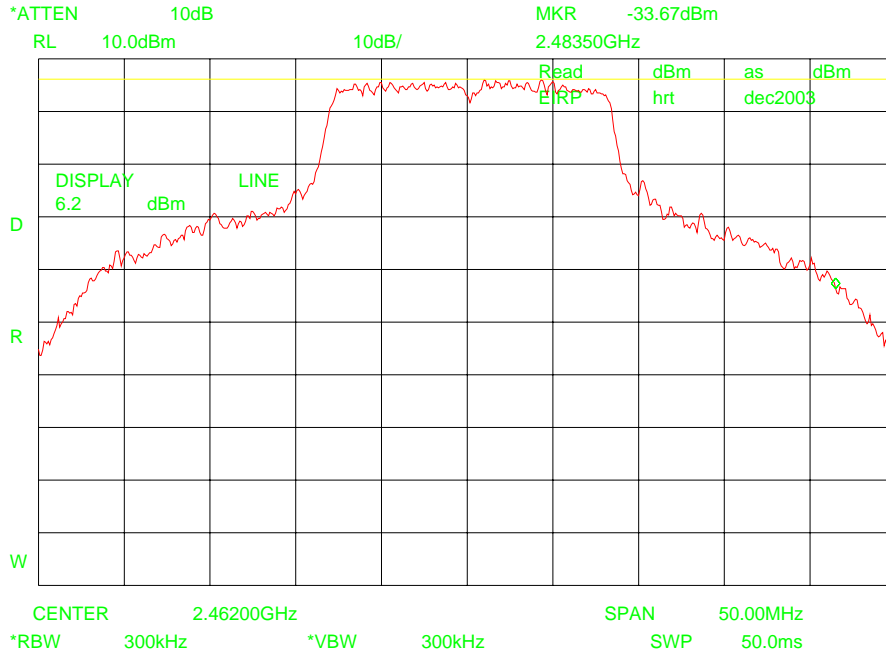

Restricted band edge level (average): $-1.50 + 95.40 - 39.90 = 54.00 \text{ dB}\mu\text{V/m}$

Restricted band edge level (peak): $9.00 + 95.40 - 39.90 = 64.30 \text{ dB}\mu\text{V/m}$

Test setting: 145

EQUIPMENT: SWL-2610U Spread Spectrum Direct Sequence Transceiver
FCC ID: E2XSWL-2610U

Section 9 Photographs

Conducted photograph

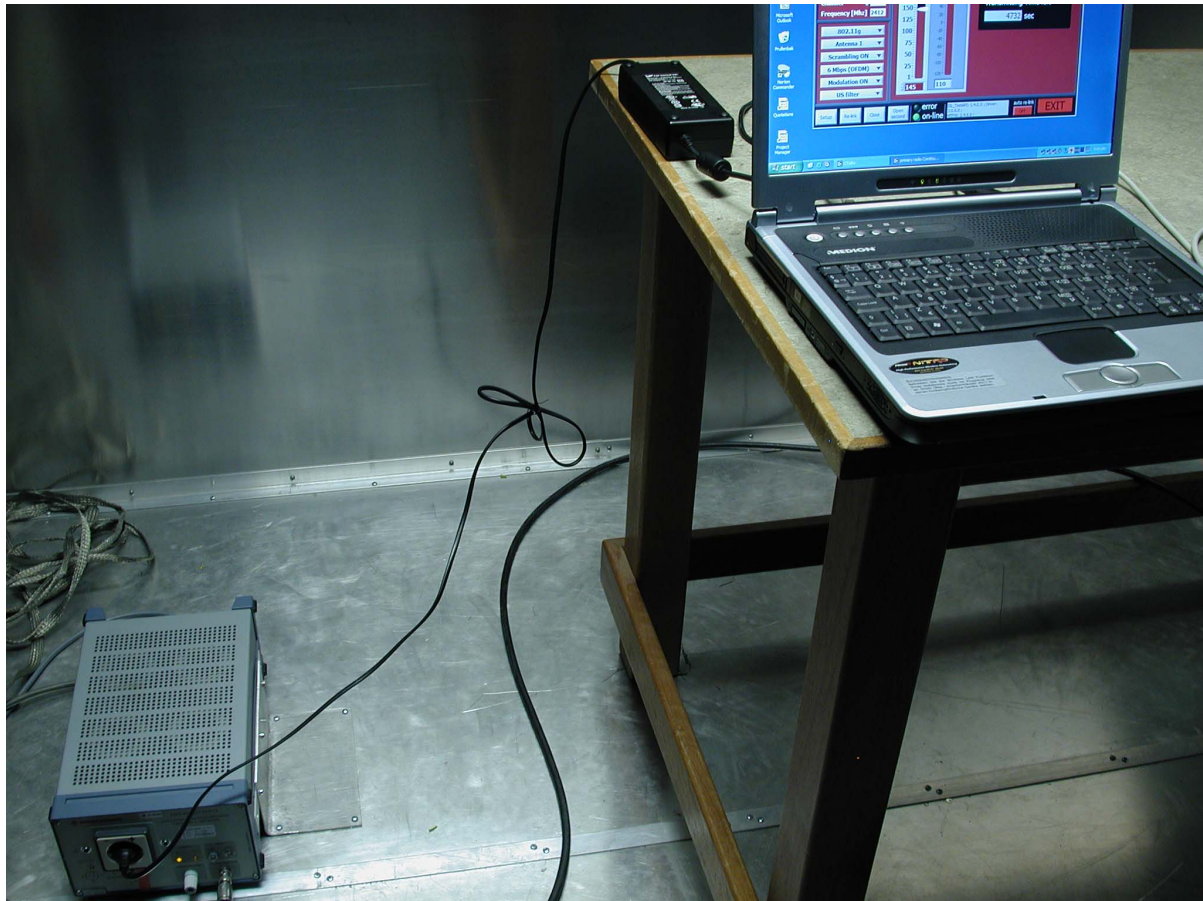

EQUIPMENT: SWL-2610U Spread Spectrum Direct Sequence Transceiver
FCC ID: E2XSWL-2610U

Radiated Photographs

Sample on the test table in anechoic room



EQUIPMENT: SWL-2610U Spread Spectrum Direct Sequence Transceiver
FCC ID: E2XSWL-2610U

Set up 0.03 –1 GHz



EQUIPMENT: SWL-2610U Spread Spectrum Direct Sequence Transceiver
FCC ID: E2XSWL-2610U

Set up 1 – 18 GHz



EQUIPMENT: SWL-2610U Spread Spectrum Direct Sequence Transceiver
FCC ID: E2XSWL-2610U

Set up 18 – 26 GHz



EQUIPMENT: SWL-2610U Spread Spectrum Direct Sequence Transceiver
FCC ID: E2XSWL-2610U

Section 10 Test equipment List

Description	Manufacturer	Model	Identification	Used at
Spectrum analyzer	Hewlett Packard	8563E	TE 00481	15.207(a);15.247 (a)(2); (c); (d)
Standard gain horn	Scientific Atlanta	12A-18	TE 00608	15.247(c)
Double ridged guide horn antenna	EMCO	3115	TE 00531	15.247(c)
Biconilog antenna	EMCO	3143	TE 00744	15.247(c)
Pre- amplifier	Hewlett Packard	8449B	TE 00092	15.247(c)
Pre-amplifier	Rohde & Schwarz	ESV-Z3	TE 00098	15.247(c)
Power meter	Hewlett Packard	435 B	TE 00249	15.247(b)(3)
Power sensor	Hewlett Packard	8484 A	TE 00245	15.247(b)(3)
40 dB fixed attenuator	Hewlett Packard	8491 B	TE 00406	15.247(b)(3)
Artificial Mains Network	Rohde & Schwarz	ESH2-Z5	TE 00208	15.207(a)

ANNEX A

TEST METHODOLOGIES

Minimum Standard:

The maximum peak power output shall not exceed 1 watt.

If transmitting antennas of directional gain greater than 6 dBi are used, the power shall be reduced by the amount in dB that the directional gain of the antenna exceeds 6 dBi.

Systems operating in the 2400-2483.5 MHz band that are used exclusively for fixed, point to point operation may employ transmitting antennas with directional gain greater than 6 dBi provided the maximum peak output power is reduced by 1 dB for every 3 dB that the directional gain of the antenna exceed 6 dBi.

Direct Measurement Method For Detachable Antennas:

If the antenna is detachable, a peak power meter is used to measure the power output with the transmitter operating into a 50 ohm load.

Calculation Of EIRP For Integral Antenna:

If the antenna is not detachable from the circuit then the Peak Power Output is derived from the peak radiated field strength of the fundamental emission by using the plane wave relation $GP/4\pi R^2 = E^2/120\pi$ and proceeding as follows:

$$P = \frac{E^2 R^2}{30G} = \frac{E^2 3^2}{30G}$$

where,

P = the equivalent isotropic radiated power in watts

E = the maximum measured field strength in V/m

R = the measurement range (3 meters)

G = the numeric gain of the transmit antenna in relation to an isotropic radiator

The RBW of the spectrum analyzer shall be set to a value greater than the measured 20 dB occupied bandwidth of the E.U.T.

Number of channels tested:

Tuning range	Number of channels tested	Channel location in band
1 MHz or less	1	middle
1 to 10 MHz	2	top and bottom
more than 10 MHz	3	top, middle, bottom

NAME OF TEST: Radiated Spurious Emissions

PARA. NO.: 15.247(c)

Minimum Standard: In any 100kHz bandwidth outside the 902 - 928 MHz bands emissions shall be at least 20 dB below the fundamental emission or shall not exceed the following field strength limits. **Emissions falling in the restricted bands of 15.205 shall not exceed the following field strength limits:**

Frequency (MHz)	Field Strength ($\mu\text{V/m}$ @ 3m)	Field Strength (dB @ 3m)
30 - 88	100	40.0
88 - 216	150	43.5
216 - 960	200	46.0
Above 960	500	54.0

THE SPECTRUM WAS SEARCHED TO THE 10th HARMONIC

15.205 Restricted Bands

MHz	MHz	MHz	GHz
0.09-0.11	16.42-16.423	399.9-410	4.5-5.25
0.495-0.505	16.69475-16.69525	608-614	5.35-5.46
2.1735-2.1905	16.80425-16.80475	960-1240	7.25-7.75
4.125-4.128	25.5-25.67	1300-1427	8.025-8.5
4.17725-4.17775	37.5-38.25	1435-1626.5	9.0-9.2
4.20725-4.20775	73-74.6	1645.5-1646.5	9.3-9.5
6.125-6.218	74.8-75.2	1660-1710	10.6-12.7
6.26775-6.26825	108-121.94	1718.8-1722.2	13.25-13.4
6.31175-6.31225	123-138	2200-2300	14.47-14.5
8.291-8.294	149.9-150.05	2310-2390	15.35-16.2
8.362-8.366	156.52475-156.52525	2483.5-2500	17.7-21.4
8.37625-8.38675	156.7-156.9	2655-2900	22.01-23.12
8.41425-8.41475	162.0125-167.17	3260-3267	23.6-24.0
12.29-12.293	167.72-173.2	3332-3339	31.2-31.8
12.51975-12.52025	240-285	3345.8-3358	36.43-36.5
12.57675-12.57725	322-335.4	3600-4400	Above 38.6
13.36-13.41			

Number of channels tested:

Tuning range	Number of channels tested	Channel location in band
1 MHz or less	1	middle
1 to 10 MHz	2	top and bottom
more than 10 MHz	3	top, middle, bottom

ANNEX B

CROSS REFERENCE TABLE RSS-FCC

Cross reference table

Frequency hopping 2,4 GHz	
CNR RSS-210 Issue 5	FCC 47 CFR Ch. 1 (10-1-02 Edition)
par. 6.2.2 (o)(a)	§ 15.247
Amendment 1(I)	§ 15.247
par. 6.2.1	§ 15.209
par. 6.3	§ 15.205

Direct Sequence 2,4 GHz	
CNR RSS-210 Issue 5	FCC 47 CFR Ch. 1 part 15 subpart C
-	15.207(a) conducted emissions
Amendment 1 I (iv)	15.247(a)(2) minimum 6 dB bandwidth
par. 6.2.2(o)(b)	15.247(b)(3) max. peak power output
par. 6.2.2(o)(b)	15.247(d) peak power spectral density
Par. 6.2.2(o)(e1)	15.247(c) spurious emissions