

Rhein Tech Laboratories
360 Herndon Parkway
Suite 1400
Herndon, VA 20170
www.rheintech.com

Client: Samsung EMC
Model: SWL-2200U
FCC ID: E2XSWL-2200U
FCC/IC: 15.247/RSS-210
Report #: 2002055

APPENDIX H: SCHEMATICS

Please see the following pages.

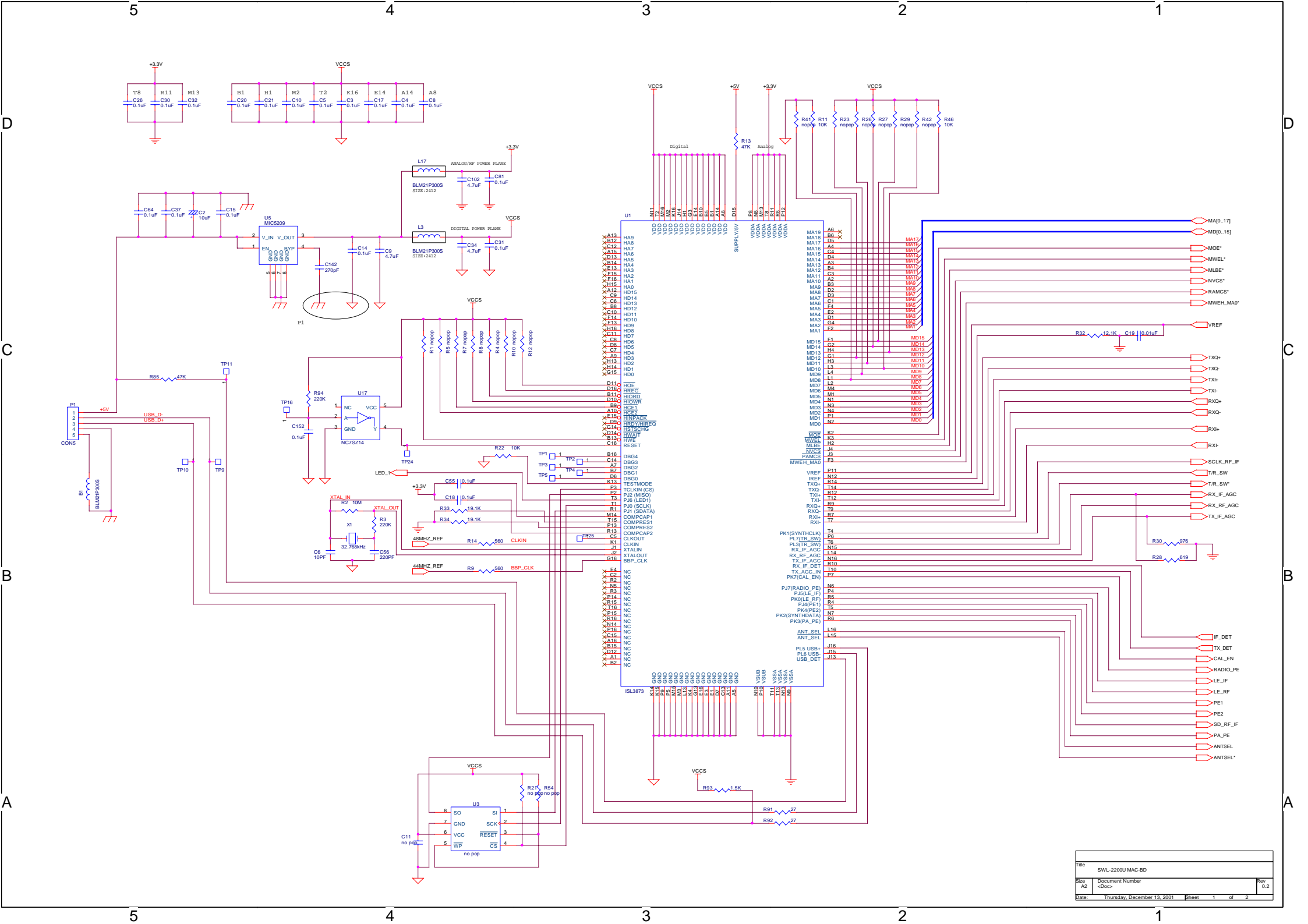

File			SWL-2200U MAC-BD
Size			Document Number
Ac			<Doc>
Date:	Thursday, December 13, 2001	Sheet	1 of 2

- U1
- XA13 HA9
 - XA12 HA8
 - XA11 HA7
 - XA10 HA6
 - XA09 HA5
 - XA08 HA4
 - XA07 HA3
 - XA06 HA2
 - XA05 HA1
 - XA04 HA0
 - XA03 HD15
 - XA02 HD14
 - XA01 HD13
 - HA HD12
 - HA HD11
 - HA HD10
 - HA HD9
 - HA HD8
 - HA HD7
 - HA HD6
 - HA HD5
 - HA HD4
 - HA HD3
 - HA HD2
 - HA HD1
 - HA HD0
 - D11C RCE
 - D11B DRREG
 - D11A DRD
 - D10C DIOWR
 - D10B DCE
 - D10A DINFACK
 - D09C DROV/HIBFG
 - D09B DINSTSCHG
 - D09A D09
 - D08C D08
 - D08B D07
 - D08A D06
 - D07C D07
 - D07B D05
 - D07A D04
 - D06C D06
 - D06B D05
 - D06A D04
 - D05C D05
 - D05B D03
 - D05A D02
 - D04C D04
 - D04B D03
 - D04A D02
 - D03C D03
 - D03B D01
 - D03A D00
 - D02C D02
 - D02B D01
 - D02A D00
 - D01C D01
 - D01B D00
 - D01A D00
 - D00C D00
 - D00B D00
 - D00A D00
 - D00
 - E4 NC
 - E3 NC
 - E2 NC
 - E1 NC
 - E0 NC
 - E15 NC
 - E14 NC
 - E13 NC
 - E12 NC
 - E11 NC
 - E10 NC
 - E09 NC
 - E08 NC
 - E07 NC
 - E06 NC
 - E05 NC
 - E04 NC
 - E03 NC
 - E02 NC
 - E01 NC
 - E00 NC
 - A1 NC
 - A2 NC
- ISL3873
- K14 GND
 - K13 GND
 - K12 GND
 - K11 GND
 - K10 GND
 - K09 GND
 - K08 GND
 - K07 GND
 - K06 GND
 - K05 GND
 - K04 GND
 - K03 GND
 - K02 GND
 - K01 GND
 - K00 GND
 - N00 VSSB
 - N01 VSSB
 - N02 VSSA
 - N03 VSSA
 - N04 VSSA
 - N05 VSSA
 - N06 VSSA
 - N07 VSSA
 - N08 VSSA
 - N09 VSSA
 - N10 VSSA
 - N11 VSSA
 - N12 VSSA
 - N13 VSSA
 - N14 VSSA
 - N15 VSSA
 - N16 VSSA
 - N17 VSSA
 - N18 VSSA
 - N19 VSSA
 - N20 VSSA
 - N21 VSSA
 - N22 VSSA
 - N23 VSSA
 - N24 VSSA
 - N25 VSSA
 - N26 VSSA
 - N27 VSSA
 - N28 VSSA
 - N29 VSSA
 - N30 VSSA
 - N31 VSSA
 - N32 VSSA
 - N33 VSSA
 - N34 VSSA
 - N35 VSSA
 - N36 VSSA
 - N37 VSSA
 - N38 VSSA
 - N39 VSSA
 - N40 VSSA
 - N41 VSSA
 - N42 VSSA
 - N43 VSSA
 - N44 VSSA
 - N45 VSSA
 - N46 VSSA
 - N47 VSSA
 - N48 VSSA
 - N49 VSSA
 - N50 VSSA
 - N51 VSSA
 - N52 VSSA
 - N53 VSSA
 - N54 VSSA
 - N55 VSSA
 - N56 VSSA
 - N57 VSSA
 - N58 VSSA
 - N59 VSSA
 - N60 VSSA
 - N61 VSSA
 - N62 VSSA
 - N63 VSSA
 - N64 VSSA
 - N65 VSSA
 - N66 VSSA
 - N67 VSSA
 - N68 VSSA
 - N69 VSSA
 - N70 VSSA
 - N71 VSSA
 - N72 VSSA
 - N73 VSSA
 - N74 VSSA
 - N75 VSSA
 - N76 VSSA
 - N77 VSSA
 - N78 VSSA
 - N79 VSSA
 - N80 VSSA
 - N81 VSSA
 - N82 VSSA
 - N83 VSSA
 - N84 VSSA
 - N85 VSSA
 - N86 VSSA
 - N87 VSSA
 - N88 VSSA
 - N89 VSSA
 - N90 VSSA
 - N91 VSSA
 - N92 VSSA
 - N93 VSSA
 - N94 VSSA
 - N95 VSSA
 - N96 VSSA
 - N97 VSSA
 - N98 VSSA
 - N99 VSSA
 - N100 VSSA

- MA19 MA17
- MA18 MA16
- MA17 MA15
- MA16 MA14
- MA15 MA13
- MA14 MA12
- MA13 MA11
- MA12 MA10
- MA11 MA9
- MA10 MA8
- MA9 MA8
- MA8 MA7
- MA7 MA6
- MA6 MA5
- MA5 MA4
- MA4 MA3
- MA3 MA2
- MA2 MA1
- MA1 MA0
- MD15 MD15
- MD14 MD14
- MD13 MD13
- MD12 MD12
- MD11 MD11
- MD10 MD10
- MD9 MD9
- MD8 MD8
- MD7 MD7
- MD6 MD6
- MD5 MD5
- MD4 MD4
- MD3 MD3
- MD2 MD2
- MD1 MD1
- MD0 MD0
- MD15 MD15
- MD14 MD14
- MD13 MD13
- MD12 MD12
- MD11 MD11
- MD10 MD10
- MD9 MD9
- MD8 MD8
- MD7 MD7
- MD6 MD6
- MD5 MD5
- MD4 MD4
- MD3 MD3
- MD2 MD2
- MD1 MD1
- MD0 MD0
- TXQ+ TXQ+
- TXQ- TXQ-
- TXI+ TXI+
- TXI- TXI-
- RXQ+ RXQ+
- RXQ- RXQ-
- RXI+ RXI+
- RXI- RXI-
- SCLK_RF_IF SCLK_RF_IF
- TTR_SW TTR_SW
- TX_IF_AGC TX_IF_AGC
- RX_IF_AGC RX_IF_AGC
- TX_IF_AGC TX_IF_AGC
- RX_IF_AGC RX_IF_AGC
- IF_DET IF_DET
- TX_DET TX_DET
- CAL_EN CAL_EN
- RADIO_PE RADIO_PE
- LE_IF LE_IF
- LE_RF LE_RF
- PE1 PE1
- SD_RF_IF SD_RF_IF
- PA_PE PA_PE
- ANTSEL ANTSEL
- ANTSEL ANTSEL

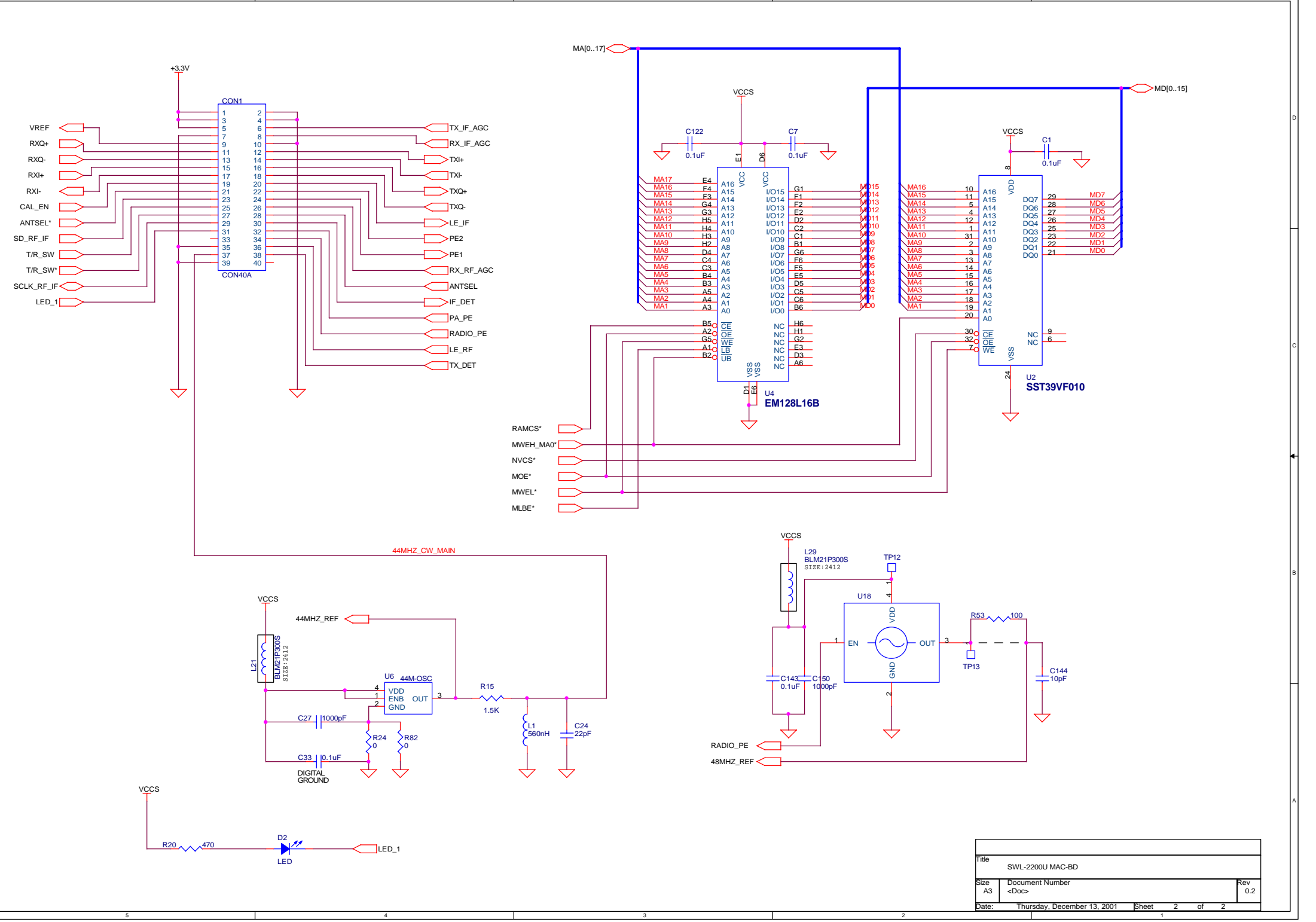

Title		
SWL-2200U MAC-BD		
Size	Document Number	Rev
A3	<Doc>	0.2
Date:	Thursday, December 13, 2001	Sheet 2 of 2

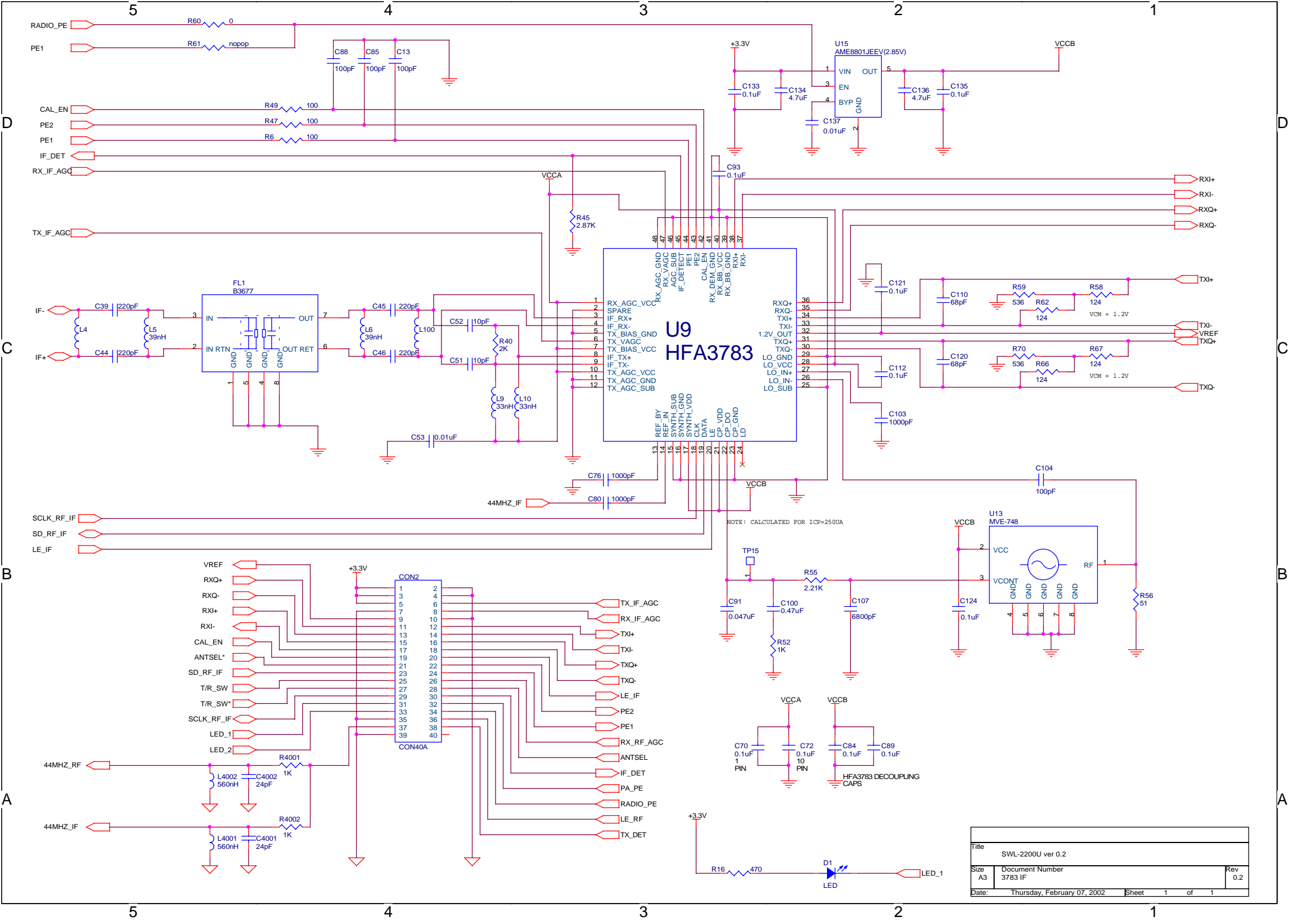

Title			SWL-2200U ver 0.2		
Size	Document Number			Rev	
A3	3783 IF			0.2	
Date:	Thursday, February 07, 2002	Sheet	1	of	1

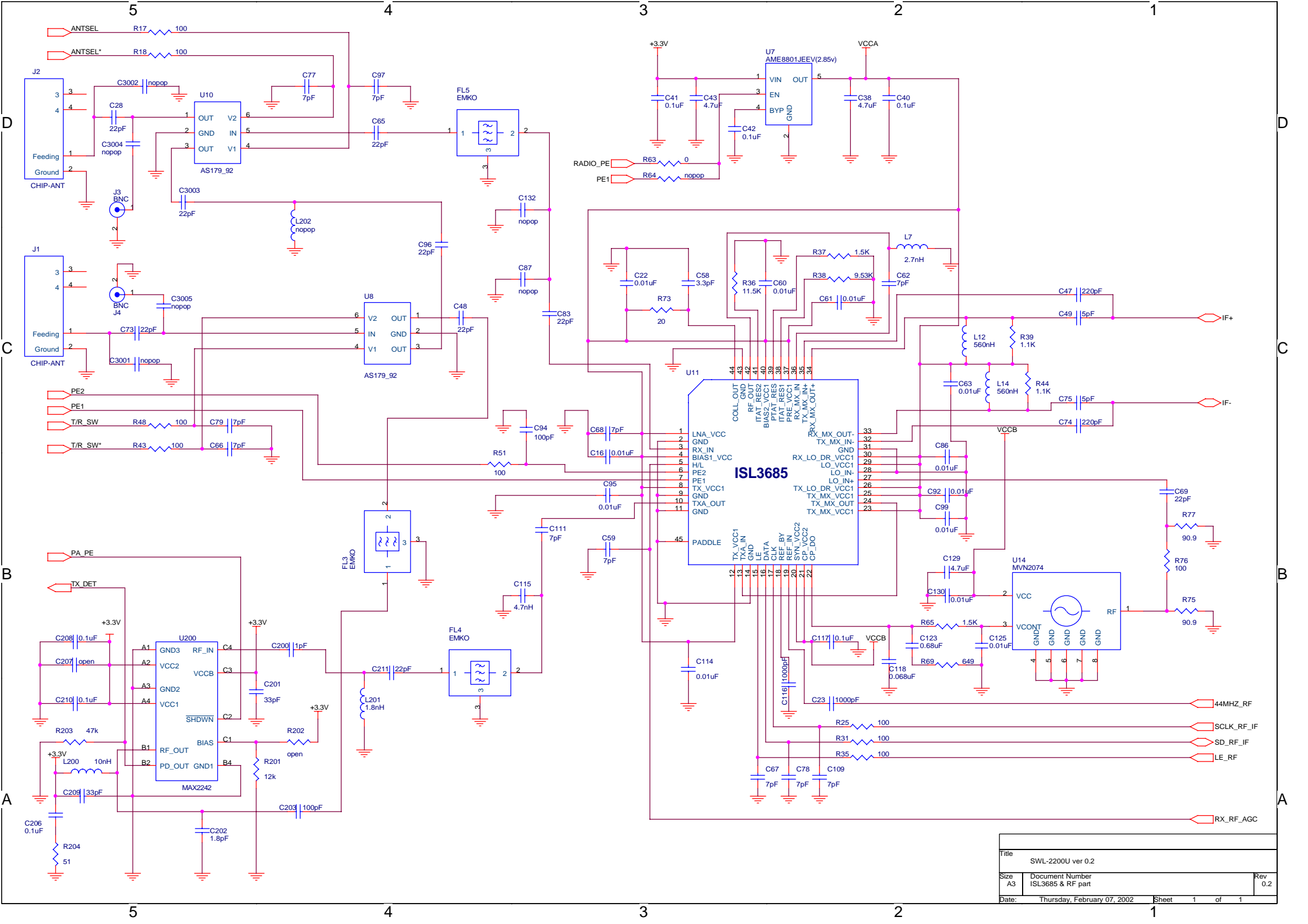

Title			SWL-2200U ver 0.2		
Size	Document Number		Rev		
A3	ISL3685 & RF part		0.2		
Date:	Thursday, February 07, 2002	Sheet	1	of	1