

FCC ID SAMPLE LABEL & LOCATION

LABELLING REQUIREMENTS
PER §2.925

The Label shown shall be permanently affixed at a conspicuous location on the battery cover of the device and be readily visible to the user at the time of purchase.
 If the battery cover is removed, this device does not work.

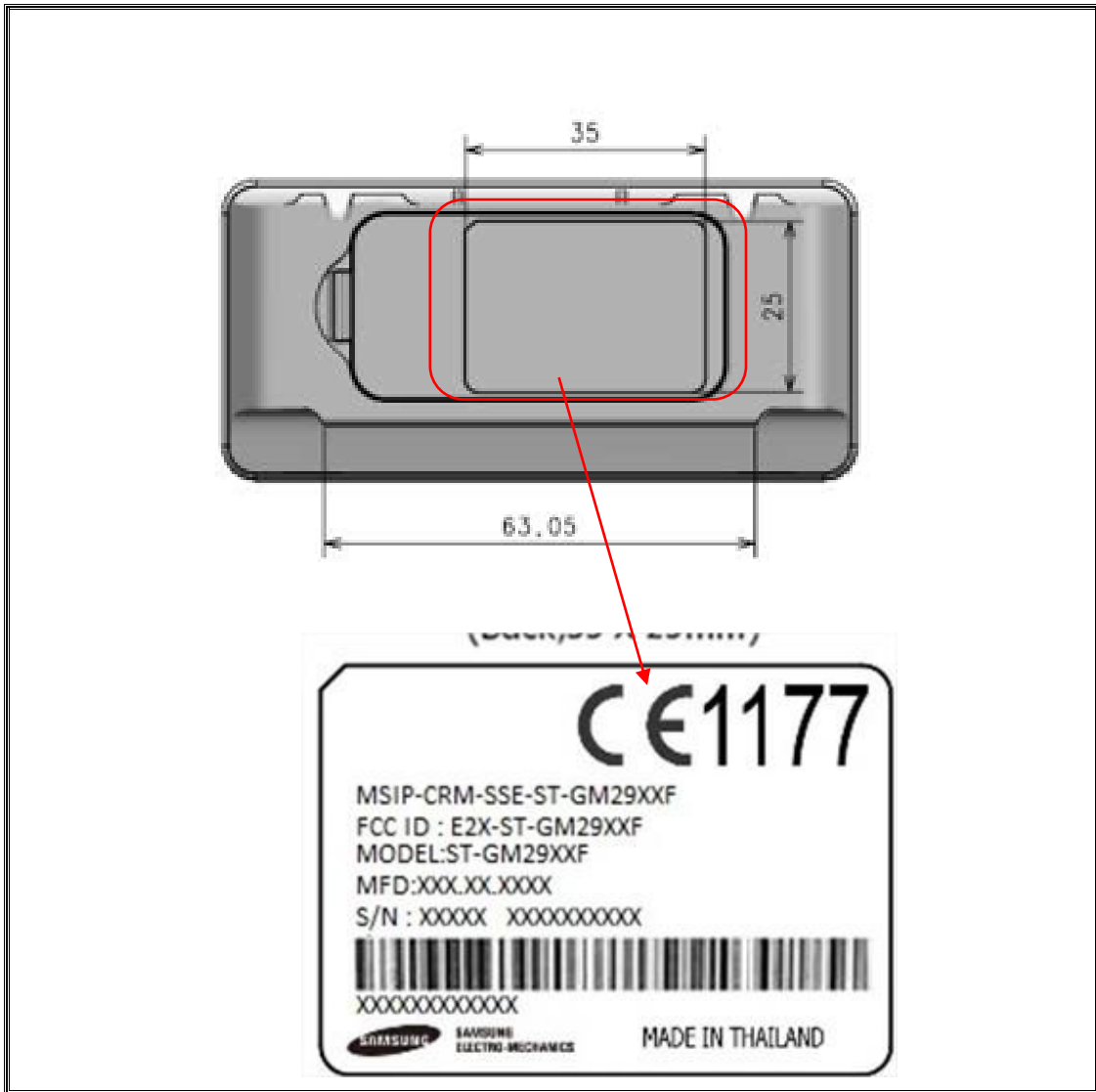

- The FCC label shown is representative of the label that will appear on the radio when in production. Other information may also be included on this label.
- The device is so small that it is not practicable to place the statement specified under 15.19 statement request, the information required by this paragraph shall be placed in a prominent location in the user's manual.