

Regulatory WWAN Antenna Information

(English Language Required for Intel Regulatory Review / Approval)

**(OEM/ODM or antenna vendor is required to complete this document with platform antenna information.
Remove Intel references and make this your own document)**

Platform	
Platform Owner	DELL
Brand Name	DELL
Model Name	T06H
ODM	Compal Electronics, Inc.
Target Launch Date	2022/07/26
Antenna	
Manufacturer	Auden Techno Corp.
Part Number	■ Tx1/Rx1 Antenna WWAN Main; B32519-00 (DC33002P44L)
	■ Rx2 Antenna WWAN Aux; B32520-00 (DC33002P45L)
	■ Tx2/Rx3 Antenna MIMO2; B32520-00 (DC33002P45L)
	■ Rx4 Antenna MIMO3; B325122-30 (DC33002P47L)
Module	
With WWAN Module	Foxconn T99W175/T77W968
(Check Box)	

Antenna Sample / Antenna Data Requirements for worldwide regulatory approval

Section	Description of Required OEM / ODM Antenna Information	US / IC	EU	Japan	Taiwan	S.Korea
1A	Part Number for Antenna only	Required	Required	Required	Required	Required
1B	Antenna Manufacturer Name	Required	Required	Required	Required	Required
1C	Description of Antenna Type	Required	N/A	N/A	N/A	N/A
1D	Part number of Antenna Assembly / cable impedance, length & diameter.	Required	Desired	Desired	Desired	Desired
1E	Tx1, Tx2 & Tx3 antenna (Peak Gain W/ cable loss) *	Required	Required	Required	Required	Required
	1E OR 1F, 1G, 1H					
1F	Tx1, Tx2 & Tx3 antenna (Peak Gain only) *	Required	Required	Required	Required	Required
1G	VSWR of cable including connector	Required	Required	Required	Required	Required
1H	Tx1, Tx2 & Tx3 antenna (Cable loss W/ connector) *	Required	Required	Required	Required	Required
2	Dimensioned Photographs and Drawings of Tx1, Tx2, and Tx3 (or Rx3) antennas	Required	Required	Required	Required	Required
3	Radiation patterns of antennas loaded in the host platform.	Required	Desired	Required	N/A	Required
4	Platform model name / number - correlated to antenna manufacturer and antenna part number	Required	Required	Desired	Required	Desired
5	Photograph(s) or Drawings showing location of antennas in platform. (S. Korea requires <u>photographs of antennas for approval submission</u>). <u>Taiwan requires pictures of each antenna type shown in the system.</u>	Required	Required	Desired	<u>Required (Photos)</u>	<u>Required (Photos)</u>
6	Mech. drawings / photos with dimensions of antenna locations and distance from end-user (For evaluation of SAR testing requirement).	Required	N/A	N/A	N/A	N/A
7	Photograph(s) or Drawings showing the location of all antennas (WLAN, other) and distance between those transmitting antennas. Information will be used to evaluate whether co-location testing is required.	Required	N/A	N/A	N/A	N/A
8	Local representative contact information for LMA/ PARS process.	Required	N/A	N/A	N/A	N/A

Table of contents

1. Applicable test method
2. Test & System Description
 - a. Test setup
 - b. Equipment list
3. Setup photo

[Section 1. Antenna Assembly Specifications](#)

[Section 2. Dimensioned Photos or Drawings of Antennas](#)

[Section 3. Radiation characteristics of antenna loaded in Host Platform](#)

[Section 4. Antenna Host Platform Location Information](#)

[Section 5. Antenna dimensional information for SAR evaluation](#)

[Section 6. Diagram Example of Co-Location Antenna Separation](#)

1. **Applicable test methods**

<insert test description here for test method>

This test report is prepared for host antenna testing under a Full Anechoic Chamber.

2. **Test & System Description**

a. Test setup

<insert test diagram here for test site utilized>

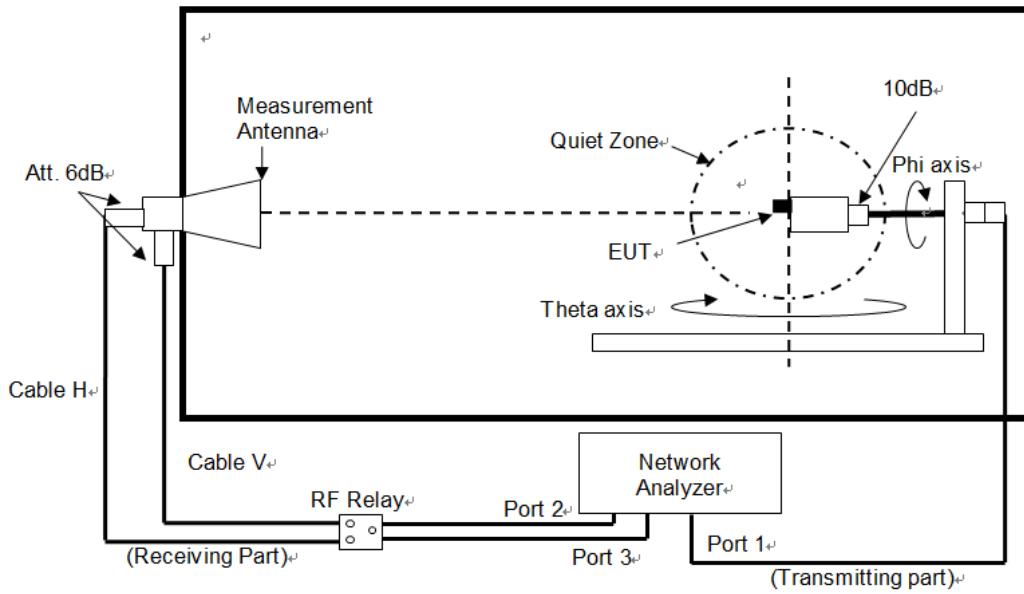

b. Equipment list

<insert test diagram here for test site utilized>

Name	Manufacturer	Type/Model	Serial Number
ENA Series Network Analyzer	Keysight	E5080B	MY59101211
RF Switch	Keysight	3499A	MY42000955
Multi-Axis Positioner Controller	ETS-Lindgren	2090	N/A
Medium-Duty Positioner	ETS-Lindgren	2015	N/A
Measurement Horn Antenna	EMCO	3164-08	00086722

3. Setup photo

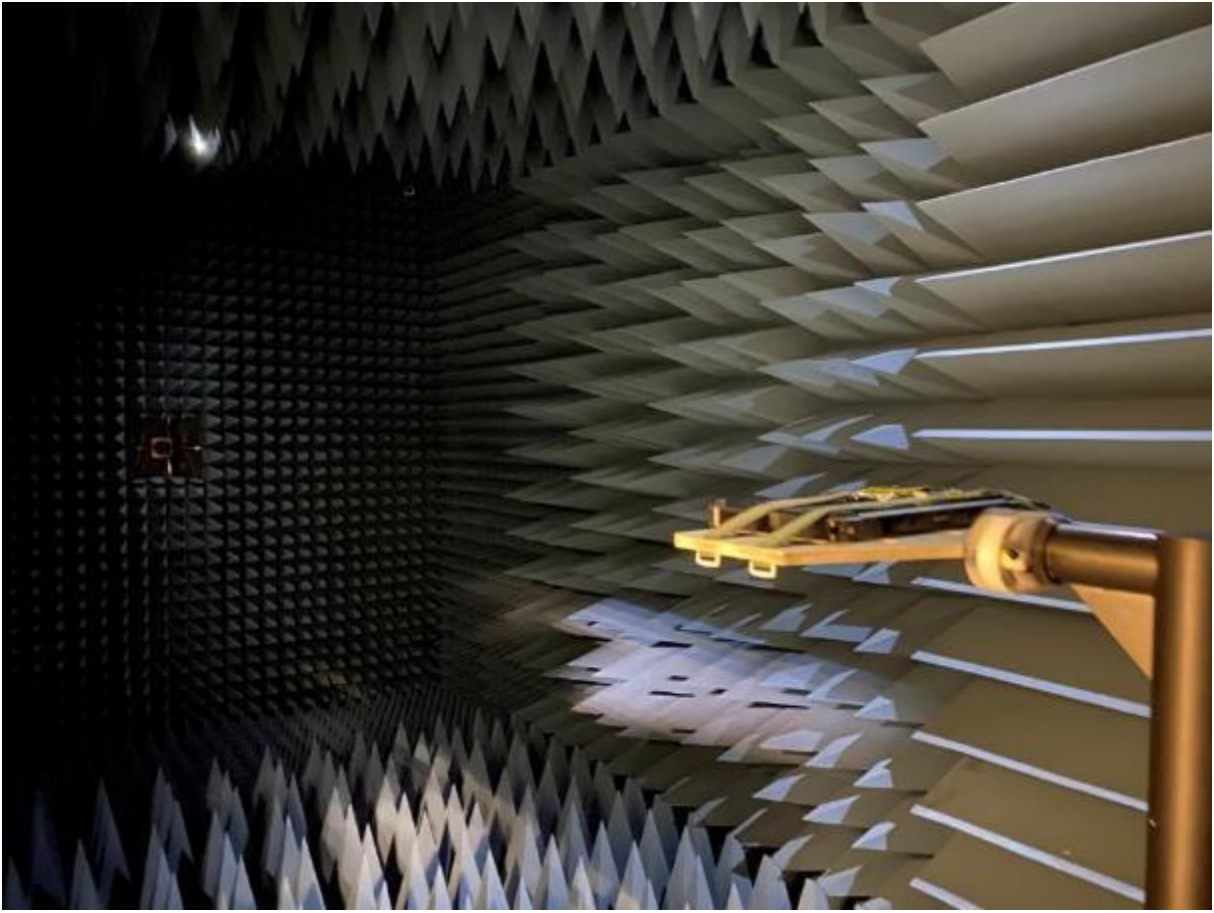

Antenna Information

Section 1. Antenna Assembly Specifications

1A	1B	1C	1D	1E	1F	1G	1H
Antenna Part Number	Manufacture	Antenna Type	Cable Assembly Part Number and Information	*Peak Gain W/ Cable loss (dBi)	Peak Gain w/o Cable Loss (dBi)	VSWR	Cable Loss (dBi)
P/N: B32519-00 (DC33002P44L) Tx1/ Rx1 Antenna	Auden Techno Corp.	PIFA	(1) Cable P/N: SY113L/50-146 (2) Cable length: 99mm diameter: 1.13mm 50 ohm Coaxial (3)Connector P/N: I-PEX MHF1	698-821MHz -1.69 dBi (peak)	698-821MHz -1.58 dBi (peak)	698-821MHz 3.0 max	698-821MHz 0.11 dBi (peak)
				824-960MHz 0.10 dBi (peak)	824-960MHz 0.23 dBi (peak)	824-960MHz 3.0 max	824-960MHz 0.13 dBi (peak)
				1425-1515MHz -0.96 dBi (peak)	1425-1515MHz -0.80 dBi (peak)	1425-1515MHz 3.0 max	1425-1515MHz 0.16 dBi (peak)
				1710-2200MHz -0.64 dBi (peak)	1710-2200MHz -0.46 dBi (peak)	1710-2200MHz 3.0 max	1710-2200MHz 0.18 dBi (peak)
				2300-2690MHz -0.30 dBi (peak)	2300-2690MHz -0.10 dBi (peak)	2300-2690MHz 3.0 max	2300-2690MHz 0.20 dBi (peak)
				3400-3800MHz -2.01 dBi (peak)	3400-3800MHz -1.74 dBi (peak)	3400-3800MHz 3.0 max	3400-3800MHz 0.27 dBi (peak)
				4200-4700MHz -0.89 dBi (peak)	4200-4700MHz -0.59 dBi (peak)	4200-4700MHz 3.0 max	4200-4700MHz 0.30 dBi (peak)
				5150-5925MHz 0.69 dBi (peak)	5150-5925MHz 1.03 dBi (peak)	5150-5925MHz 3.0 max	5150-5925MHz 0.34 dBi (peak)
P/N: B32520-00 (DC33002P45L) Rx2 Antenna	Auden Techno Corp.	PIFA	(1) Cable P/N: SY113L/50-145 (2) Cable length: 237mm diameter: 1.13mm 50 ohm Coaxial (3)Connector P/N: I-PEX MHF4	717-821MHz -0.53 dBi (peak)	717-821MHz -0.25 dBi (peak)	717-821MHz 3.0 max	717-821MHz 0.28 dBi (peak)
				824-960MHz -1.87 dBi (peak)	824-960MHz -1.55 dBi (peak)	824-960MHz 3.0 max	824-960MHz 0.32 dBi (peak)
				1425-1515MHz -0.82 dBi (peak)	1425-1515MHz -0.45 dBi (peak)	1425-1515MHz 3.0 max	1425-1515MHz 0.37 dBi (peak)
				1557-1610 MHz -2.23 dBi (peak)	1557-1610 MHz -1.82 dBi (peak)	1557-1610 MHz 3.0 max	1557-1610 MHz 0.41 dBi (peak)
				1805-2200MHz -2.82 dBi (peak)	1805-2200MHz -2.40 dBi (peak)	1805-2200MHz 3.0 max	1805-2200MHz 0.42 dBi (peak)
				2300-2690MHz -1.09 dBi (peak)	2300-2690MHz -0.61 dBi (peak)	2300-2690MHz 3.0 max	2300-2690MHz 0.48 dBi (peak)
				3400-3800MHz -1.81 dBi (peak)	3400-3800MHz -1.17 dBi (peak)	3400-3800MHz 3.0 max	3400-3800MHz 0.64 dBi (peak)
				4200-4700MHz -0.96 dBi (peak)	4200-4700MHz -0.24 dBi (peak)	4200-4700MHz 3.0 max	4200-4700MHz 0.72 dBi (peak)
5150-5925MHz -2.42 dBi (peak)	5150-5925MHz -1.60 dBi (peak)	5150-5925MHz 3.0 max	5150-5925MHz 0.82 dBi (peak)				

1A Antenna Part Number	1B Manufacture	1C Antenna Type	1D Cable Assembly Part Number and Information	1E *Peak Gain W/ Cable loss (dBi)	1F Peak Gain w/o Cable Loss (dBi)	1G VSWR	1H Cable Loss (dBi)
P/N: B32520-00 (DC33002P45L) Tx2/ Rx3 Antenna	Auden Techno Corp.	PIFA	(1) Cable P/N: SY113L/50-160 (2) Cable length: 36mm diameter: 1.13mm 50 ohm Coaxial (3)Connector P/N: I-PEX MHF1	1710-2200MHz -0.34 dBi (peak)	1710-2200MHz -0.28 dBi (peak)	1710-2200MHz 3.0 dBi (peak)	1710-2200MHz 0.06 dBi (peak)
				2300-2690MHz 0.33 dBi (peak)	2300-2690MHz 0.40 dBi (peak)	2300-2690MHz 3.0 dBi (peak)	2300-2690MHz 0.07 dBi (peak)
				3400-3800MHz 0.41 dBi (peak)	3400-3800MHz 0.51 dBi (peak)	3400-3800MHz 3.0 dBi (peak)	3400-3800MHz 0.10 dBi (peak)
				4200-5000MHz -0.68 dBi (peak)	4200-5000MHz -0.57 dBi (peak)	4200-5000MHz 3.0 dBi (peak)	4200-5000MHz 0.11 dBi (peak)
P/N: B32522-30 (DC33002P47L) Rx4 Antenna	Auden Techno Corp.	PIFA	(1) Cable P/N: SY113L/50-164 (2) Cable length: 228mm diameter: 1.13mm 50 ohm Coaxial (3)Connector P/N: I-PEX MHF4	1805-2200MHz -1.54 dBi (peak)	1805-2200MHz -0.98 dBi (peak)	1805-2200MHz 3.0 dBi (peak)	1805-2200MHz 0.56 dBi (peak)
				2300-2690MHz -0.16 dBi (peak)	2300-2690MHz 0.49 dBi (peak)	2300-2690MHz 3.0 dBi (peak)	2300-2690MHz 0.65 dBi (peak)
				3400-3800MHz -2.62 dBi (peak)	3400-3800MHz -1.76 dBi (peak)	3400-3800MHz 3.0 dBi (peak)	3400-3800MHz 0.86 dBi (peak)
				4200-5000MHz 0.17 dBi (peak)	4200-5000MHz 1.13 dBi (peak)	4200-5000MHz 3.0 dBi (peak)	4200-5000MHz 0.96 dBi (peak)

- Antenna Peak Gain required being test in system basis.
- 1E frame contend absolutely peak antenna gain include H/V

Antenna Peak Gain Table: Low and middle band

Frequency (MHz)	Tx1 / Rx1 antenna		Rx2 antenna	
	Horizontal	Vertical	Horizontal	Vertical
	(dBi)	(dBi)	(dBi)	(dBi)
698	-4.21	-1.76		
703	-3.95	-1.71		
707.5	-3.82	-1.76		
717	-3.32	-1.79	-1.24	-0.82
725.5	-3.18	-1.69	-1.09	-0.85
748	-3.16	-2.27	-0.88	-0.74
756	-3.21	-2.06	-0.99	-0.53
768	-3.06	-1.96	-1.35	-0.87
777	-3.23	-1.94	-2.34	-1.41
782	-3.36	-1.94	-2.67	-1.69
787	-3.49	-1.92	-2.88	-1.83
814	-3.63	-1.80	-3.13	-3.41
824	-3.28	-1.78	-3.39	-3.22
832	-3.07	-1.75	-3.56	-3.14
836.5	-2.95	-1.61	-3.65	-2.84
849	-2.48	-1.17	-3.71	-2.20
862	-1.76	-0.58	-3.41	-1.87
880	-1.54	-0.42	-3.43	-2.20
897.5	-1.67	0.10	-3.54	-2.60
915	-1.22	-0.12	-3.95	-3.11
925	-0.89	-0.34	-4.27	-3.23
960	-4.23	-1.79	-6.77	-4.21
1427.9	-6.51	-3.49	-4.86	-3.17
1447.9	-4.29	-3.10	-4.17	-1.75
1455.4	-4.21	-2.91	-4.01	-1.47
1462.9	-4.14	-2.69	-3.56	-1.23
1496	-4.06	-1.32	-4.15	-0.82
1510.9	-4.03	-0.96	-4.91	-0.98
1557			-5.17	-2.23
1575			-4.80	-2.63
1610			-4.12	-2.67

High band

Frequency (MHz)	Tx1 / Rx1 antenna		Rx2 antenna	
	Horizontal (dBi)	Vertical (dBi)	Horizontal (dBi)	Vertical (dBi)
1710	-1.94	-1.05		
1732.5	-1.86	-0.94		
1747.5	-2.12	-1.15		
1755	-2.29	-1.33		
1785	-3.33	-1.06		
1805	-3.58	-1.32	-4.81	-3.52
1850	-2.84	-1.33	-5.41	-3.73
1880	-1.88	-0.90	-4.93	-3.53
1910	-1.57	-0.95	-3.83	-3.77
1920	-1.66	-0.84	-3.90	-3.45
1950	-1.65	-0.64	-4.25	-2.83
1980	-1.53	-0.86	-4.33	-2.82
2110	-2.27	-1.24	-4.56	-3.36
2200	-2.08	-2.03	-5.14	-4.50
2300	-0.81	-1.67	-5.25	-2.41
2305	-0.91	-1.59	-5.29	-2.23
2315	-1.41	-1.63	-5.50	-2.01
2350	-3.50	-2.22	-5.95	-1.76
2400	-4.12	-4.07	-5.91	-2.65
2500	-3.72	-0.30	-5.18	-4.79
2570	-3.99	-1.13	-3.68	-2.74
2595	-4.76	-1.20	-3.55	-1.91
2620	-5.07	-1.07	-3.32	-1.09
2690	-5.35	-3.18	-2.30	-1.19
3400	-2.11	-3.94	-5.31	-3.68
3500	-2.01	-4.03	-5.33	-3.48
3600	-2.39	-4.55	-5.23	-5.66
3700	-2.81	-4.05	-4.06	-3.39
3800	-2.68	-3.31	-2.01	-1.81
4200	-2.58	-1.90	-1.79	-3.10
4400	-0.89	-3.11	-2.06	-3.08
4700	-0.90	-2.65	-0.96	-3.13
5150	0.69	-3.63	-3.41	-3.18
5537.5	-3.20	-0.91	-2.42	-5.12
5925	-1.08	-0.12	-4.26	-7.95

Frequency (MHz)	Tx2 / Rx3 antenna		Rx4 antenna	
	Horizontal (dBi)	Vertical (dBi)	Horizontal (dBi)	Vertical (dBi)
1710	-2.13	-2.73		
1732.5	-2.66	-2.72		
1747.5	-2.29	-1.97		
1755	-2.21	-1.75		
1785	-2.34	-4.25		
1805	-2.17	-4.78	-4.33	-2.41
1850	-2.56	-2.53	-4.11	-2.64
1880	-0.81	-1.18	-3.44	-2.49
1910	-0.45	-0.46	-2.26	-2.07
1920	-1.02	-0.34	-2.08	-2.07
1950	-3.18	-2.27	-1.75	-2.10
1980	-1.40	-3.57	-1.83	-2.32
2110	-2.55	-2.63	-2.06	-3.05
2200	-0.91	-1.49	-1.54	-3.29
2300	0.33	-2.63	-0.16	-2.31
2305	0.02	-2.78	-0.29	-2.46
2315	-0.77	-3.07	-0.54	-2.83
2350	-2.09	-3.36	-1.19	-3.95
2400	-1.96	-2.92	-0.88	-3.94
2500	-1.82	0.06	-0.65	-3.29
2570	-2.96	0.27	-0.63	-3.87
2595	-3.67	-0.62	-0.78	-4.44
2620	-4.33	-1.82	-0.86	-4.20
2690	-5.59	-4.61	-0.40	-3.31
3400	-3.28	-0.16	-3.30	-4.75
3500	-2.75	0.41	-3.04	-4.46
3600	-2.59	-1.01	-4.29	-3.26
3700	-1.87	-1.31	-3.89	-3.94
3800	-0.49	-1.62	-3.25	-2.62
4200	-2.75	-4.86	-2.88	-0.18
4400	-0.68	-2.67	-3.48	-0.12
4700	-1.40	-2.31	-2.49	0.17
5000	-2.61	-2.03	-1.72	-0.34

Section 2. Dimensioned Photos or Drawings of Antennas

Include a dimensioned photo and dimensioned drawing of Main antenna here.

Tx1/ Rx1 Antenna Dimensioned Drawing:

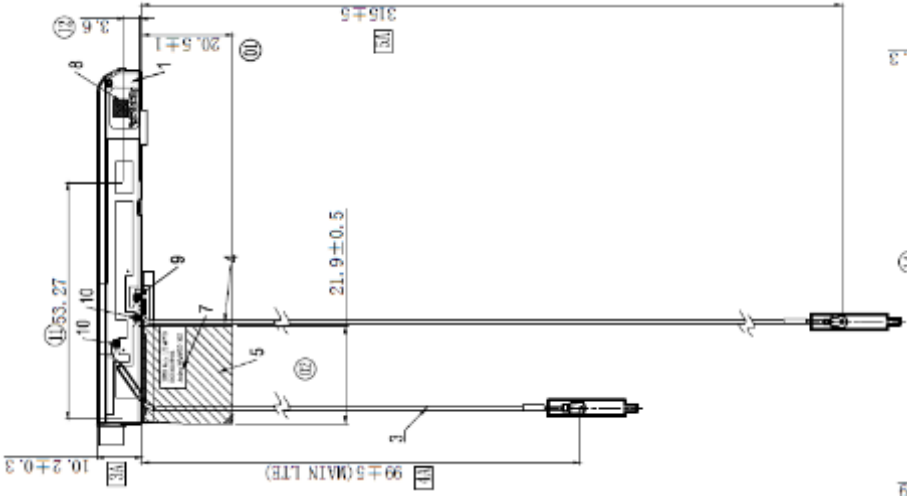

Include a dimensioned photo and dimensioned drawing of Aux antenna here.

Rx2 Antenna Dimensioned Drawing:

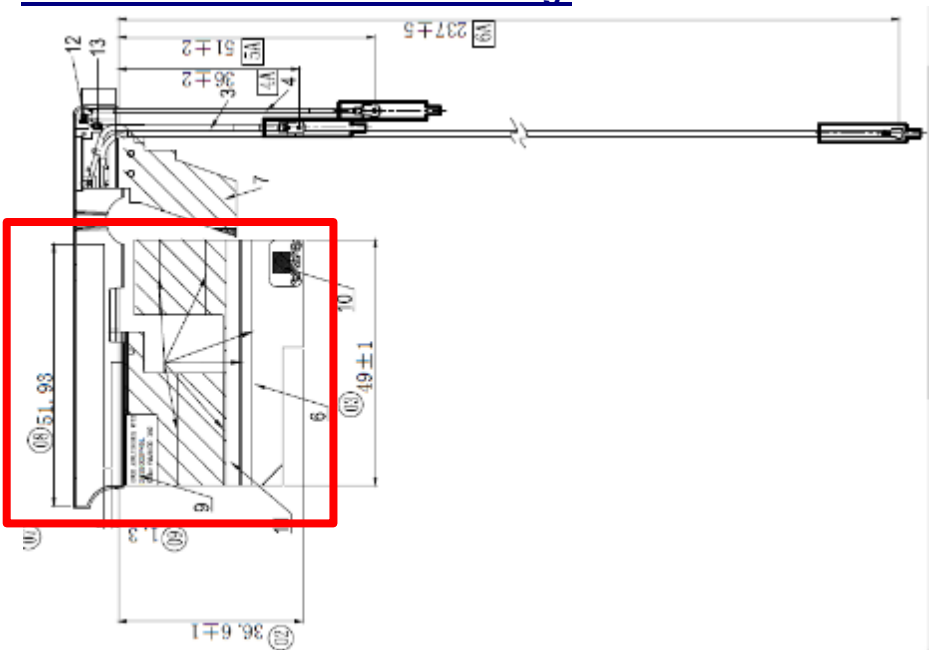

Include front view photo of all 2 antennas here.

Section 3. Radiation characteristics of antennae Loaded in Host Platform

WWAN Main Antenna (TPx)

698MHz

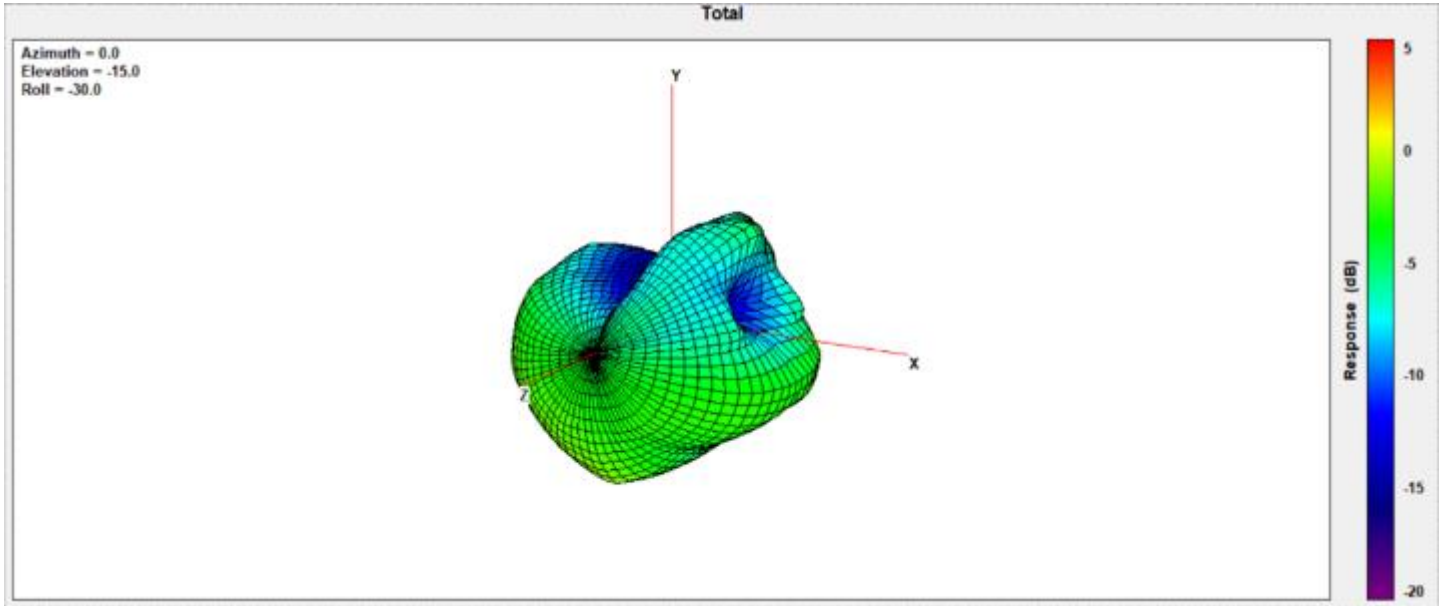

Center Frequency	698 MHz
Horizontal (dBi) peak	-4.21
Vertical (dBi) peak	-1.76

703MHz

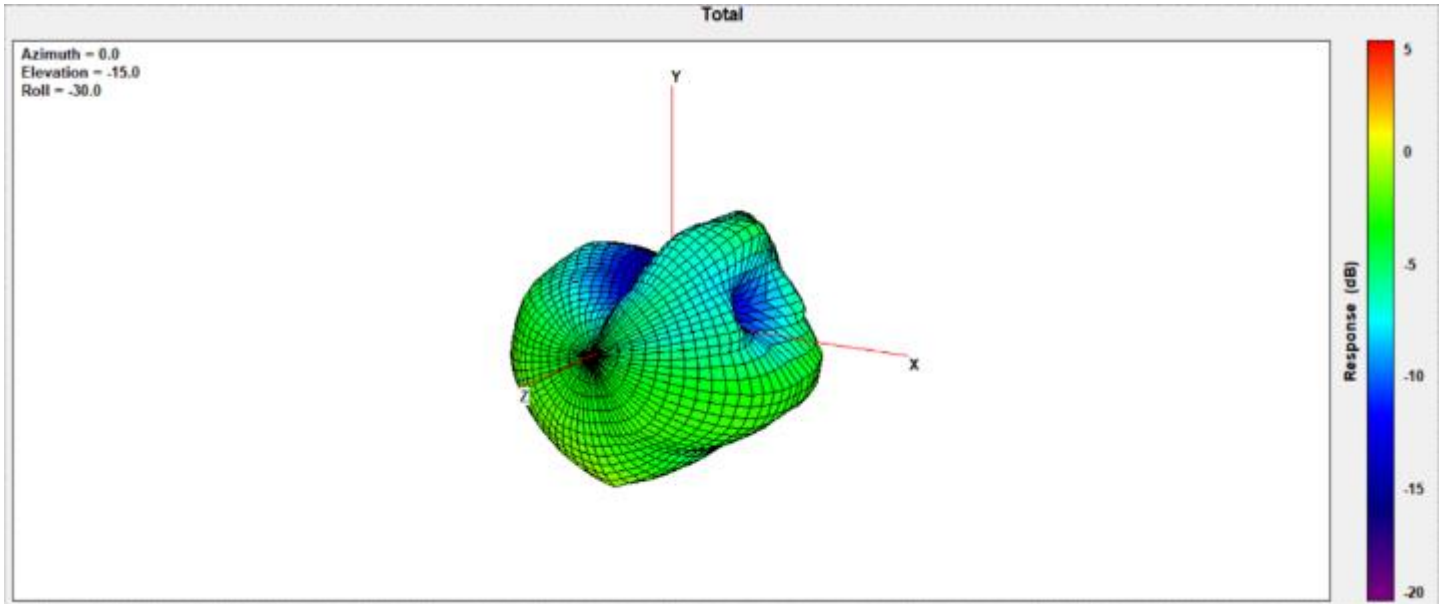

Center Frequency	703MHz
Horizontal (dBi) peak	-3.95
Vertical (dBi) peak	-1.71

707.5MHz

Total

Azimuth = 0.0
Elevation = -15.0
Roll = -30.0

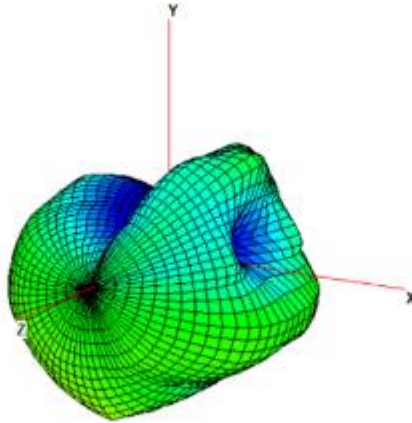

Center Frequency	707.5MHz
Horizontal (dBi) peak	-3.82
Vertical (dBi) peak	-1.76

717MHz

Total

Azimuth = 0.0
Elevation = -15.0
Roll = -30.0

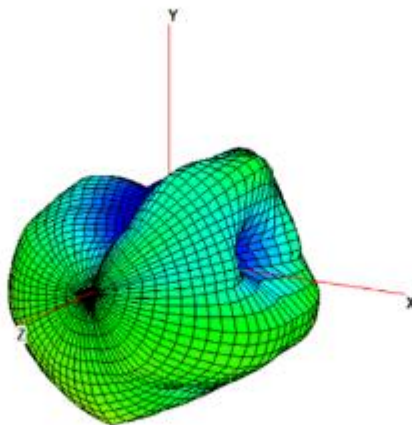

Center Frequency	717MHz
Horizontal (dBi) peak	-3.32
Vertical (dBi) peak	-1.79

725.5MHz

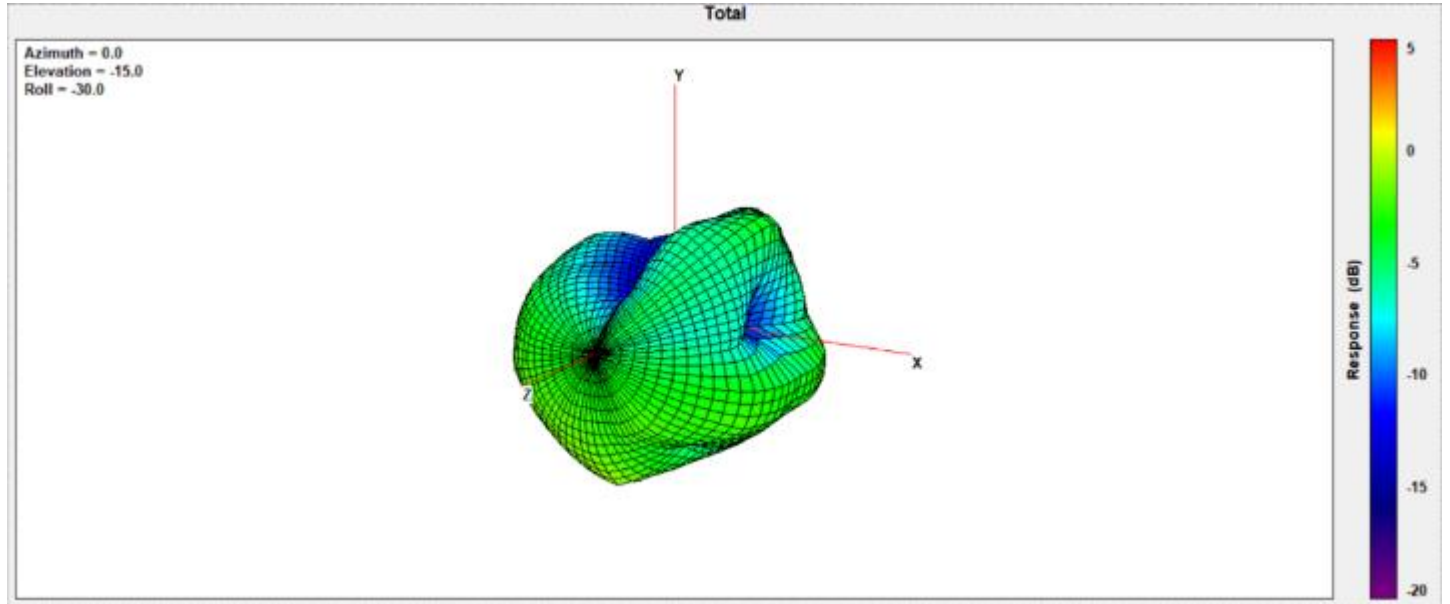

Center Frequency	725.5MHz
Horizontal (dBi) peak	-3.18
Vertical (dBi) peak	-1.69

748MHz

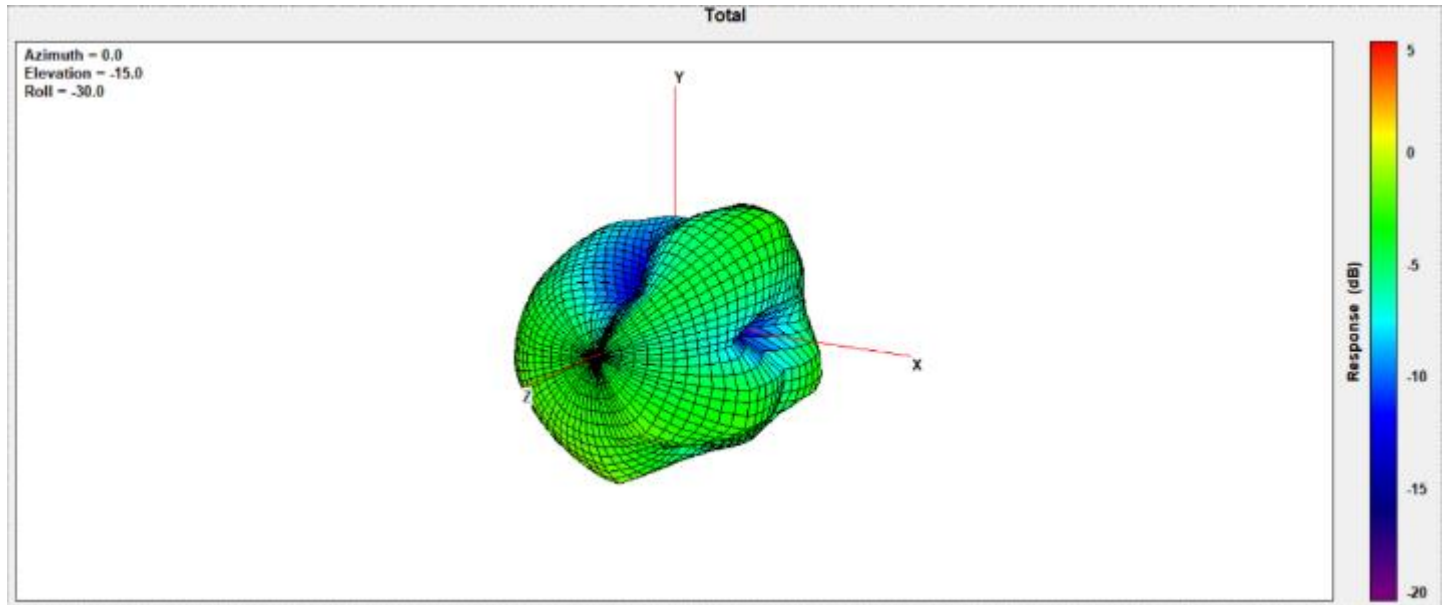

Center Frequency	748MHz
Horizontal (dBi) peak	-3.16
Vertical (dBi) peak	-2.27

756MHz

Total

Azimuth = 0.0
Elevation = -15.0
Roll = -30.0

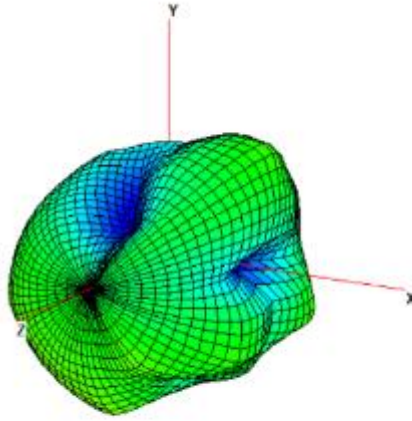

Center Frequency	756MHz
Horizontal (dBi) peak	-3.21
Vertical (dBi) peak	-2.06

768MHz

Total

Azimuth = 0.0
Elevation = -15.0
Roll = -30.0

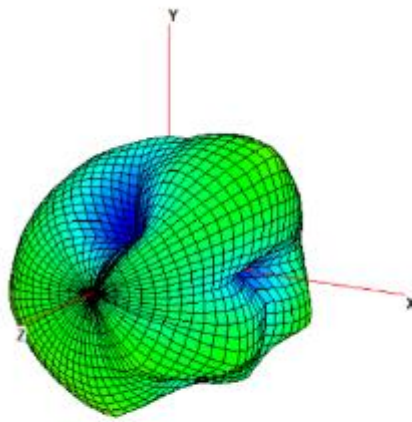

Center Frequency	768MHz
Horizontal (dBi) peak	-3.06
Vertical (dBi) peak	-1.96

777MHz

Total

Azimuth = 0.0
Elevation = -15.0
Roll = -30.0

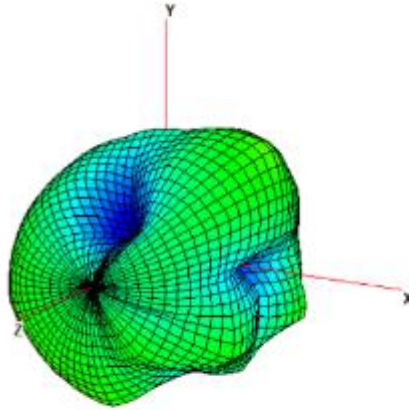

Center Frequency	777MHz
Horizontal (dBi) peak	-3.23
Vertical (dBi) peak	-1.94

782MHz

Total

Azimuth = 0.0
Elevation = -15.0
Roll = -30.0

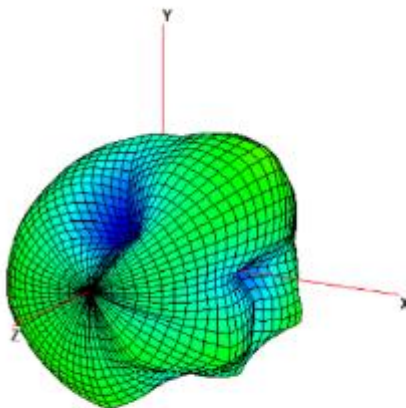

Center Frequency	782MHz
Horizontal (dBi) peak	-3.36
Vertical (dBi) peak	-1.94

787MHz

Total

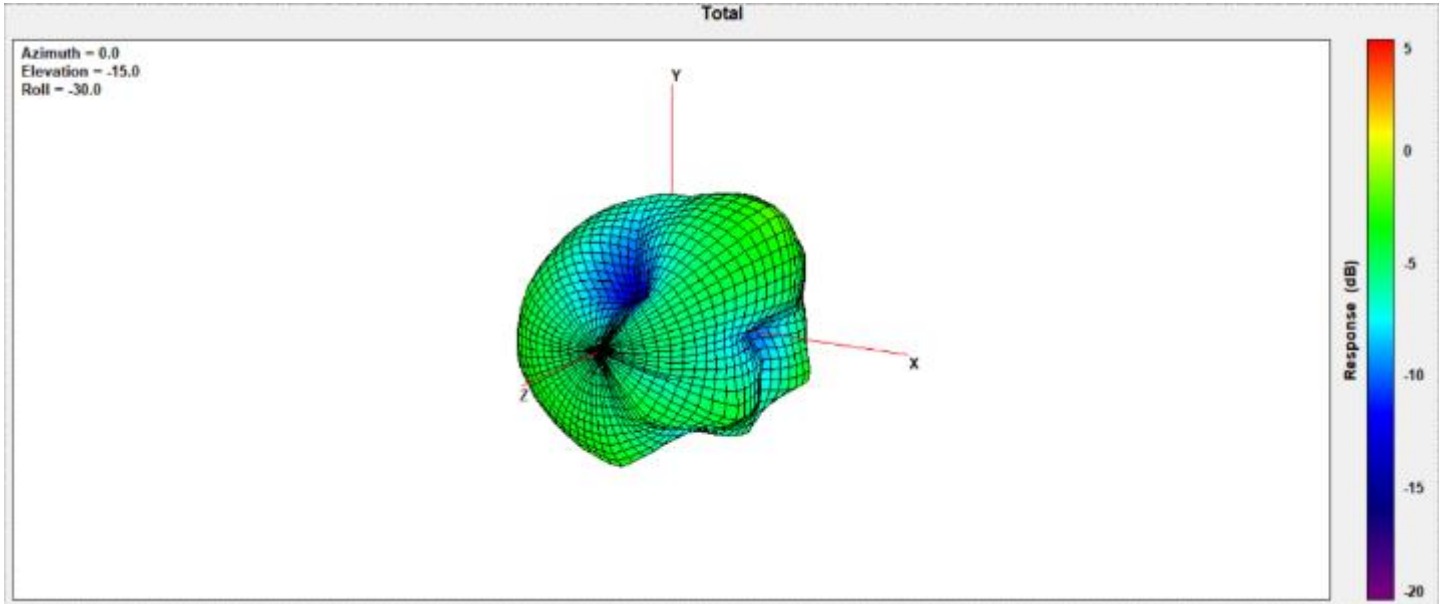

Center Frequency	787MHz
Horizontal (dBi) peak	-3.49
Vertical (dBi) peak	-1.92

814MHz

Total

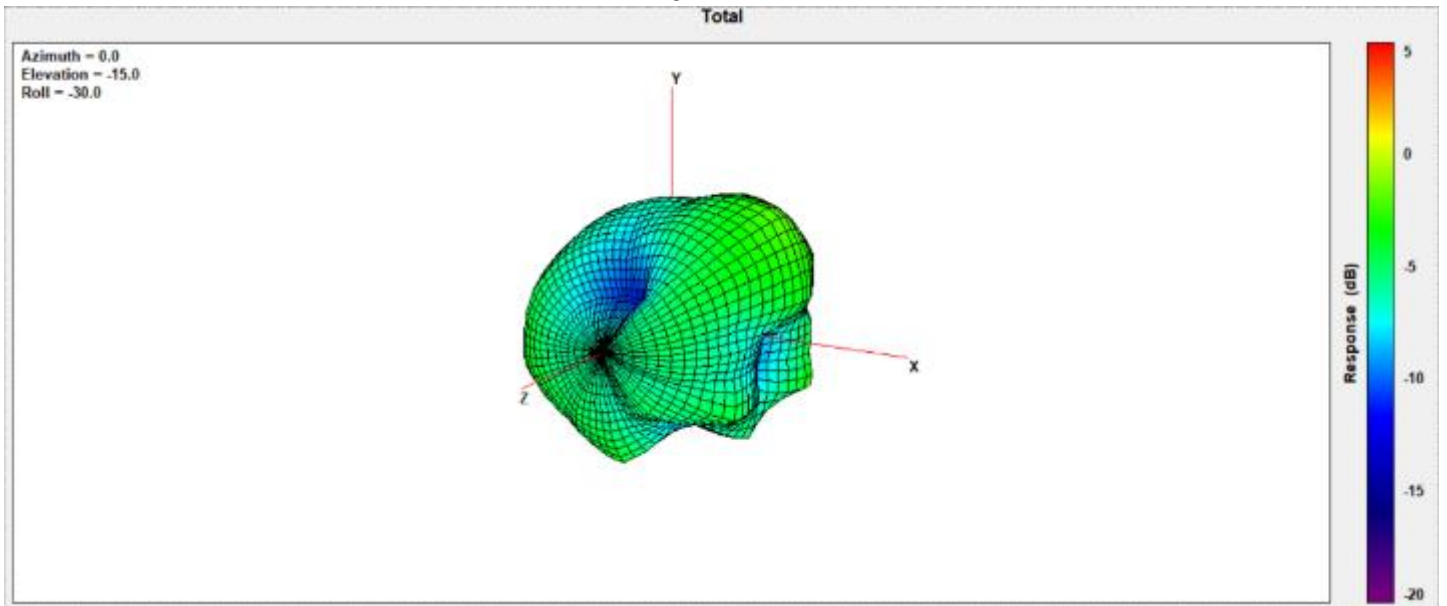

Center Frequency	814MHz
Horizontal (dBi) peak	-3.63
Vertical (dBi) peak	-1.80

824MHz

Total

Azimuth = 0.0
Elevation = -15.0
Roll = -30.0

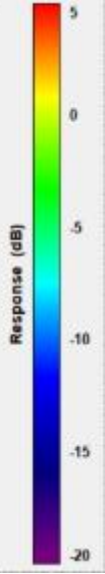
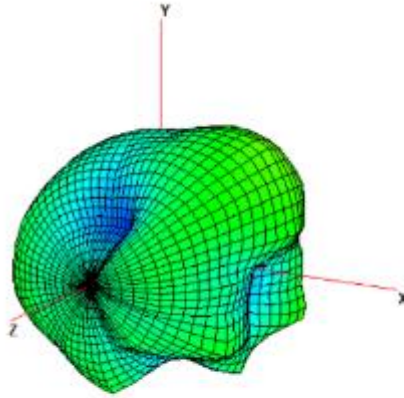

Center Frequency	824MHz
Horizontal (dBi) peak	-3.28
Vertical (dBi) peak	-1.78

832MHz

Total

Azimuth = 0.0
Elevation = -15.0
Roll = -30.0

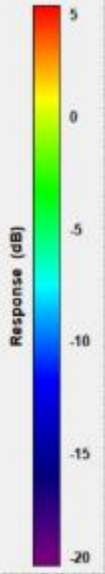
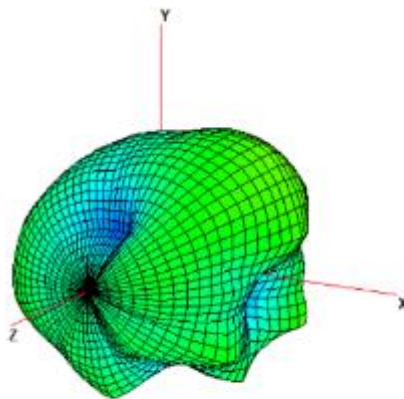

Center Frequency	832MHz
Horizontal (dBi) peak	-3.07
Vertical (dBi) peak	-1.75

836.5MHz

Total

Azimuth = 0.0
Elevation = -15.0
Roll = -30.0

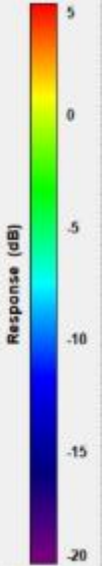
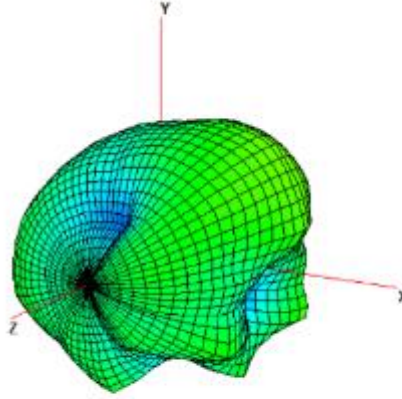

Center Frequency	836.5MHz
Horizontal (dBi) peak	-2.95
Vertical (dBi) peak	-1.61

849MHz

Total

Azimuth = 0.0
Elevation = -15.0
Roll = -30.0

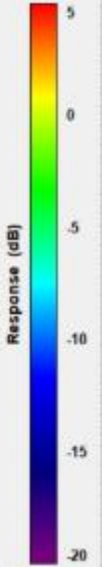
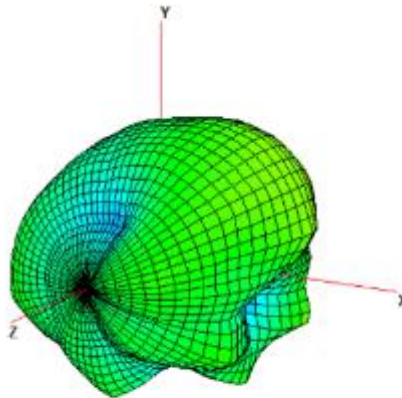

Center Frequency	849MHz
Horizontal (dBi) peak	-2.48
Vertical (dBi) peak	-1.17

862MHz

Total

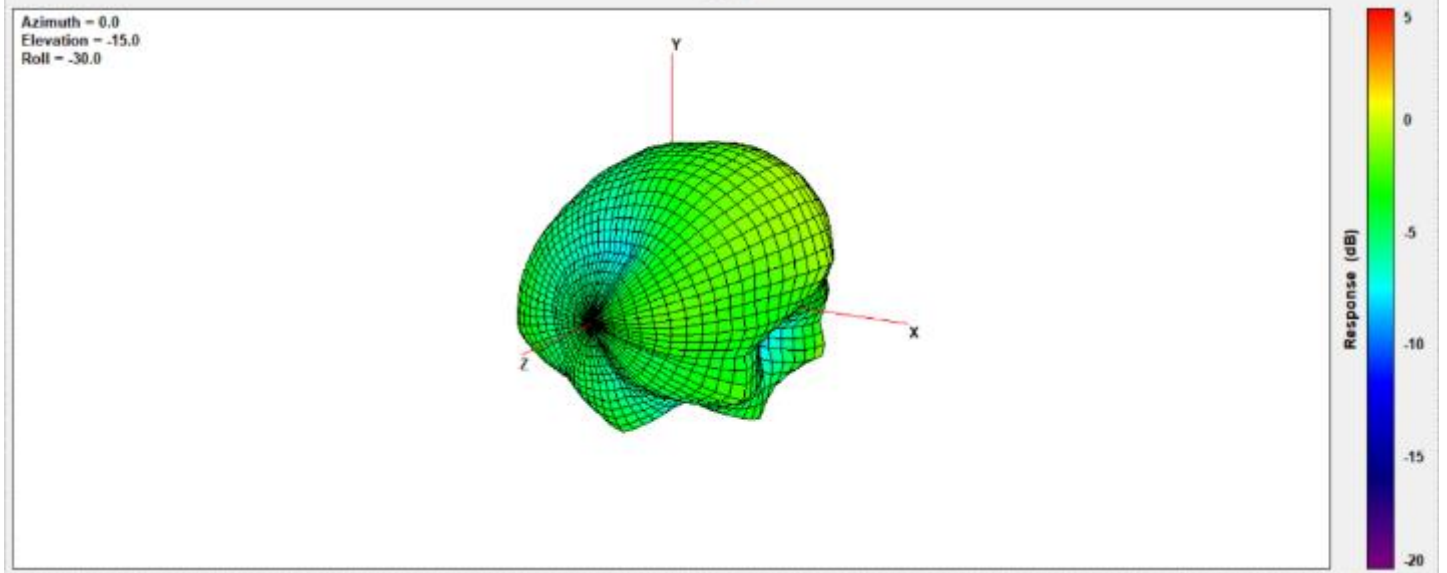

Center Frequency	862MHz
Horizontal (dBi) peak	-1.76
Vertical (dBi) peak	-0.58

880MHz

Total

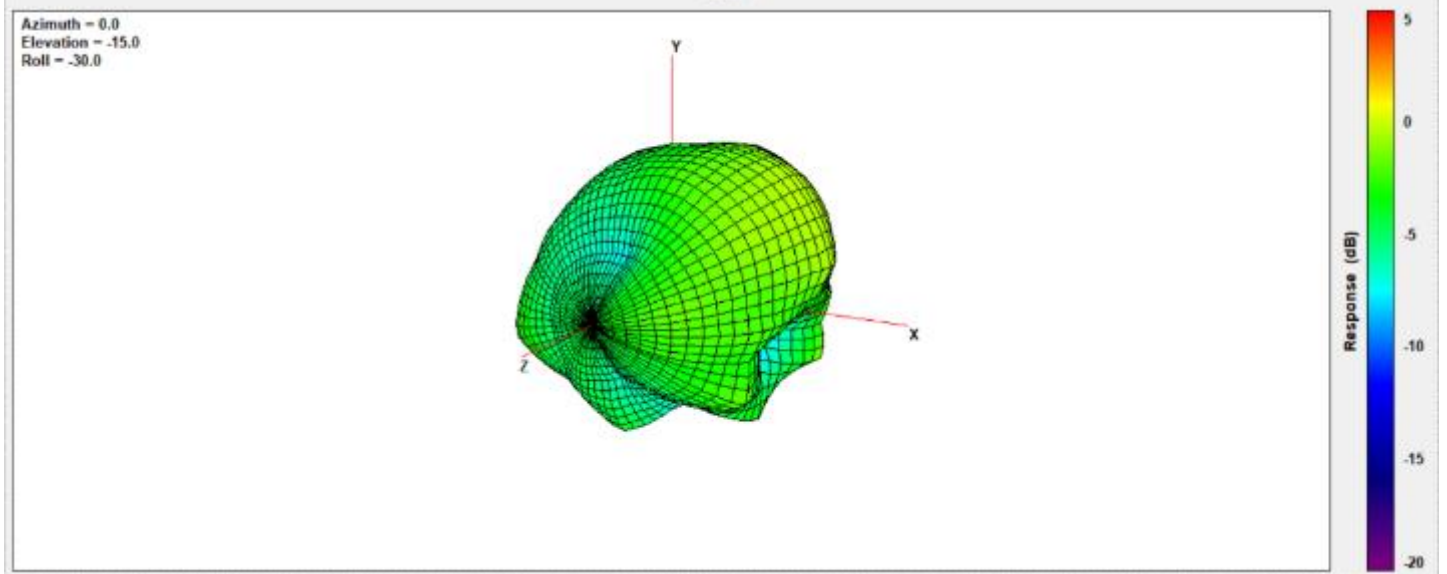

Center Frequency	880MHz
Horizontal (dBi) peak	-1.54
Vertical (dBi) peak	-0.42

897.5MHz

Total

Azimuth = 0.0
Elevation = -15.0
Roll = -30.0

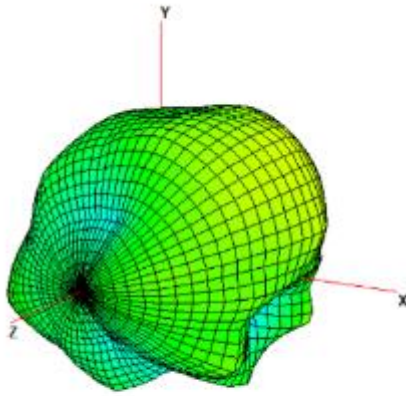

Center Frequency	897.5MHz
Horizontal (dBi) peak	-1.67
Vertical (dBi) peak	0.10

915MHz

Total

Azimuth = 0.0
Elevation = -15.0
Roll = -30.0

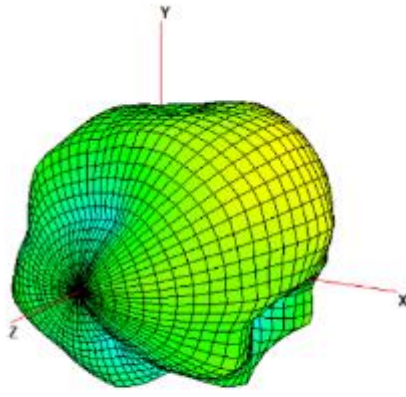

Center Frequency	915MHz
Horizontal (dBi) peak	-1.22
Vertical (dBi) peak	-0.12

925MHz

Total

Azimuth = 0.0
Elevation = -15.0
Roll = -30.0

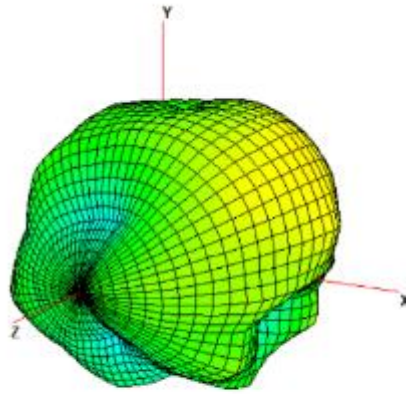

Center Frequency	925MHz
Horizontal (dBi) peak	-0.89
Vertical (dBi) peak	-0.34

960MHz

Total

Azimuth = 0.0
Elevation = -15.0
Roll = -30.0

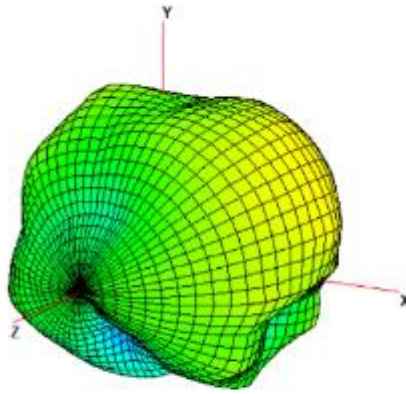

Center Frequency	960MHz
Horizontal (dBi) peak	-4.23
Vertical (dBi) peak	-1.79

1427.9MHz

Total

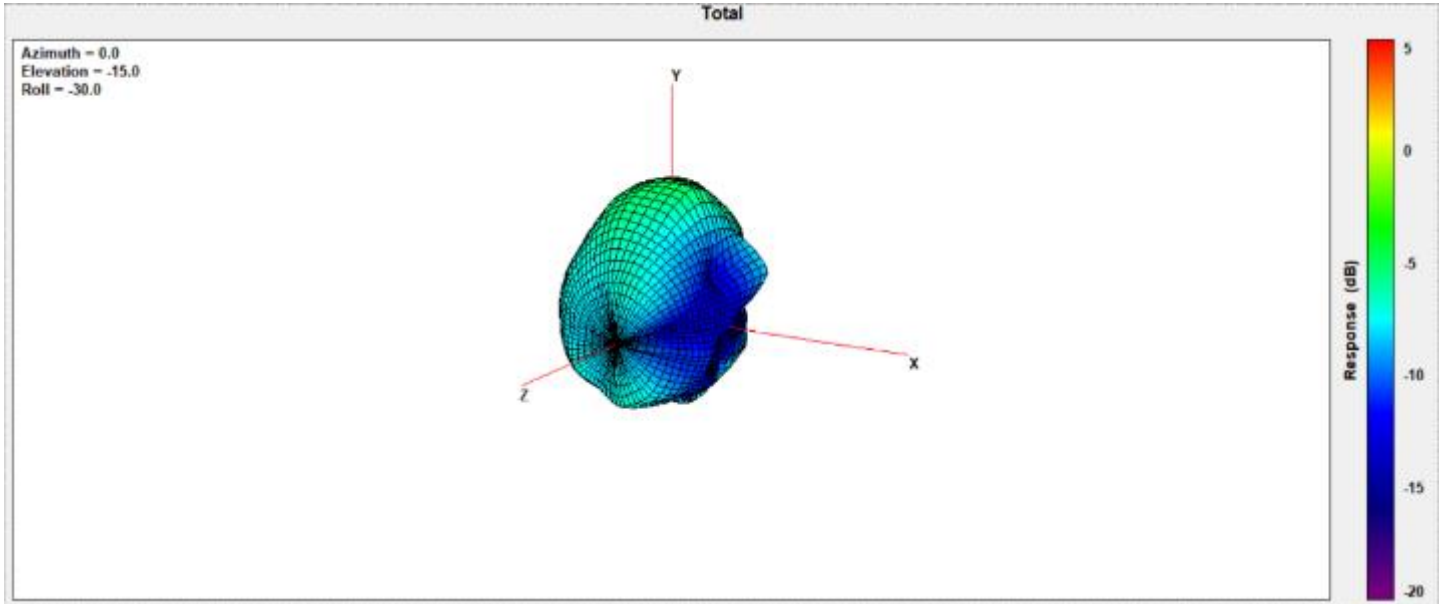

Center Frequency	1427.9MHz
Horizontal (dBi) peak	-6.51
Vertical (dBi) peak	-3.49

1447.9MHz

Total

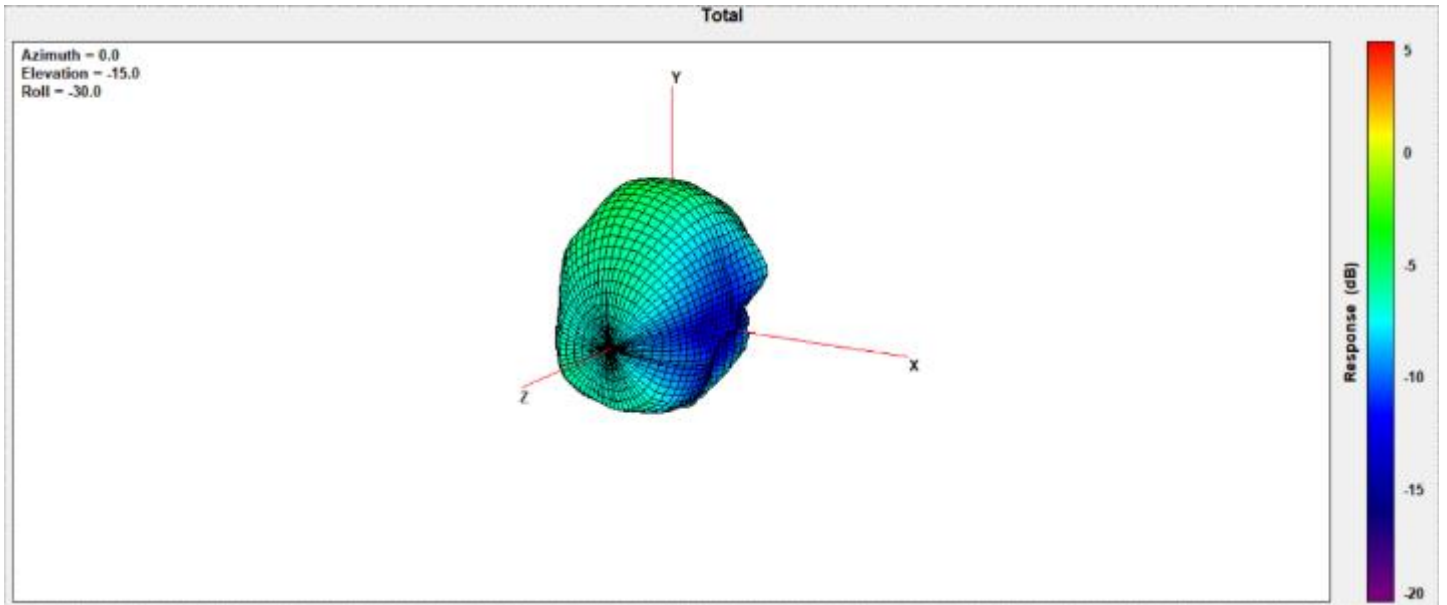

Center Frequency	1447.9MHz
Horizontal (dBi) peak	-4.29
Vertical (dBi) peak	-3.10

1455.4MHz

Total

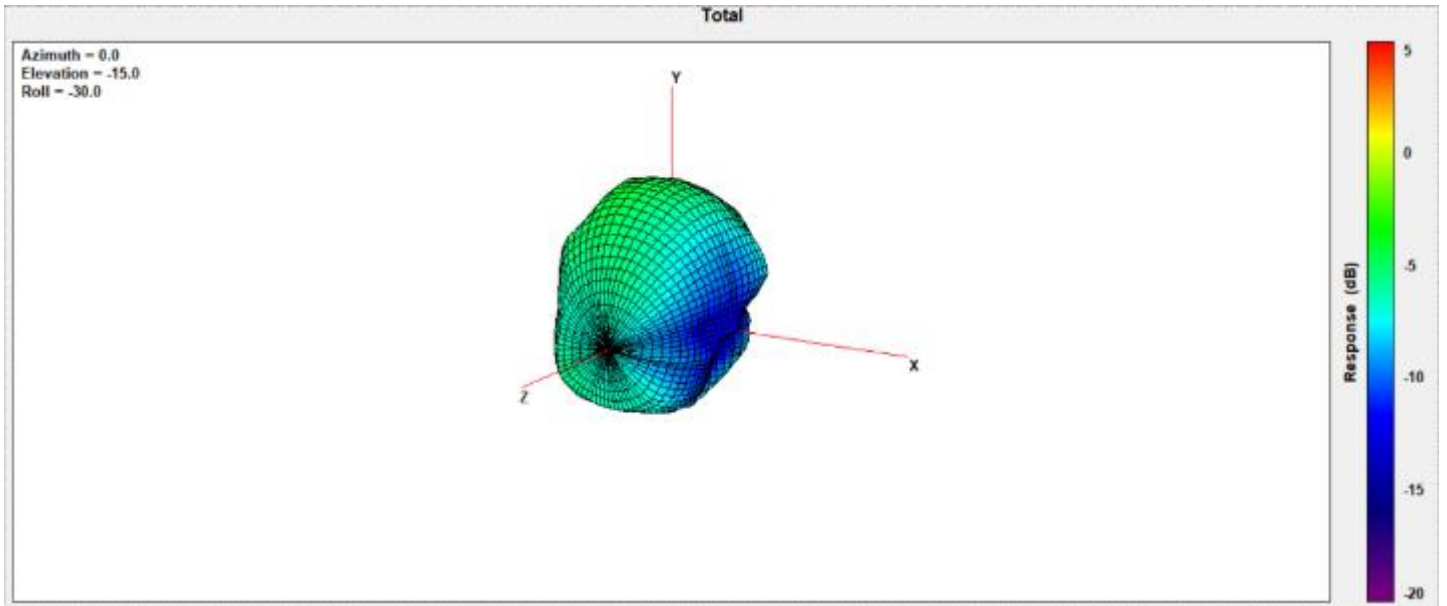

Center Frequency	1455.4MHz
Horizontal (dBi) peak	-4.21
Vertical (dBi) peak	-2.91

1462.9MHz

Total

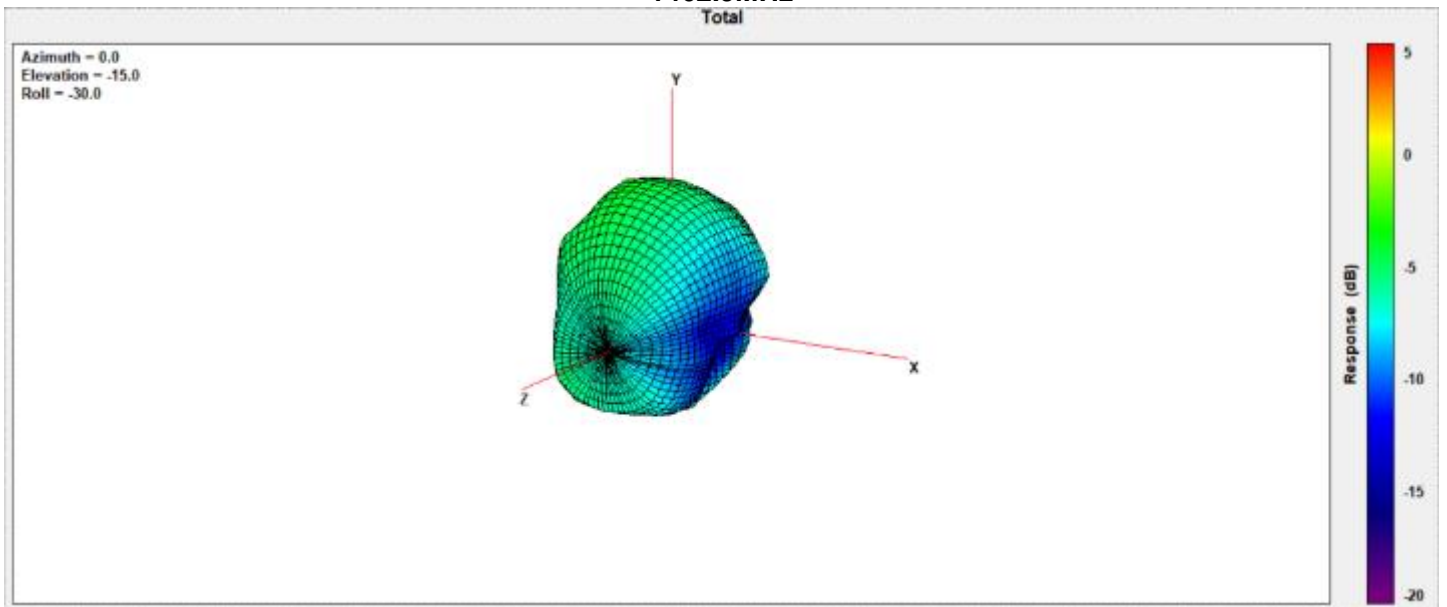

Center Frequency	1462.9MHz
Horizontal (dBi) peak	-4.14
Vertical (dBi) peak	-2.69

1496MHz

Total

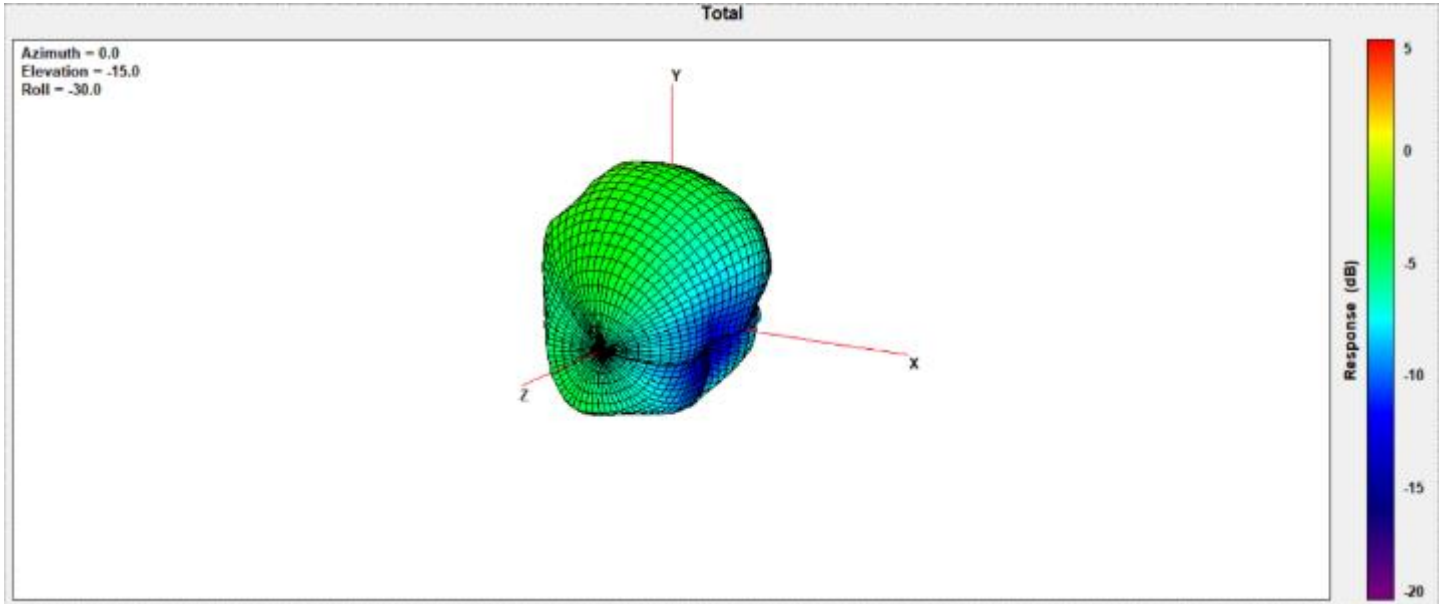

Center Frequency	1496MHz
Horizontal (dBi) peak	-4.06
Vertical (dBi) peak	-1.32

1510.9 MHz

Total

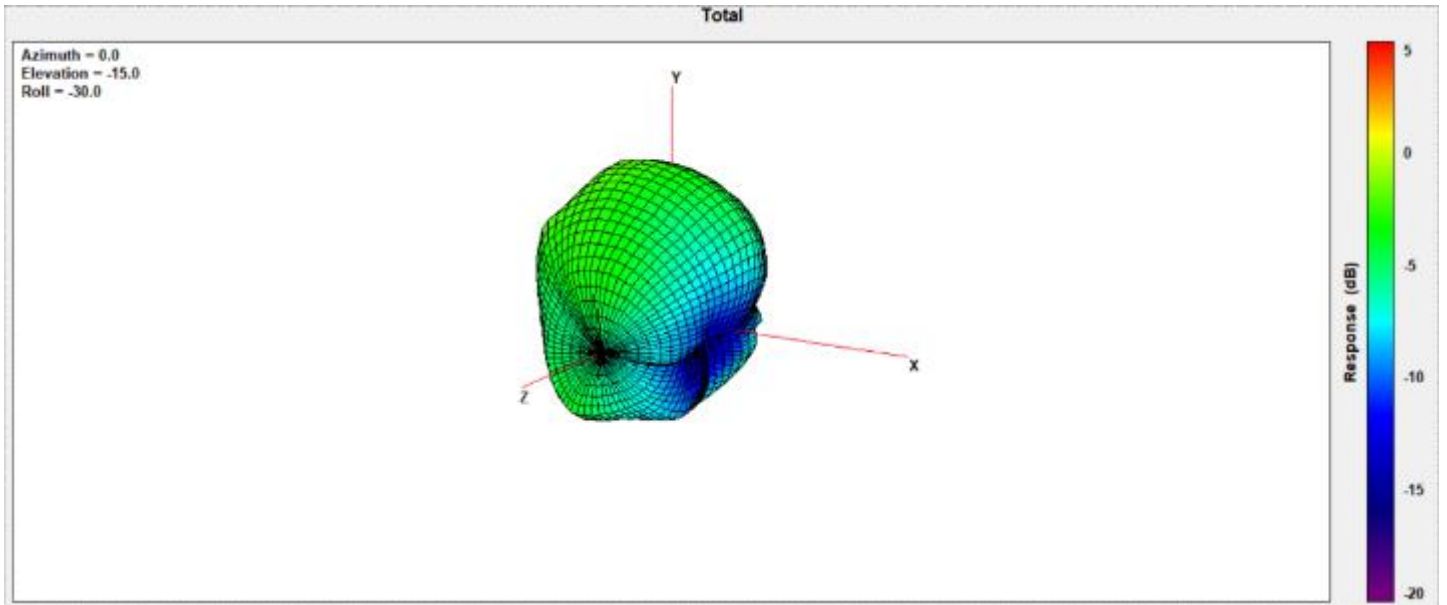

Center Frequency	1510.9 MHz
Horizontal (dBi) peak	-4.03
Vertical (dBi) peak	-0.96

1710 MHz

Total

Azimuth = 0.0
Elevation = -15.0
Roll = -30.0

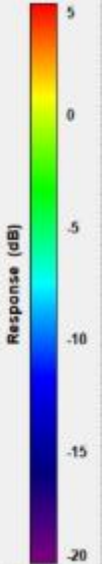
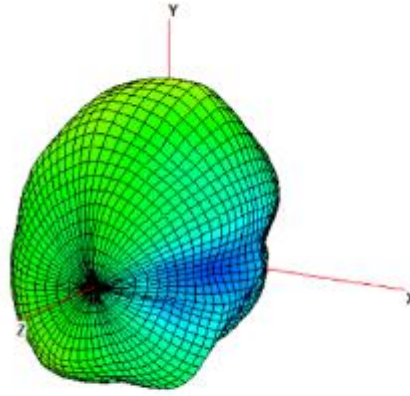

Center Frequency	1710 MHz
Horizontal (dBi) peak	-1.94
Vertical (dBi) peak	-1.05

1732.5 MHz

Total

Azimuth = 0.0
Elevation = -15.0
Roll = -30.0

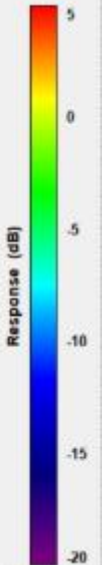
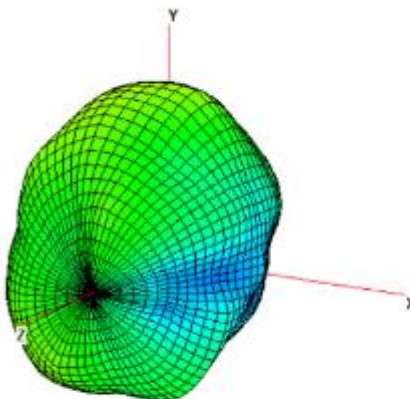

Center Frequency	1732.5 MHz
Horizontal (dBi) peak	-1.86
Vertical (dBi) peak	-0.94

1747.5 MHz

Total

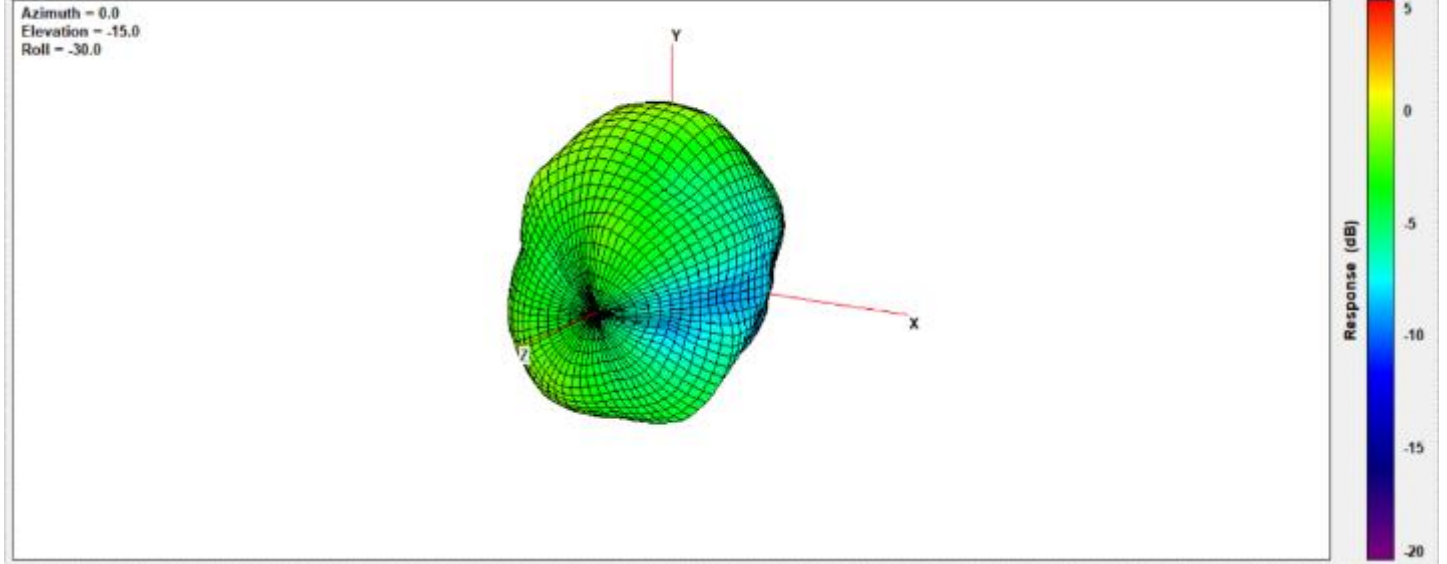

Center Frequency	1747.5 MHz
Horizontal (dBi) peak	-2.12
Vertical (dBi) peak	-1.15

1755 MHz

Total

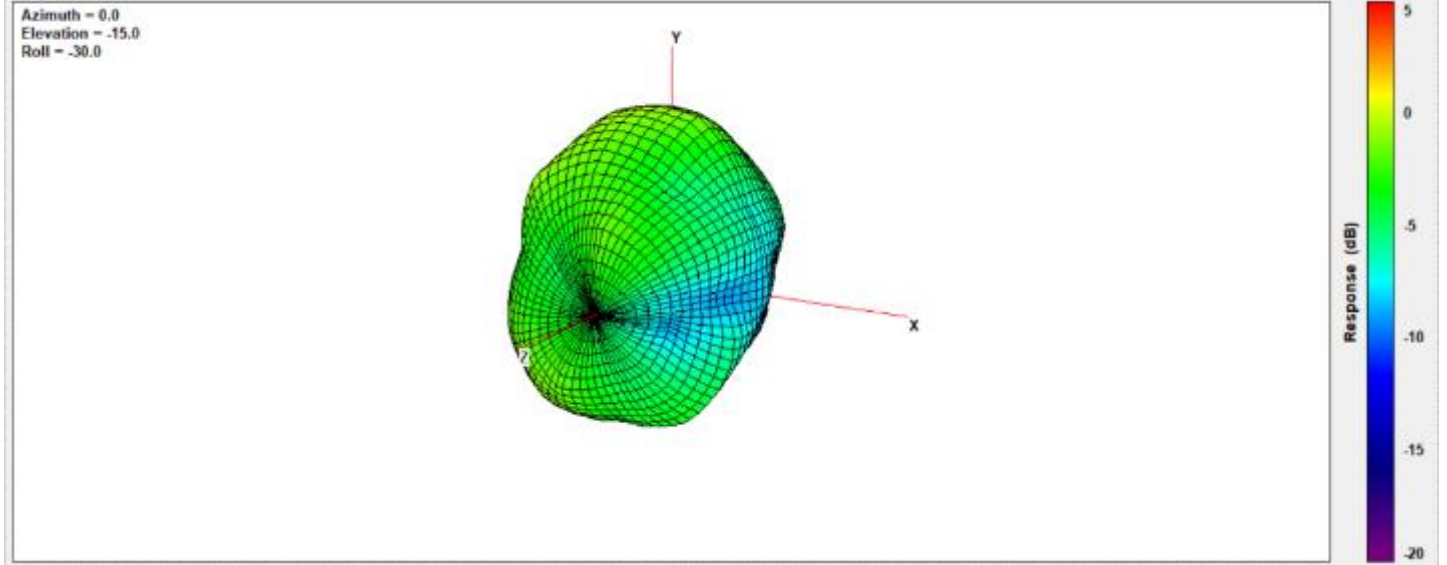

Center Frequency	1755 MHz
Horizontal (dBi) peak	-2.29
Vertical (dBi) peak	-1.33

1785 MHz

Total

Azimuth = 0.0
Elevation = -15.0
Roll = -30.0

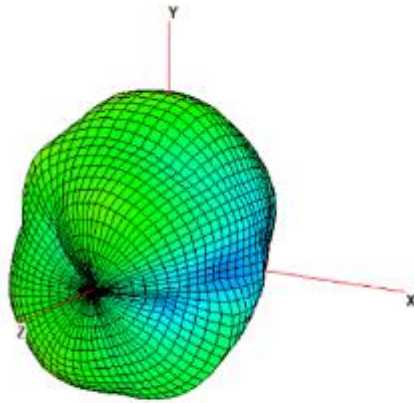

Center Frequency	1785 MHz
Horizontal (dBi) peak	-3.33
Vertical (dBi) peak	-1.06

1805 MHz

Total

Azimuth = 0.0
Elevation = -15.0
Roll = -30.0

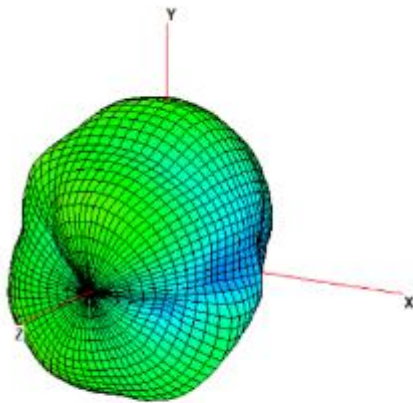

Center Frequency	1805 MHz
Horizontal (dBi) peak	-3.58
Vertical (dBi) peak	-1.32

1850 MHz

Total

Azimuth = 0.0
Elevation = -15.0
Roll = -30.0

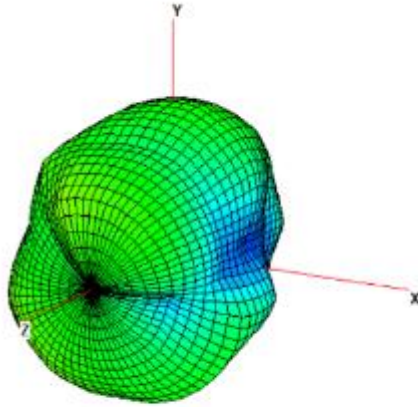

Center Frequency	1850 MHz
Horizontal (dBi) peak	-2.84
Vertical (dBi) peak	-1.33

1880 MHz

Total

Azimuth = 0.0
Elevation = -15.0
Roll = -30.0

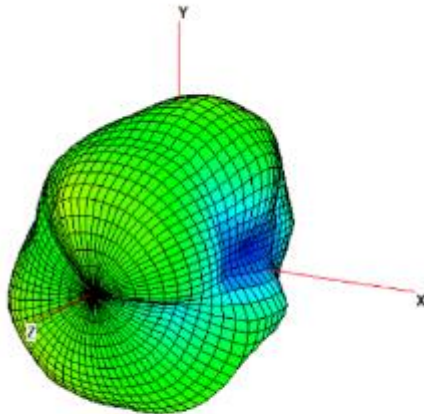

Center Frequency	1880 MHz
Horizontal (dBi) peak	-1.88
Vertical (dBi) peak	-0.90

1910MHz

Total

Azimuth = 0.0
Elevation = -15.0
Roll = -30.0

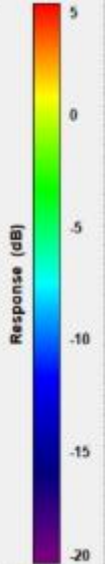
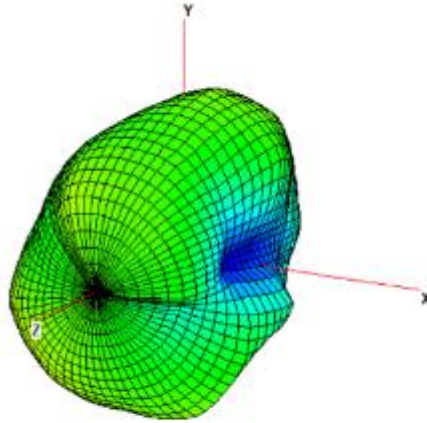

Center Frequency	1910MHz
Horizontal (dBi) peak	-1.57
Vertical (dBi) peak	-0.95

1920MHz

Total

Azimuth = 0.0
Elevation = -15.0
Roll = -30.0

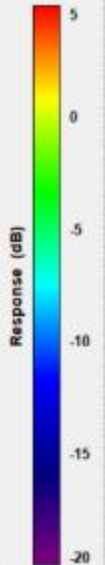
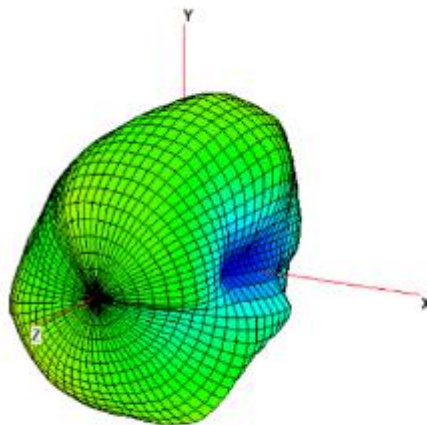

Center Frequency	1920MHz
Horizontal (dBi) peak	-1.66
Vertical (dBi) peak	-0.84

1950MHz

Total

Azimuth = 0.0
Elevation = -15.0
Roll = -30.0

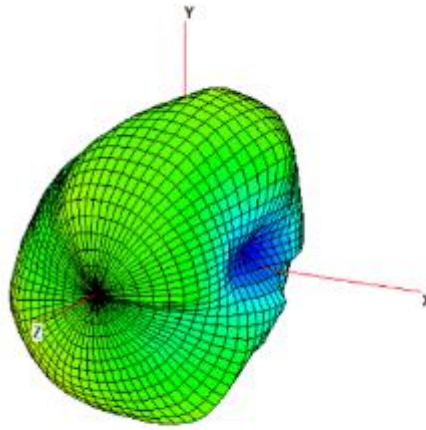

Center Frequency	1950MHz
Horizontal (dBi) peak	-1.65
Vertical (dBi) peak	-0.64

1980MHz

Total

Azimuth = 0.0
Elevation = -15.0
Roll = -30.0

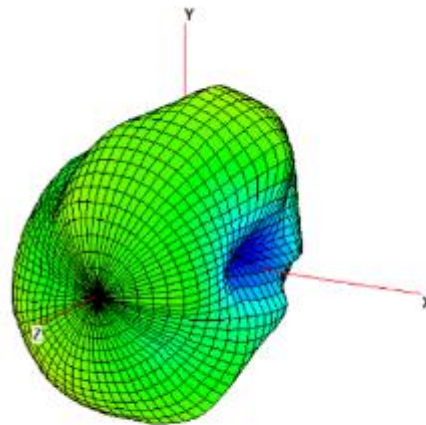

Center Frequency	1980MHz
Horizontal (dBi) peak	-1.53
Vertical (dBi) peak	-0.86

2110MHz

Total

Azimuth = 0.0
Elevation = -15.0
Roll = -30.0

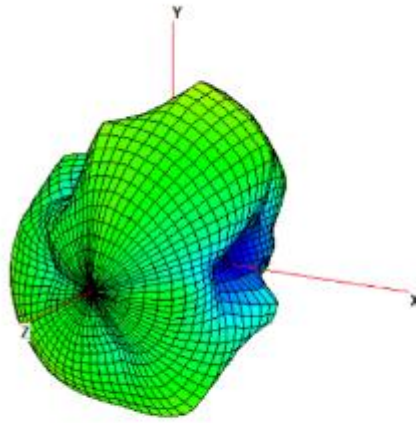

Center Frequency	2110MHz
Horizontal (dBi) peak	-2.27
Vertical (dBi) peak	-1.24

2200MHz

Total

Azimuth = 0.0
Elevation = -15.0
Roll = -30.0

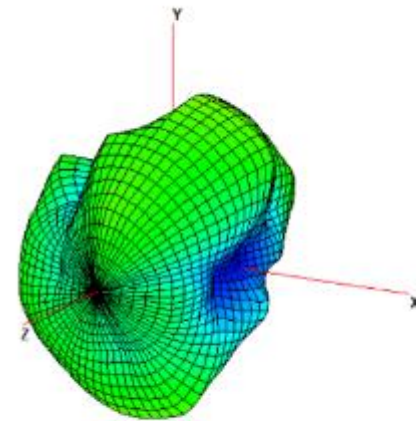

Center Frequency	2200MHz
Horizontal (dBi) peak	-2.08
Vertical (dBi) peak	-2.03

2300MHz

Total

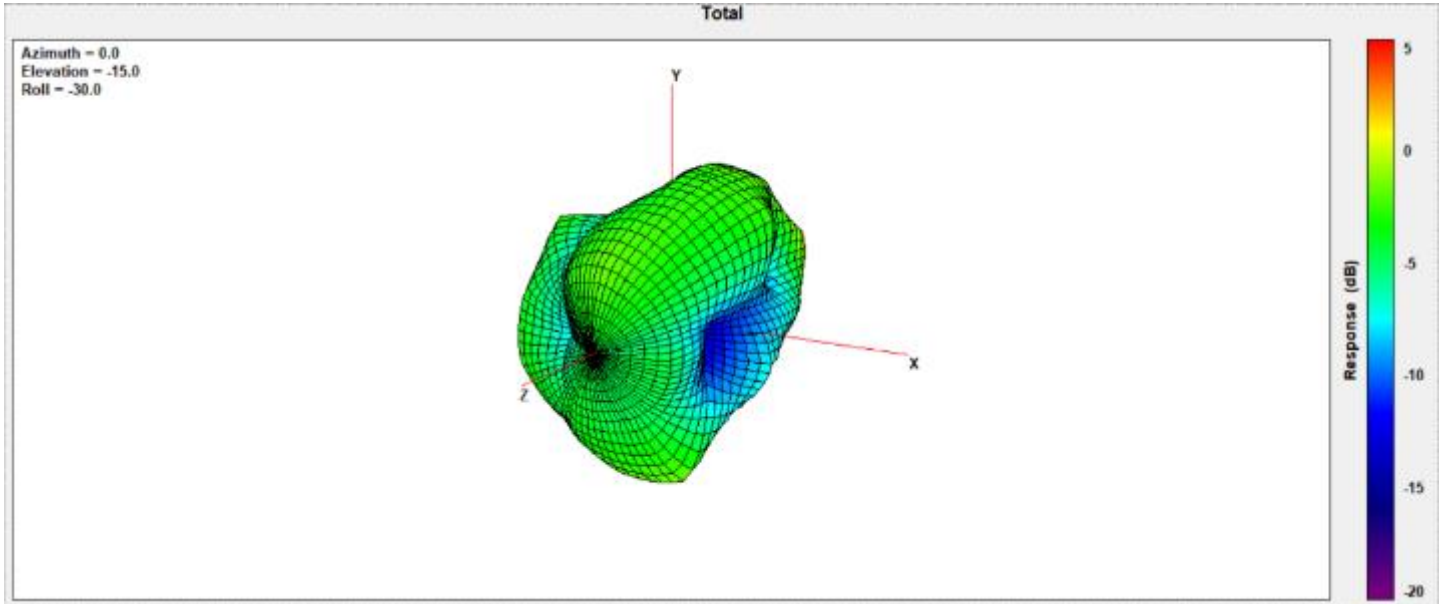

Center Frequency	2300MHz
Horizontal (dBi) peak	-0.81
Vertical (dBi) peak	-1.67

2305MHz

Total

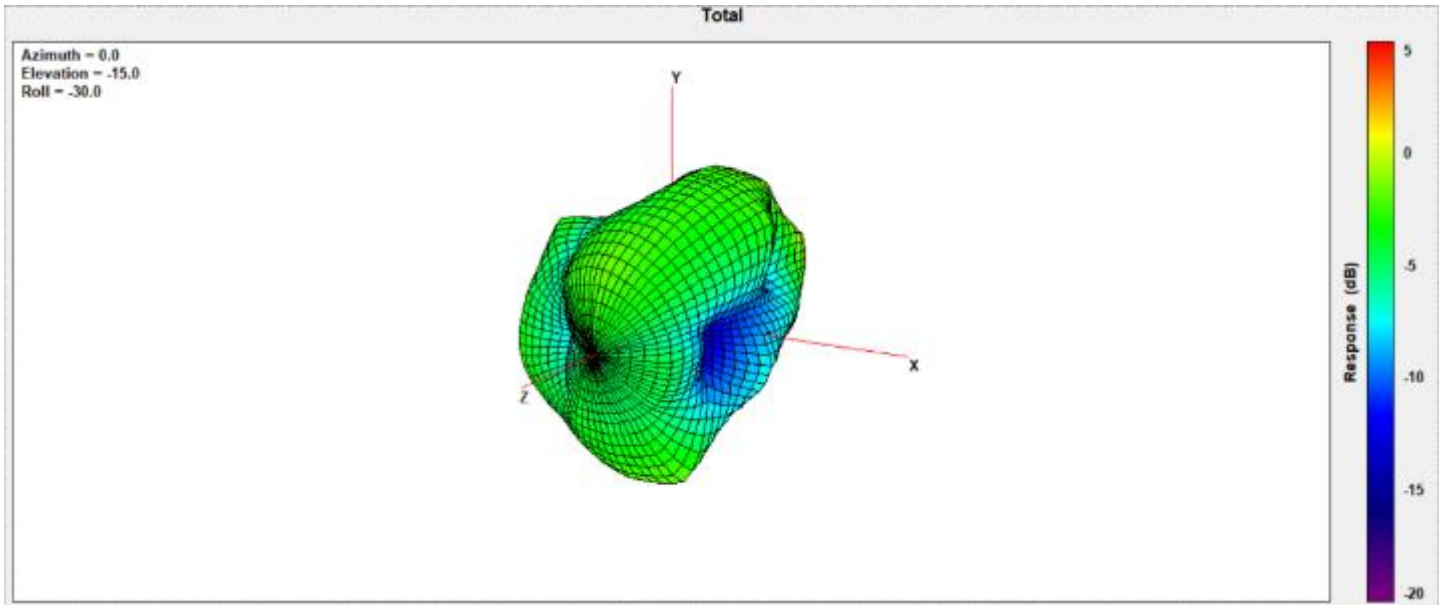

Center Frequency	2305MHz
Horizontal (dBi) peak	-0.91
Vertical (dBi) peak	-1.59

2315MHz

Total

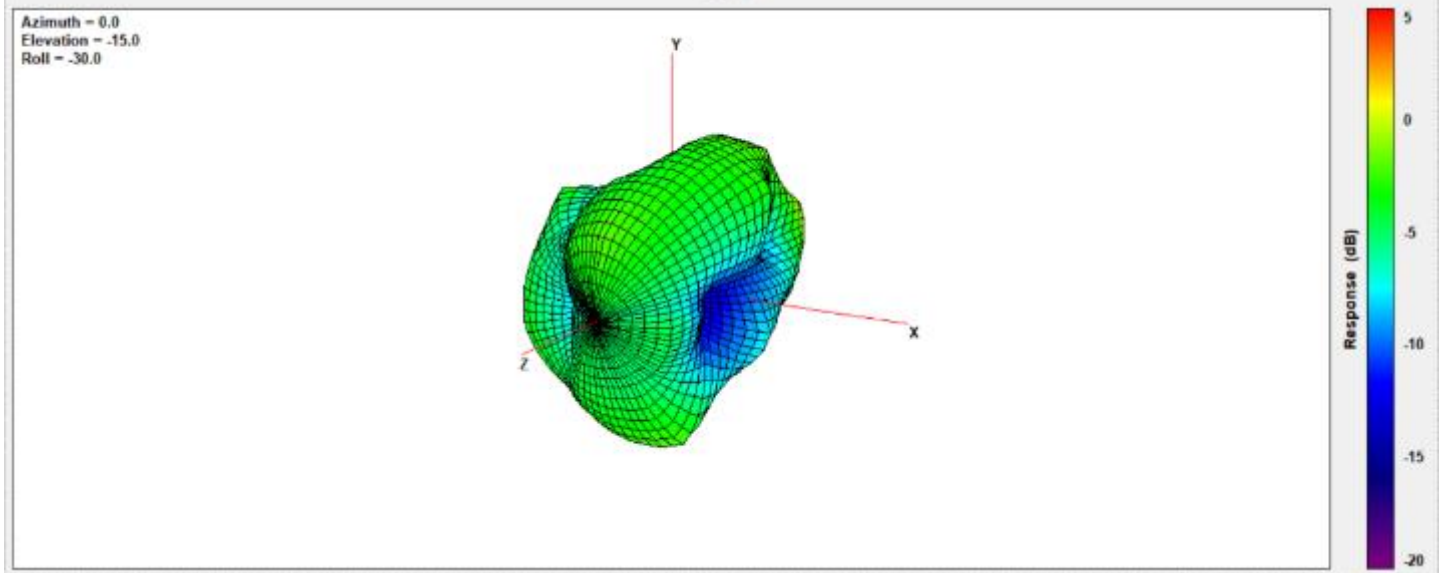

Center Frequency	2315MHz
Horizontal (dBi) peak	-1.41
Vertical (dBi) peak	-1.63

2350MHz

Total

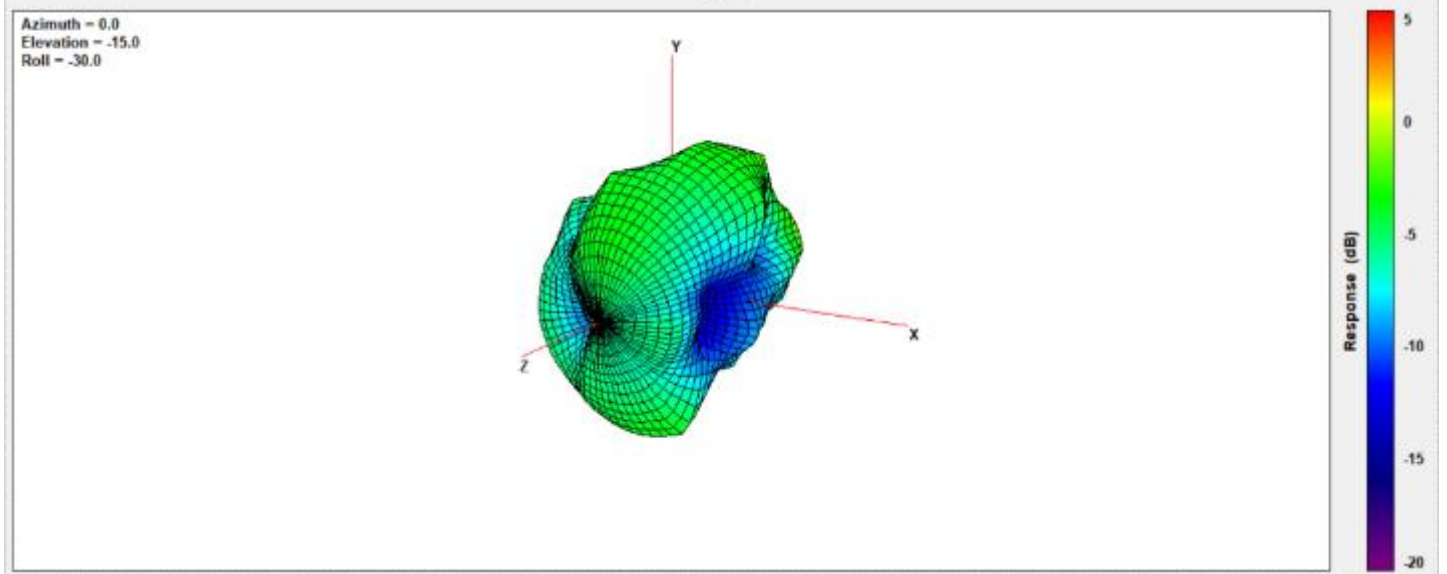

Center Frequency	2350MHz
Horizontal (dBi) peak	-3.50
Vertical (dBi) peak	-2.22

2400MHz

Total

Azimuth = 0.0
Elevation = -15.0
Roll = -30.0

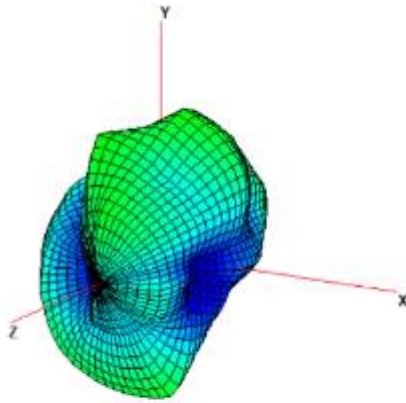

Center Frequency	2400MHz
Horizontal (dBi) peak	-4.12
Vertical (dBi) peak	-4.07

2500MHz

Total

Azimuth = 0.0
Elevation = -15.0
Roll = -30.0

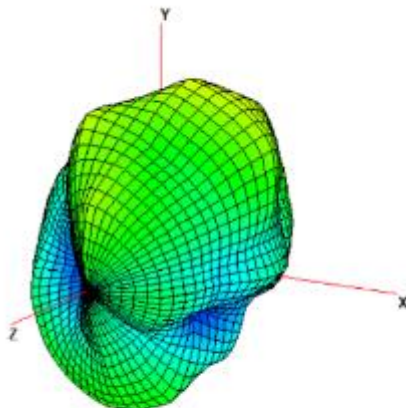

Center Frequency	2500MHz
Horizontal (dBi) peak	-3.72
Vertical (dBi) peak	-0.30

2570MHz

Total

Azimuth = 0.0
Elevation = -15.0
Roll = -30.0

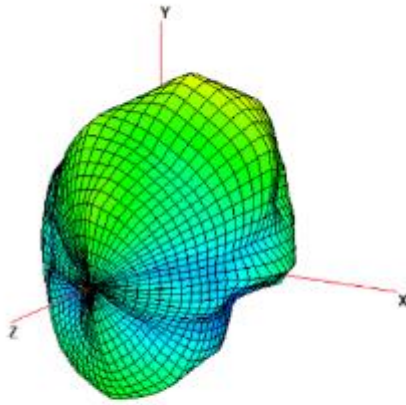

Center Frequency	2570MHz
Horizontal (dBi) peak	-3.99
Vertical (dBi) peak	-1.13

2595MHz

Total

Azimuth = 0.0
Elevation = -15.0
Roll = -30.0

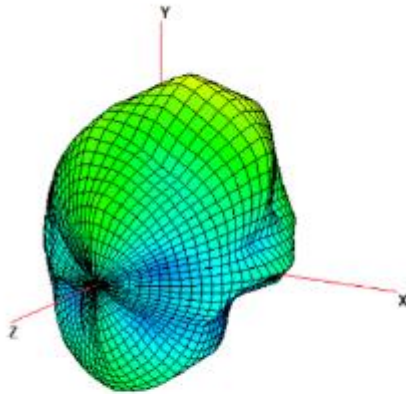

Center Frequency	2595MHz
Horizontal (dBi) peak	-4.76
Vertical (dBi) peak	-1.20

2620MHz

Total

Azimuth = 0.0
Elevation = -15.0
Roll = -30.0

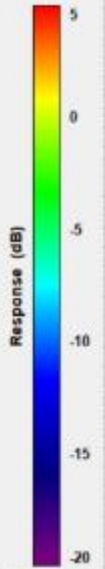
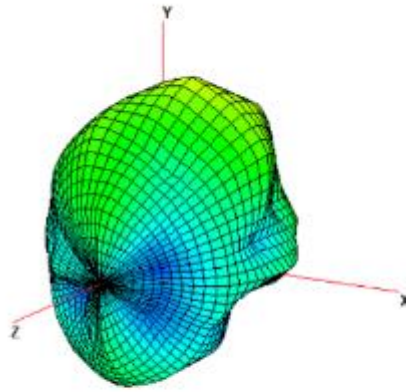

Center Frequency	2620MHz
Horizontal (dBi) peak	-5.07
Vertical (dBi) peak	-1.07

2690MHz

Total

Azimuth = 0.0
Elevation = -15.0
Roll = -30.0

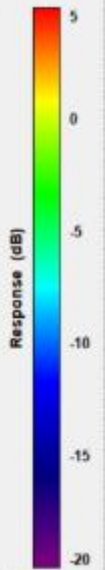
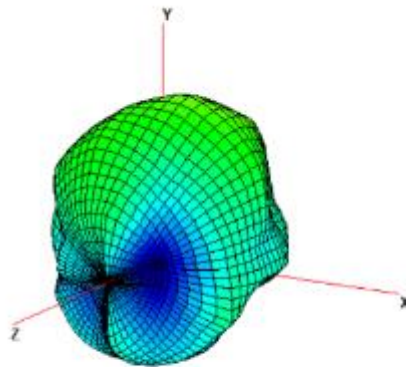

Center Frequency	2690MHz
Horizontal (dBi) peak	-5.35
Vertical (dBi) peak	-3.18

3400MHz

Total

Azimuth = 0.0
Elevation = -15.0
Roll = -30.0

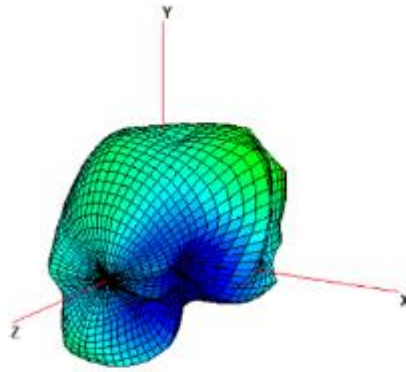

Center Frequency	3400MHz
Horizontal (dBi) peak	-2.11
Vertical (dBi) peak	-3.94

3500MHz

Total

Azimuth = 0.0
Elevation = -15.0
Roll = -30.0

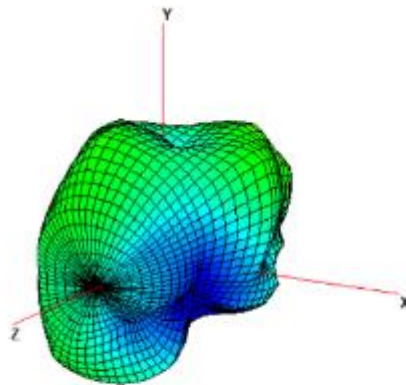

Center Frequency	3500MHz
Horizontal (dBi) peak	-2.01
Vertical (dBi) peak	-4.03

3600MHz

Total

Azimuth = 0.0
Elevation = -15.0
Roll = -30.0

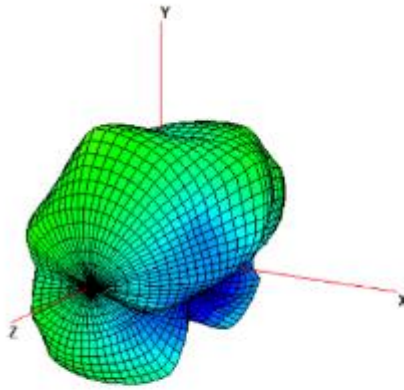

Center Frequency	3600MHz
Horizontal (dBi) peak	-2.39
Vertical (dBi) peak	-4.55

3700MHz

Total

Azimuth = 0.0
Elevation = -15.0
Roll = -30.0

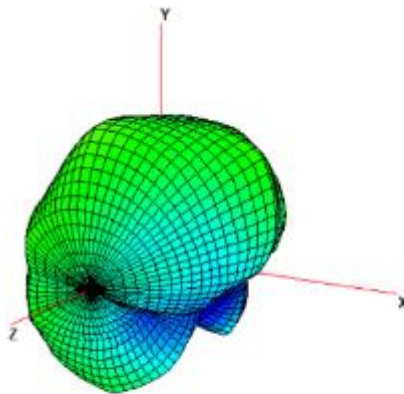

Center Frequency	3700MHz
Horizontal (dBi) peak	-2.81
Vertical (dBi) peak	-4.05

3800MHz

Total

Azimuth = 0.0
Elevation = -15.0
Roll = -30.0

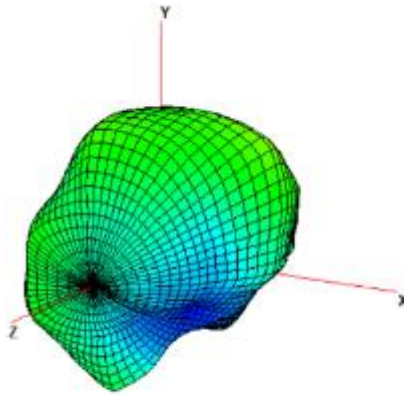

Center Frequency	3800MHz
Horizontal (dBi) peak	-2.68
Vertical (dBi) peak	-3.31

4200MHz

Total

Azimuth = 0.0
Elevation = -15.0
Roll = -30.0

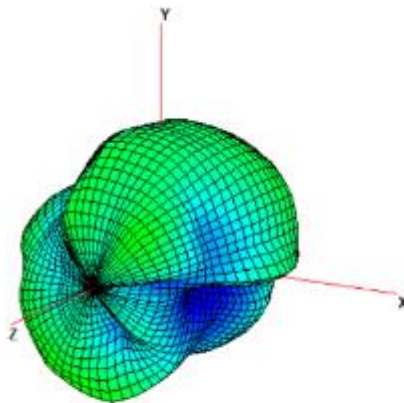

Center Frequency	4200MHz
Horizontal (dBi) peak	-2.58
Vertical (dBi) peak	-1.90

4400MHz

Total

Azimuth = 0.0
Elevation = -15.0
Roll = -30.0

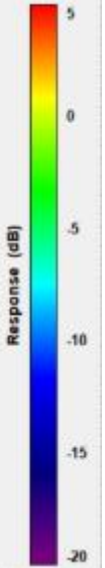
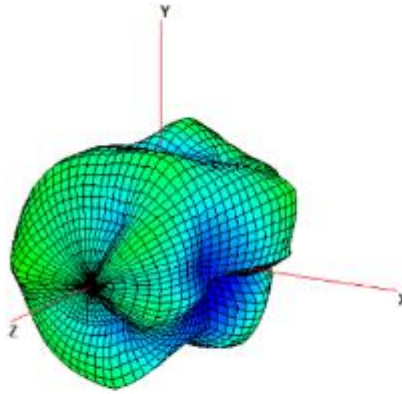

Center Frequency	4400MHz
Horizontal (dBi) peak	-0.89
Vertical (dBi) peak	-3.11

4700MHz

Total

Azimuth = 0.0
Elevation = -15.0
Roll = -30.0

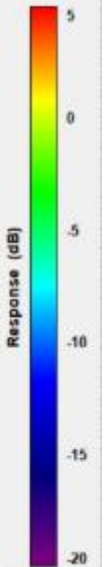
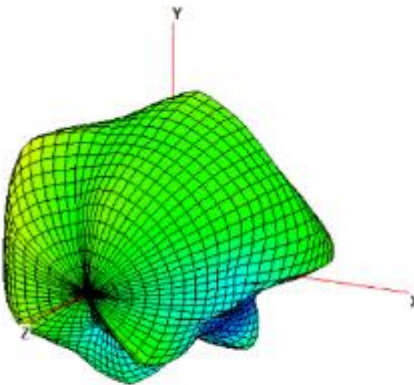

Center Frequency	4700MHz
Horizontal (dBi) peak	-0.90
Vertical (dBi) peak	-2.65

5150MHz

Total

Azimuth = 0.0
Elevation = -15.0
Roll = -30.0

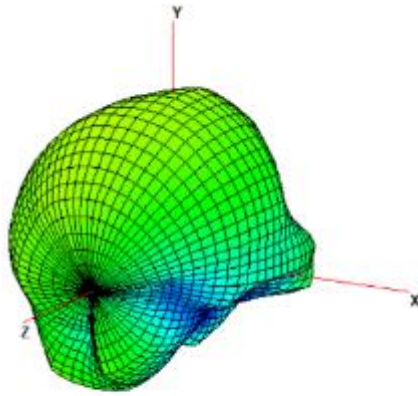

Center Frequency	5150MHz
Horizontal (dBi) peak	0.69
Vertical (dBi) peak	-3.63

5537.5MHz

Total

Azimuth = 0.0
Elevation = -15.0
Roll = -30.0

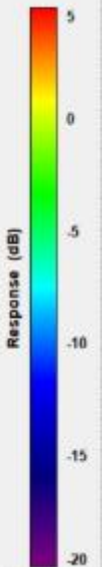
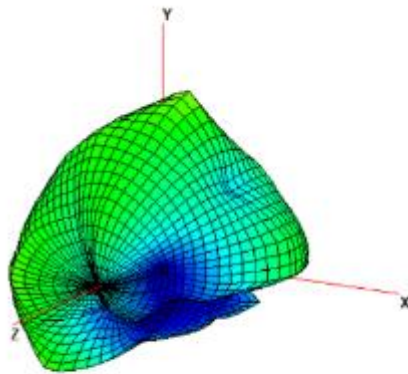

Center Frequency	5537.5MHz
Horizontal (dBi) peak	-3.20
Vertical (dBi) peak	-0.91

5925MHz

Total

Azimuth = 0.0
Elevation = -15.0
Roll = -30.0

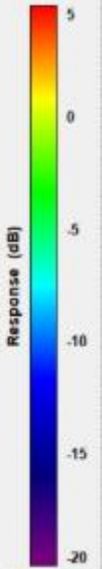
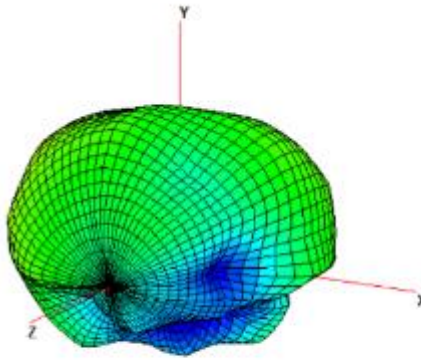

Center Frequency	5925MHz
Horizontal (dBi) peak	-1.08
Vertical (dBi) peak	-0.12

WWAN Aux Antenna (DRx)

717MHz

Total

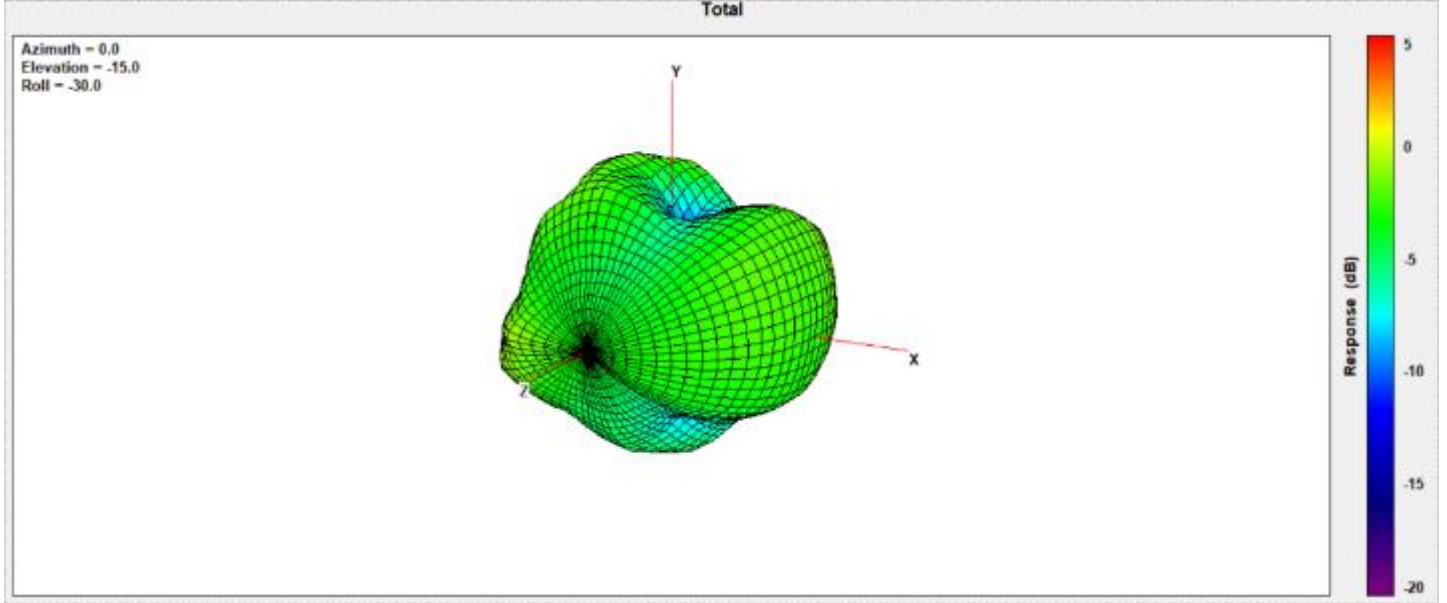

Center Frequency	717MHz
Horizontal (dBi) peak	-1.24
Vertical (dBi) peak	-0.82

725.5MHz

Total

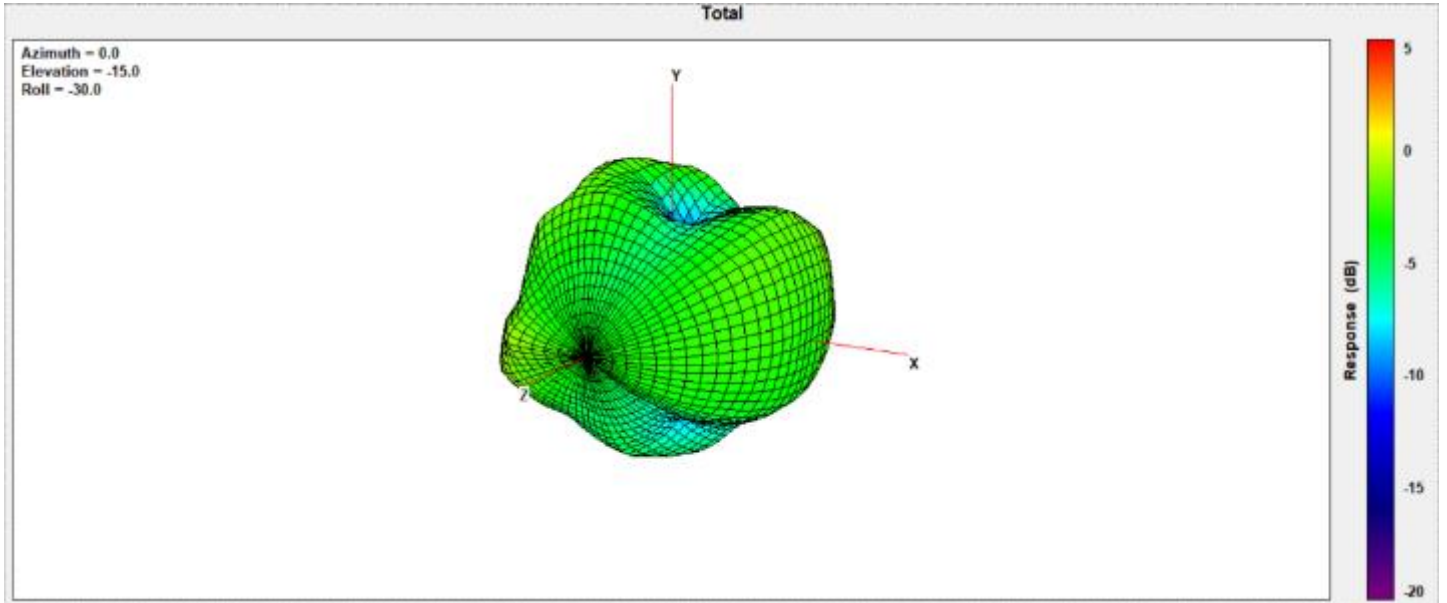

Center Frequency	725.5MHz
Horizontal (dBi) peak	-1.09
Vertical (dBi) peak	-0.85

748MHz

Total

Azimuth = 0.0
Elevation = -15.0
Roll = -30.0

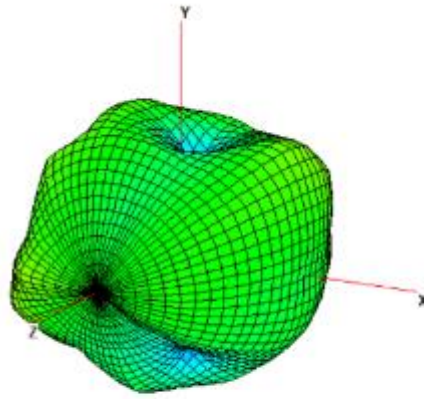

Center Frequency	748MHz
Horizontal (dBi) peak	-0.88
Vertical (dBi) peak	-0.74

756MHz

Total

Azimuth = 0.0
Elevation = -15.0
Roll = -30.0

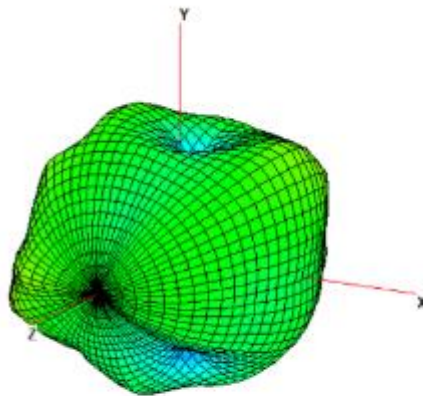

Center Frequency	756MHz
Horizontal (dBi) peak	-0.99
Vertical (dBi) peak	-0.53

768MHz

Total

Azimuth = 0.0
Elevation = -15.0
Roll = -30.0

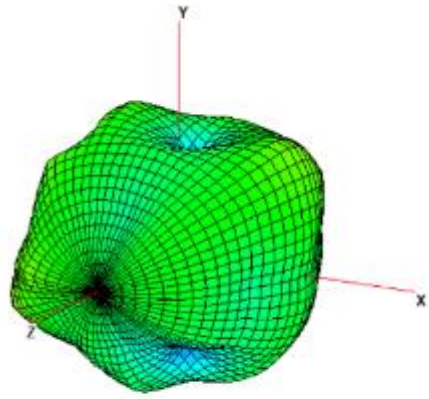

Center Frequency	768MHz
Horizontal (dBi) peak	-1.35
Vertical (dBi) peak	-0.87

777MHz

Total

Azimuth = 0.0
Elevation = -15.0
Roll = -30.0

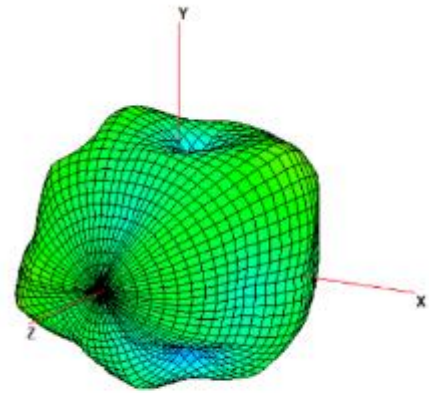

Center Frequency	777MHz
Horizontal (dBi) peak	-2.34
Vertical (dBi) peak	-1.41

782MHz

Total

Azimuth = 0.0
Elevation = -15.0
Roll = -30.0

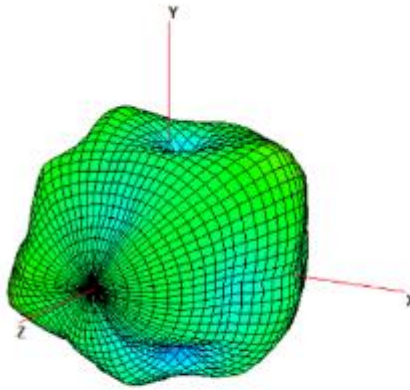

Center Frequency	782MHz
Horizontal (dBi) peak	-2.67
Vertical (dBi) peak	-1.69

787MHz

Total

Azimuth = 0.0
Elevation = -15.0
Roll = -30.0

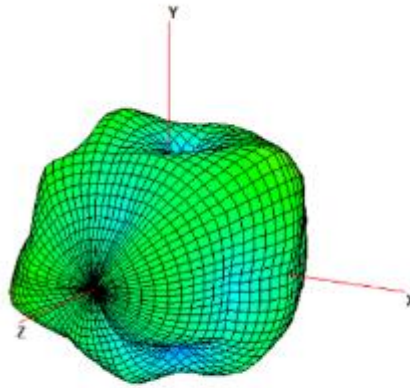

Center Frequency	787MHz
Horizontal (dBi) peak	-2.88
Vertical (dBi) peak	-1.83

814MHz

Total

Azimuth = 0.0
Elevation = -15.0
Roll = -30.0

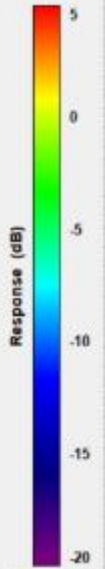
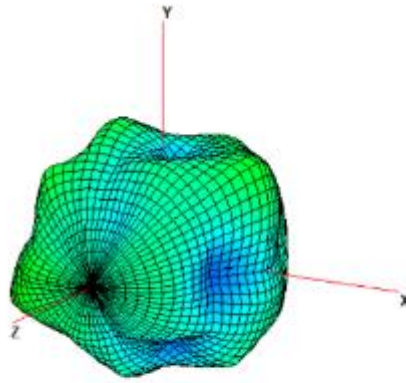

Center Frequency	814MHz
Horizontal (dBi) peak	-3.13
Vertical (dBi) peak	-3.41

824MHz

Total

Azimuth = 0.0
Elevation = -15.0
Roll = -30.0

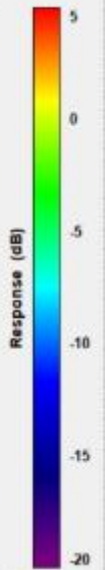
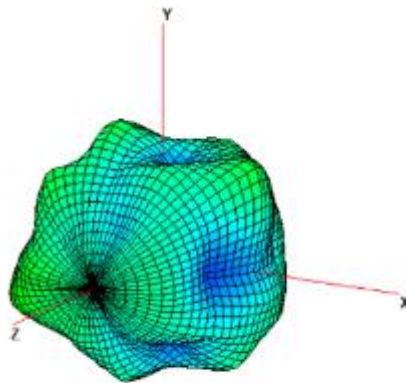

Center Frequency	824MHz
Horizontal (dBi) peak	-3.39
Vertical (dBi) peak	-3.22

832MHz

Total

Azimuth = 0.0
Elevation = -15.0
Roll = -30.0

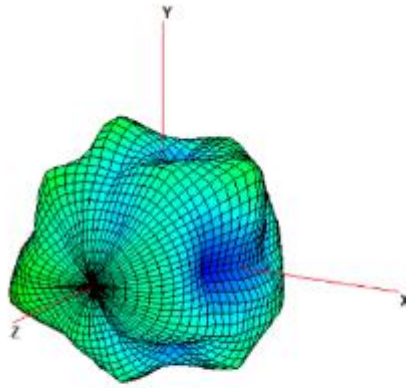

Center Frequency	832MHz
Horizontal (dBi) peak	-3.56
Vertical (dBi) peak	-3.14

836.5MHz

Total

Azimuth = 0.0
Elevation = -15.0
Roll = -30.0

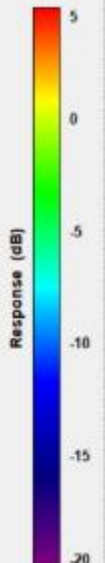
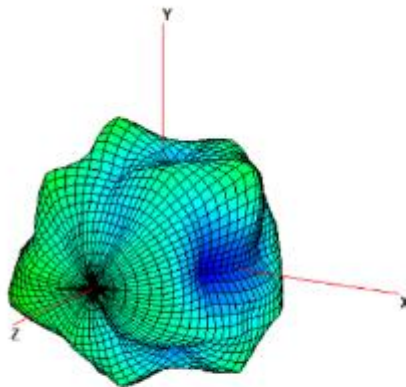

Center Frequency	836.5MHz
Horizontal (dBi) peak	-3.65
Vertical (dBi) peak	-2.84

849MHz

Total

Azimuth = 0.0
Elevation = -15.0
Roll = -30.0

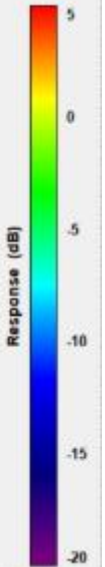
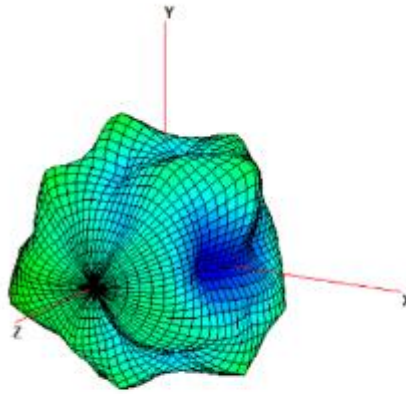

Center Frequency	849MHz
Horizontal (dBi) peak	-3.71
Vertical (dBi) peak	-2.20

862MHz

Total

Azimuth = 0.0
Elevation = -15.0
Roll = -30.0

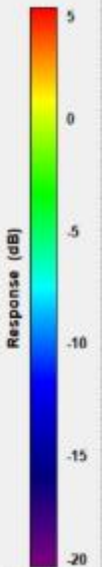
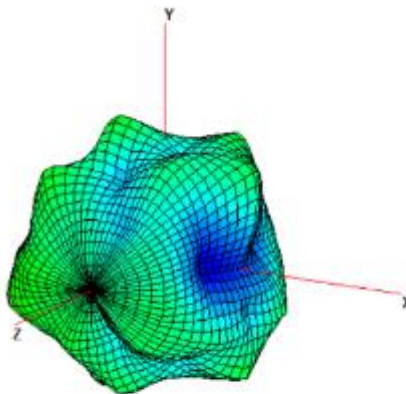

Center Frequency	862MHz
Horizontal (dBi) peak	-3.41
Vertical (dBi) peak	-1.87

880MHz

Total

Azimuth = 0.0
Elevation = -15.0
Roll = -30.0

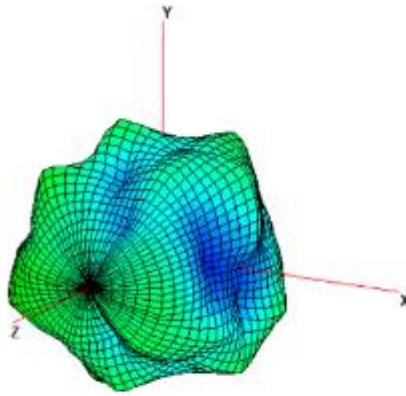

Center Frequency	880MHz
Horizontal (dBi) peak	-3.43
Vertical (dBi) peak	-2.20

897.5MHz

Total

Azimuth = 0.0
Elevation = -15.0
Roll = -30.0

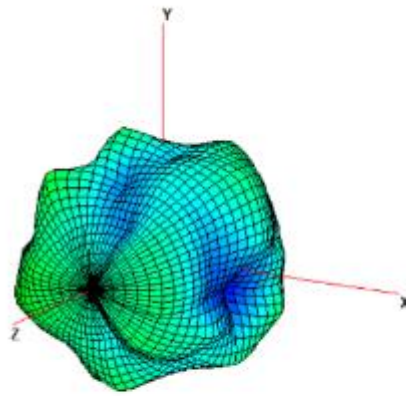

Center Frequency	897.5MHz
Horizontal (dBi) peak	-3.54
Vertical (dBi) peak	-2.60

915MHz

Total

Azimuth = 0.0
Elevation = -15.0
Roll = -30.0

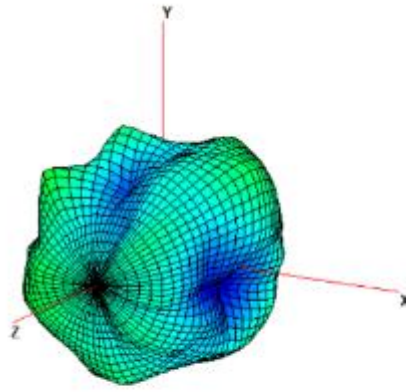

Center Frequency	915MHz
Horizontal (dBi) peak	-3.95
Vertical (dBi) peak	-3.11

925MHz

Total

Azimuth = 0.0
Elevation = -15.0
Roll = -30.0

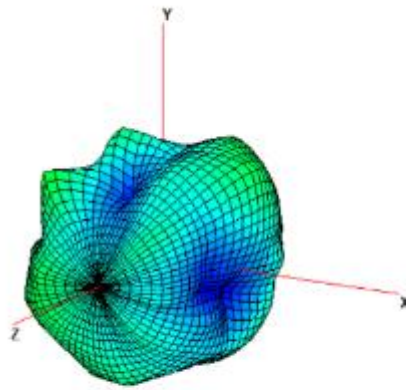

Center Frequency	925MHz
Horizontal (dBi) peak	-4.27
Vertical (dBi) peak	-3.23

960MHz

Total

Azimuth = 0.0
Elevation = -15.0
Roll = -30.0

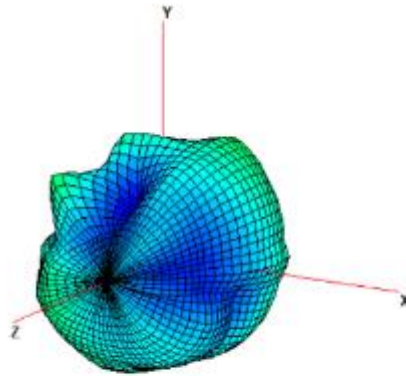

Center Frequency	960MHz
Horizontal (dBi) peak	-6.77
Vertical (dBi) peak	-4.21

1427.9MHz

Total

Azimuth = 0.0
Elevation = -15.0
Roll = -30.0

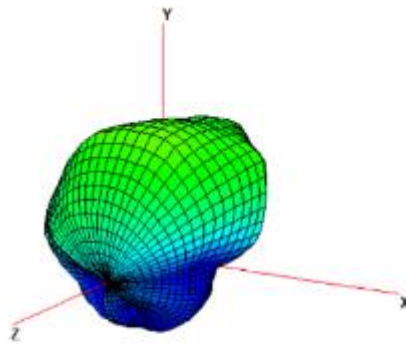

Center Frequency	1427.9MHz
Horizontal (dBi) peak	-4.86
Vertical (dBi) peak	-3.17

1447.9MHz

Total

Azimuth = 0.0
Elevation = -15.0
Roll = -30.0

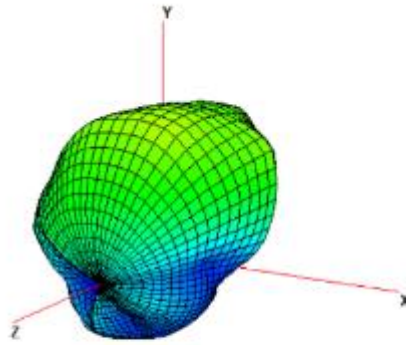

Center Frequency	1447.9MHz
Horizontal (dBi) peak	-4.17
Vertical (dBi) peak	-1.75

1455.4MHz

Total

Azimuth = 0.0
Elevation = -15.0
Roll = -30.0

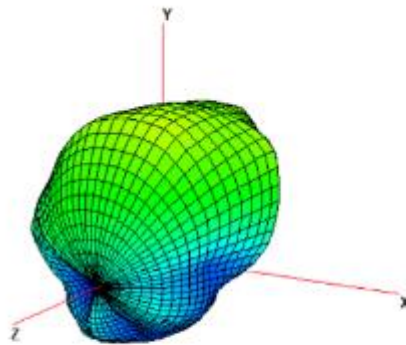

Center Frequency	1455.4MHz
Horizontal (dBi) peak	-4.01
Vertical (dBi) peak	-1.47

1462.9MHz

Total

Azimuth = 0.0
Elevation = -15.0
Roll = -30.0

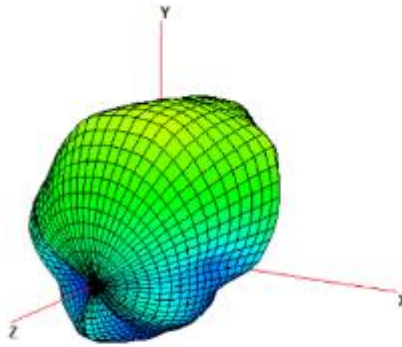

Center Frequency	1462.9MHz
Horizontal (dBi) peak	-3.56
Vertical (dBi) peak	-1.23

1496MHz

Total

Azimuth = 0.0
Elevation = -15.0
Roll = -30.0

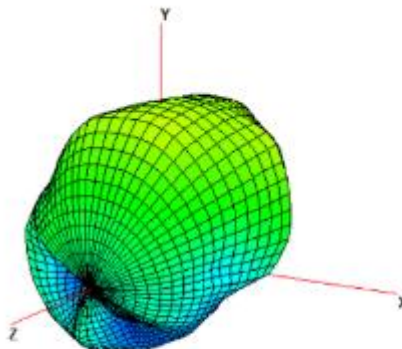

Center Frequency	1496MHz
Horizontal (dBi) peak	-4.15
Vertical (dBi) peak	-0.82

1510.9MHz

Total

Azimuth = 0.0
Elevation = -15.0
Roll = -30.0

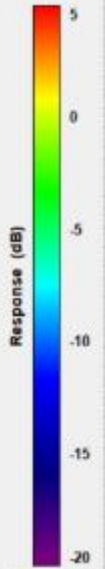
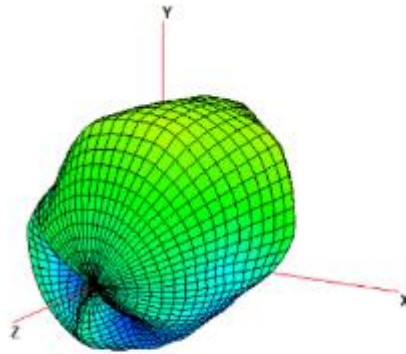

Center Frequency	1510.9MHz
Horizontal (dBi) peak	-4.91
Vertical (dBi) peak	-0.98

1557MHz

Total

Azimuth = 0.0
Elevation = -15.0
Roll = -30.0

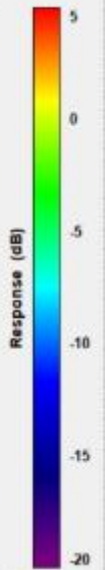
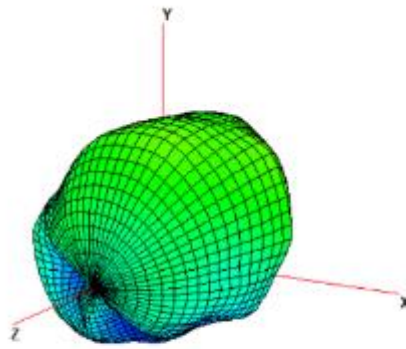

Center Frequency	1557MHz
Horizontal (dBi) peak	-5.17
Vertical (dBi) peak	-2.23

1575MHz

Total

Azimuth = 0.0
Elevation = -15.0
Roll = -30.0

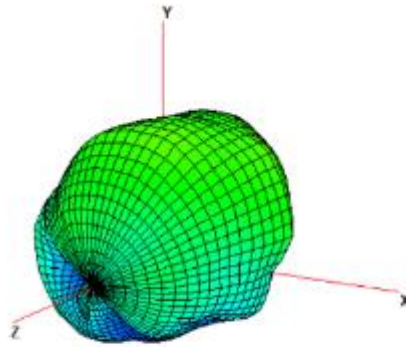

Center Frequency	1575MHz
Horizontal (dBi) peak	-4.80
Vertical (dBi) peak	-2.63

1610MHz

Total

Azimuth = 0.0
Elevation = -15.0
Roll = -30.0

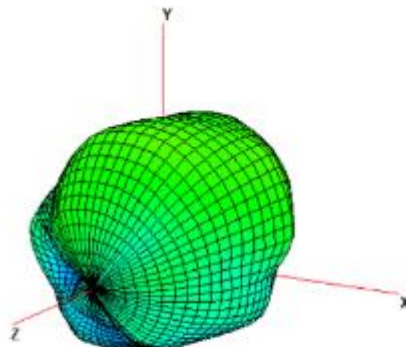

Center Frequency	1610MHz
Horizontal (dBi) peak	-4.12
Vertical (dBi) peak	-2.67

1805 MHz

Total

Azimuth = 0.0
Elevation = -15.0
Roll = -30.0

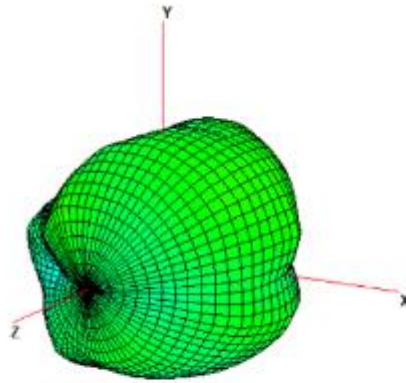

Center Frequency	1805 MHz
Horizontal (dBi) peak	-4.81
Vertical (dBi) peak	-3.52

1850 MHz

Total

Azimuth = 0.0
Elevation = -15.0
Roll = -30.0

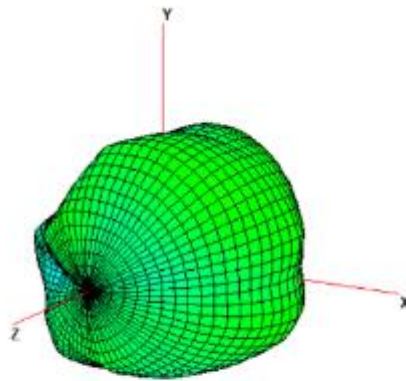

Center Frequency	1850 MHz
Horizontal (dBi) peak	-5.41
Vertical (dBi) peak	-3.73

1880 MHz

Total

Azimuth = 0.0
Elevation = -15.0
Roll = -30.0

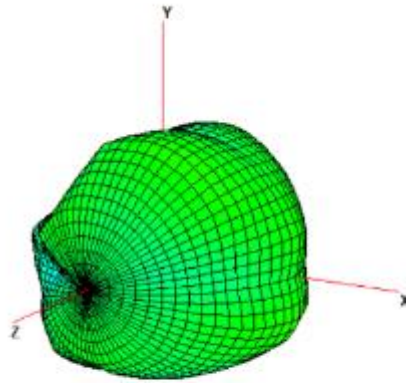

Center Frequency	1880 MHz
Horizontal (dBi) peak	-4.93
Vertical (dBi) peak	-3.53

1910MHz

Total

Azimuth = 0.0
Elevation = -15.0
Roll = -30.0

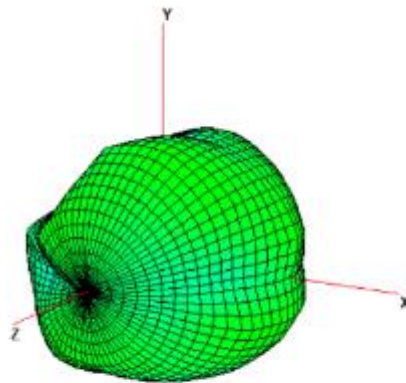

Center Frequency	1910MHz
Horizontal (dBi) peak	-3.83
Vertical (dBi) peak	-3.77

1920MHz

Total

Azimuth = 0.0
Elevation = -15.0
Roll = -30.0

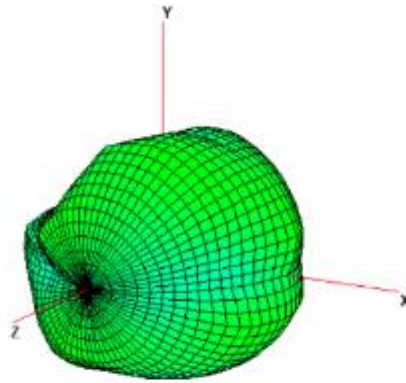

Center Frequency	1920MHz
Horizontal (dBi) peak	-3.90
Vertical (dBi) peak	-3.45

1950MHz

Total

Azimuth = 0.0
Elevation = -15.0
Roll = -30.0

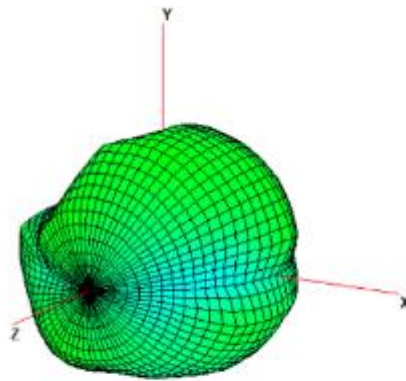

Center Frequency	1950MHz
Horizontal (dBi) peak	-4.25
Vertical (dBi) peak	-2.83

1980MHz

Total

Azimuth = 0.0
Elevation = -15.0
Roll = -30.0

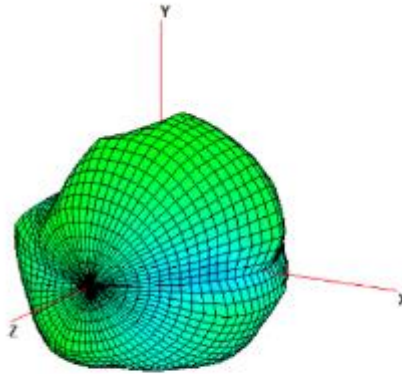

Center Frequency	1980MHz
Horizontal (dBi) peak	-4.33
Vertical (dBi) peak	-2.82

2110MHz

Total

Azimuth = 0.0
Elevation = -15.0
Roll = -30.0

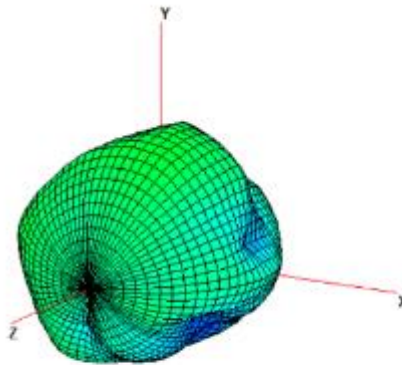

Center Frequency	2110MHz
Horizontal (dBi) peak	-4.56
Vertical (dBi) peak	-3.36

2200MHz

Total

Azimuth = 0.0
Elevation = -15.0
Roll = -30.0

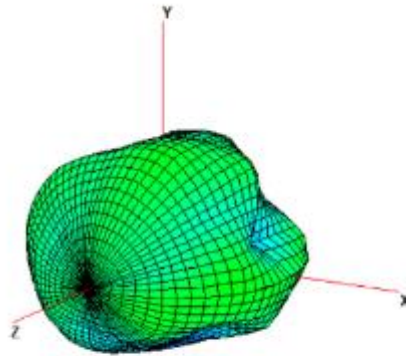

Center Frequency	2200MHz
Horizontal (dBi) peak	-5.14
Vertical (dBi) peak	-4.50

2300MHz

Total

Azimuth = 0.0
Elevation = -15.0
Roll = -30.0

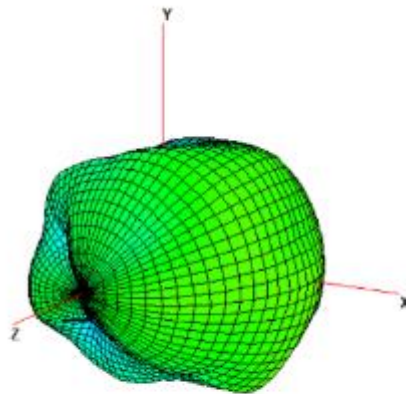

Center Frequency	2300MHz
Horizontal (dBi) peak	-5.25
Vertical (dBi) peak	-2.41

2305MHz

Total

Azimuth = 0.0
Elevation = -15.0
Roll = -30.0

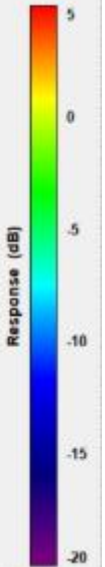
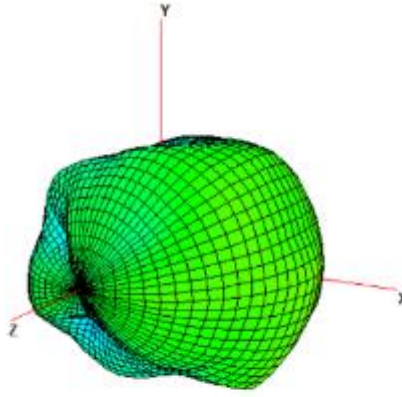

Center Frequency	2305MHz
Horizontal (dBi) peak	-5.29
Vertical (dBi) peak	-2.23

2315MHz

Total

Azimuth = 0.0
Elevation = -15.0
Roll = -30.0

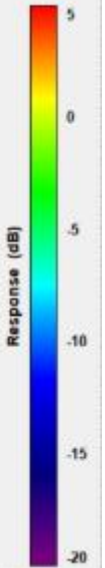
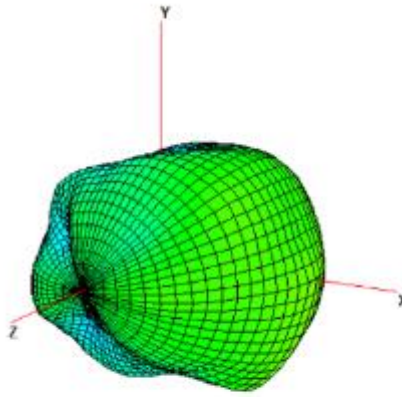

Center Frequency	2315MHz
Horizontal (dBi) peak	-5.50
Vertical (dBi) peak	-2.01

2350MHz

Total

Azimuth = 0.0
Elevation = -15.0
Roll = -30.0

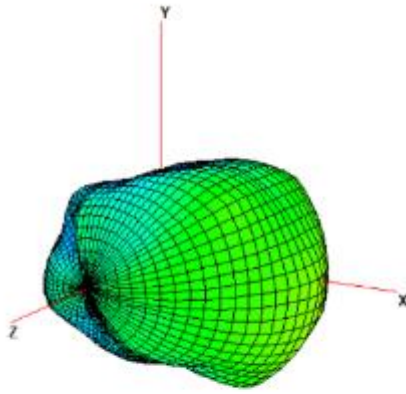

Center Frequency	2350MHz
Horizontal (dBi) peak	-5.95
Vertical (dBi) peak	-1.76

2400MHz

Total

Azimuth = 0.0
Elevation = -15.0
Roll = -30.0

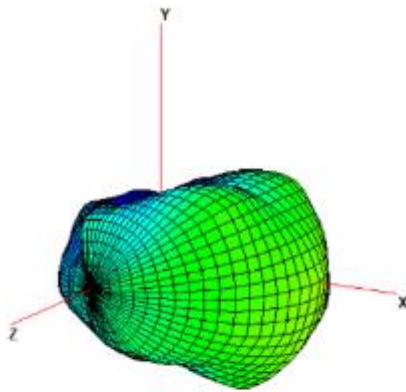

Center Frequency	2400MHz
Horizontal (dBi) peak	-5.91
Vertical (dBi) peak	-2.65

2500MHz

Total

Azimuth = 0.0
Elevation = -15.0
Roll = -30.0

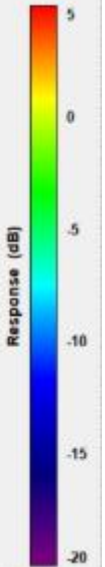
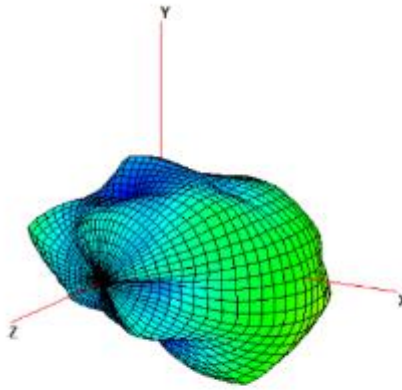

Center Frequency	2500MHz
Horizontal (dBi) peak	-5.18
Vertical (dBi) peak	-4.79

2570MHz

Total

Azimuth = 0.0
Elevation = -15.0
Roll = -30.0

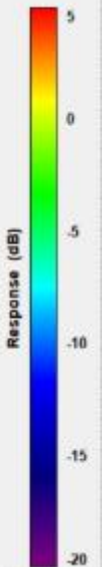
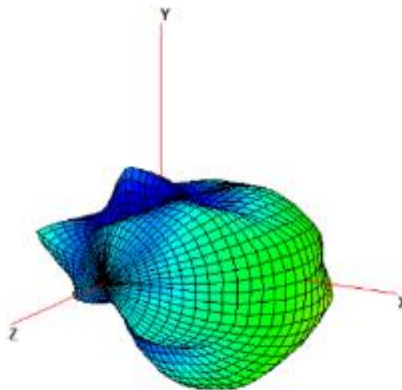

Center Frequency	2570MHz
Horizontal (dBi) peak	-3.68
Vertical (dBi) peak	-2.74

2595MHz

Total

Azimuth = 0.0
Elevation = -15.0
Roll = -30.0

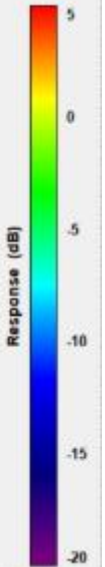
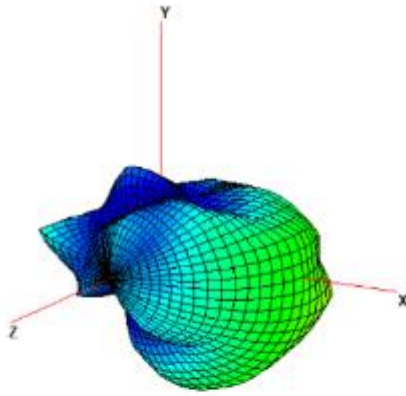

Center Frequency	2595MHz
Horizontal (dBi) peak	-3.55
Vertical (dBi) peak	-1.91

2620MHz

Total

Azimuth = 0.0
Elevation = -15.0
Roll = -30.0

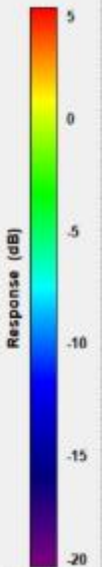
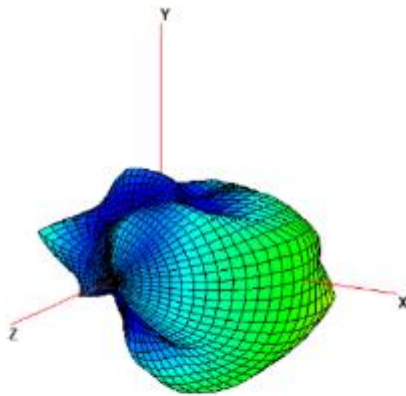

Center Frequency	2620MHz
Horizontal (dBi) peak	-3.32
Vertical (dBi) peak	-1.09

2690MHz

Total

Azimuth = 0.0
Elevation = -15.0
Roll = -30.0

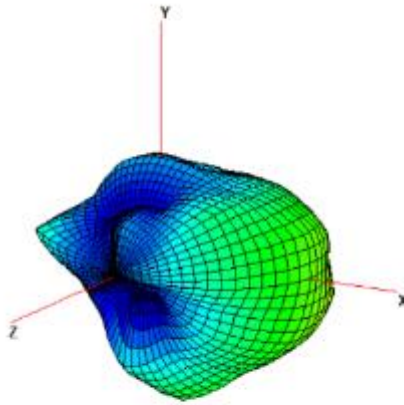

Center Frequency	2690MHz
Horizontal (dBi) peak	-2.30
Vertical (dBi) peak	-1.19

3400MHz

Total

Azimuth = 0.0
Elevation = -15.0
Roll = -30.0

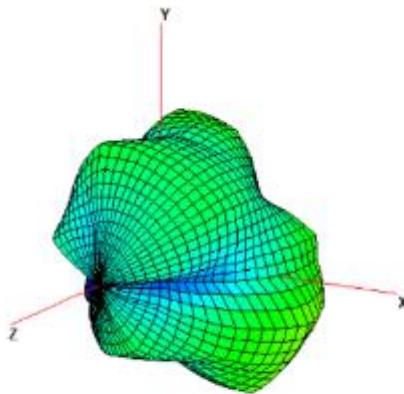

Center Frequency	3400MHz
Horizontal (dBi) peak	-5.31
Vertical (dBi) peak	-3.68

3500MHz

Total

Azimuth = 0.0
Elevation = -15.0
Roll = -30.0

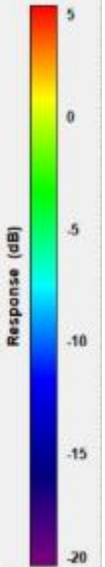
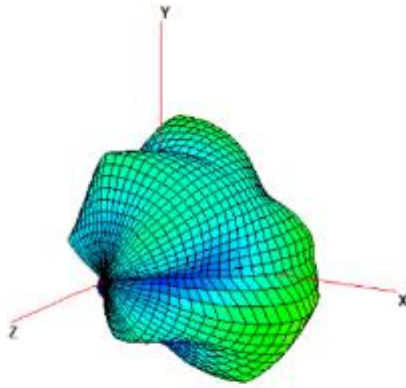

Center Frequency	3500MHz
Horizontal (dBi) peak	-5.33
Vertical (dBi) peak	-3.48

3600MHz

Total

Azimuth = 0.0
Elevation = -15.0
Roll = -30.0

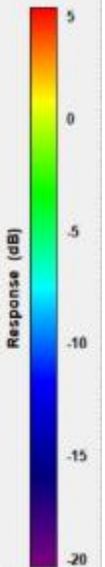
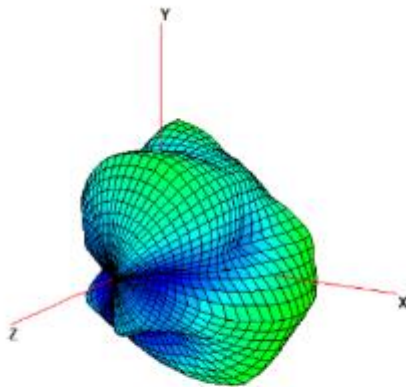

Center Frequency	3600MHz
Horizontal (dBi) peak	-5.23
Vertical (dBi) peak	-5.66

3700MHz

Total

Azimuth = 0.0
Elevation = -15.0
Roll = -30.0

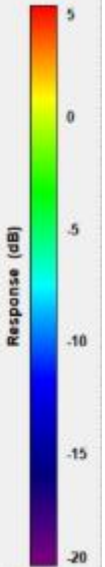
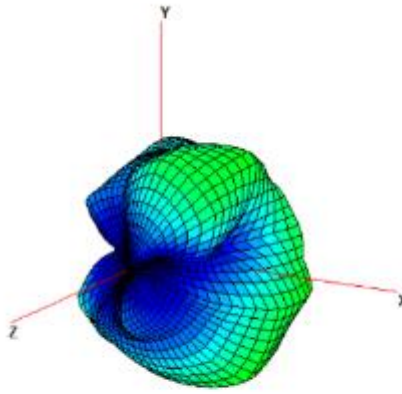

Center Frequency	3700MHz
Horizontal (dBi) peak	-4.06
Vertical (dBi) peak	-3.39

3800MHz

Total

Azimuth = 0.0
Elevation = -15.0
Roll = -30.0

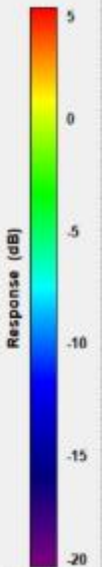
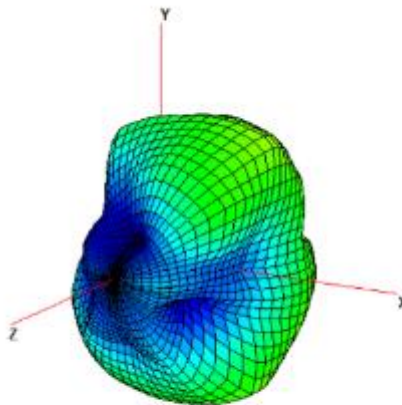

Center Frequency	3800MHz
Horizontal (dBi) peak	-2.01
Vertical (dBi) peak	-1.81

4200MHz

Total

Azimuth = 0.0
Elevation = -15.0
Roll = -30.0

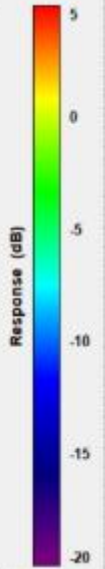
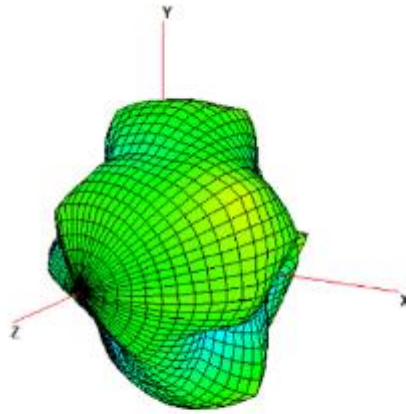

Center Frequency	4200MHz
Horizontal (dBi) peak	-1.79
Vertical (dBi) peak	-3.10

4400MHz

Total

Azimuth = 0.0
Elevation = -15.0
Roll = -30.0

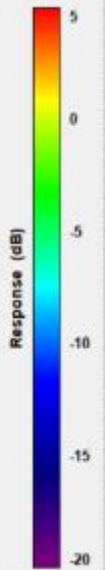
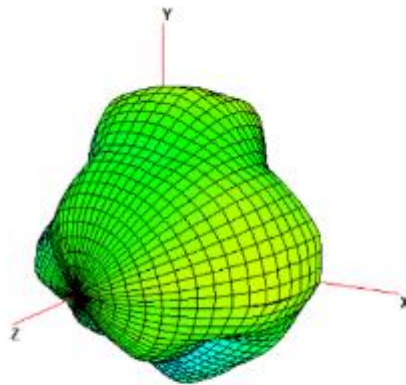

Center Frequency	4400MHz
Horizontal (dBi) peak	-2.06
Vertical (dBi) peak	-3.08

4700MHz

Total

Azimuth = 0.0
Elevation = -15.0
Roll = -30.0

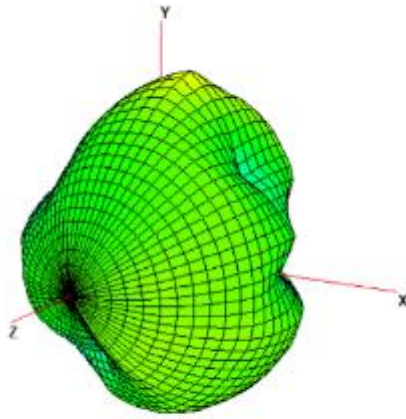

Center Frequency	4700MHz
Horizontal (dBi) peak	-0.96
Vertical (dBi) peak	-3.13

5150MHz

Total

Azimuth = 0.0
Elevation = -15.0
Roll = -30.0

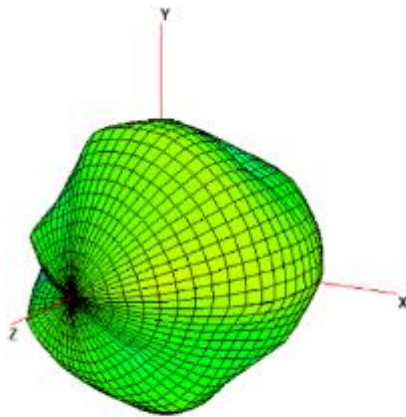

Center Frequency	5150MHz
Horizontal (dBi) peak	-3.41
Vertical (dBi) peak	-3.18

5537.5MHz

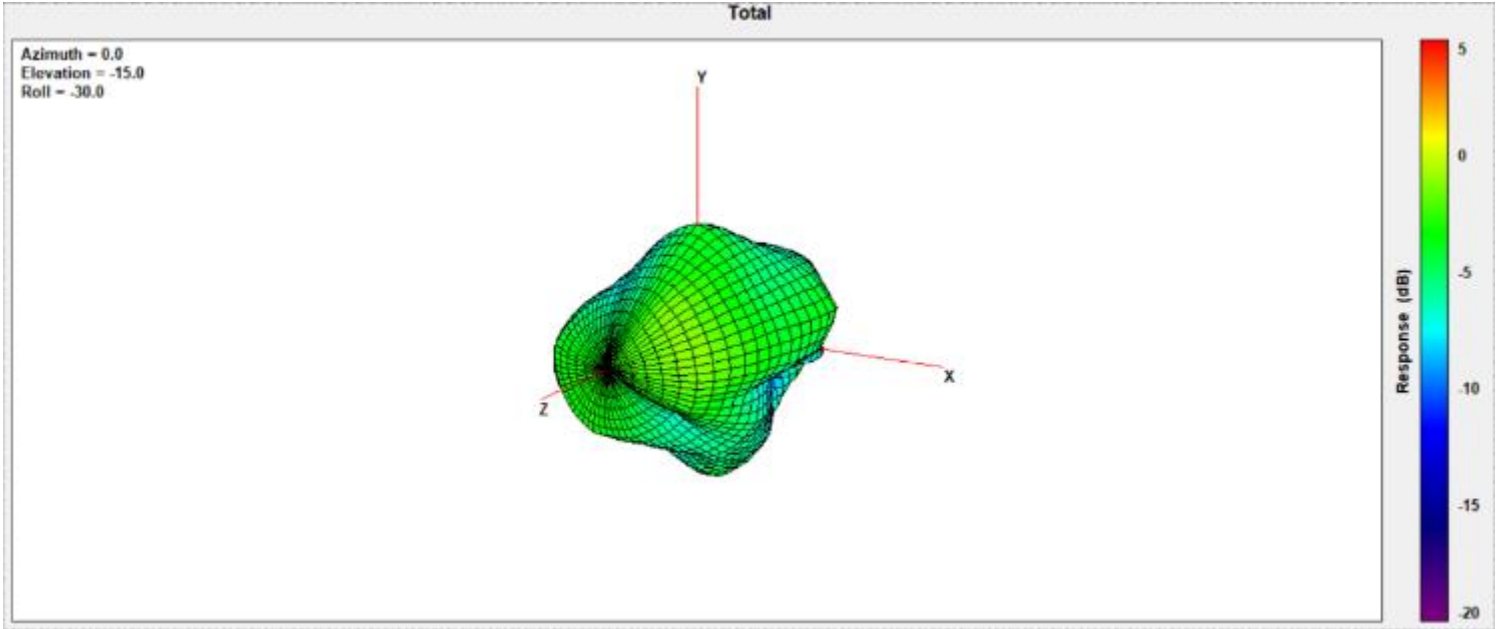

Center Frequency	5537.5MHz
Horizontal (dBi) peak	-2.42
Vertical (dBi) peak	-5.12

5925MHz

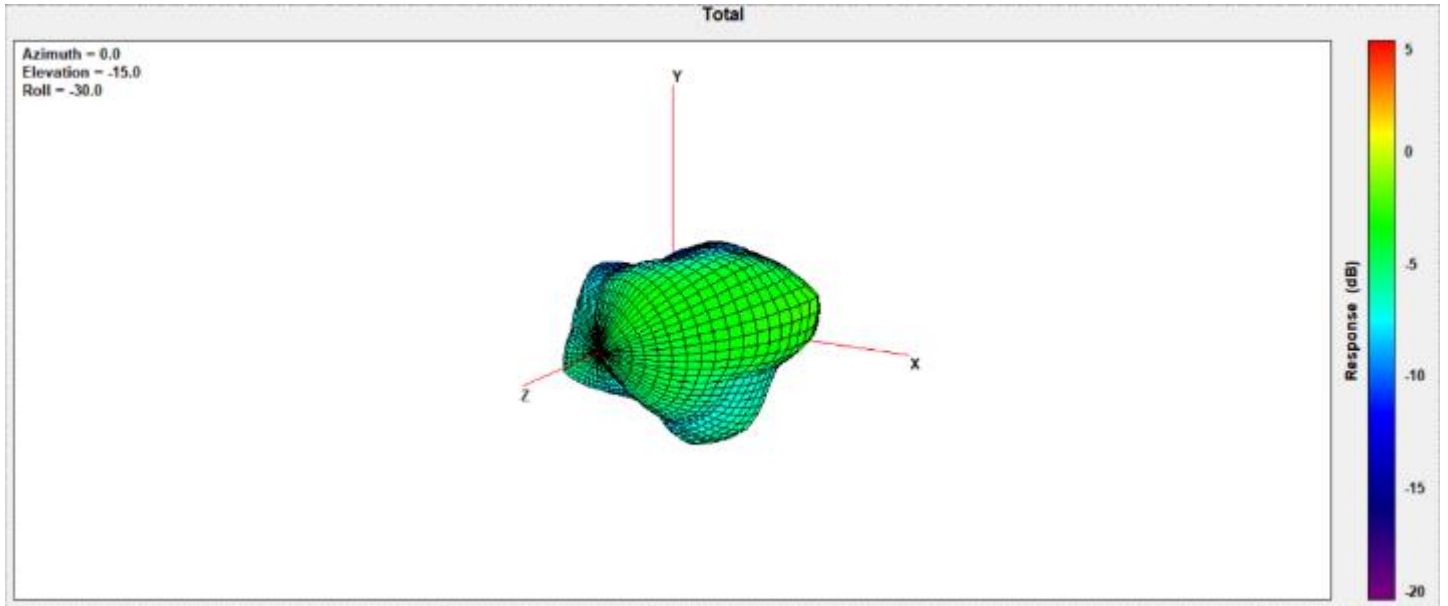

Center Frequency	5925MHz
Horizontal (dBi) peak	-4.26
Vertical (dBi) peak	-7.95

MIMO2 Antenna (DRx2)

1710 MHz

Total

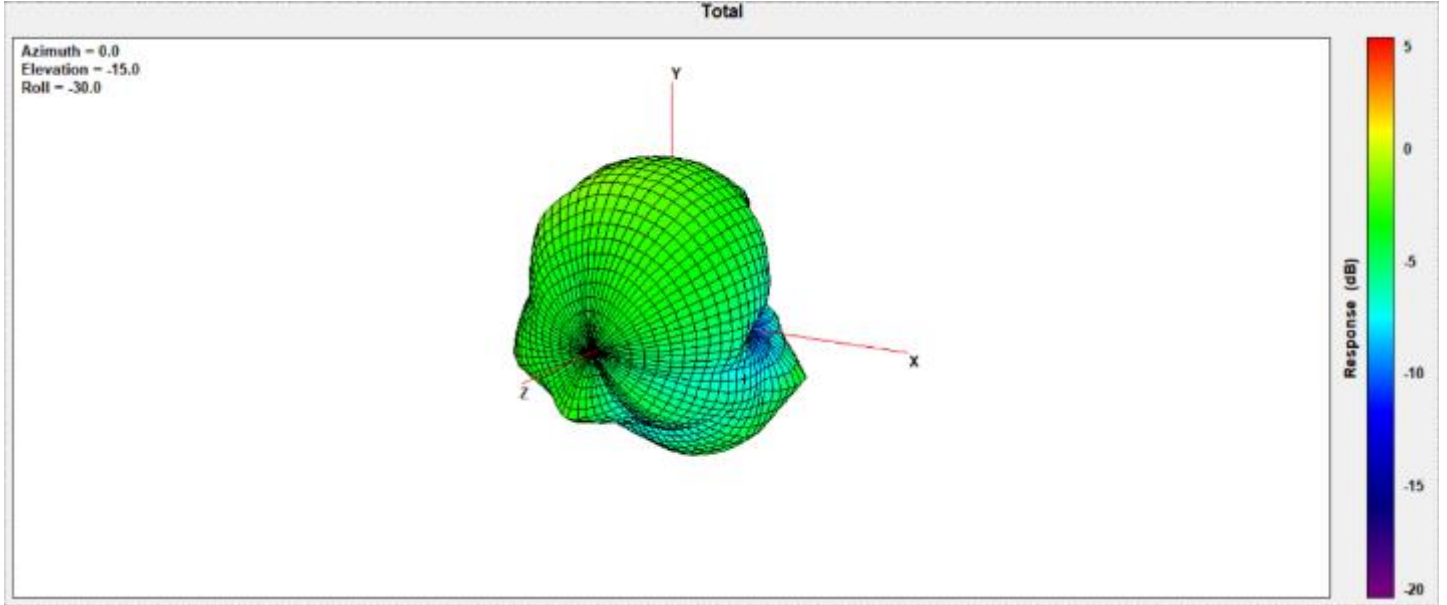

Center Frequency	1710 MHz
Horizontal (dBi) peak	-2.13
Vertical (dBi) peak	-2.73

1732.5 MHz

Total

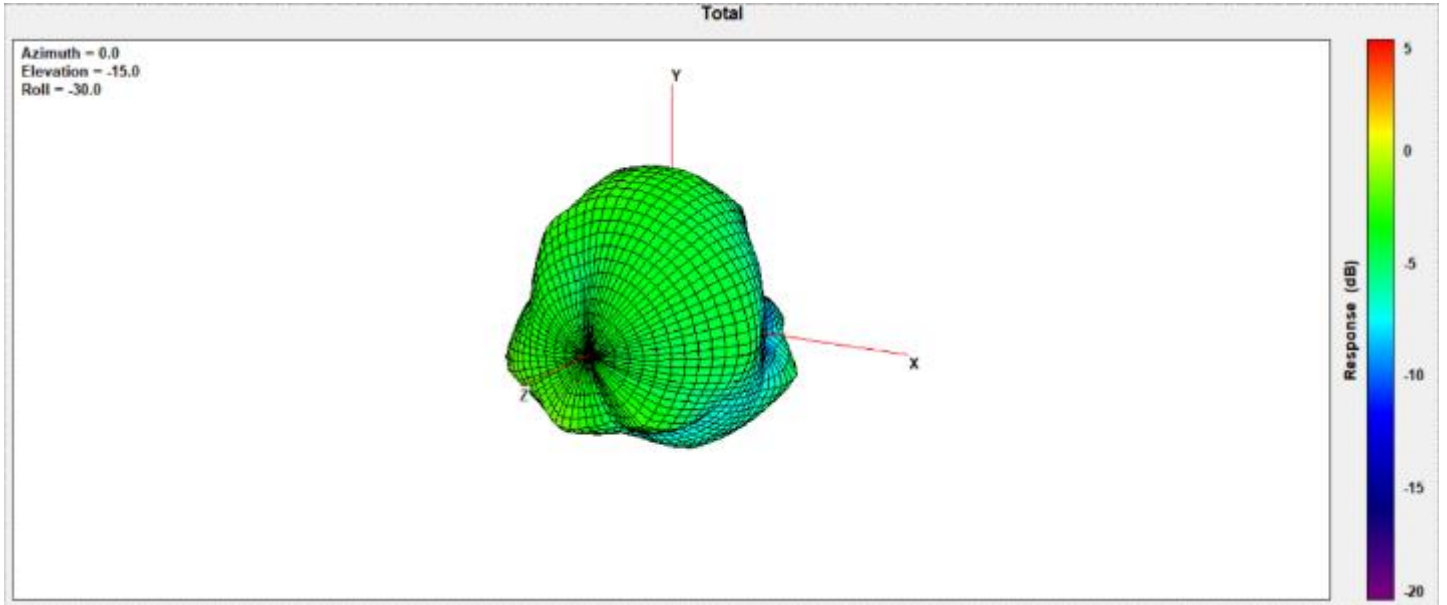

Center Frequency	1732.5 MHz
Horizontal (dBi) peak	-2.66
Vertical (dBi) peak	-2.72

1747.5 MHz

Total

Azimuth = 0.0
Elevation = -15.0
Roll = -30.0

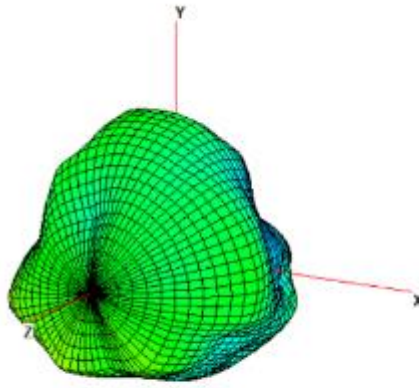

Center Frequency	1747.5 MHz
Horizontal (dBi) peak	-2.29
Vertical (dBi) peak	-1.97

1755 MHz

Total

Azimuth = 0.0
Elevation = -15.0
Roll = -30.0

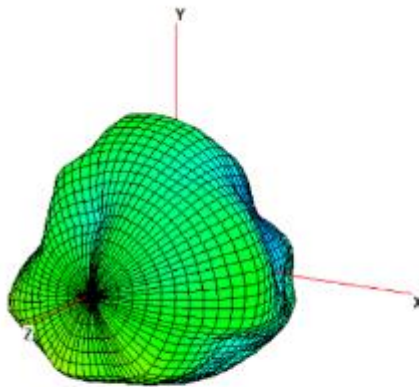

Center Frequency	1755 MHz
Horizontal (dBi) peak	-2.21
Vertical (dBi) peak	-1.75

1785 MHz

Total

Azimuth = 0.0
Elevation = -15.0
Roll = -30.0

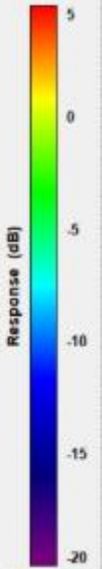
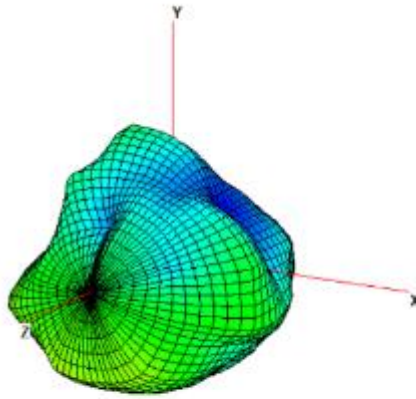

Center Frequency	1785 MHz
Horizontal (dBi) peak	-2.34
Vertical (dBi) peak	-4.25

1805 MHz

Total

Azimuth = 0.0
Elevation = -15.0
Roll = -30.0

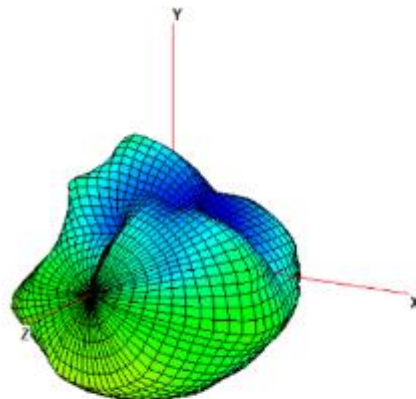

Center Frequency	1805 MHz
Horizontal (dBi) peak	-2.17
Vertical (dBi) peak	-4.78

1850 MHz

Total

Azimuth = 0.0
Elevation = -15.0
Roll = -30.0

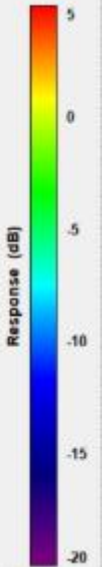
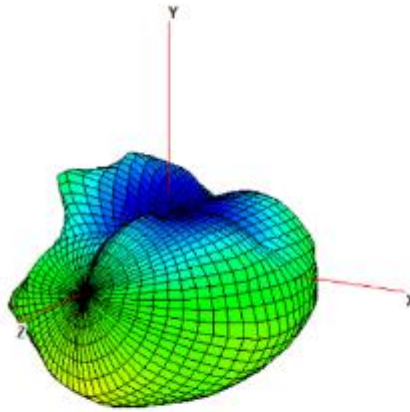

Center Frequency	1850 MHz
Horizontal (dBi) peak	-2.56
Vertical (dBi) peak	-2.53

1880 MHz

Total

Azimuth = 0.0
Elevation = -15.0
Roll = -30.0

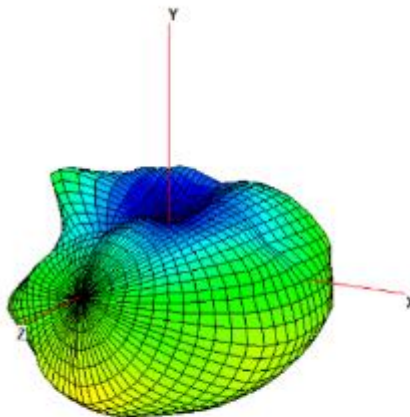

Center Frequency	1880 MHz
Horizontal (dBi) peak	-0.81
Vertical (dBi) peak	-1.18

1910MHz

Total

Azimuth = 0.0
Elevation = -15.0
Roll = -30.0

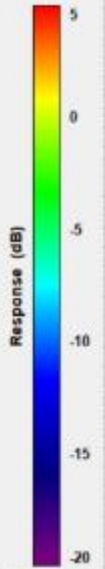
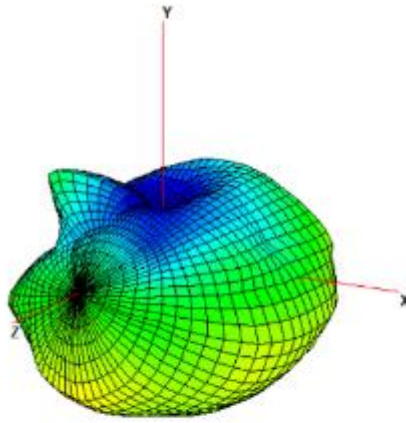

Center Frequency	1910MHz
Horizontal (dBi) peak	-0.45
Vertical (dBi) peak	-0.46

1920MHz

Total

Azimuth = 0.0
Elevation = -15.0
Roll = -30.0

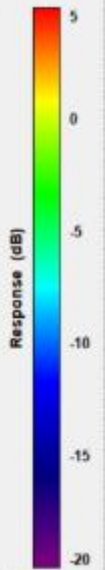
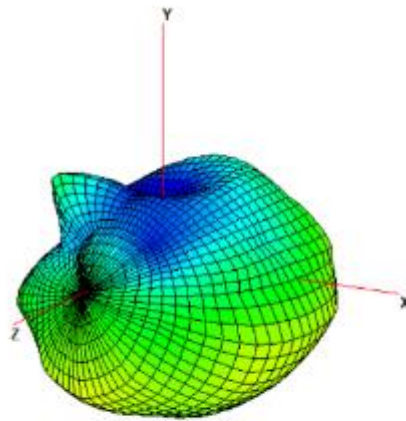

Center Frequency	1920MHz
Horizontal (dBi) peak	-1.02
Vertical (dBi) peak	-0.34

1950MHz

Total

Azimuth = 0.0
Elevation = -15.0
Roll = -30.0

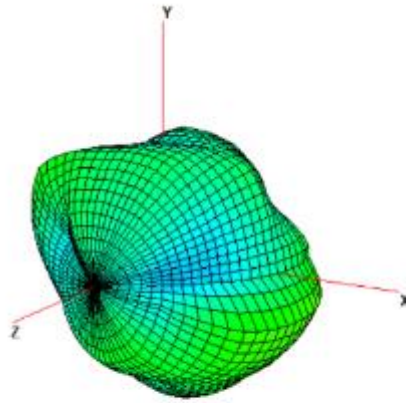

Center Frequency	1950MHz
Horizontal (dBi) peak	-3.18
Vertical (dBi) peak	-2.27

1980MHz

Total

Azimuth = 0.0
Elevation = -15.0
Roll = -30.0

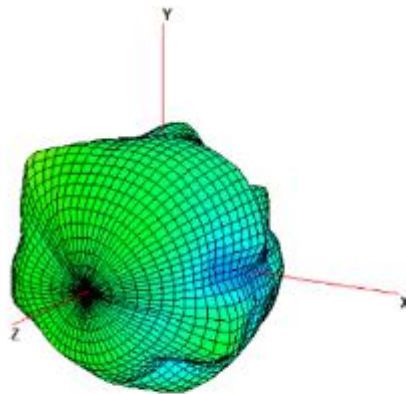

Center Frequency	1980MHz
Horizontal (dBi) peak	-1.40
Vertical (dBi) peak	-3.57

2110MHz

Total

Azimuth = 0.0
Elevation = -15.0
Roll = -30.0

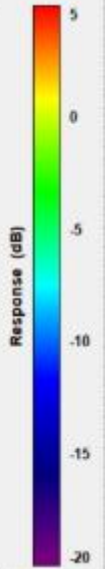
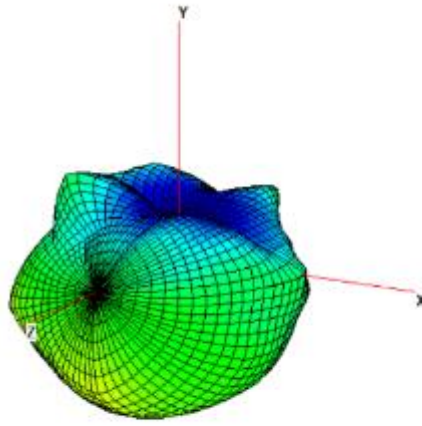

Center Frequency	2110MHz
Horizontal (dBi) peak	-2.55
Vertical (dBi) peak	-2.63

2200MHz

Total

Azimuth = 0.0
Elevation = -15.0
Roll = -30.0

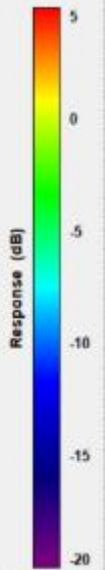
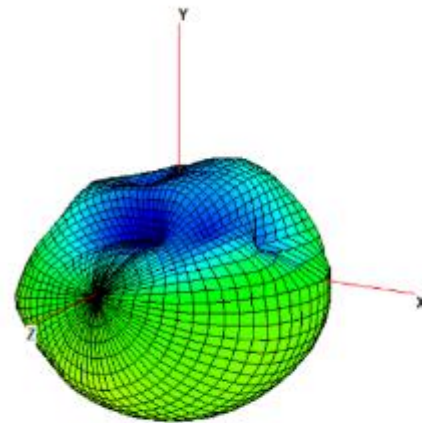

Center Frequency	2200MHz
Horizontal (dBi) peak	-0.91
Vertical (dBi) peak	-1.49

2300MHz

Total

Azimuth = 0.0
Elevation = -15.0
Roll = -30.0

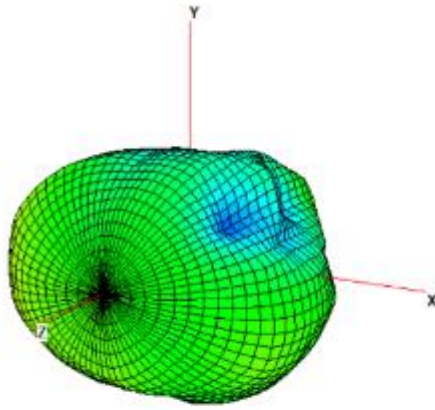

Center Frequency	2300MHz
Horizontal (dBi) peak	0.33
Vertical (dBi) peak	-2.63

2305MHz

Total

Azimuth = 0.0
Elevation = -15.0
Roll = -30.0

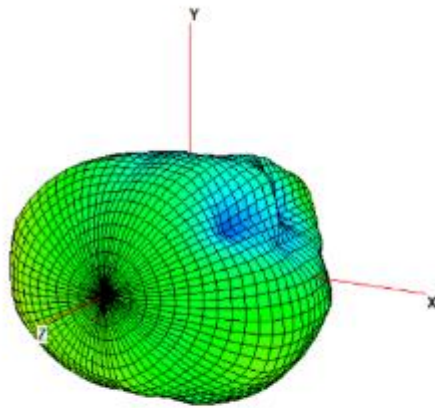

Center Frequency	2305MHz
Horizontal (dBi) peak	0.02
Vertical (dBi) peak	-2.78

2315MHz

Total

Azimuth = 0.0
Elevation = -15.0
Roll = -30.0

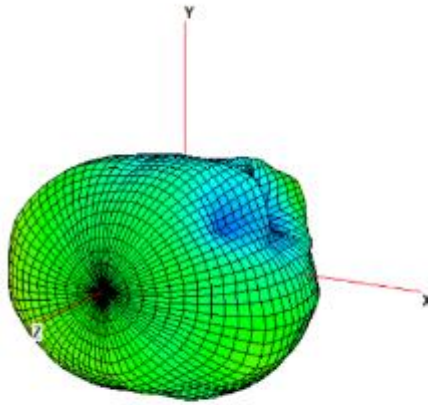

Center Frequency	2315MHz
Horizontal (dBi) peak	-0.77
Vertical (dBi) peak	-3.07

2350MHz

Total

Azimuth = 0.0
Elevation = -15.0
Roll = -30.0

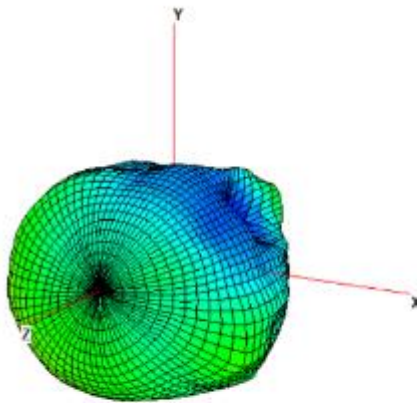

Center Frequency	2350MHz
Horizontal (dBi) peak	-2.09
Vertical (dBi) peak	-3.36

2400MHz

Total

Azimuth = 0.0
Elevation = -15.0
Roll = -30.0

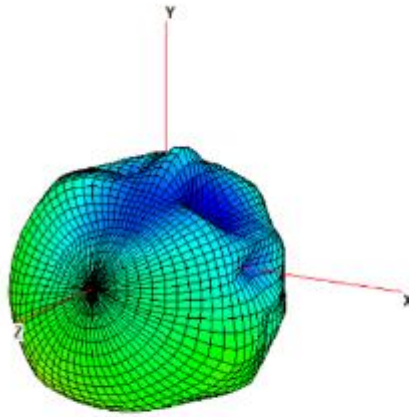

Center Frequency	2400MHz
Horizontal (dBi) peak	-1.96
Vertical (dBi) peak	-2.92

2500MHz

Total

Azimuth = 0.0
Elevation = -15.0
Roll = -30.0

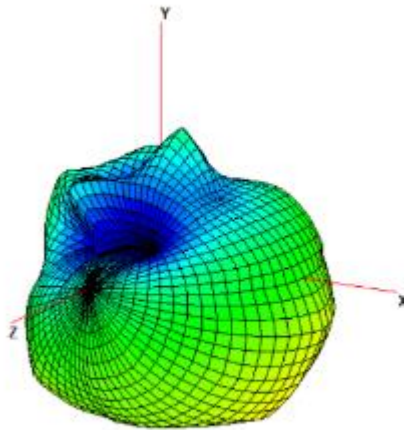

Center Frequency	2500MHz
Horizontal (dBi) peak	-1.82
Vertical (dBi) peak	0.06

2570MHz

Total

Azimuth = 0.0
Elevation = -15.0
Roll = -30.0

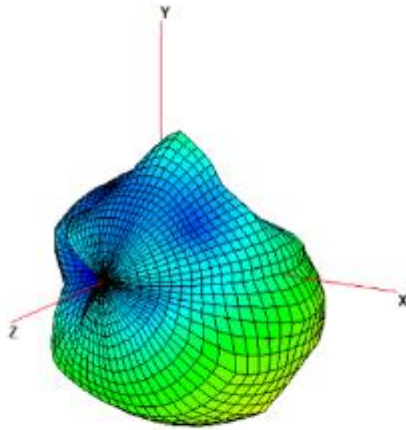

Center Frequency	2570MHz
Horizontal (dBi) peak	-2.96
Vertical (dBi) peak	0.27

2595MHz

Total

Azimuth = 0.0
Elevation = -15.0
Roll = -30.0

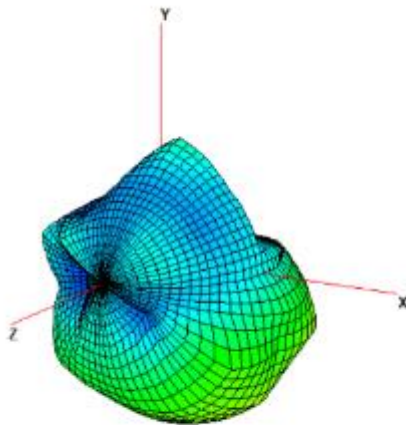

Center Frequency	2595MHz
Horizontal (dBi) peak	-3.67
Vertical (dBi) peak	-0.62

2620MHz

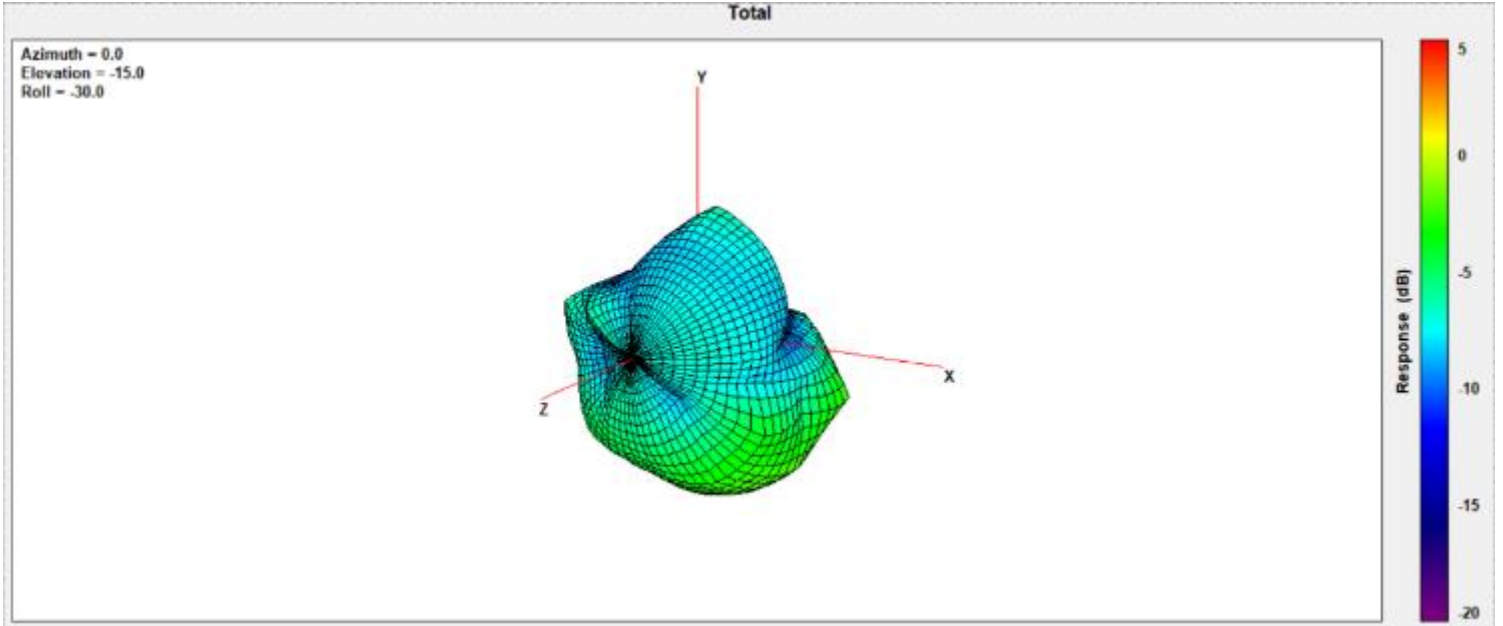

Center Frequency	2620MHz
Horizontal (dBi) peak	-4.33
Vertical (dBi) peak	-1.82

2690MHz

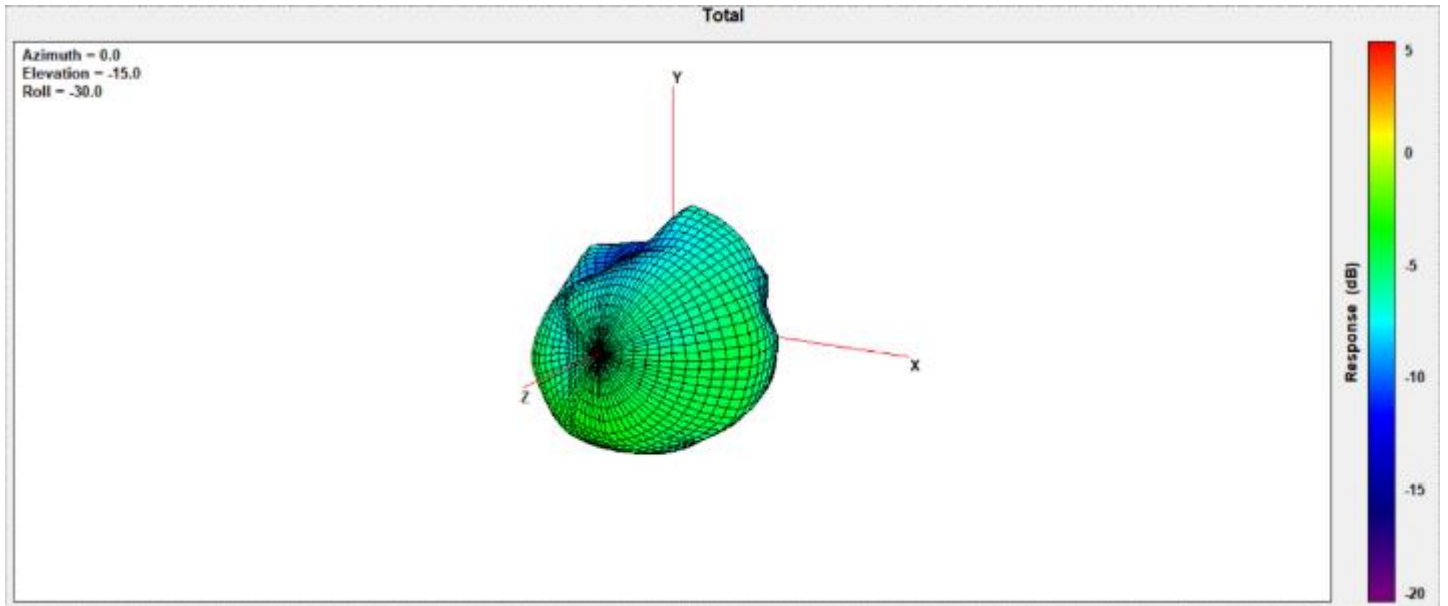

Center Frequency	2690MHz
Horizontal (dBi) peak	-5.59
Vertical (dBi) peak	-4.61

3400MHz

Total

Azimuth = 0.0
Elevation = -15.0
Roll = -30.0

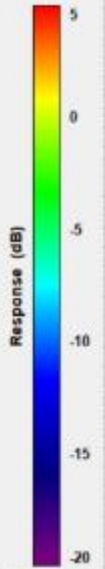
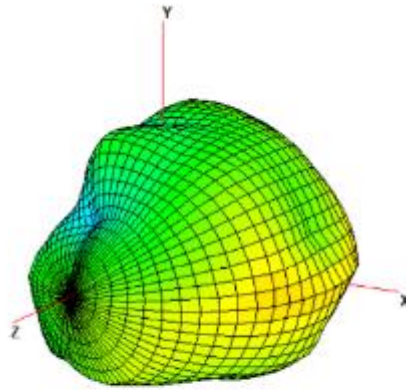

Center Frequency	3400MHz
Horizontal (dBi) peak	-3.28
Vertical (dBi) peak	-0.16

3500MHz

Total

Azimuth = 0.0
Elevation = -15.0
Roll = -30.0

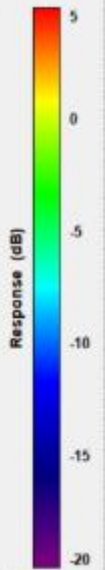
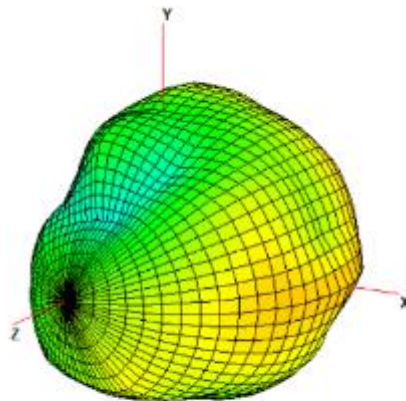

Center Frequency	3500MHz
Horizontal (dBi) peak	-2.75
Vertical (dBi) peak	0.41

3600MHz

Total

Azimuth = 0.0
Elevation = -15.0
Roll = -30.0

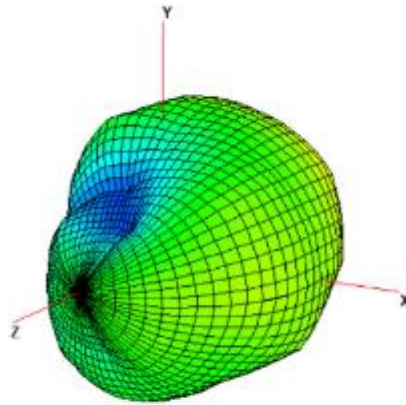

Center Frequency	3600MHz
Horizontal (dBi) peak	-2.59
Vertical (dBi) peak	-1.01

3700MHz

Total

Azimuth = 0.0
Elevation = -15.0
Roll = -30.0

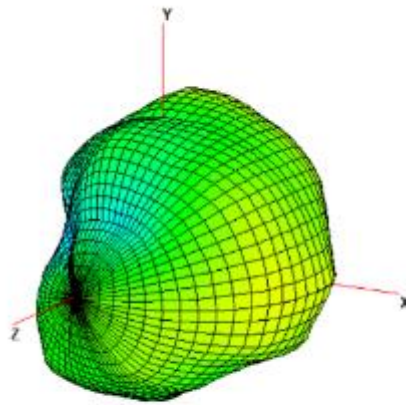

Center Frequency	3700MHz
Horizontal (dBi) peak	-1.87
Vertical (dBi) peak	-1.31

3800MHz

Total

Azimuth = 0.0
Elevation = -15.0
Roll = -30.0

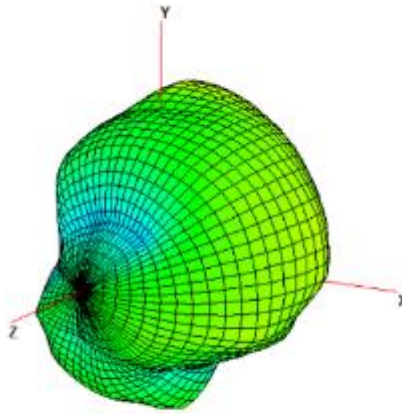

Center Frequency	3800MHz
Horizontal (dBi) peak	-0.49
Vertical (dBi) peak	-1.62

4200MHz

Total

Azimuth = 0.0
Elevation = -15.0
Roll = -30.0

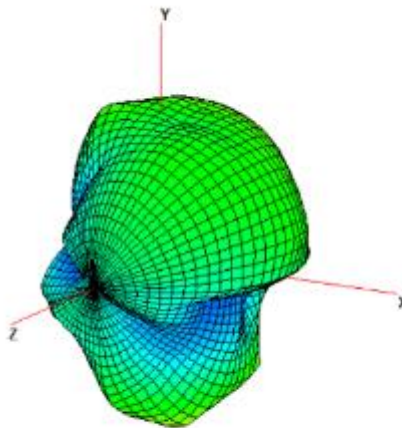

Center Frequency	4200MHz
Horizontal (dBi) peak	-2.75
Vertical (dBi) peak	-4.86

4400MHz

Total

Azimuth = 0.0
Elevation = -15.0
Roll = -30.0

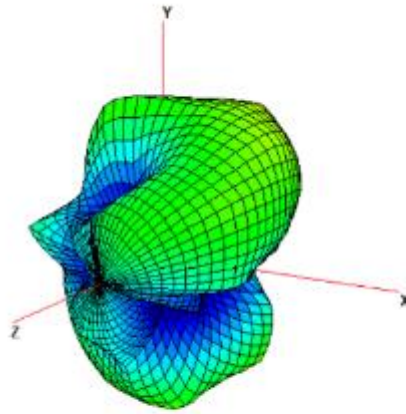

Center Frequency	4400MHz
Horizontal (dBi) peak	-0.68
Vertical (dBi) peak	-2.67

4700MHz

Total

Azimuth = 0.0
Elevation = -15.0
Roll = -30.0

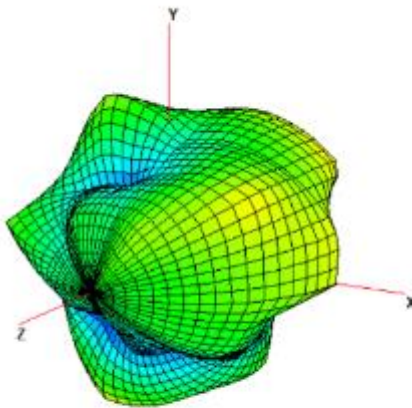

Center Frequency	4700MHz
Horizontal (dBi) peak	-1.40
Vertical (dBi) peak	-2.31

5000MHz

Total

Azimuth = 0.0
Elevation = -15.0
Roll = -30.0

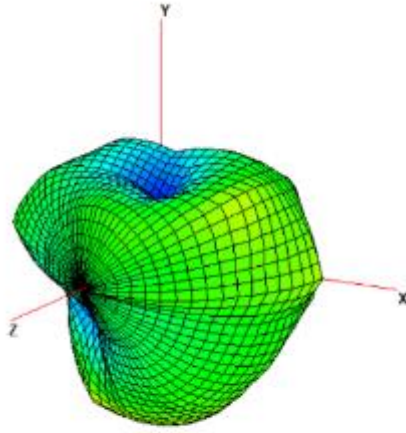

Center Frequency	5000MHz
Horizontal (dBi) peak	-2.61
Vertical (dBi) peak	-2.03

MIMO3 Antenna (DRx1)

1805 MHz

Total

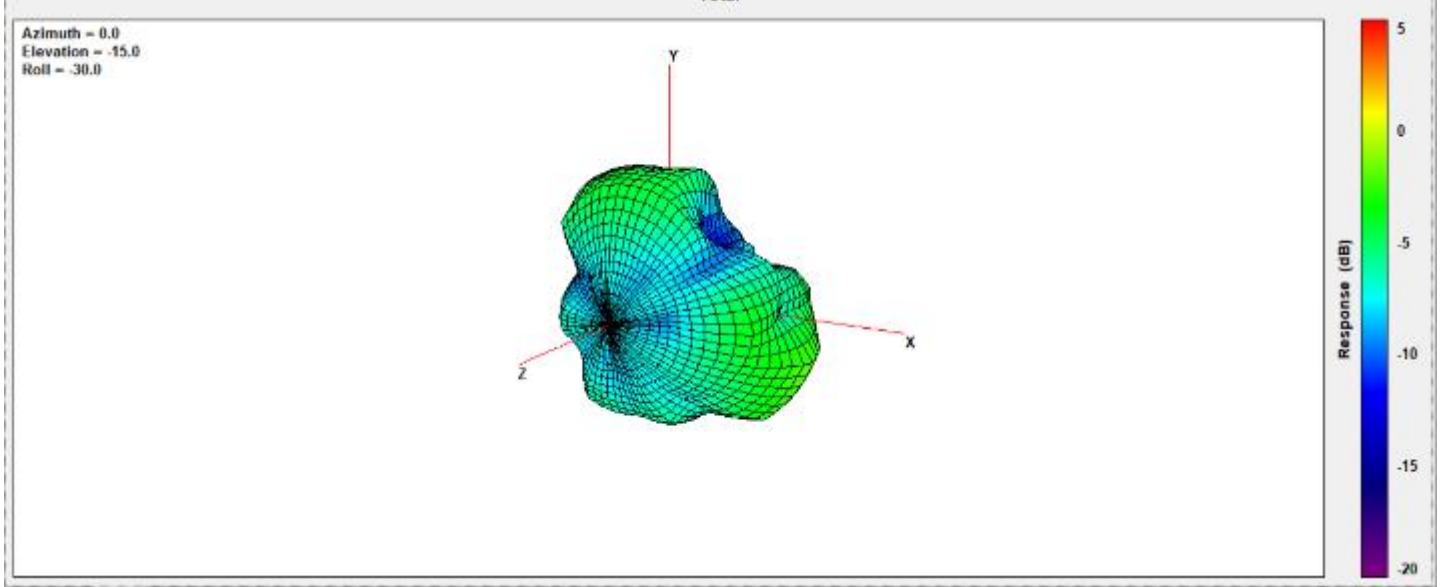

Center Frequency	1805 MHz
Horizontal (dBi) peak	-4.33
Vertical (dBi) peak	-2.41

1850 MHz

Total

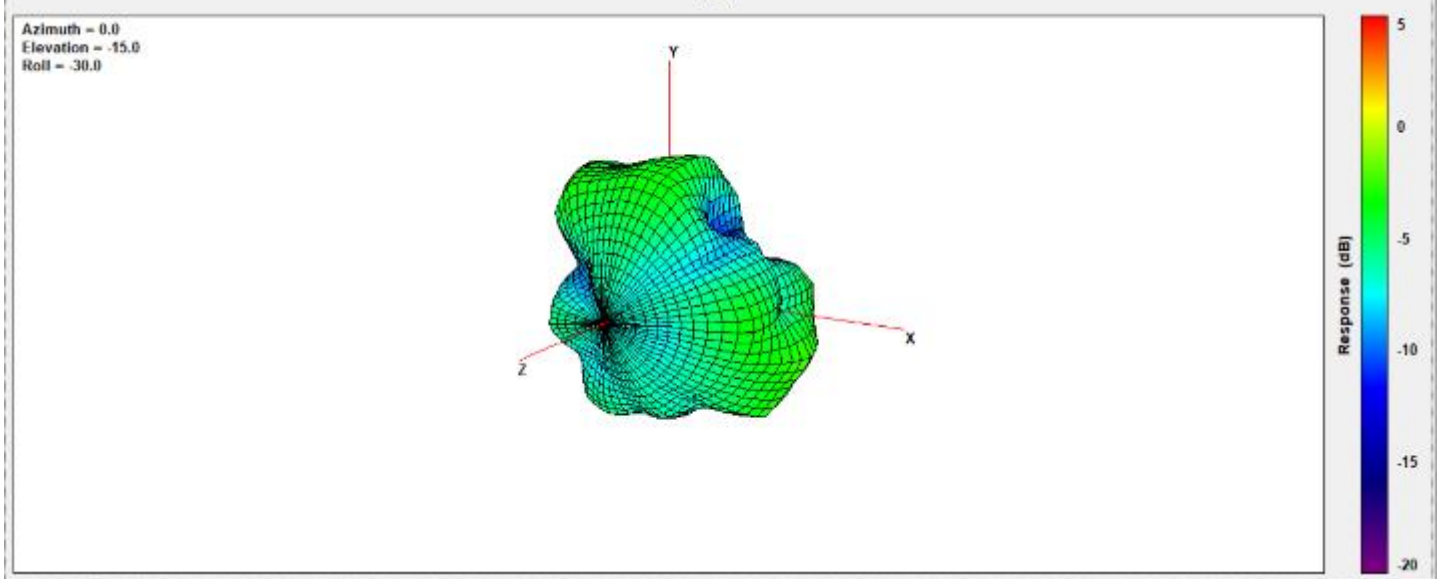

Center Frequency	1850 MHz
Horizontal (dBi) peak	-4.11
Vertical (dBi) peak	-2.64

1880 MHz

Total

Azimuth = 0.0
Elevation = -15.0
Roll = -30.0

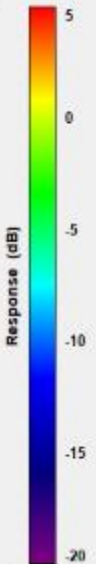
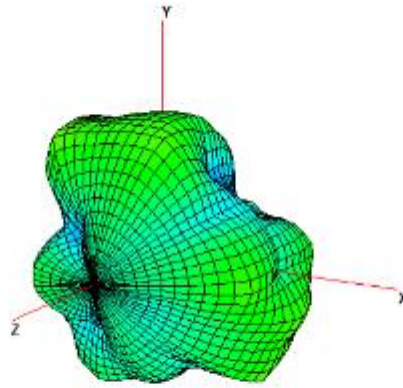

Center Frequency	1880 MHz
Horizontal (dBi) peak	-3.44
Vertical (dBi) peak	-2.49

1910MHz

Total

Azimuth = 0.0
Elevation = -15.0
Roll = -30.0

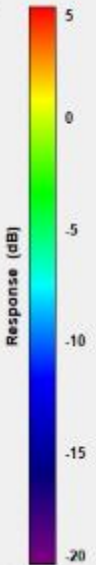
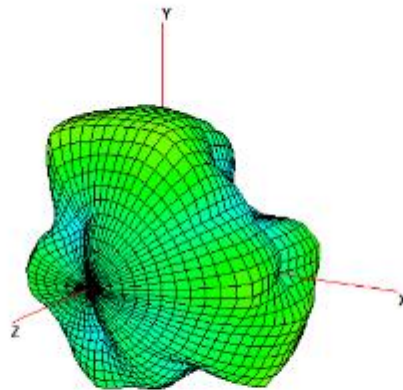

Center Frequency	1910MHz
Horizontal (dBi) peak	-2.26
Vertical (dBi) peak	-2.07

1920MHz

Total

Azimuth = 0.0
Elevation = -15.0
Roll = -30.0

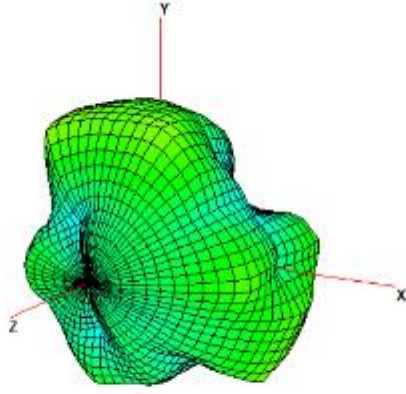

Center Frequency	1920MHz
Horizontal (dBi) peak	-2.08
Vertical (dBi) peak	-2.07

1950MHz

Total

Azimuth = 0.0
Elevation = -15.0
Roll = -30.0

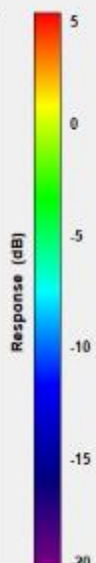
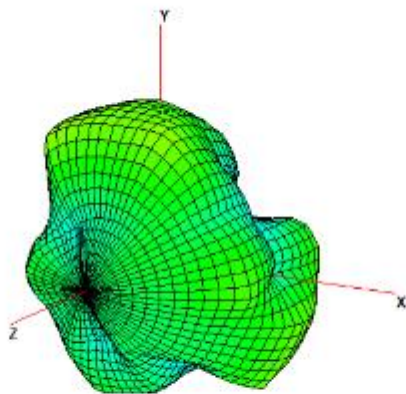

Center Frequency	1950MHz
Horizontal (dBi) peak	-1.75
Vertical (dBi) peak	-2.10

1980MHz

Total

Azimuth = 0.0
Elevation = -15.0
Roll = -30.0

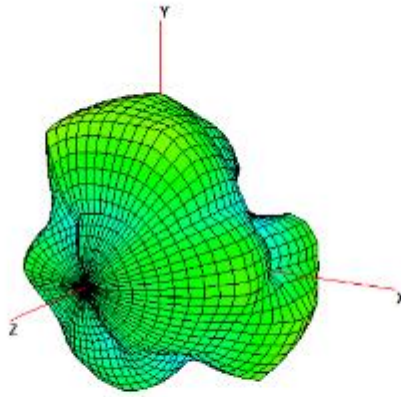

Center Frequency	1980MHz
Horizontal (dBi) peak	-1.83
Vertical (dBi) peak	-2.32

2110MHz

Total

Azimuth = 0.0
Elevation = -15.0
Roll = -30.0

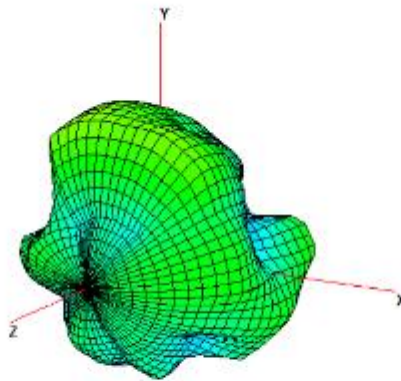

Center Frequency	2110MHz
Horizontal (dBi) peak	-2.06
Vertical (dBi) peak	-3.05

2200MHz

Total

Azimuth = 0.0
Elevation = -15.0
Roll = -30.0

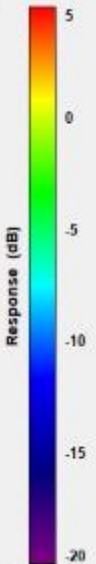
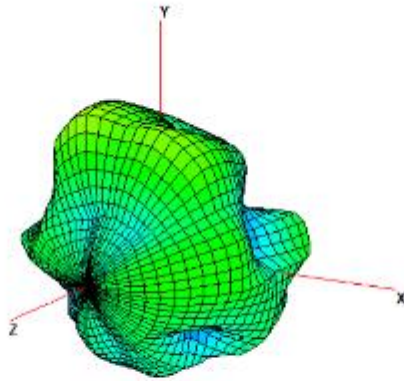

Center Frequency	2200MHz
Horizontal (dBi) peak	-1.54
Vertical (dBi) peak	-3.29

2300MHz

Total

Azimuth = 0.0
Elevation = -15.0
Roll = -30.0

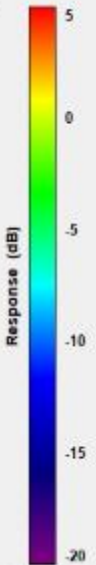
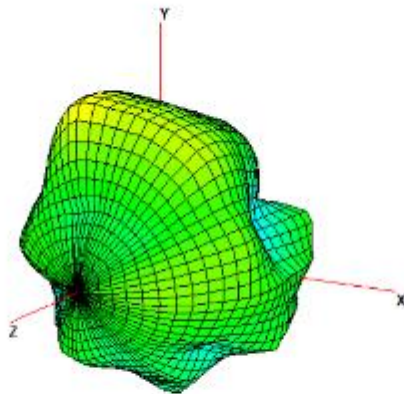

Center Frequency	2300MHz
Horizontal (dBi) peak	-0.16
Vertical (dBi) peak	-2.31

2305MHz

Total

Azimuth = 0.0
Elevation = -15.0
Roll = -30.0

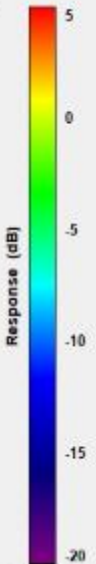
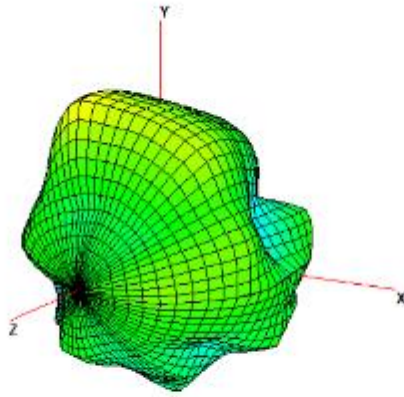

Center Frequency	2305MHz
Horizontal (dBi) peak	-0.29
Vertical (dBi) peak	-2.46

2315MHz

Total

Azimuth = 0.0
Elevation = -15.0
Roll = -30.0

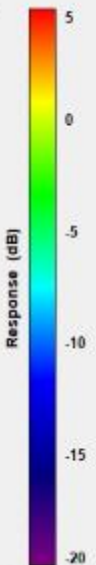
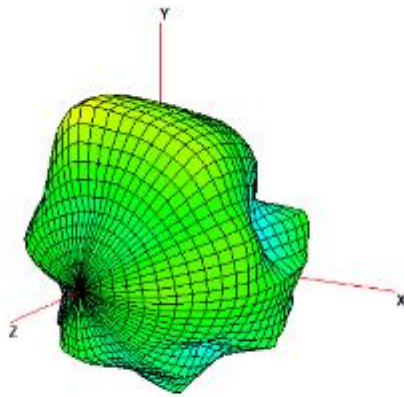

Center Frequency	2315MHz
Horizontal (dBi) peak	-0.54
Vertical (dBi) peak	-2.83

2350MHz

Total

Azimuth = 0.0
Elevation = -15.0
Roll = -30.0

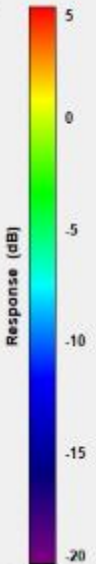
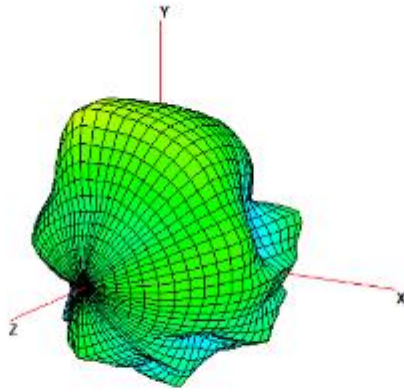

Center Frequency	2350MHz
Horizontal (dBi) peak	-1.19
Vertical (dBi) peak	-3.95

2400MHz

Total

Azimuth = 0.0
Elevation = -15.0
Roll = -30.0

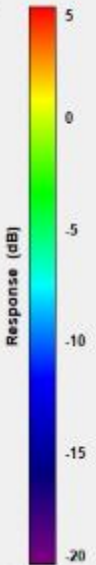
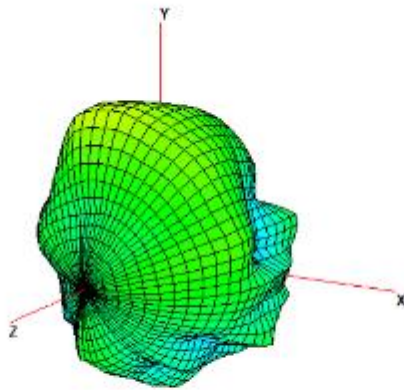

Center Frequency	2400MHz
Horizontal (dBi) peak	-0.88
Vertical (dBi) peak	-3.94

2500MHz

Total

Azimuth = 0.0
Elevation = -15.0
Roll = -30.0

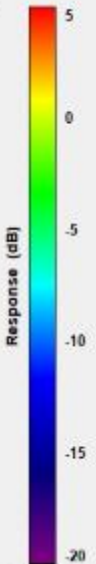
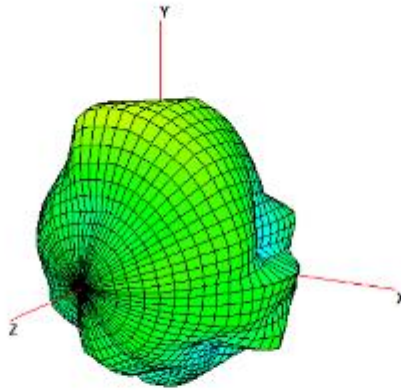

Center Frequency	2500MHz
Horizontal (dBi) peak	-0.65
Vertical (dBi) peak	-3.29

2570MHz

Total

Azimuth = 0.0
Elevation = -15.0
Roll = -30.0

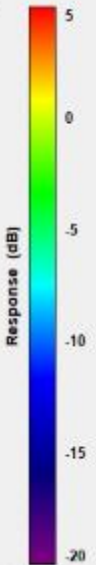
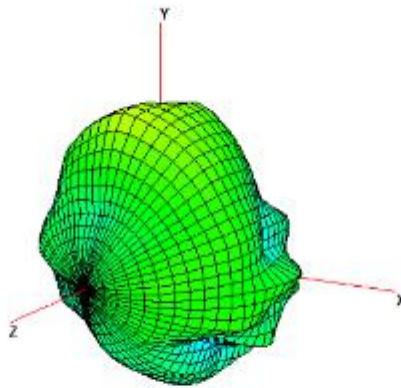

Center Frequency	2570MHz
Horizontal (dBi) peak	-0.63
Vertical (dBi) peak	-3.87

2595MHz

Total

Azimuth = 0.0
Elevation = -15.0
Roll = -30.0

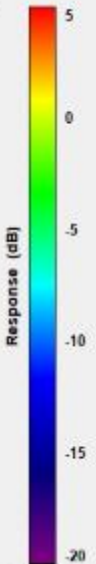
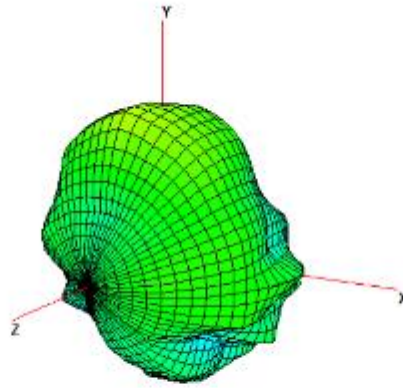

Center Frequency	2595MHz
Horizontal (dBi) peak	-0.78
Vertical (dBi) peak	-4.44

2620MHz

Total

Azimuth = 0.0
Elevation = -15.0
Roll = -30.0

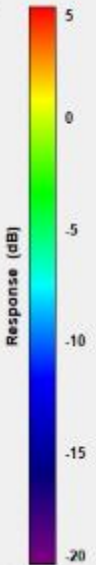
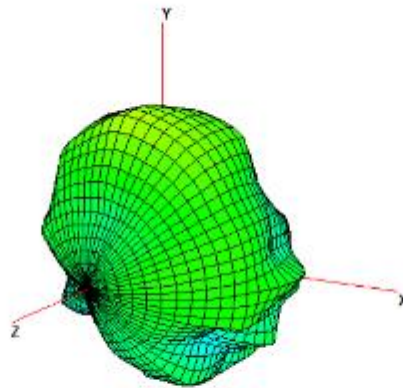

Center Frequency	2620MHz
Horizontal (dBi) peak	-0.86
Vertical (dBi) peak	-4.20

2690MHz

Total

Azimuth = 0.0
Elevation = -15.0
Roll = -30.0

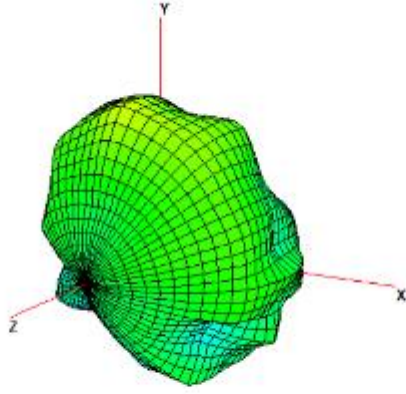

Center Frequency	2690MHz
Horizontal (dBi) peak	-0.40
Vertical (dBi) peak	-3.31

3400MHz

Total

Azimuth = 0.0
Elevation = -15.0
Roll = -30.0

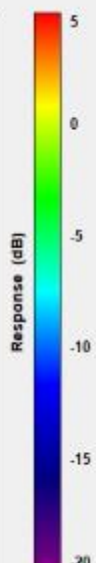
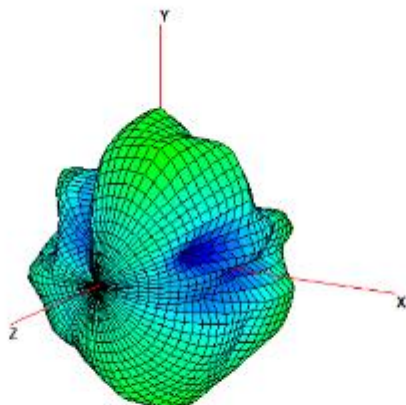

Center Frequency	3400MHz
Horizontal (dBi) peak	-3.30
Vertical (dBi) peak	-4.75

3500MHz

Total

Azimuth = 0.0
Elevation = -15.0
Roll = -30.0

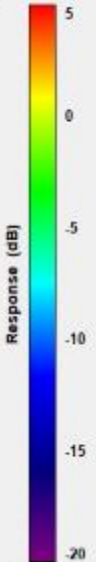
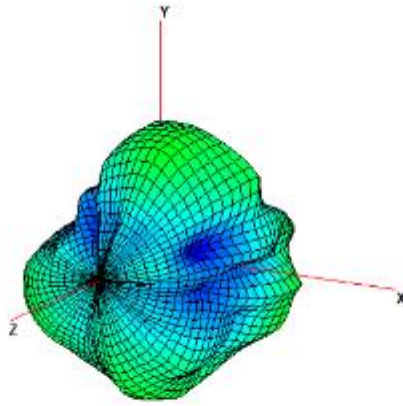

Center Frequency	3500MHz
Horizontal (dBi) peak	-3.04
Vertical (dBi) peak	-4.46

3600MHz

Total

Azimuth = 0.0
Elevation = -15.0
Roll = -30.0

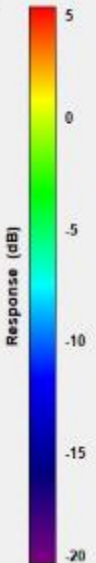
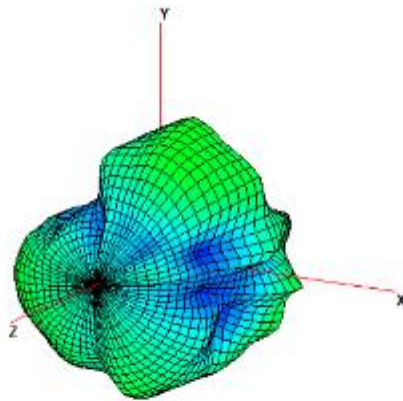

Center Frequency	3600MHz
Horizontal (dBi) peak	-4.29
Vertical (dBi) peak	-3.26

3700MHz

Total

Azimuth = 0.0
Elevation = -15.0
Roll = -30.0

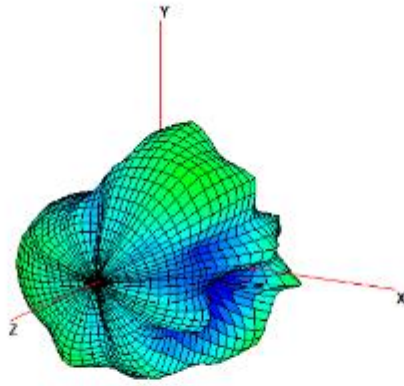

Center Frequency	3700MHz
Horizontal (dBi) peak	-3.89
Vertical (dBi) peak	-3.94

3800MHz

Total

Azimuth = 0.0
Elevation = -15.0
Roll = -30.0

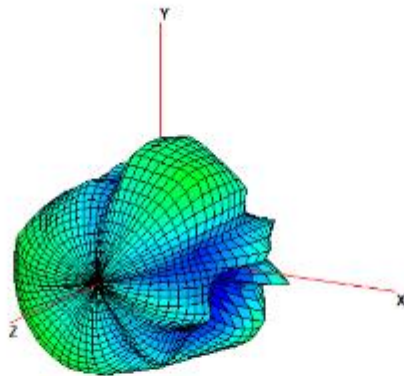

Center Frequency	3800MHz
Horizontal (dBi) peak	-3.25
Vertical (dBi) peak	-2.62

4200MHz

Total

Azimuth = 0.0
Elevation = -15.0
Roll = -30.0

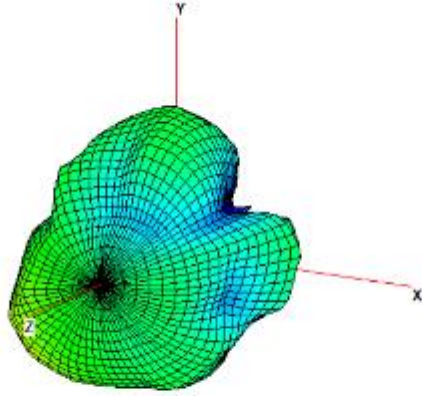

Center Frequency	4200MHz
Horizontal (dBi) peak	-2.88
Vertical (dBi) peak	-0.18

4400MHz

Total

Azimuth = 0.0
Elevation = -15.0
Roll = -30.0

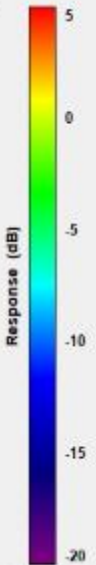
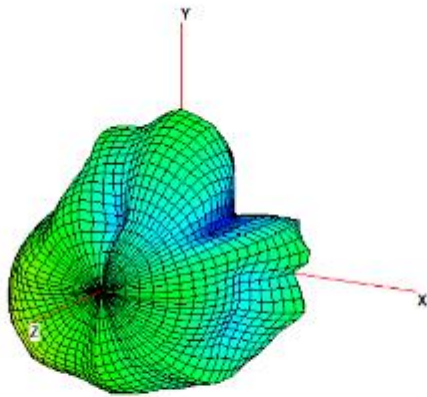

Center Frequency	4400MHz
Horizontal (dBi) peak	-3.48
Vertical (dBi) peak	-0.12

4700MHz

Total

Azimuth = 0.0
Elevation = -15.0
Roll = -30.0

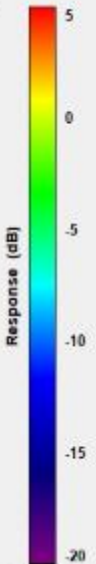
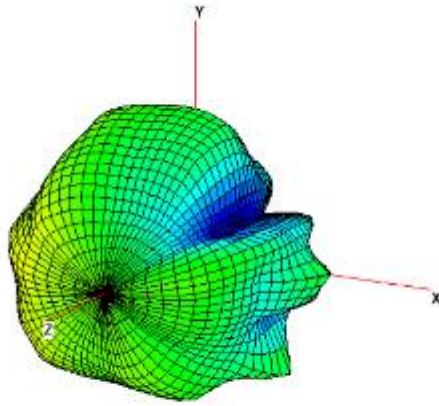

Center Frequency	4700MHz
Horizontal (dBi) peak	-2.49
Vertical (dBi) peak	0.17

5000MHz

Total

Azimuth = 0.0
Elevation = -15.0
Roll = -30.0

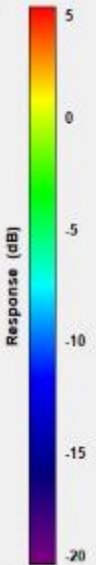
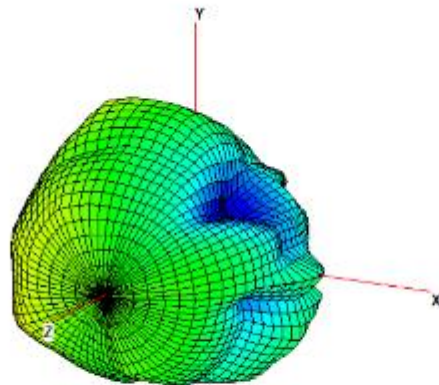

Center Frequency	5000MHz
Horizontal (dBi) peak	-1.72
Vertical (dBi) peak	-0.34

Section 4. Antenna Host Platform Location Information

Include a **dimensioned photo(s) or dimensioned drawing(s)** of Main and Aux antenna placements (measurements are not required for receive-only antenna).

Any antenna that transmits must show dimensions to bottom of laptop. Provide a description of the materials that are used for supporting or surrounding transmit antennas; for example, non-conductive plastics vs. conductive coated plastic or metallic materials.

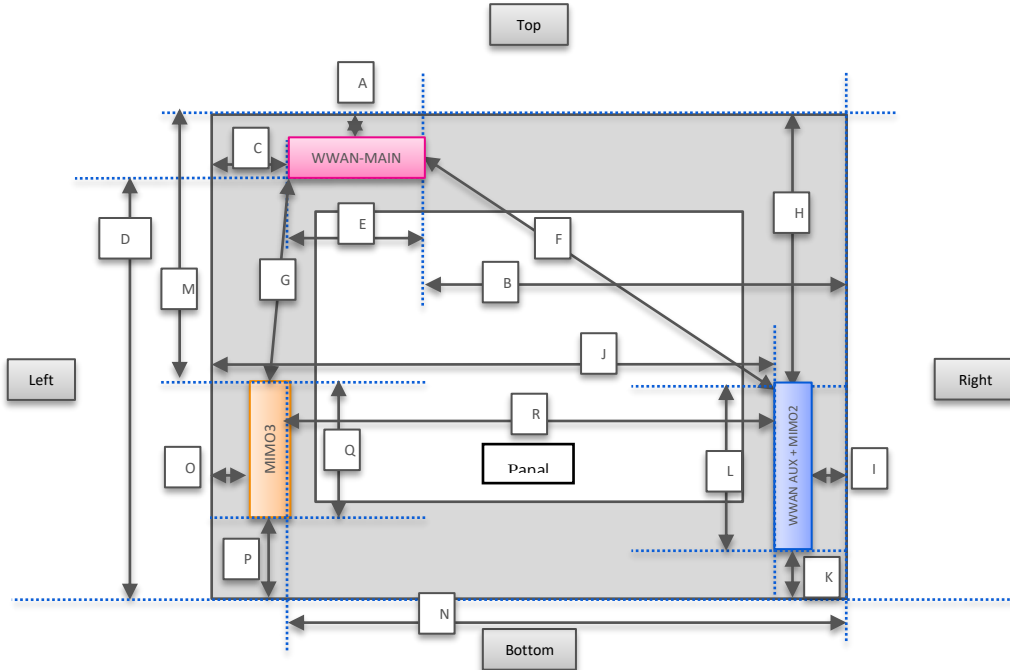

Minimum Separation Distance			
Item	Antenna	Position	Distance (mm)
A	WWAN-Main	to Top	2.1
B	WWAN-Main	to Right	191
C	WWAN-Main	to Left	24
D	WWAN-Main	to Bottom	190
E	WWAN-Main	Main Antenna Length	79
F	Main-Aux	Main to Aux	204
G	Main-MIMO3	Main-MIMO3	120
H	WWAN-AUX	to Top	113
I	WWAN-AUX	to Right	4.1
J	WWAN-AUX	to Left	281
K	WWAN-AUX	to Bottom	17
L	WWAN-AUX	Aux Antenna Length	74.6
M	WWAN-MIMO3	to Top	130
N	WWAN-MIMO3	to Right	284.5
O	WWAN-MIMO3	to Left	4.1
P	WWAN-MIMO3	to Bottom	16.8
Q	WWAN-MIMO3	MIMO3 Antenna Length	61.2

R	AUX-MIMO3	AUX-MIMO3	270
S	WWAN--Main	to Front	2.5
T	WWAN--Main	to Rear	6.9
U	WWAN--Aux	to Front	2.55
V	WWAN-Aux	to Rear	6.9
W	WWAN-MIMO3	to Front	2.55
X	WWAN-MIMO3	to Rear	6.9

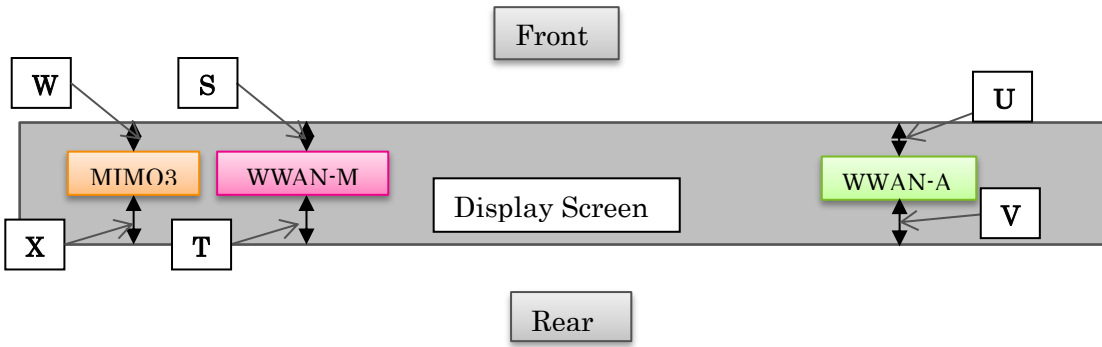

Section 5. Antenna dimensional information for SAR evaluation

Include a **dimensioned photo(s) or dimensioned drawing(s)** showing the distance (mm) between the transmit antennas and the user. For notebook/laptop hosts show lapheld position (example below). For tablet hosts show all orientations including lapheld, primary & secondary portrait, primary & secondary landscape positions. Include a description of any proximity sensors or power throttling implementations that limit or exclude use of any host orientation.

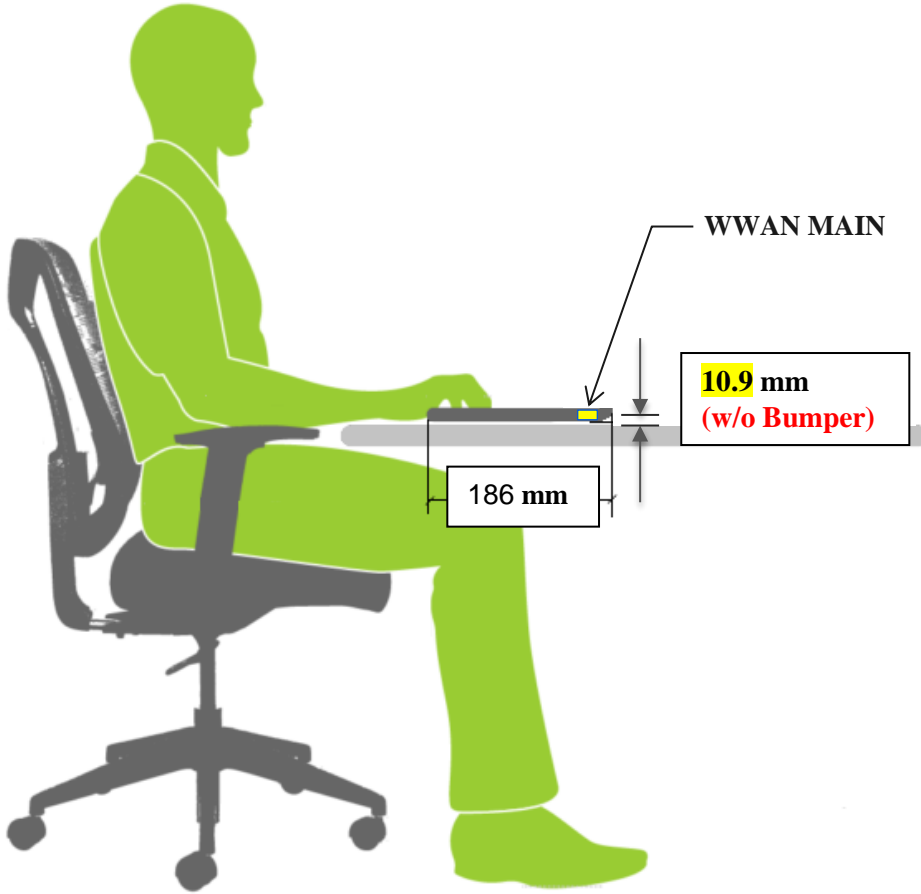

Section 6. Diagram Example of Co-Location Antenna Separation

Include a **dimensioned photo or dimensioned drawing** showing the distance (mm) between **all WLAN transmit antennas** and other co-located radiator transmit antenna such as Bluetooth, WWAN,..

(Note: Due to the evolving rules regarding co-location, each platform will need to be reviewed on a case by case basis)

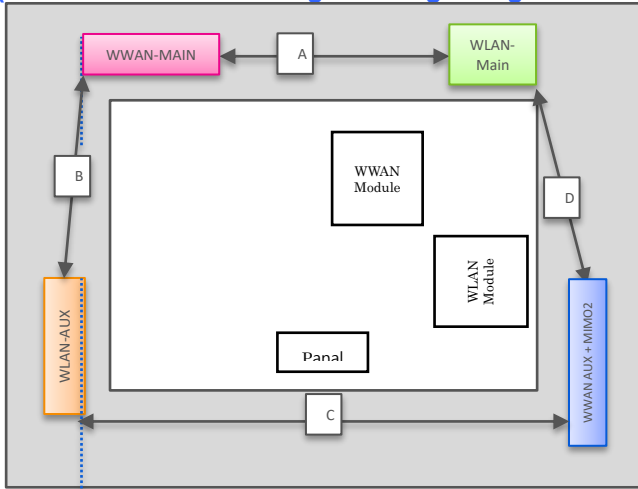

Minimum Separation Distance

Item	Antenna	between	Distance (mm)
A	WLAN-Main	WWAN MAIN	147
B	WWAN-Main	WLAN -AUX	116
C	WLAN-Aux	MIMO2	268
D	MIMO2	WLAN-Main	92