

# Regulatory WWAN Antenna Information

(English Language Required for Intel Regulatory Review / Approval)

**(OEM/ODM or antenna vendor is required to complete this document with platform antenna information. Remove Intel references and make this your own document)**

<b>Platform</b>	
Platform Owner	DELL
Brand Name	DELL
Model Name	T06H
ODM	Compal Electronics, Inc.
Target Launch Date	2022/07/26
<b>Antenna</b>	
Manufacturer	Auden Techno Corp.
Part Number	■ Tx1/Rx1 <u>Antenna</u> WWAN Main; B32515-00 (DC33002P40L)
	■ Rx2 Antenna WWAN Aux; B32516-00 (DC33002P41L)
	■ Tx2/Rx3 Antenna MIMO2; B32516-00 (DC33002P41L)
	■ Rx4 Antenna MIMO3; B325122-30 (DC33002P47L)
<b>Module</b>	
With WWAN Module	Foxconn T99W175/T77W968
(Check Box)	

## Antenna Sample / Antenna Data Requirements for worldwide regulatory approval

Section	Description of Required OEM / ODM Antenna Information	US / IC	EU	Japan	Taiwan	S.Korea
1A	Part Number for Antenna only	Required	Required	Required	Required	Required
1B	Antenna Manufacturer Name	Required	Required	Required	Required	Required
1C	Description of Antenna Type	Required	N/A	N/A	N/A	N/A
1D	Part number of Antenna Assembly / cable impedance, length & diameter.	Required	Desired	Desired	Desired	Desired
1E	Tx1, Tx2 & Tx3 antenna (Peak Gain W/ cable loss) *	Required	Required	Required	Required	Required
	1E OR 1F, 1G, 1H					
1F	Tx1, Tx2 & Tx3 antenna (Peak Gain only) *	Required	Required	Required	Required	Required
1G	VSWR of cable including connector	Required	Required	Required	Required	Required
1H	Tx1, Tx2 & Tx3 antenna (Cable loss W/ connector) *	Required	Required	Required	Required	Required
2	Dimensioned Photographs and Drawings of Tx1, Tx2, and Tx3 (or Rx3) antennas	Required	Required	Required	Required	Required
3	Radiation patterns of antennas loaded in the host platform.	Required	Desired	Required	N/A	Required
4	Platform model name / number - correlated to antenna manufacturer and antenna part number	Required	Required	Desired	Required	Desired
5	Photograph(s) or Drawings showing location of antennas in platform. <u>(S. Korea requires photographs of antennas for approval submission). Taiwan requires pictures of each antenna type shown in the system.</u>	Required	Required	Desired	<u>Required (Photos)</u>	<u>Required (Photos)</u>
6	Mech. drawings / photos with dimensions of antenna locations and distance from end-user (For evaluation of SAR testing requirement).	Required	N/A	N/A	N/A	N/A
7	Photograph(s) or Drawings showing the location of all antennas (WLAN, other) and distance between those transmitting antennas. Information will be used to evaluate whether co-location testing is required.	Required	N/A	N/A	N/A	N/A
8	Local representative contact information for LMA/ PARS process.	Required	N/A	N/A	N/A	N/A

# Table of contents

1. Applicable test method
2. Test & System Description
  - a. Test setup
  - b. Equipment list
3. Setup photo

[Section 1. Antenna Assembly Specifications](#)

[Section 2. Dimensioned Photos or Drawings of Antennas](#)

[Section 3. Radiation characteristics of antenna loaded in Host Platform](#)

[Section 4. Antenna Host Platform Location Information](#)

[Section 5. Antenna dimensional information for SAR evaluation](#)

[Section 6. Diagram Example of Co-Location Antenna Separation](#)

1. **Applicable test methods**

<insert test description here for test method>

This test report is prepared for host antenna testing under a Full Anechoic Chamber.

2. **Test & System Description**

a. Test setup

<insert test diagram here for test site utilized>

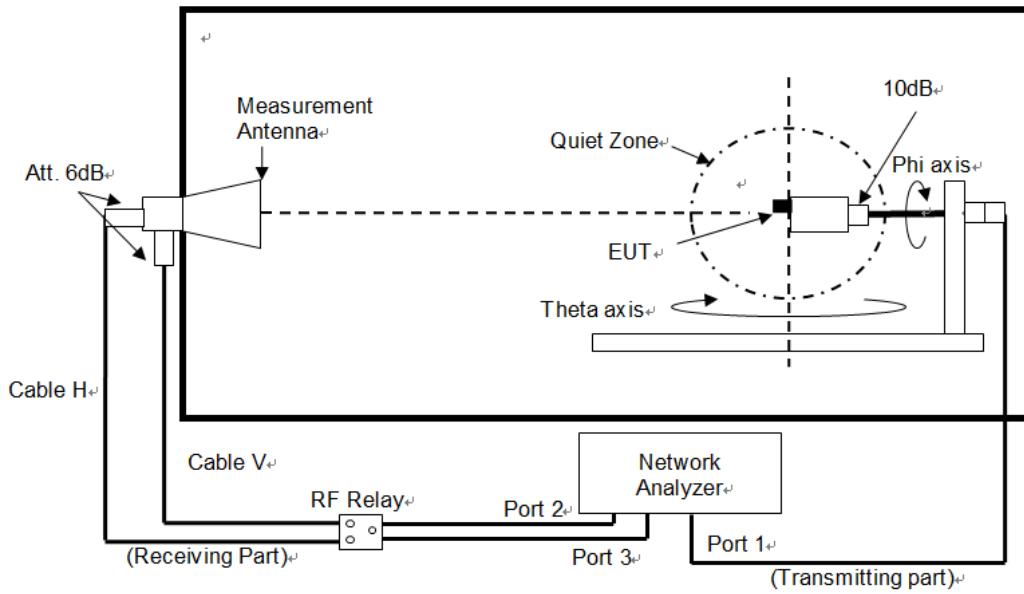

## b. Equipment list

&lt;insert test diagram here for test site utilized&gt;

Name	Manufacturer	Type/Model	Serial Number
ENA Series Network Analyzer	Keysight	E5080B	MY59101211
RF Switch	Keysight	3499A	MY42000955
Multi-Axis Positioner Controller	ETS-Lindgren	2090	N/A
Medium-Duty Positioner	ETS-Lindgren	2015	N/A
Measurement Horn Antenna	EMCO	3164-08	00086722

**3. Setup photo**



# Antenna Information

## Section 1. Antenna Assembly Specifications

1A	1B	1C	1D	1E	1F	1G	1H
Antenna Part Number	Manufacture	Antenna Type	Cable Assembly Part Number and Information	*Peak Gain W/ Cable loss (dBi)	Peak Gain w/o Cable Loss (dBi)	VSWR	Cable Loss (dBi)
P/N: B32515-00 (DC33002P40L) Tx1/ Rx1 Antenna	Auden Techno Corp.	PIFA	(1) Cable P/N: SY113L/50-146  (2) Cable length: 99mm diameter: 1.13mm 50 ohm Coaxial  (3)Connector P/N: I-PEX MHF4	698-821MHz	698-821MHz	698-821MHz	698-821MHz
				-1.29 dBi (peak)	-1.18 dBi (peak)	3.0 max	0.11 dBi (peak)
				824-960MHz	824-960MHz	824-960MHz	824-960MHz
				0.96 dBi (peak)	1.09 dBi (peak)	3.0 max	0.13 dBi (peak)
				1425-1515MHz	1425-1515MHz	1425-1515MHz	1425-1515MHz
				-0.32 dBi (peak)	-0.16 dBi (peak)	3.0 max	0.16 dBi (peak)
				1710-2200MHz	1710-2200MHz	1710-2200MHz	1710-2200MHz
				0.83 dBi (peak)	1.01 dBi (peak)	3.0 max	0.18 dBi (peak)
P/N: B32516-00 (DC33002P41L) Rx2 Antenna	Auden Techno Corp.	PIFA	(1) Cable P/N: SY113L/50-145  (2) Cable length: 237mm diameter: 1.13mm 50 ohm Coaxial  (3)Connector P/N: I-PEX MHF4	2300-2690MHz	2300-2690MHz	2300-2690MHz	2300-2690MHz
				0.46 dBi (peak)	0.66 dBi (peak)	3.0 max	0.20 dBi (peak)
				3400-3800MHz	3400-3800MHz	3400-3800MHz	3400-3800MHz
				-1.50 dBi (peak)	-1.23 dBi (peak)	3.0 max	0.27 dBi (peak)
				4200-4700MHz	4200-4700MHz	4200-4700MHz	4200-4700MHz
				0.38 dBi (peak)	0.68 dBi (peak)	3.0 max	0.30 dBi (peak)
				5150-5925MHz	5150-5925MHz	5150-5925MHz	5150-5925MHz
				1.82 dBi (peak)	2.16 dBi (peak)	3.0 max	0.34 dBi (peak)
P/N: B32516-00 (DC33002P41L) Rx2 Antenna	Auden Techno Corp.	PIFA	(1) Cable P/N: SY113L/50-145  (2) Cable length: 237mm diameter: 1.13mm 50 ohm Coaxial  (3)Connector P/N: I-PEX MHF4	717-821MHz	717-821MHz	717-821MHz	717-821MHz
				-0.37 dBi (peak)	-0.09 dBi (peak)	3.0 max	0.28 dBi (peak)
				824-960MHz	824-960MHz	824-960MHz	824-960MHz
				-1.54 dBi (peak)	-1.22 dBi (peak)	3.0 max	0.32 dBi (peak)
				1425-1515MHz	1425-1515MHz	1425-1515MHz	1425-1515MHz
				-0.45 dBi (peak)	-0.08 dBi (peak)	3.0 max	0.37 dBi (peak)
				1557-1610 MHz	1557-1610 MHz	1557-1610 MHz	1557-1610 MHz
				-1.95 dBi (peak)	-1.54 dBi (peak)	3.0 max	0.41 dBi (peak)
P/N: B32516-00 (DC33002P41L) Rx2 Antenna	Auden Techno Corp.	PIFA	(1) Cable P/N: SY113L/50-145  (2) Cable length: 237mm diameter: 1.13mm 50 ohm Coaxial  (3)Connector P/N: I-PEX MHF4	1805-2200MHz	1805-2200MHz	1805-2200MHz	1805-2200MHz
				-0.85 dBi (peak)	-0.43 dBi (peak)	3.0 max	0.42 dBi (peak)
				2300-2690MHz	2300-2690MHz	2300-2690MHz	2300-2690MHz
				0.32 dBi (peak)	0.80 dBi (peak)	3.0 max	0.48 dBi (peak)
				3400-3800MHz	3400-3800MHz	3400-3800MHz	3400-3800MHz
				-1.48 dBi (peak)	-0.84 dBi (peak)	3.0 max	0.64 dBi (peak)
				4200-4700MHz	4200-4700MHz	4200-4700MHz	4200-4700MHz
				-0.65 dBi (peak)	0.07 dBi (peak)	3.0 max	0.72 dBi (peak)
P/N: B32516-00 (DC33002P41L) Rx2 Antenna	Auden Techno Corp.	PIFA	(1) Cable P/N: SY113L/50-145  (2) Cable length: 237mm diameter: 1.13mm 50 ohm Coaxial  (3)Connector P/N: I-PEX MHF4	5150-5925MHz	5150-5925MHz	5150-5925MHz	5150-5925MHz
				-0.02 dBi (peak)	0.80 dBi (peak)	3.0 max	0.82 dBi (peak)

1A Antenna Part Number	1B Manufacture	1C Antenna Type	1D Cable Assembly Part Number and Information	1E *Peak Gain W/ Cable loss (dBi)	1F Peak Gain w/o Cable Loss (dBi)	1G VSWR	1H Cable Loss (dBi)
P/N: B32516-00 (DC33002P41L) Tx2/ Rx3 Antenna	Auden Techno Corp.	PIFA	(1) Cable P/N: SY113L/50-164  (2) Cable length: 318mm diameter: 1.13mm 50 ohm Coaxial  (3)Connector P/N: I-PEX MHF4	1710-2200MHz 0.79 dBi (peak)	1710-2200MHz 1.19 dBi (peak)	1710-2200MHz 3.0 dBi (peak)	1710-2200MHz 0.40 dBi (peak)
				2300-2690MHz 2.12 dBi (peak)	2300-2690MHz 2.58 dBi (peak)	2300-2690MHz 3.0 dBi (peak)	2300-2690MHz 0.46 dBi (peak)
				3400-3800MHz 0.82 dBi (peak)	3400-3800MHz 1.44 dBi (peak)	3400-3800MHz 3.0 dBi (peak)	3400-3800MHz 0.62 dBi (peak)
				4200-5000MHz -0.08 dBi (peak)	4200-5000MHz 0.61 dBi (peak)	4200-5000MHz 3.0 dBi (peak)	4200-5000MHz 0.69 dBi (peak)
P/N: B32522-30 (DC33002P47L) Rx4 Antenna	Auden Techno Corp.	PIFA	(1) Cable P/N: SY113L/50-160  (2) Cable length: 228mm diameter: 1.13mm 50 ohm Coaxial  (3)Connector P/N: I-PEX MHF4	1805-2200MHz -0.89 dBi (peak)	1805-2200MHz -0.33 dBi (peak)	1805-2200MHz 3.0 dBi (peak)	1805-2200MHz 0.56 dBi (peak)
				2300-2690MHz 0.49 dBi (peak)	2300-2690MHz 1.14 dBi (peak)	2300-2690MHz 3.0 dBi (peak)	2300-2690MHz 0.65 dBi (peak)
				3400-3800MHz -1.78 dBi (peak)	3400-3800MHz -0.92 dBi (peak)	3400-3800MHz 3.0 dBi (peak)	3400-3800MHz 0.86 dBi (peak)
				4200-5000MHz 1.10 dBi (peak)	4200-5000MHz 2.06 dBi (peak)	4200-5000MHz 3.0 dBi (peak)	4200-5000MHz 0.96 dBi (peak)

- Antenna Peak Gain required being test in system basis.
- 1E frame contend absolutely peak antenna gain include H/V



## Antenna Peak Gain Table: Low and middle band

Frequency (MHz)	Tx1 / Rx1 antenna		Rx2 antenna	
	Horizontal	Vertical	Horizontal	Vertical
	(dBi)	(dBi)	(dBi)	(dBi)
698	-3.88	-1.69		
703	-3.62	-1.50		
707.5	-3.49	-1.49		
717	-3.25	-1.61	-0.91	-0.49
725.5	-2.91	-1.68	-0.76	-0.52
748	-1.94	-1.94	-0.64	-0.41
756	-1.61	-1.90	-0.74	-0.37
768	-1.42	-1.77	-1.31	-0.54
777	-1.71	-1.80	-2.01	-0.96
782	-1.95	-1.77	-2.34	-1.14
787	-2.19	-1.78	-2.55	-1.43
814	-2.58	-1.29	-2.30	-3.08
824	-2.19	-0.96	-2.12	-2.89
832	-1.93	-0.62	-1.87	-2.81
836.5	-1.74	-0.39	-1.84	-2.51
849	-1.08	0.36	-1.79	-1.87
862	-0.18	0.96	-1.57	-1.54
880	0.20	0.61	-1.63	-1.87
897.5	0.10	0.32	-1.98	-2.14
915	-0.30	0.21	-2.54	-2.29
925	-0.64	-0.01	-2.91	-2.30
960	-3.90	-1.46	-5.30	-3.72
1427.9	-6.18	-2.72	-4.03	-1.20
1447.9	-3.76	-1.63	-3.84	-0.71
1455.4	-2.97	-1.19	-3.68	-0.62
1462.9	-2.52	-0.84	-3.56	-0.54
1496	-2.67	-0.48	-3.84	-0.45
1510.9	-2.77	-0.32	-4.33	-0.73
1557			-4.78	-1.95
1575			-4.32	-2.46
1610			-3.45	-2.52

**High band**

Frequency (MHz)	Tx1 / Rx1 antenna		Rx2 antenna	
	Horizontal (dBi)	Vertical (dBi)	Horizontal (dBi)	Vertical (dBi)
1710	-0.82	-0.72		
1732.5	-0.12	-0.61		
1747.5	0.06	-0.82		
1755	0.06	-1.00		
1785	-0.72	-0.96		
1805	-0.96	-0.79	-4.65	-2.70
1850	-1.58	-0.92	-4.05	-2.03
1880	-0.71	-0.57	-3.41	-1.18
1910	0.22	0.13	-2.45	-0.85
1920	0.37	0.21	-2.39	-0.98
1950	0.83	0.59	-2.23	-1.48
1980	0.53	0.34	-2.49	-1.65
2110	-0.80	-1.07	-4.05	-2.36
2200	-0.49	-1.54	-4.86	-3.67
2300	0.46	-0.69	-3.19	-1.76
2305	0.25	-0.77	-3.26	-1.78
2315	-0.20	-0.73	-3.51	-1.65
2350	-1.69	-0.80	-4.31	-1.68
2400	-2.46	-0.88	-3.76	-2.32
2500	-1.61	-0.06	-4.85	-4.46
2570	-1.99	-0.80	-3.51	-2.41
2595	-1.64	-0.87	-2.78	-1.58
2620	-1.35	-0.91	-2.13	-0.76
2690	-1.05	-0.98	-0.82	0.32
3400	-1.88	-3.61	-4.98	-3.35
3500	-1.68	-3.70	-5.00	-3.15
3600	-2.06	-4.22	-4.90	-5.33
3700	-2.67	-3.72	-1.61	-2.72
3800	-1.50	-3.00	-1.68	-1.48
4200	0.38	-1.67	-1.56	-2.77
4400	-0.18	-3.07	-1.62	-2.75
4700	-0.84	-1.47	-0.65	-2.80
5150	0.87	-1.51	-0.02	-2.44
5537.5	-2.30	-0.57	-1.07	-4.05
5925	1.13	1.82	-2.04	-2.73

Frequency (MHz)	Tx2 / Rx3 antenna		Rx4 antenna	
	Horizontal (dBi)	Vertical (dBi)	Horizontal (dBi)	Vertical (dBi)
1710	0.33	0.59		
1732.5	-0.07	0.24		
1747.5	-0.76	-0.22		
1755	-1.29	-0.58		
1785	-2.19	-3.92		
1805	-1.95	-4.45	-3.77	-1.85
1850	-2.23	-2.20	-3.55	-2.08
1880	-0.48	-0.85	-2.88	-1.93
1910	0.26	-0.13	-1.70	-1.51
1920	0.04	-0.01	-1.52	-1.51
1950	0.14	0.79	-1.19	-1.54
1980	-0.78	0.62	-1.27	-1.76
2110	-2.22	-1.60	-1.41	-2.40
2200	-0.30	-0.49	-0.89	-2.64
2300	1.10	0.12	0.49	-1.66
2305	0.89	0.99	0.36	-1.81
2315	0.26	0.49	0.11	-2.18
2350	-0.12	-0.54	-0.54	-3.30
2400	-1.50	-1.48	-0.23	-3.29
2500	-0.97	0.39	0.00	-2.64
2570	1.40	1.80	0.02	-3.22
2595	0.56	1.85	-0.13	-3.79
2620	-0.97	0.81	-0.21	-3.55
2690	-5.26	-2.75	0.25	-2.66
3400	-2.90	0.44	-2.46	-3.91
3500	-2.42	0.82	-2.20	-3.62
3600	-2.01	-0.65	-3.45	-2.42
3700	-1.54	-0.98	-3.05	-3.10
3800	-0.11	-1.29	-2.41	-1.78
4200	-2.42	-4.53	-1.95	0.75
4400	-0.32	-2.34	-2.55	0.81
4700	-1.07	-0.69	-1.56	1.10
5000	-0.08	-1.10	-0.49	0.89

## Section 2. Dimensioned Photos or Drawings of Antennas

Include a dimensioned photo and dimensioned drawing of Main antenna here.

### Tx1/ Rx1 Antenna Dimensioned Drawing:

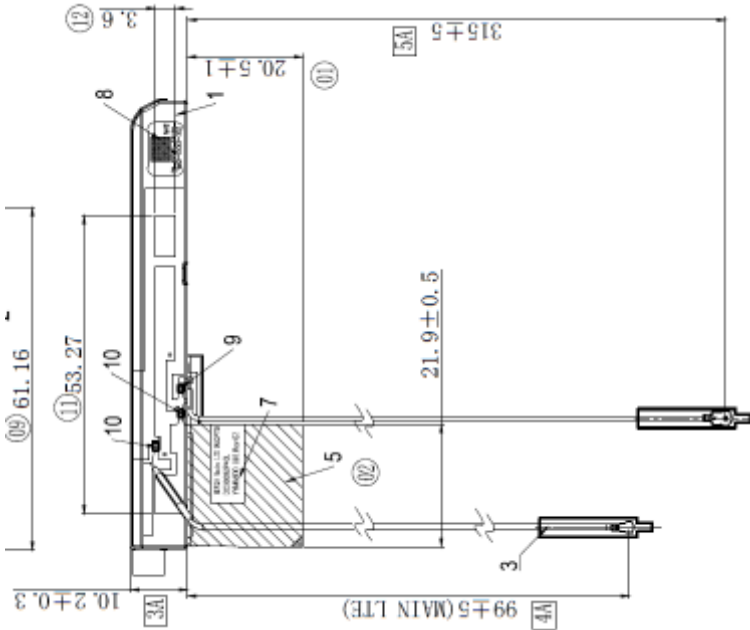

Include a dimensioned photo and dimensioned drawing of Aux antenna here.

### Rx2 Antenna Dimensioned Drawing:

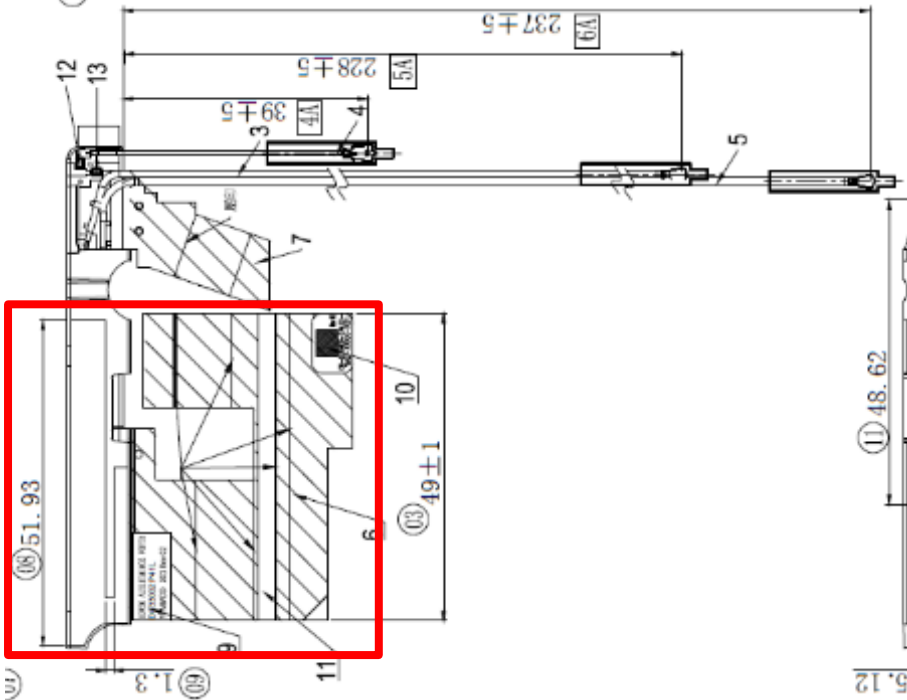

Include a dimensioned photo and dimensioned drawing of Aux antenna here.

**Tx2/ Rx3 Antenna Dimensioned Drawing:**

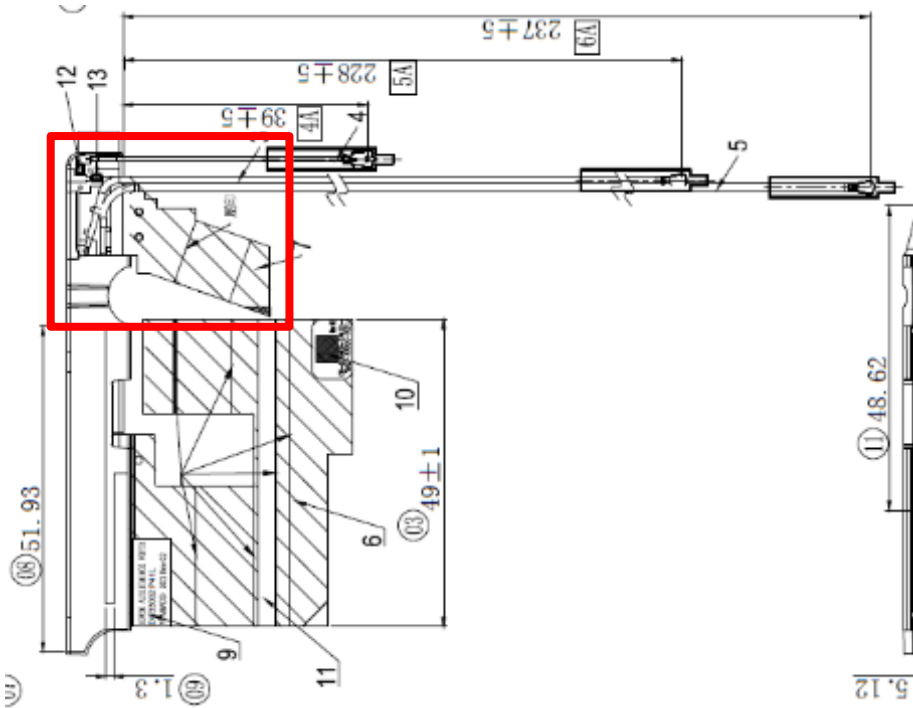

Include a dimensioned photo and dimensioned drawing of Aux antenna here.

**Rx4 Antenna Dimensioned Drawing:**

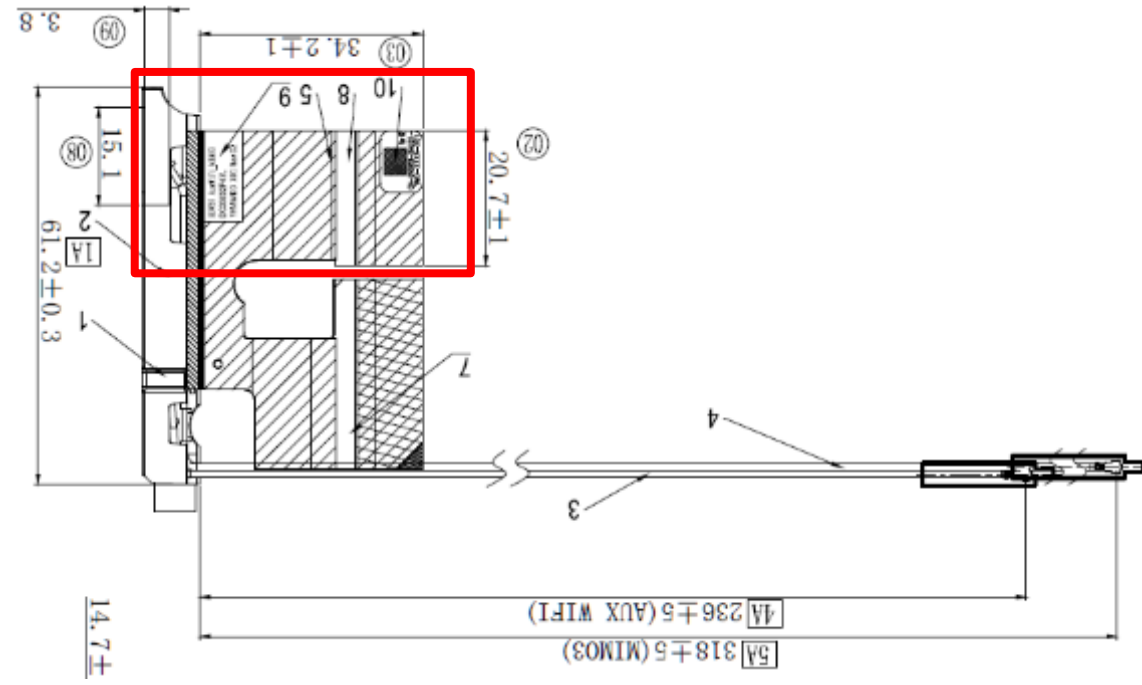

## Section 3. Radiation characteristics of antennae Loaded in Host Platform

### WWAN Main Antenna (TPx)

698MHz

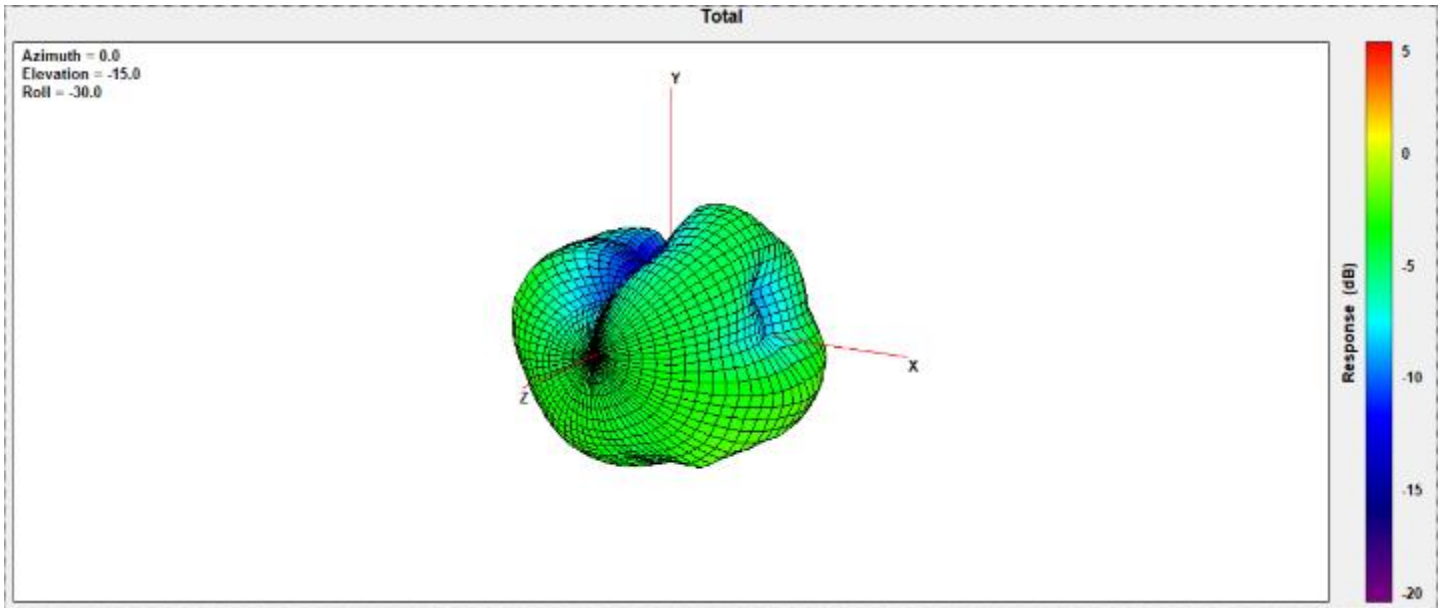

Center Frequency	<b>698 MHz</b>
Horizontal (dBi) peak	-3.88
Vertical (dBi) peak	-1.69

703MHz

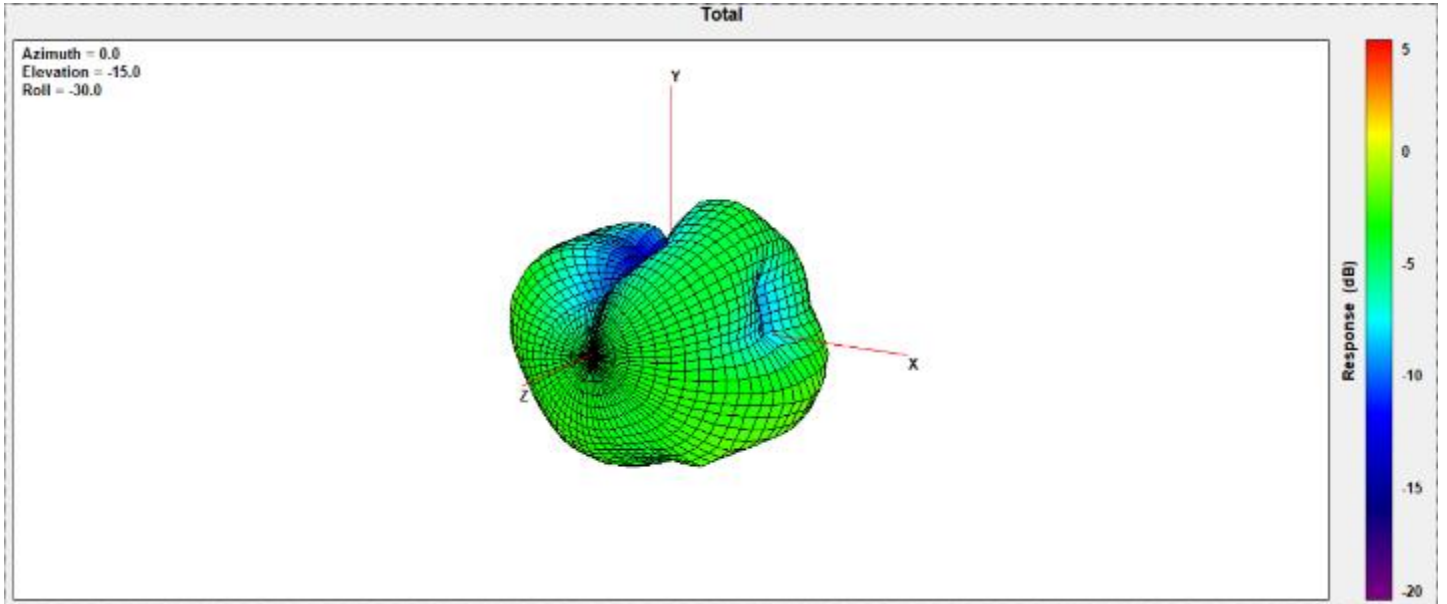

Center Frequency	<b>703MHz</b>
Horizontal (dBi) peak	-3.62
Vertical (dBi) peak	-1.50

### 707.5MHz

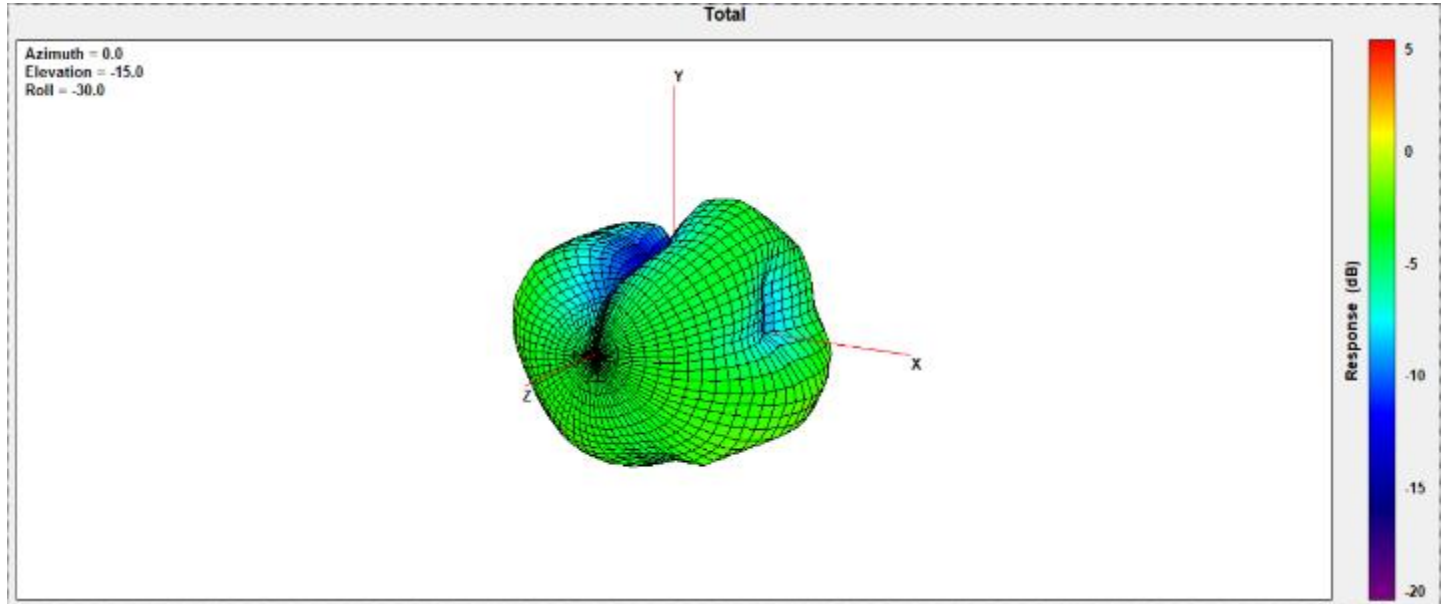

Center Frequency	<b>707.5MHz</b>
Horizontal (dBi) peak	-3.49
Vertical (dBi) peak	-1.49

### 717MHz

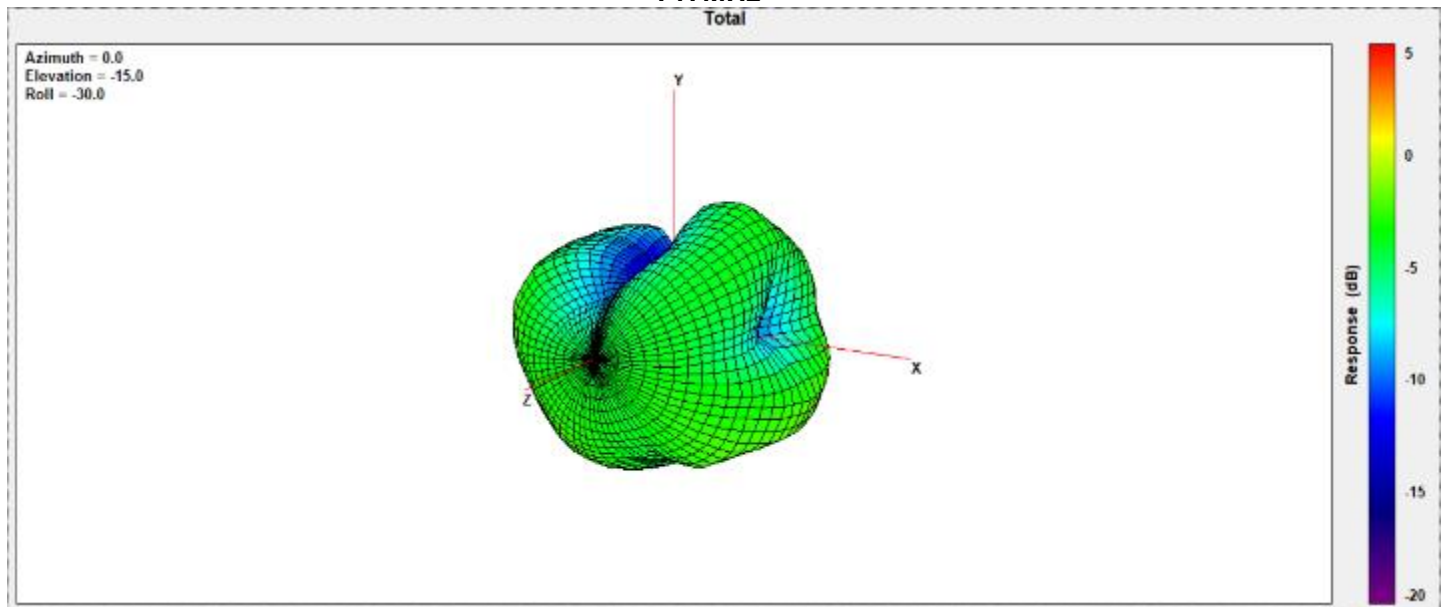

Center Frequency	<b>717MHz</b>
Horizontal (dBi) peak	-3.25
Vertical (dBi) peak	-1.61

### 725.5MHz

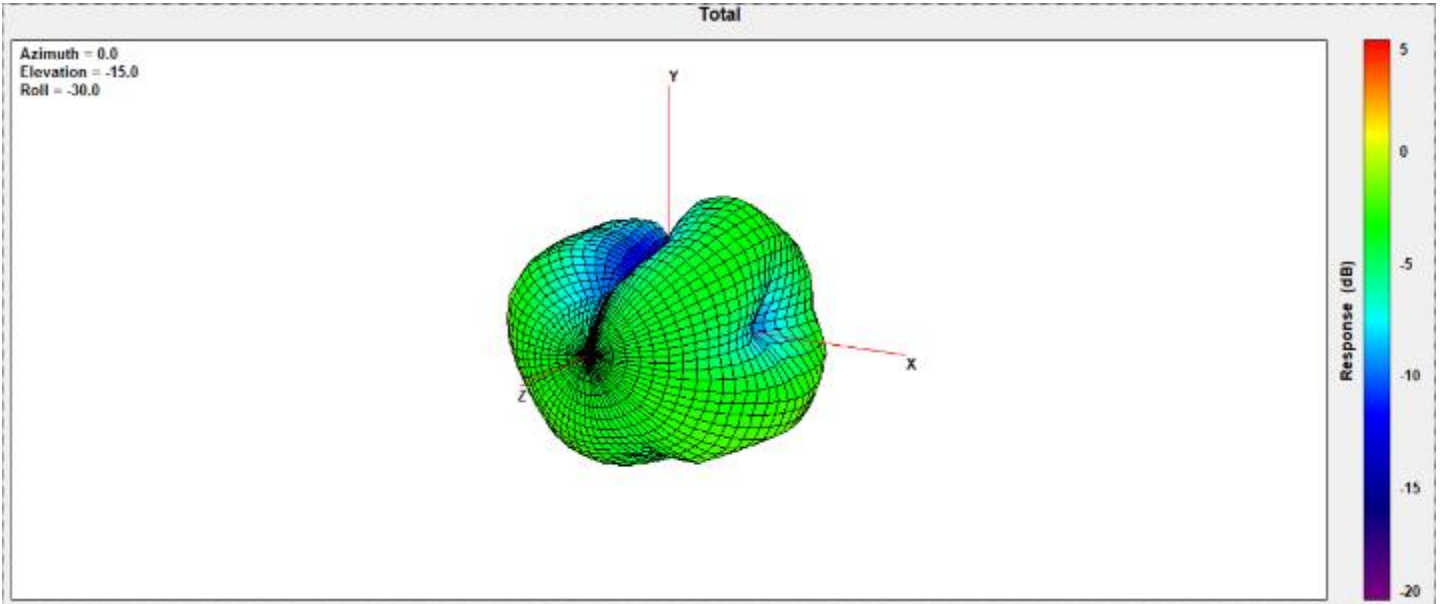

Center Frequency	<b>725.5MHz</b>
Horizontal (dBi) peak	-2.91
Vertical (dBi) peak	-1.68

### 748MHz

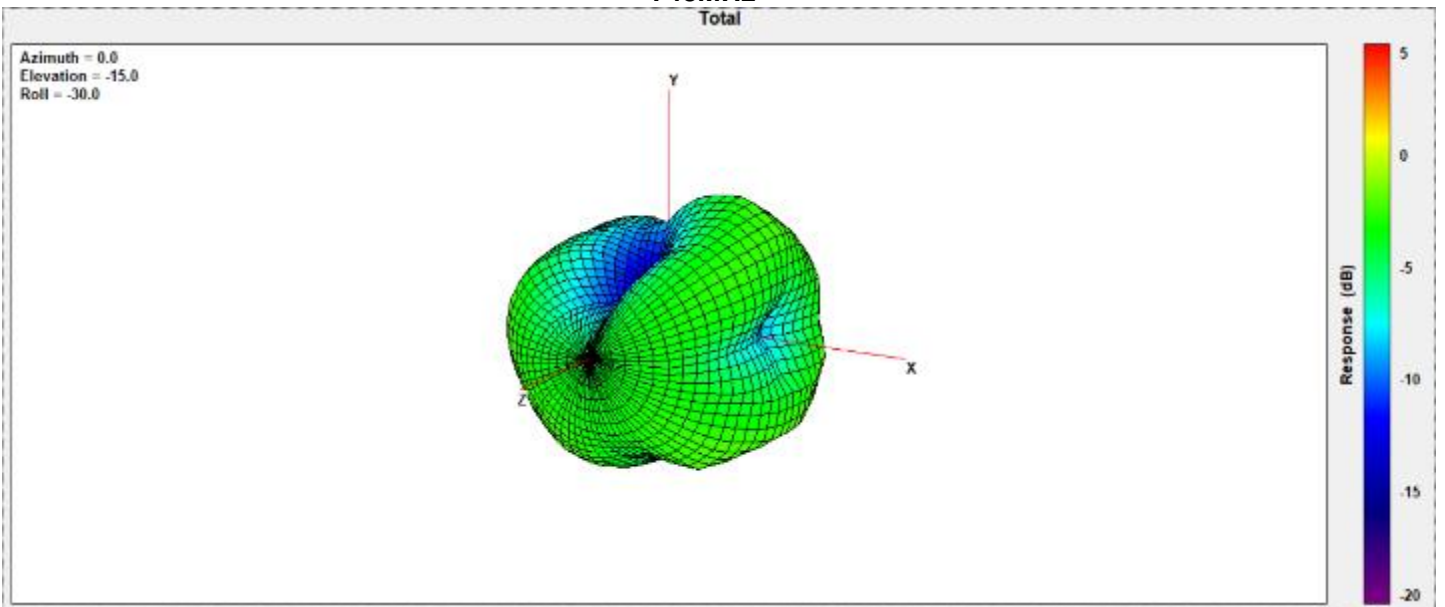

Center Frequency	<b>748MHz</b>
Horizontal (dBi) peak	-1.94
Vertical (dBi) peak	-1.94



### 756MHz

Total

Azimuth = 0.0  
Elevation = -15.0  
Roll = -30.0

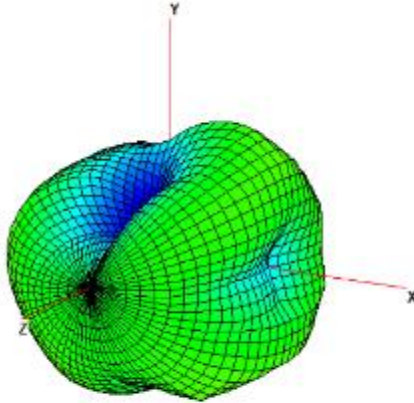

Center Frequency	<b>756MHz</b>
Horizontal (dBi) peak	-1.61
Vertical (dBi) peak	-1.90

### 768MHz

Total

Azimuth = 0.0  
Elevation = -15.0  
Roll = -30.0

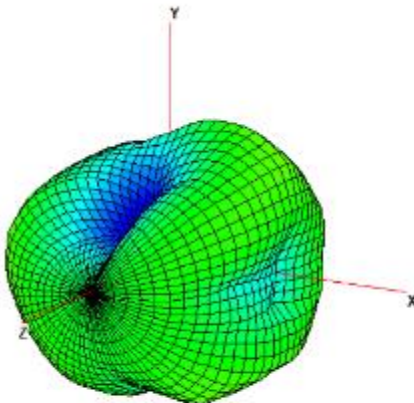

Center Frequency	<b>768MHz</b>
Horizontal (dBi) peak	-1.42
Vertical (dBi) peak	-1.77

**777MHz**

Total

Azimuth = 0.0  
Elevation = -15.0  
Roll = -30.0

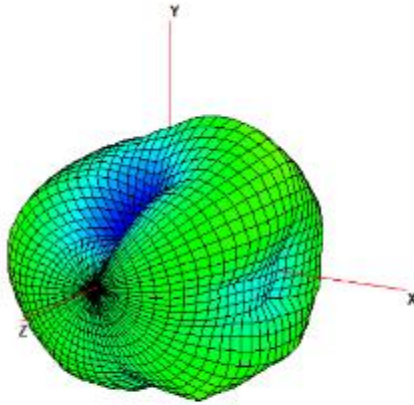

Center Frequency	<b>777MHz</b>
Horizontal (dBi) peak	-1.71
Vertical (dBi) peak	-1.80

**782MHz**

Total

Azimuth = 0.0  
Elevation = -15.0  
Roll = -30.0

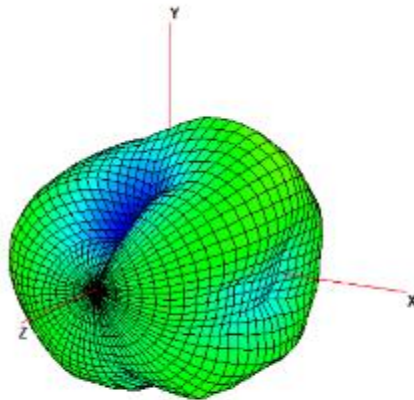

Center Frequency	<b>782MHz</b>
Horizontal (dBi) peak	-1.95
Vertical (dBi) peak	-1.77

### 787MHz

Total

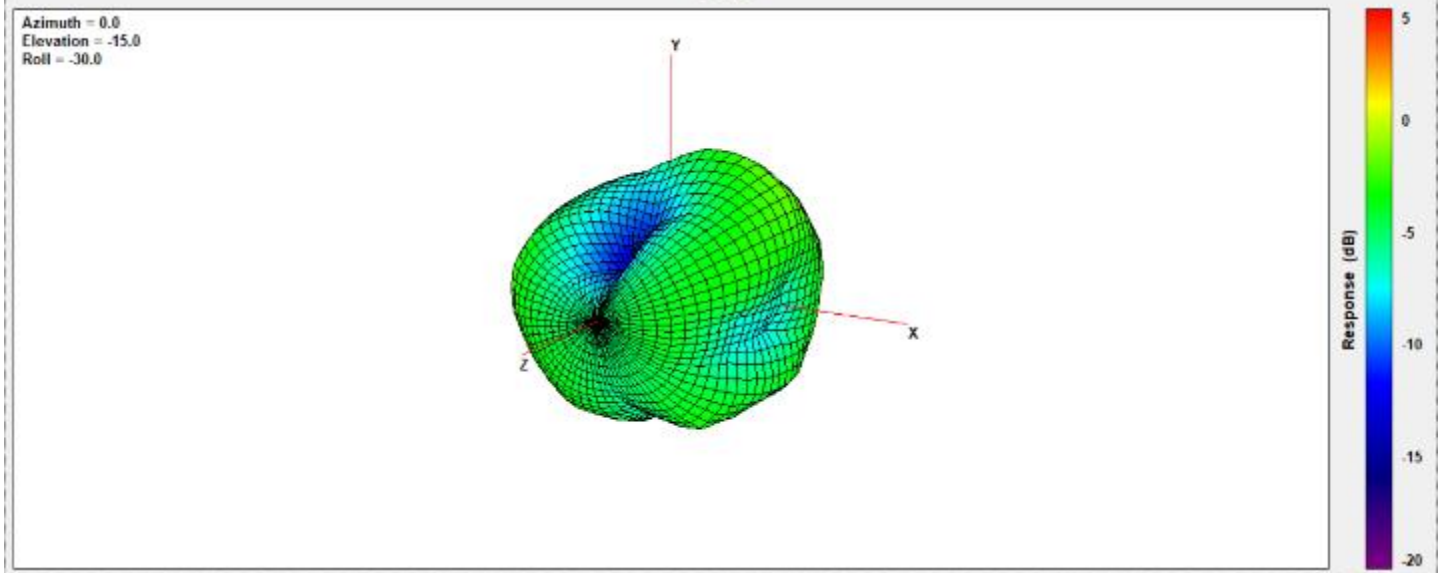

Center Frequency	<b>787MHz</b>
Horizontal (dBi) peak	-2.19
Vertical (dBi) peak	-1.78

### 814MHz

Total

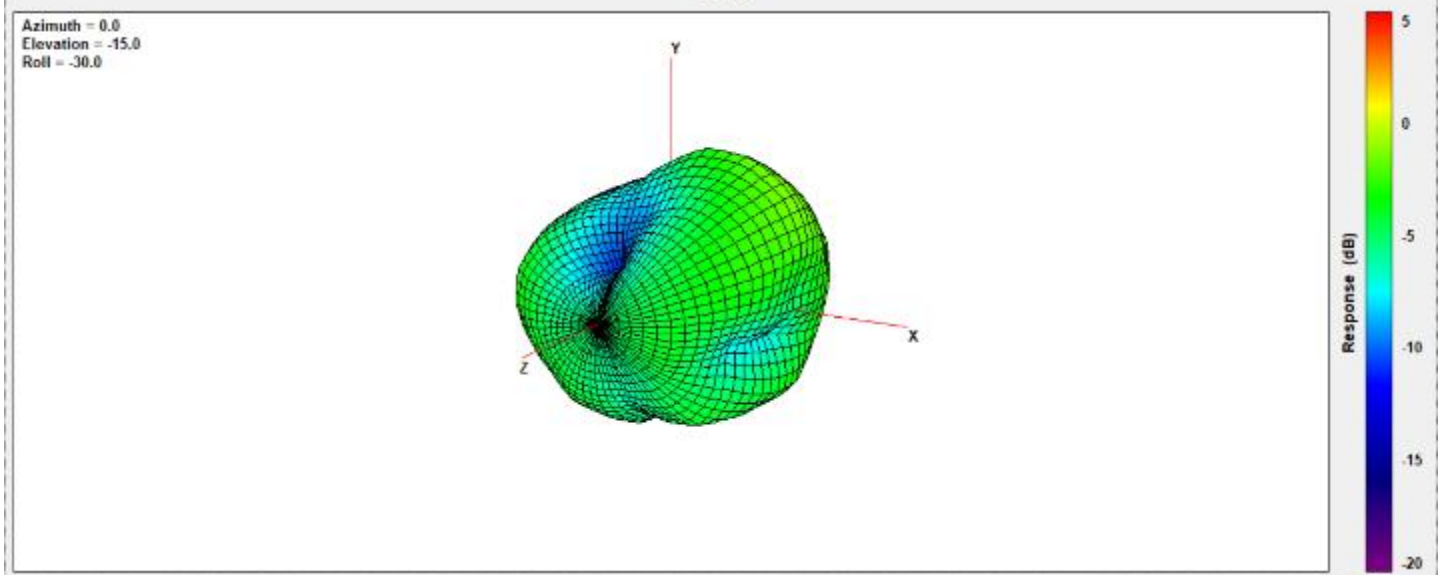

Center Frequency	<b>814MHz</b>
Horizontal (dBi) peak	-2.58
Vertical (dBi) peak	-1.29

### 824MHz

Total

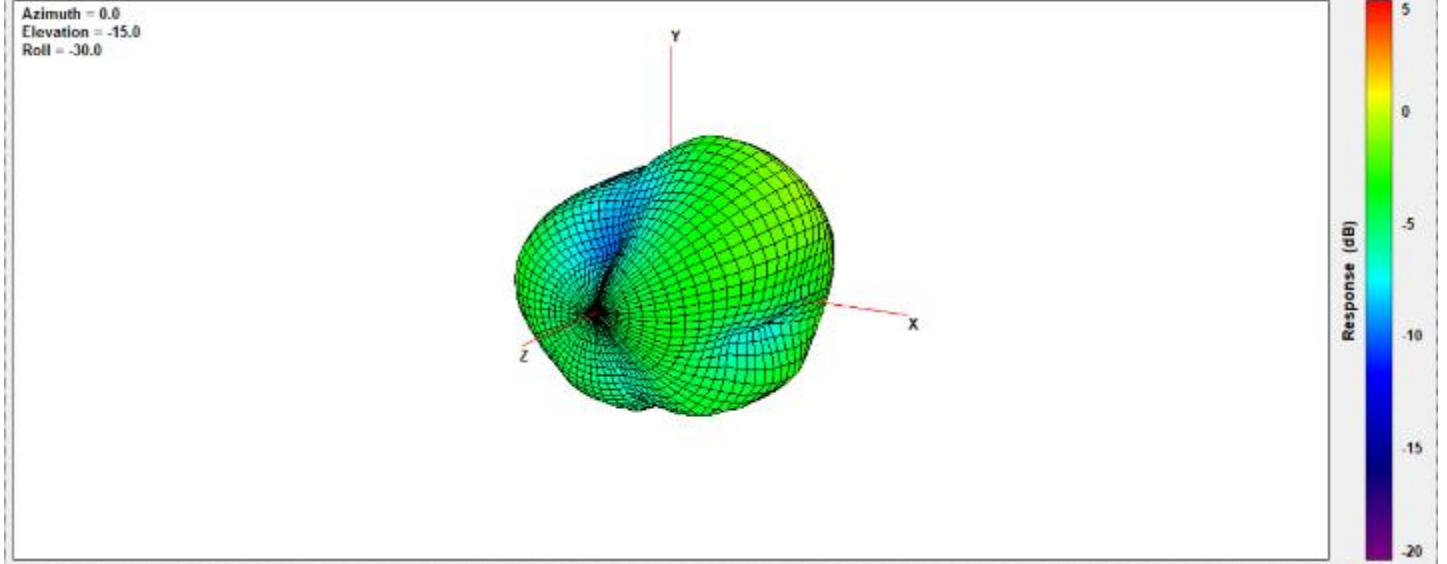

Center Frequency	<b>824MHz</b>
Horizontal (dBi) peak	-2.19
Vertical (dBi) peak	-0.96

### 832MHz

Total

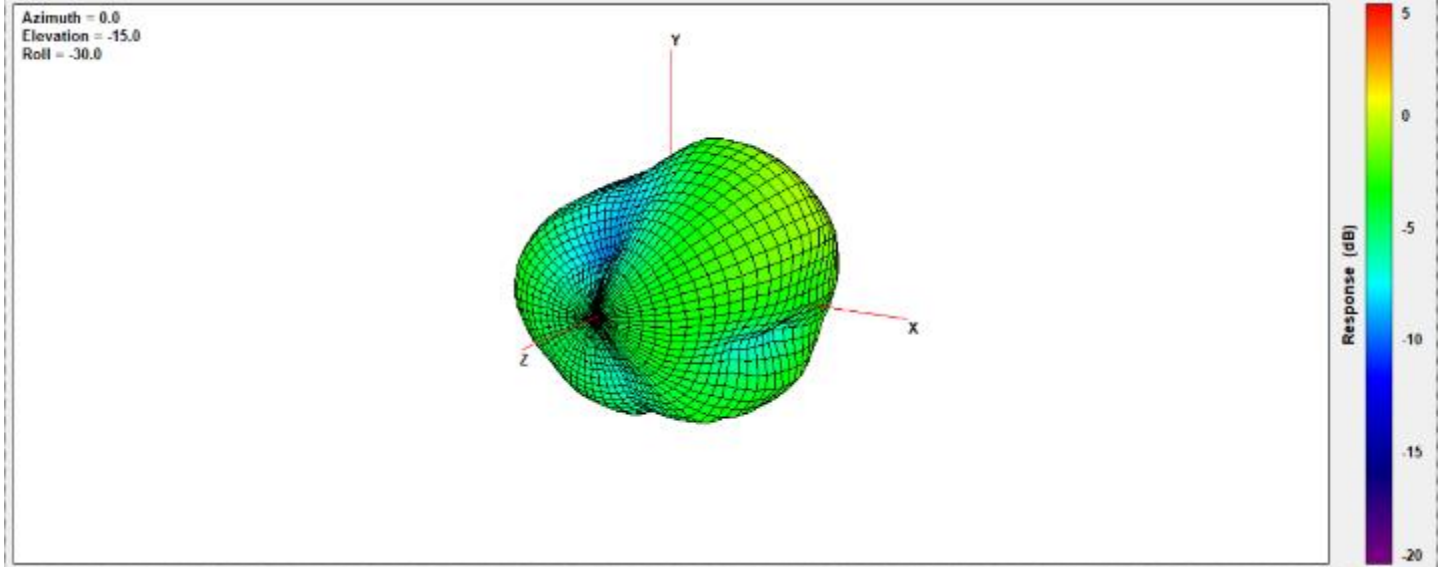

Center Frequency	<b>832MHz</b>
Horizontal (dBi) peak	-1.93
Vertical (dBi) peak	-0.62

### 836.5MHz

Total

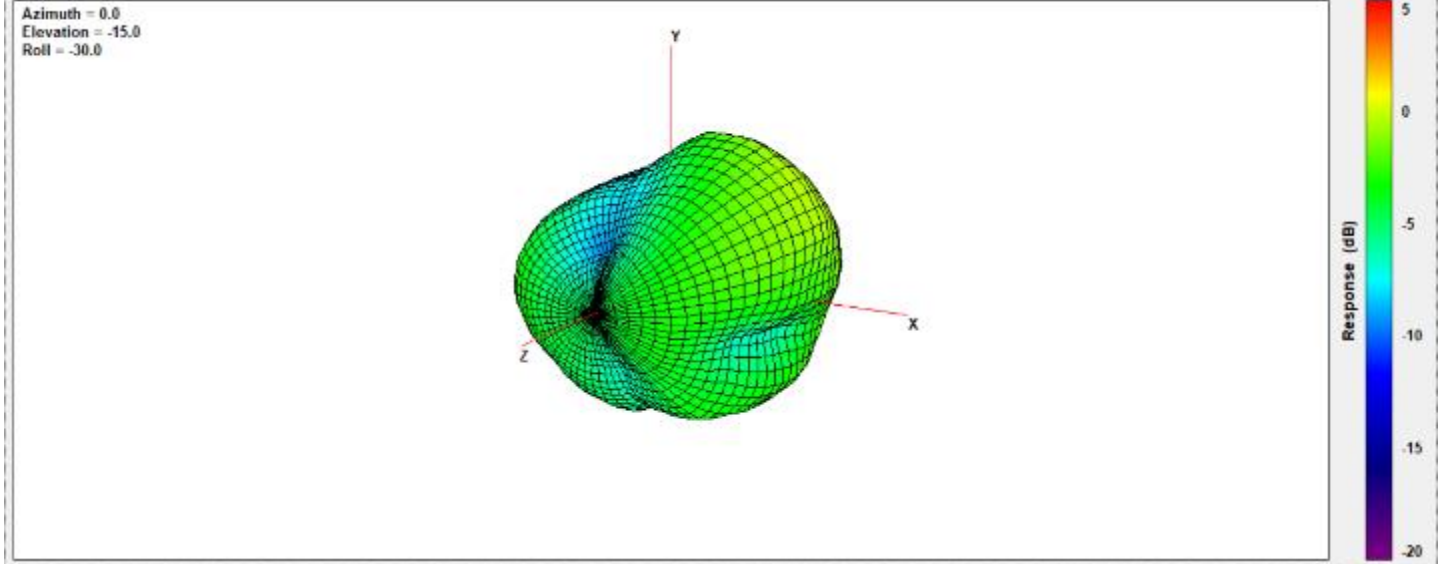

Center Frequency	<b>836.5MHz</b>
Horizontal (dBi) peak	-1.74
Vertical (dBi) peak	-0.39

### 849MHz

Total

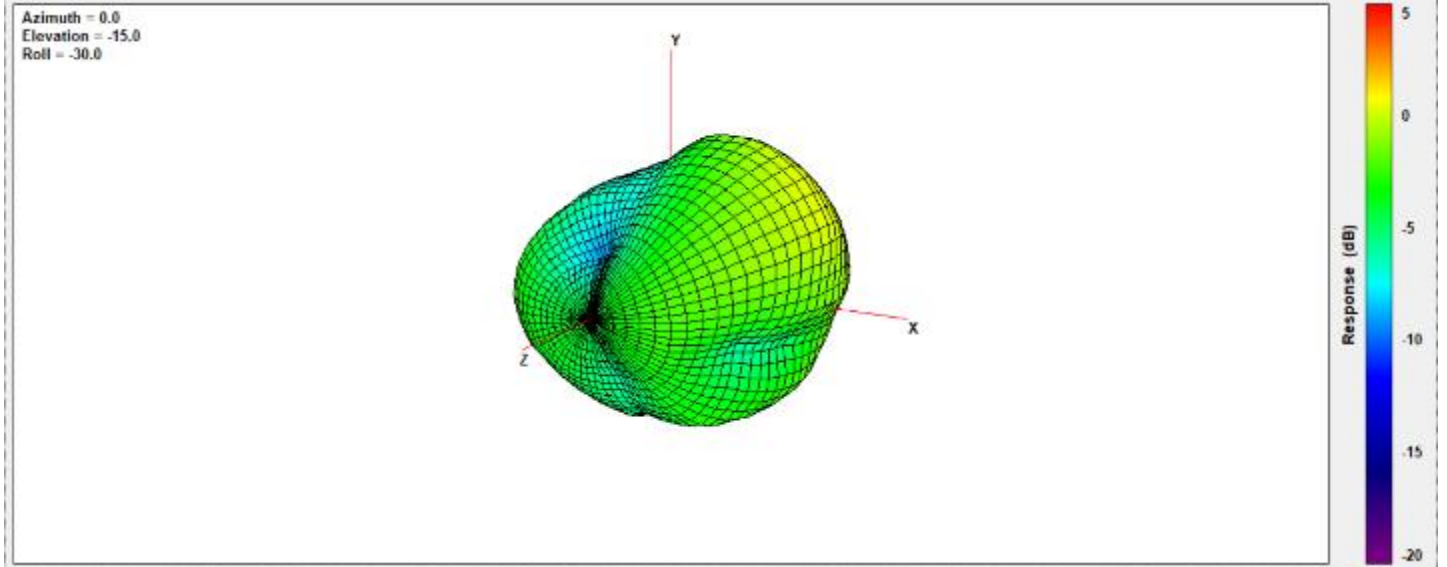

Center Frequency	<b>849MHz</b>
Horizontal (dBi) peak	-1.08
Vertical (dBi) peak	0.36

### 862MHz

Total

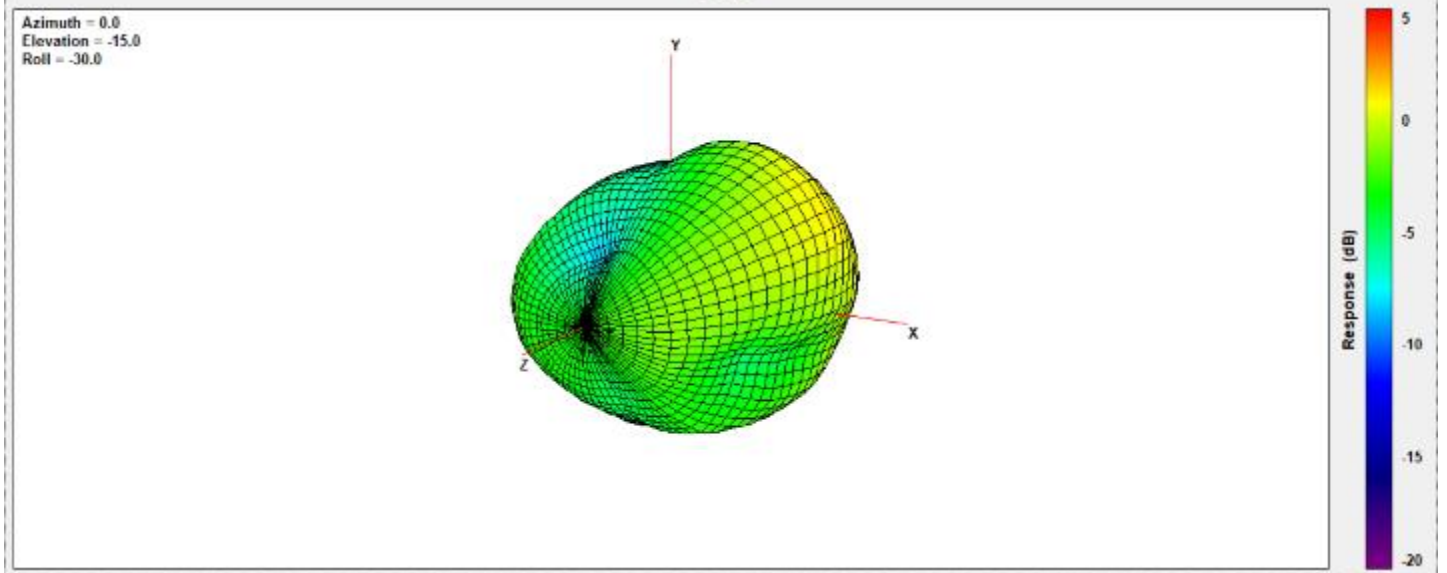

Center Frequency	<b>862MHz</b>
Horizontal (dBi) peak	-0.18
Vertical (dBi) peak	0.96

### 880MHz

Total

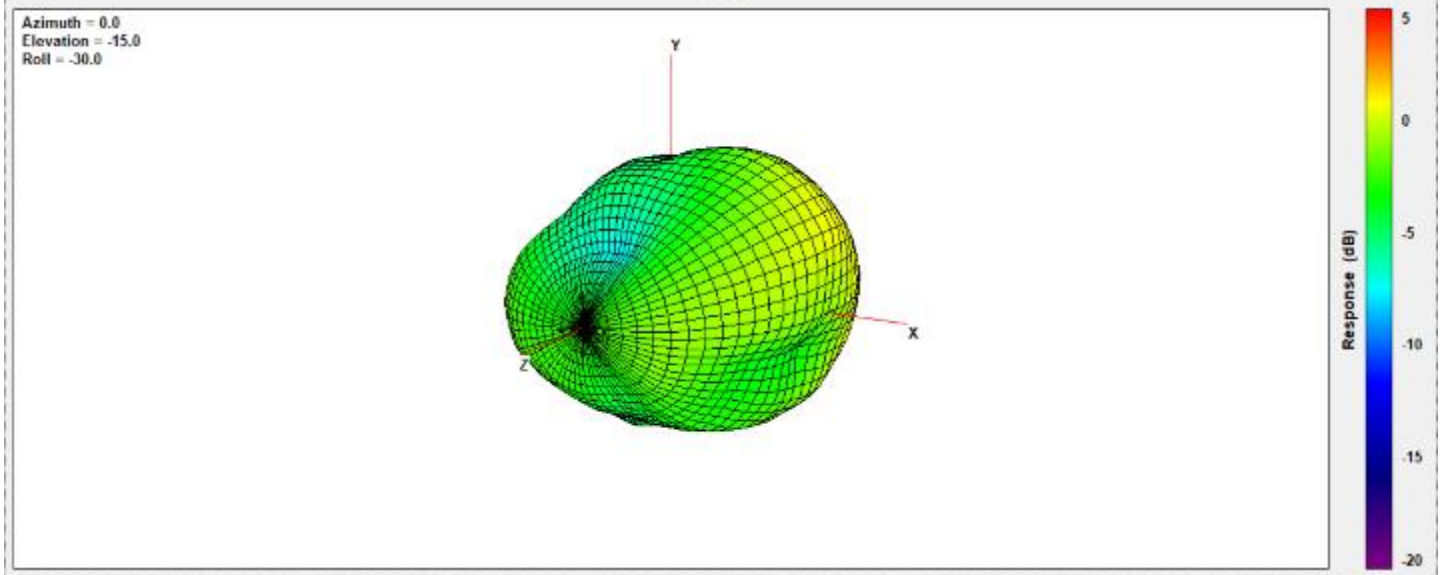

Center Frequency	<b>880MHz</b>
Horizontal (dBi) peak	0.20
Vertical (dBi) peak	0.61

**897.5MHz**

Total

Azimuth = 0.0  
Elevation = -15.0  
Roll = -30.0

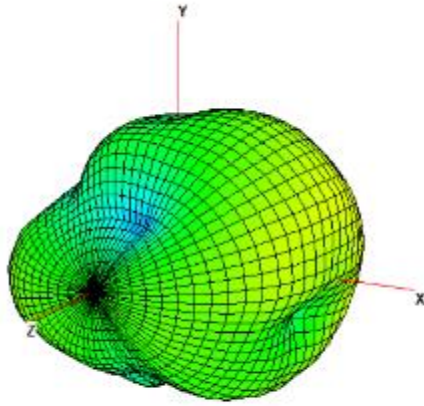

Center Frequency	<b>897.5MHz</b>
Horizontal (dBi) peak	0.10
Vertical (dBi) peak	0.32

**915MHz**

Total

Azimuth = 0.0  
Elevation = -15.0  
Roll = -30.0

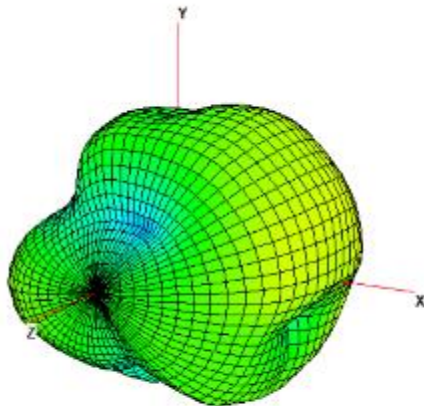

Center Frequency	<b>915MHz</b>
Horizontal (dBi) peak	-0.30
Vertical (dBi) peak	0.21

**925MHz**

Total

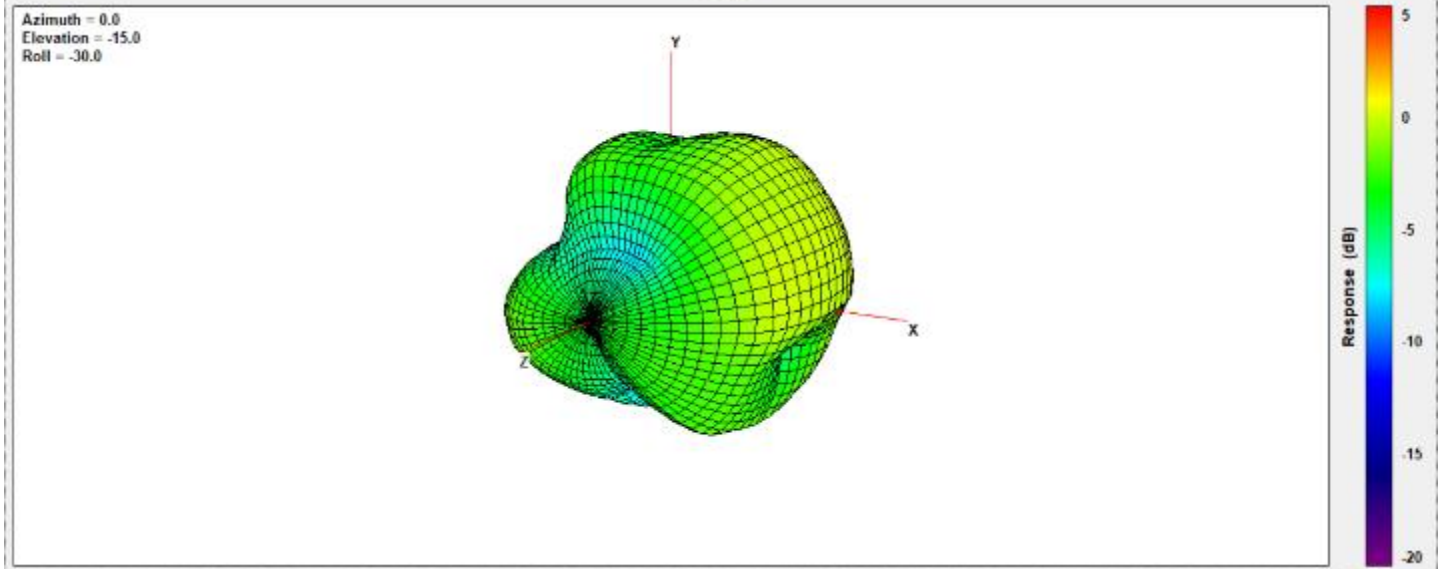

Center Frequency	<b>925MHz</b>
Horizontal (dBi) peak	-0.64
Vertical (dBi) peak	-0.01

**960MHz**

Total

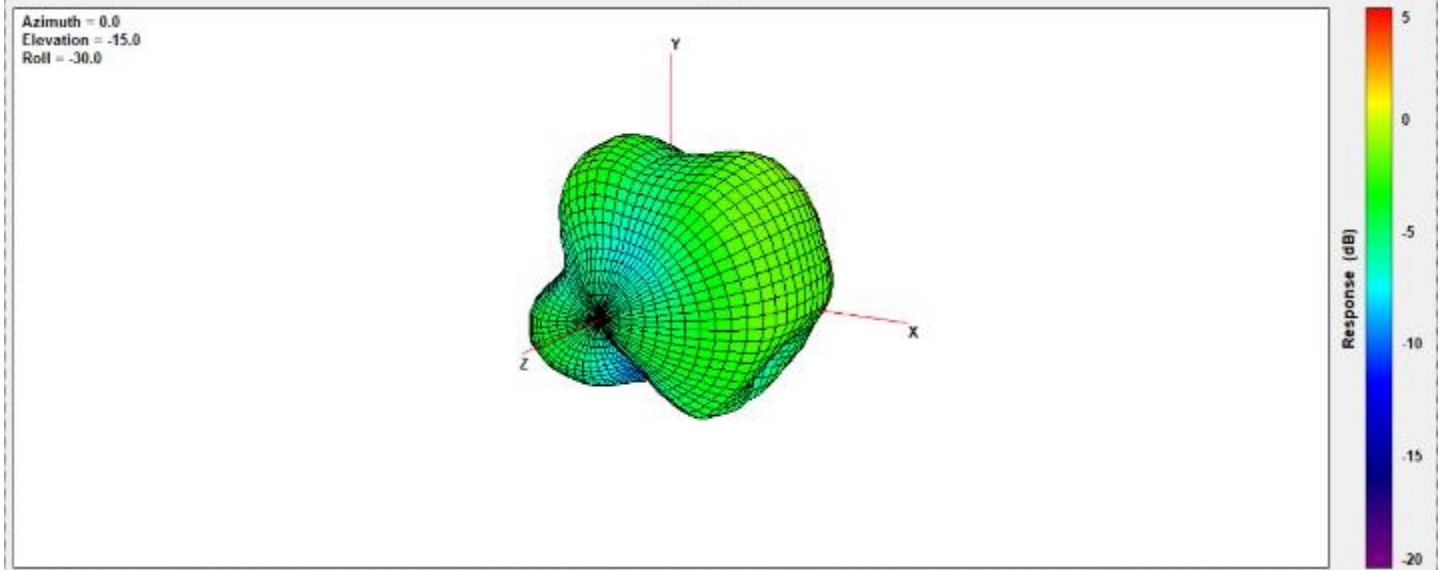

Center Frequency	<b>960MHz</b>
Horizontal (dBi) peak	-3.90
Vertical (dBi) peak	-1.46



**1427.9MHz**

Total

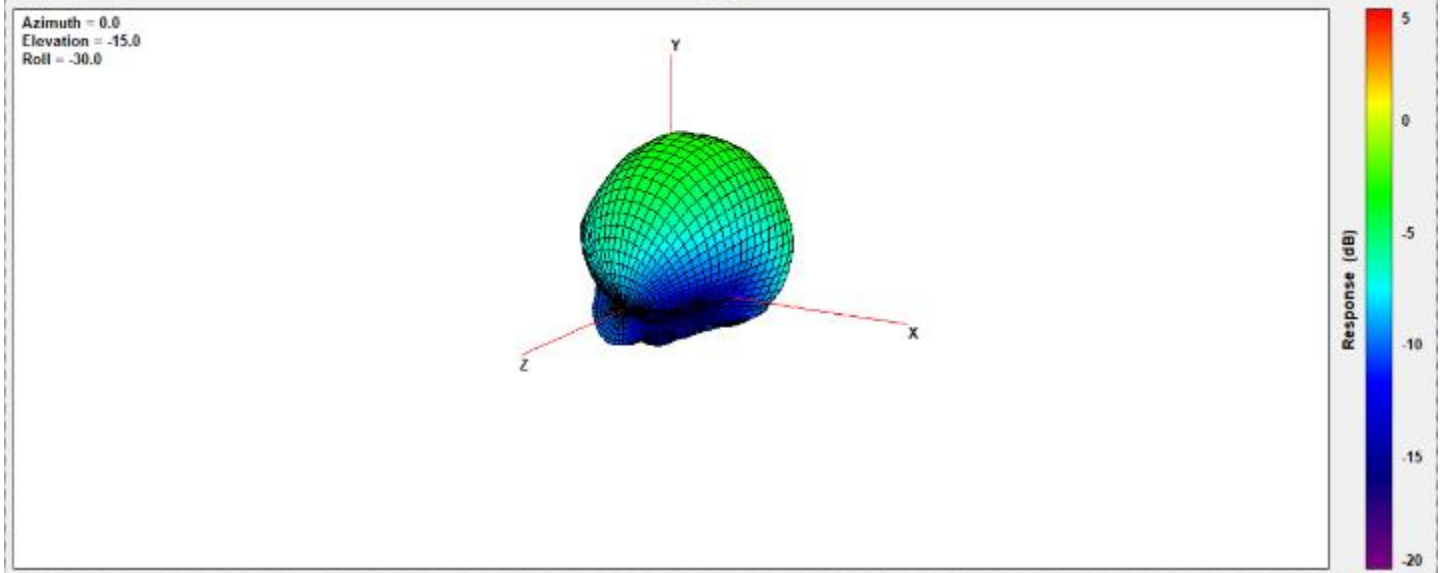

Center Frequency	<b>1427.9MHz</b>
Horizontal (dBi) peak	-6.18
Vertical (dBi) peak	-2.72

**1447.9MHz**

Total

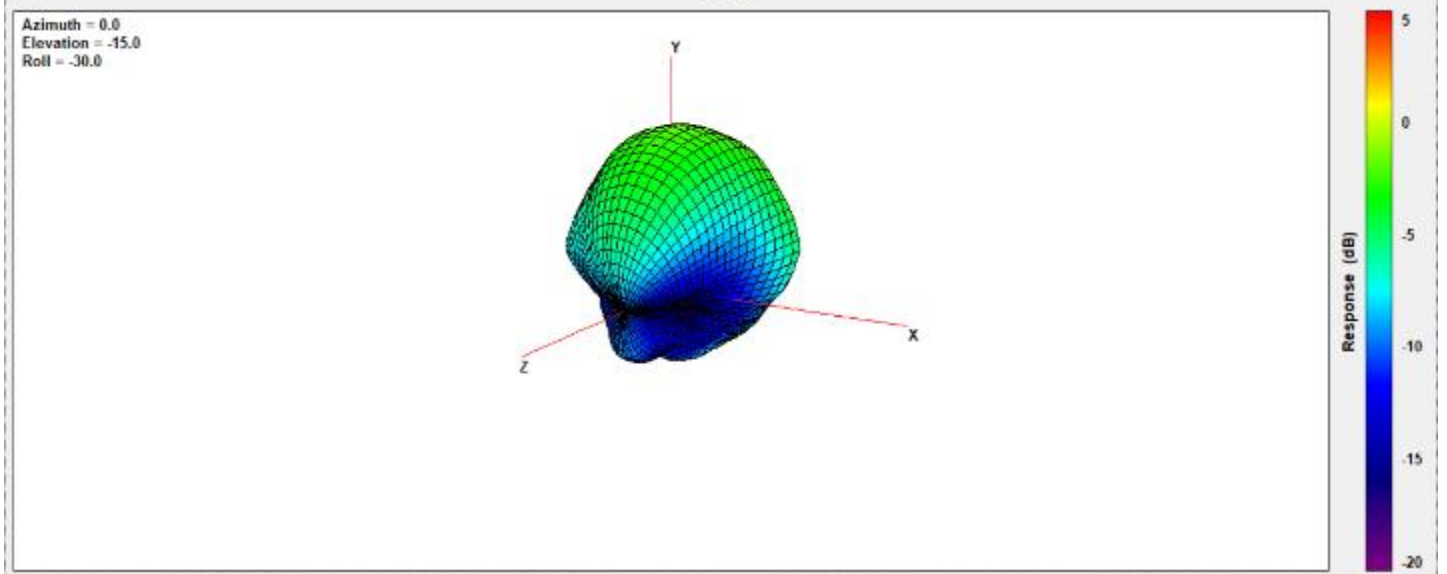

Center Frequency	<b>1447.9MHz</b>
Horizontal (dBi) peak	-3.76
Vertical (dBi) peak	-1.63

**1455.4MHz**

Total

Azimuth = 0.0  
Elevation = -15.0  
Roll = -30.0

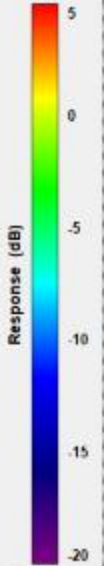
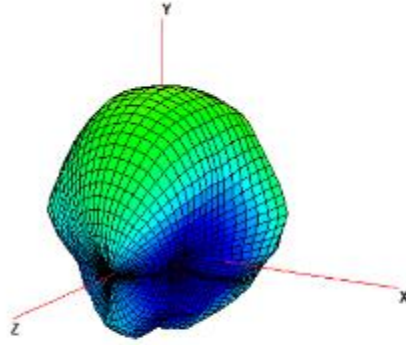

Center Frequency	<b>1455.4MHz</b>
Horizontal (dBi) peak	-2.97
Vertical (dBi) peak	-1.19

**1462.9MHz**

Total

Azimuth = 0.0  
Elevation = -15.0  
Roll = -30.0

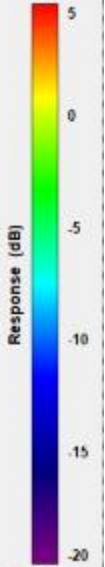
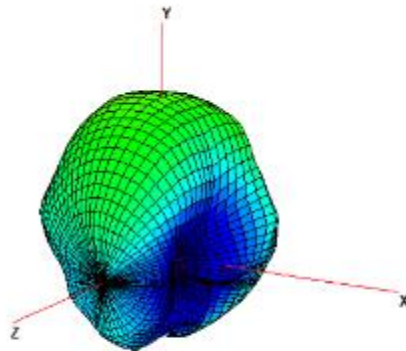

Center Frequency	<b>1462.9MHz</b>
Horizontal (dBi) peak	-2.52
Vertical (dBi) peak	-0.84

**1496MHz**

Total

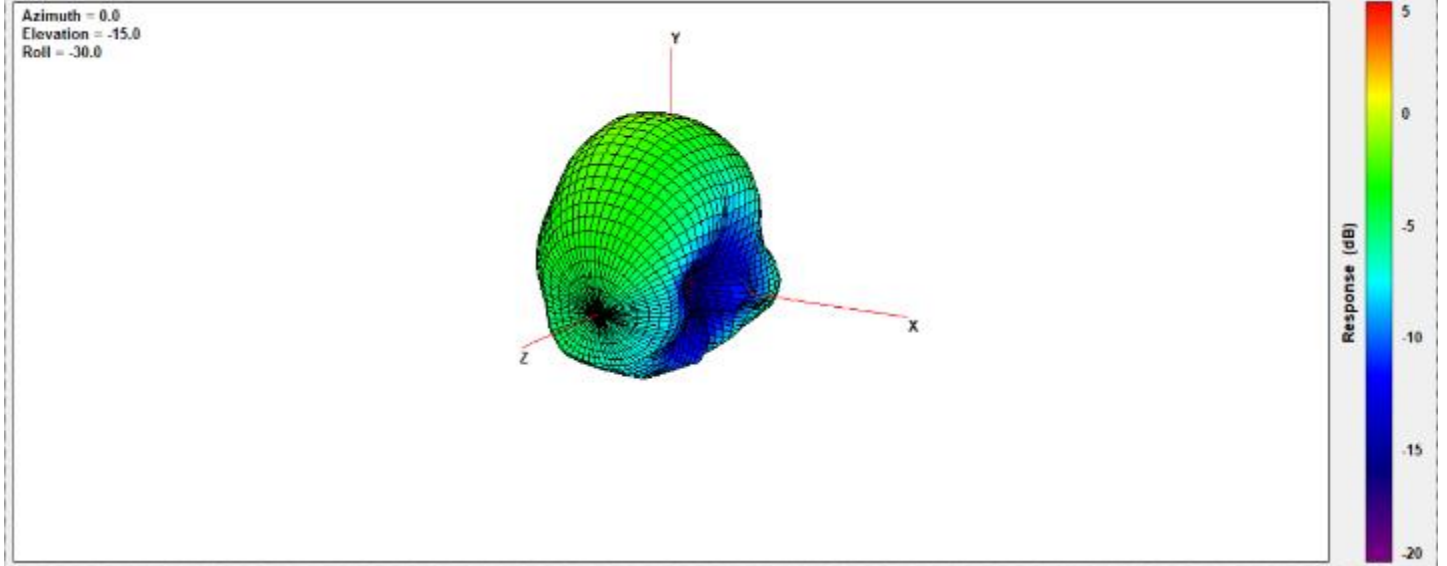

Center Frequency	<b>1496MHz</b>
Horizontal (dBi) peak	-2.67
Vertical (dBi) peak	-0.48

**1510.9 MHz**

Total

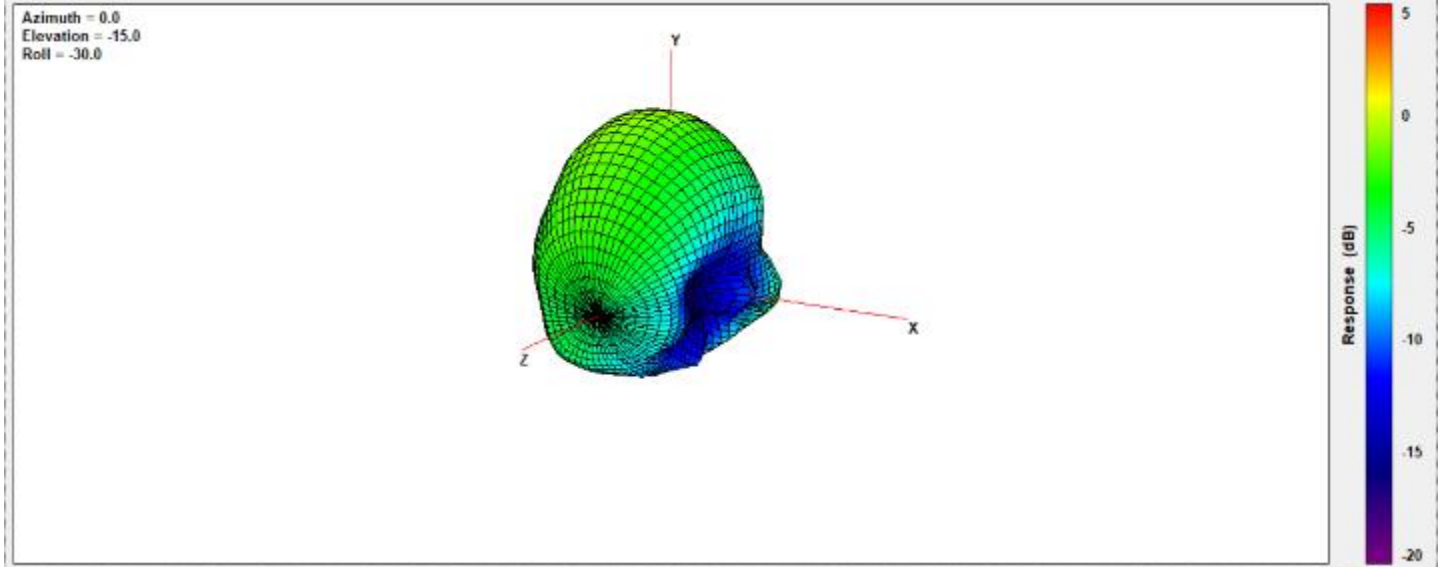

Center Frequency	<b>1510.9 MHz</b>
Horizontal (dBi) peak	-2.77
Vertical (dBi) peak	-0.32

### 1710 MHz

Total

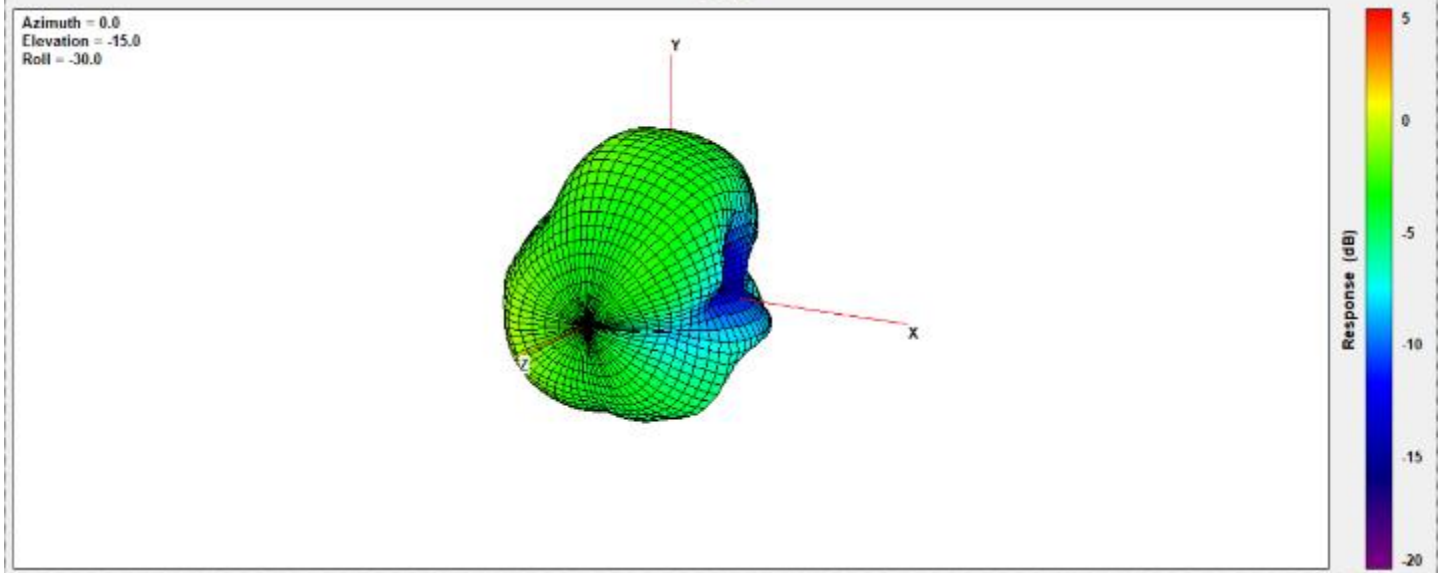

Center Frequency	<b>1710 MHz</b>
Horizontal (dBi) peak	-0.82
Vertical (dBi) peak	-0.72

### 1732.5 MHz

Total

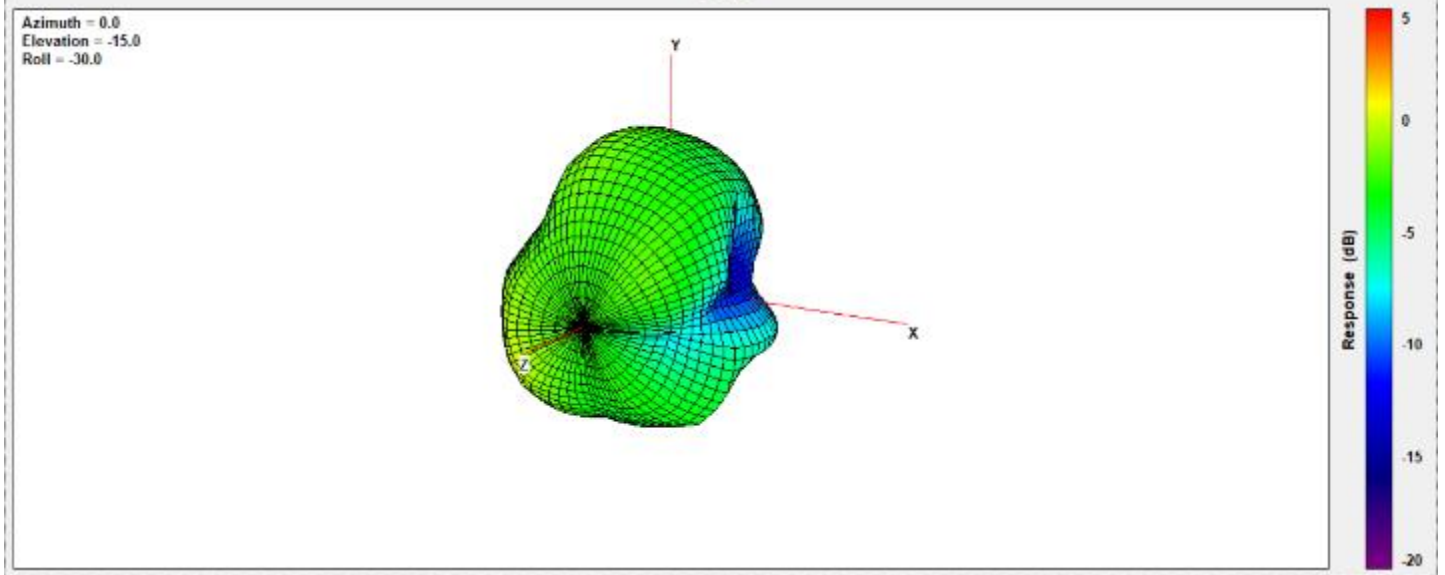

Center Frequency	<b>1732.5 MHz</b>
Horizontal (dBi) peak	-0.12
Vertical (dBi) peak	-0.61

**1747.5 MHz**

Total

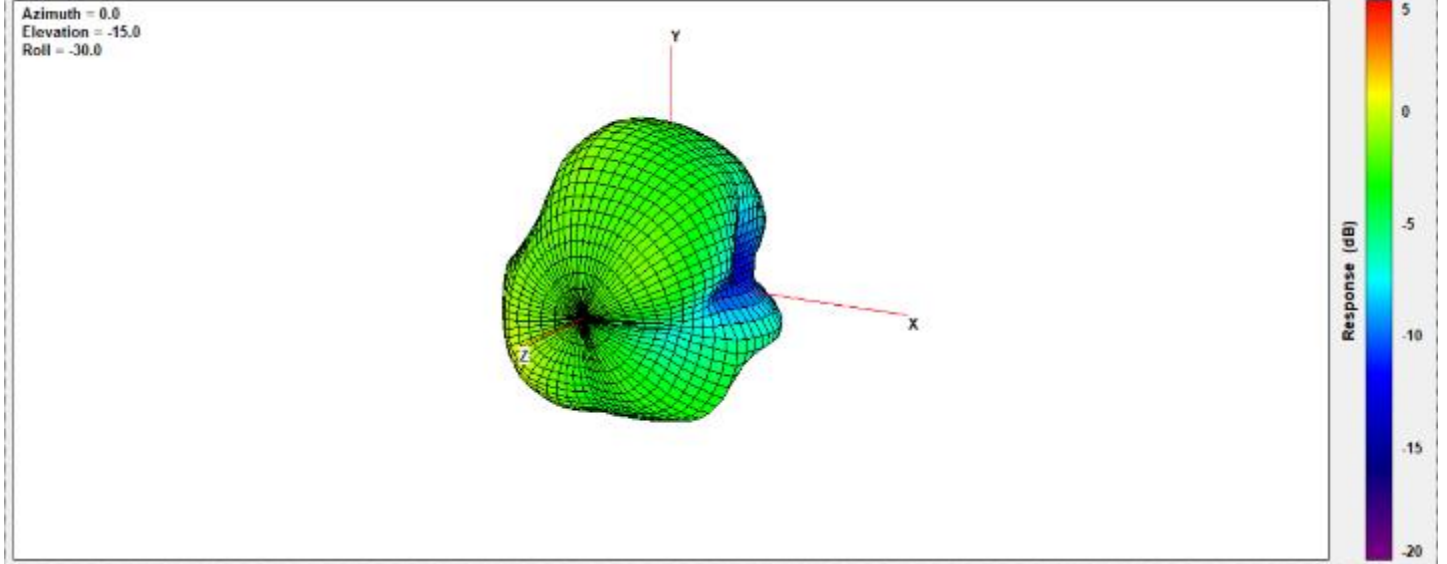

Center Frequency	<b>1747.5 MHz</b>
Horizontal (dBi) peak	0.06
Vertical (dBi) peak	-0.82

**1755 MHz**

Total

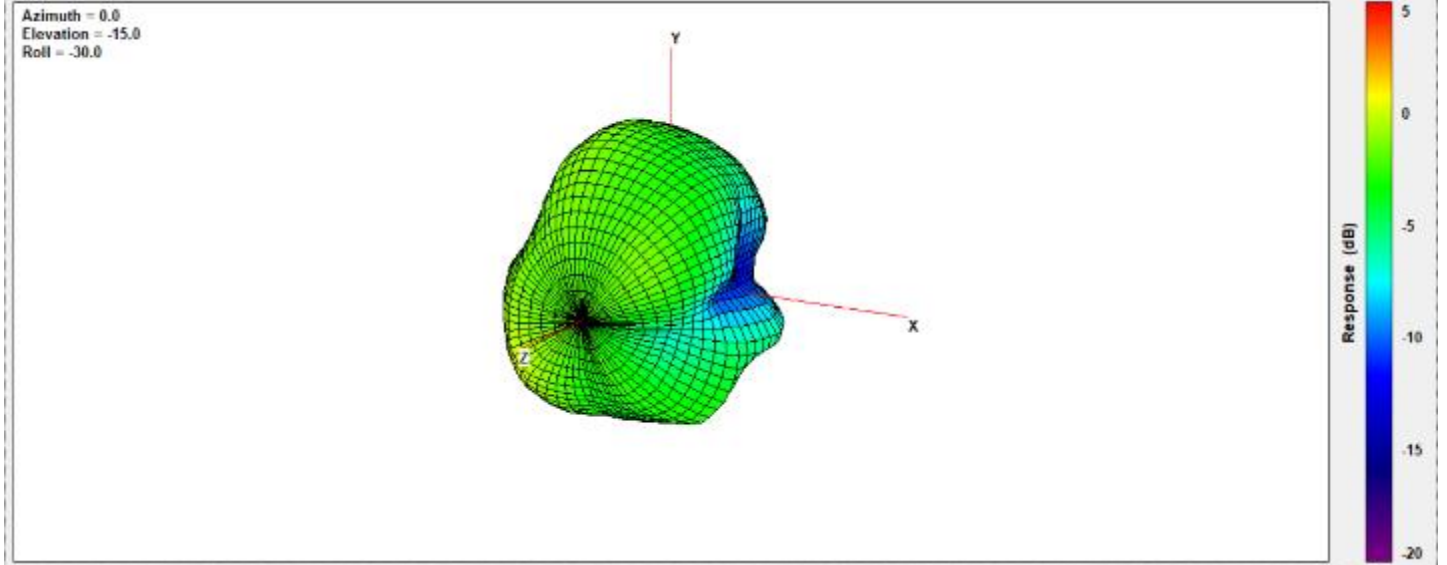

Center Frequency	<b>1755 MHz</b>
Horizontal (dBi) peak	0.06
Vertical (dBi) peak	-1.00

**1785 MHz**

Total

Azimuth = 0.0  
Elevation = -15.0  
Roll = -30.0

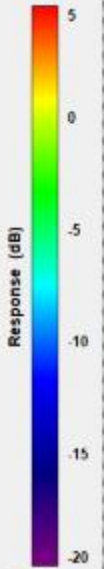
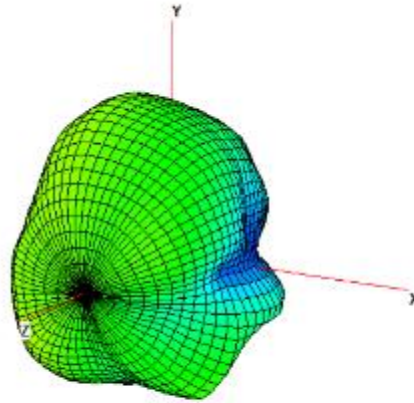

Center Frequency	<b>1785 MHz</b>
Horizontal (dBi) peak	-0.72
Vertical (dBi) peak	-0.96

**1805 MHz**

Total

Azimuth = 0.0  
Elevation = -15.0  
Roll = -30.0

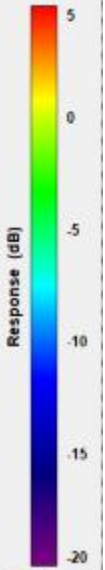
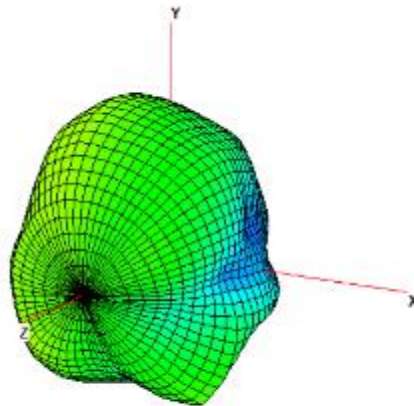

Center Frequency	<b>1805 MHz</b>
Horizontal (dBi) peak	-0.96
Vertical (dBi) peak	-0.79

**1850 MHz**

Total

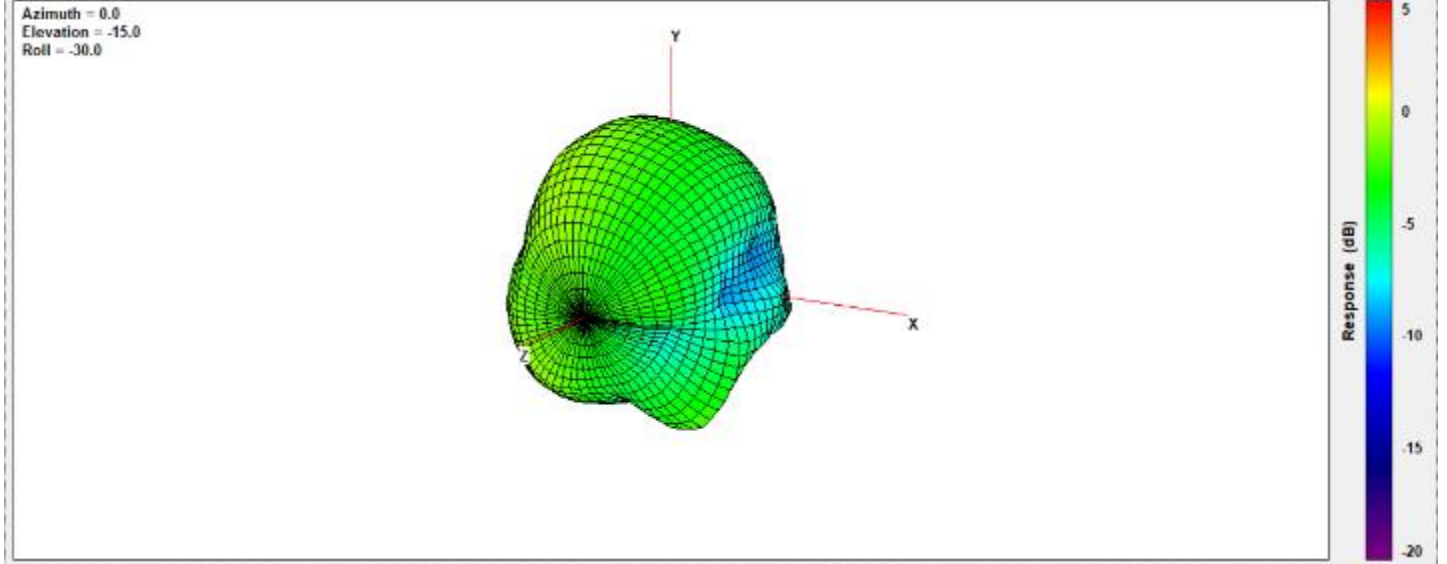

Center Frequency	<b>1850 MHz</b>
Horizontal (dBi) peak	-1.58
Vertical (dBi) peak	-0.92

**1880 MHz**

Total

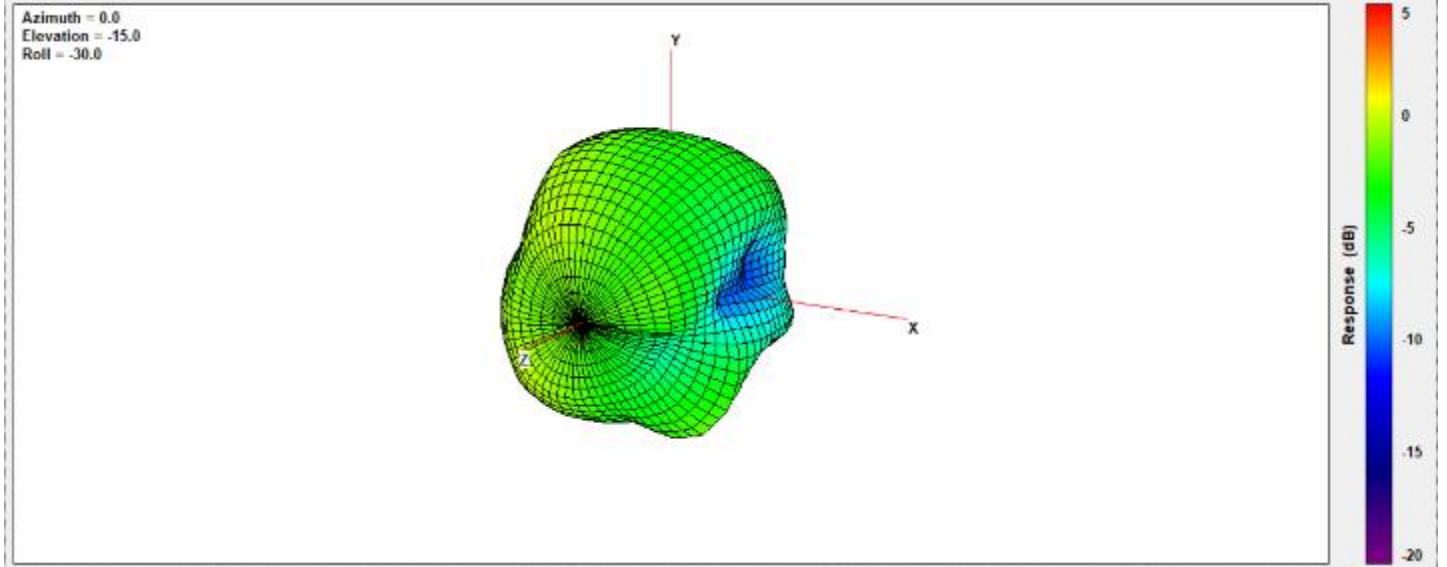

Center Frequency	<b>1880 MHz</b>
Horizontal (dBi) peak	-0.71
Vertical (dBi) peak	-0.57

### 1910MHz

Total

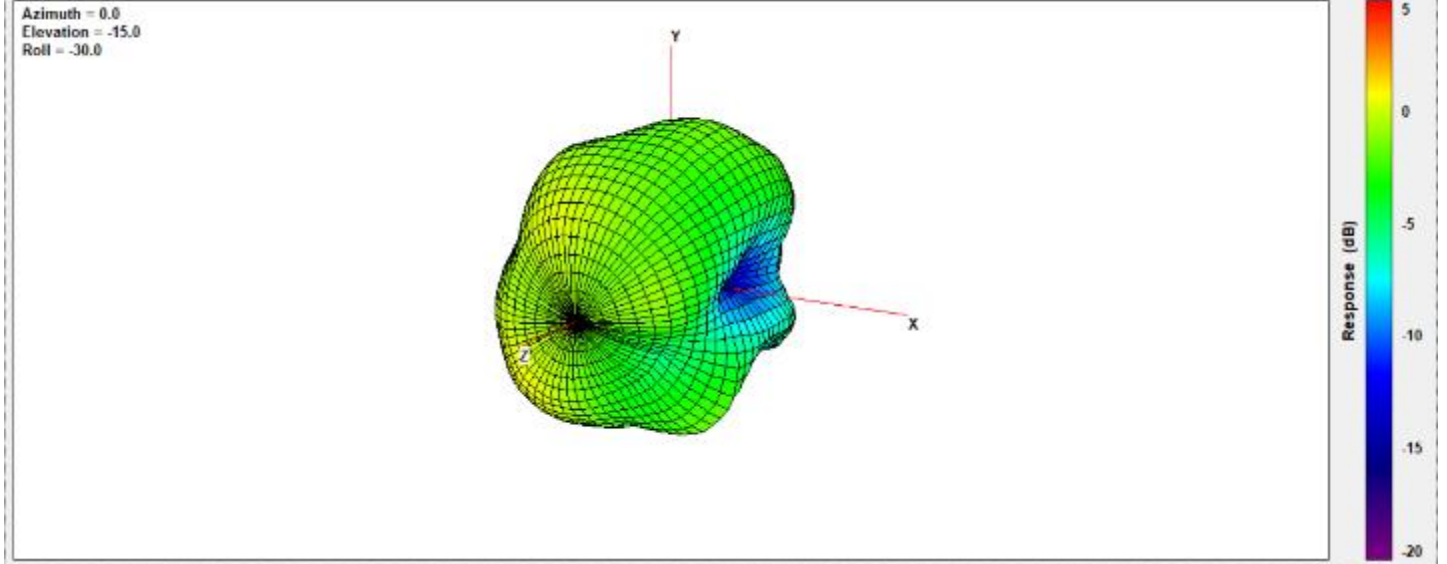

Center Frequency	<b>1910MHz</b>
Horizontal (dBi) peak	0.22
Vertical (dBi) peak	0.13

### 1920MHz

Total

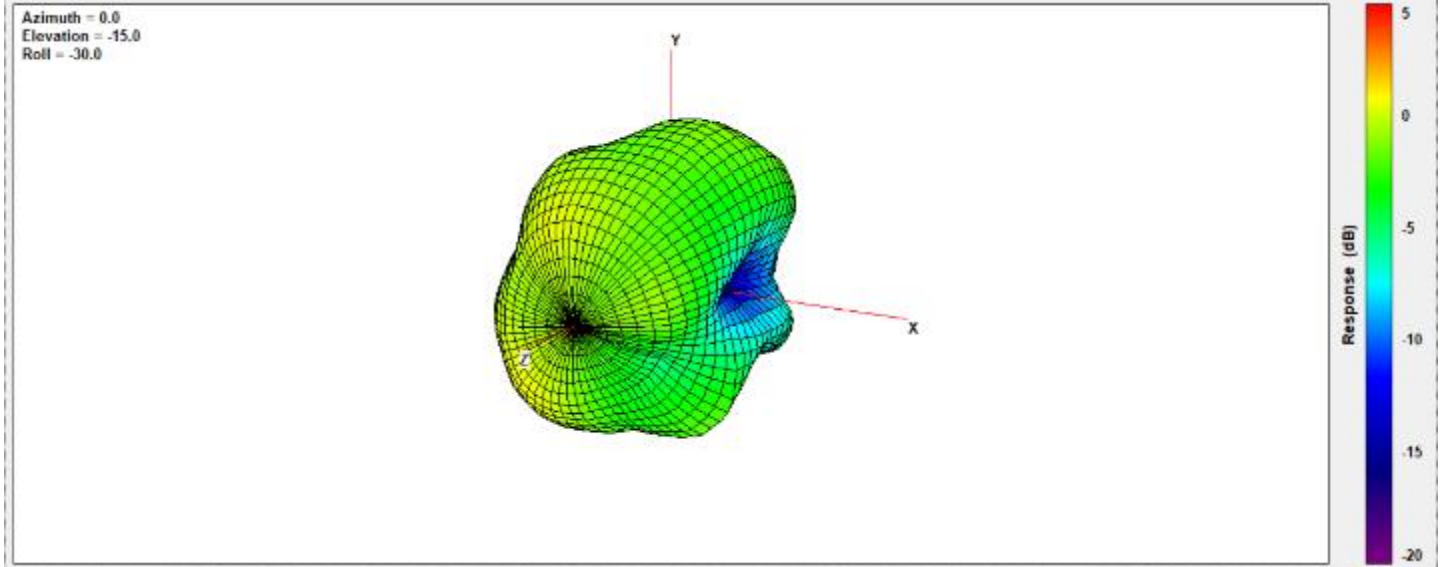

Center Frequency	<b>1920MHz</b>
Horizontal (dBi) peak	0.37
Vertical (dBi) peak	0.21



### 1950MHz

Total

Azimuth = 0.0  
Elevation = -15.0  
Roll = -30.0

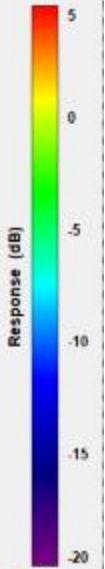
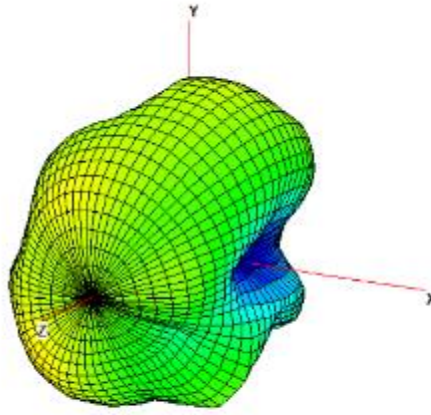

Center Frequency	<b>1950MHz</b>
Horizontal (dBi) peak	0.83
Vertical (dBi) peak	0.59

### 1980MHz

Total

Azimuth = 0.0  
Elevation = -15.0  
Roll = -30.0

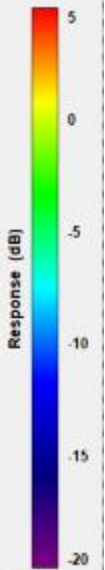
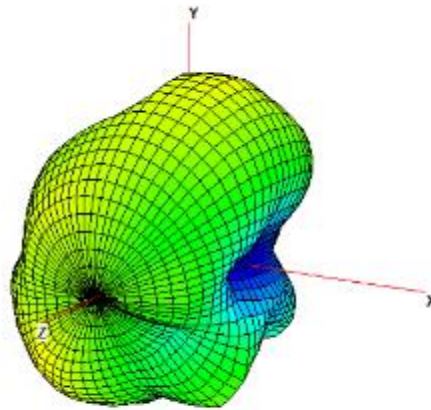

Center Frequency	<b>1980MHz</b>
Horizontal (dBi) peak	0.53
Vertical (dBi) peak	0.34

### 2110MHz

Total

Azimuth = 0.0  
Elevation = -15.0  
Roll = -30.0

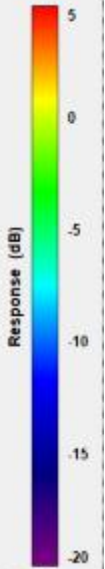
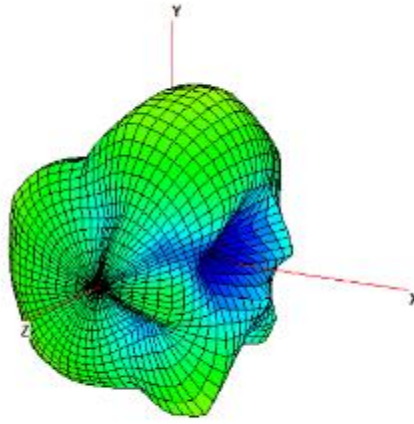

Center Frequency	<b>2110MHz</b>
Horizontal (dBi) peak	-0.80
Vertical (dBi) peak	-1.07

### 2200MHz

Total

Azimuth = 0.0  
Elevation = -15.0  
Roll = -30.0

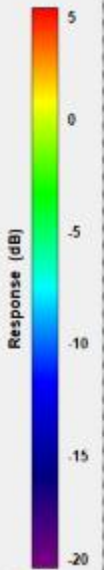
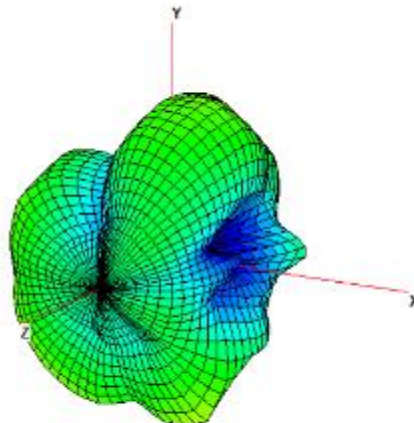

Center Frequency	<b>2200MHz</b>
Horizontal (dBi) peak	-0.49
Vertical (dBi) peak	-1.54

### 2300MHz

Total

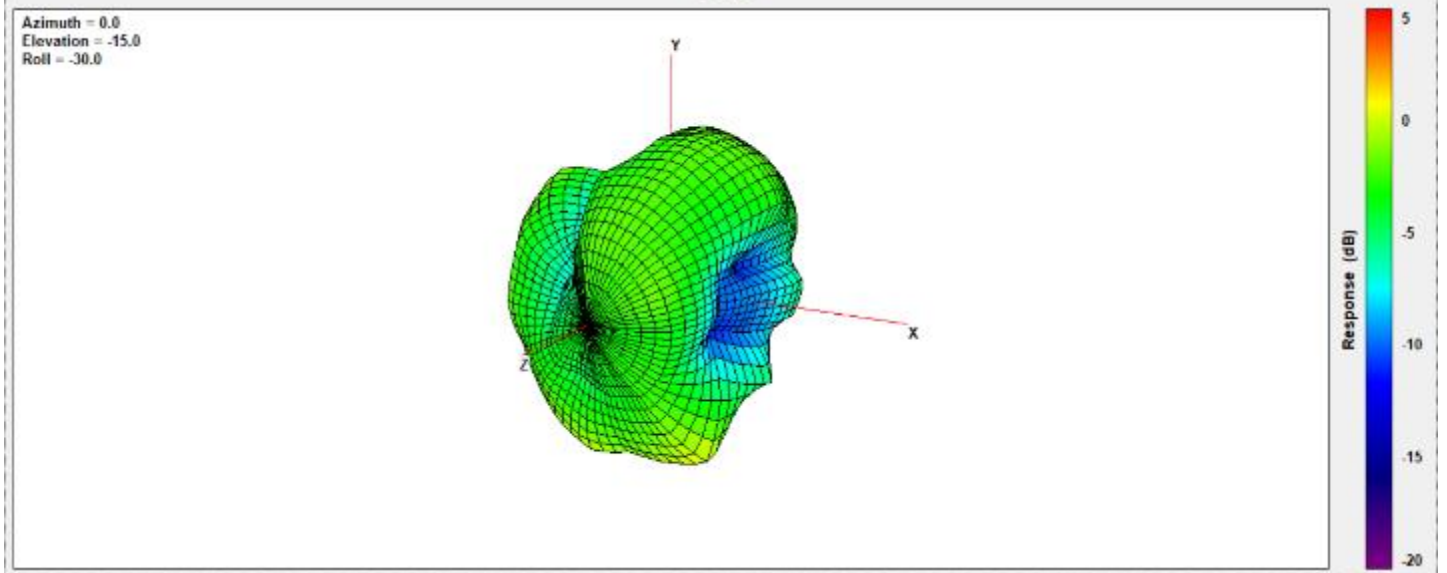

Center Frequency	<b>2300MHz</b>
Horizontal (dBi) peak	0.46
Vertical (dBi) peak	-0.69

### 2305MHz

Total

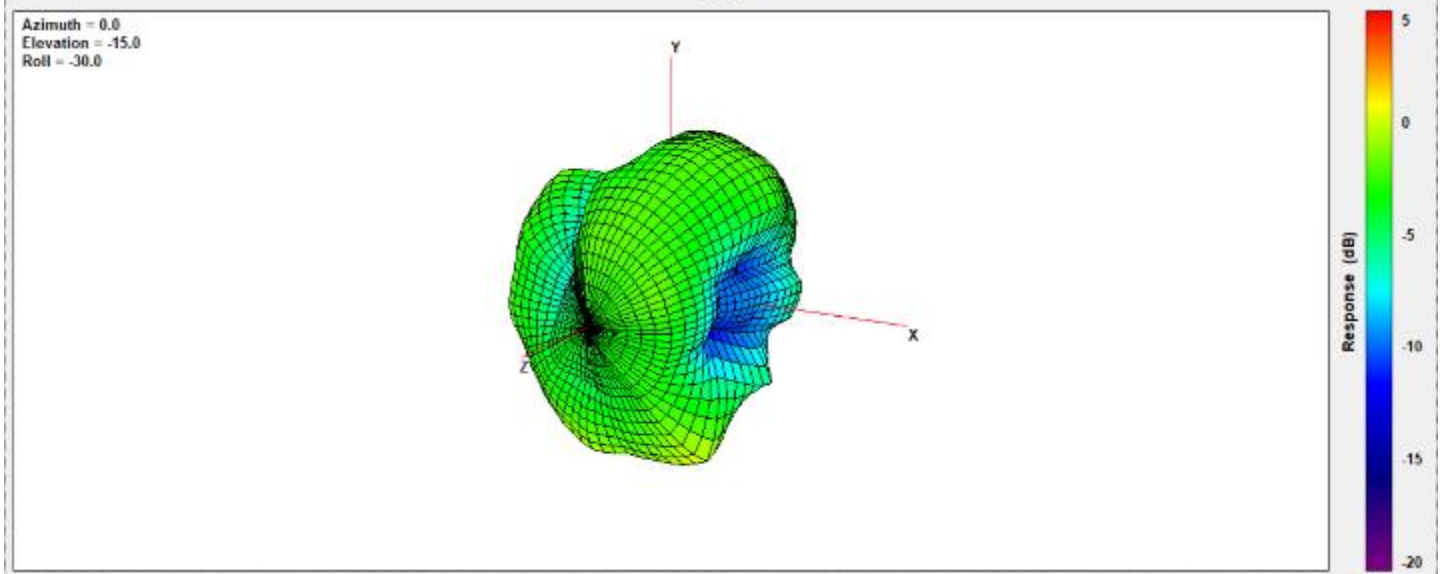

Center Frequency	<b>2305MHz</b>
Horizontal (dBi) peak	0.25
Vertical (dBi) peak	-0.77

### 2315MHz

Total

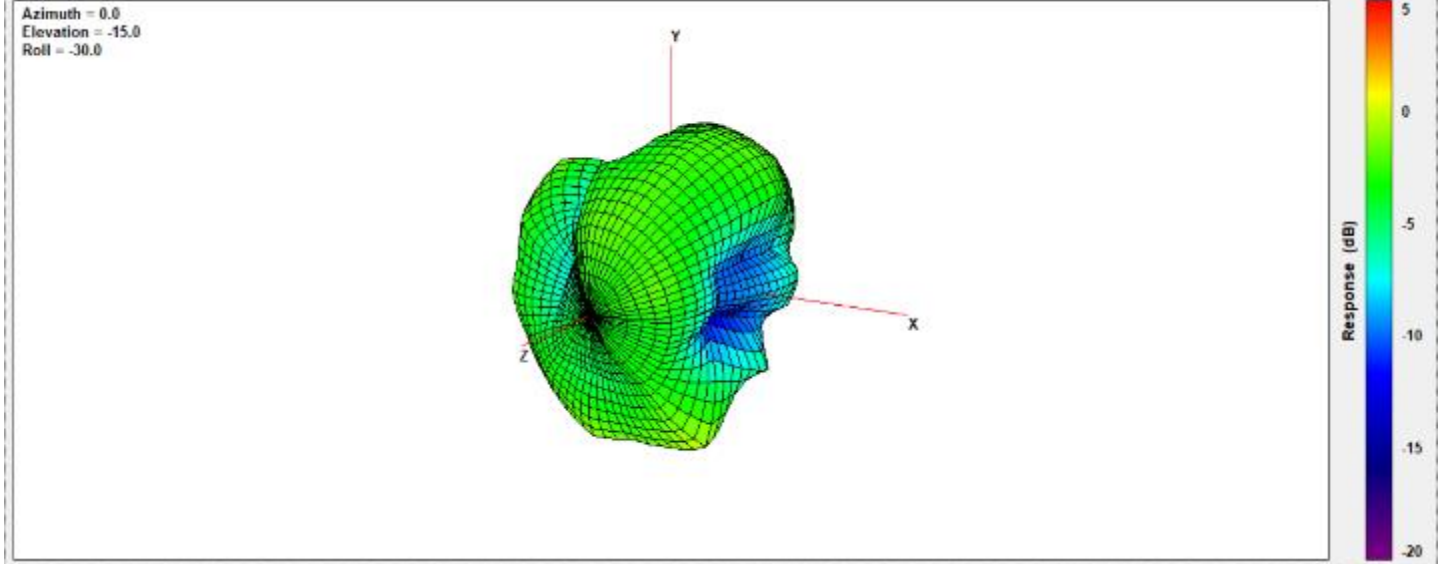

Center Frequency	<b>2315MHz</b>
Horizontal (dBi) peak	-0.20
Vertical (dBi) peak	-0.73

### 2350MHz

Total

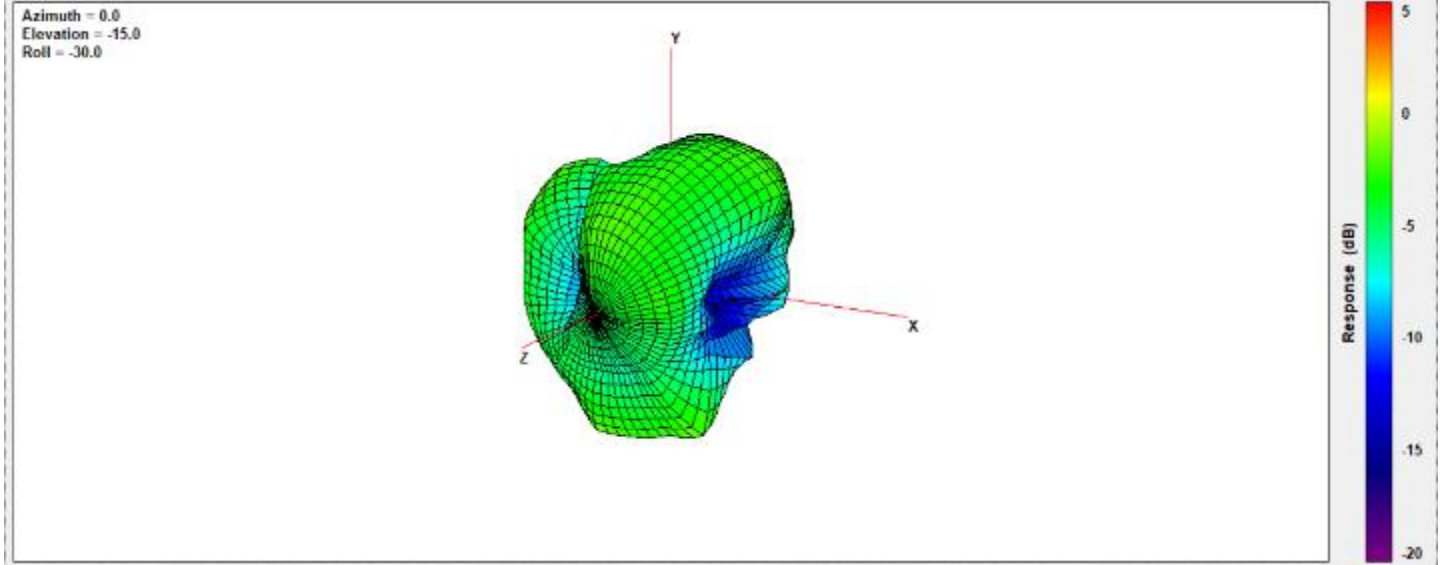

Center Frequency	<b>2350MHz</b>
Horizontal (dBi) peak	-1.69
Vertical (dBi) peak	-0.80

### 2400MHz

Total

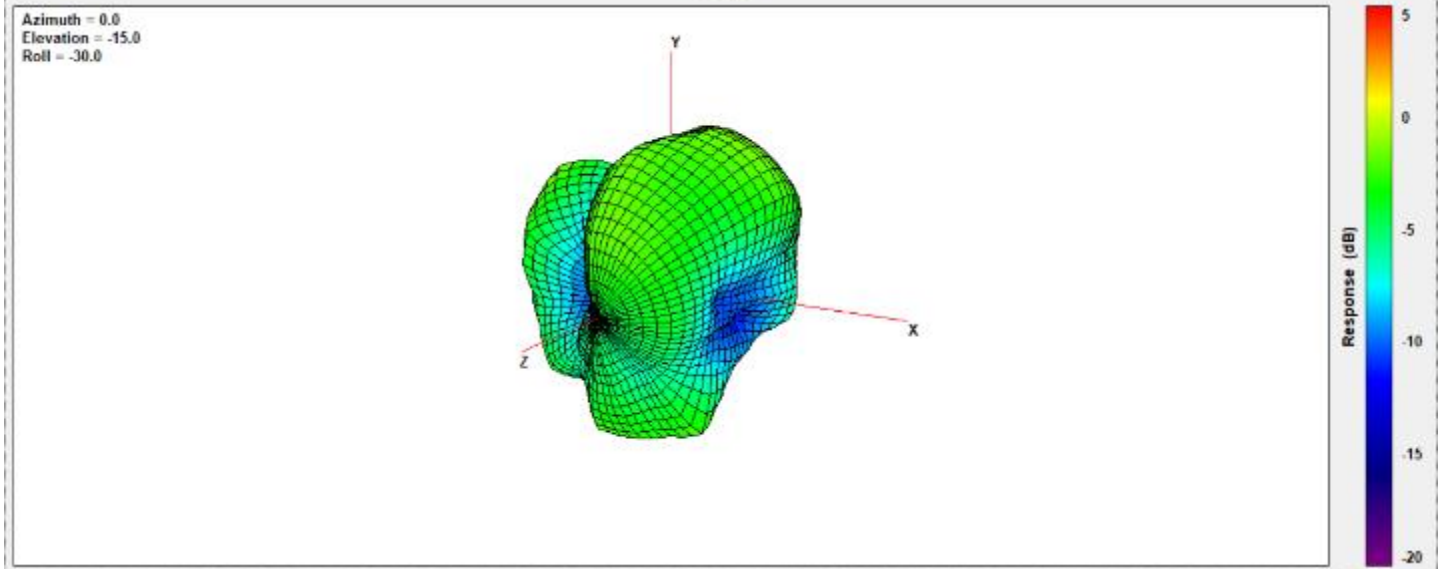

Center Frequency	<b>2400MHz</b>
Horizontal (dBi) peak	-2.46
Vertical (dBi) peak	-0.88

### 2500MHz

Total

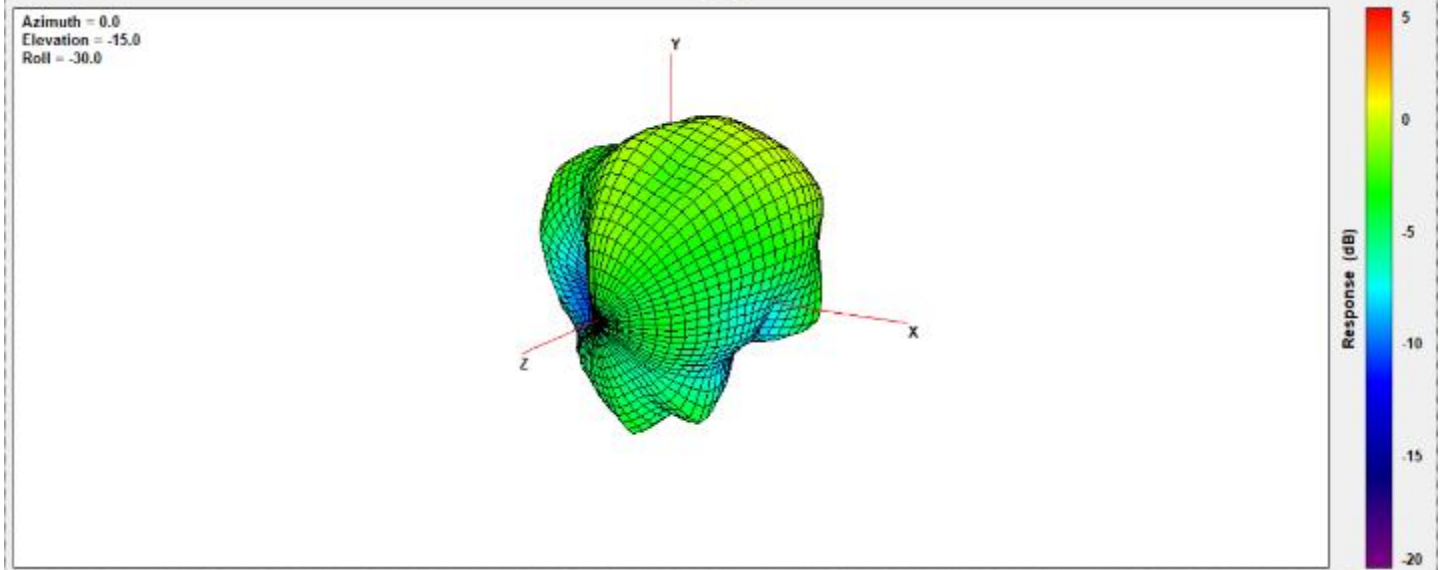

Center Frequency	<b>2500MHz</b>
Horizontal (dBi) peak	-1.61
Vertical (dBi) peak	-0.06

**2570MHz**

Total

Azimuth = 0.0  
Elevation = -15.0  
Roll = -30.0

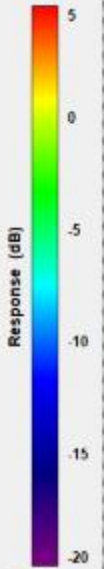
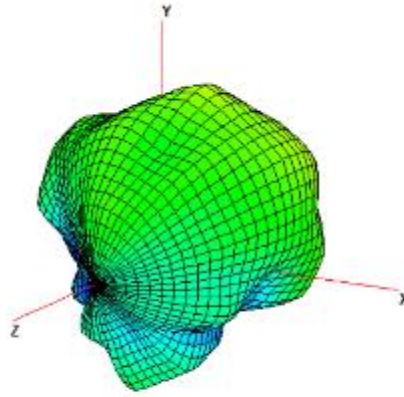

Center Frequency	<b>2570MHz</b>
Horizontal (dBi) peak	-1.99
Vertical (dBi) peak	-0.80

**2595MHz**

Total

Azimuth = 0.0  
Elevation = -15.0  
Roll = -30.0

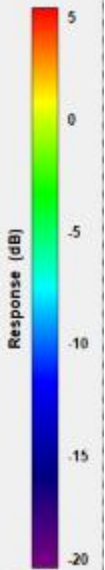
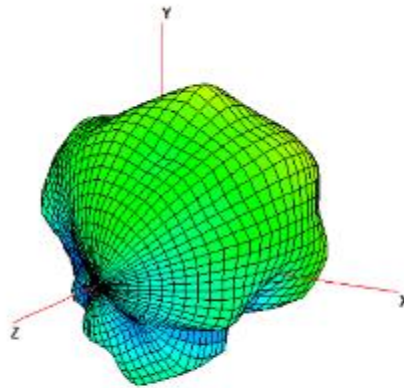

Center Frequency	<b>2595MHz</b>
Horizontal (dBi) peak	-1.64
Vertical (dBi) peak	-0.87

### 2620MHz

Total

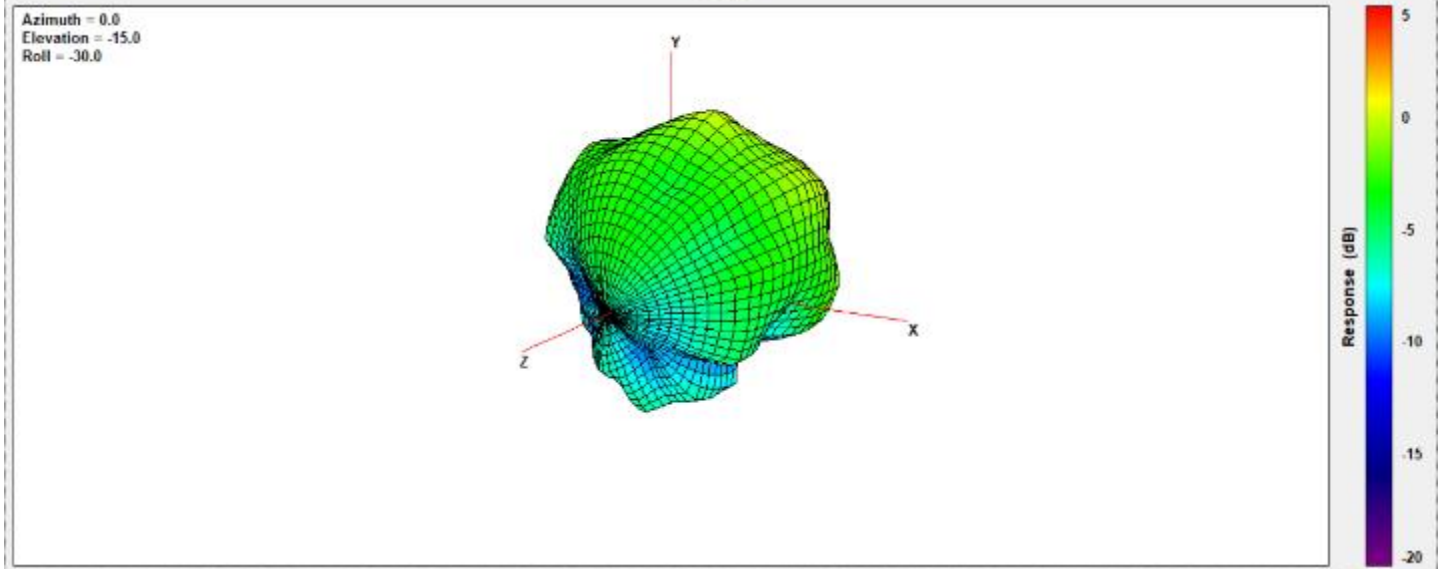

Center Frequency	<b>2620MHz</b>
Horizontal (dBi) peak	-1.35
Vertical (dBi) peak	-0.91

### 2690MHz

Total

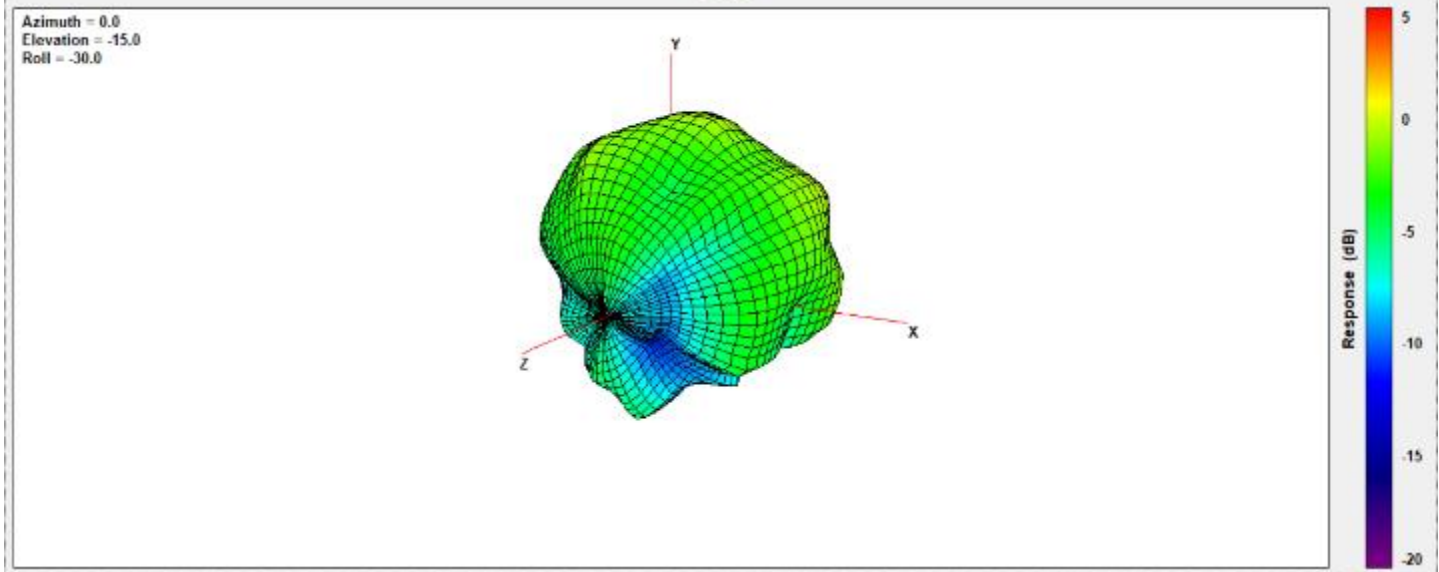

Center Frequency	<b>2690MHz</b>
Horizontal (dBi) peak	-1.05
Vertical (dBi) peak	-0.98

### 3400MHz

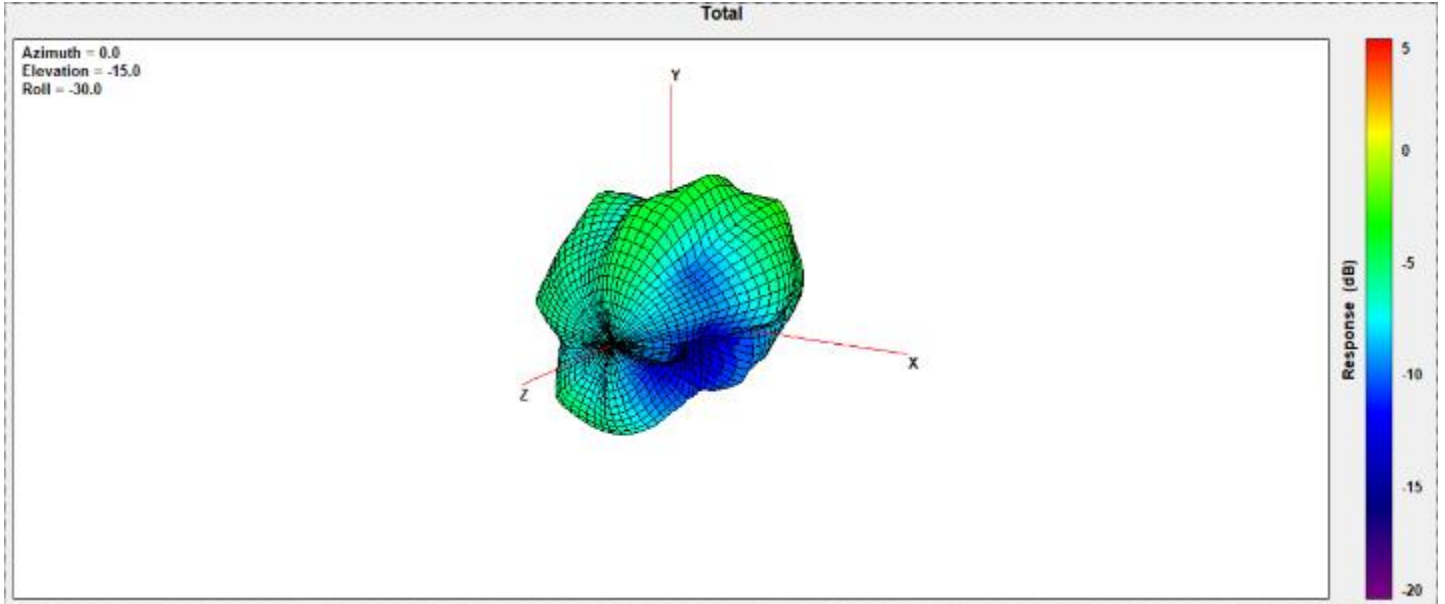

Center Frequency	<b>3400MHz</b>
Horizontal (dBi) peak	-1.88
Vertical (dBi) peak	-3.61

### 3500MHz

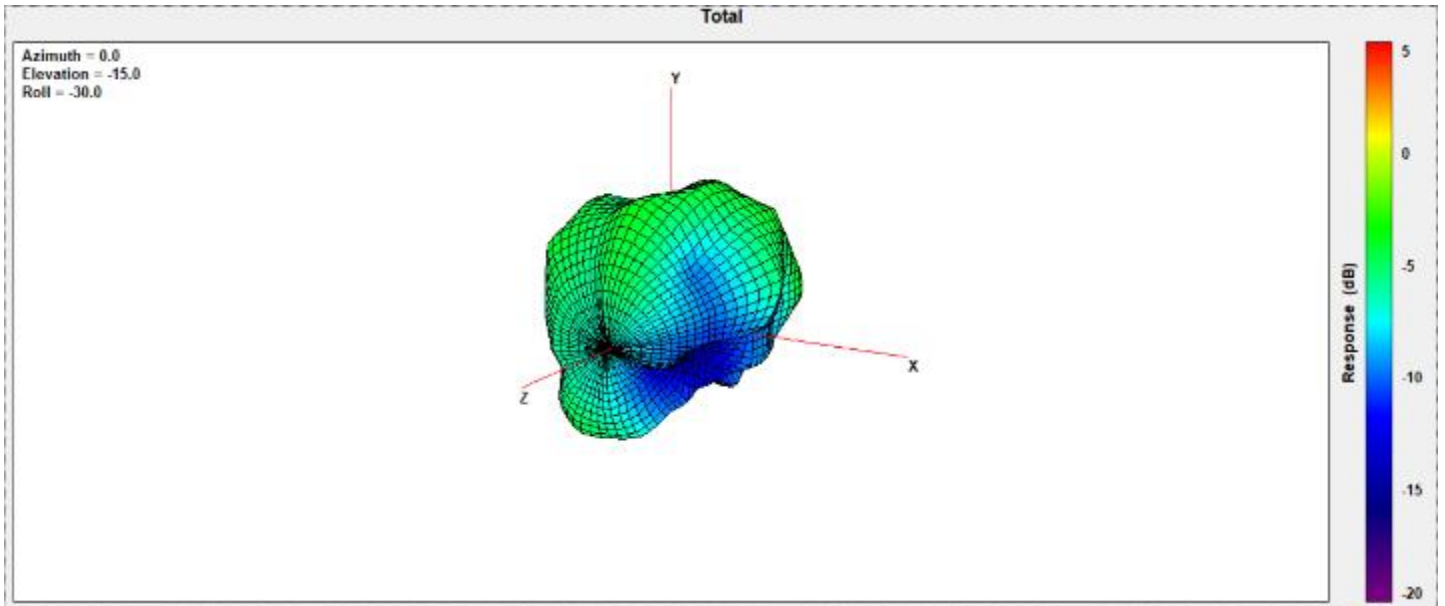

Center Frequency	<b>3500MHz</b>
Horizontal (dBi) peak	-1.68
Vertical (dBi) peak	-3.70



### 3600MHz

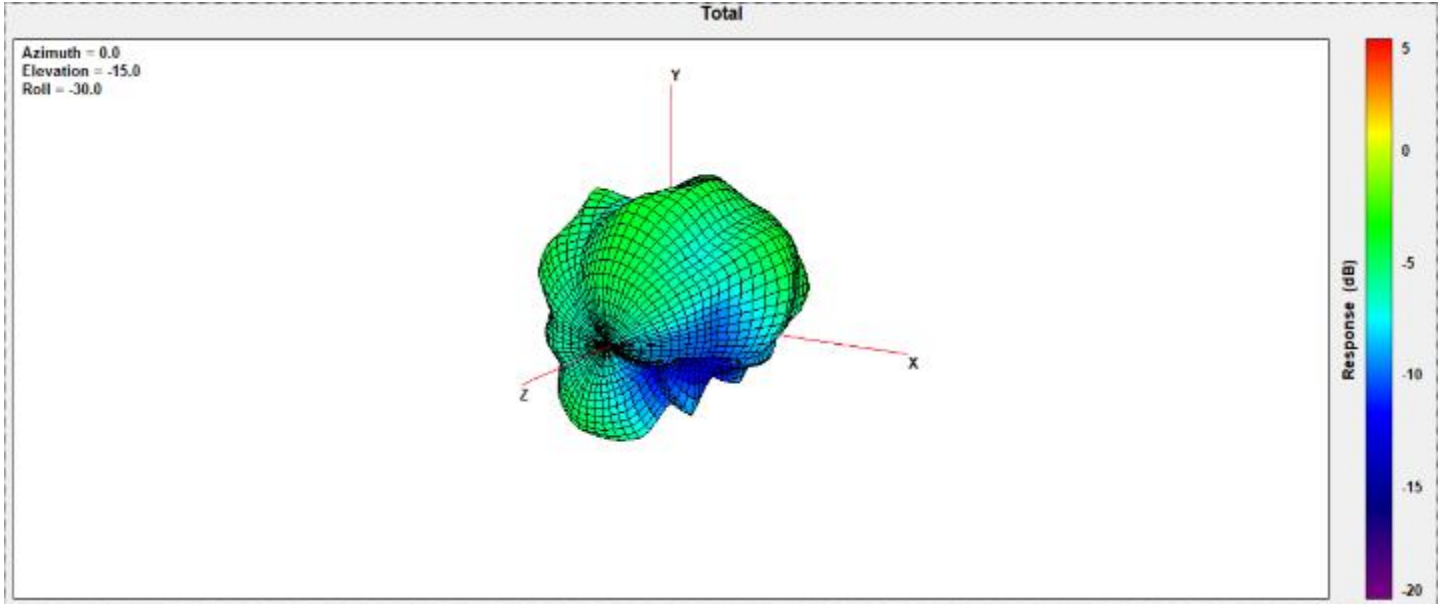

Center Frequency	<b>3600MHz</b>
Horizontal (dBi) peak	-2.06
Vertical (dBi) peak	-4.22

### 3700MHz

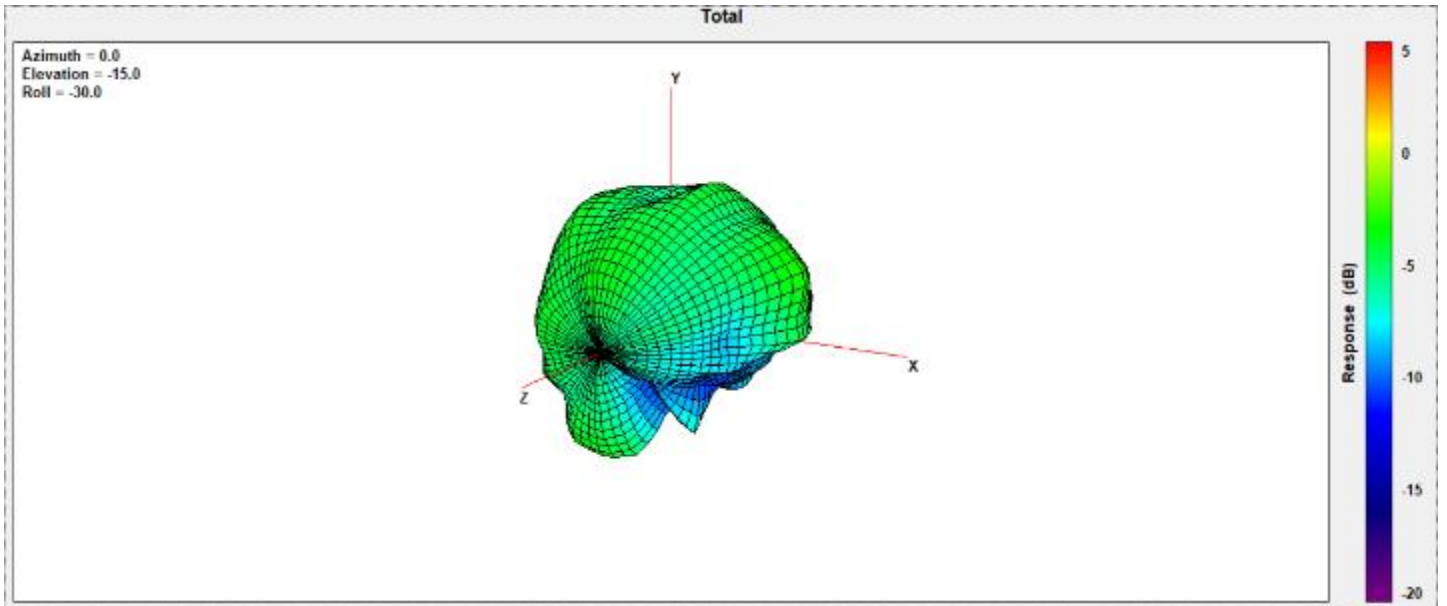

Center Frequency	<b>3700MHz</b>
Horizontal (dBi) peak	-2.67
Vertical (dBi) peak	-3.72

### 3800MHz

Total

Azimuth = 0.0  
Elevation = -15.0  
Roll = -30.0

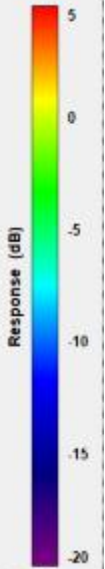
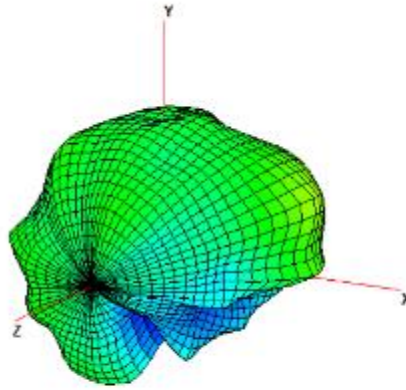

Center Frequency	<b>3800MHz</b>
Horizontal (dBi) peak	-1.50
Vertical (dBi) peak	-3.00

### 4200MHz

Total

Azimuth = 0.0  
Elevation = -15.0  
Roll = -30.0

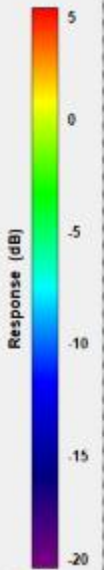
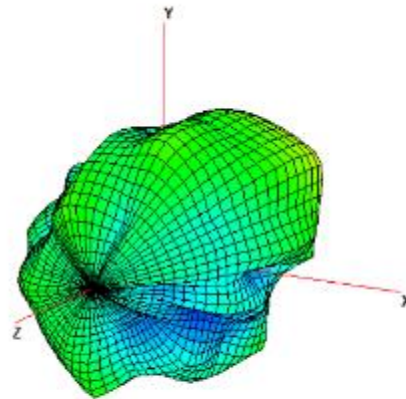

Center Frequency	<b>4200MHz</b>
Horizontal (dBi) peak	0.38
Vertical (dBi) peak	-1.67

### 4400MHz

Total

Azimuth = 0.0  
Elevation = -15.0  
Roll = -30.0

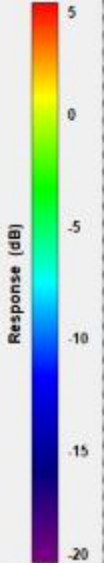
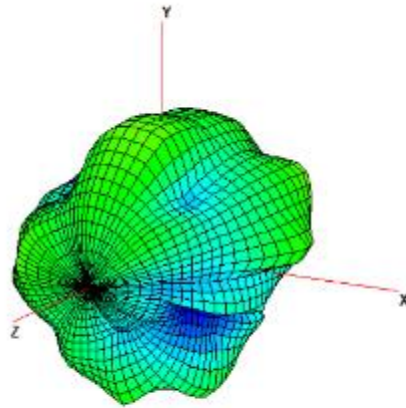

Center Frequency	<b>4400MHz</b>
Horizontal (dBi) peak	-0.18
Vertical (dBi) peak	-3.07

### 4700MHz

Total

Azimuth = 0.0  
Elevation = -15.0  
Roll = -30.0

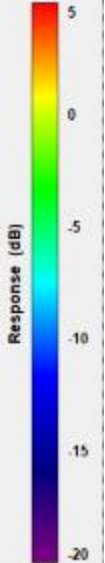
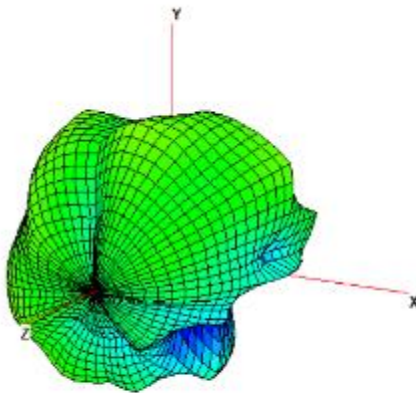

Center Frequency	<b>4700MHz</b>
Horizontal (dBi) peak	-0.84
Vertical (dBi) peak	-1.47

### 5150MHz

Total

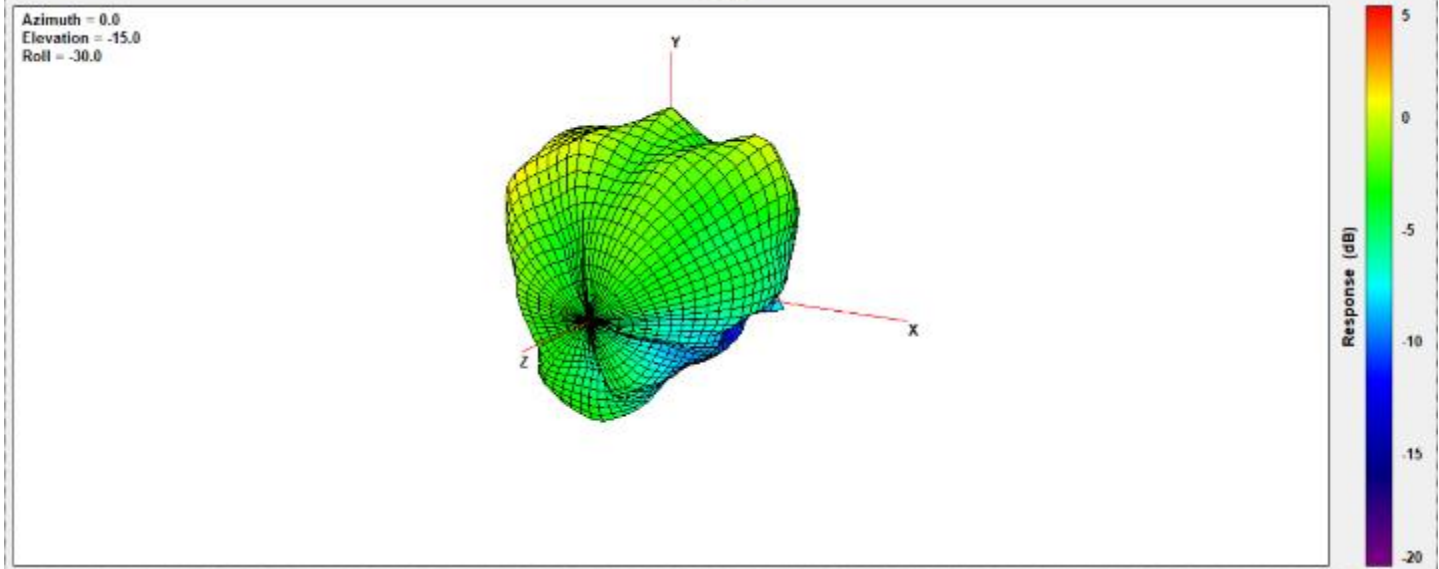

Center Frequency	<b>5150MHz</b>
Horizontal (dBi) peak	0.87
Vertical (dBi) peak	-1.51

### 5537.5MHz

Total

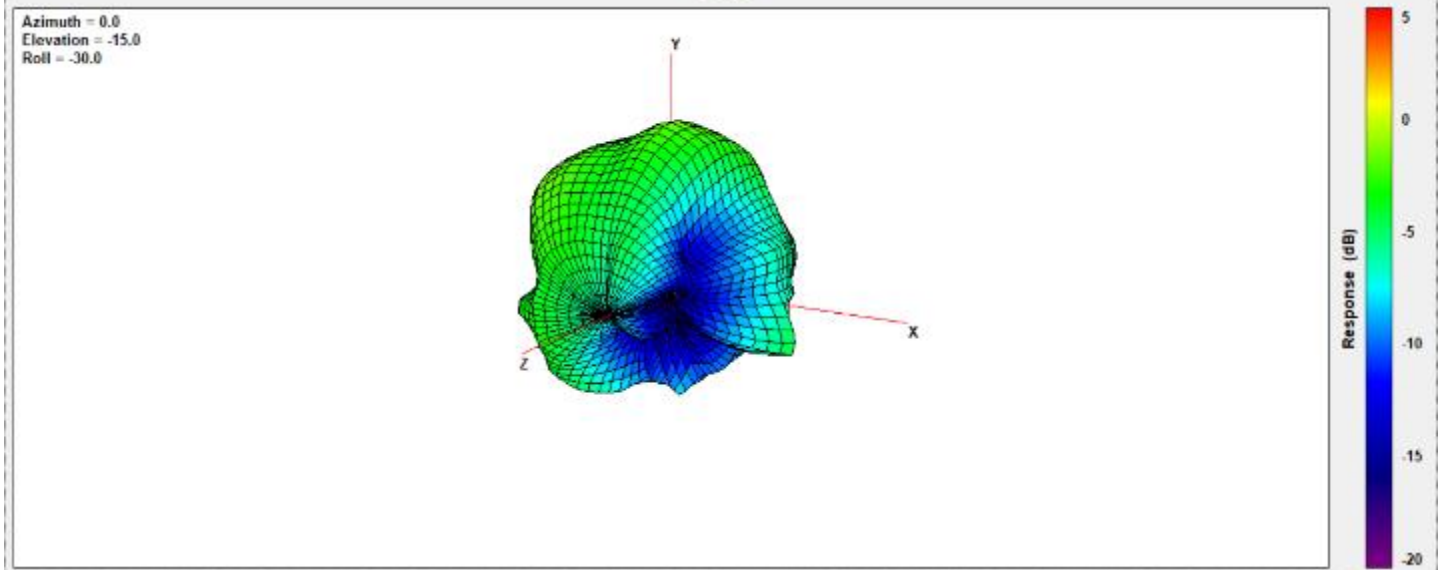

Center Frequency	<b>5537.5MHz</b>
Horizontal (dBi) peak	-2.30
Vertical (dBi) peak	-0.57

### 5925MHz

Total

Azimuth = 0.0  
Elevation = -15.0  
Roll = -30.0

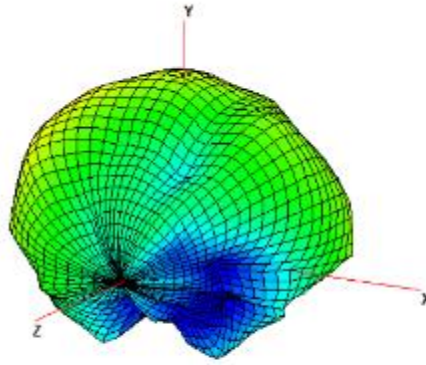

Center Frequency	<b>5925MHz</b>
Horizontal (dBi) peak	1.13
Vertical (dBi) peak	1.82

# WWAN Aux Antenna (DRx)

## 717MHz

Total

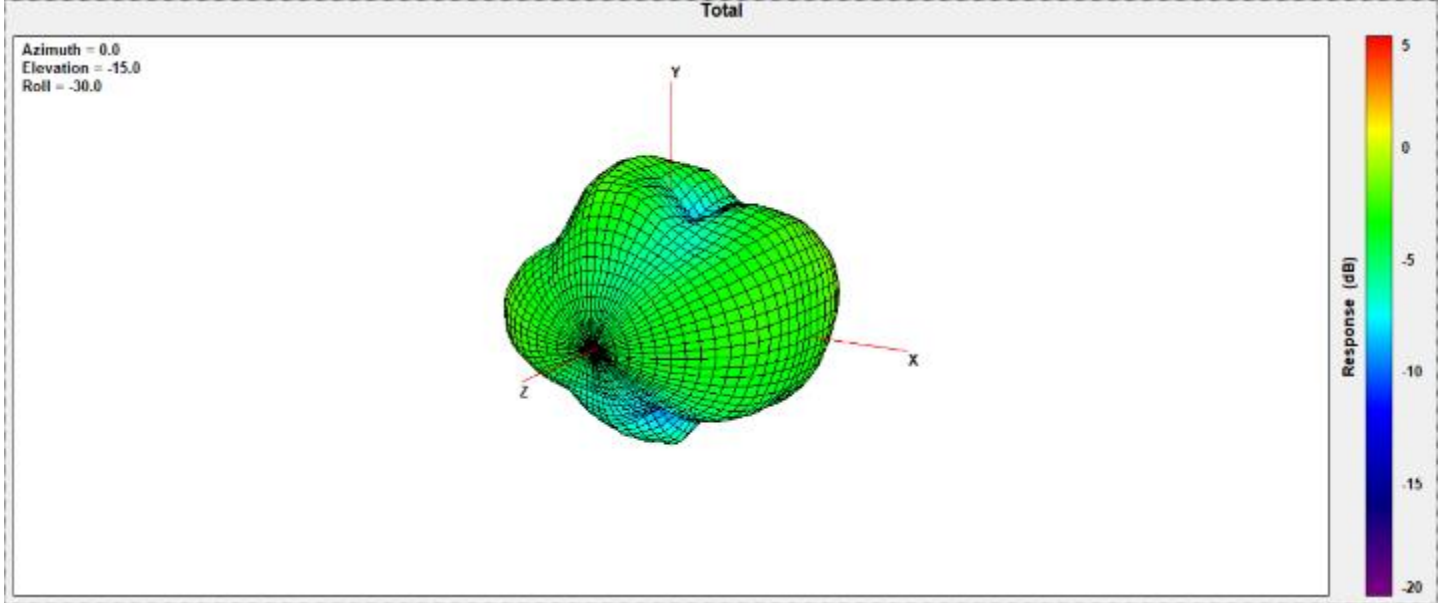

Center Frequency	<b>717MHz</b>
Horizontal (dBi) peak	-0.91
Vertical (dBi) peak	-0.49

## 725.5MHz

Total

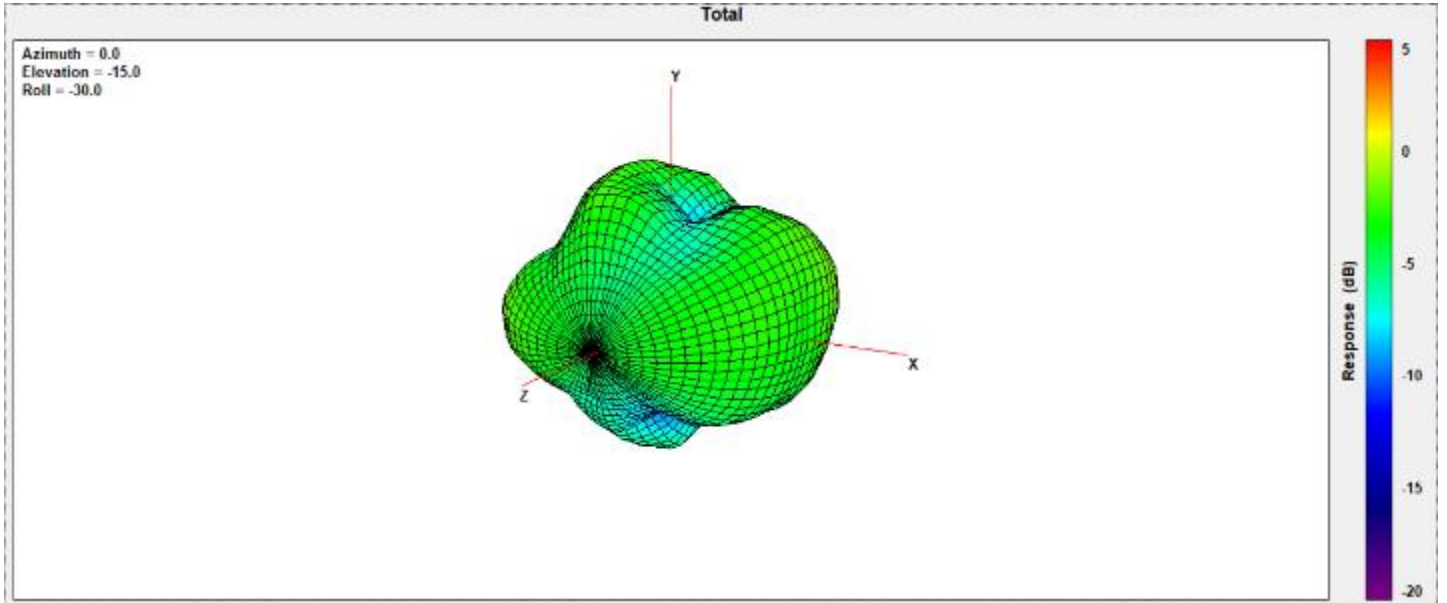

Center Frequency	<b>725.5MHz</b>
Horizontal (dBi) peak	-0.76
Vertical (dBi) peak	-0.52

### 748MHz

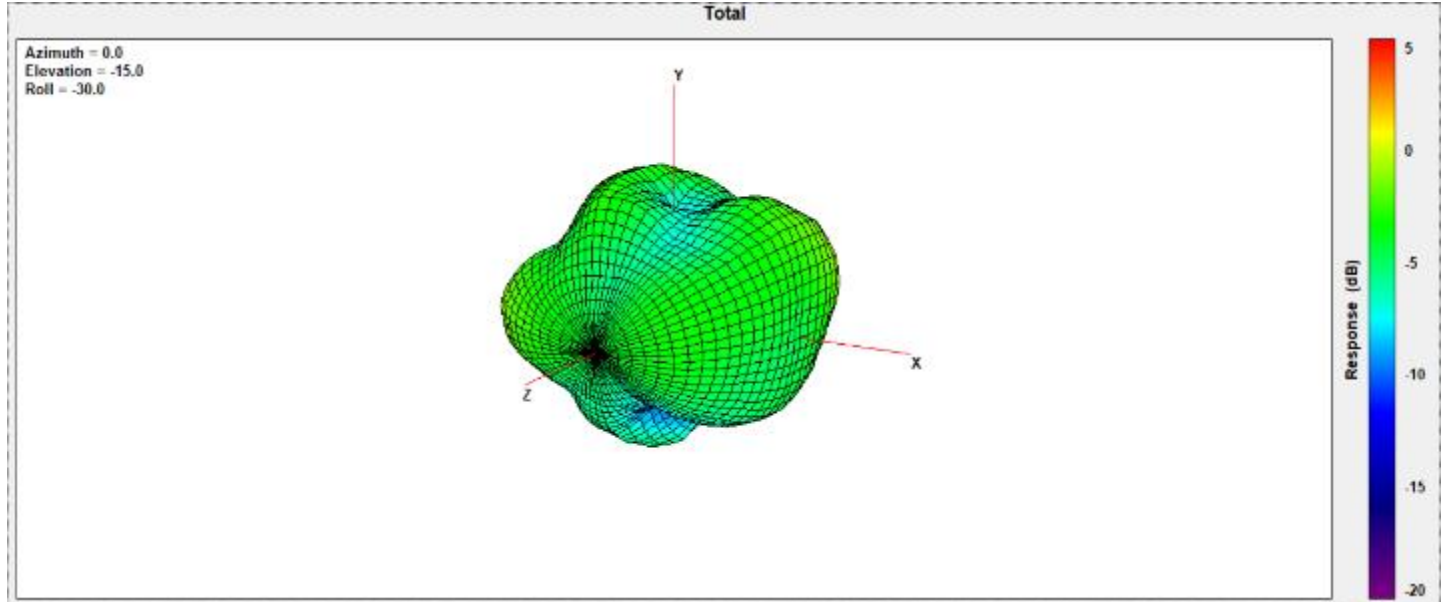

Center Frequency	<b>748MHz</b>
Horizontal (dBi) peak	-0.64
Vertical (dBi) peak	-0.41

### 756MHz

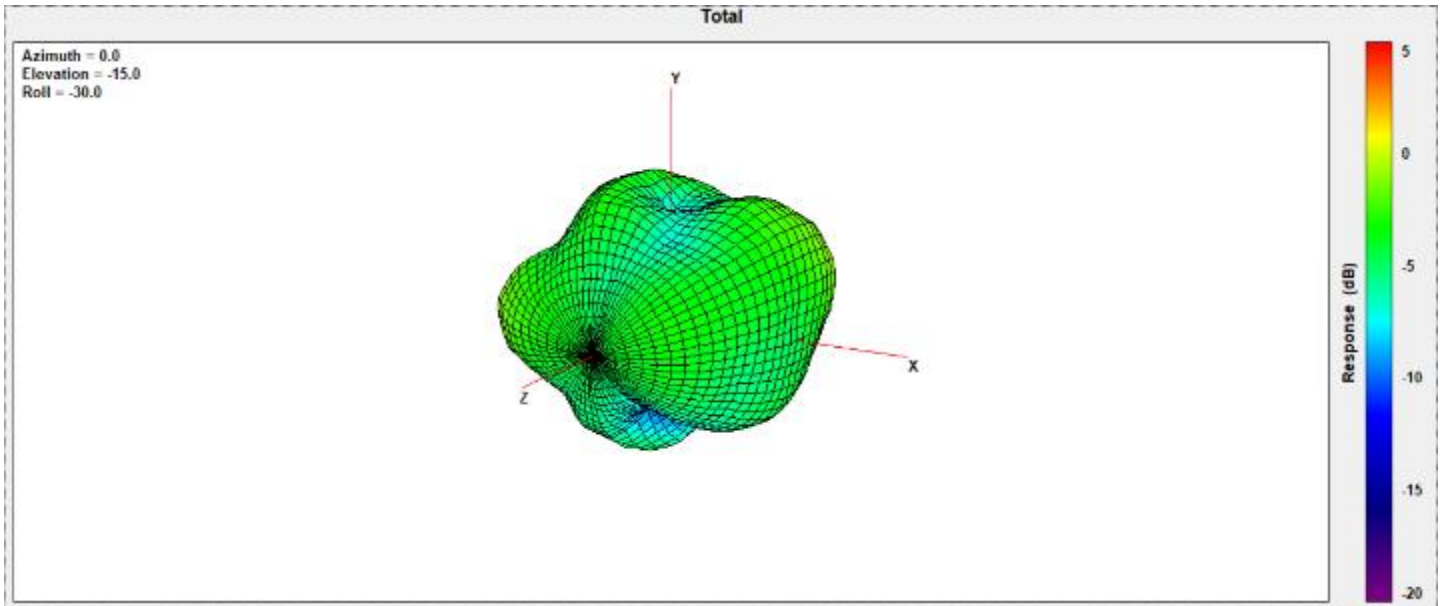

Center Frequency	<b>756MHz</b>
Horizontal (dBi) peak	-0.74
Vertical (dBi) peak	-0.37

### 768MHz

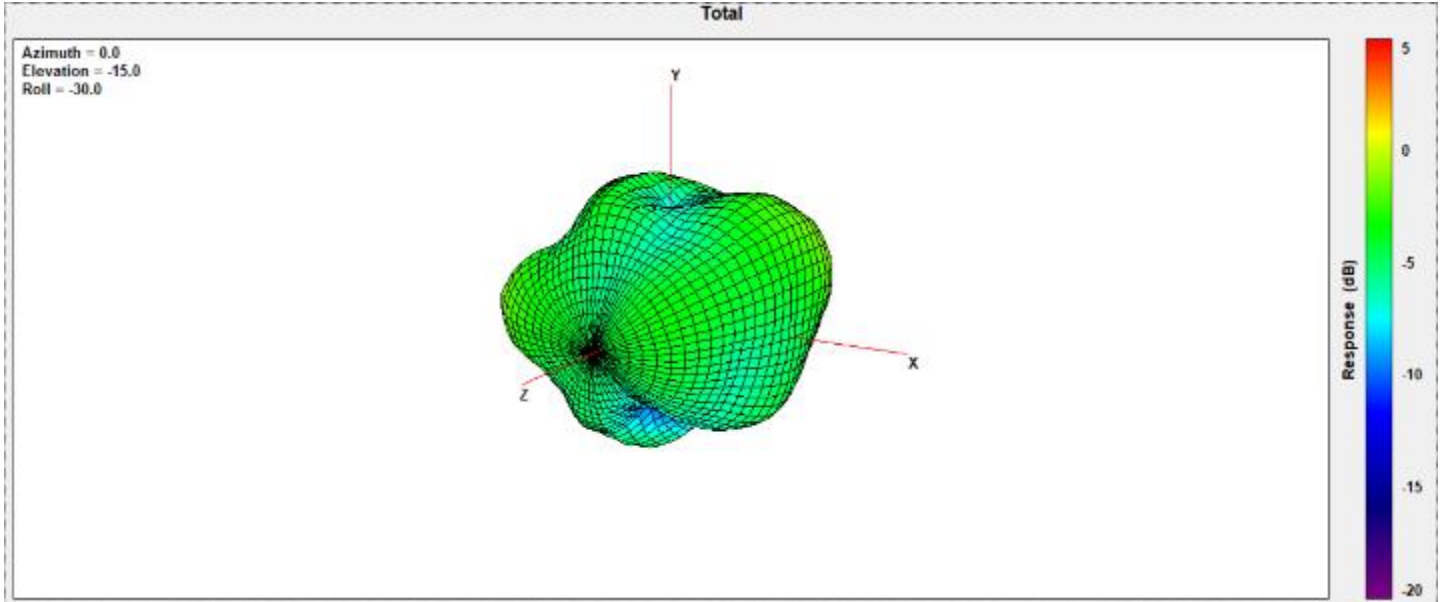

Center Frequency	<b>768MHz</b>
Horizontal (dBi) peak	-1.31
Vertical (dBi) peak	-0.54

### 777MHz

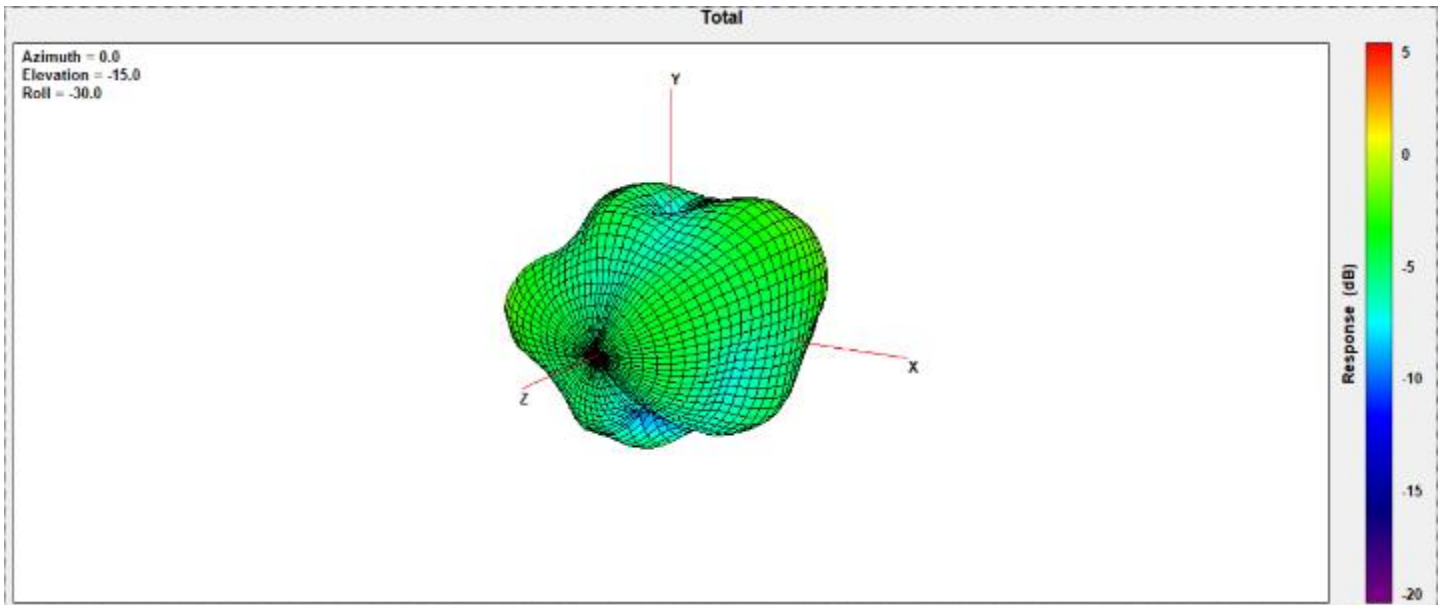

Center Frequency	<b>777MHz</b>
Horizontal (dBi) peak	-2.01
Vertical (dBi) peak	-0.96



**782MHz**

Total

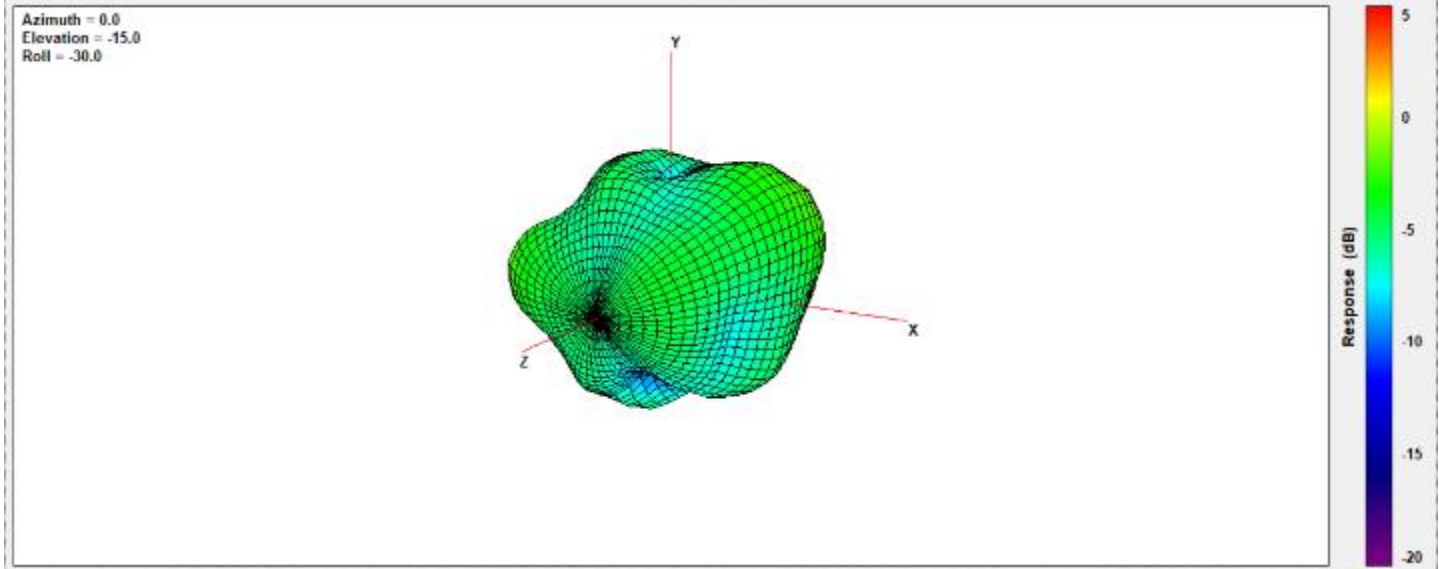

Center Frequency	<b>782MHz</b>
Horizontal (dBi) peak	-2.34
Vertical (dBi) peak	-1.14

**787MHz**

Total

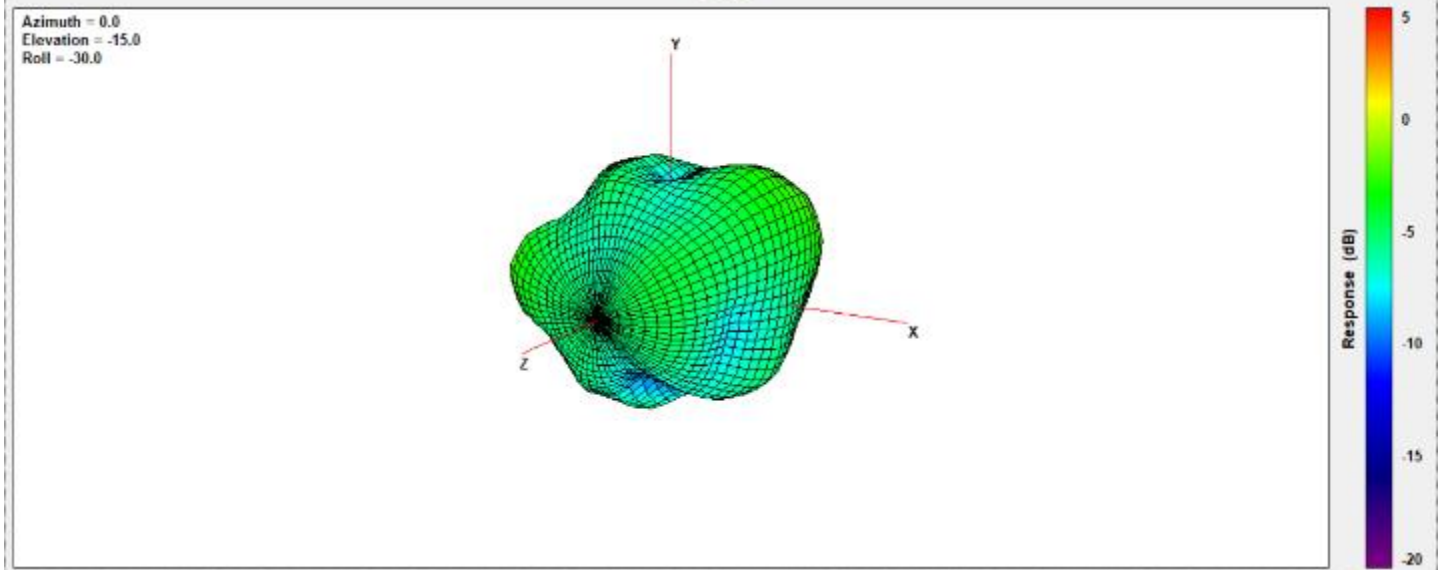

Center Frequency	<b>787MHz</b>
Horizontal (dBi) peak	-2.55
Vertical (dBi) peak	-1.43

### 814MHz

Total

Azimuth = 0.0  
Elevation = -15.0  
Roll = -30.0

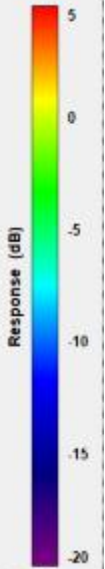
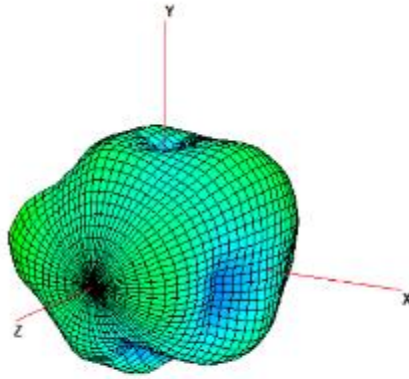

Center Frequency	<b>814MHz</b>
Horizontal (dBi) peak	-2.30
Vertical (dBi) peak	-3.08

### 824MHz

Total

Azimuth = 0.0  
Elevation = -15.0  
Roll = -30.0

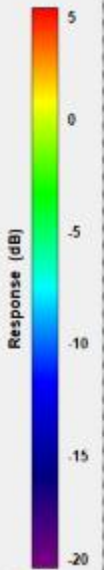
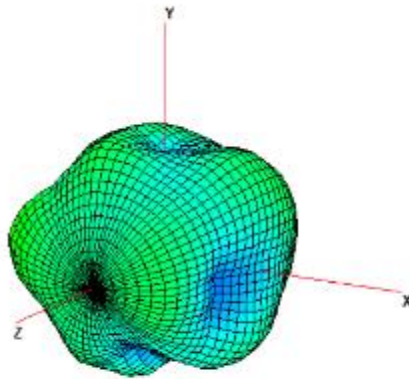

Center Frequency	<b>824MHz</b>
Horizontal (dBi) peak	-2.12
Vertical (dBi) peak	-2.89

### 832MHz

Total

Azimuth = 0.0  
Elevation = -15.0  
Roll = -30.0

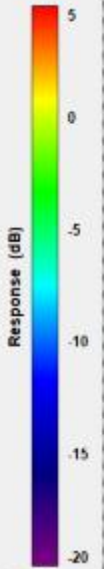
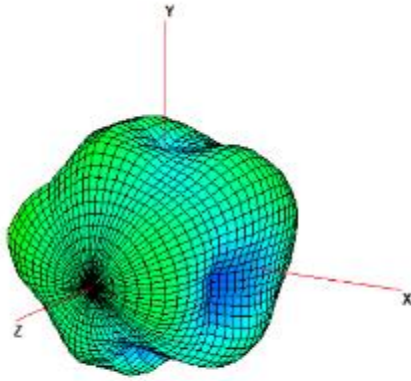

Center Frequency	<b>832MHz</b>
Horizontal (dBi) peak	-1.87
Vertical (dBi) peak	-2.81

### 836.5MHz

Total

Azimuth = 0.0  
Elevation = -15.0  
Roll = -30.0

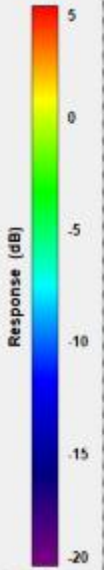
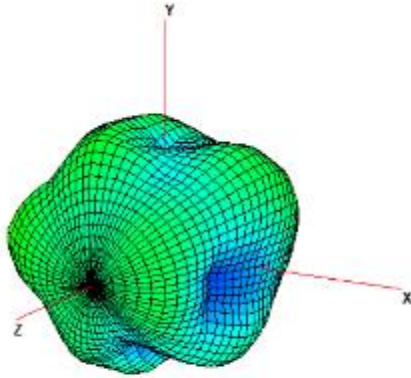

Center Frequency	<b>836.5MHz</b>
Horizontal (dBi) peak	-1.84
Vertical (dBi) peak	-2.51

### 849MHz

Total

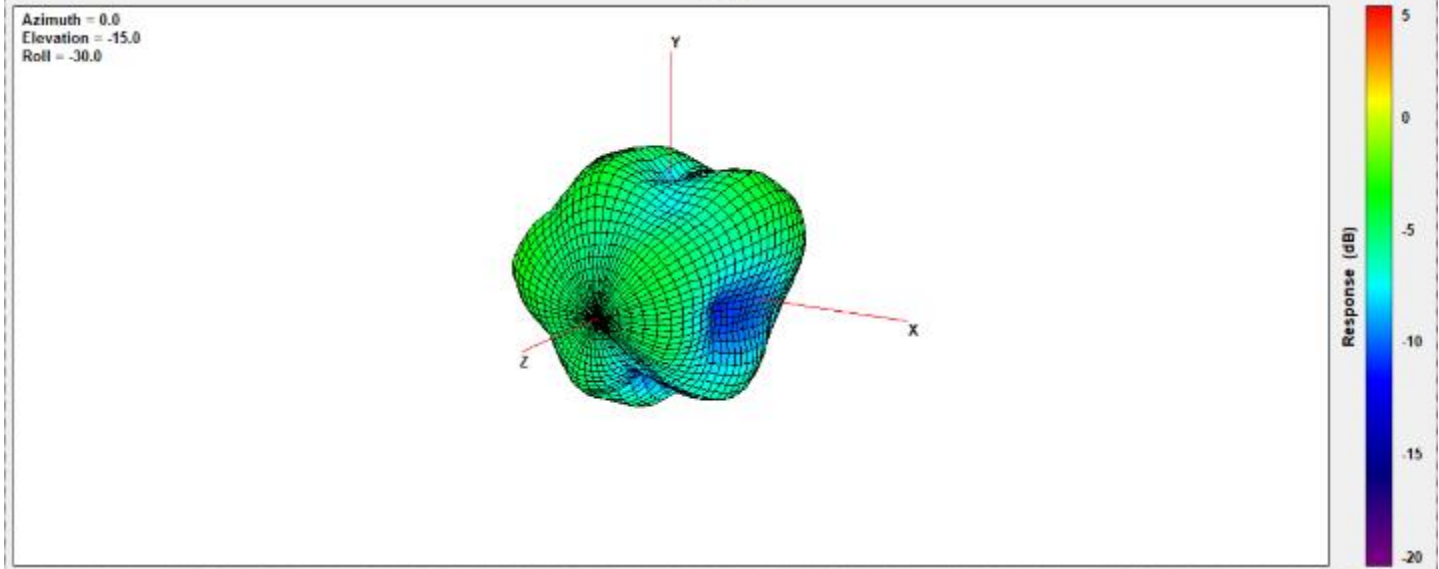

Center Frequency	<b>849MHz</b>
Horizontal (dBi) peak	-1.79
Vertical (dBi) peak	-1.87

### 862MHz

Total

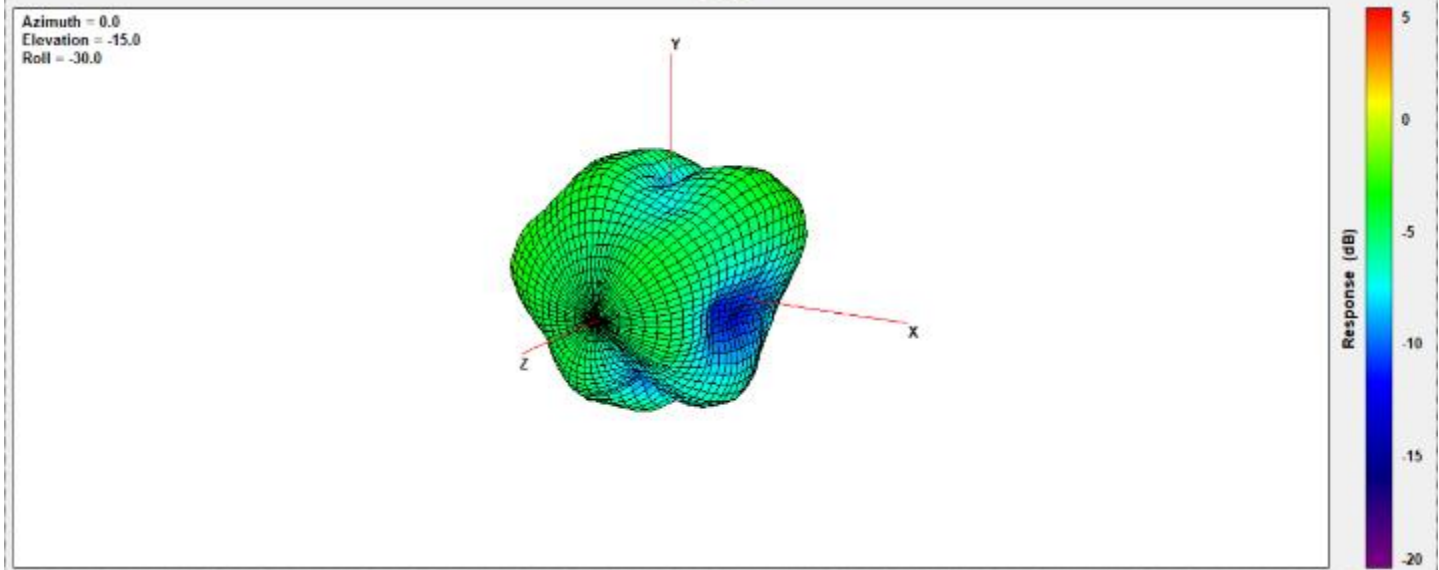

Center Frequency	<b>862MHz</b>
Horizontal (dBi) peak	-1.57
Vertical (dBi) peak	-1.54

### 880MHz

Total

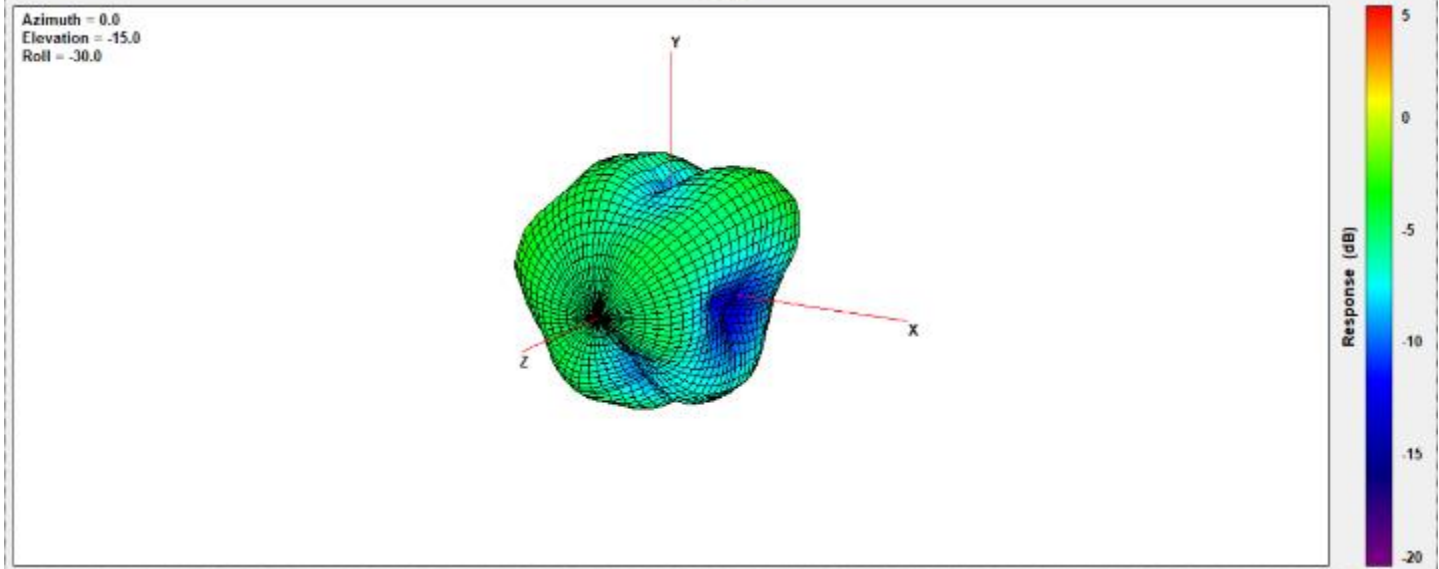

Center Frequency	<b>880MHz</b>
Horizontal (dBi) peak	-1.63
Vertical (dBi) peak	-1.87

### 897.5MHz

Total

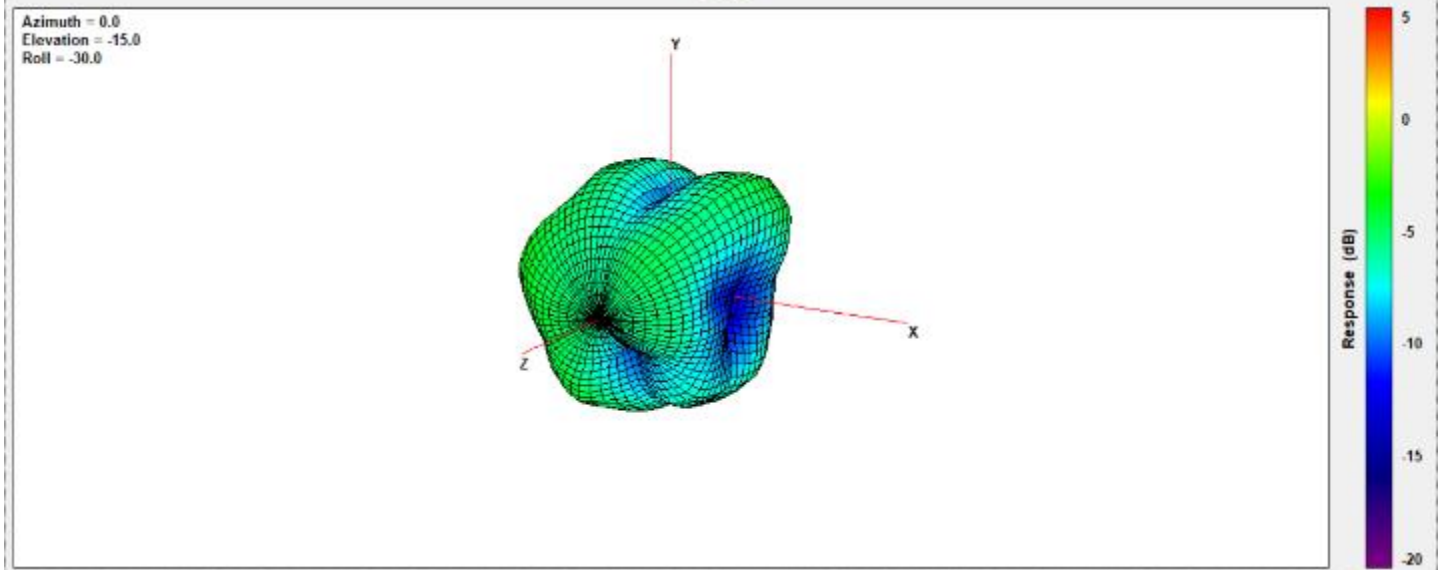

Center Frequency	<b>897.5MHz</b>
Horizontal (dBi) peak	-1.98
Vertical (dBi) peak	-2.14

**915MHz**

Total

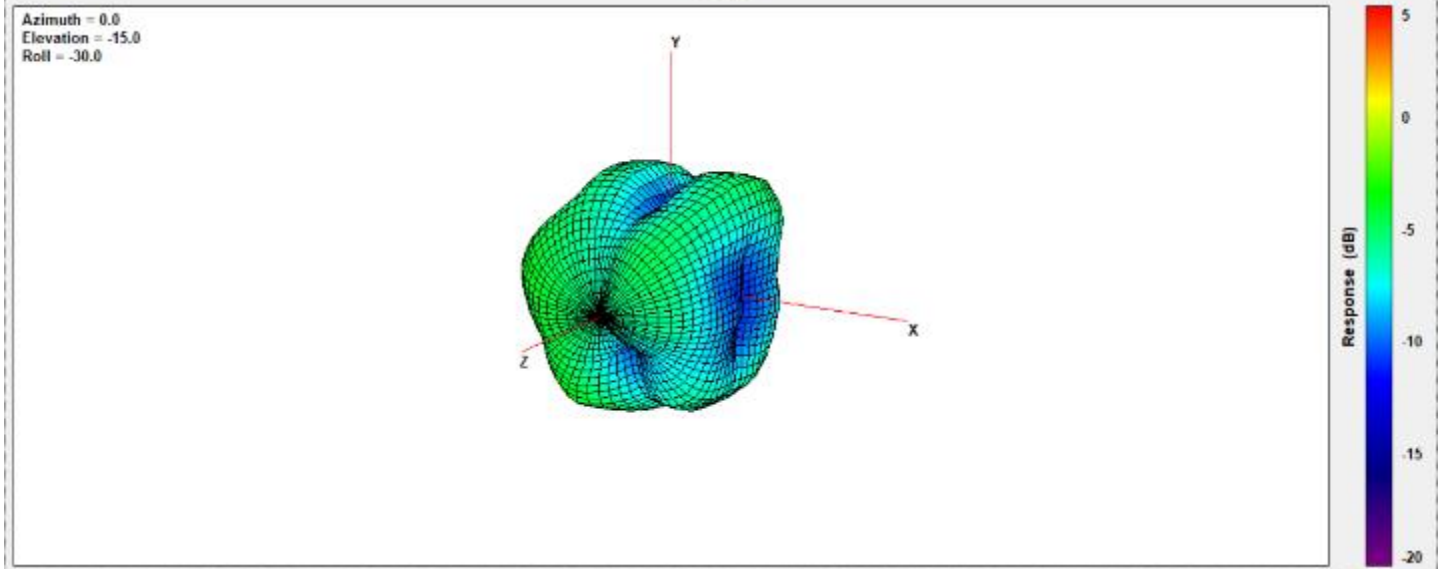

Center Frequency	<b>915MHz</b>
Horizontal (dBi) peak	-2.54
Vertical (dBi) peak	-2.29

**925MHz**

Total

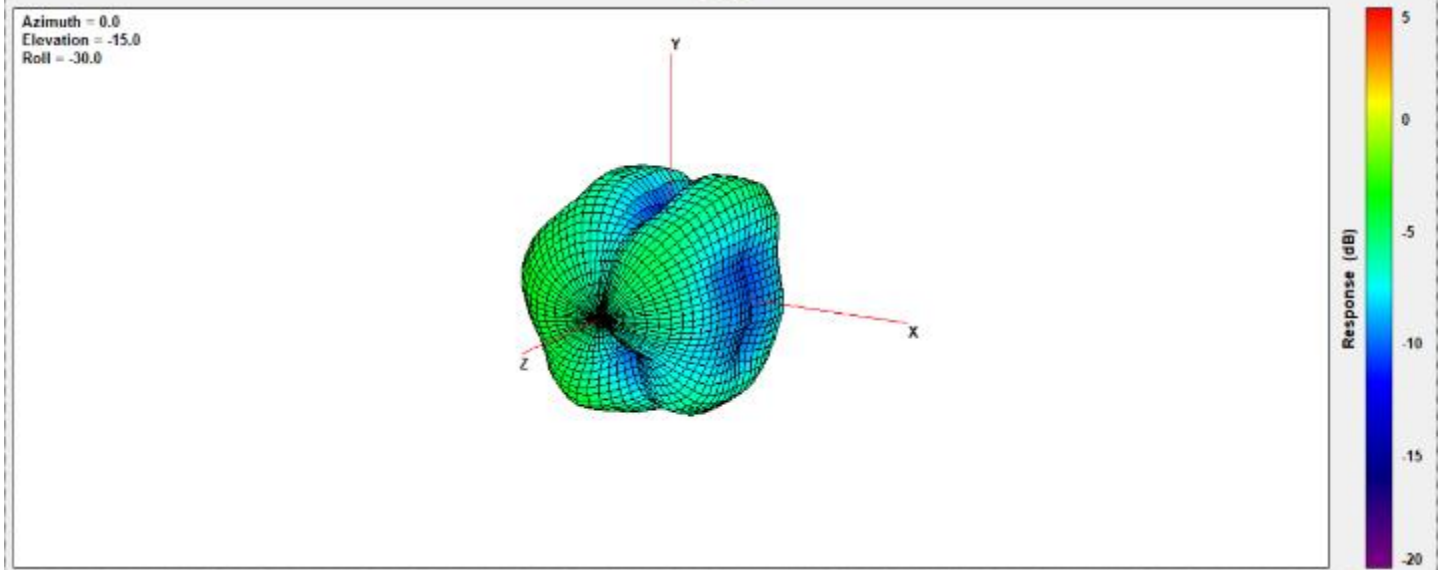

Center Frequency	<b>925MHz</b>
Horizontal (dBi) peak	-2.91
Vertical (dBi) peak	-2.30

**960MHz**

Total

Azimuth = 0.0  
Elevation = -15.0  
Roll = -30.0

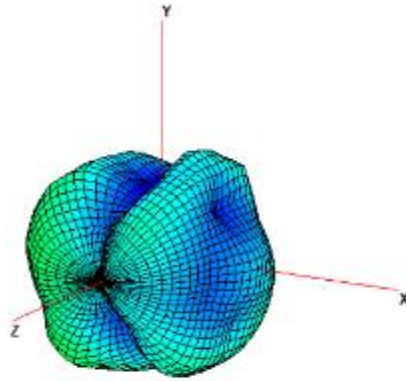

Center Frequency	<b>960MHz</b>
Horizontal (dBi) peak	-5.30
Vertical (dBi) peak	-3.72

**1427.9MHz**

Total

Azimuth = 0.0  
Elevation = -15.0  
Roll = -30.0

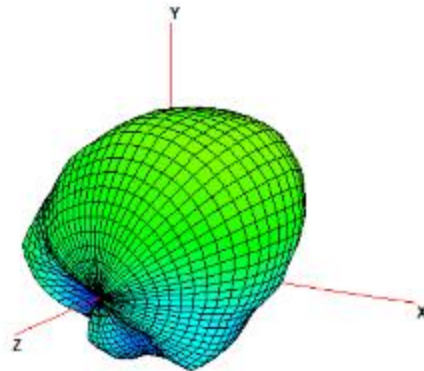

Center Frequency	<b>1427.9MHz</b>
Horizontal (dBi) peak	-4.03
Vertical (dBi) peak	-1.20

**1447.9MHz**

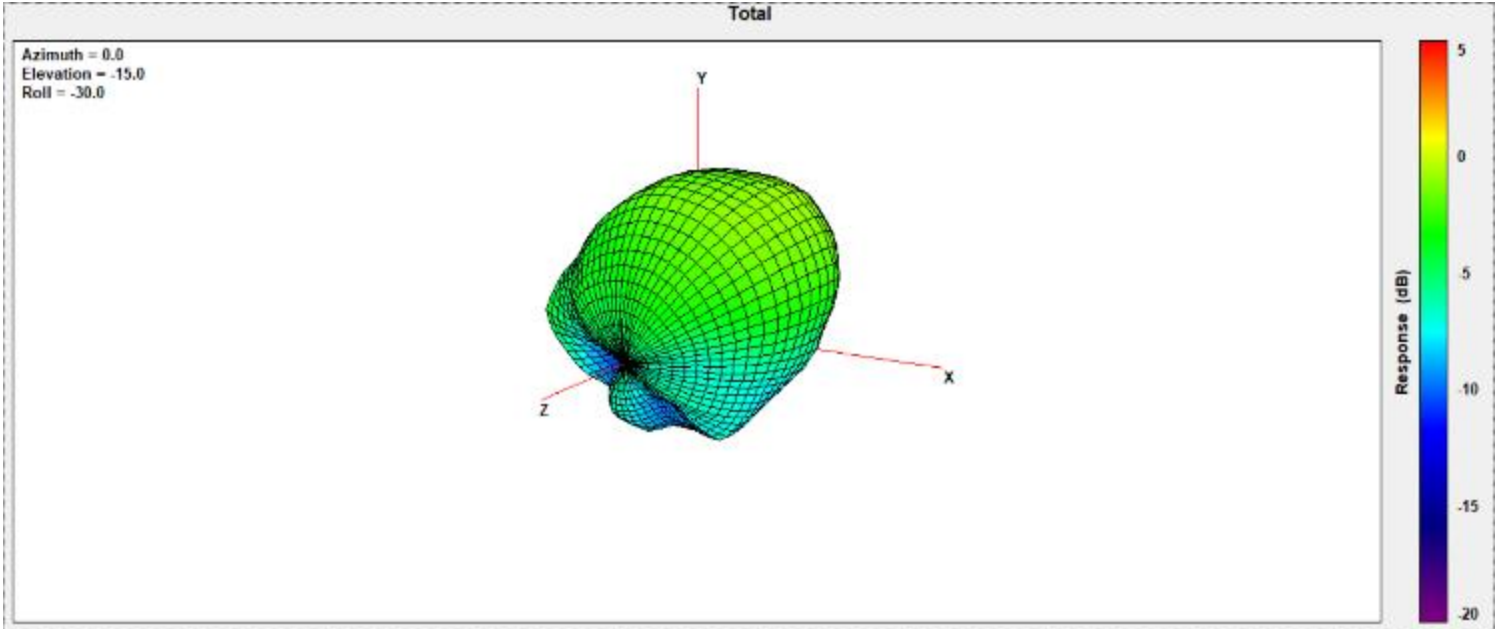

Center Frequency	<b>1447.9MHz</b>
Horizontal (dBi) peak	-3.84
Vertical (dBi) peak	-0.71

**1455.4MHz**

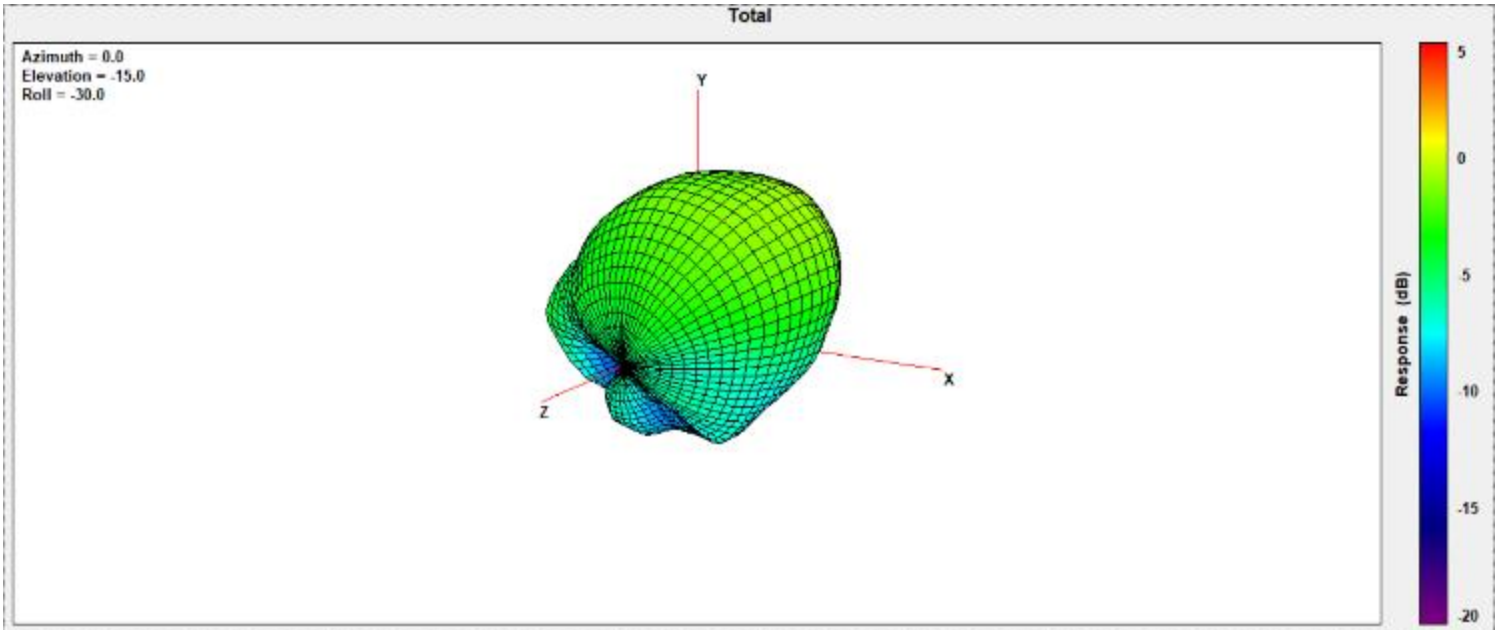

Center Frequency	<b>1455.4MHz</b>
Horizontal (dBi) peak	-3.68
Vertical (dBi) peak	-0.62



**1462.9MHz**

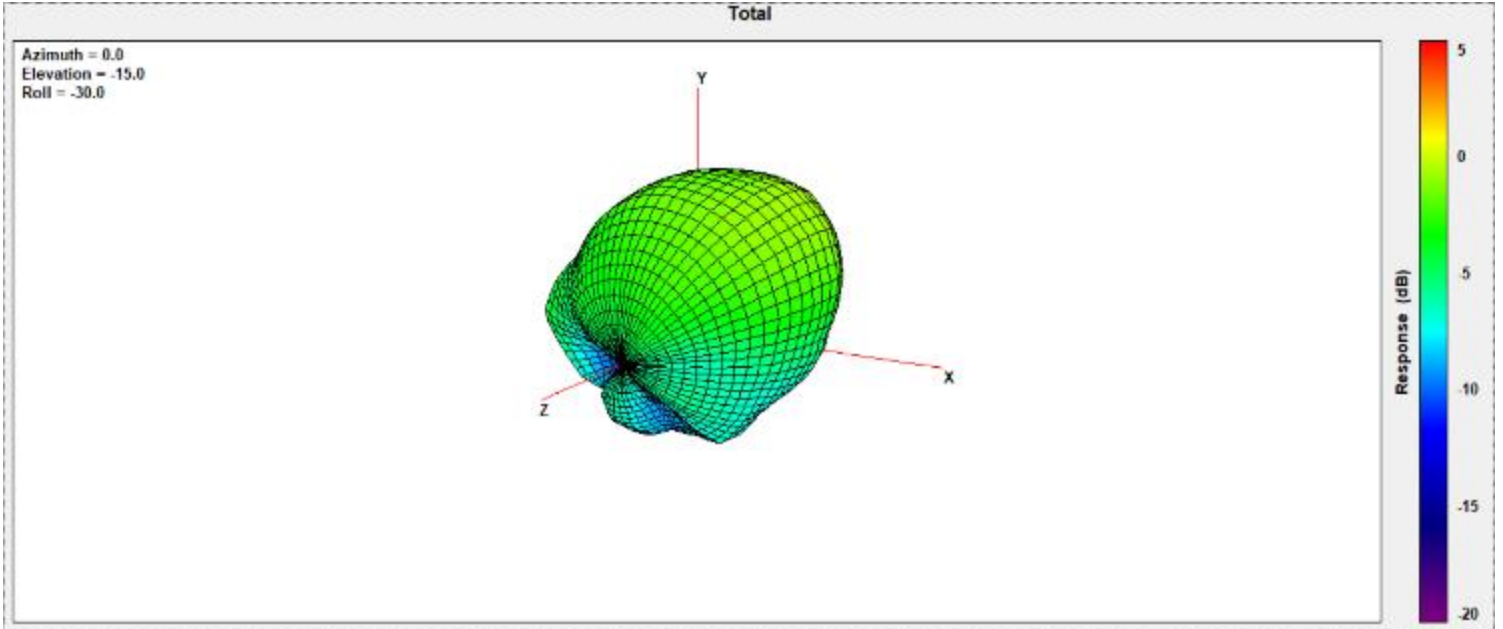

Center Frequency	<b>1462.9MHz</b>
Horizontal (dBi) peak	-3.56
Vertical (dBi) peak	-0.54

**1496MHz**

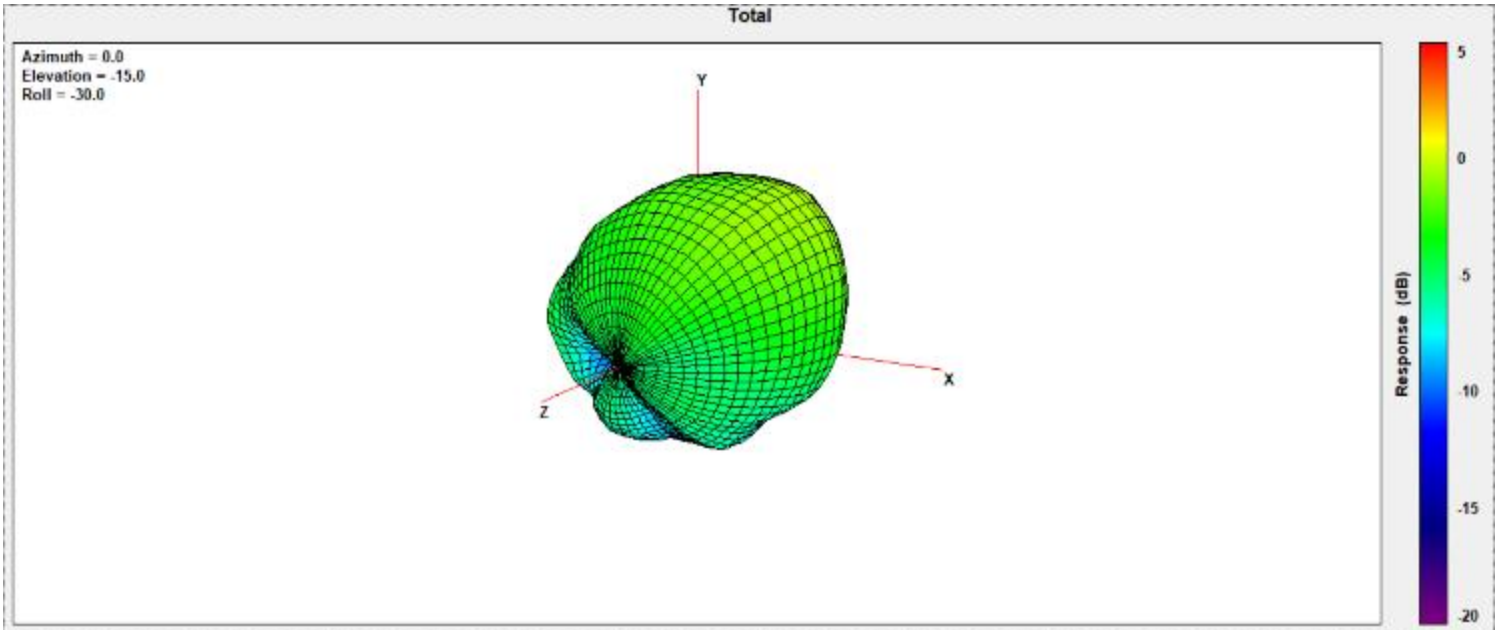

Center Frequency	<b>1496MHz</b>
Horizontal (dBi) peak	-3.84
Vertical (dBi) peak	-0.45

**1510.9MHz**

Total

Azimuth = 0.0  
Elevation = -15.0  
Roll = -30.0

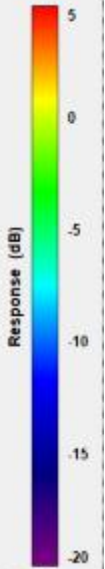
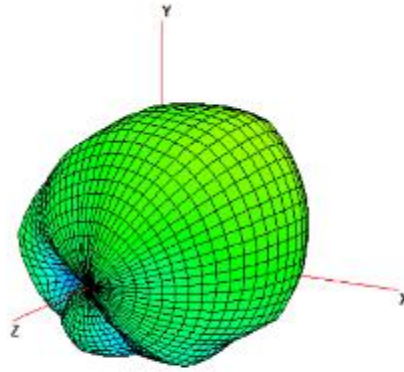

Center Frequency	<b>1510.9MHz</b>
Horizontal (dBi) peak	-4.33
Vertical (dBi) peak	-0.73

**1557MHz**

Total

Azimuth = 0.0  
Elevation = -15.0  
Roll = -30.0

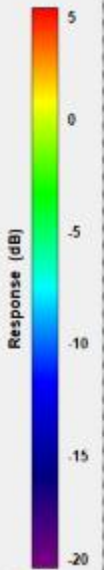
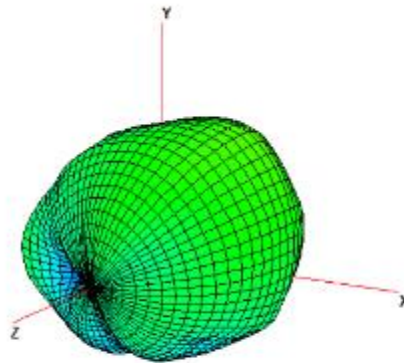

Center Frequency	<b>1557MHz</b>
Horizontal (dBi) peak	-4.78
Vertical (dBi) peak	-1.95

### 1575MHz

Total

Azimuth = 0.0  
Elevation = -15.0  
Roll = -30.0

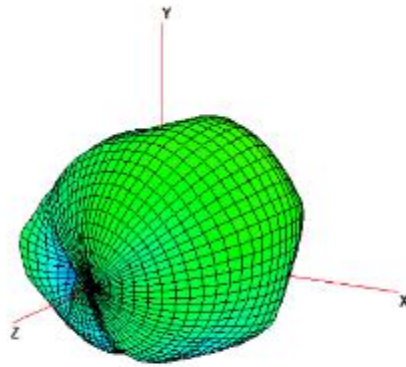

Center Frequency	<b>1575MHz</b>
Horizontal (dBi) peak	-4.32
Vertical (dBi) peak	-2.46

### 1610MHz

Total

Azimuth = 0.0  
Elevation = -15.0  
Roll = -30.0

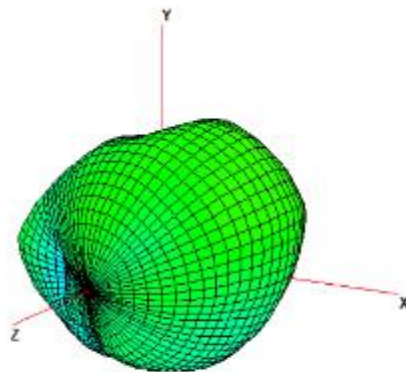

Center Frequency	<b>1610MHz</b>
Horizontal (dBi) peak	-3.45
Vertical (dBi) peak	-2.52

### 1805 MHz

Total

Azimuth = 0.0  
Elevation = -15.0  
Roll = -30.0

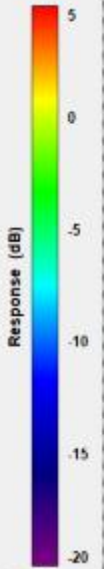
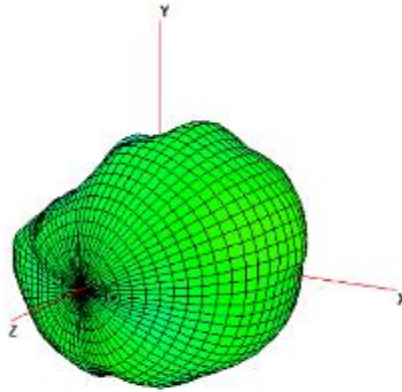

Center Frequency	<b>1805 MHz</b>
Horizontal (dBi) peak	-4.65
Vertical (dBi) peak	-2.70

### 1850 MHz

Total

Azimuth = 0.0  
Elevation = -15.0  
Roll = -30.0

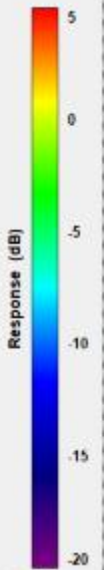
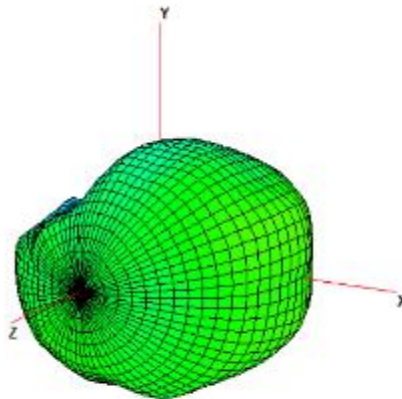

Center Frequency	<b>1850 MHz</b>
Horizontal (dBi) peak	-4.05
Vertical (dBi) peak	-2.03

### 1880 MHz

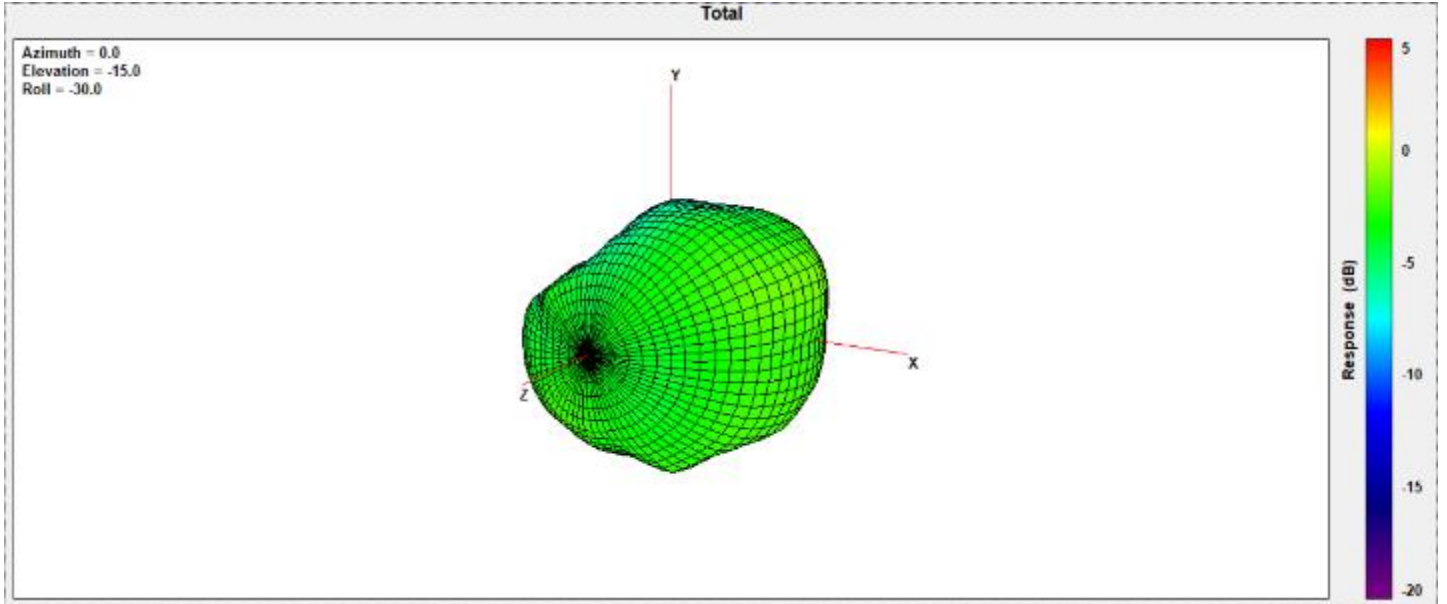

Center Frequency	<b>1880 MHz</b>
Horizontal (dBi) peak	-3.41
Vertical (dBi) peak	-1.18

### 1910MHz

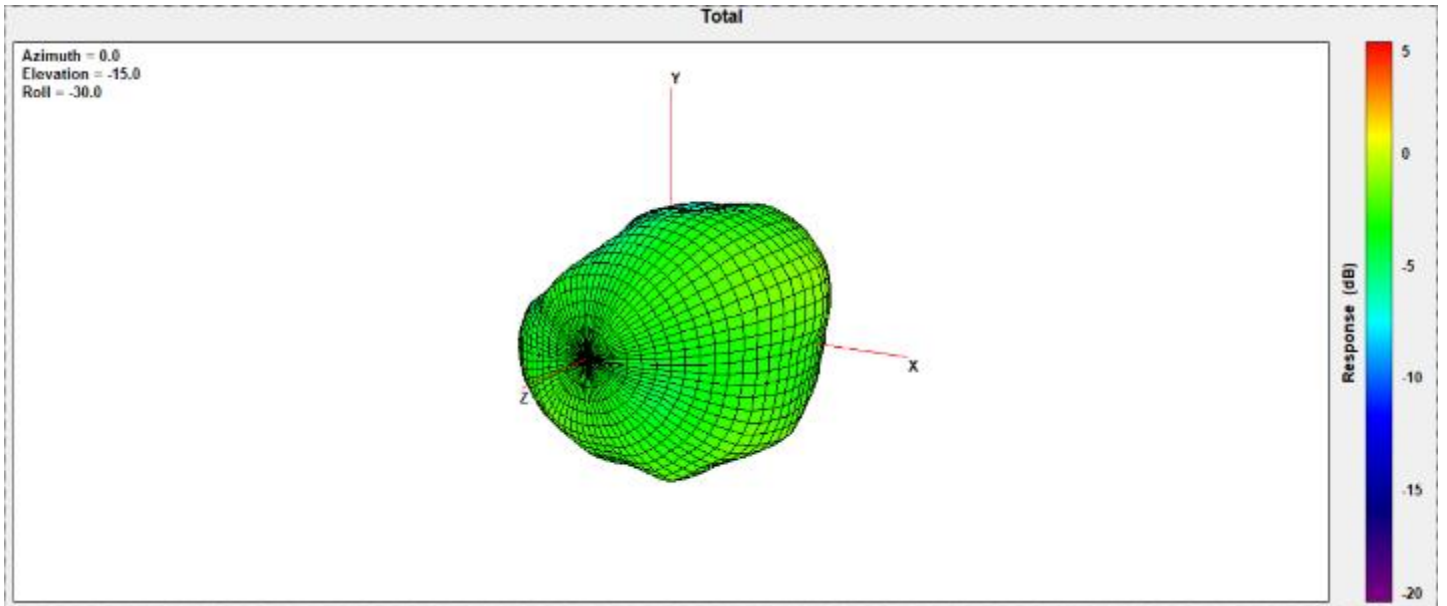

Center Frequency	<b>1910MHz</b>
Horizontal (dBi) peak	-2.45
Vertical (dBi) peak	-0.85

### 1920MHz

Total

Azimuth = 0.0  
Elevation = -15.0  
Roll = -30.0

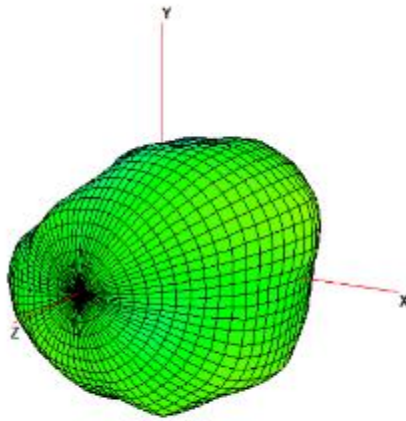

Center Frequency	<b>1920MHz</b>
Horizontal (dBi) peak	-2.39
Vertical (dBi) peak	-0.98

### 1950MHz

Total

Azimuth = 0.0  
Elevation = -15.0  
Roll = -30.0

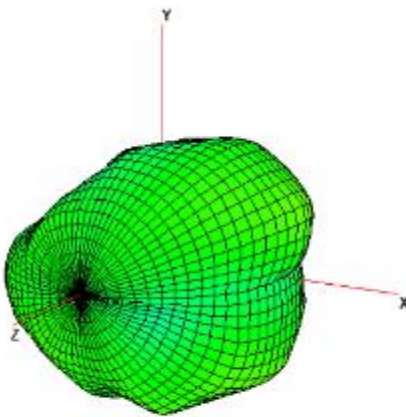

Center Frequency	<b>1950MHz</b>
Horizontal (dBi) peak	-2.23
Vertical (dBi) peak	-1.48

### 1980MHz

Total

Azimuth = 0.0  
Elevation = -15.0  
Roll = -30.0

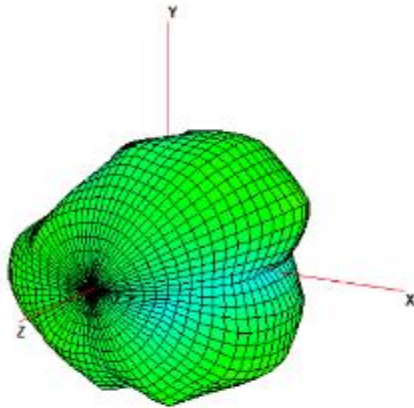

Center Frequency	<b>1980MHz</b>
Horizontal (dBi) peak	-2.49
Vertical (dBi) peak	-1.65

### 2110MHz

Total

Azimuth = 0.0  
Elevation = -15.0  
Roll = -30.0

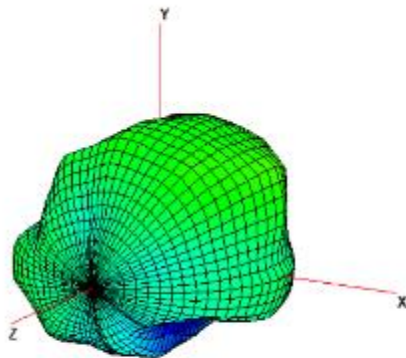

Center Frequency	<b>2110MHz</b>
Horizontal (dBi) peak	-4.05
Vertical (dBi) peak	-2.36

### 2200MHz

Total

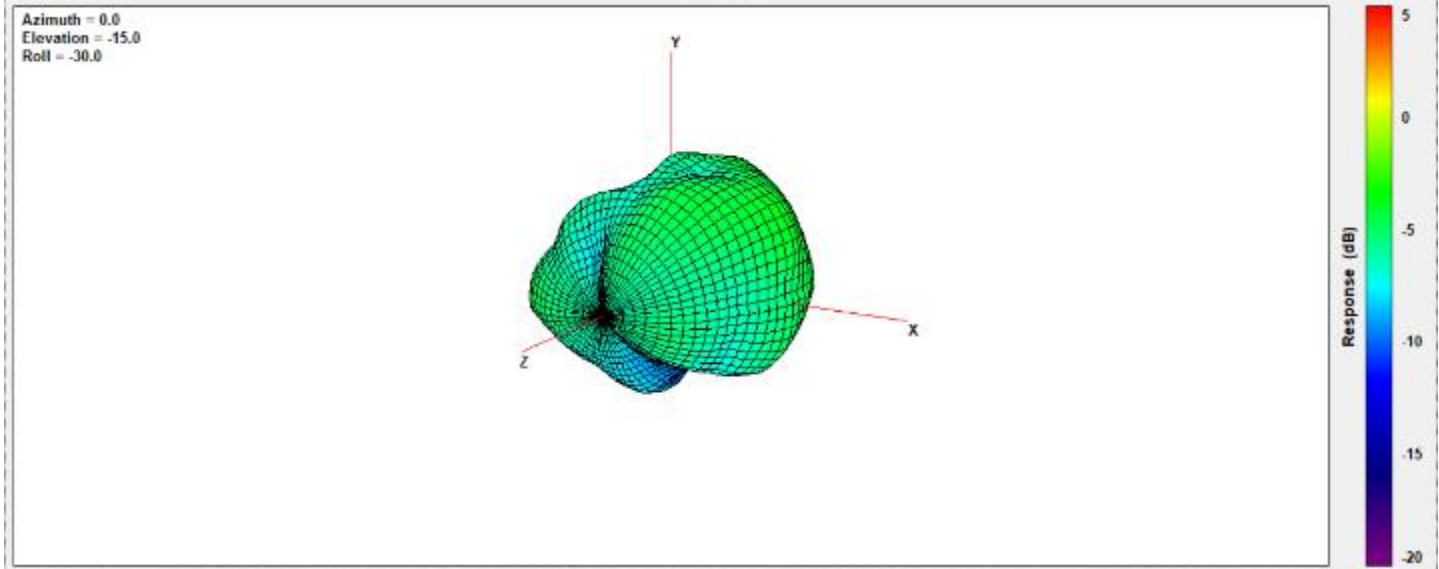

Center Frequency	<b>2200MHz</b>
Horizontal (dBi) peak	-4.86
Vertical (dBi) peak	-3.67

### 2300MHz

Total

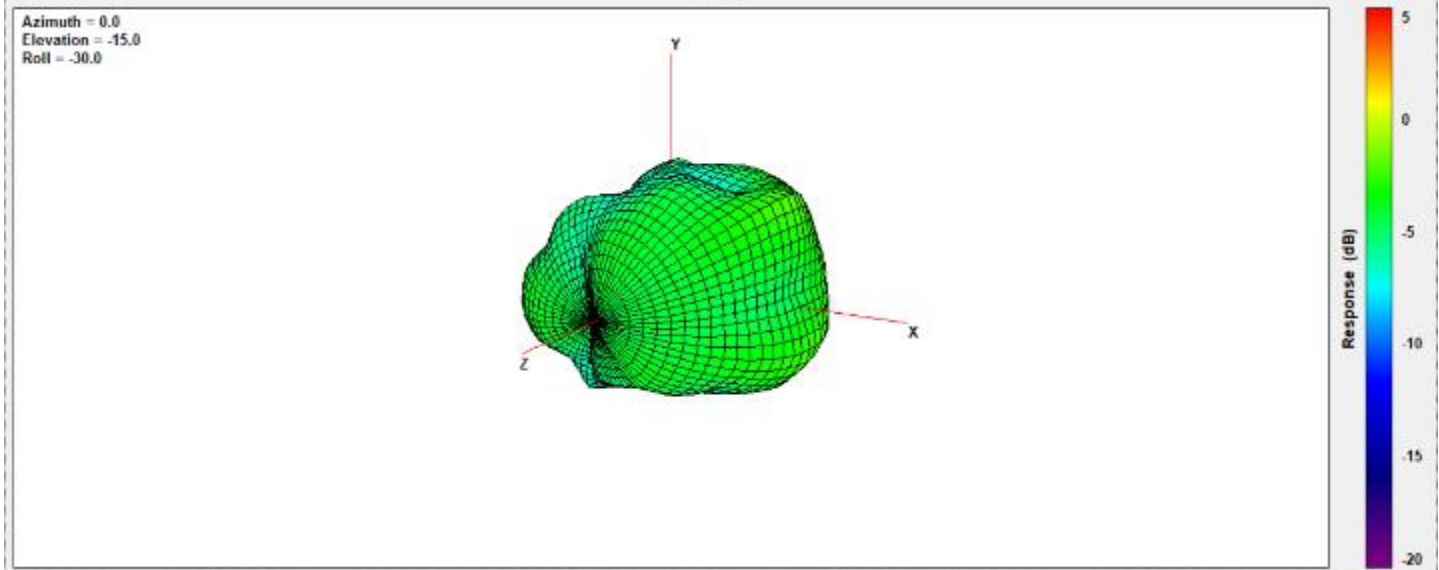

Center Frequency	<b>2300MHz</b>
Horizontal (dBi) peak	-3.19
Vertical (dBi) peak	-1.76



### 2305MHz

Total

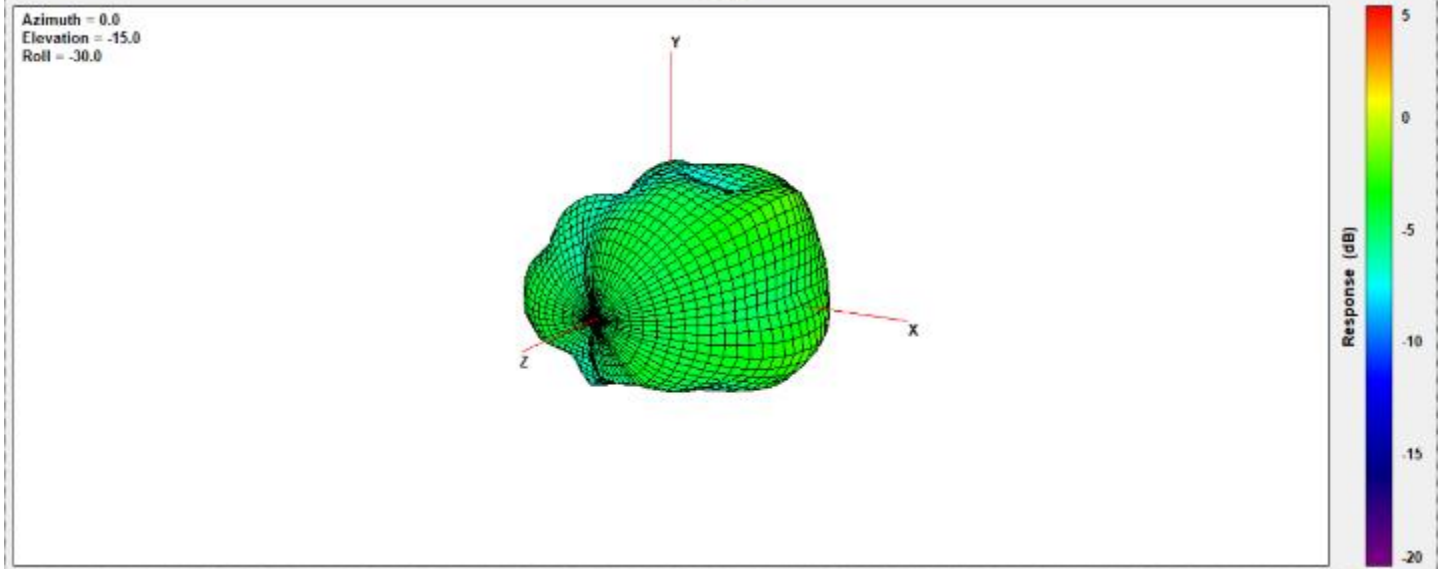

Center Frequency	<b>2305MHz</b>
Horizontal (dBi) peak	-3.26
Vertical (dBi) peak	-1.78

### 2315MHz

Total

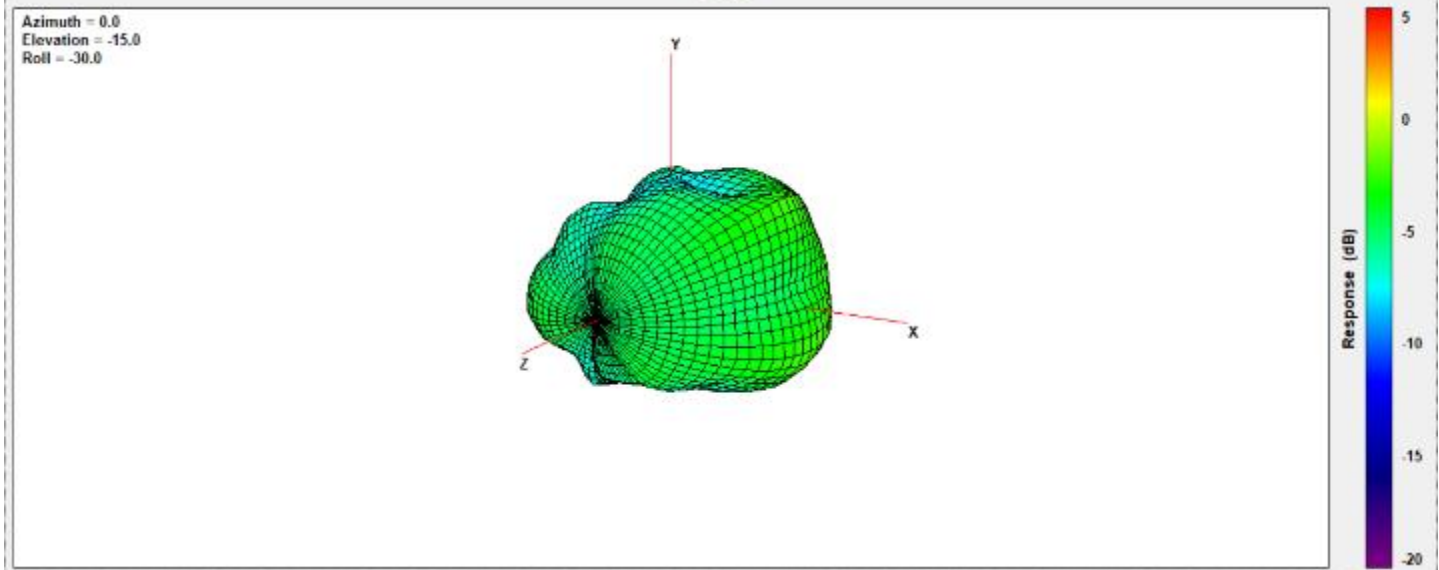

Center Frequency	<b>2315MHz</b>
Horizontal (dBi) peak	-3.51
Vertical (dBi) peak	-1.65

### 2350MHz

Total

Azimuth = 0.0  
Elevation = -15.0  
Roll = -30.0

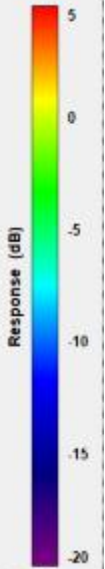
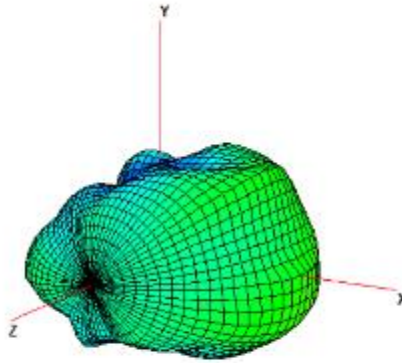

Center Frequency	<b>2350MHz</b>
Horizontal (dBi) peak	-4.31
Vertical (dBi) peak	-1.68

### 2400MHz

Total

Azimuth = 0.0  
Elevation = -15.0  
Roll = -30.0

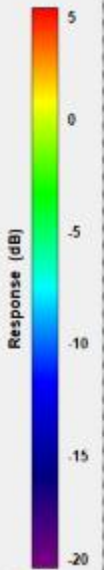
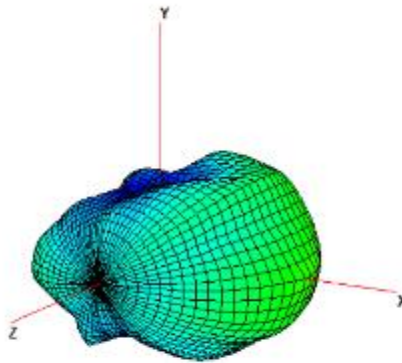

Center Frequency	<b>2400MHz</b>
Horizontal (dBi) peak	-3.76
Vertical (dBi) peak	-2.32

### 2500MHz

Total

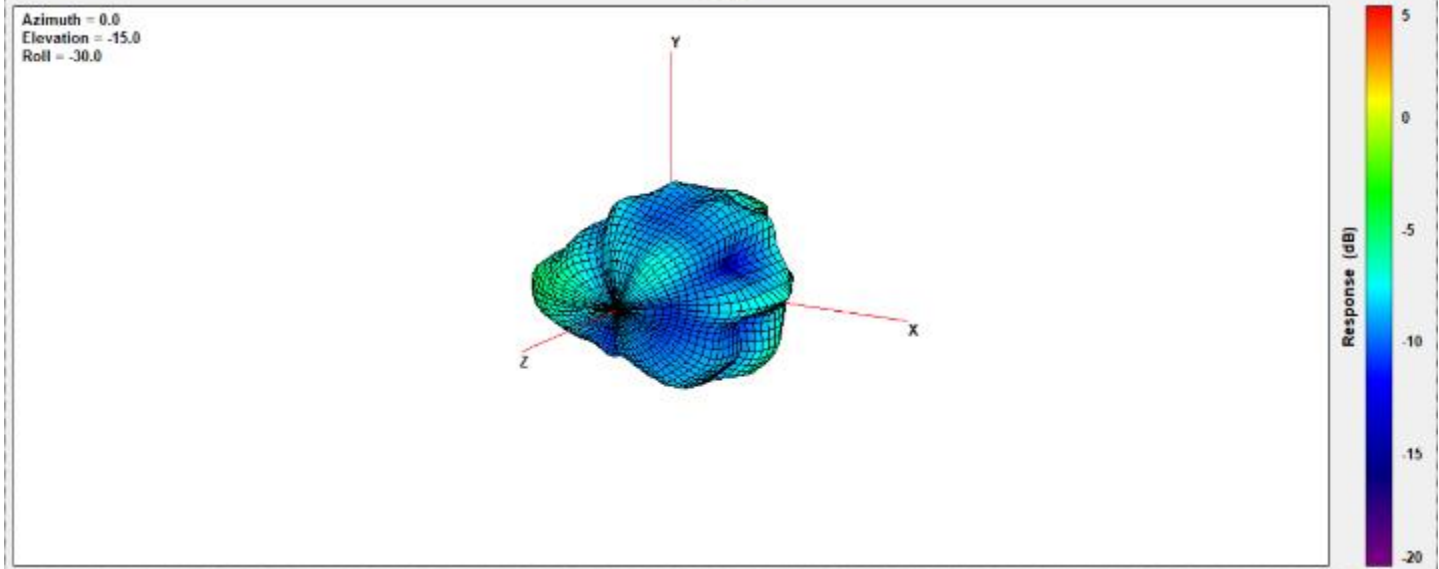

Center Frequency	<b>2500MHz</b>
Horizontal (dBi) peak	-4.85
Vertical (dBi) peak	-4.46

### 2570MHz

Total

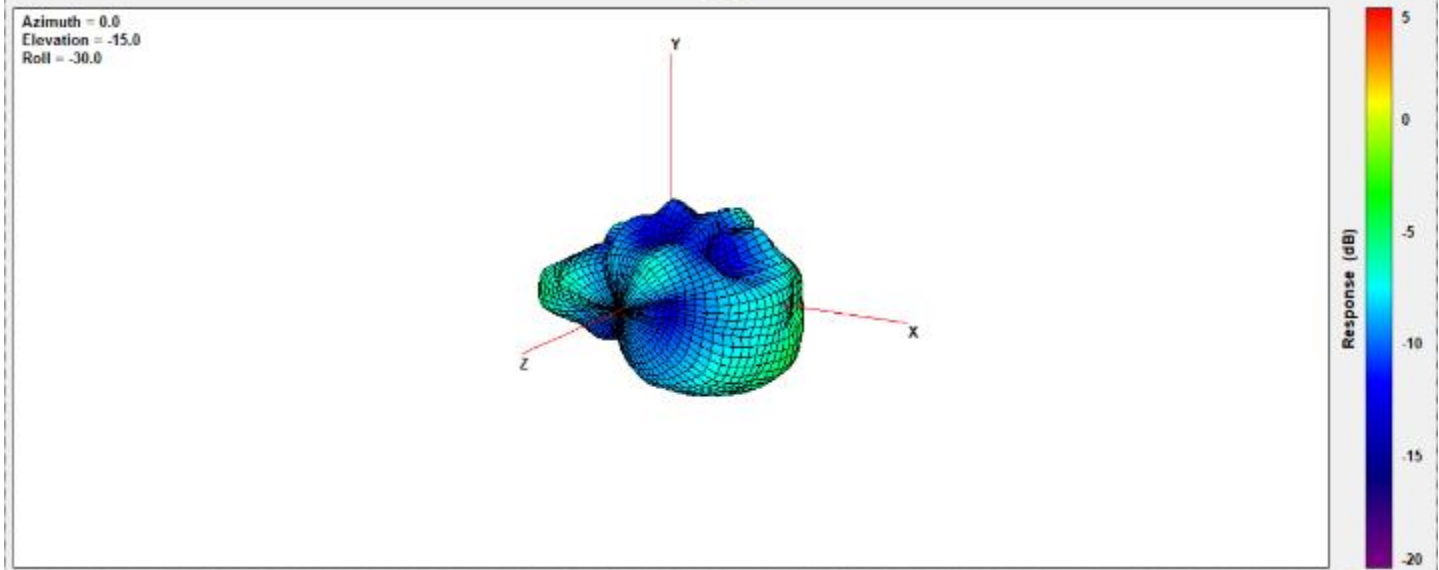

Center Frequency	<b>2570MHz</b>
Horizontal (dBi) peak	-3.51
Vertical (dBi) peak	-2.41

### 2595MHz

Total

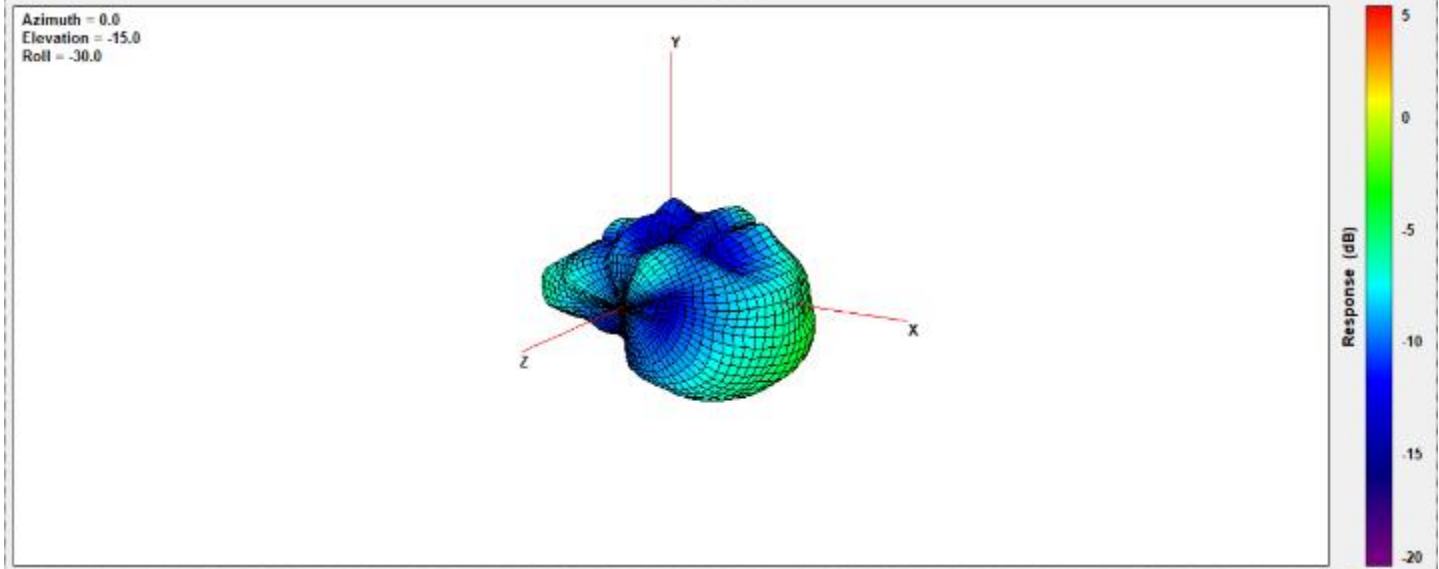

Center Frequency	<b>2595MHz</b>
Horizontal (dBi) peak	-2.78
Vertical (dBi) peak	-1.58

### 2620MHz

Total

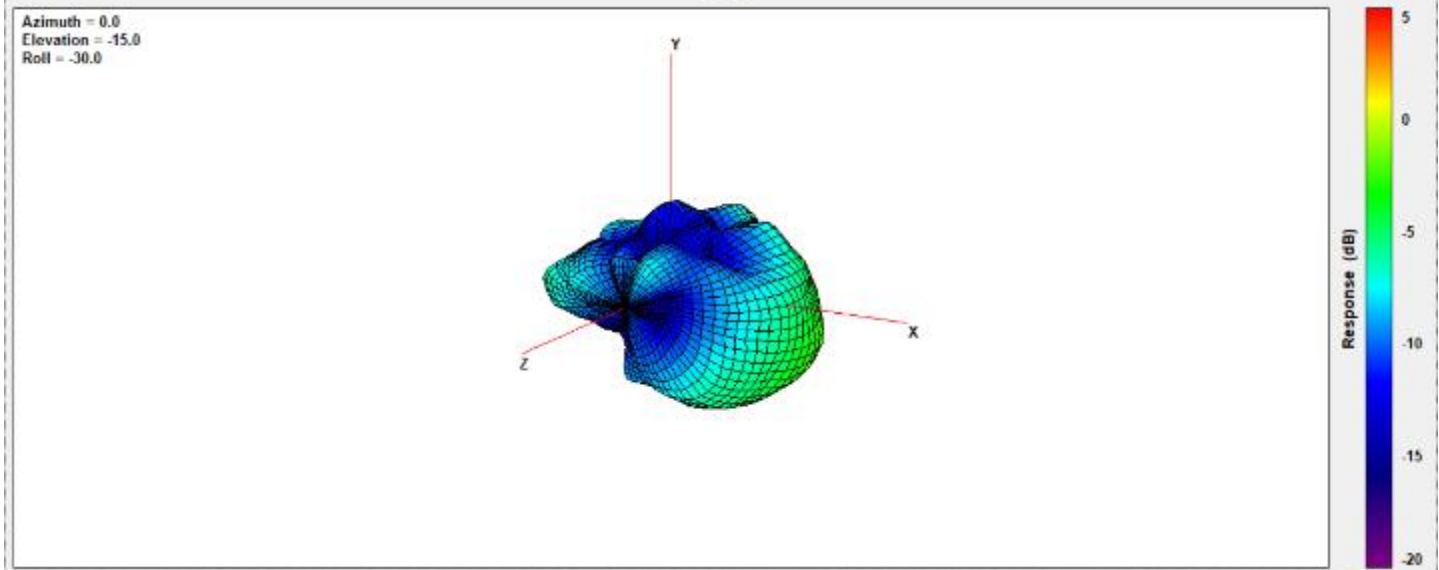

Center Frequency	<b>2620MHz</b>
Horizontal (dBi) peak	-2.13
Vertical (dBi) peak	-0.76

### 2690MHz

Total

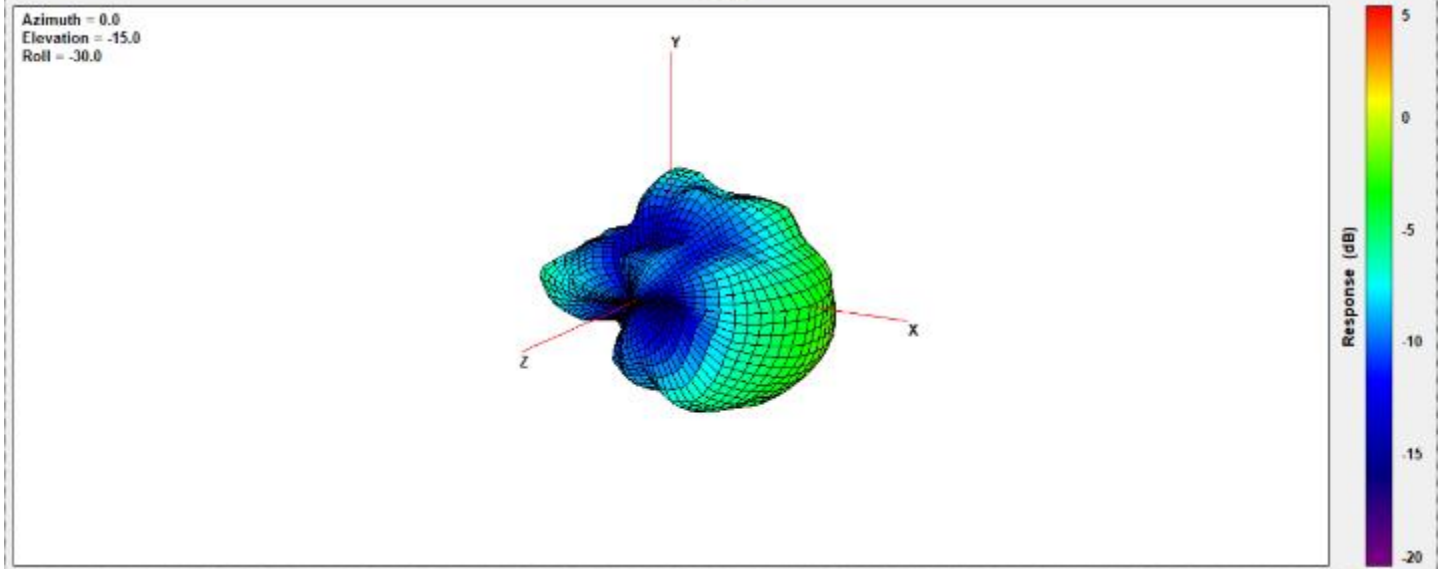

Center Frequency	<b>2690MHz</b>
Horizontal (dBi) peak	-0.82
Vertical (dBi) peak	0.32

### 3400MHz

Total

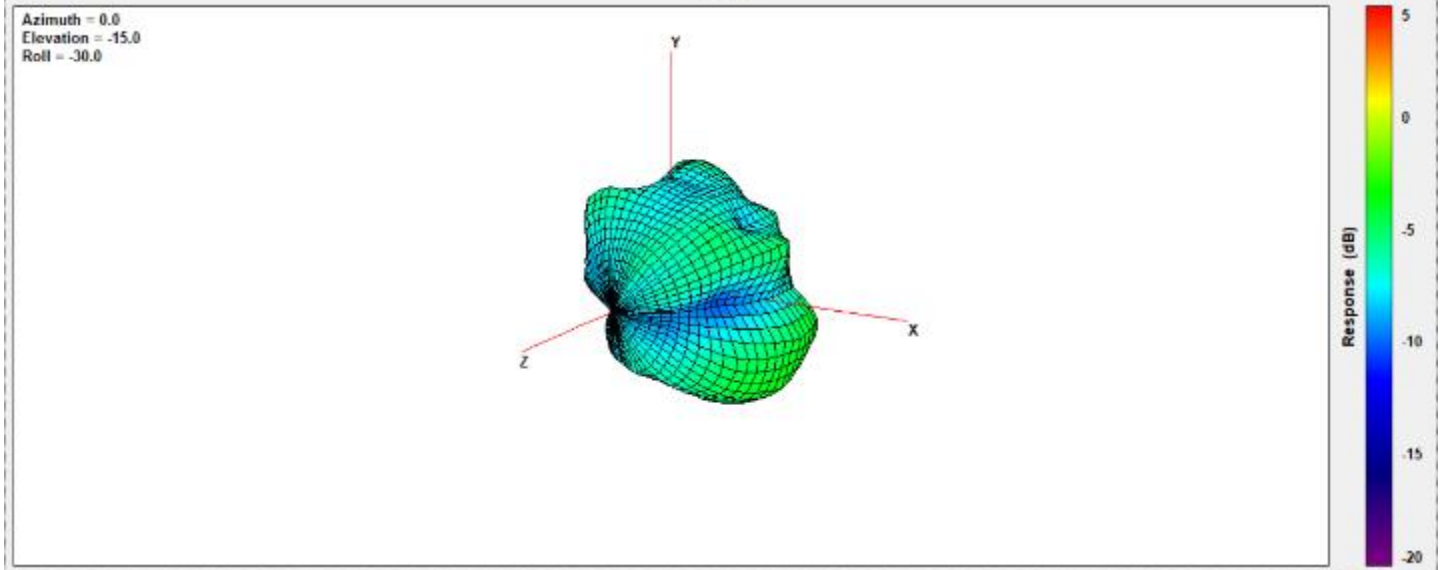

Center Frequency	<b>3400MHz</b>
Horizontal (dBi) peak	-4.98
Vertical (dBi) peak	-3.35

### 3500MHz

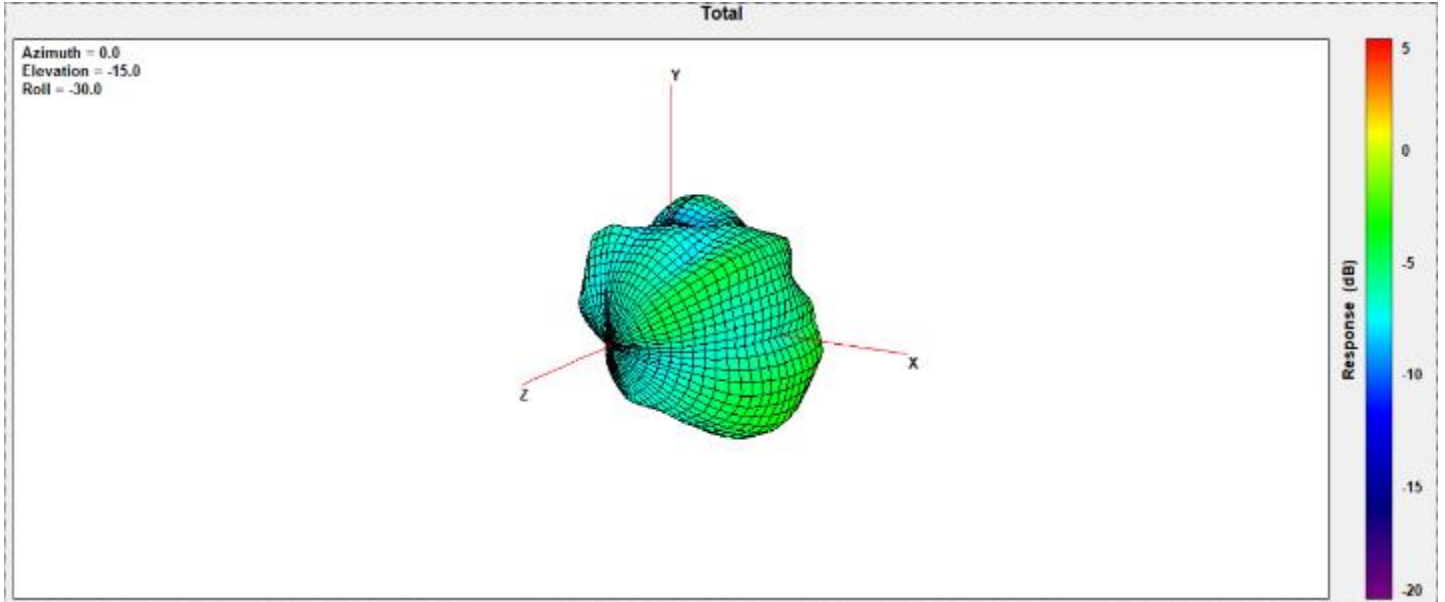

Center Frequency	<b>3500MHz</b>
Horizontal (dBi) peak	-5.00
Vertical (dBi) peak	-3.15

### 3600MHz

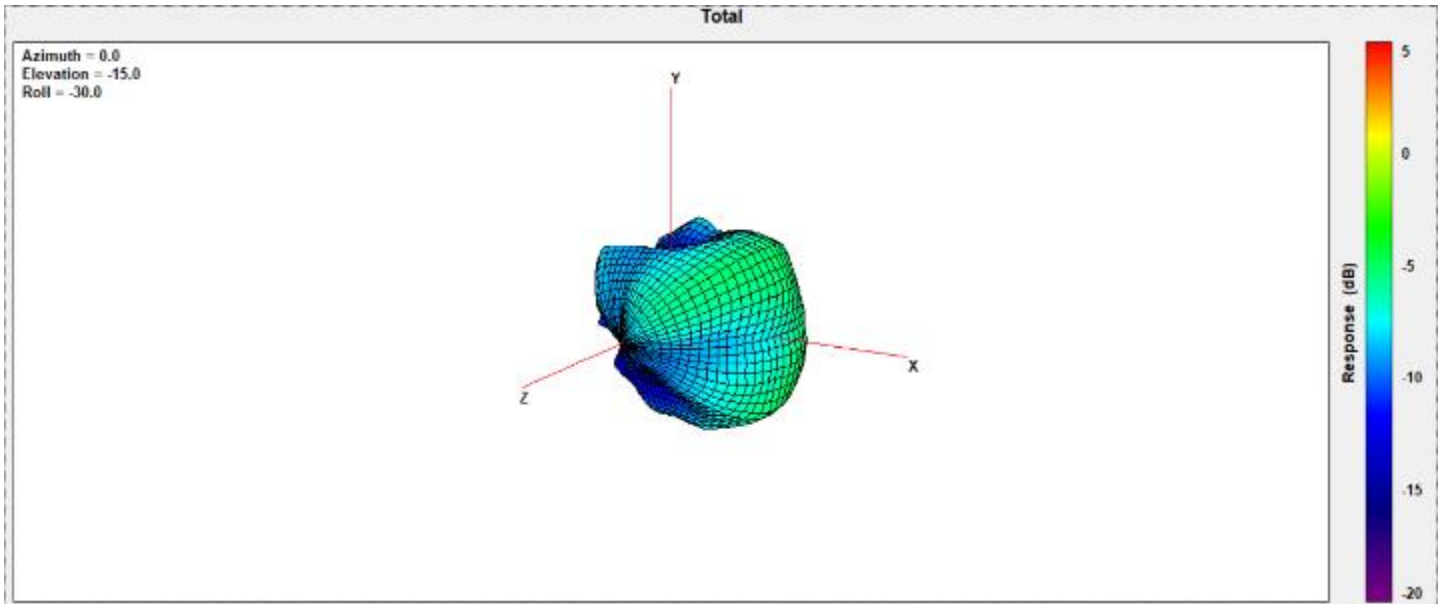

Center Frequency	<b>3600MHz</b>
Horizontal (dBi) peak	-4.90
Vertical (dBi) peak	-5.33

### 3700MHz

Total

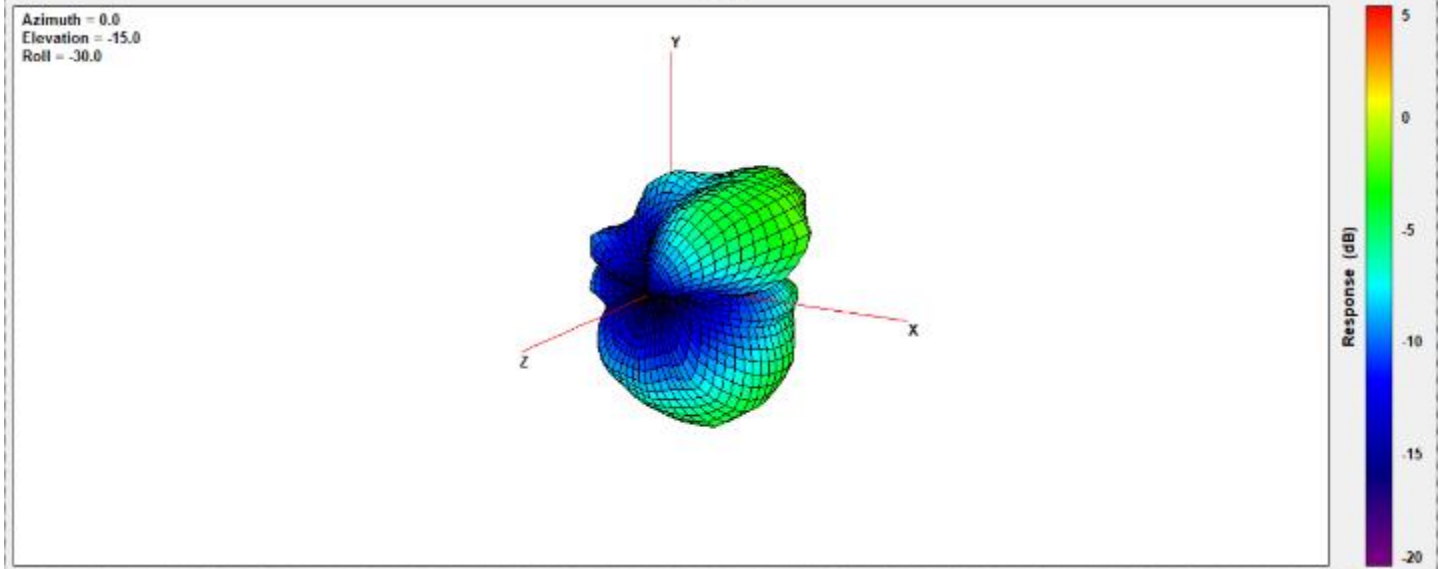

Center Frequency	<b>3700MHz</b>
Horizontal (dBi) peak	-1.61
Vertical (dBi) peak	-2.72

### 3800MHz

Total

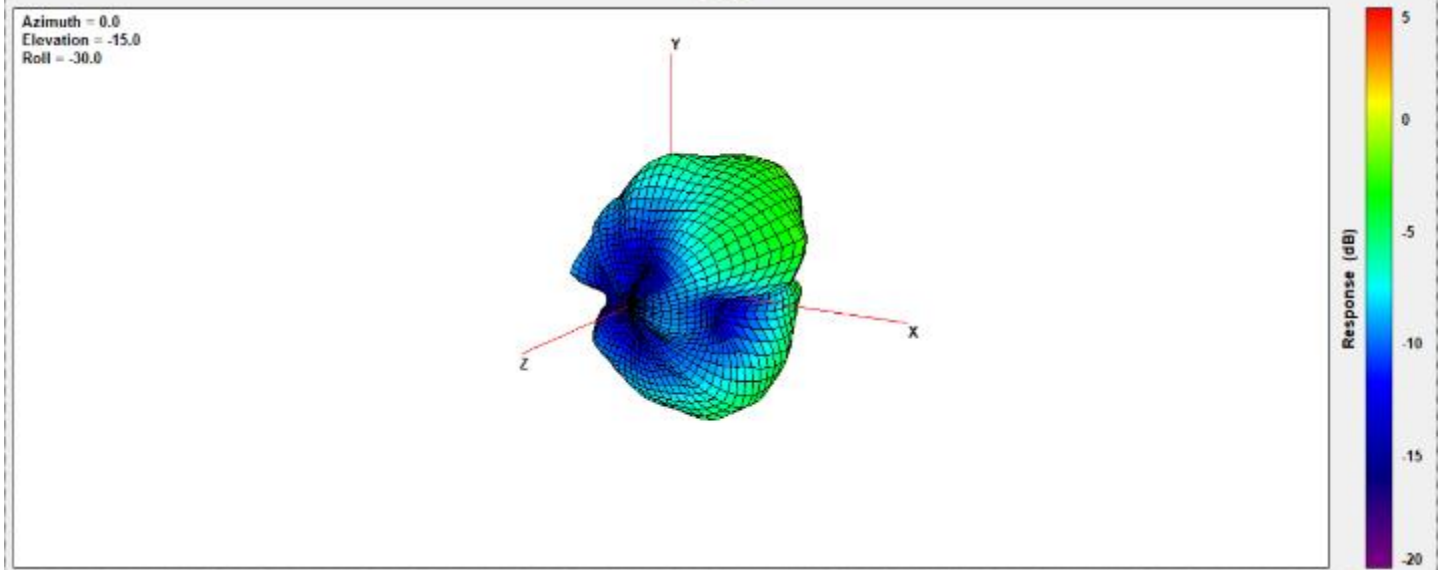

Center Frequency	<b>3800MHz</b>
Horizontal (dBi) peak	-1.68
Vertical (dBi) peak	-1.48

### 4200MHz

Total

Azimuth = 0.0  
Elevation = -15.0  
Roll = -30.0

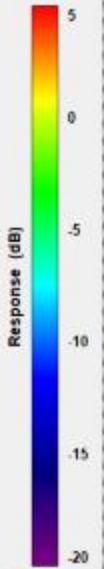
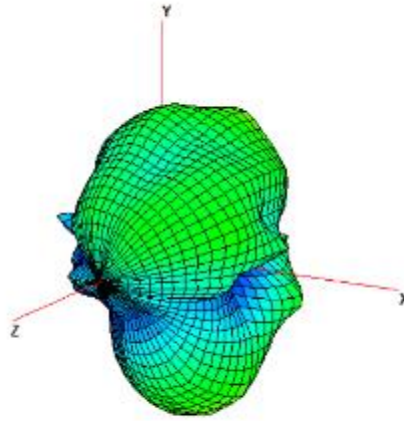

Center Frequency	<b>4200MHz</b>
Horizontal (dBi) peak	-1.56
Vertical (dBi) peak	-2.77

### 4400MHz

Total

Azimuth = 0.0  
Elevation = -15.0  
Roll = -30.0

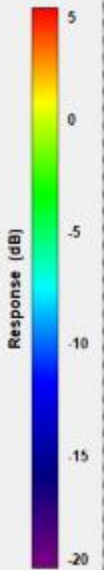
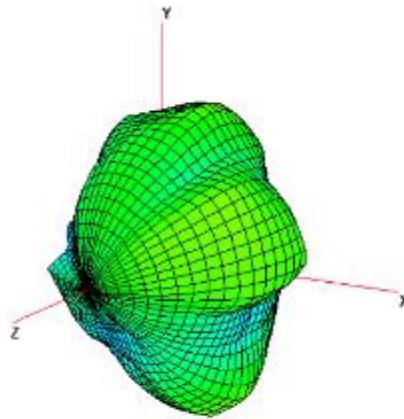

Center Frequency	<b>4400MHz</b>
Horizontal (dBi) peak	-1.62
Vertical (dBi) peak	-2.75



### 4700MHz

Total

Azimuth = 0.0  
Elevation = -15.0  
Roll = -30.0

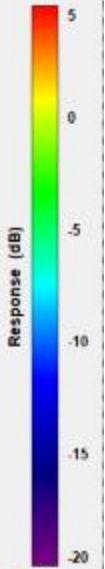
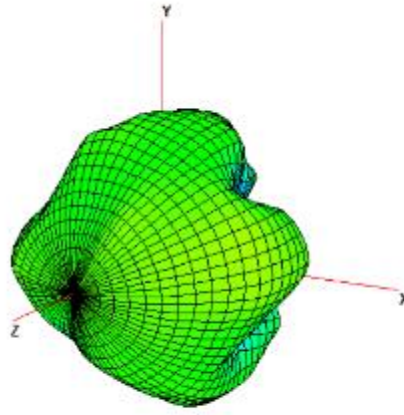

Center Frequency	<b>4700MHz</b>
Horizontal (dBi) peak	-0.65
Vertical (dBi) peak	-2.80

### 5150MHz

Total

Azimuth = 0.0  
Elevation = -15.0  
Roll = -30.0

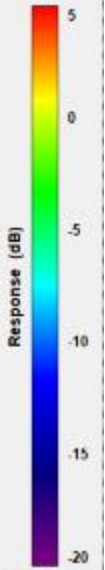
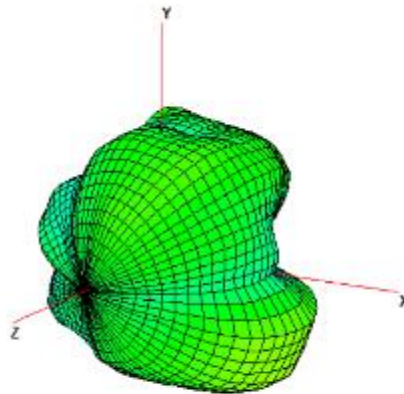

Center Frequency	<b>5150MHz</b>
Horizontal (dBi) peak	-0.02
Vertical (dBi) peak	-2.44

**5537.5MHz**

Total

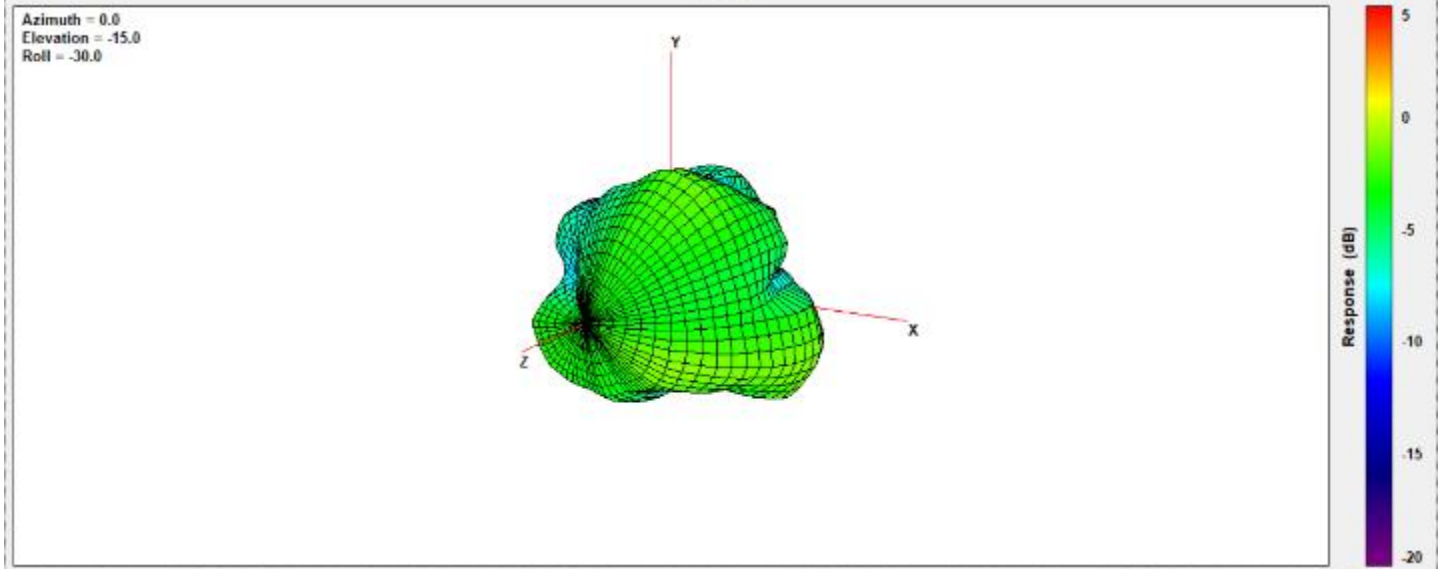

Center Frequency	<b>5537.5MHz</b>
Horizontal (dBi) peak	-1.07
Vertical (dBi) peak	-4.05

**5925MHz**

Total

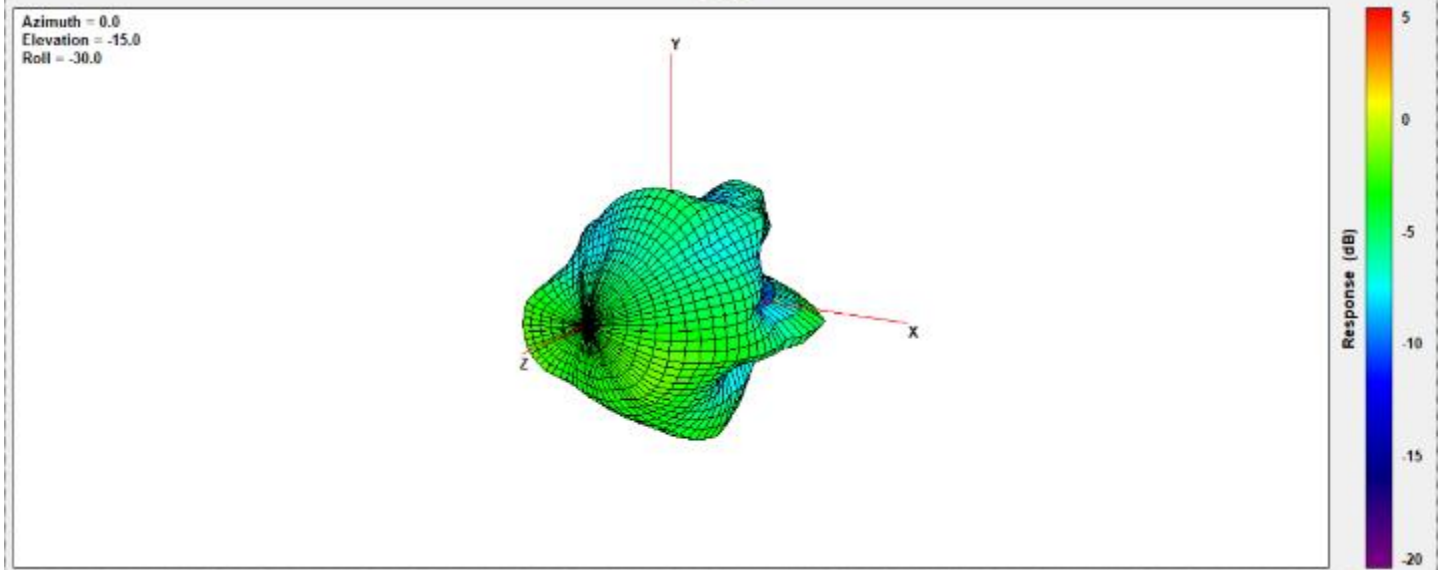

Center Frequency	<b>5925MHz</b>
Horizontal (dBi) peak	-2.04
Vertical (dBi) peak	-2.73

# MIMO2 Antenna (DRx2)

## 1710 MHz

Total

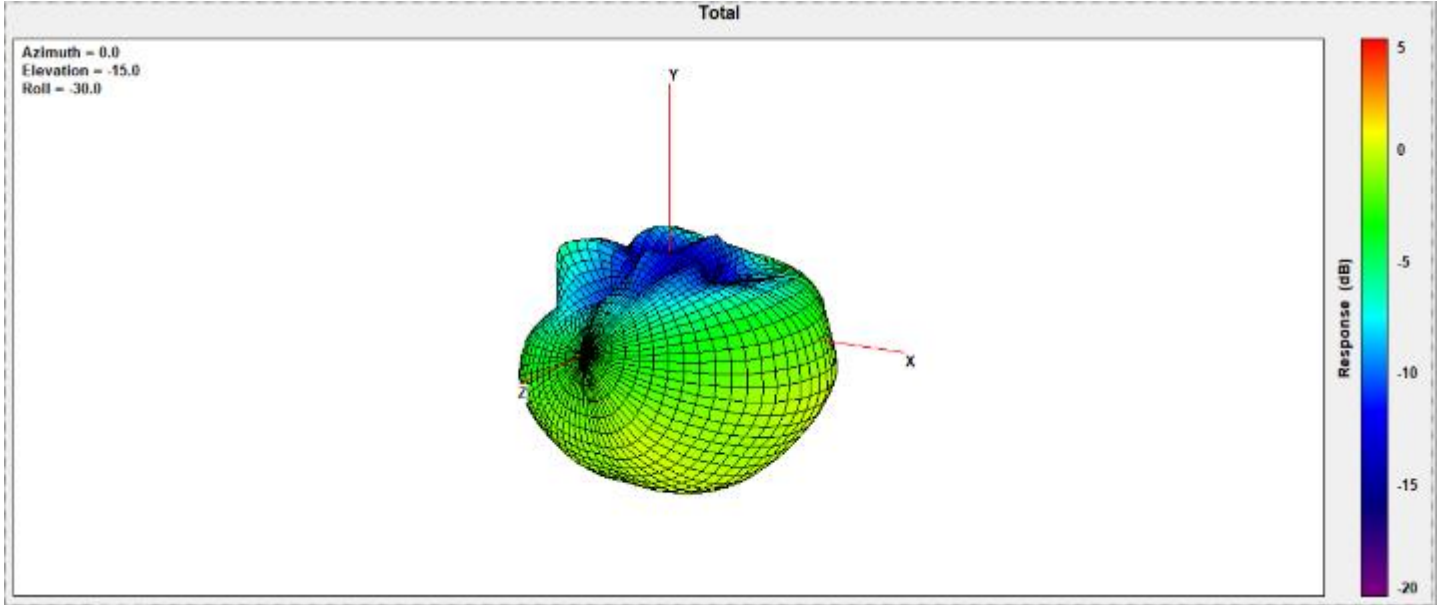

Center Frequency	<b>1710 MHz</b>
Horizontal (dBi) peak	0.33
Vertical (dBi) peak	0.59

## 1732.5 MHz

Total

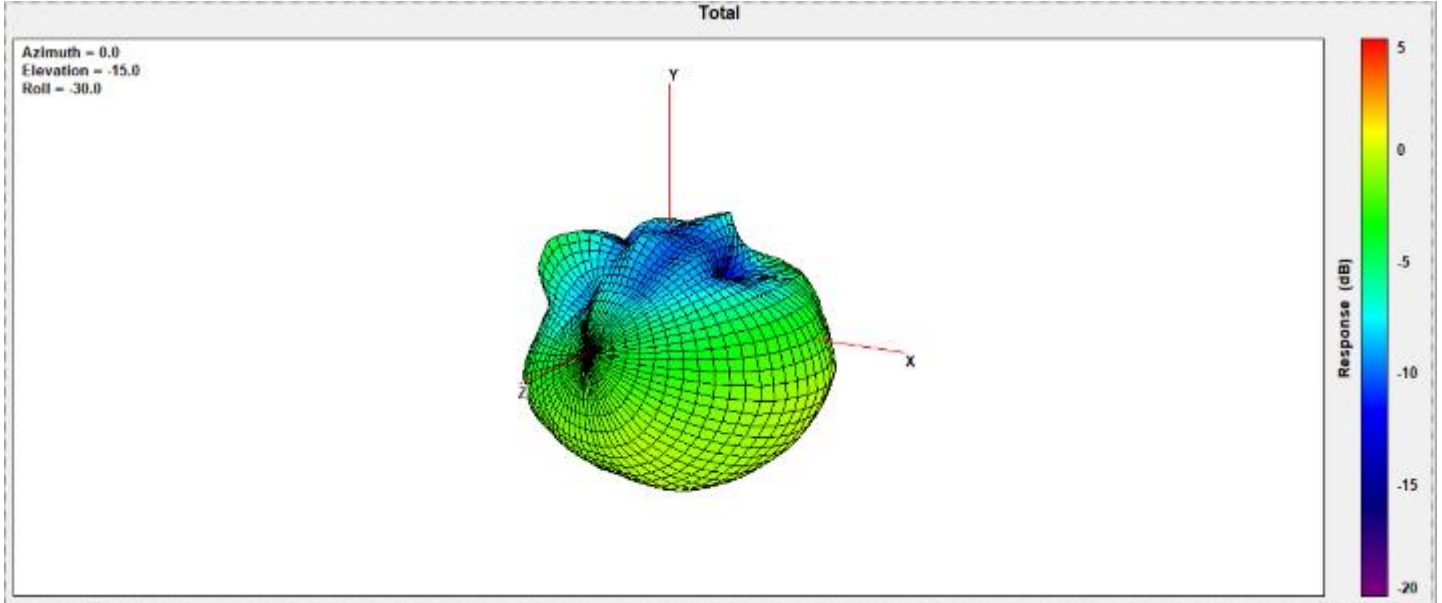

Center Frequency	<b>1732.5 MHz</b>
Horizontal (dBi) peak	-0.07
Vertical (dBi) peak	0.24

**1747.5 MHz**

Total

Azimuth = 0.0  
Elevation = -15.0  
Roll = -30.0

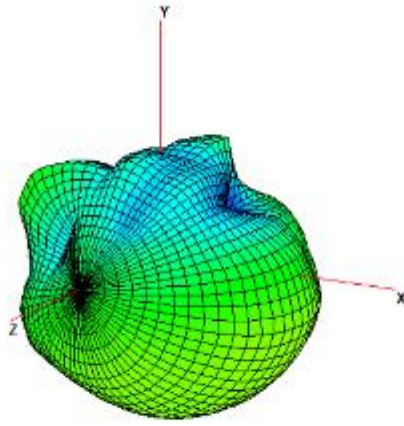

Center Frequency	<b>1747.5 MHz</b>
Horizontal (dBi) peak	-0.76
Vertical (dBi) peak	-0.22

**1755 MHz**

Total

Azimuth = 0.0  
Elevation = -15.0  
Roll = -30.0

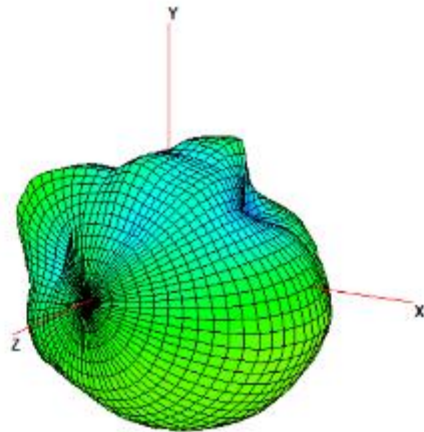

Center Frequency	<b>1755 MHz</b>
Horizontal (dBi) peak	-1.29
Vertical (dBi) peak	-0.58

### 1785 MHz

Total

Azimuth = 0.0  
Elevation = -15.0  
Roll = -30.0

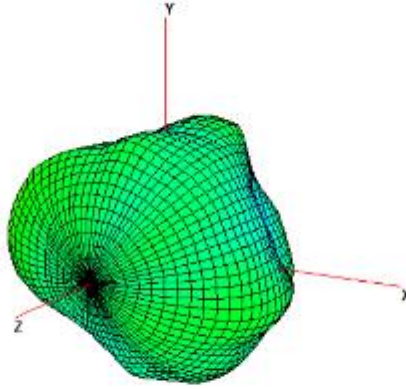

Center Frequency	<b>1785 MHz</b>
Horizontal (dBi) peak	-2.19
Vertical (dBi) peak	-3.92

### 1805 MHz

Total

Azimuth = 0.0  
Elevation = -15.0  
Roll = -30.0

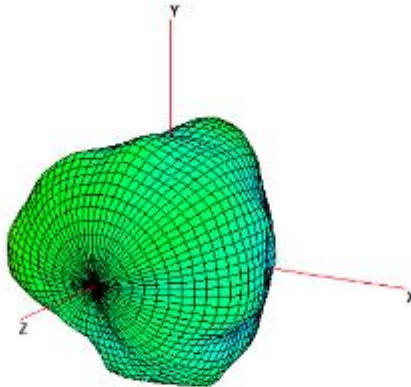

Center Frequency	<b>1805 MHz</b>
Horizontal (dBi) peak	-1.95
Vertical (dBi) peak	-4.45

### 1850 MHz

Total

Azimuth = 0.0  
Elevation = -15.0  
Roll = -30.0

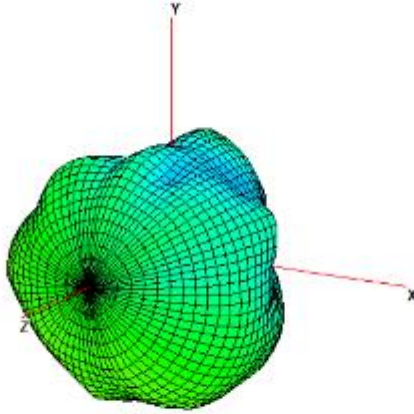

Center Frequency	<b>1850 MHz</b>
Horizontal (dBi) peak	-2.23
Vertical (dBi) peak	-2.20

### 1880 MHz

Total

Azimuth = 0.0  
Elevation = -15.0  
Roll = -30.0

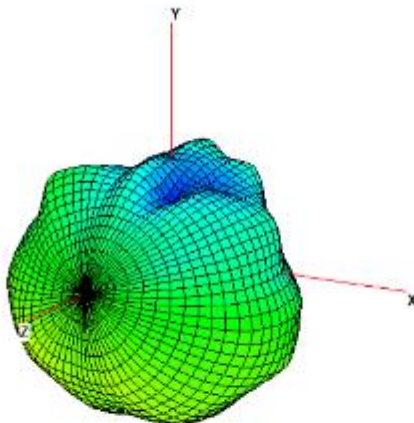

Center Frequency	<b>1880 MHz</b>
Horizontal (dBi) peak	-0.48
Vertical (dBi) peak	-0.85

### 1910MHz

Total

Azimuth = 0.0  
Elevation = -15.0  
Roll = -30.0

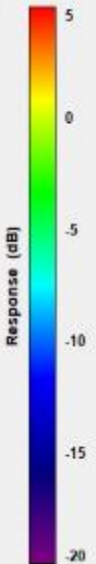
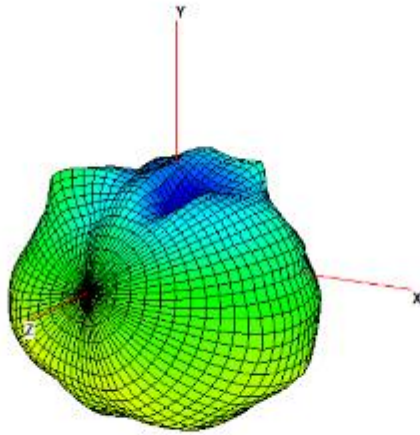

Center Frequency	<b>1910MHz</b>
Horizontal (dBi) peak	0.26
Vertical (dBi) peak	-0.13

### 1920MHz

Total

Azimuth = 0.0  
Elevation = -15.0  
Roll = -30.0

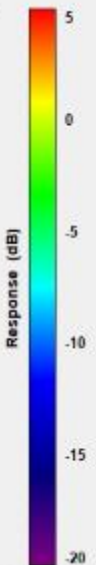
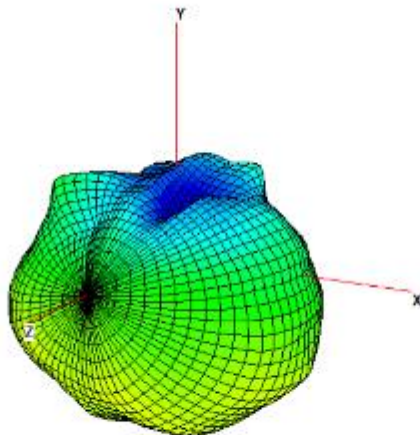

Center Frequency	<b>1920MHz</b>
Horizontal (dBi) peak	0.04
Vertical (dBi) peak	-0.01

### 1950MHz

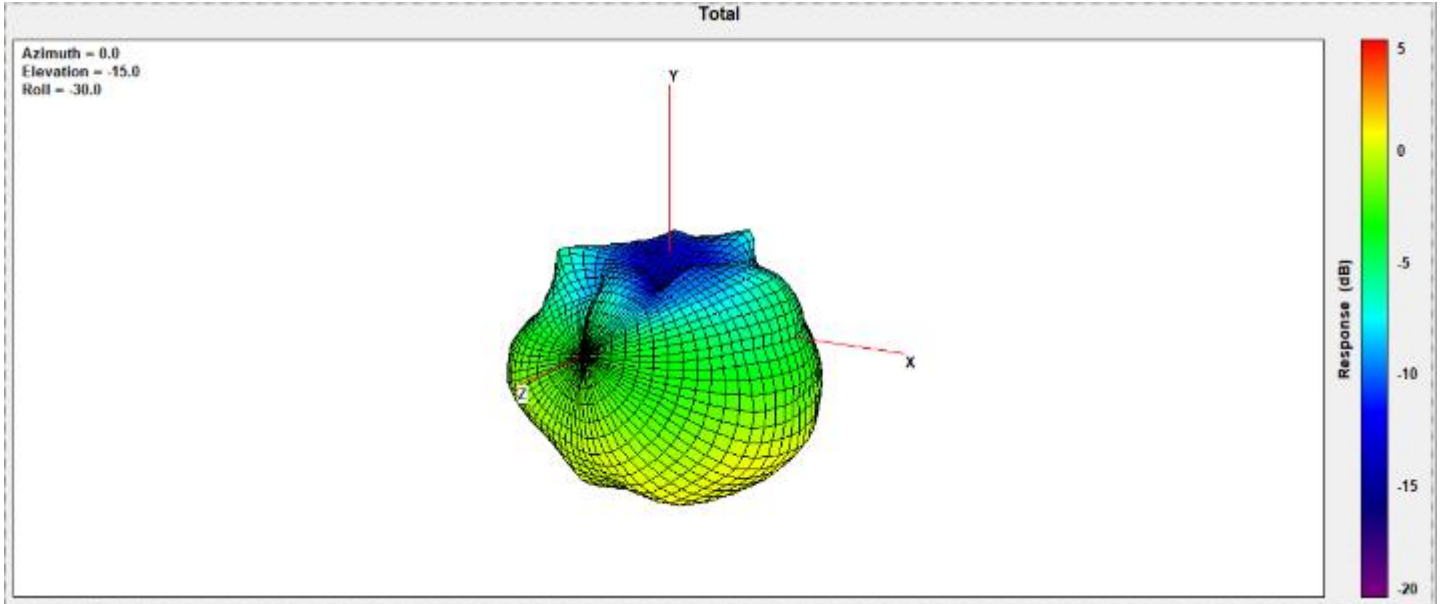

Center Frequency	<b>1950MHz</b>
Horizontal (dBi) peak	0.14
Vertical (dBi) peak	0.79

### 1980MHz

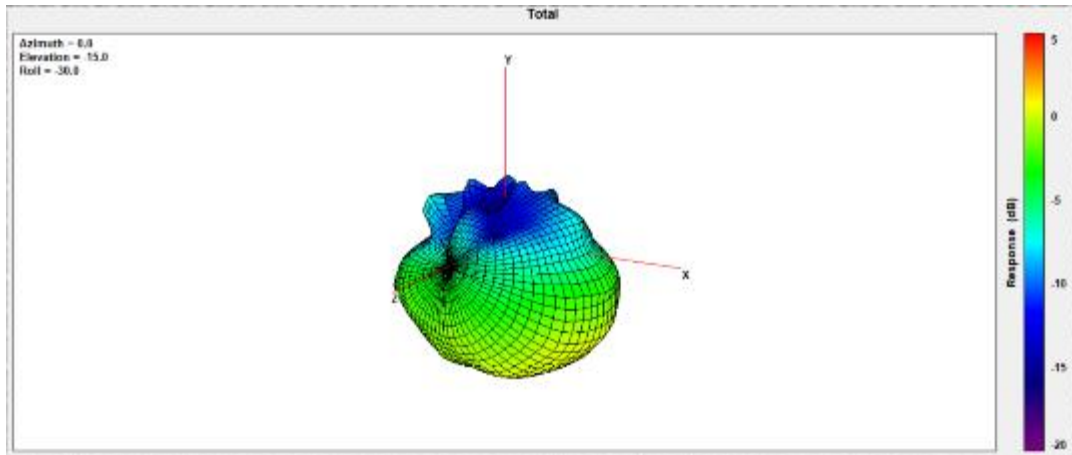

Center Frequency	<b>1980MHz</b>
Horizontal (dBi) peak	-0.78
Vertical (dBi) peak	0.62



### 2110MHz

Total

Azimuth = 0.0  
Elevation = -15.0  
Roll = -30.0

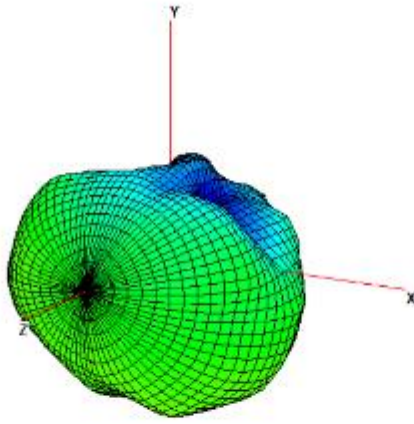

Center Frequency	<b>2110MHz</b>
Horizontal (dBi) peak	-2.22
Vertical (dBi) peak	-1.60

### 2200MHz

Total

Azimuth = 0.0  
Elevation = -15.0  
Roll = -30.0

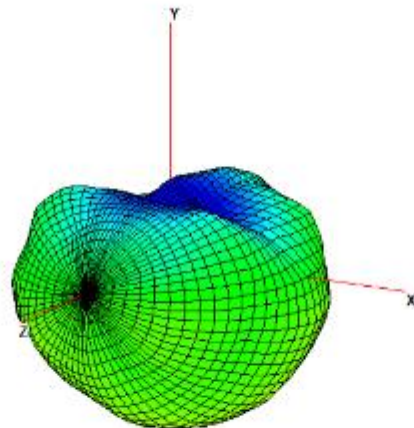

Center Frequency	<b>2200MHz</b>
Horizontal (dBi) peak	-0.30
Vertical (dBi) peak	-0.49

### 2300MHz

Total

Azimuth = 0.0  
Elevation = -15.0  
Roll = -30.0

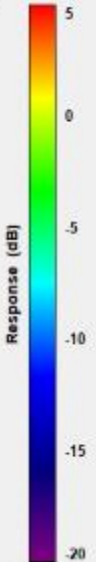
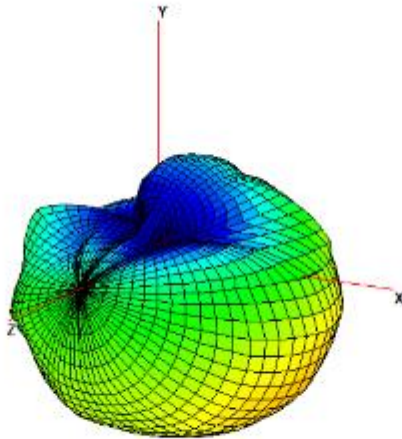

Center Frequency	<b>2300MHz</b>
Horizontal (dBi) peak	1.10
Vertical (dBi) peak	0.12

### 2305MHz

Total

Azimuth = 0.0  
Elevation = -15.0  
Roll = -30.0

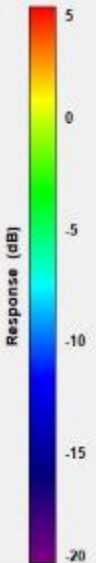
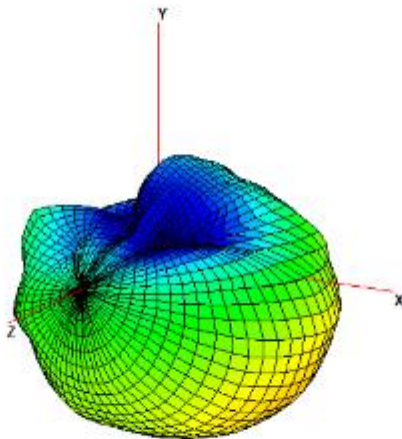

Center Frequency	<b>2305MHz</b>
Horizontal (dBi) peak	0.89
Vertical (dBi) peak	0.99

### 2315MHz

Total

Azimuth = 0.0  
Elevation = -15.0  
Roll = -30.0

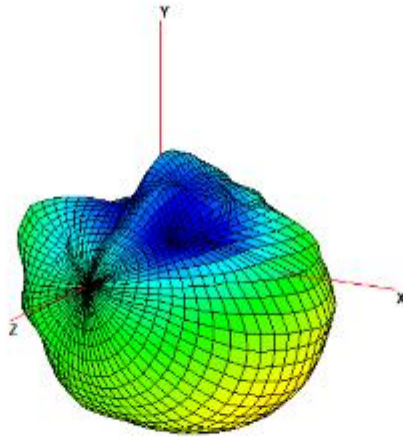

Center Frequency	<b>2315MHz</b>
Horizontal (dBi) peak	0.26
Vertical (dBi) peak	0.49

### 2350MHz

Total

Azimuth = 0.0  
Elevation = -15.0  
Roll = -30.0

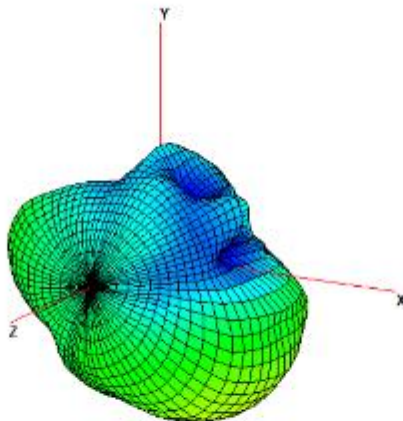

Center Frequency	<b>2350MHz</b>
Horizontal (dBi) peak	-0.12
Vertical (dBi) peak	-0.54

### 2400MHz

Total

Azimuth = 0.0  
Elevation = -15.0  
Roll = -30.0

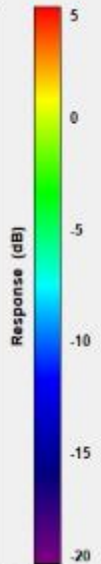
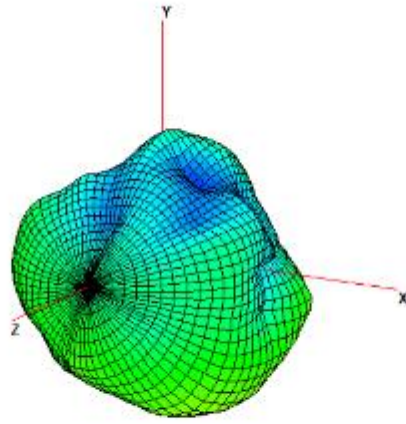

Center Frequency	<b>2400MHz</b>
Horizontal (dBi) peak	-1.50
Vertical (dBi) peak	-1.48

### 2500MHz

Total

Azimuth = 0.0  
Elevation = -15.0  
Roll = -30.0

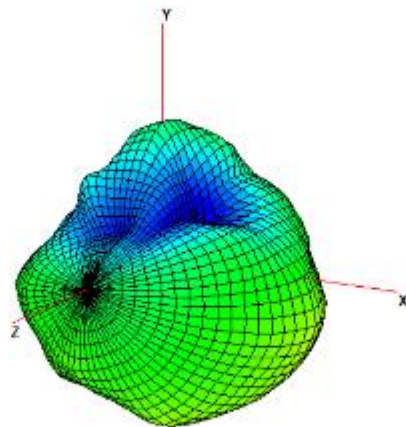

Center Frequency	<b>2500MHz</b>
Horizontal (dBi) peak	-0.97
Vertical (dBi) peak	0.39

### 2570MHz

Total

Azimuth = 0.0  
Elevation = -15.0  
Roll = -30.0

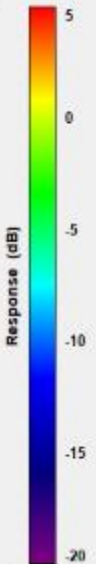
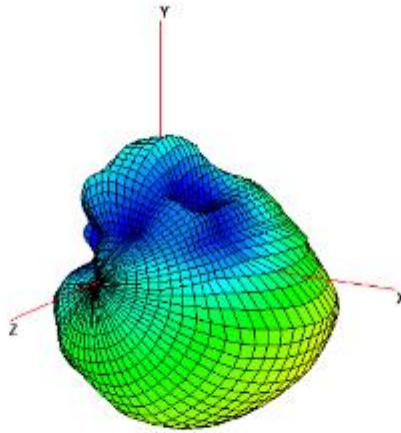

Center Frequency	<b>2570MHz</b>
Horizontal (dBi) peak	1.40
Vertical (dBi) peak	1.80

### 2595MHz

Total

Azimuth = 0.0  
Elevation = -15.0  
Roll = -30.0

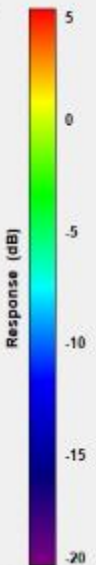
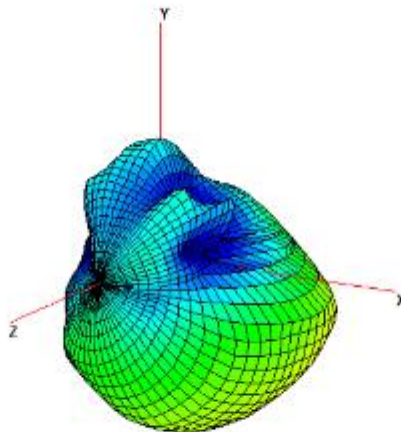

Center Frequency	<b>2595MHz</b>
Horizontal (dBi) peak	0.56
Vertical (dBi) peak	1.85

### 2620MHz

Total

Azimuth = 0.0  
Elevation = -15.0  
Roll = -30.0

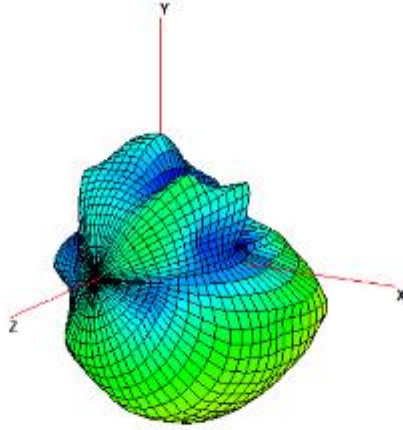

Center Frequency	<b>2620MHz</b>
Horizontal (dBi) peak	-0.97
Vertical (dBi) peak	0.81

### 2690MHz

Total

Azimuth = 0.0  
Elevation = -15.0  
Roll = -30.0

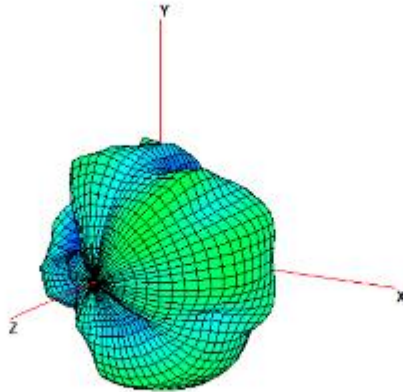

Center Frequency	<b>2690MHz</b>
Horizontal (dBi) peak	-5.26
Vertical (dBi) peak	-2.75

### 3400MHz

Total

Azimuth = 0.0  
Elevation = -15.0  
Roll = -30.0

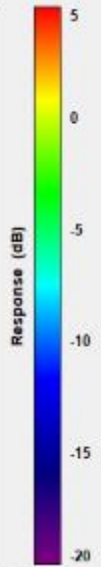
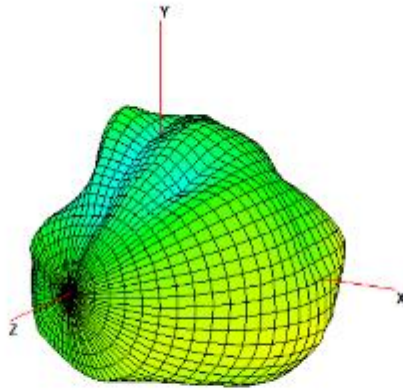

Center Frequency	<b>3400MHz</b>
Horizontal (dBi) peak	-2.90
Vertical (dBi) peak	0.44

### 3500MHz

Total

Azimuth = 0.0  
Elevation = -15.0  
Roll = -30.0

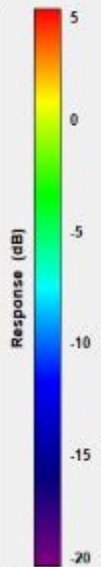
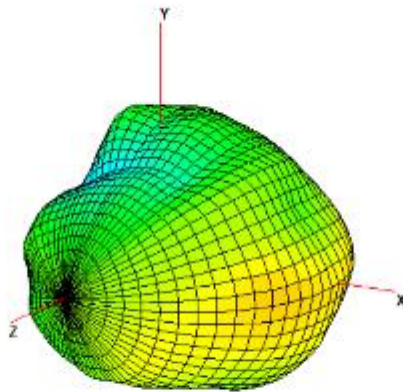

Center Frequency	<b>3500MHz</b>
Horizontal (dBi) peak	-2.42
Vertical (dBi) peak	0.82

### 3600MHz

Total

Azimuth = 0.0  
Elevation = -15.0  
Roll = -30.0

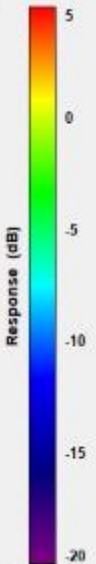
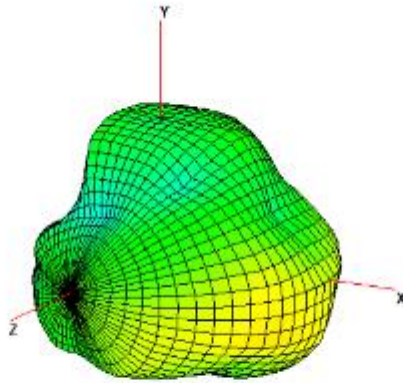

Center Frequency	<b>3600MHz</b>
Horizontal (dBi) peak	-2.01
Vertical (dBi) peak	-0.65

### 3700MHz

Total

Azimuth = 0.0  
Elevation = -15.0  
Roll = -30.0

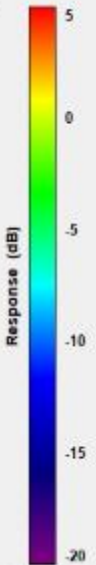
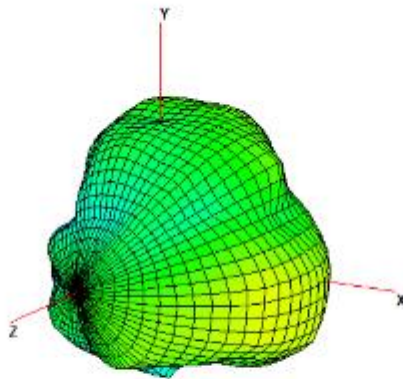

Center Frequency	<b>3700MHz</b>
Horizontal (dBi) peak	-1.54
Vertical (dBi) peak	-0.98



### 3800MHz

Total

Azimuth = 0.0  
Elevation = -15.0  
Roll = -30.0

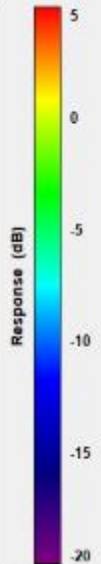
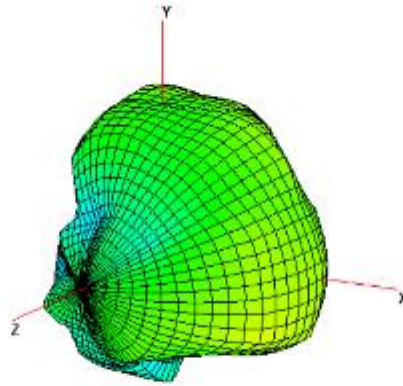

Center Frequency	<b>3800MHz</b>
Horizontal (dBi) peak	-0.11
Vertical (dBi) peak	-1.29

### 4200MHz

Total

Azimuth = 0.0  
Elevation = -15.0  
Roll = -30.0

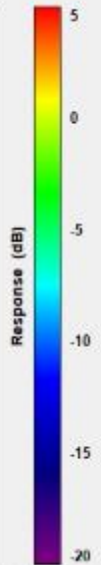
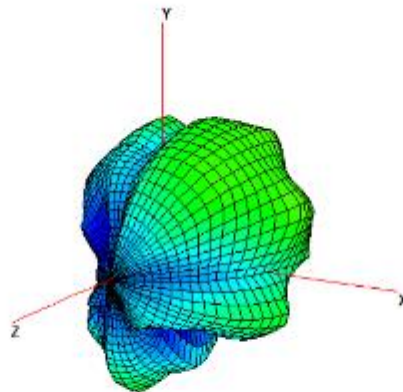

Center Frequency	<b>4200MHz</b>
Horizontal (dBi) peak	-2.42
Vertical (dBi) peak	-4.53

### 4400MHz

Total

Azimuth = 0.0  
Elevation = -15.0  
Roll = -30.0

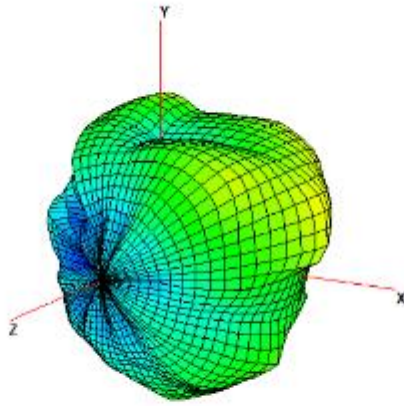

Center Frequency	<b>4400MHz</b>
Horizontal (dBi) peak	-0.32
Vertical (dBi) peak	-2.34

### 4700MHz

Total

Azimuth = 0.0  
Elevation = -15.0  
Roll = -30.0

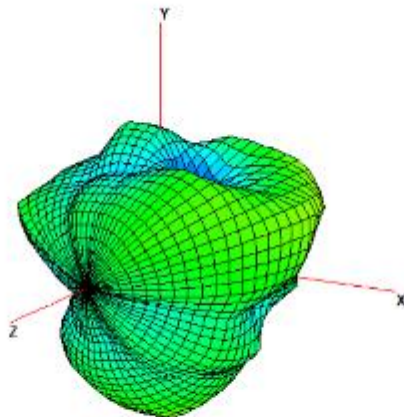

Center Frequency	<b>4700MHz</b>
Horizontal (dBi) peak	-1.07
Vertical (dBi) peak	-0.69

### 5000MHz

Total

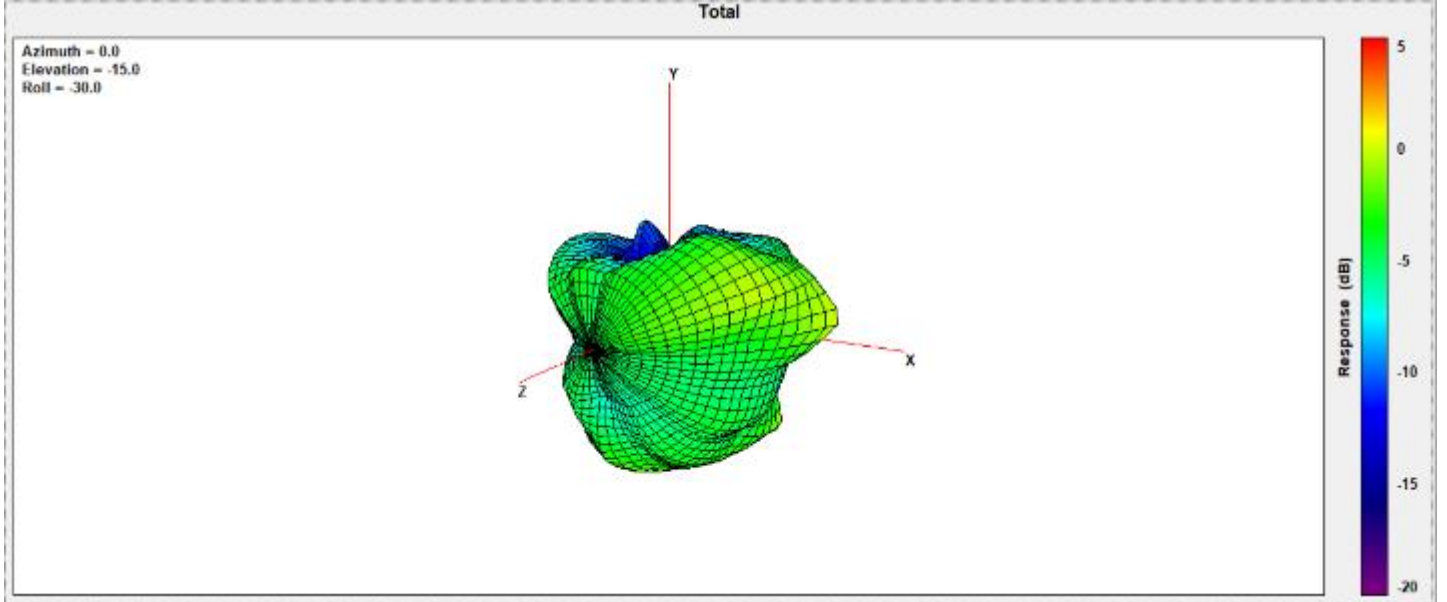

Center Frequency	<b>5000MHz</b>
Horizontal (dBi) peak	-0.08
Vertical (dBi) peak	-1.10



# MIMO3 Antenna (DRx1)

## 1805 MHz

Total

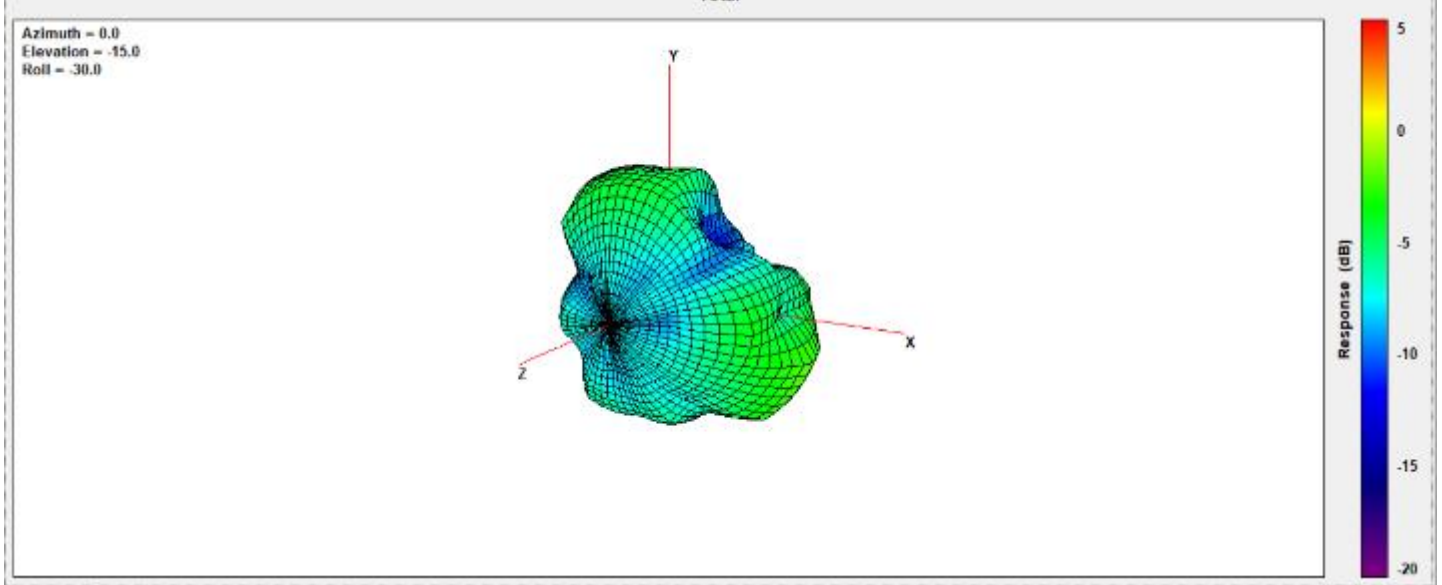

Center Frequency	<b>1805 MHz</b>
Horizontal (dBi) peak	-3.77
Vertical (dBi) peak	-1.85

## 1850 MHz

Total

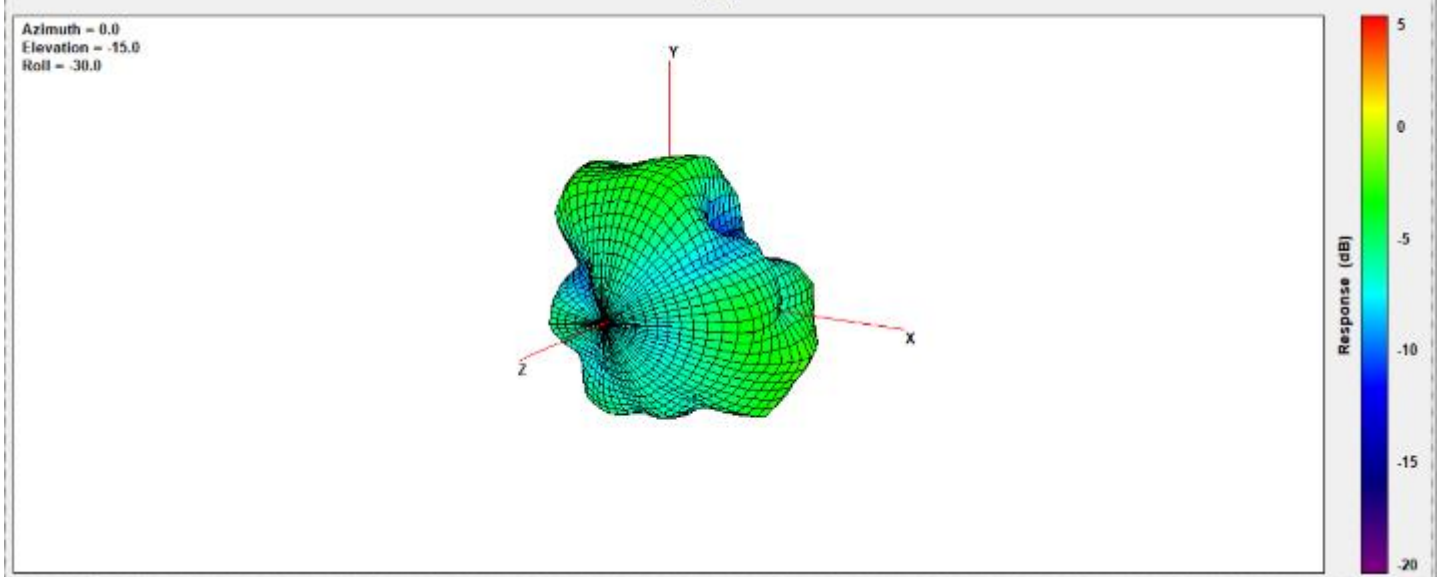

Center Frequency	<b>1850 MHz</b>
Horizontal (dBi) peak	-3.55
Vertical (dBi) peak	-2.08

## 1880 MHz

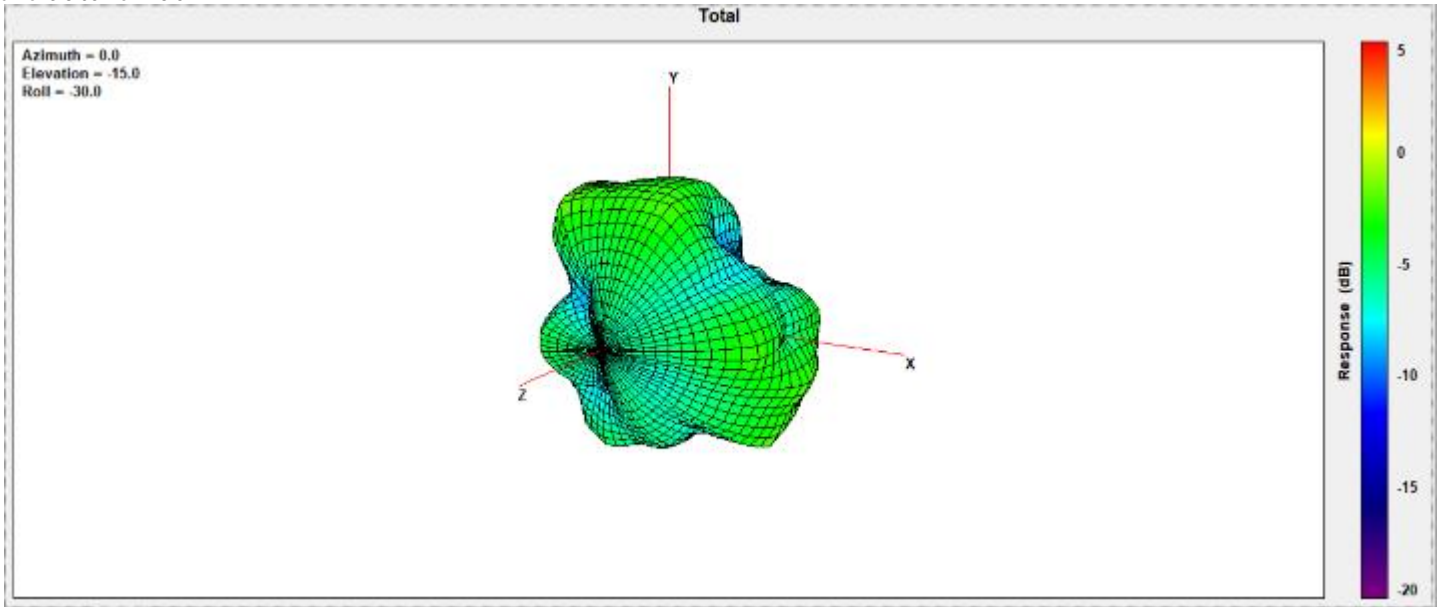

Center Frequency	<b>1880 MHz</b>
Horizontal (dBi) peak	-2.88
Vertical (dBi) peak	-1.93

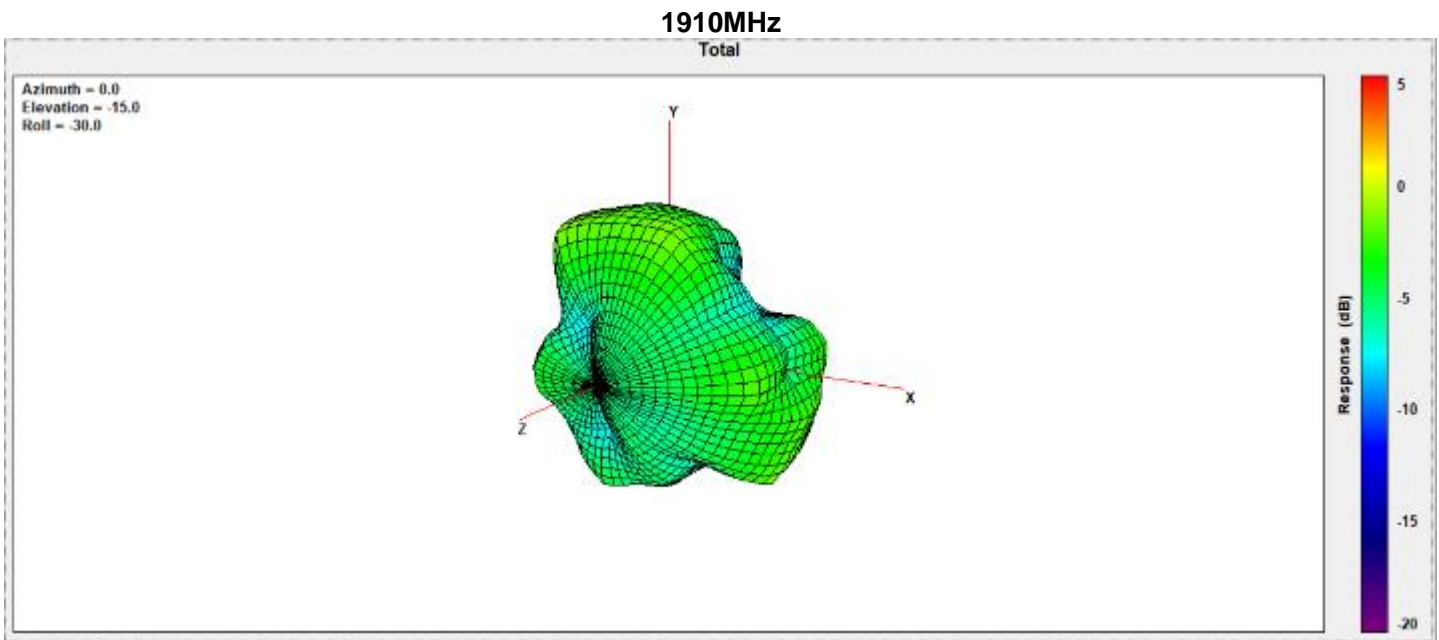

Center Frequency	<b>1910MHz</b>
Horizontal (dBi) peak	-1.70
Vertical (dBi) peak	-1.51

**1920MHz**

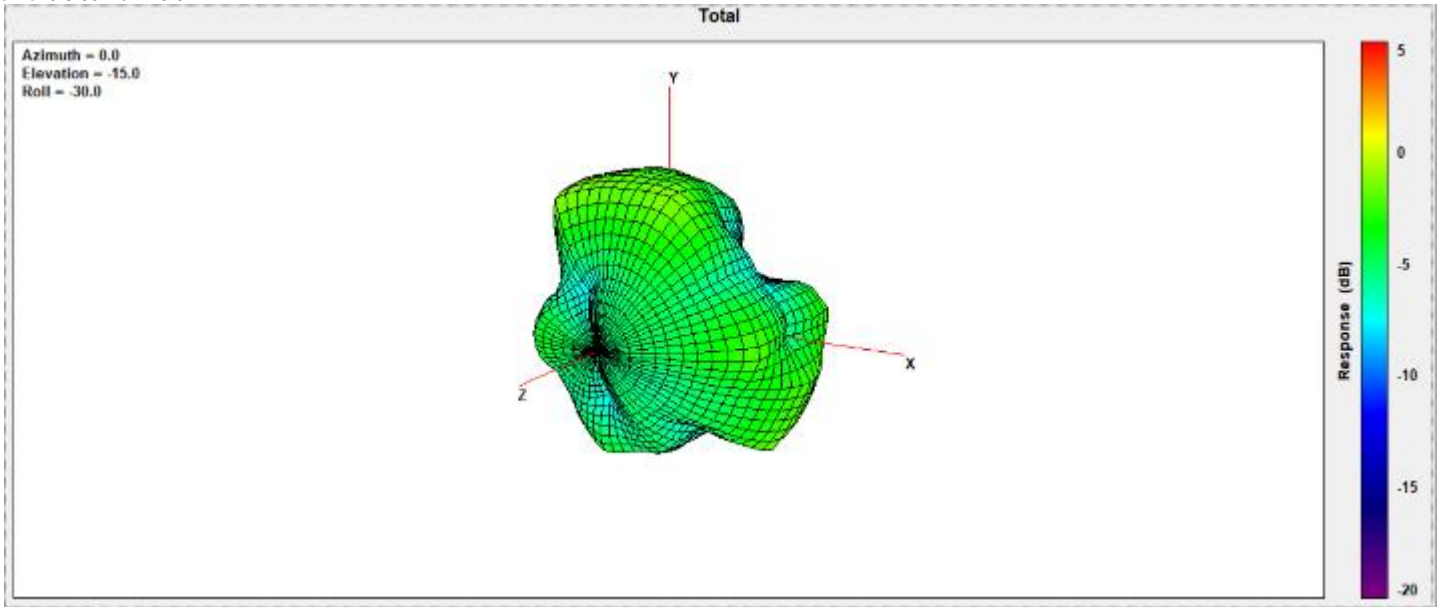

Center Frequency	<b>1920MHz</b>
Horizontal (dBi) peak	-1.52
Vertical (dBi) peak	-1.51

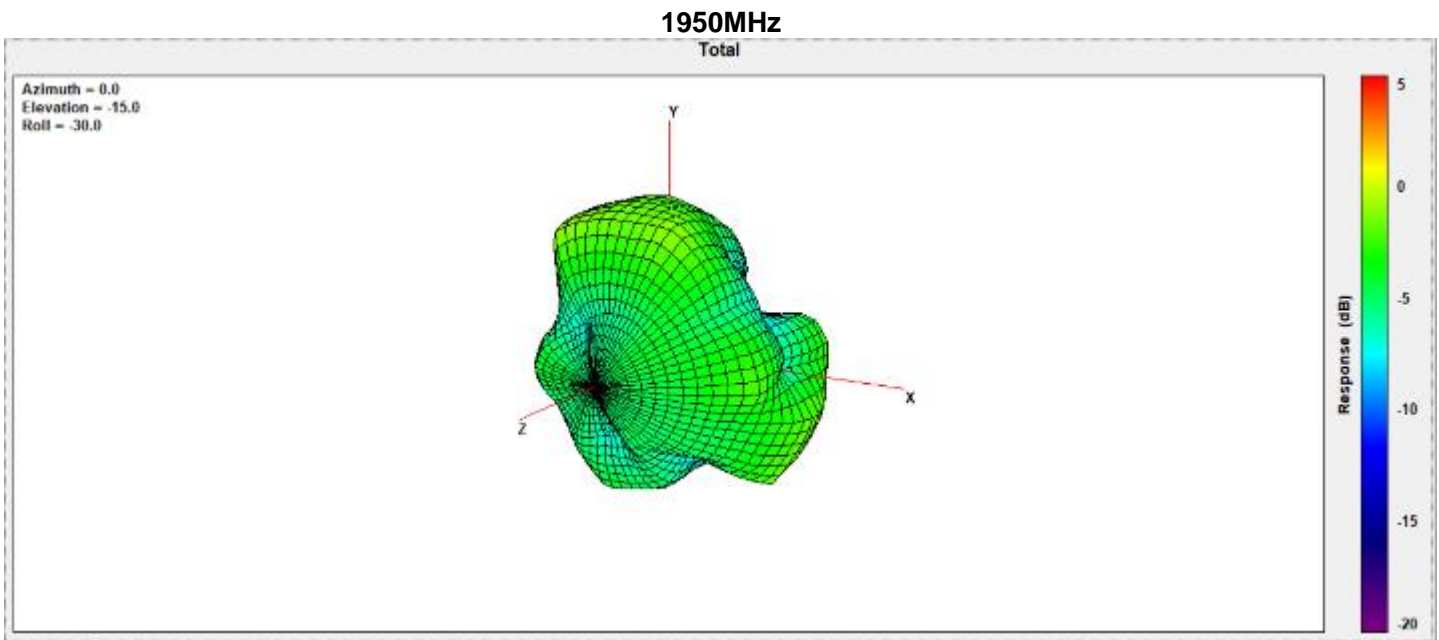

Center Frequency	<b>1950MHz</b>
Horizontal (dBi) peak	-1.19
Vertical (dBi) peak	-1.54

### 1980MHz

Total

Azimuth = 0.0  
Elevation = -15.0  
Roll = -30.0

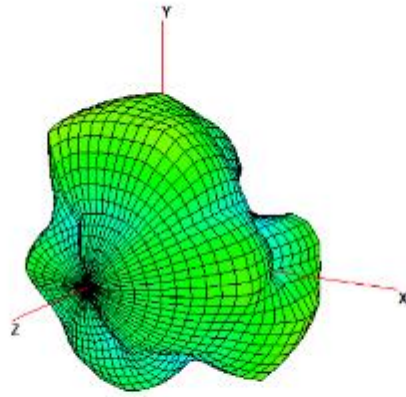

Center Frequency	<b>1980MHz</b>
Horizontal (dBi) peak	-1.27
Vertical (dBi) peak	-1.76

### 2110MHz

Total

Azimuth = 0.0  
Elevation = -15.0  
Roll = -30.0

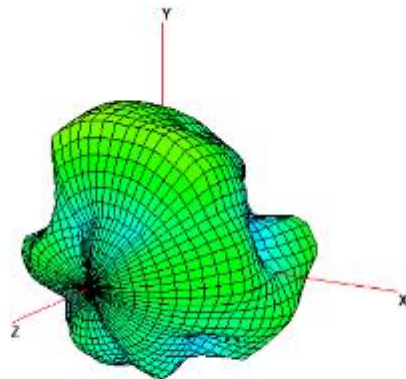

Center Frequency	<b>2110MHz</b>
Horizontal (dBi) peak	-1.41
Vertical (dBi) peak	-2.40

### 2200MHz

Total

Azimuth = 0.0  
Elevation = -15.0  
Roll = -30.0

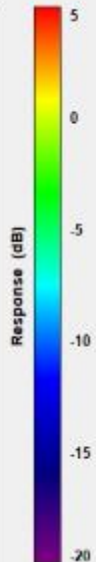
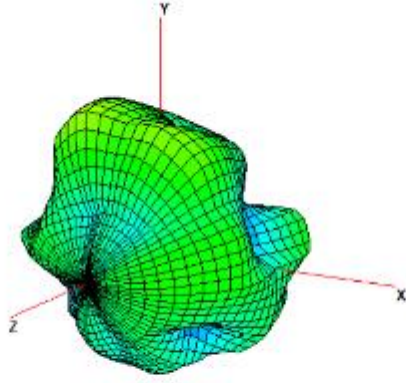

Center Frequency	<b>2200MHz</b>
Horizontal (dBi) peak	-0.89
Vertical (dBi) peak	-2.64

### 2300MHz

Total

Azimuth = 0.0  
Elevation = -15.0  
Roll = -30.0

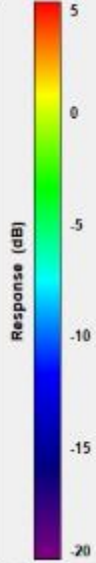
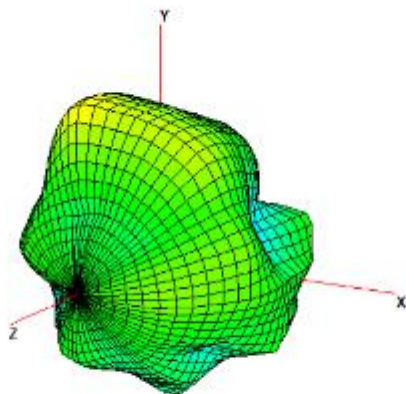

Center Frequency	<b>2300MHz</b>
Horizontal (dBi) peak	0.49
Vertical (dBi) peak	-1.66



### 2305MHz

Total

Azimuth = 0.0  
Elevation = -15.0  
Roll = -30.0

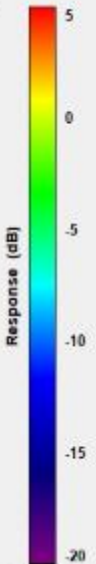
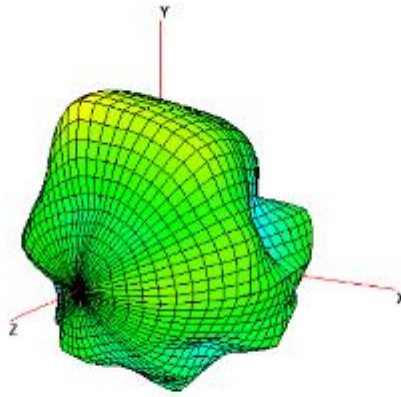

Center Frequency	<b>2305MHz</b>
Horizontal (dBi) peak	0.36
Vertical (dBi) peak	-1.81

### 2315MHz

Total

Azimuth = 0.0  
Elevation = -15.0  
Roll = -30.0

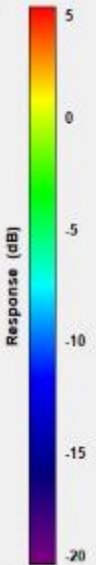
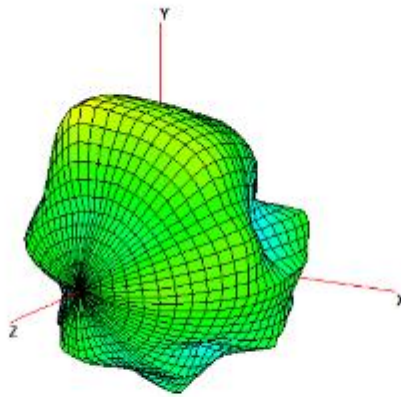

Center Frequency	<b>2315MHz</b>
Horizontal (dBi) peak	0.11
Vertical (dBi) peak	-2.18

### 2350MHz

Total

Azimuth = 0.0  
Elevation = -15.0  
Roll = -30.0

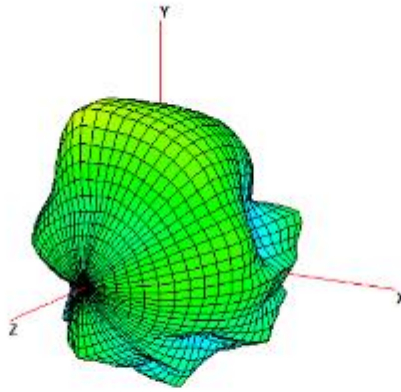

Center Frequency	<b>2350MHz</b>
Horizontal (dBi) peak	-0.54
Vertical (dBi) peak	-3.30

### 2400MHz

Total

Azimuth = 0.0  
Elevation = -15.0  
Roll = -30.0

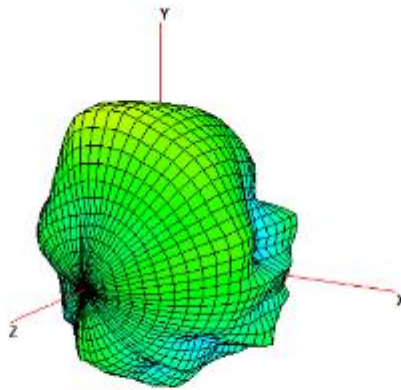

Center Frequency	<b>2400MHz</b>
Horizontal (dBi) peak	-0.23
Vertical (dBi) peak	-3.29

### 2500MHz

Total

Azimuth = 0.0  
Elevation = -15.0  
Roll = -30.0

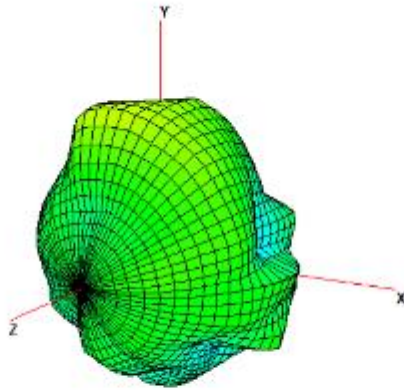

Center Frequency	<b>2500MHz</b>
Horizontal (dBi) peak	0.00
Vertical (dBi) peak	-2.64

### 2570MHz

Total

Azimuth = 0.0  
Elevation = -15.0  
Roll = -30.0

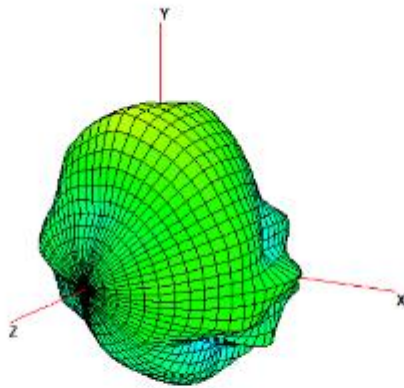

Center Frequency	<b>2570MHz</b>
Horizontal (dBi) peak	0.02
Vertical (dBi) peak	-3.22

### 2595MHz

Total

Azimuth = 0.0  
Elevation = -15.0  
Roll = -30.0

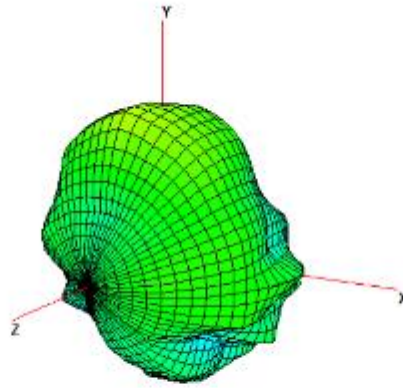

Center Frequency	<b>2595MHz</b>
Horizontal (dBi) peak	-0.13
Vertical (dBi) peak	-3.79

### 2620MHz

Total

Azimuth = 0.0  
Elevation = -15.0  
Roll = -30.0

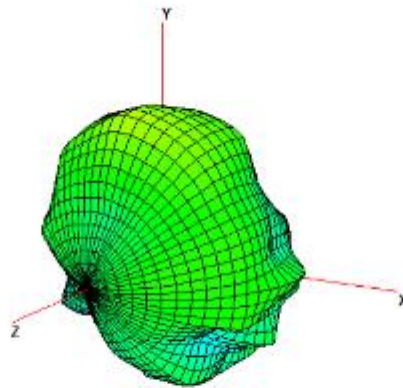

Center Frequency	<b>2620MHz</b>
Horizontal (dBi) peak	-0.21
Vertical (dBi) peak	-3.55

### 2690MHz

Total

Azimuth = 0.0  
Elevation = -15.0  
Roll = -30.0

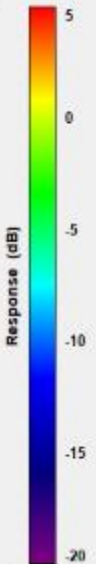
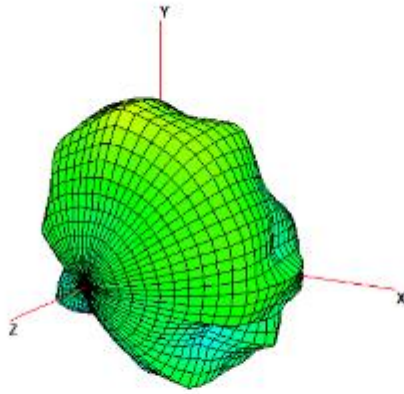

Center Frequency	<b>2690MHz</b>
Horizontal (dBi) peak	0.25
Vertical (dBi) peak	-2.66

### 3400MHz

Total

Azimuth = 0.0  
Elevation = -15.0  
Roll = -30.0

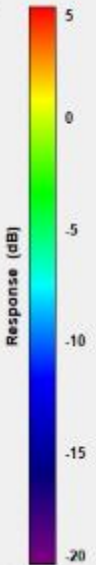
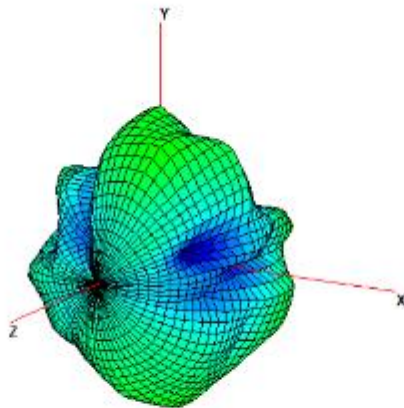

Center Frequency	<b>3400MHz</b>
Horizontal (dBi) peak	-2.46
Vertical (dBi) peak	-3.91

### 3500MHz

Total

Azimuth = 0.0  
Elevation = -15.0  
Roll = -30.0

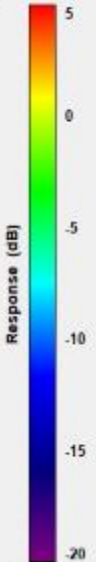
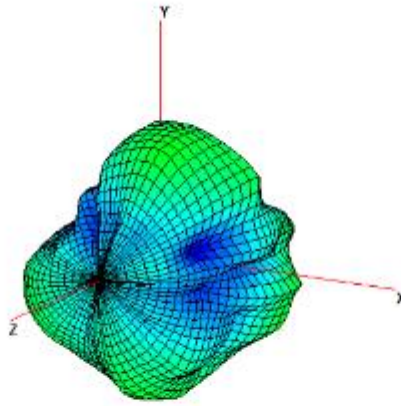

Center Frequency	<b>3500MHz</b>
Horizontal (dBi) peak	-2.20
Vertical (dBi) peak	-3.62

### 3600MHz

Total

Azimuth = 0.0  
Elevation = -15.0  
Roll = -30.0

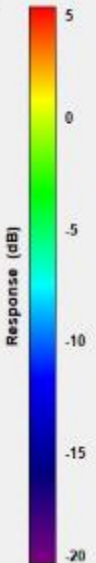
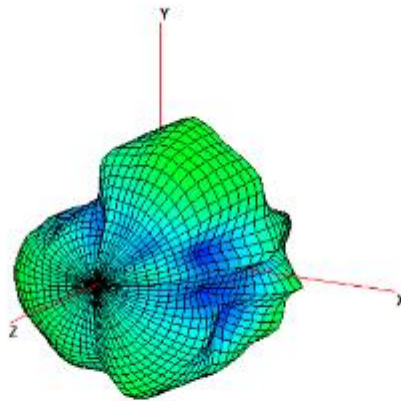

Center Frequency	<b>3600MHz</b>
Horizontal (dBi) peak	-3.45
Vertical (dBi) peak	-2.42

### 3700MHz

Total

Azimuth = 0.0  
Elevation = -15.0  
Roll = -30.0

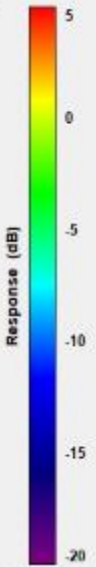
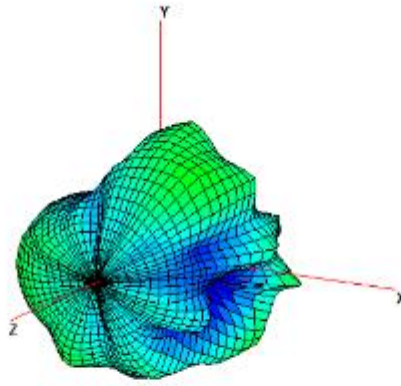

Center Frequency	<b>3700MHz</b>
Horizontal (dBi) peak	-3.05
Vertical (dBi) peak	-3.10

### 3800MHz

Total

Azimuth = 0.0  
Elevation = -15.0  
Roll = -30.0

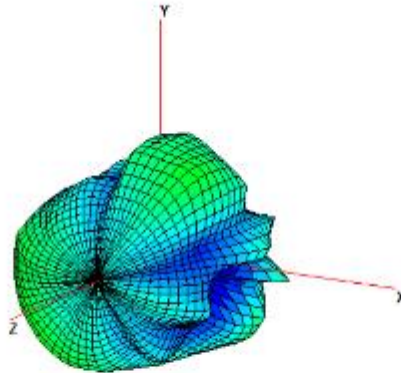

Center Frequency	<b>3800MHz</b>
Horizontal (dBi) peak	-2.41
Vertical (dBi) peak	-1.78

### 4200MHz

Total

Azimuth = 0.0  
Elevation = -15.0  
Roll = -30.0

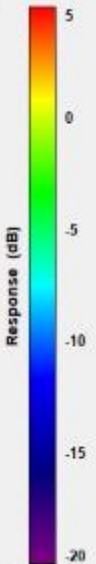
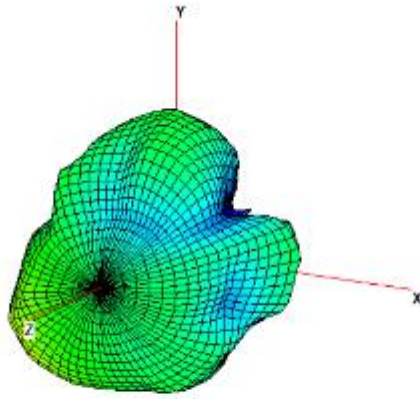

Center Frequency	<b>4200MHz</b>
Horizontal (dBi) peak	-1.95
Vertical (dBi) peak	0.75

### 4400MHz

Total

Azimuth = 0.0  
Elevation = -15.0  
Roll = -30.0

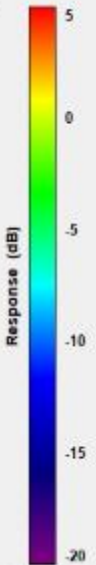
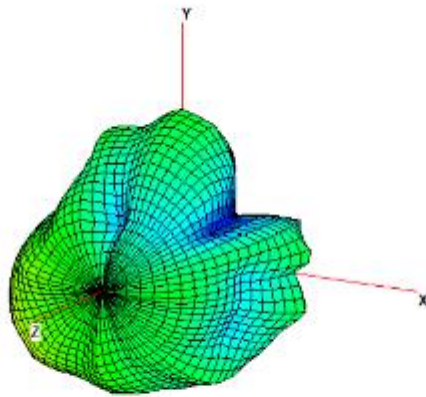

Center Frequency	<b>4400MHz</b>
Horizontal (dBi) peak	-2.55
Vertical (dBi) peak	0.81



### 4700MHz

Total

Azimuth = 0.0  
Elevation = -15.0  
Roll = -30.0

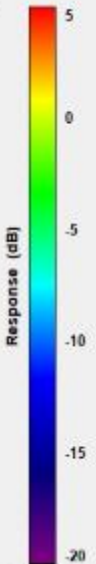
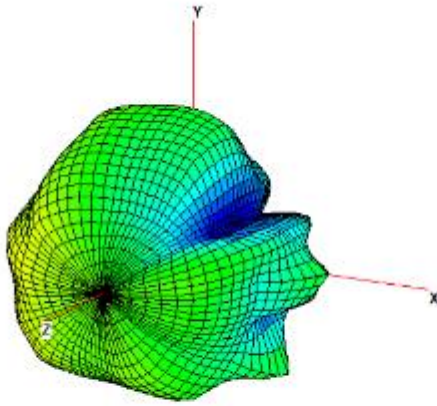

Center Frequency	<b>4700MHz</b>
Horizontal (dBi) peak	-1.56
Vertical (dBi) peak	1.10

### 5000MHz

Total

Azimuth = 0.0  
Elevation = -15.0  
Roll = -30.0

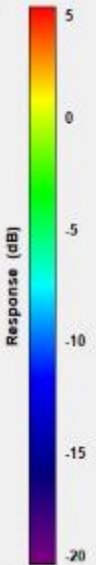
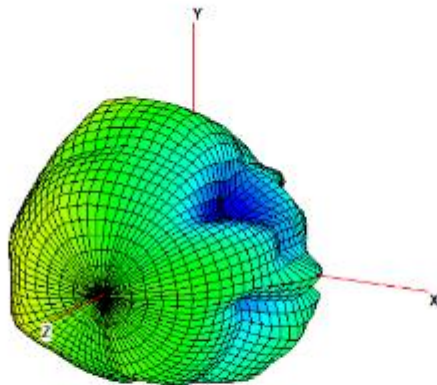

Center Frequency	<b>5000MHz</b>
Horizontal (dBi) peak	-0.49
Vertical (dBi) peak	0.89

## Section 4. Antenna Host Platform Location Information

Include a **dimensioned photo(s) or dimensioned drawing(s)** of Main and Aux antenna placements (measurements are not required for receive-only antenna).

Any antenna that transmits must show dimensions to bottom of laptop. Provide a description of the materials that are used for supporting or surrounding transmit antennas; for example, non-conductive plastics vs. conductive coated plastic or metallic materials.

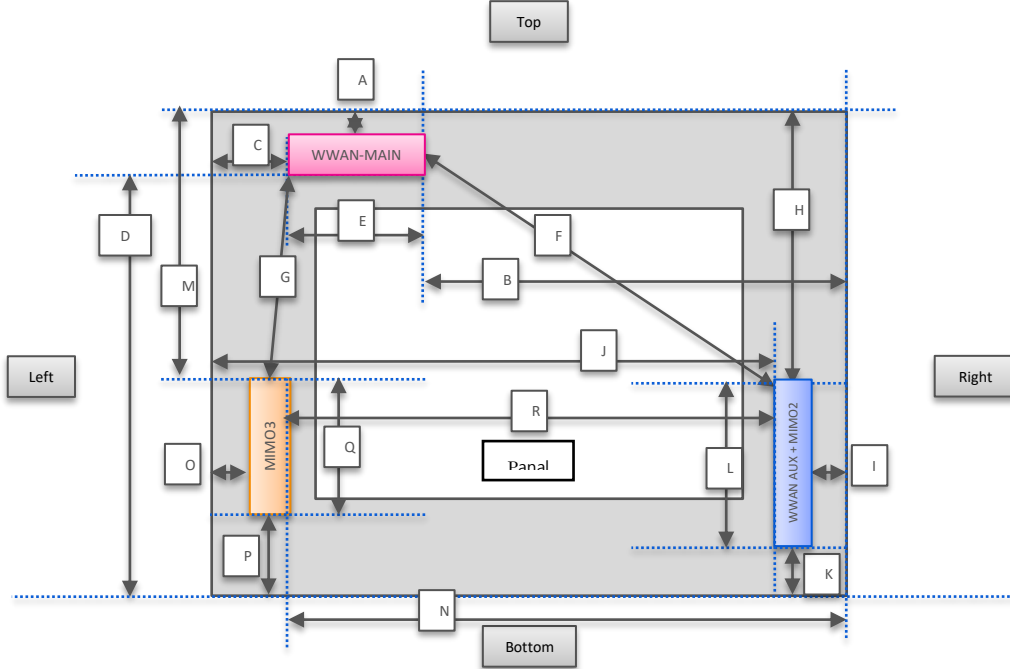

Minimum Separation Distance			
Item	Antenna	Position	Distance (mm)
A	WWAN-Main	to Top	2.1
B	WWAN-Main	to Right	191
C	WWAN-Main	to Left	24
D	WWAN-Main	to Bottom	190
E	WWAN-Main	Main Antenna Length	79
F	Main-Aux	Main to Aux	204
G	Main-MIMO3	Main-MIMO3	120
H	WWAN-AUX	to Top	113
I	WWAN-AUX	to Right	4.1
J	WWAN-AUX	to Left	281
K	WWAN-AUX	to Bottom	17
L	WWAN-AUX	Aux Antenna Length	74.6
M	WWAN-MIMO3	to Top	130
N	WWAN-MIMO3	to Right	284.5
O	WWAN-MIMO3	to Left	4.1

P	WWAN-MIMO3	to Bottom	16.8
Q	WWAN-MIMO3	MIMO3 Antenna Length	61.2
R	AUX-MIMO3	AUX-MIMO3	270
S	WWAN--Main	to Front	2.5
T	WWAN--Main	to Rear	6.9
U	WWAN--Aux	to Front	2.55
V	WWAN-Aux	to Rear	6.9
W	WWAN-MIMO3	to Front	2.55
X	WWAN-MIMO3	to Rear	6.9

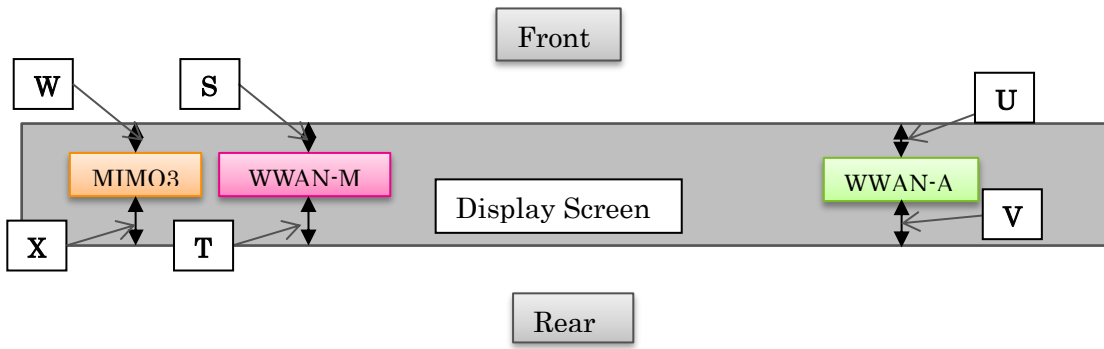

## Section 5. Antenna dimensional information for SAR evaluation

Include a **dimensioned photo(s) or dimensioned drawing(s)** showing the distance (mm) between the transmit antennas and the user. For notebook/laptop hosts show lapheld position (example below). For tablet hosts show all orientations including lapheld, primary & secondary portrait, primary & secondary landscape positions. Include a description of any proximity sensors or power throttling implementations that limit or exclude use of any host orientation.

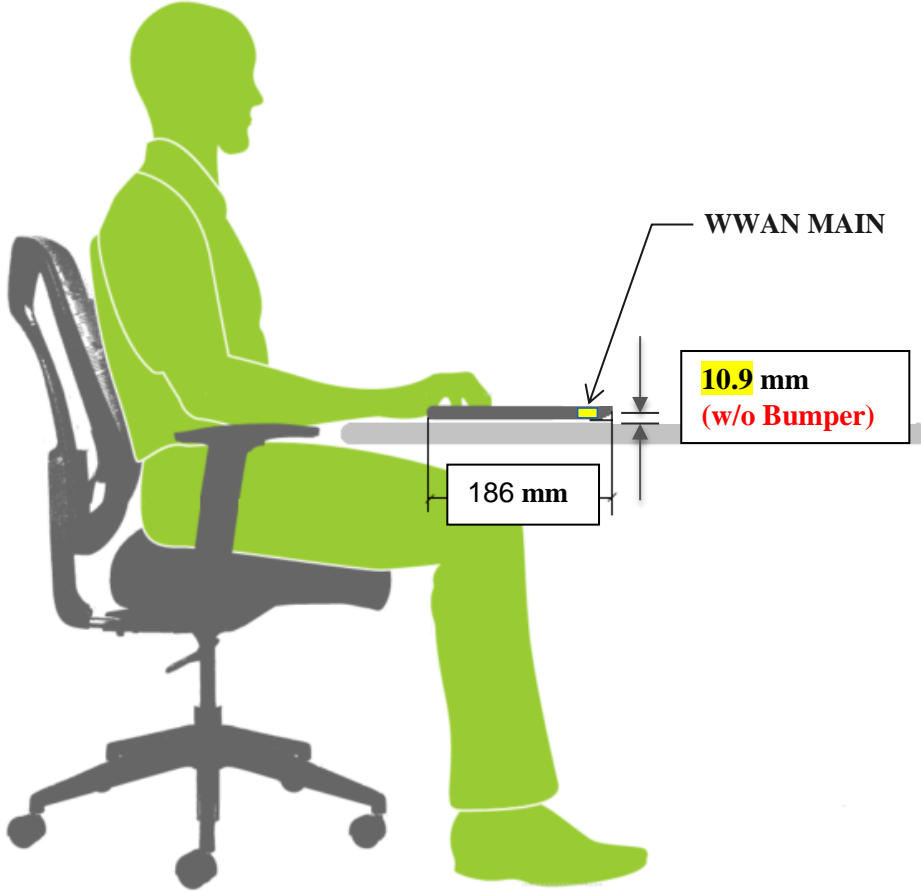

## Section 6. Diagram Example of Co-Location Antenna Separation

Include a **dimensioned photo or dimensioned drawing** showing the distance (mm) between **all WLAN transmit antennas** and other co-located radiator transmit antenna such as Bluetooth, WWAN,..

(Note: Due to the evolving rules regarding co-location, each platform will need to be reviewed on a case by case basis)

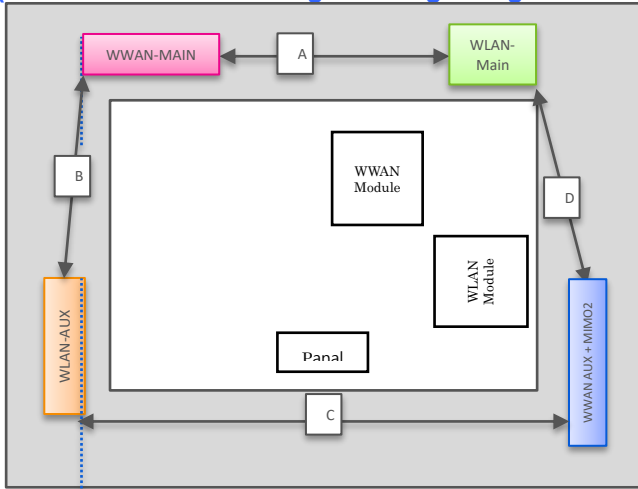

Minimum Separation Distance			
Item	Antenna	between	Distance (mm)
A	WLAN-Main	WWAN MAIN	147
B	WWAN-Main	WLAN -AUX	116
C	WLAN-Aux	MIMO2	268
D	MIMO2	WLAN-Main	92