

TB mode

WWAN Main Antenna (Tx1/Rx1)

617MHz

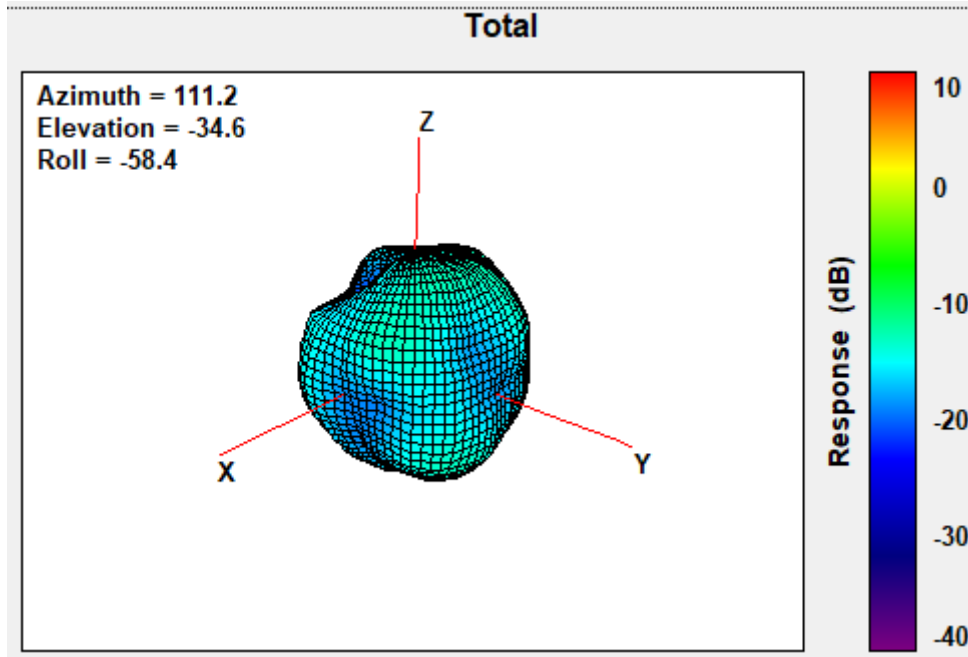

635MHz

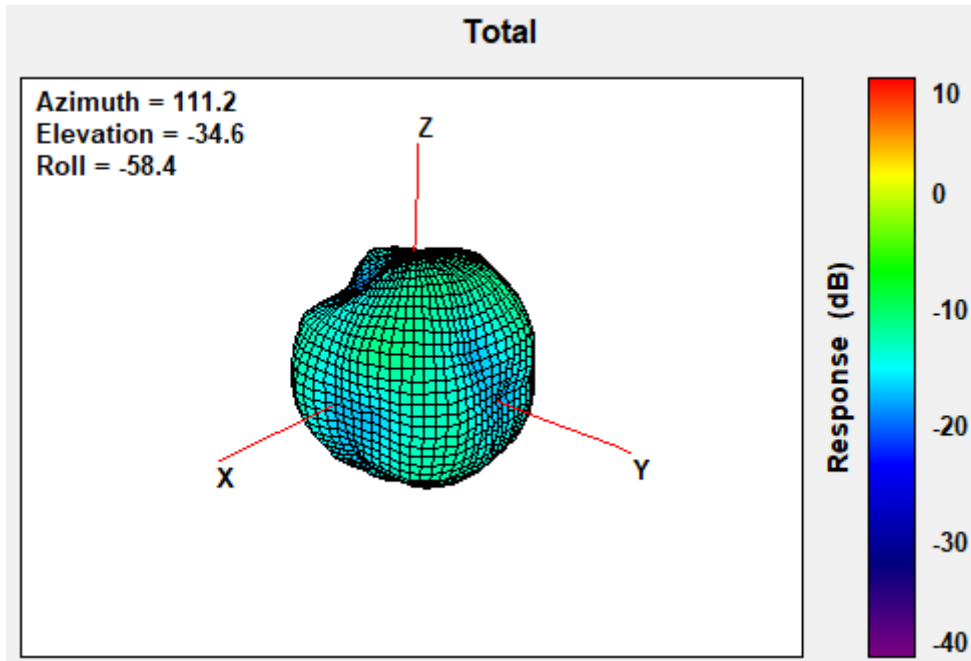

652MHz

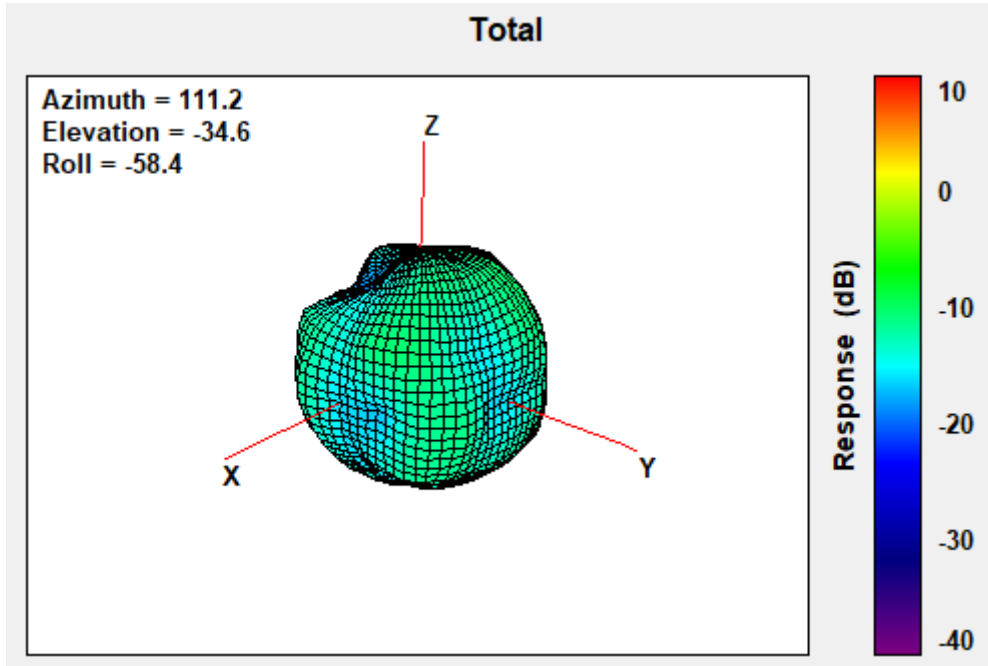

Center Frequency	652 MHz
Horizontal (dBi) peak	-15.72
Vertical (dBi) peak	-15.09

663MHz

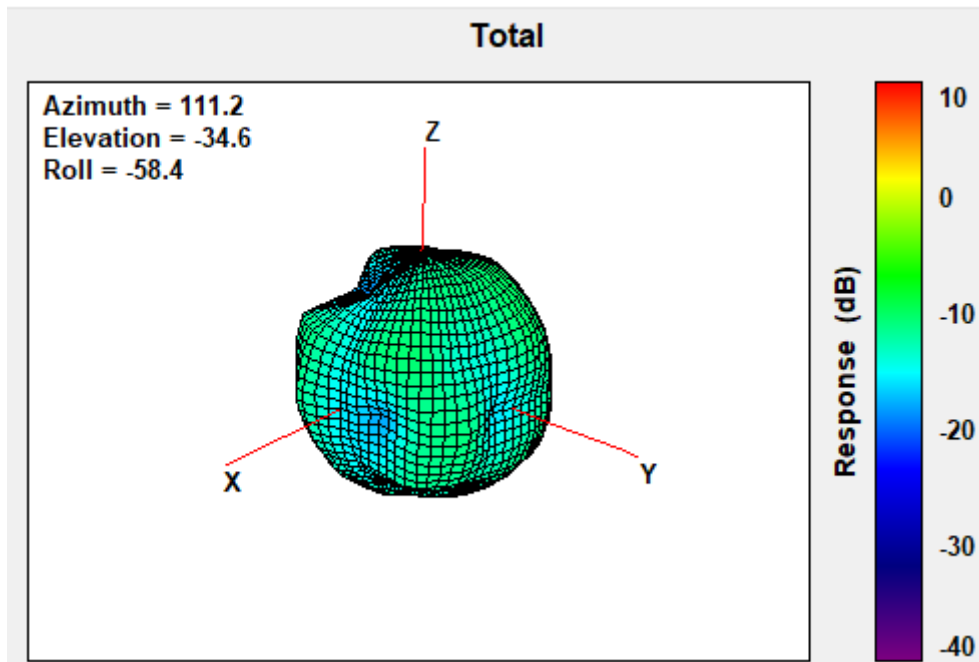

Center Frequency	663 MHz
Horizontal (dBi) peak	-14.99
Vertical (dBi) peak	-14.55

681MHz

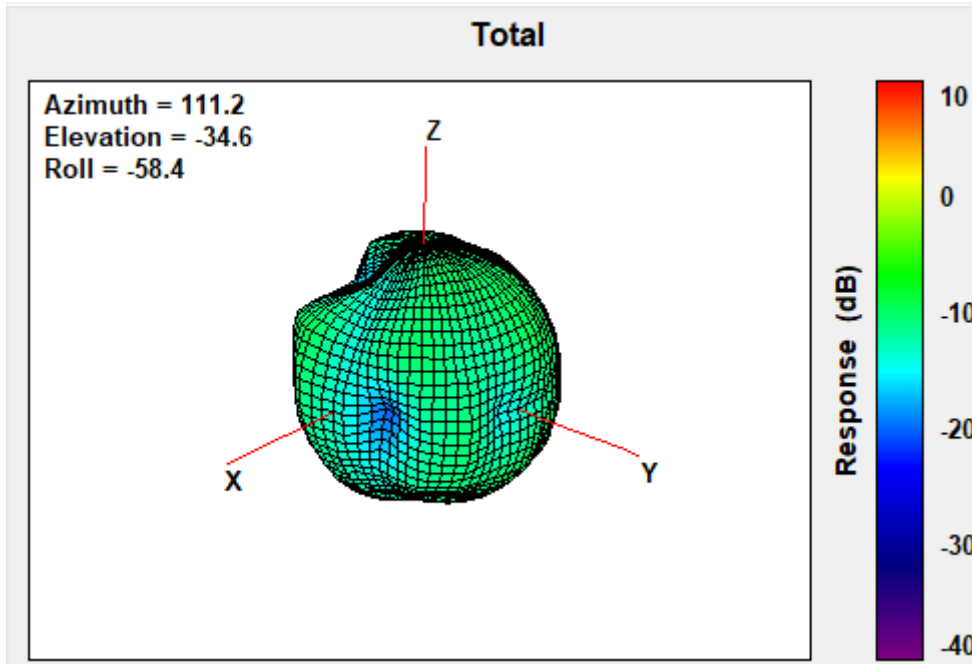

698MHz

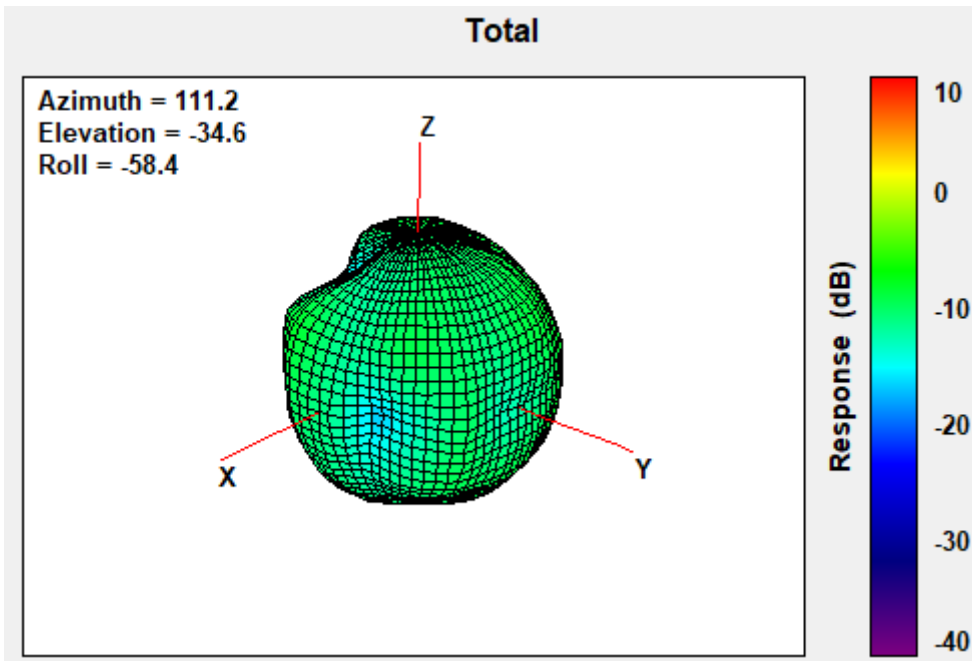

703MHz

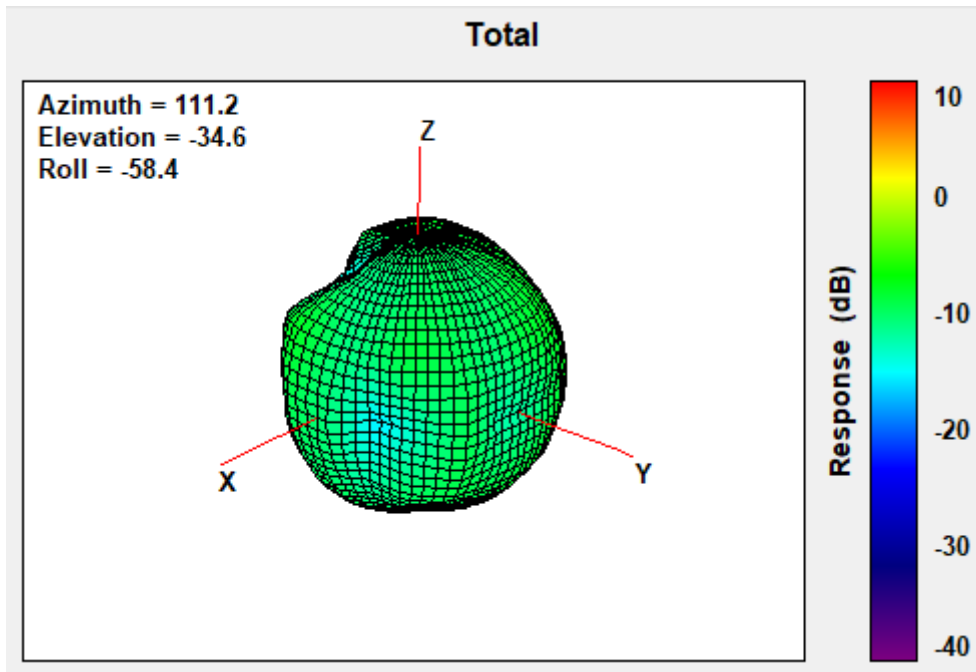

Center Frequency	703MHz
Horizontal (dBi) peak	-6.62
Vertical (dBi) peak	-6.18

707.5MHz

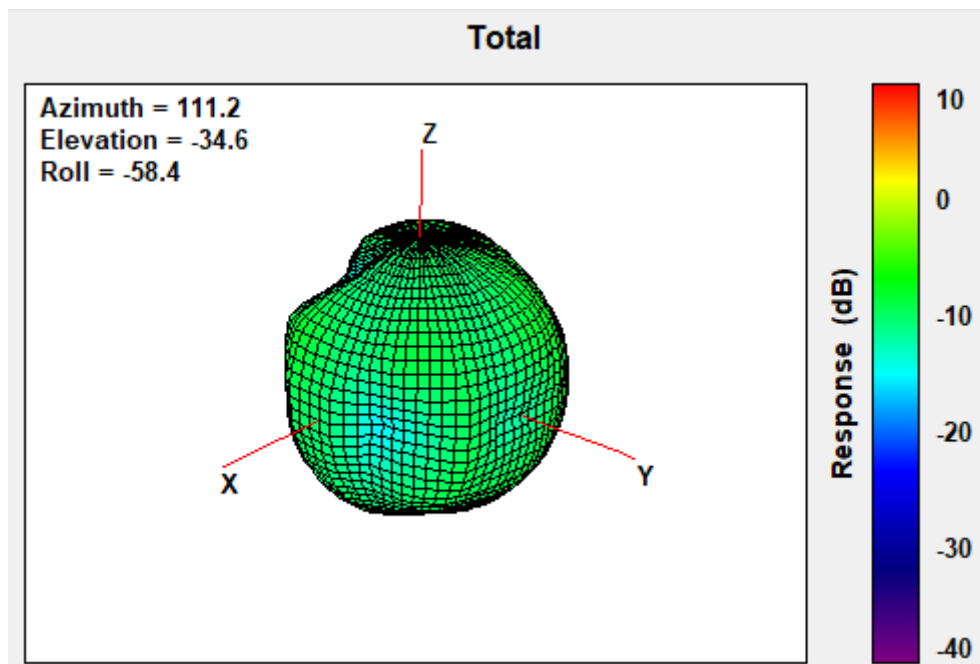

Center Frequency	707.5MHz
Horizontal (dBi) peak	-6.44
Vertical (dBi) peak	-6.24

717MHz

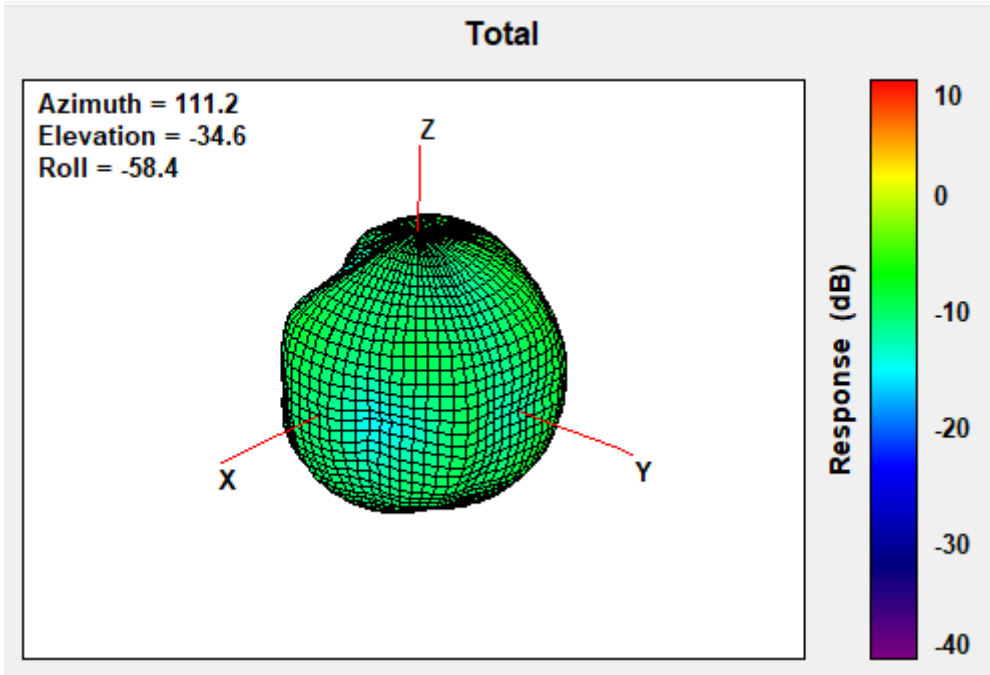

Center Frequency	717MHz
Horizontal (dBi) peak	-6.17
Vertical (dBi) peak	-6.24

725.5MHz

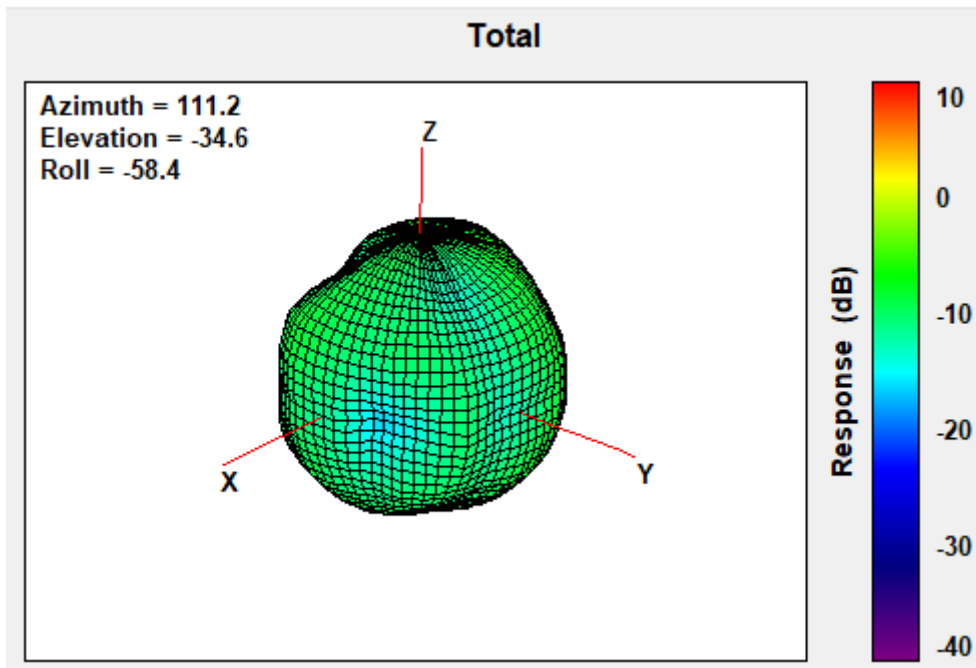

Center Frequency	725.5MHz
Horizontal (dBi) peak	-6.21
Vertical (dBi) peak	-6.77

748MHz

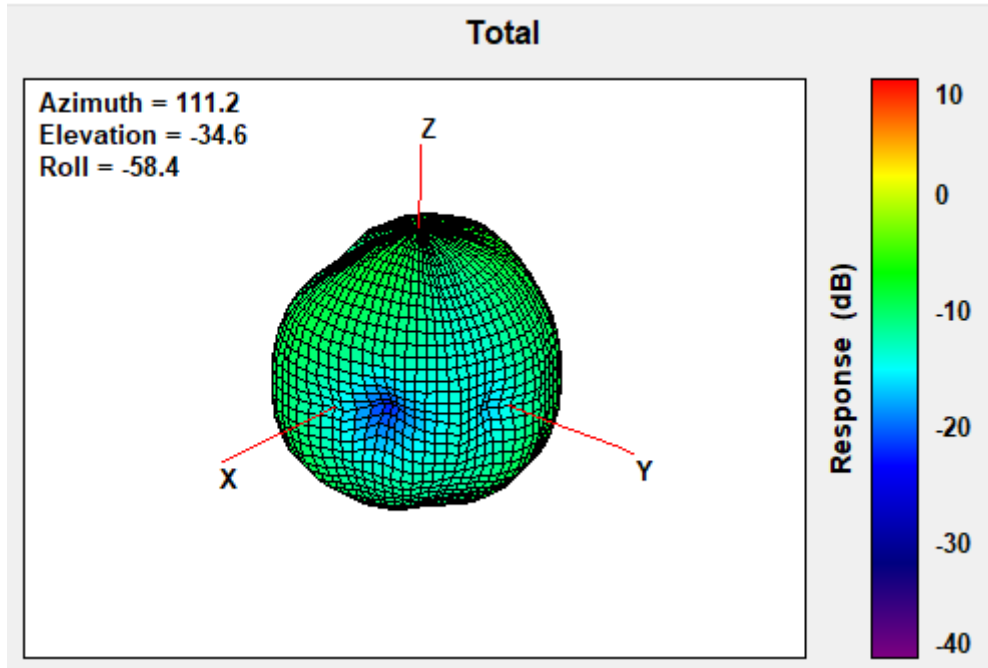

Center Frequency	748MHz
Horizontal (dBi) peak	-7.50
Vertical (dBi) peak	-6.87

756MHz

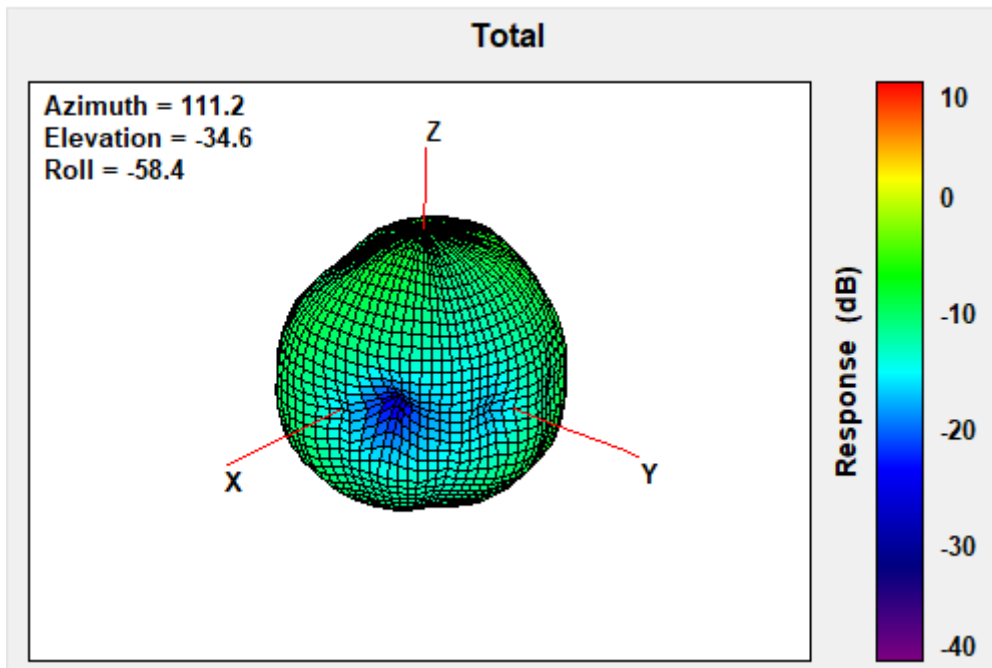

Center Frequency	756MHz
Horizontal (dBi) peak	-7.96
Vertical (dBi) peak	-6.60

768MHz

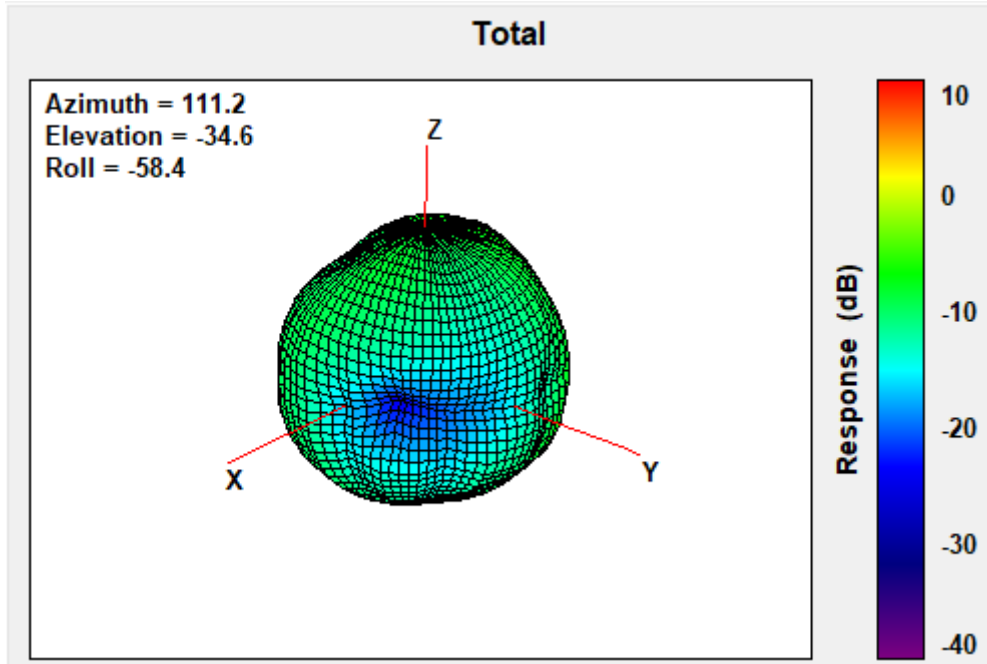

Center Frequency	768MHz
Horizontal (dBi) peak	-8.34
Vertical (dBi) peak	-6.47

777MHz

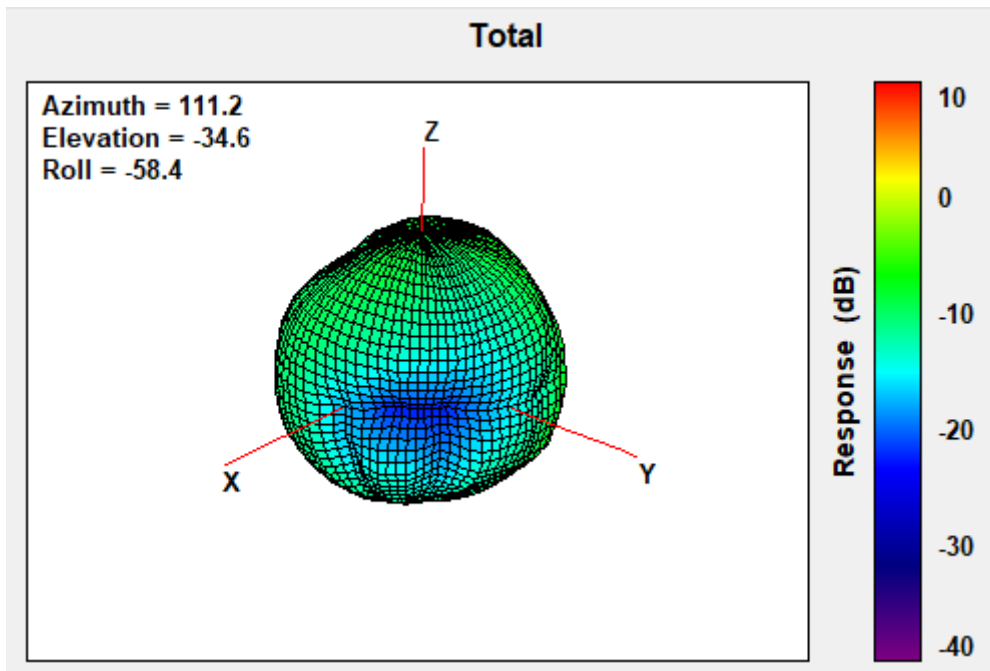

Center Frequency	777MHz
Horizontal (dBi) peak	-8.67
Vertical (dBi) peak	-6.73

782MHz

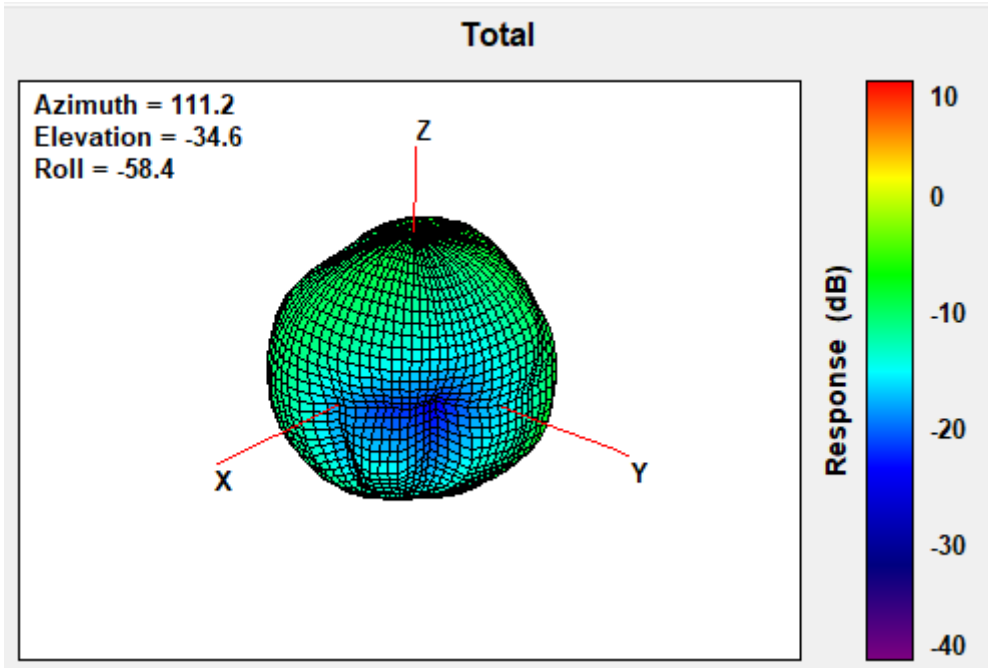

Center Frequency	782MHz
Horizontal (dBi) peak	-9.01
Vertical (dBi) peak	-6.96

787MHz

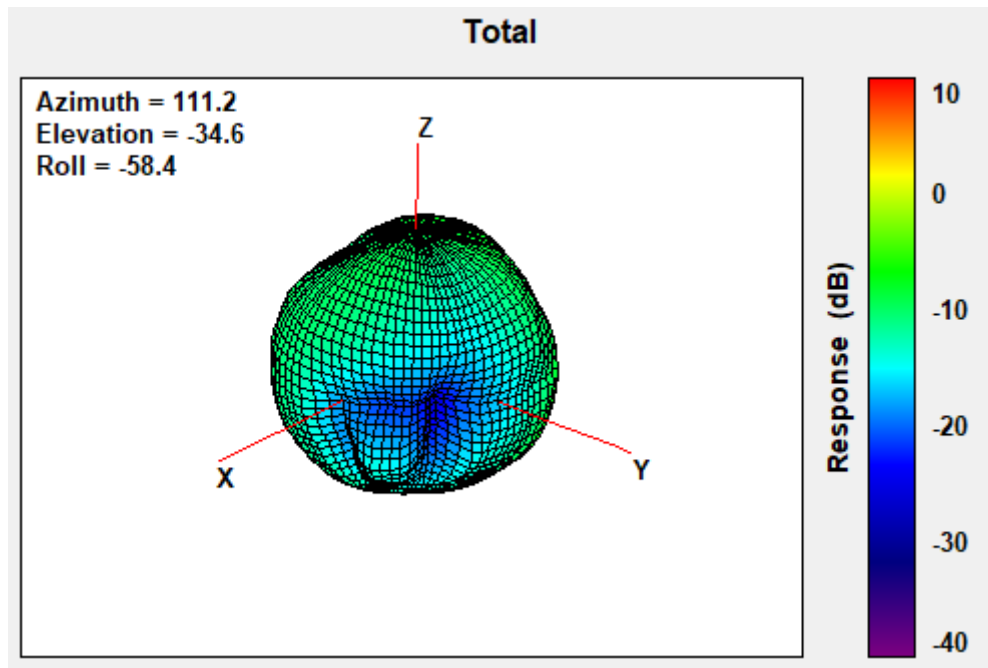

Center Frequency	787MHz
Horizontal (dBi) peak	-9.39
Vertical (dBi) peak	-6.96

814MHz

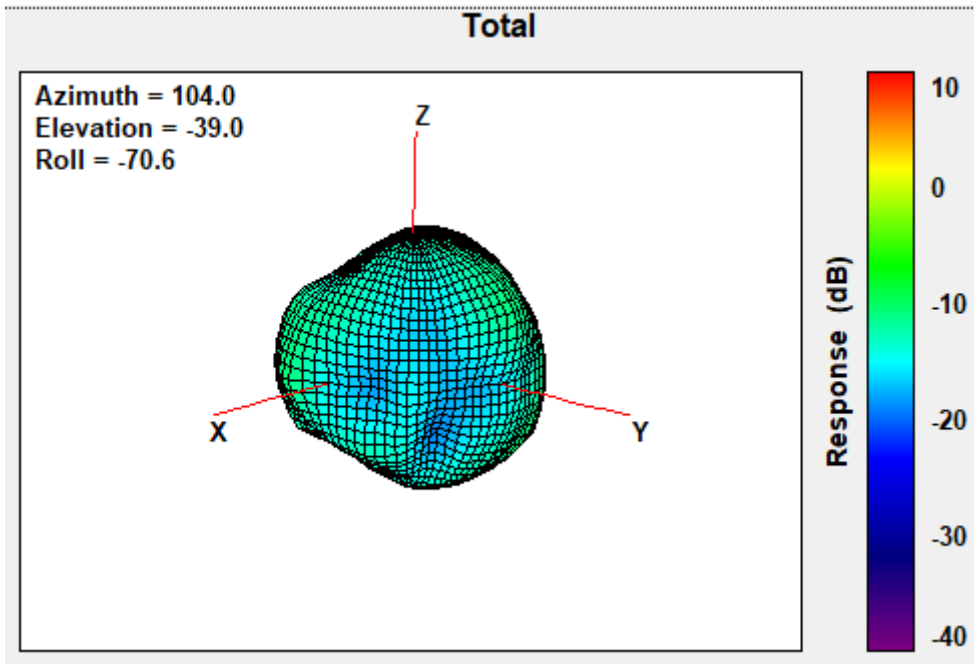

824MHz

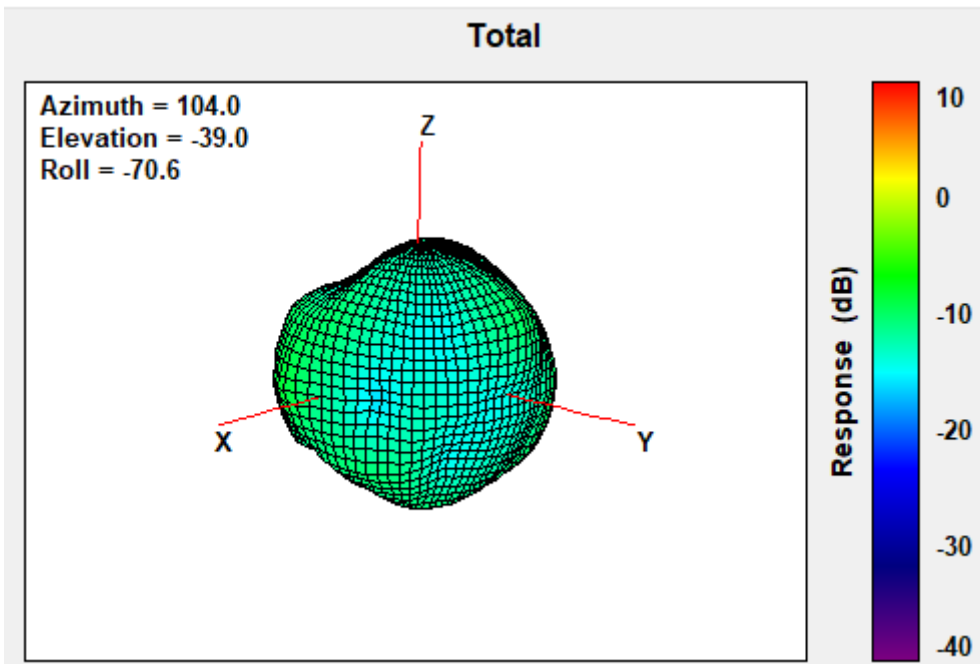

832MHz

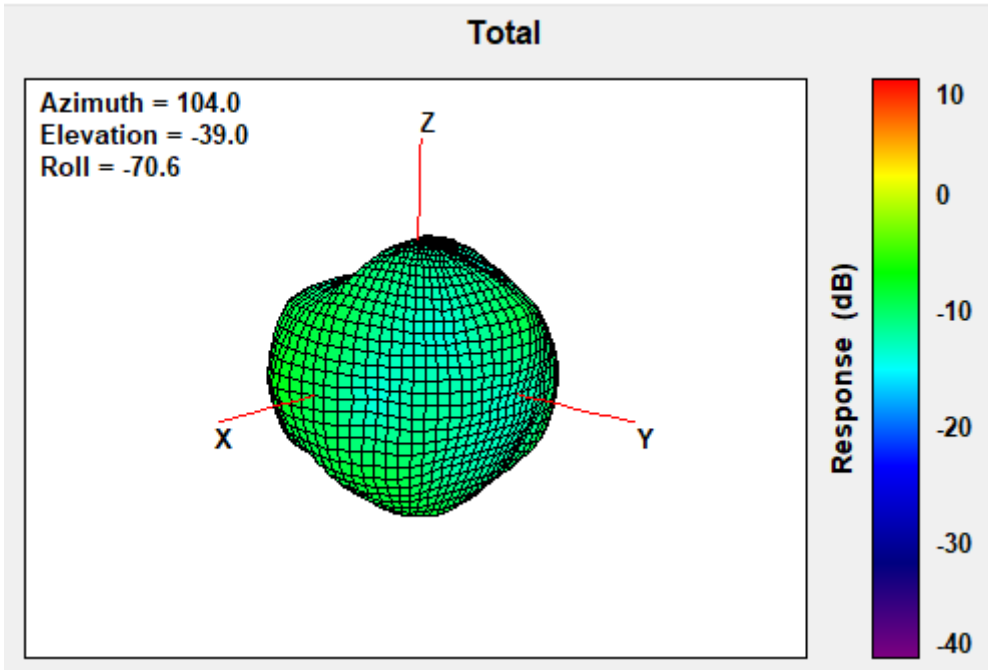

Center Frequency	832MHz
Horizontal (dBi) peak	-7.01
Vertical (dBi) peak	-5.31

836.5MHz

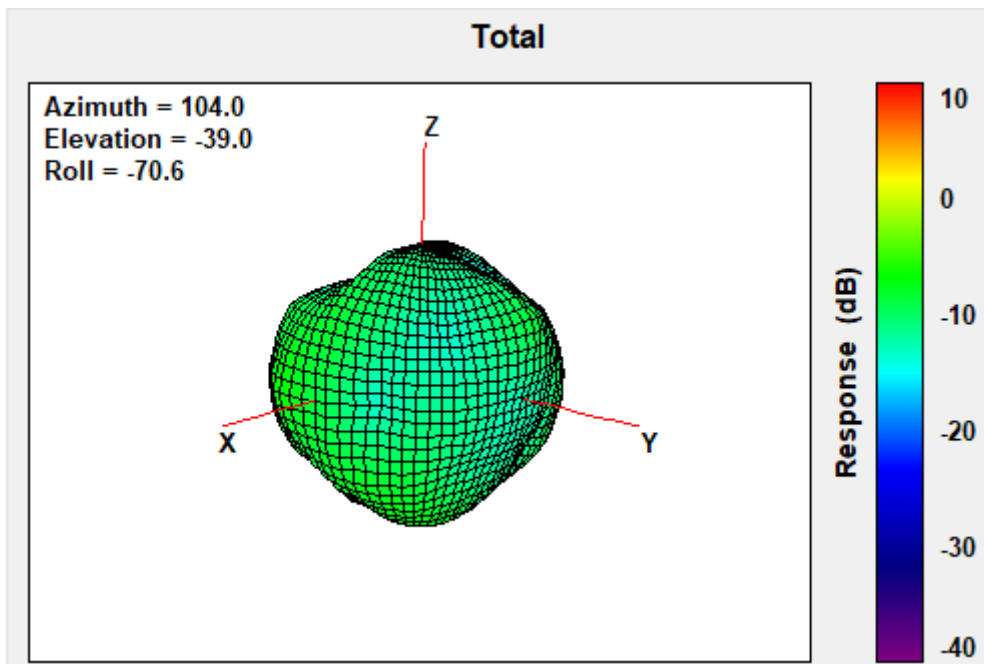

Center Frequency	836.5MHz
Horizontal (dBi) peak	-6.42
Vertical (dBi) peak	-5.14

849MHz

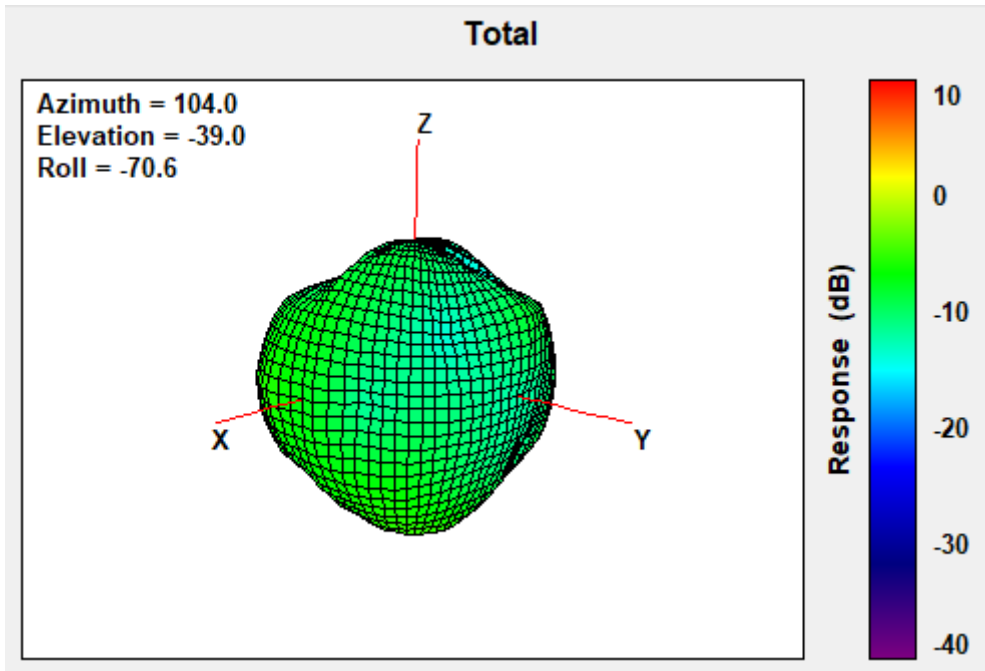

Center Frequency	849MHz
Horizontal (dBi) peak	-4.78
Vertical (dBi) peak	-5.22

862MHz

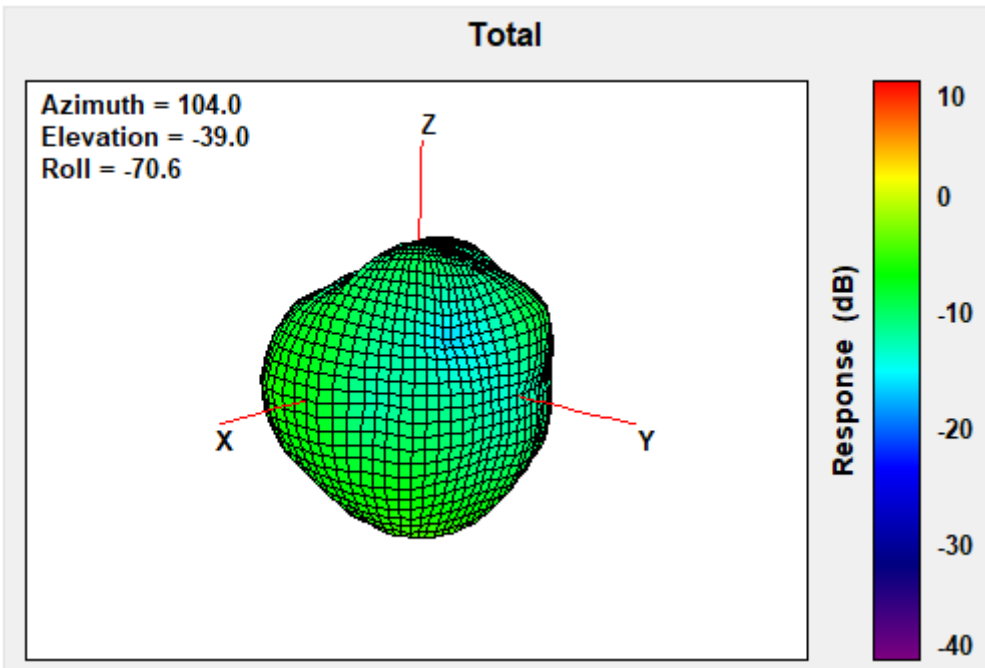

Center Frequency	862MHz
Horizontal (dBi) peak	-4.25
Vertical (dBi) peak	-5.64

880MHz

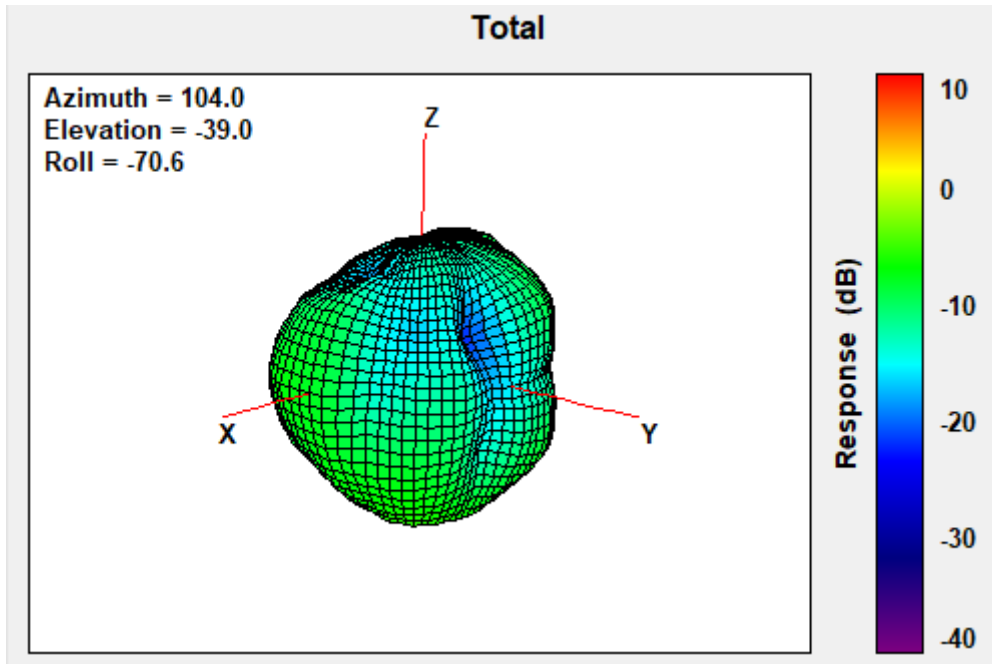

897.5MHz

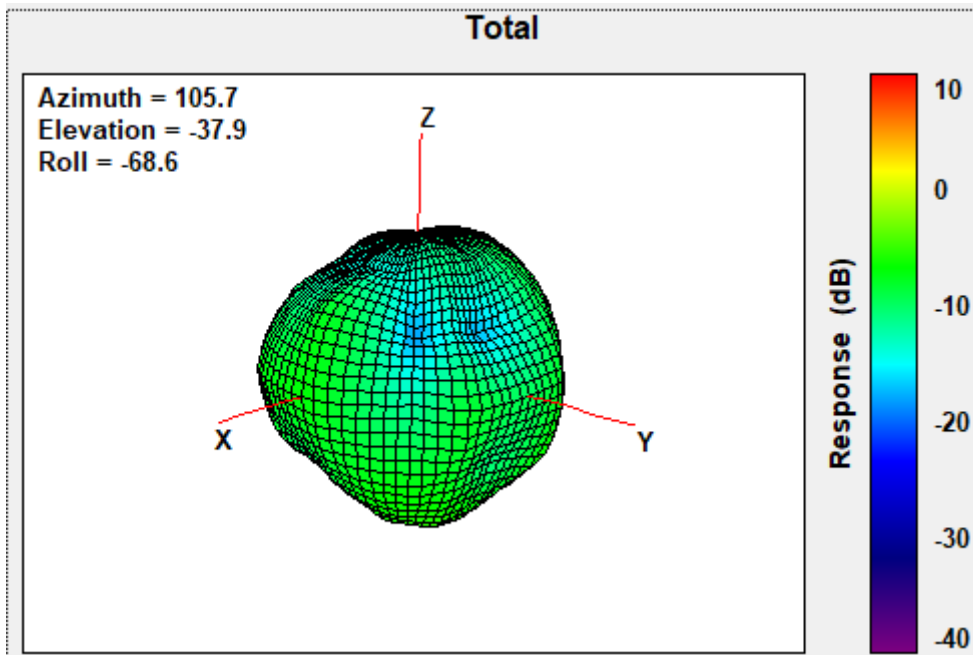

915MHz

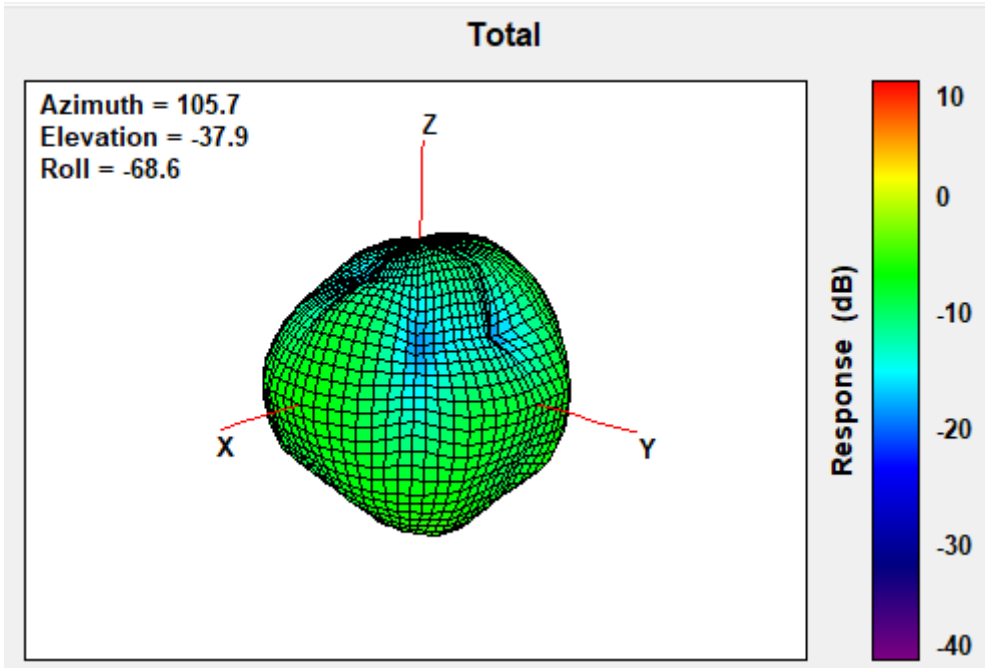

Center Frequency	915MHz
Horizontal (dBi) peak	-5.28
Vertical (dBi) peak	-4.25

925MHz

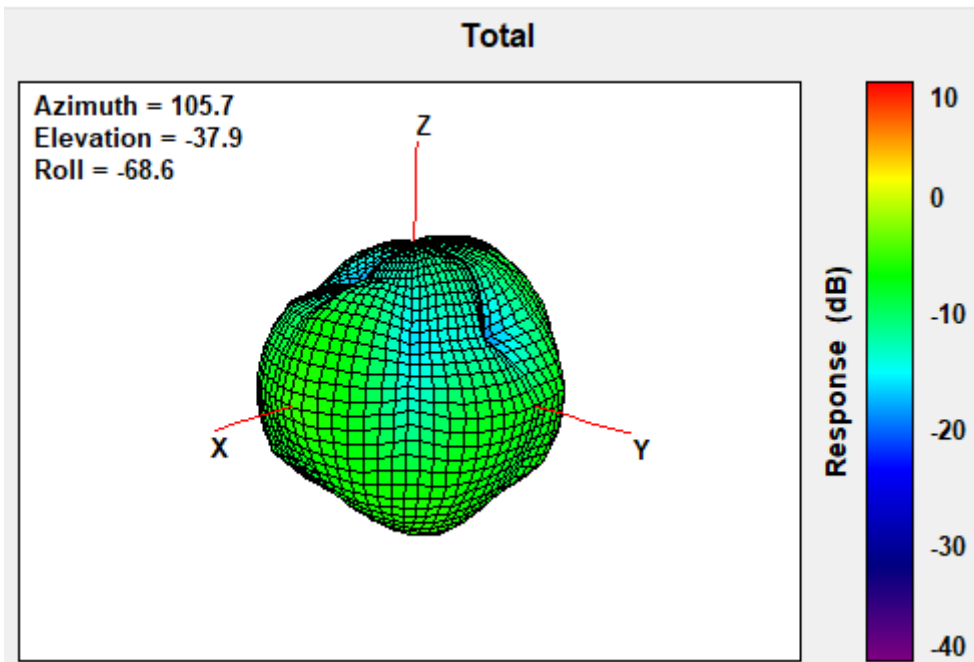

Center Frequency	925MHz
Horizontal (dBi) peak	-5.54
Vertical (dBi) peak	-4.16

960MHz

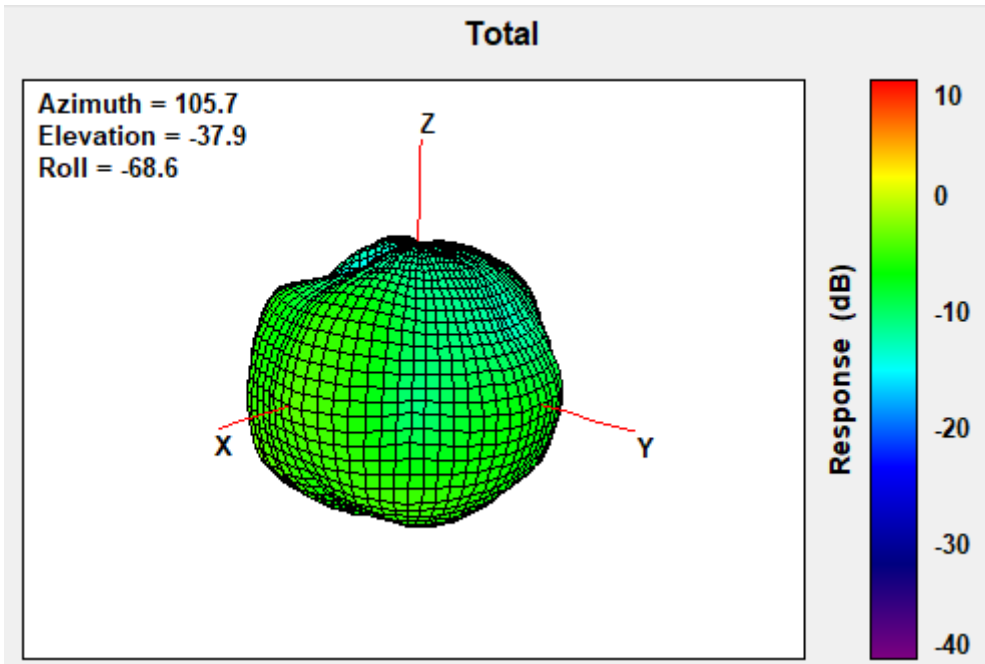

Center Frequency	960MHz
Horizontal (dBi) peak	-4.92
Vertical (dBi) peak	-4.34

1427.9MHz

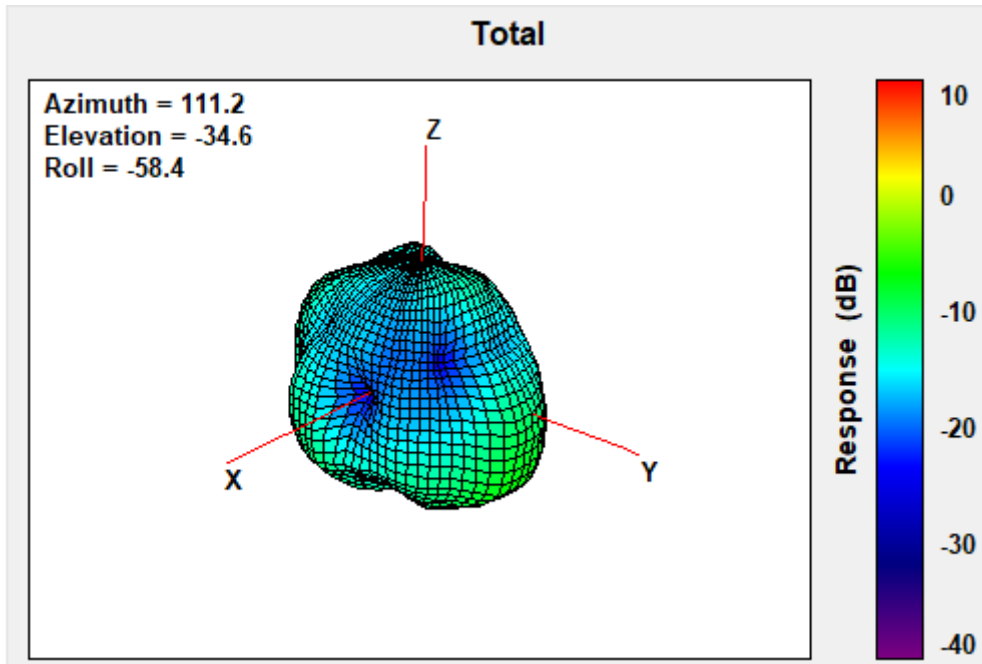

Center Frequency	1427.9MHz
Horizontal (dBi) peak	-6.67
Vertical (dBi) peak	-9.71

1447.9MHz

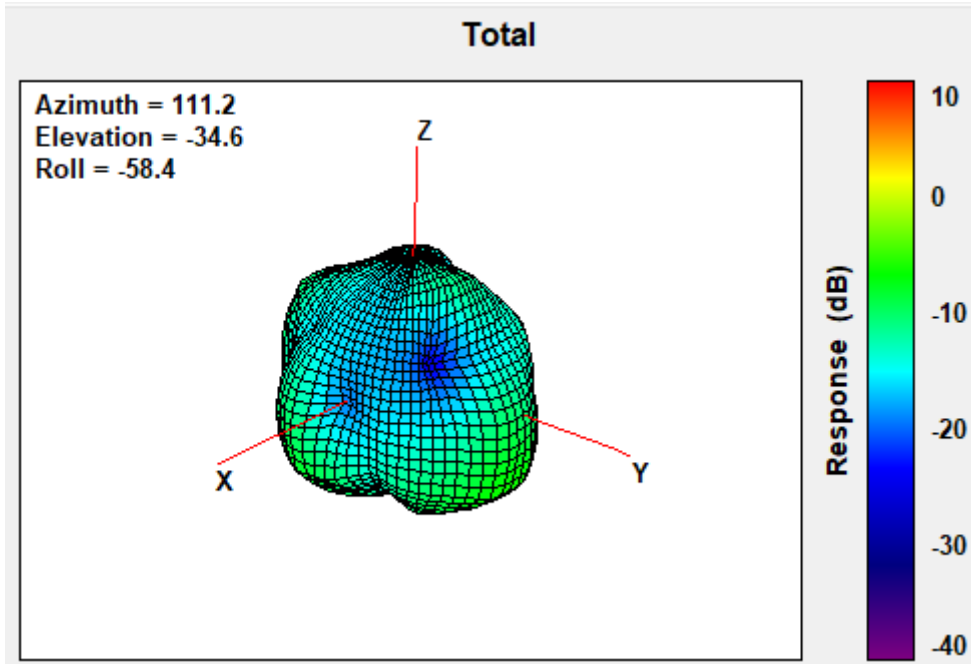

Center Frequency	1447.9MHz
Horizontal (dBi) peak	-6.15
Vertical (dBi) peak	-8.71

1455.4MHz

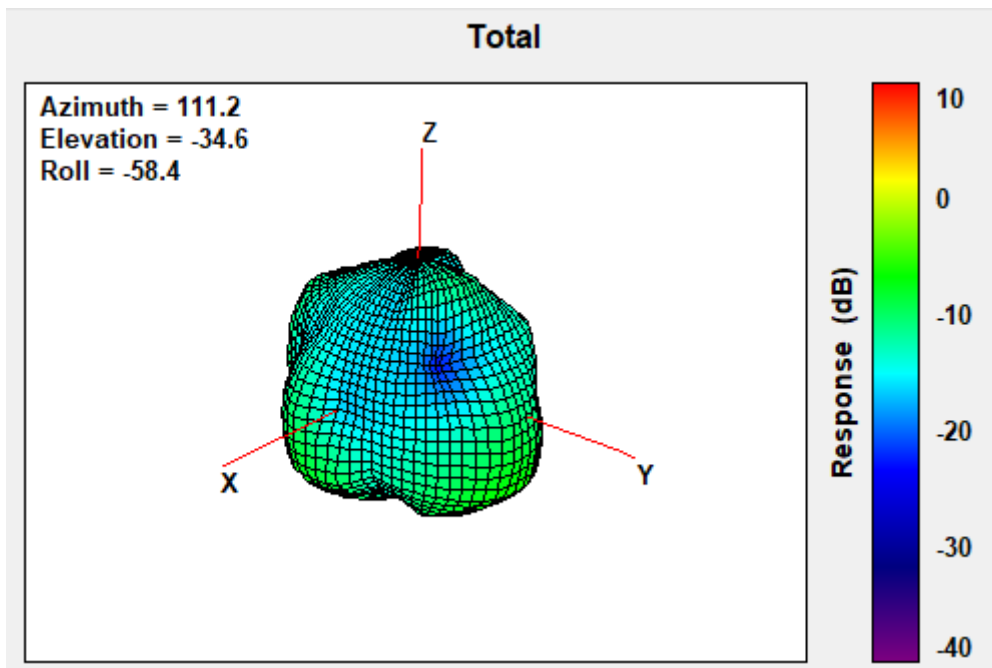

Center Frequency	1455.4MHz
Horizontal (dBi) peak	-6.20
Vertical (dBi) peak	-8.64

1462.9MHz

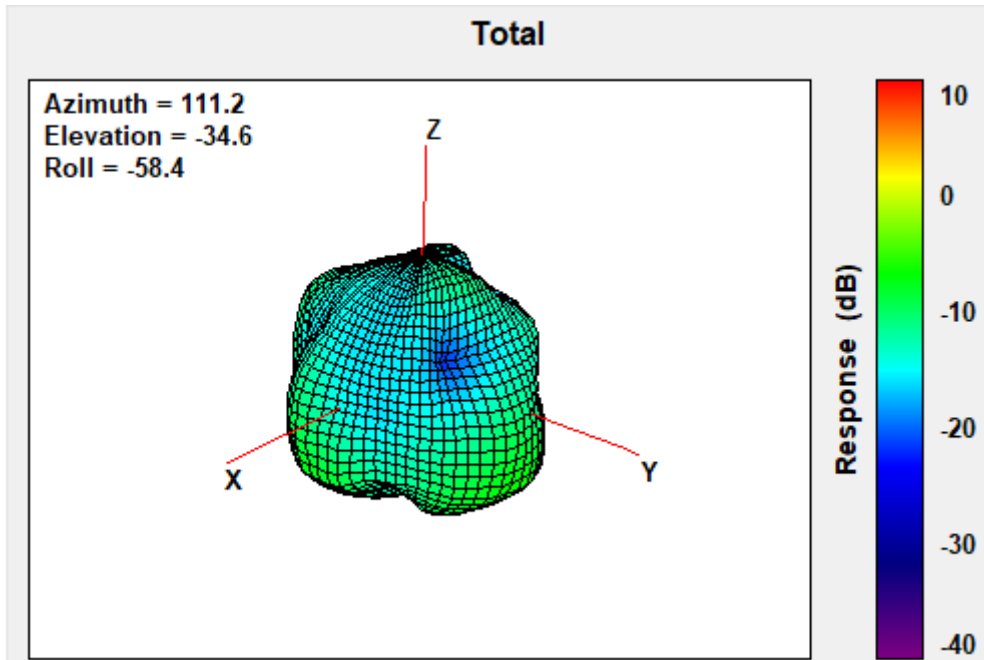

Center Frequency	1462.9MHz
Horizontal (dBi) peak	-6.20
Vertical (dBi) peak	-8.82

1496MHz

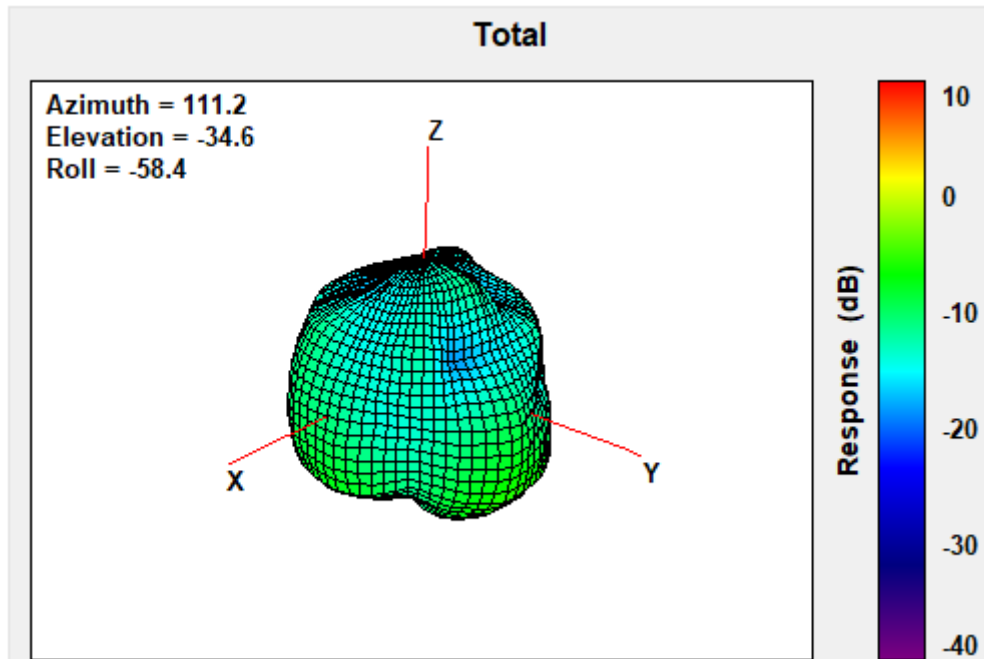

Center Frequency	1496MHz
Horizontal (dBi) peak	-5.88
Vertical (dBi) peak	-7.34

1510.9 MHz

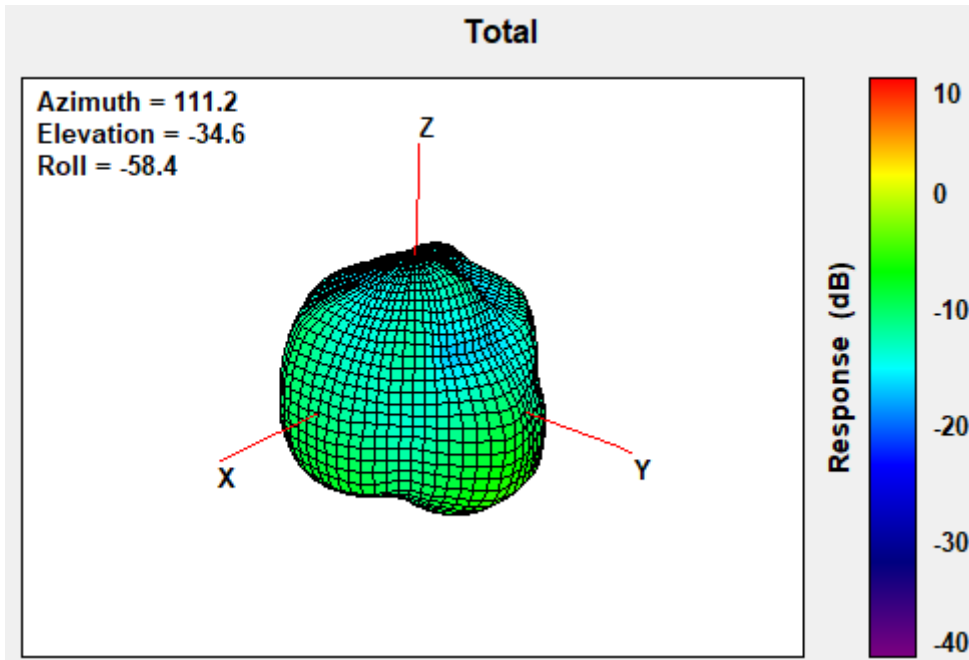

Center Frequency	1510.9 MHz
Horizontal (dBi) peak	-5.39
Vertical (dBi) peak	-7.63

1710 MHz

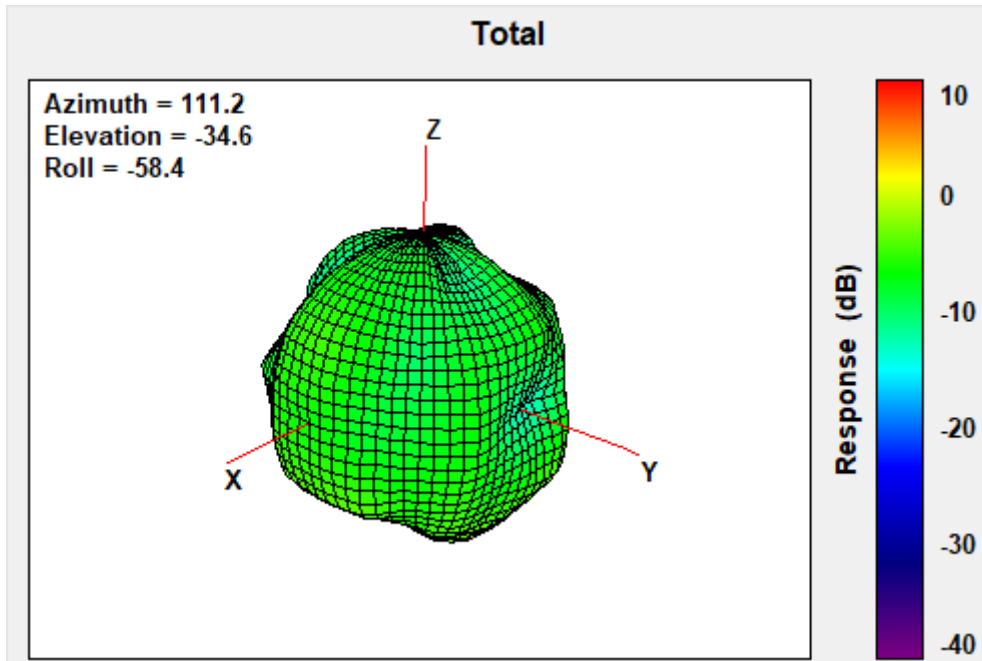

Center Frequency	1710 MHz
Horizontal (dBi) peak	-1.86
Vertical (dBi) peak	-3.84

1732.5 MHz

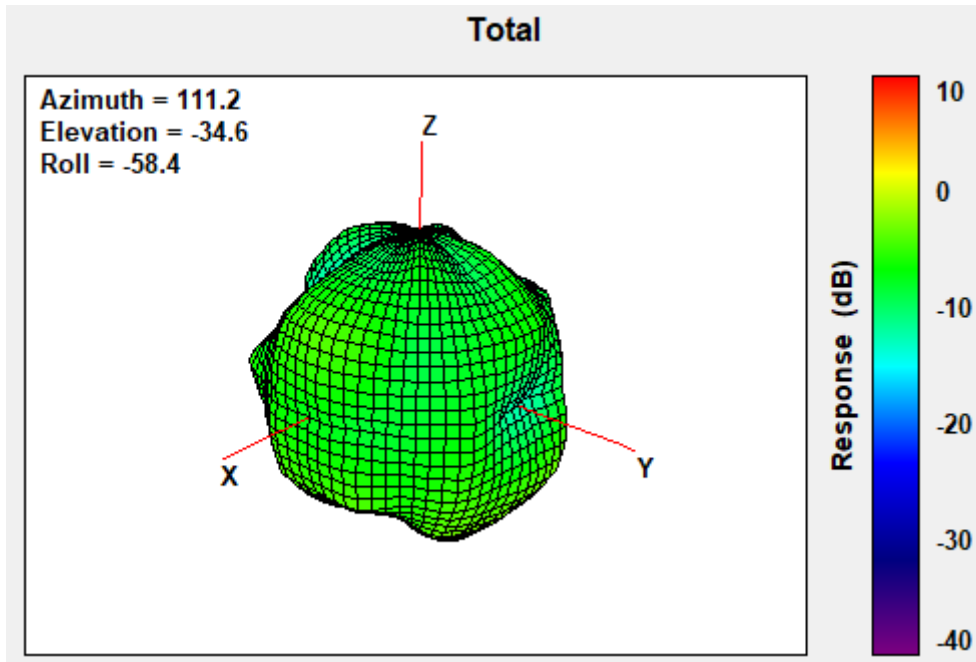

1747.5 MHz

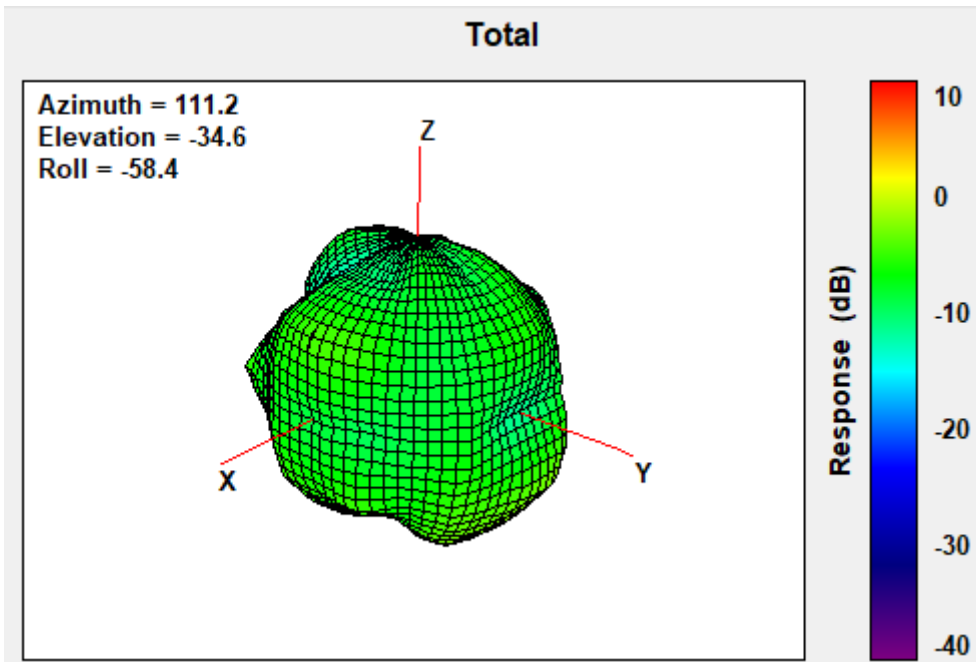

1755 MHz

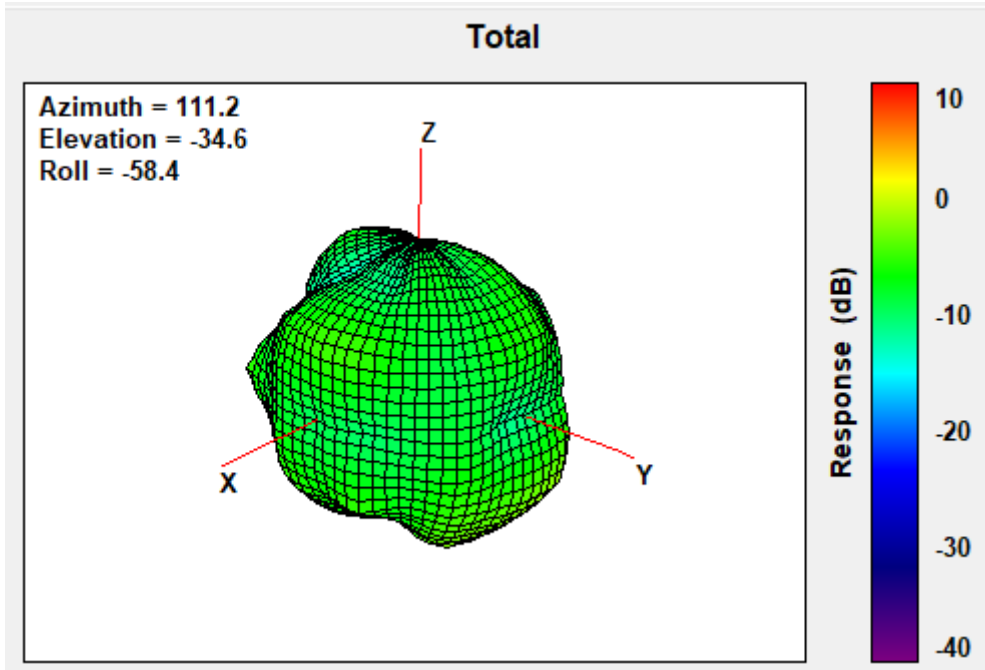

Center Frequency	1755 MHz
Horizontal (dBi) peak	-0.98
Vertical (dBi) peak	-4.07

1785 MHz

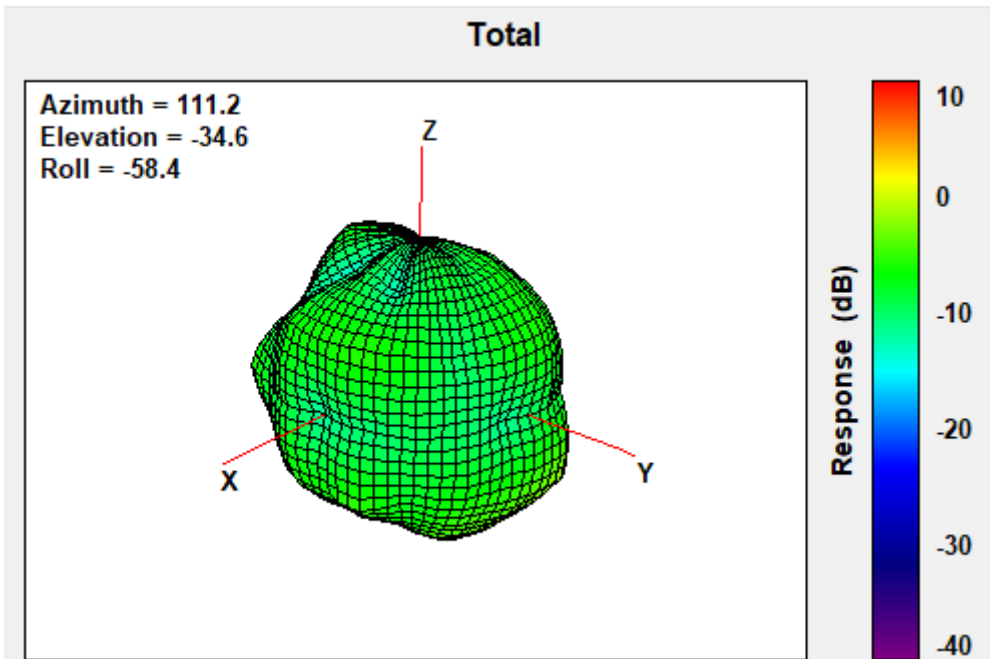

Center Frequency	1785 MHz
Horizontal (dBi) peak	-0.80
Vertical (dBi) peak	-4.25

1805 MHz

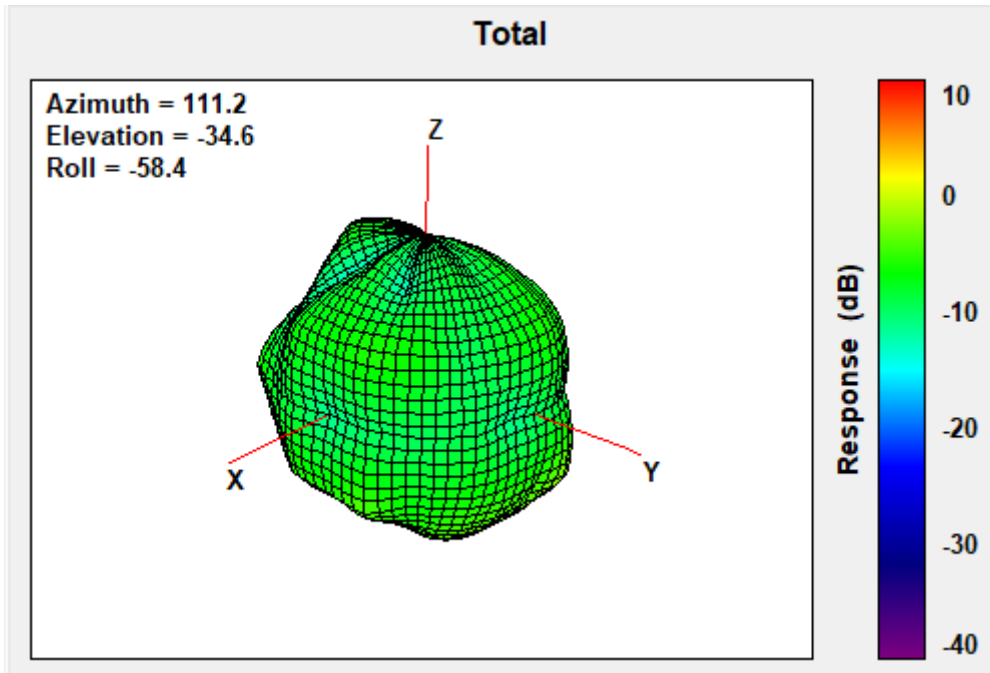

Center Frequency	1805 MHz
Horizontal (dBi) peak	-1.41
Vertical (dBi) peak	-4.27

1850 MHz

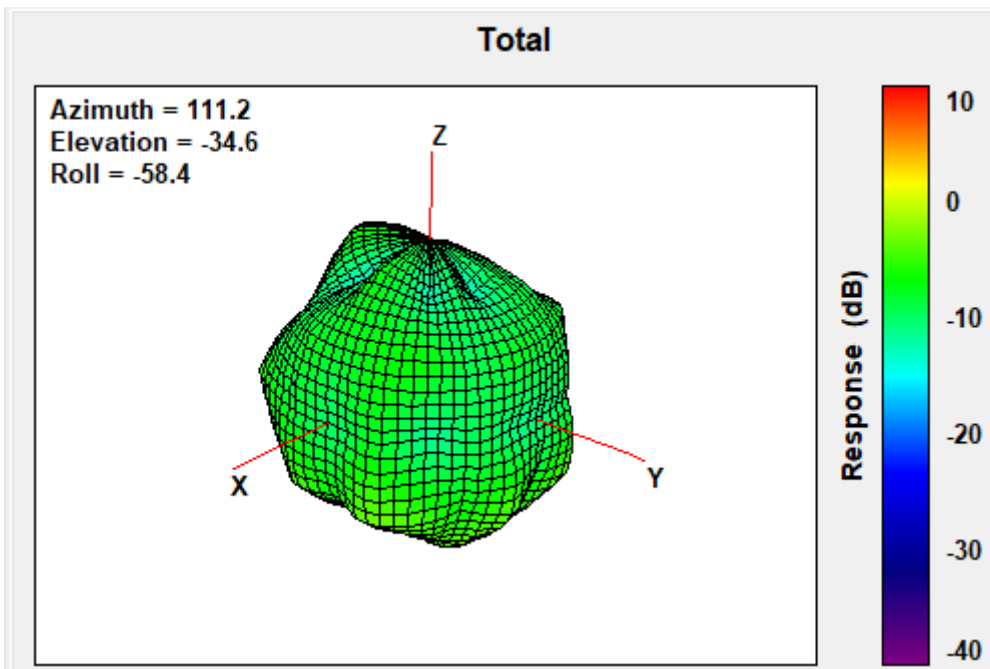

Center Frequency	1850 MHz
Horizontal (dBi) peak	-3.43
Vertical (dBi) peak	-4.58

1880 MHz

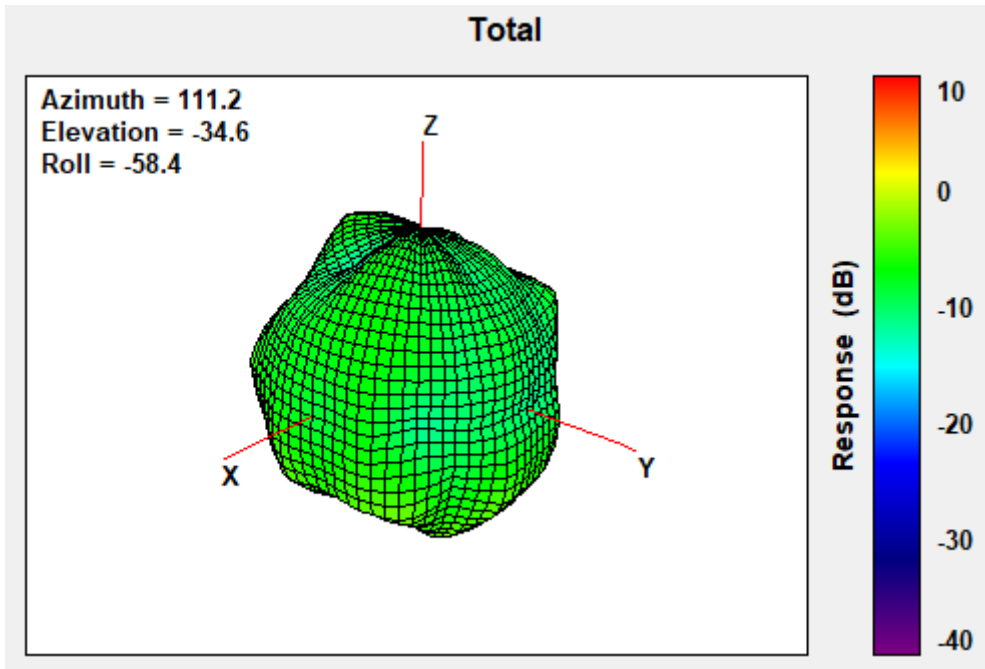

Center Frequency	1880 MHz
Horizontal (dBi) peak	-3.06
Vertical (dBi) peak	-4.37

1910MHz

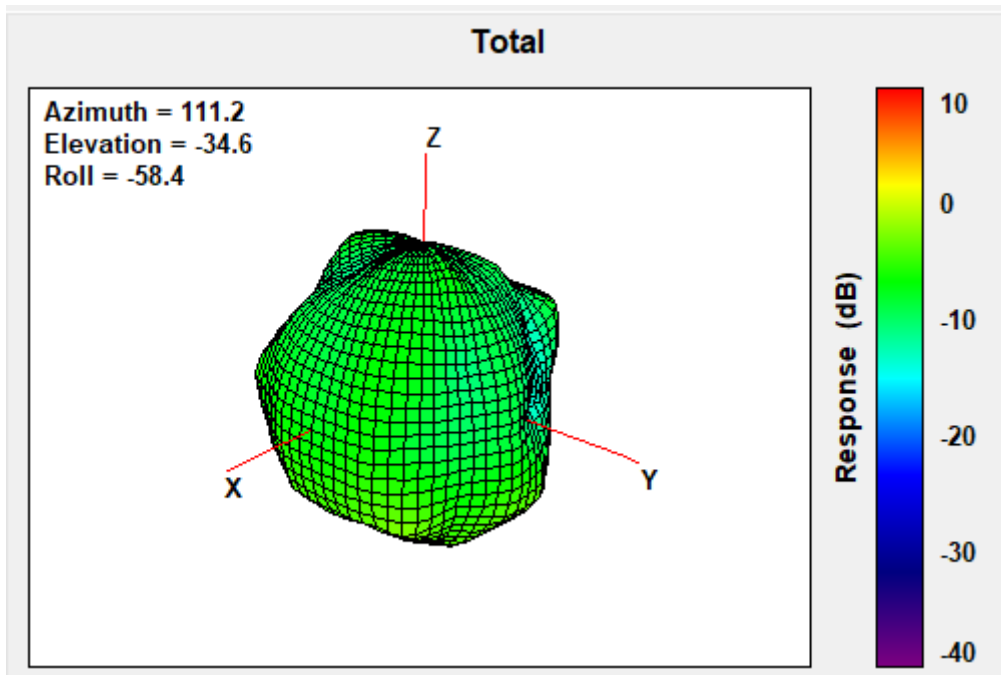

Center Frequency	1910MHz
Horizontal (dBi) peak	-2.52
Vertical (dBi) peak	-5.09

1920MHz

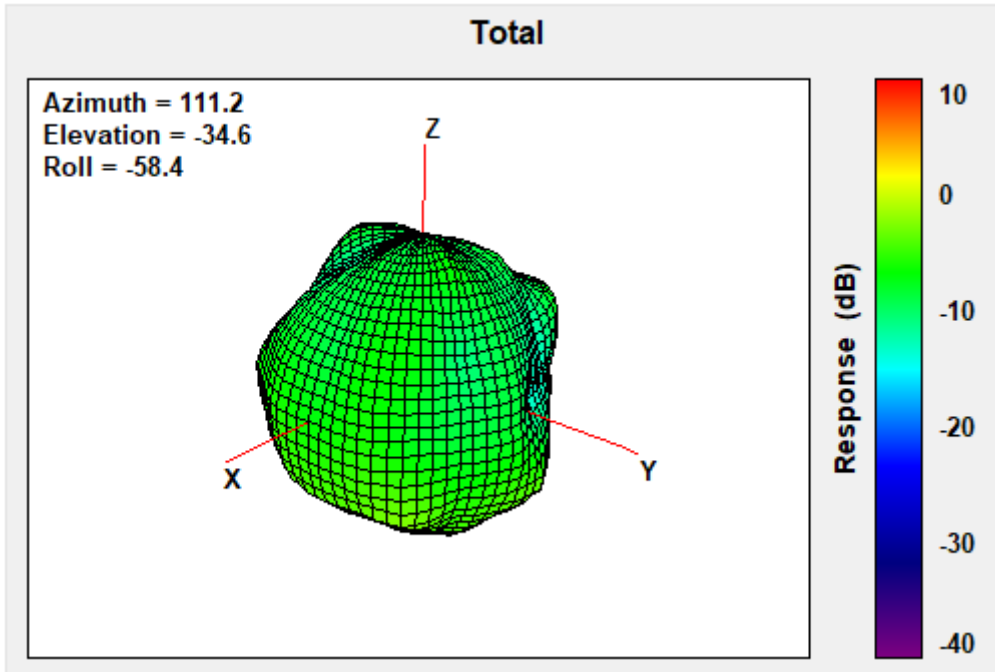

Center Frequency	1920MHz
Horizontal (dBi) peak	-2.51
Vertical (dBi) peak	-5.80

1950MHz

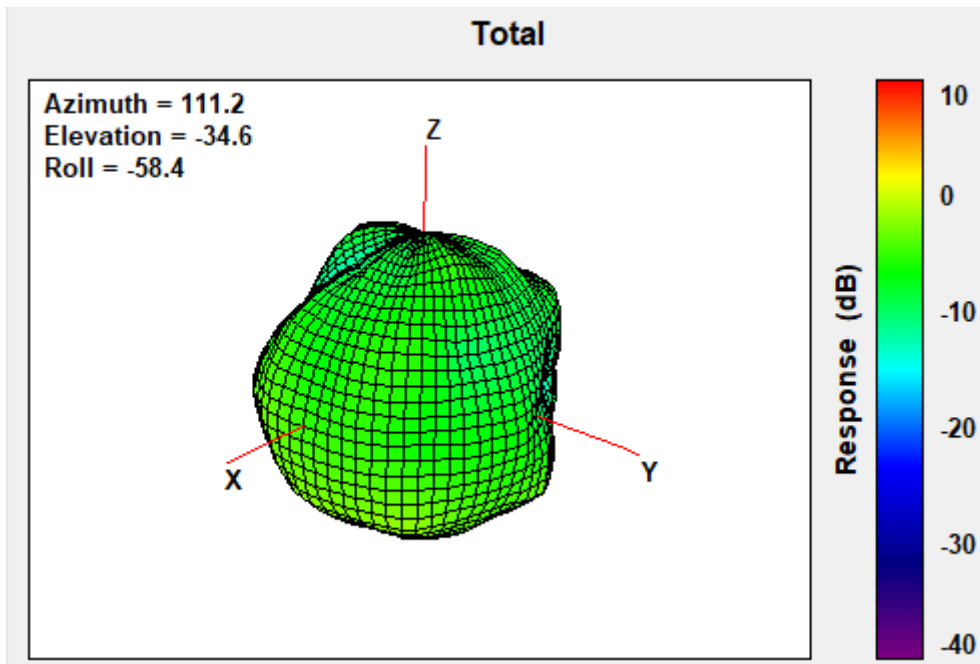

Center Frequency	1950MHz
Horizontal (dBi) peak	-2.06
Vertical (dBi) peak	-4.29

1980MHz

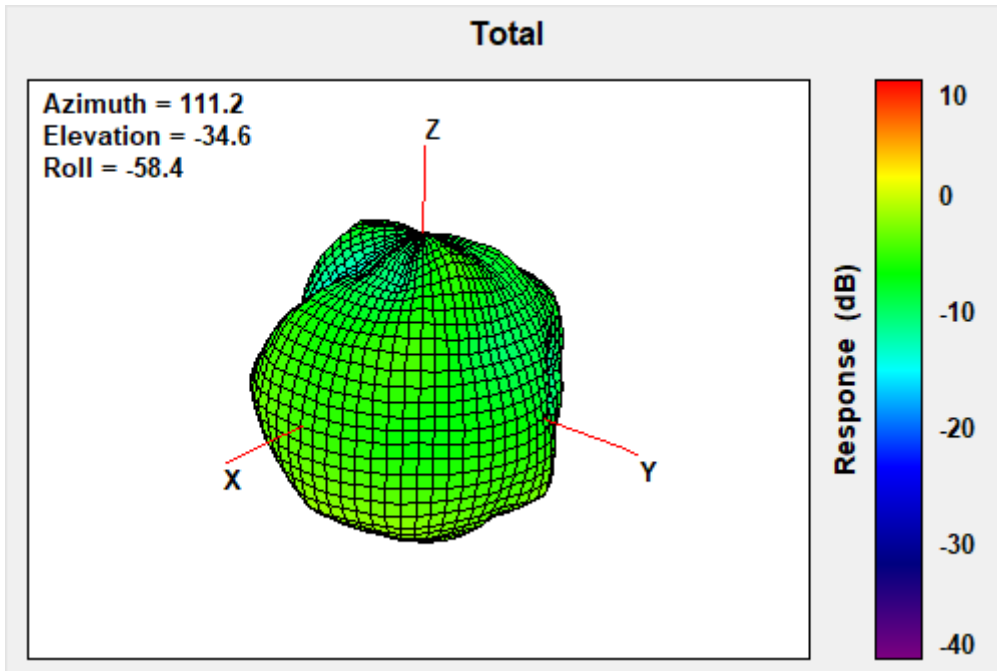

2110MHz

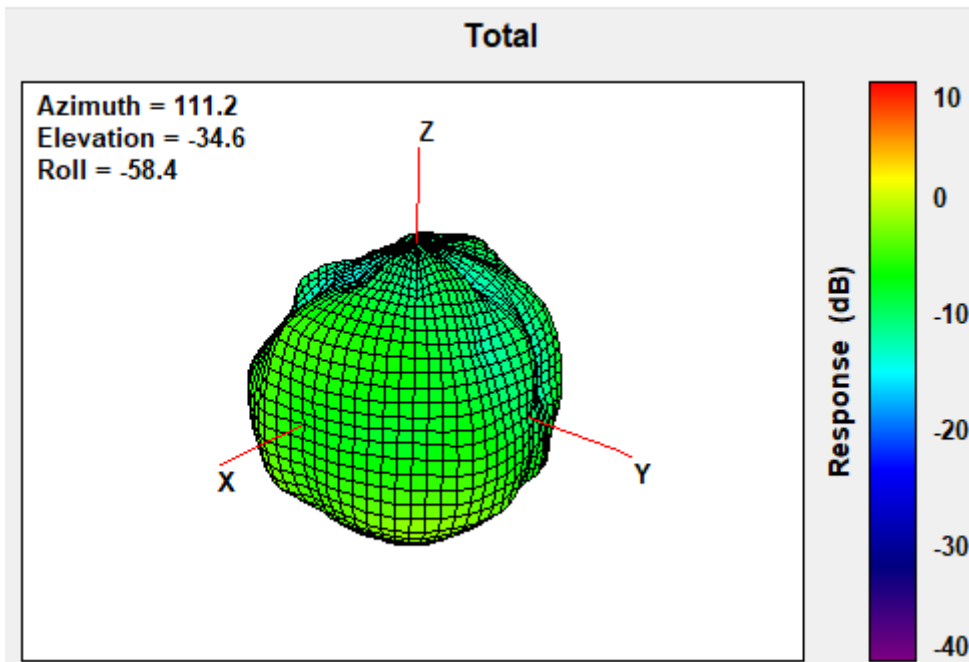

2200MHz

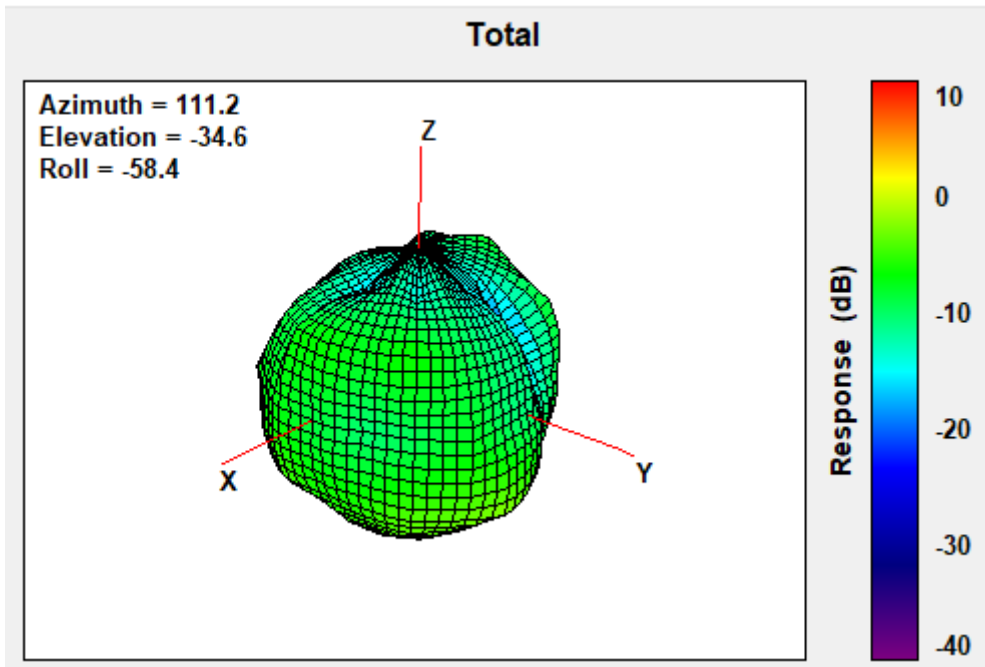

Center Frequency	2200MHz
Horizontal (dBi) peak	-2.84
Vertical (dBi) peak	-4.64

2300MHz

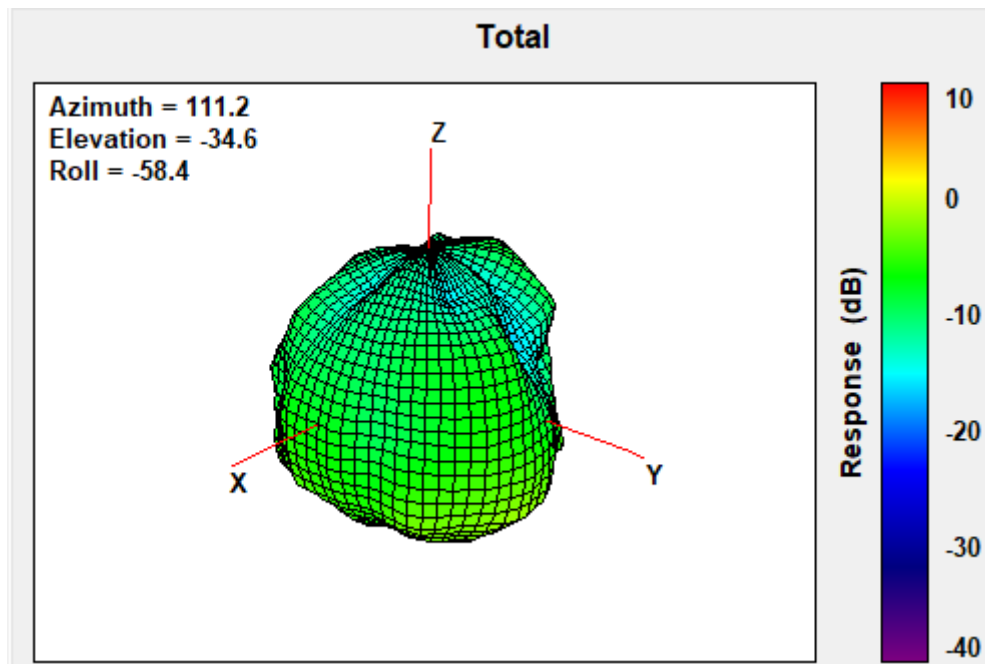

Center Frequency	2300MHz
Horizontal (dBi) peak	-2.15
Vertical (dBi) peak	-3.18

2305MHz

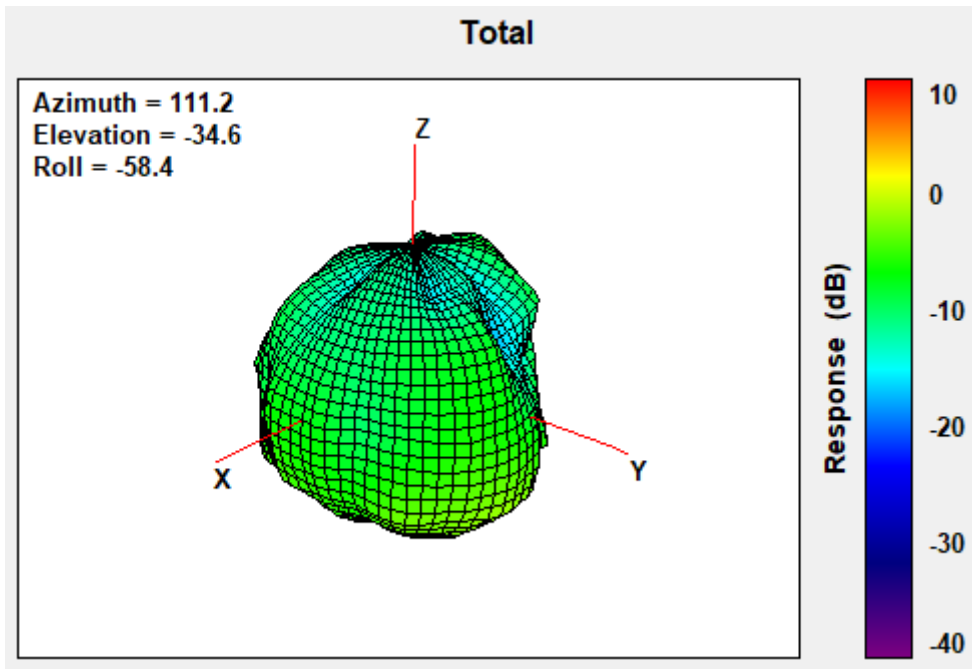

Center Frequency	2305MHz
Horizontal (dBi) peak	-2.16
Vertical (dBi) peak	-3.17

2315MHz

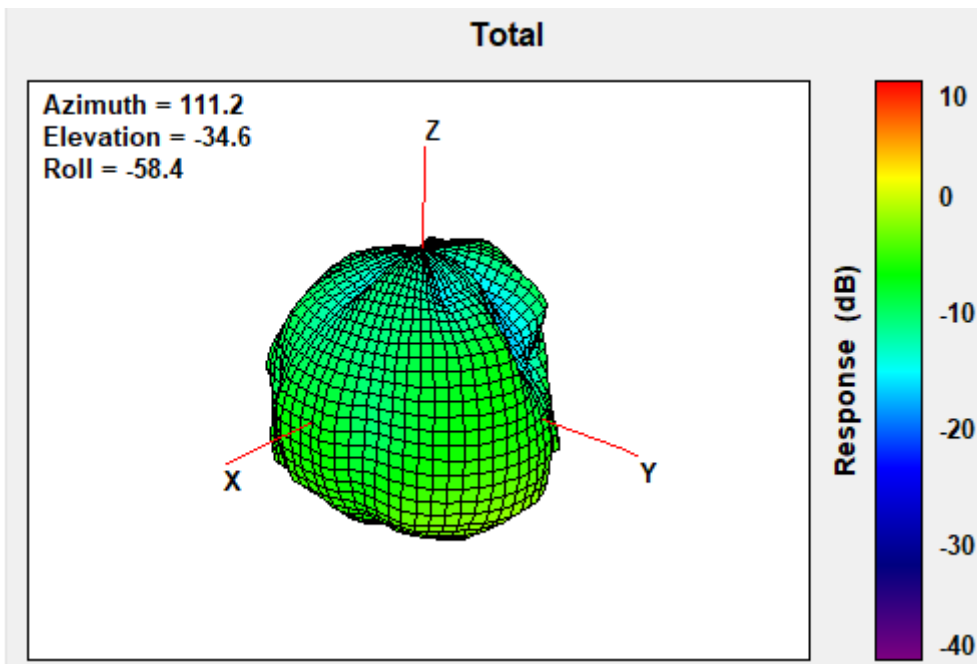

Center Frequency	2315MHz
Horizontal (dBi) peak	-1.98
Vertical (dBi) peak	-3.15

2350MHz

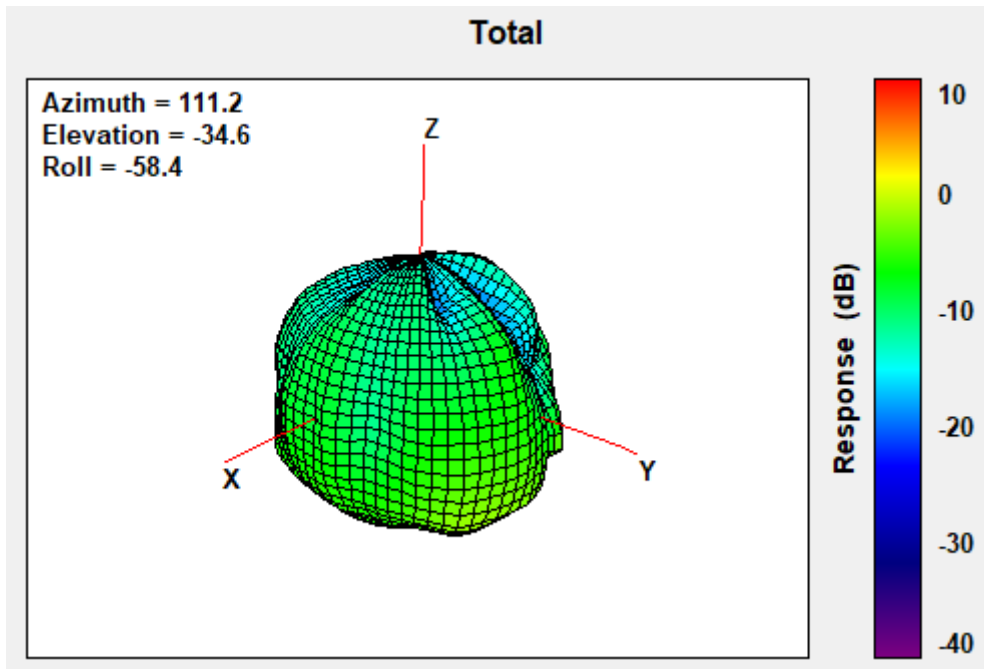

Center Frequency	2350MHz
Horizontal (dBi) peak	-1.57
Vertical (dBi) peak	-3.45

2400MHz

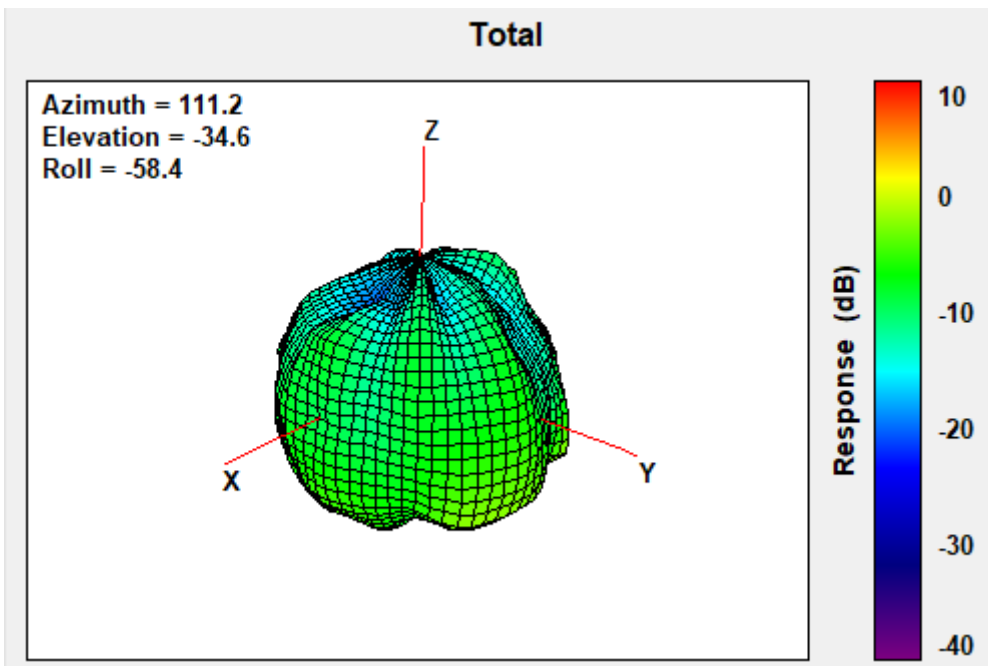

Center Frequency	2400MHz
Horizontal (dBi) peak	-0.41
Vertical (dBi) peak	-1.52

2500MHz

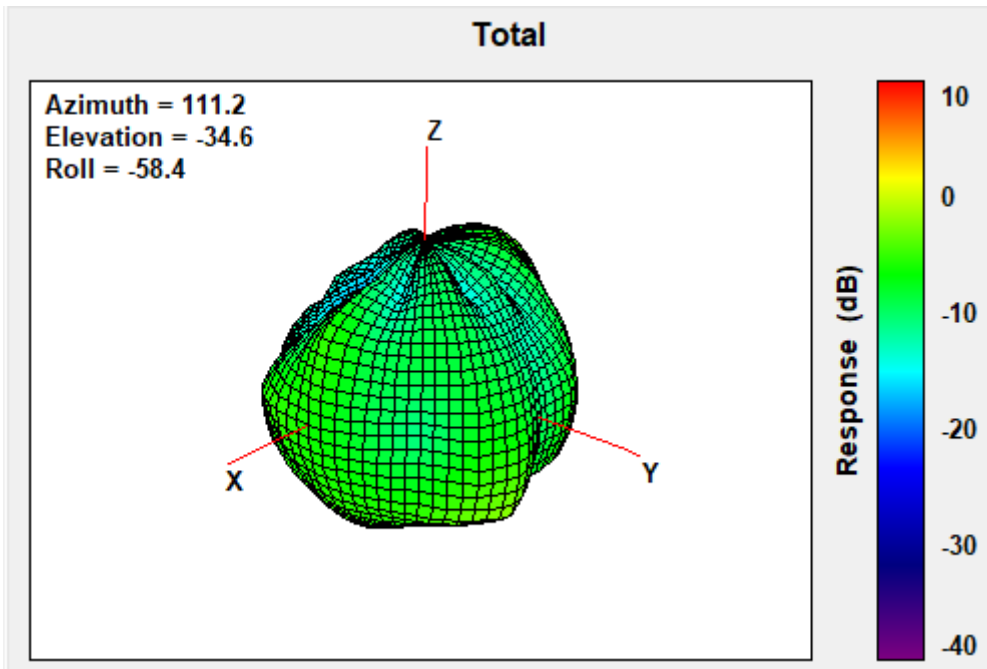

Center Frequency	2500MHz
Horizontal (dBi) peak	-1.72
Vertical (dBi) peak	-2.58

2570MHz

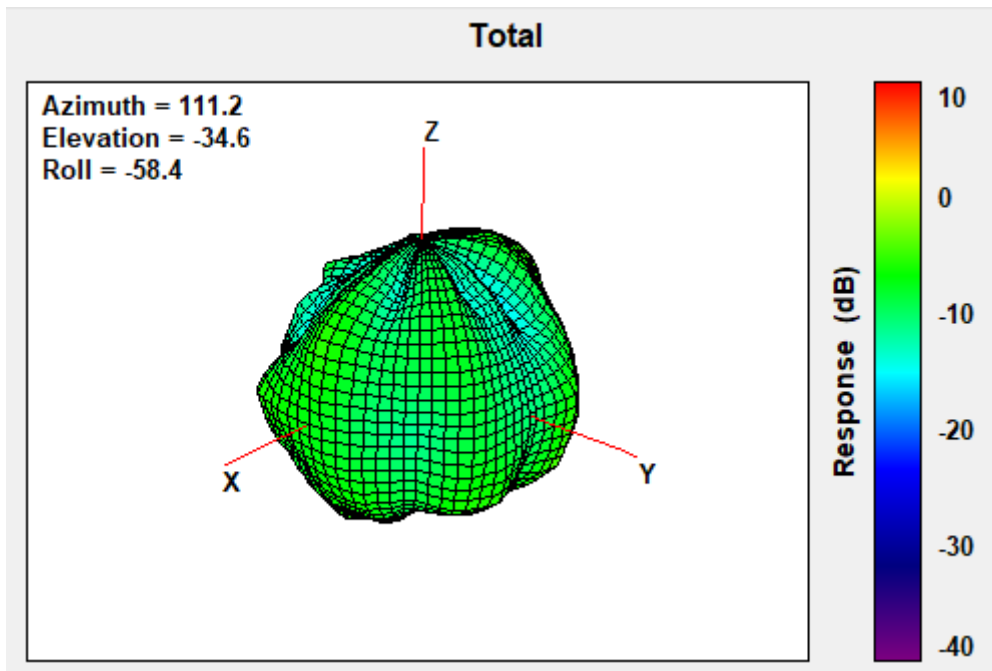

Center Frequency	2570MHz
Horizontal (dBi) peak	-0.55
Vertical (dBi) peak	-1.09

2595MHz

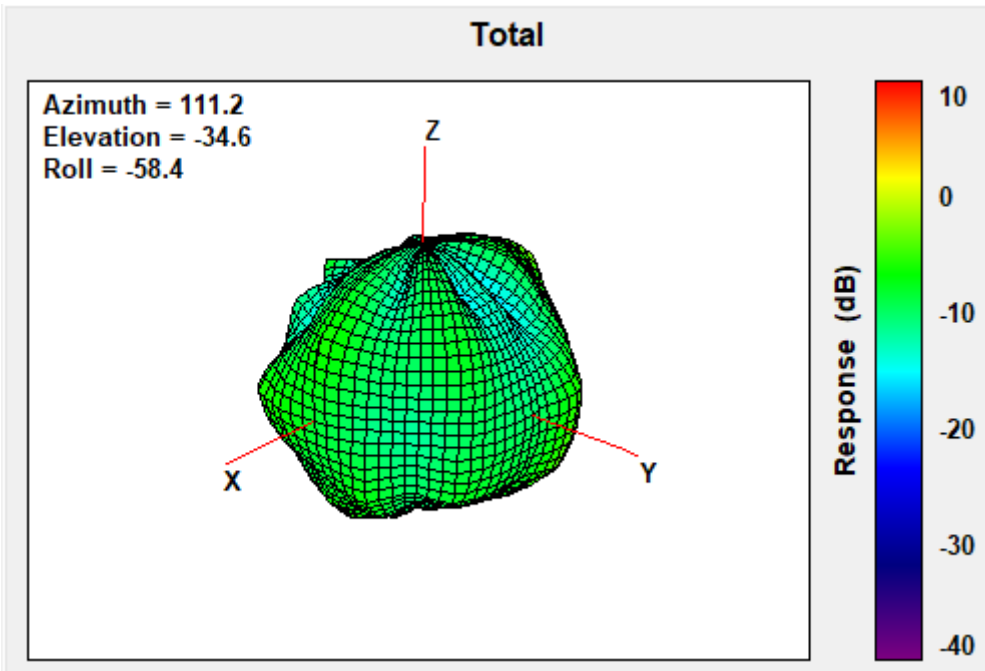

Center Frequency	2595MHz
Horizontal (dBi) peak	0.25
Vertical (dBi) peak	-0.83

2620MHz

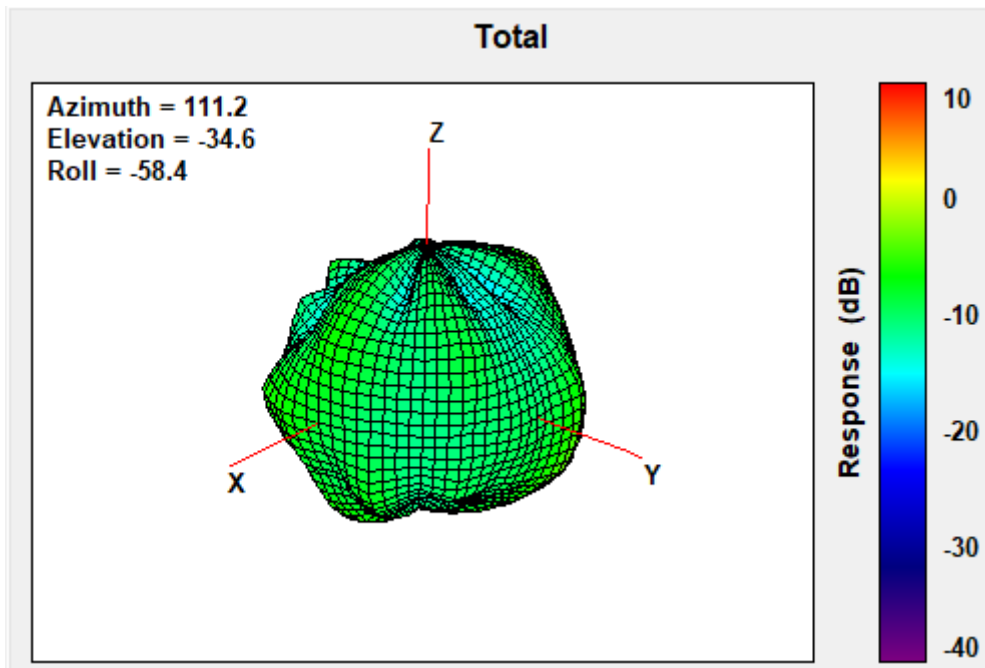

Center Frequency	2620MHz
Horizontal (dBi) peak	-0.30
Vertical (dBi) peak	-0.67

2690MHz

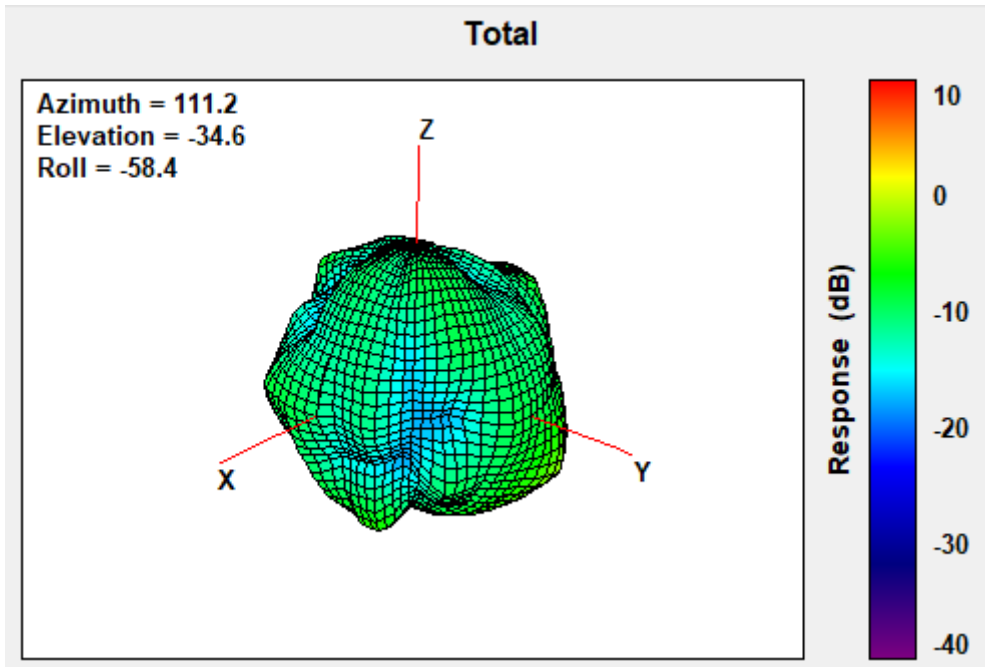

Center Frequency	2690MHz
Horizontal (dBi) peak	-0.87
Vertical (dBi) peak	-2.67

3400MHz

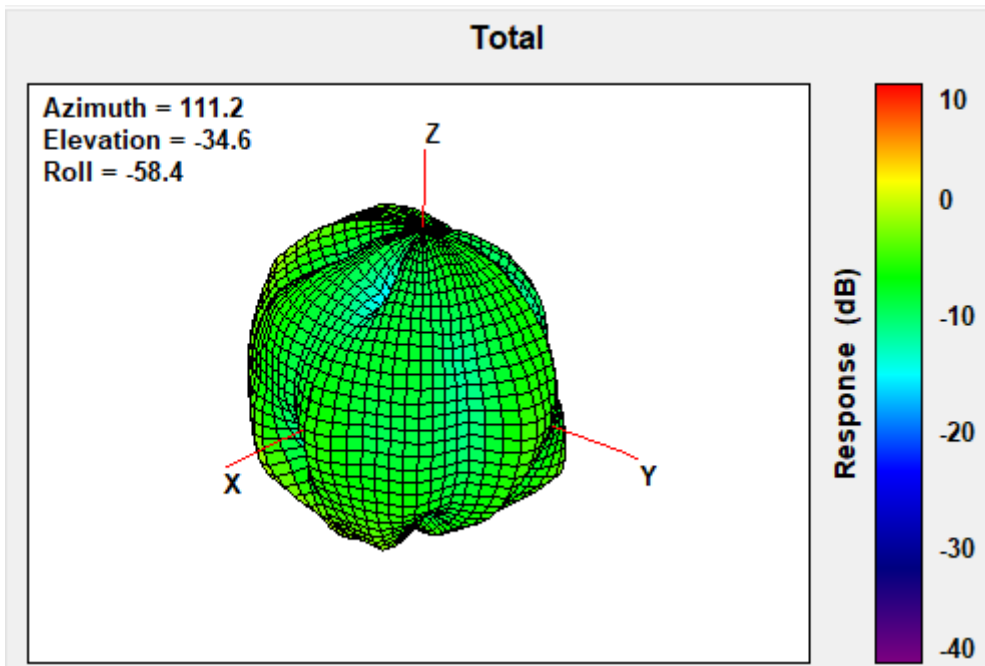

Center Frequency	3400MHz
Horizontal (dBi) peak	-0.77
Vertical (dBi) peak	0.13

3500MHz

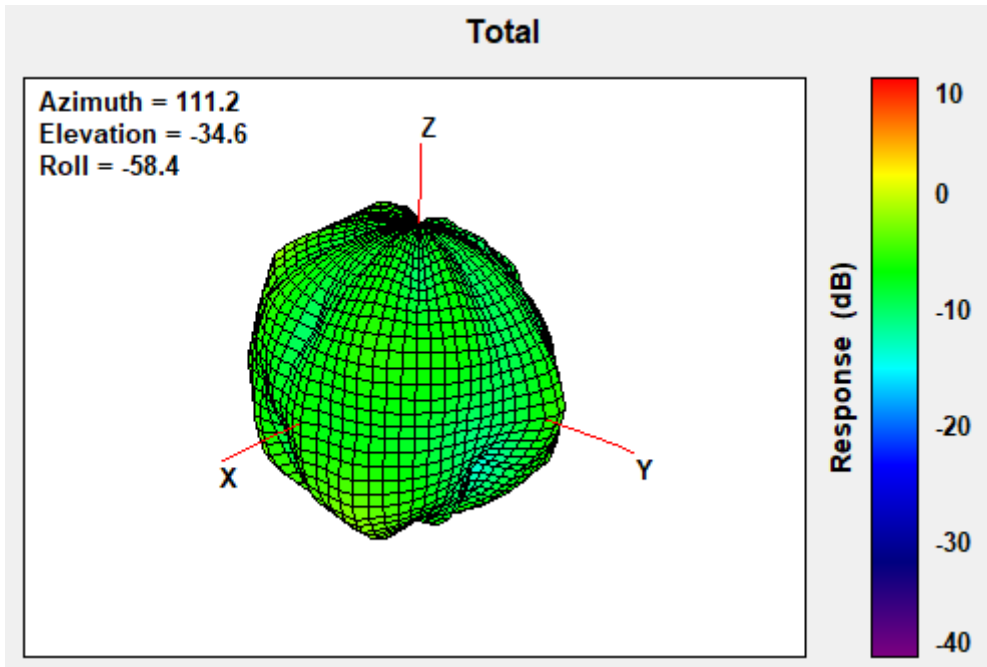

Center Frequency	3500MHz
Horizontal (dBi) peak	-0.12
Vertical (dBi) peak	0.37

3600MHz

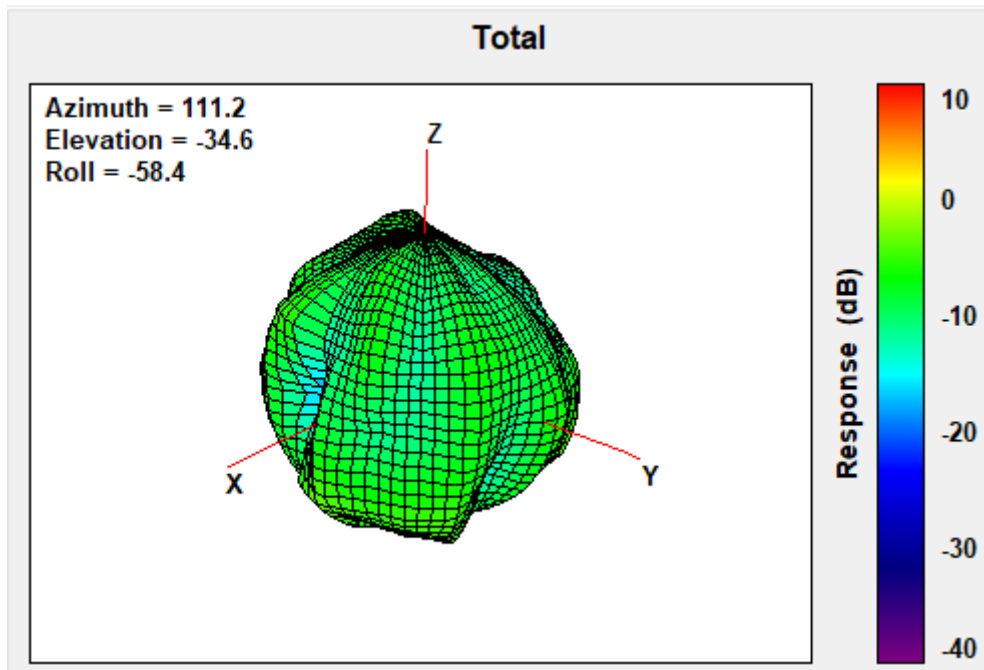

Center Frequency	3600MHz
Horizontal (dBi) peak	-1.58
Vertical (dBi) peak	-1.64

3700MHz

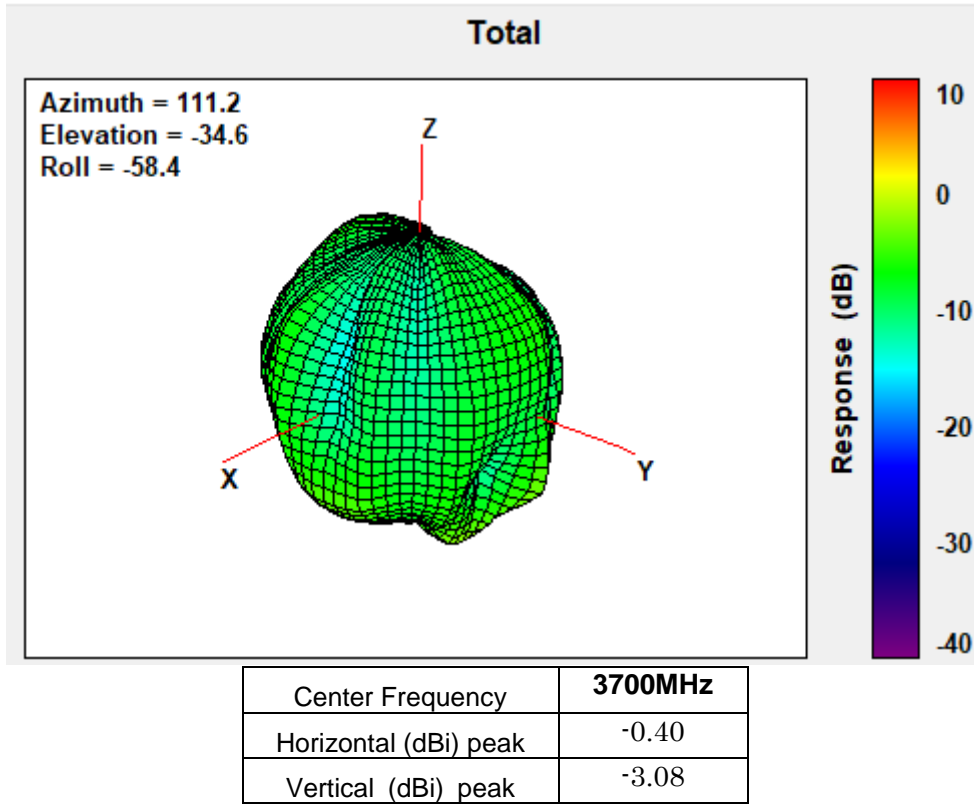

3800MHz

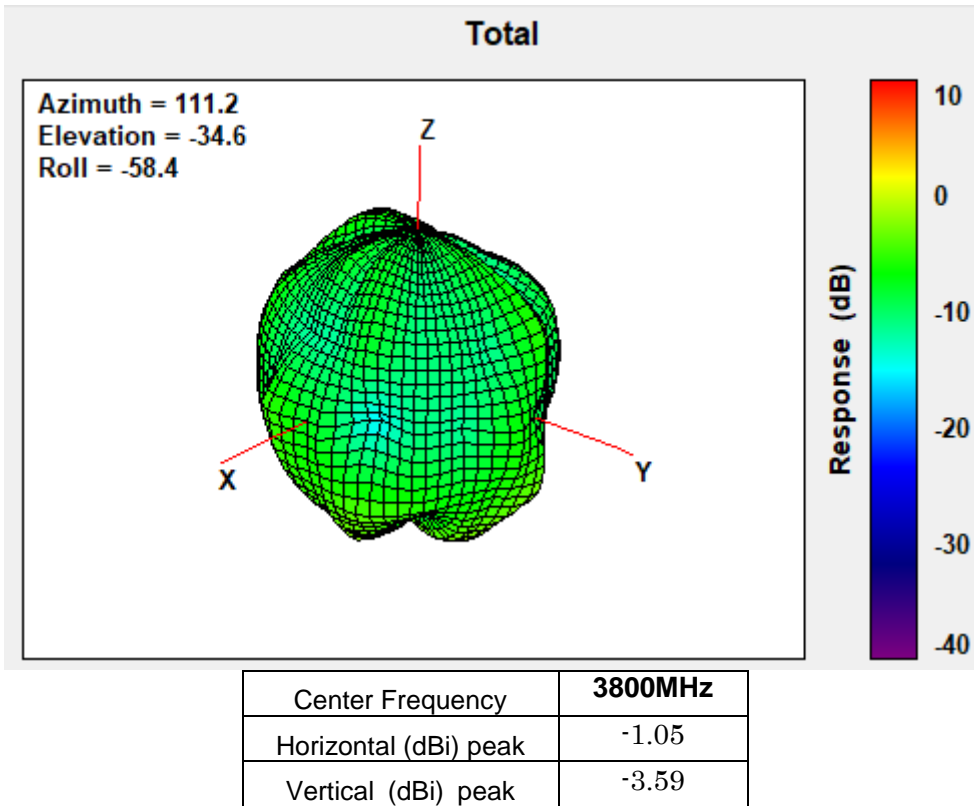

4200MHz

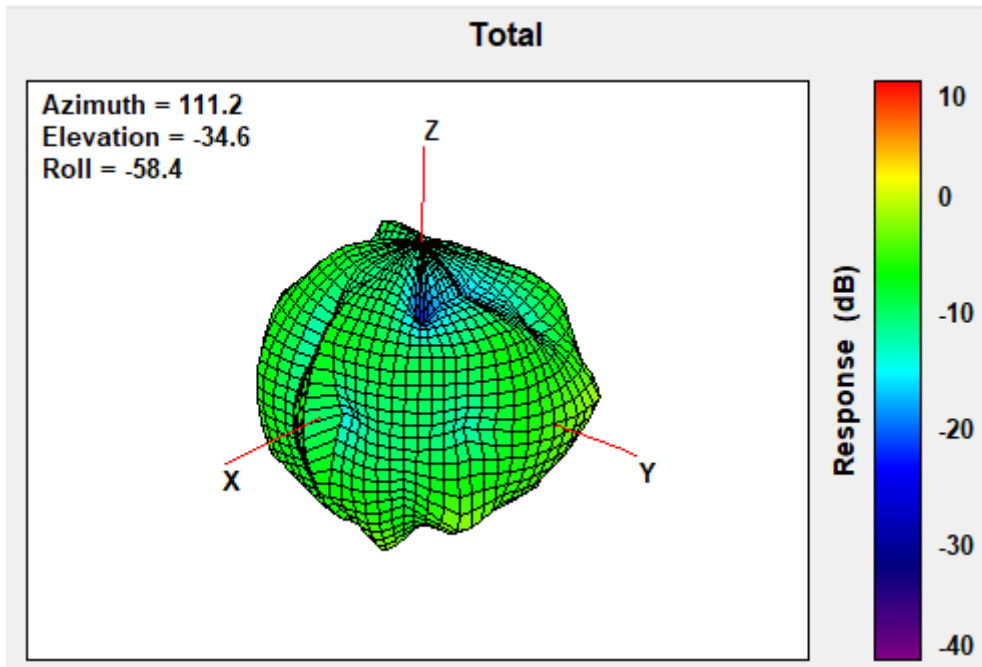

Center Frequency	4200MHz
Horizontal (dBi) peak	0.32
Vertical (dBi) peak	-1.46

4400MHz

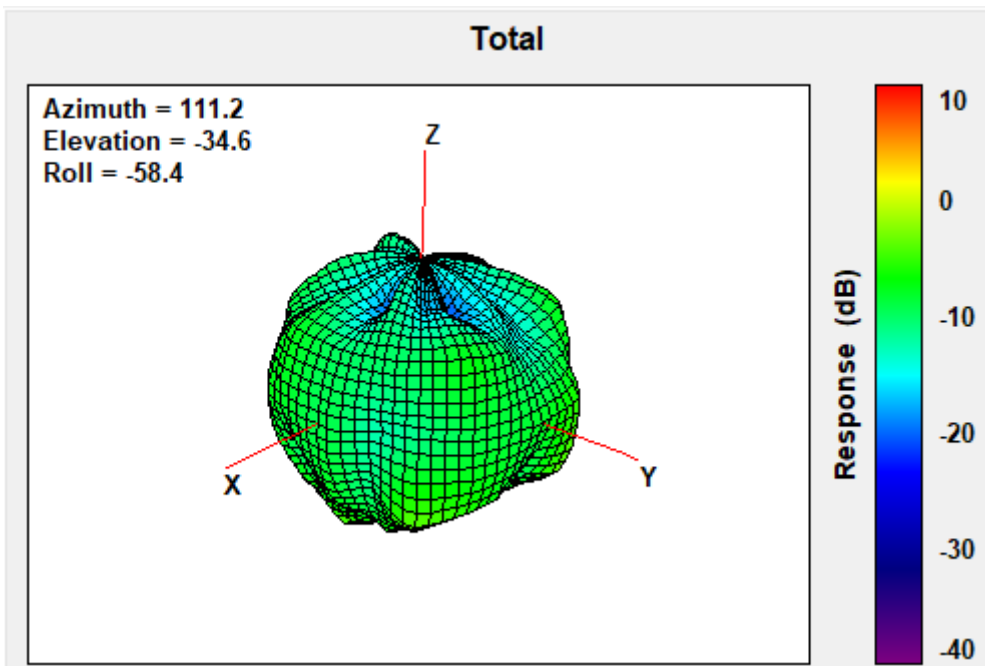

Center Frequency	4400MHz
Horizontal (dBi) peak	0.19
Vertical (dBi) peak	-2.14

4700MHz

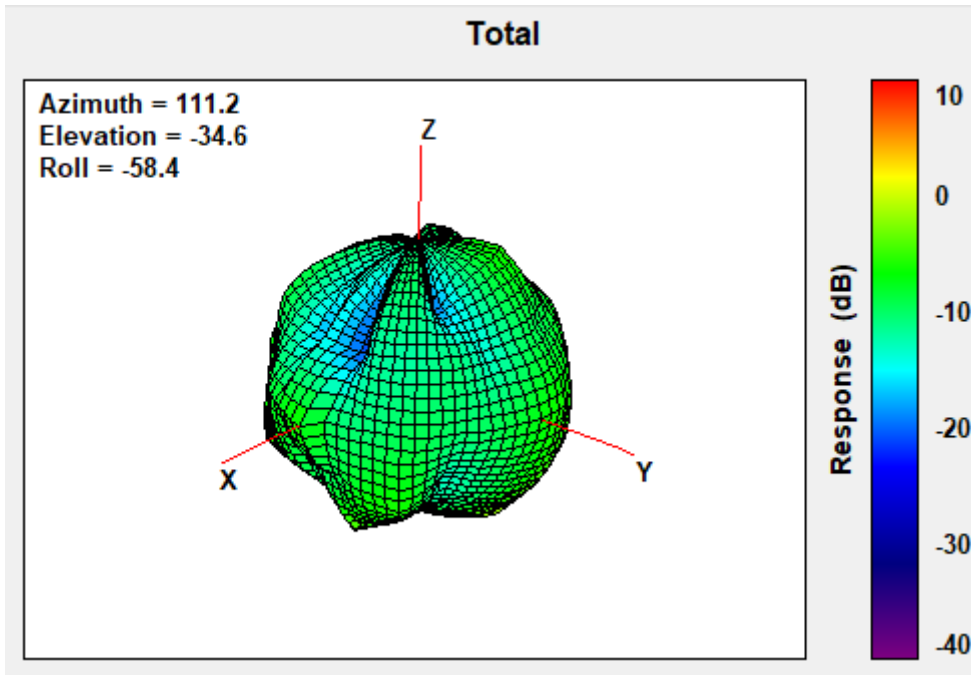

Center Frequency	4700MHz
Horizontal (dBi) peak	-1.18
Vertical (dBi) peak	-0.79

5150MHz

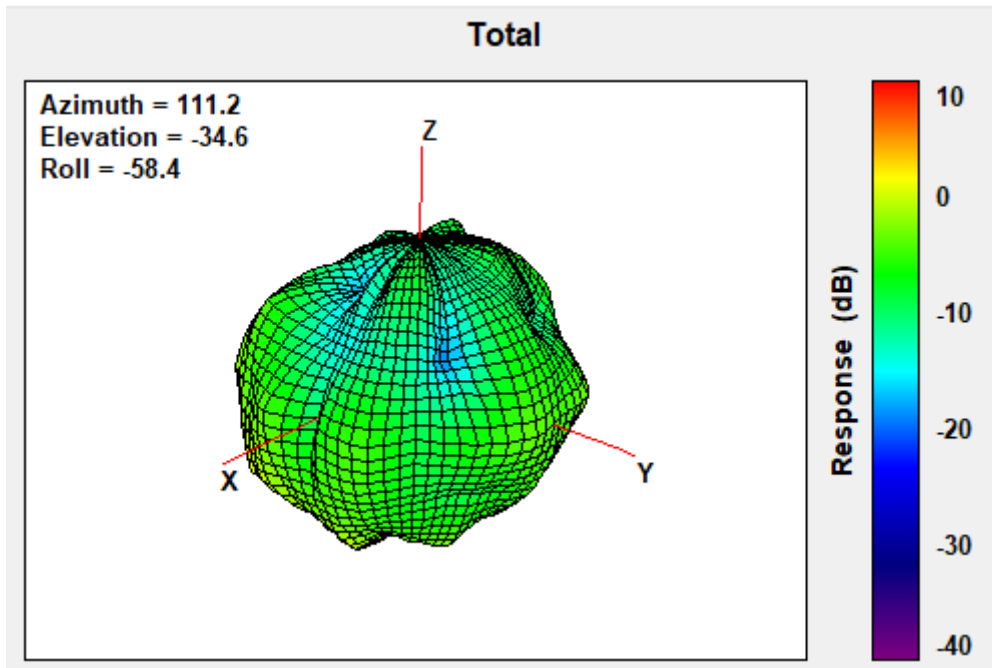

Center Frequency	5150MHz
Horizontal (dBi) peak	0.10
Vertical (dBi) peak	0.99

5537.5MHz

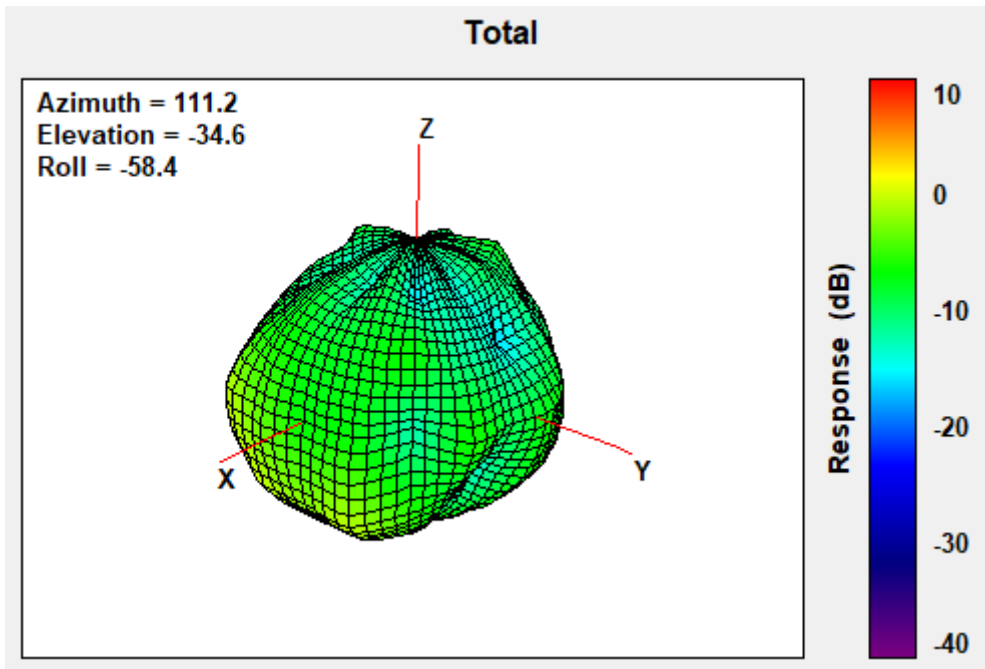

5925MHz

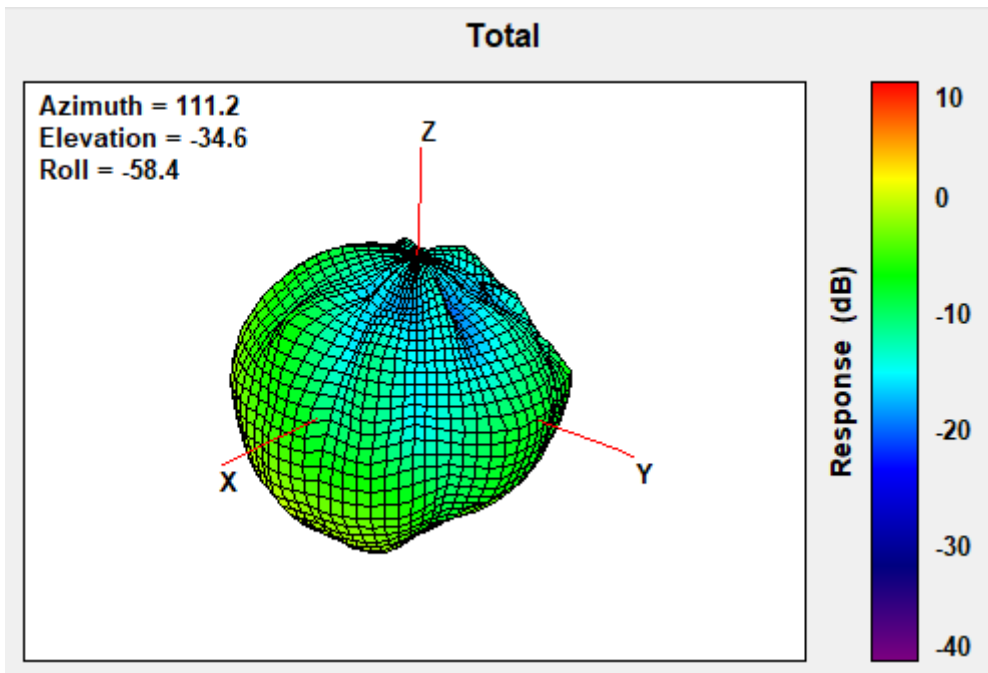

TB mode

WWAN Aux Antenna (Rx2)

617MHz

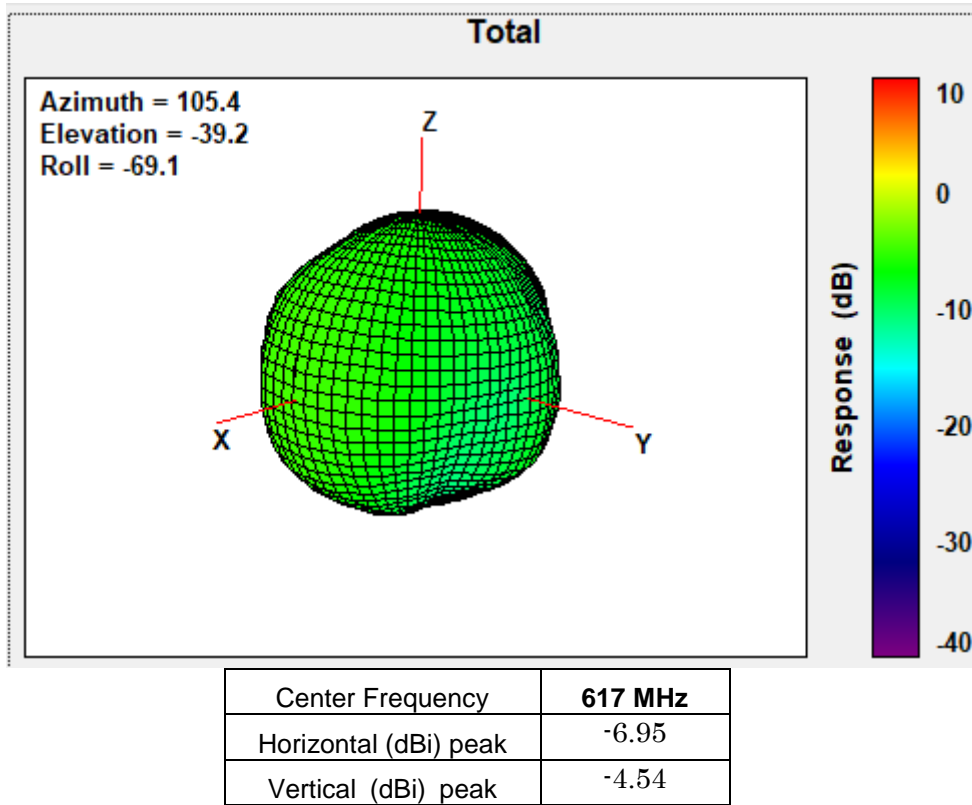

635MHz

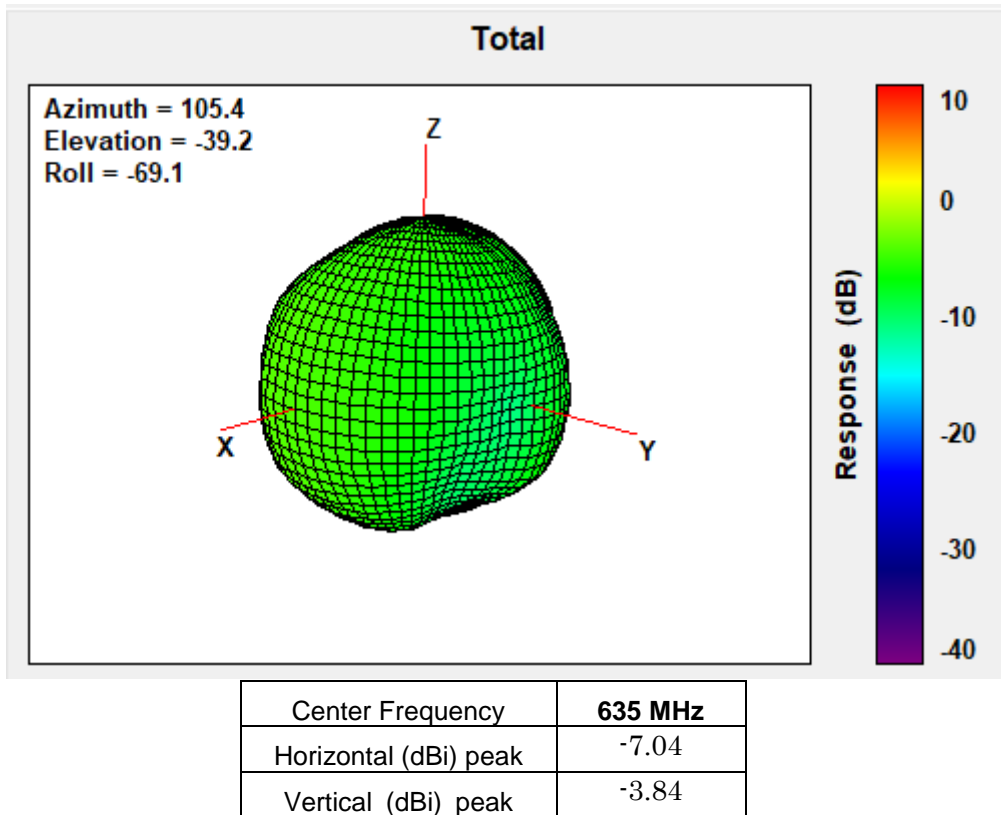

652MHz

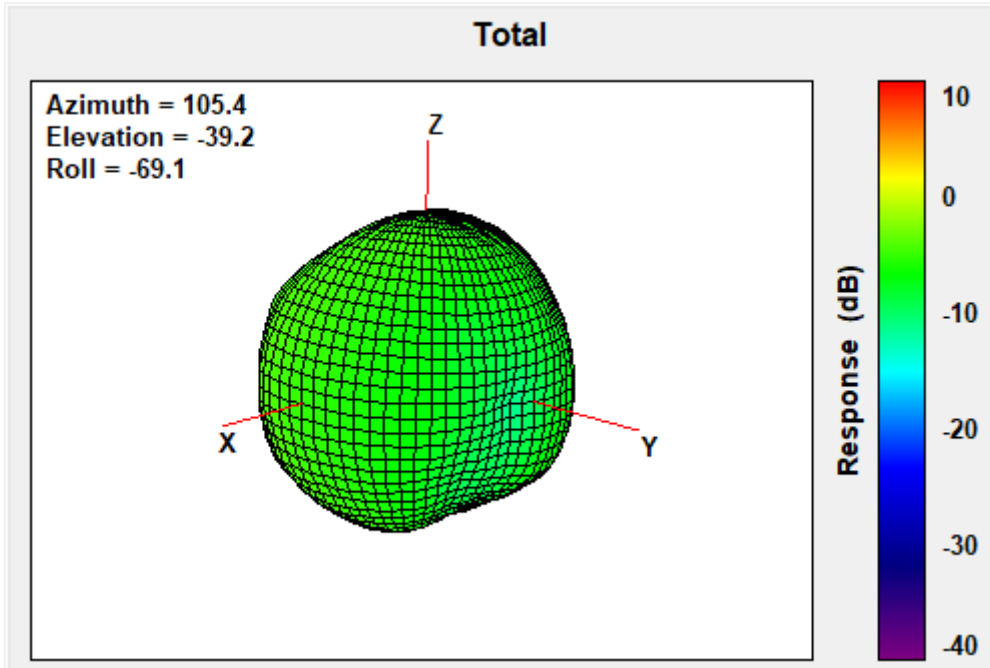

Center Frequency	652MHz
Horizontal (dBi) peak	-6.16
Vertical (dBi) peak	-4.07

663MHz

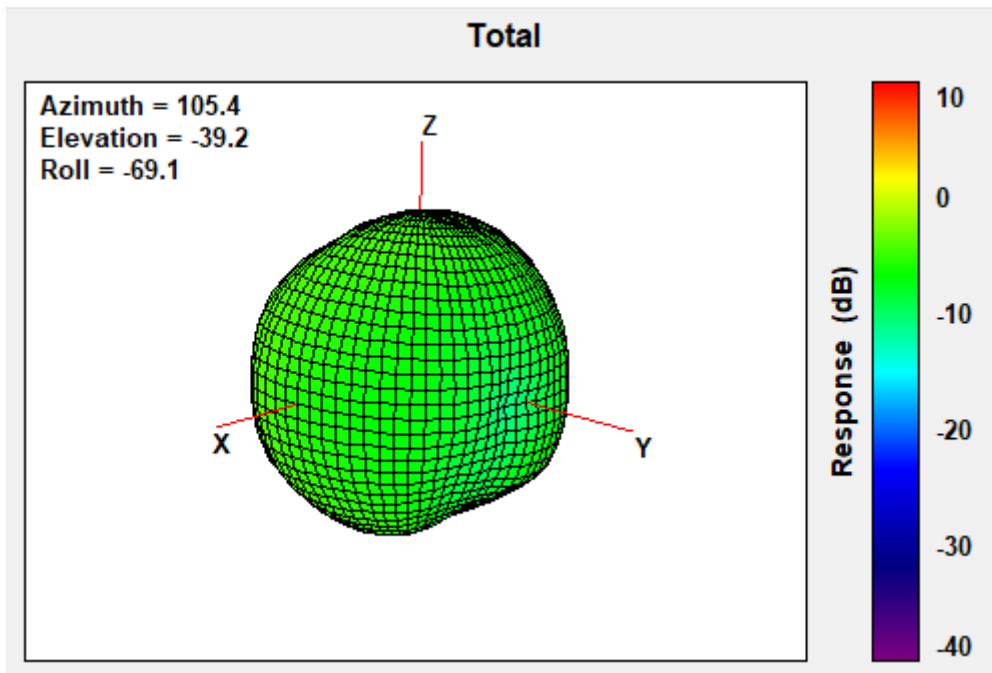

Center Frequency	663 MHz
Horizontal (dBi) peak	-5.80
Vertical (dBi) peak	-4.20

681MHz

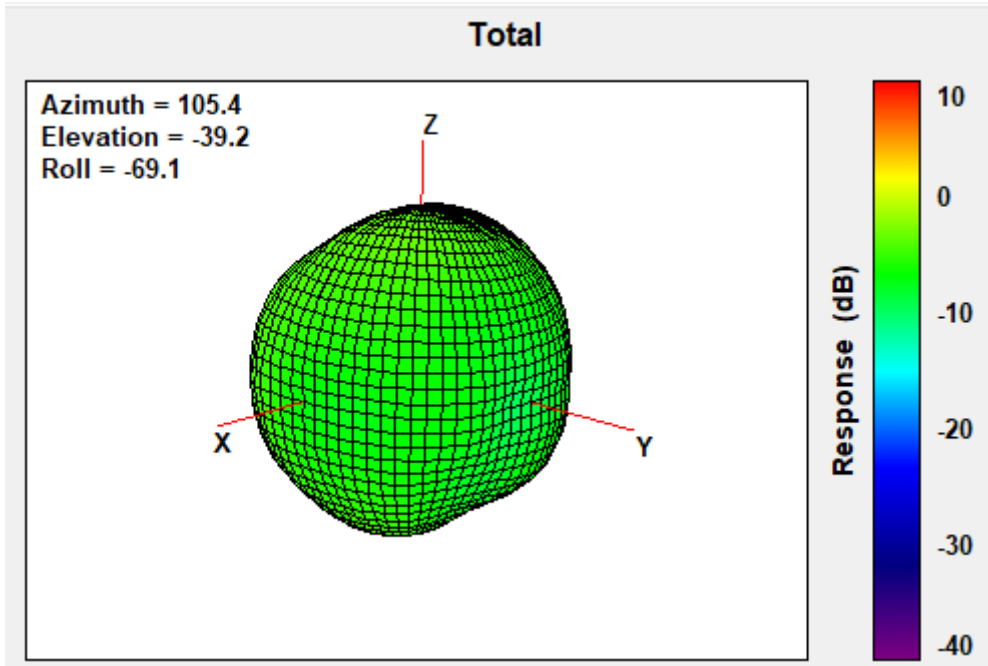

Center Frequency	681MHz
Horizontal (dBi) peak	-5.64
Vertical (dBi) peak	-3.52

698MHz

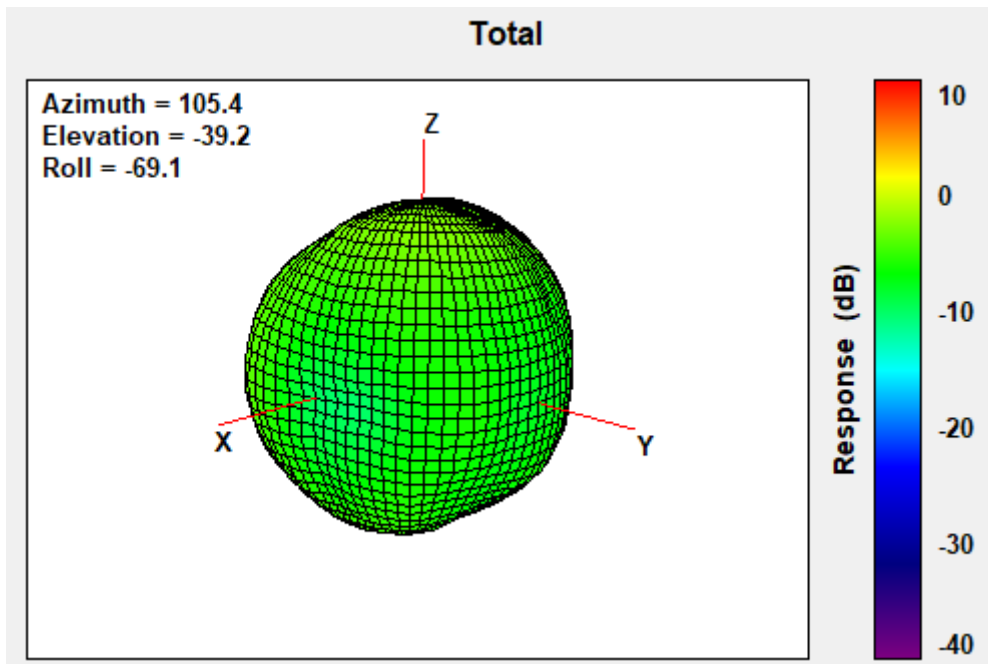

Center Frequency	698MHz
Horizontal (dBi) peak	-4.48
Vertical (dBi) peak	-2.51

703MHz

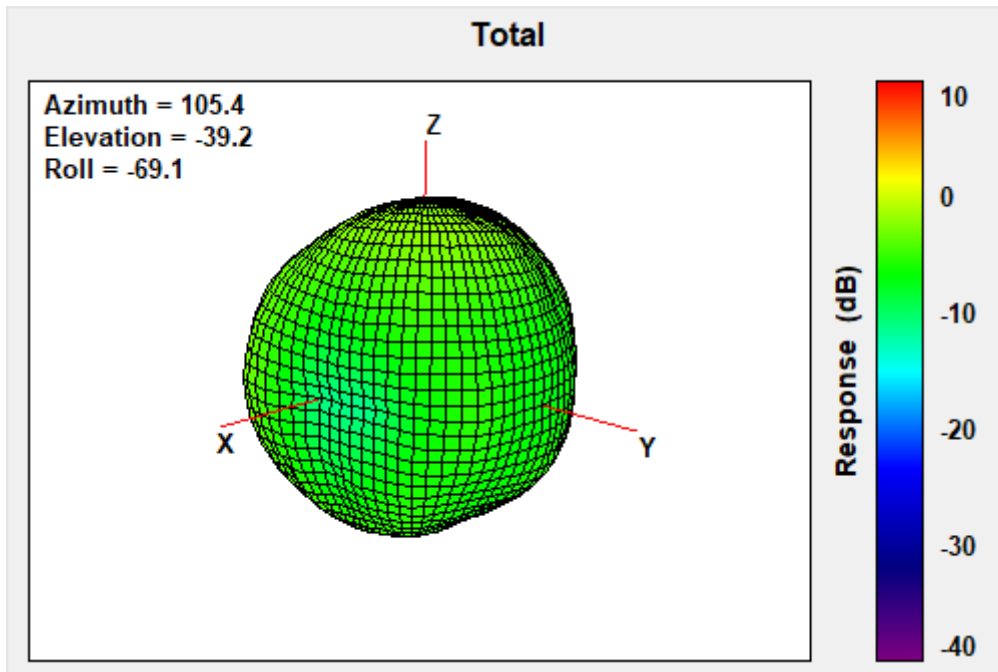

Center Frequency	703 MHz
Horizontal (dBi) peak	-3.68
Vertical (dBi) peak	-2.02

707.5MHz

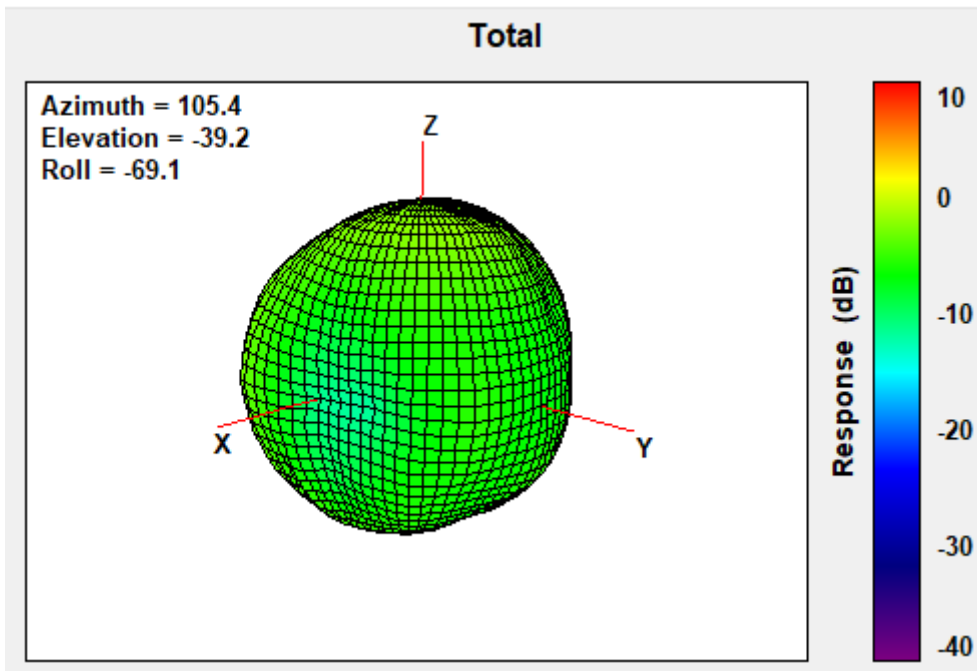

Center Frequency	707.5MHz
Horizontal (dBi) peak	-3.56
Vertical (dBi) peak	-2.05

717MHz

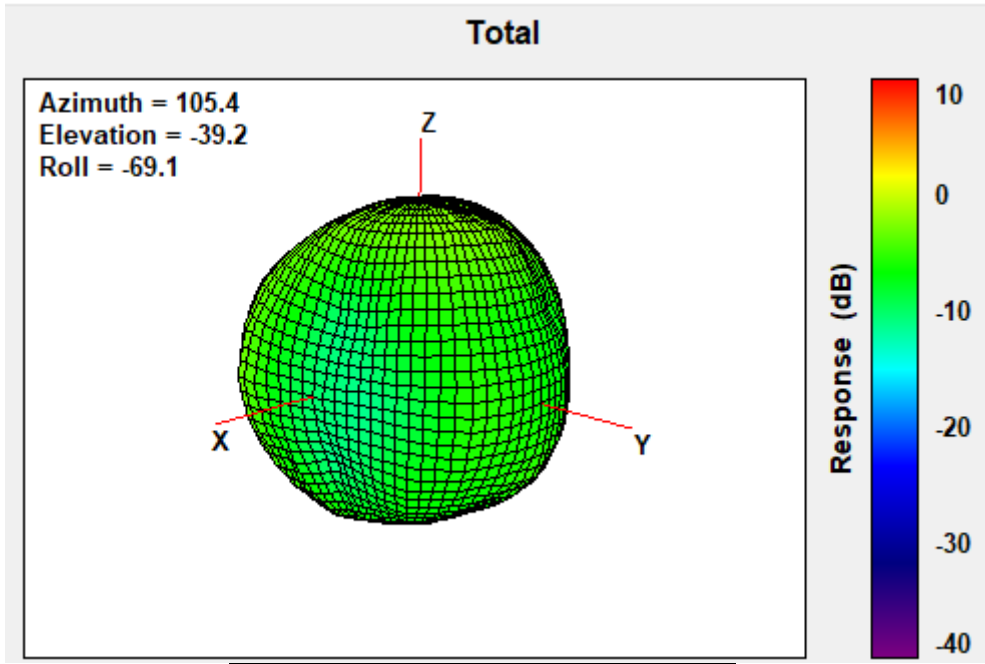

Center Frequency	717MHz
Horizontal (dBi) peak	-3.72
Vertical (dBi) peak	-3.70

725.5MHz

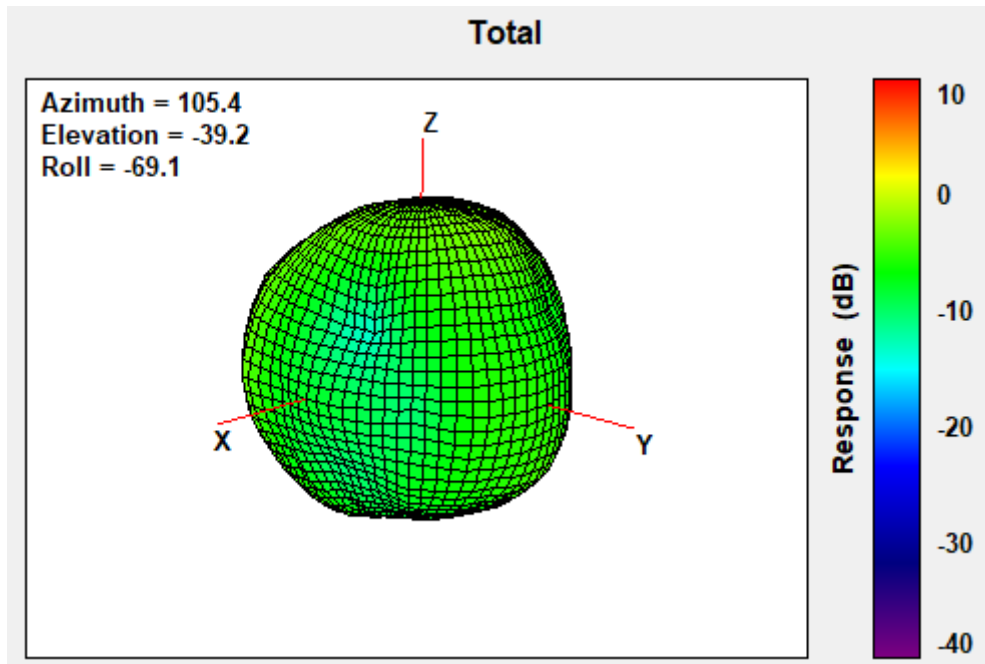

Center Frequency	725.5MHz
Horizontal (dBi) peak	-3.69
Vertical (dBi) peak	-3.87

748MHz

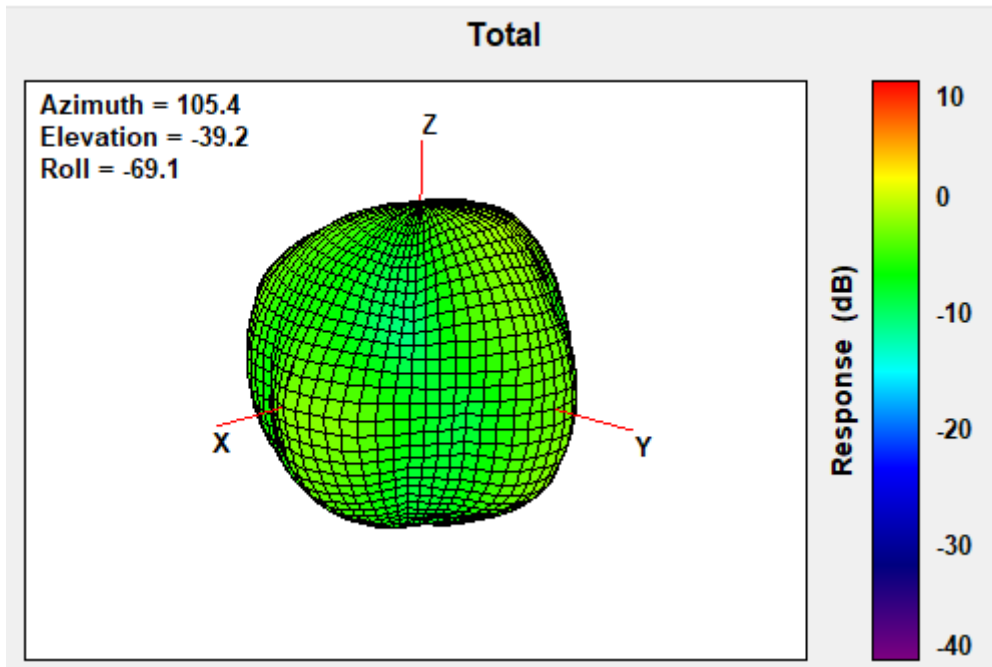

Center Frequency	748MHz
Horizontal (dBi) peak	-4.20
Vertical (dBi) peak	-3.92

756MHz

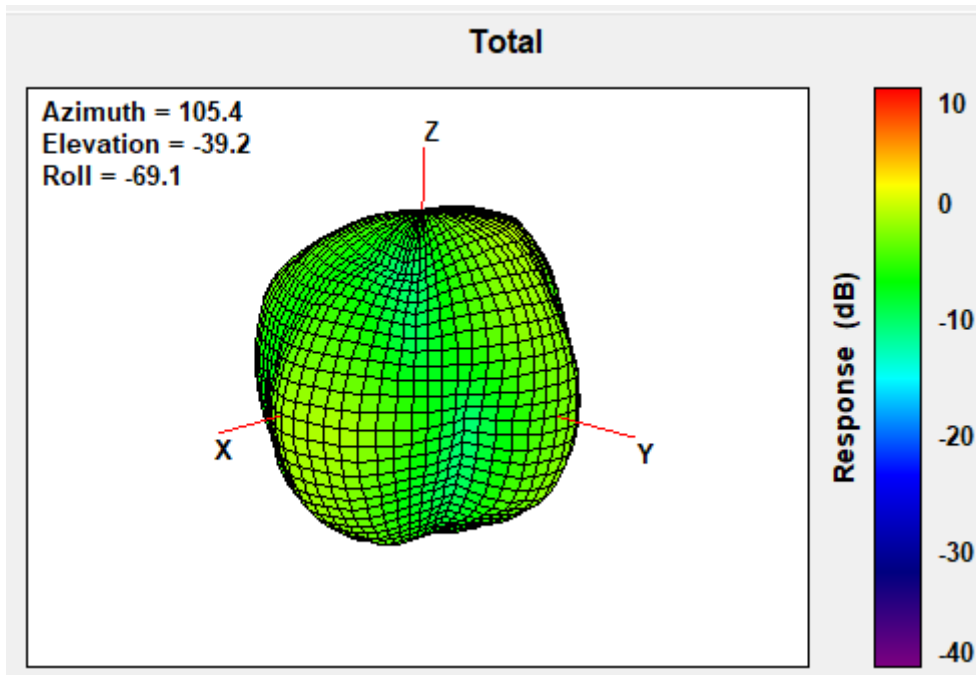

Center Frequency	756MHz
Horizontal (dBi) peak	-4.01
Vertical (dBi) peak	-4.16

768MHz

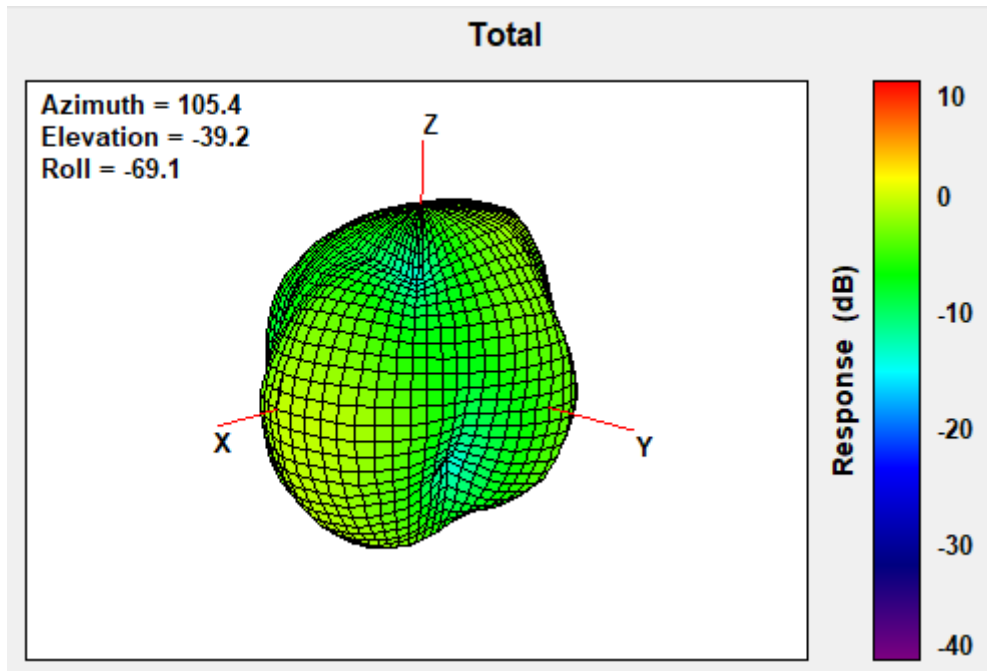

Center Frequency	768MHz
Horizontal (dBi) peak	-3.74
Vertical (dBi) peak	-4.21

777MHz

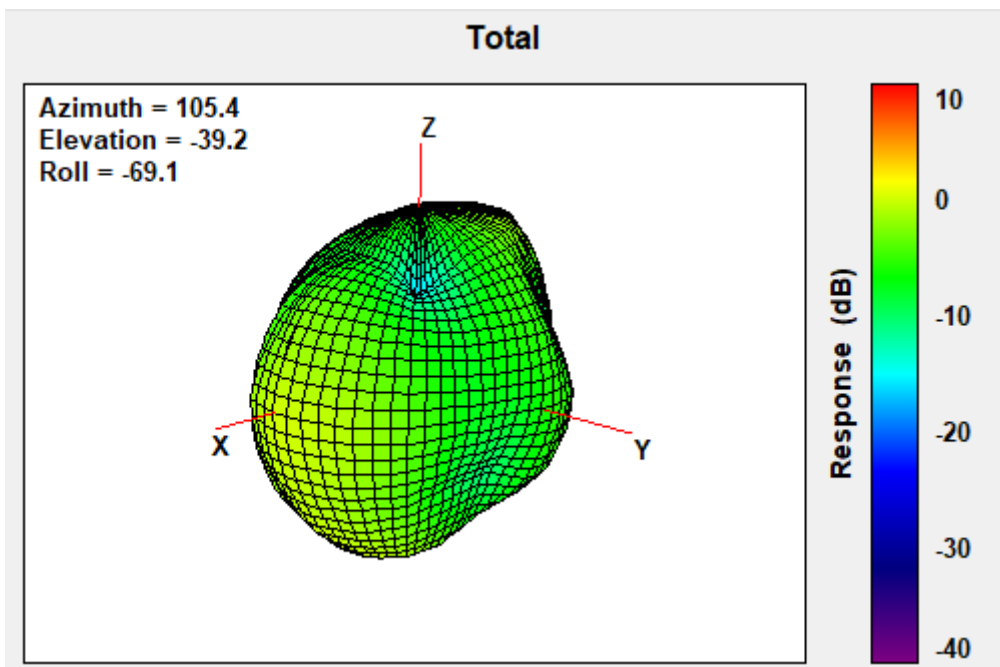

Center Frequency	777MHz
Horizontal (dBi) peak	-3.86
Vertical (dBi) peak	-3.79

782MHz

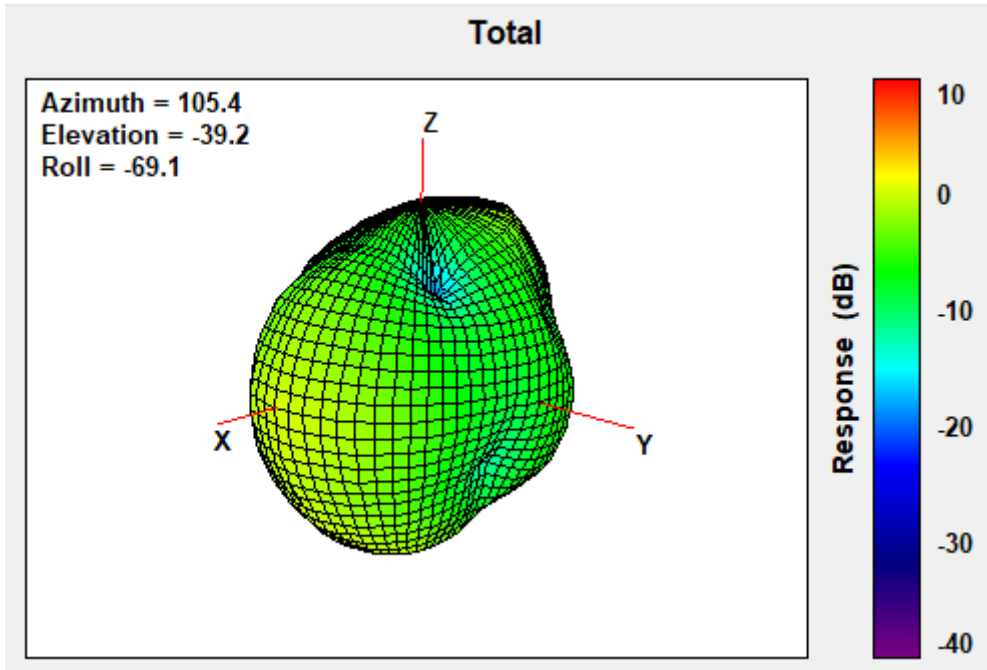

Center Frequency	782MHz
Horizontal (dBi) peak	-3.93
Vertical (dBi) peak	-3.65

787MHz

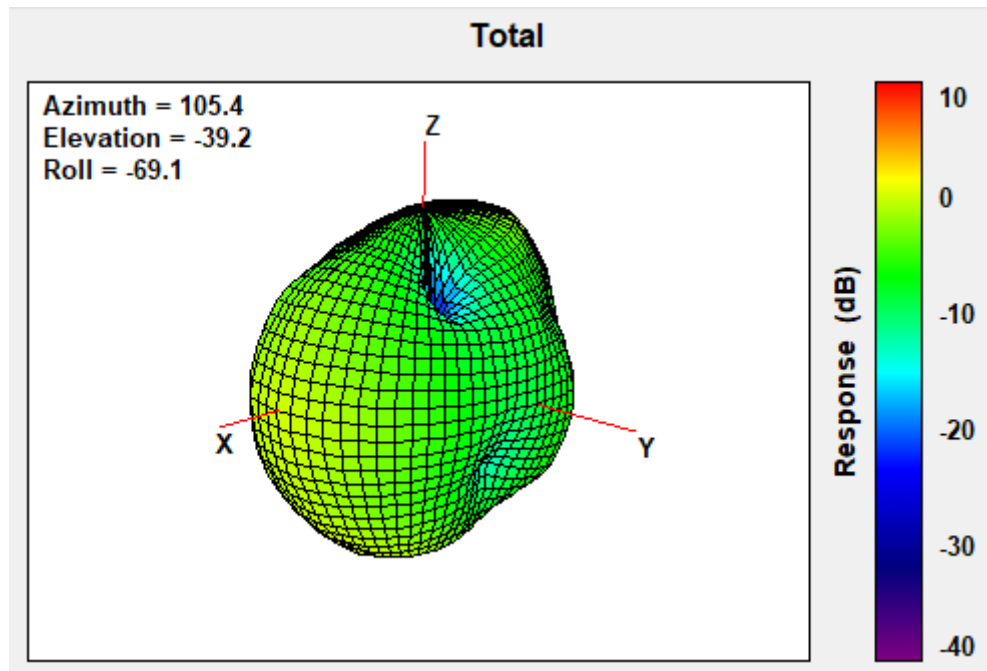

Center Frequency	787MHz
Horizontal (dBi) peak	-3.66
Vertical (dBi) peak	-3.71

814MHz

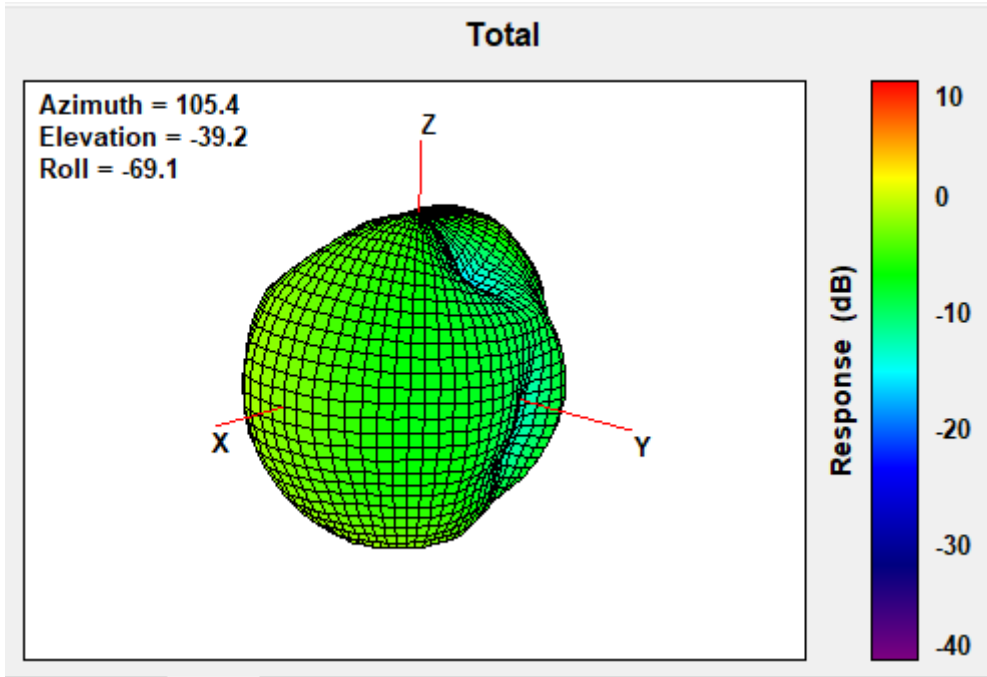

824MHz

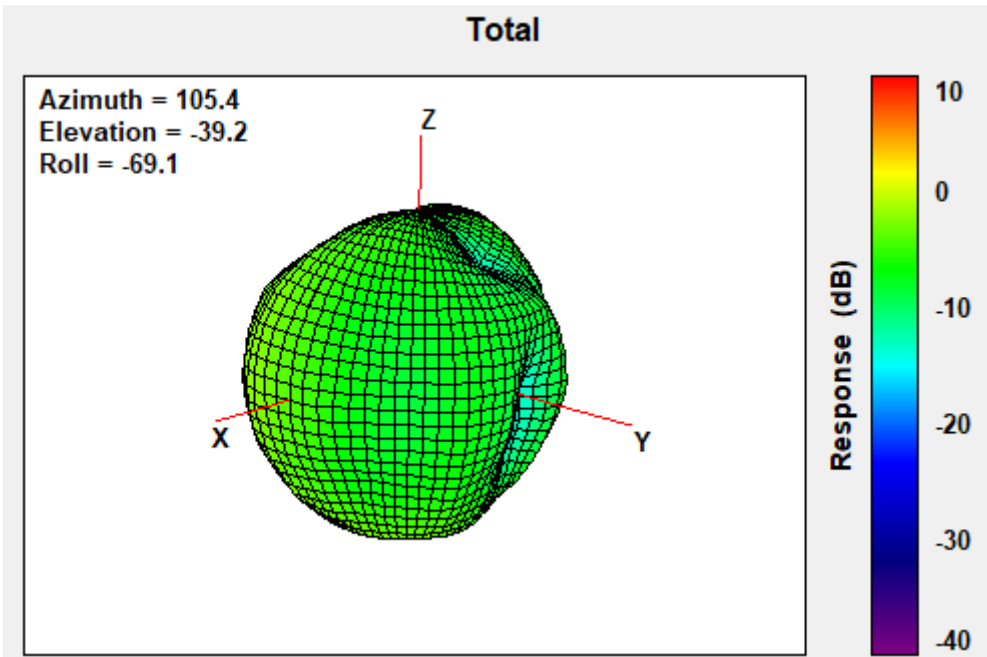

832MHz

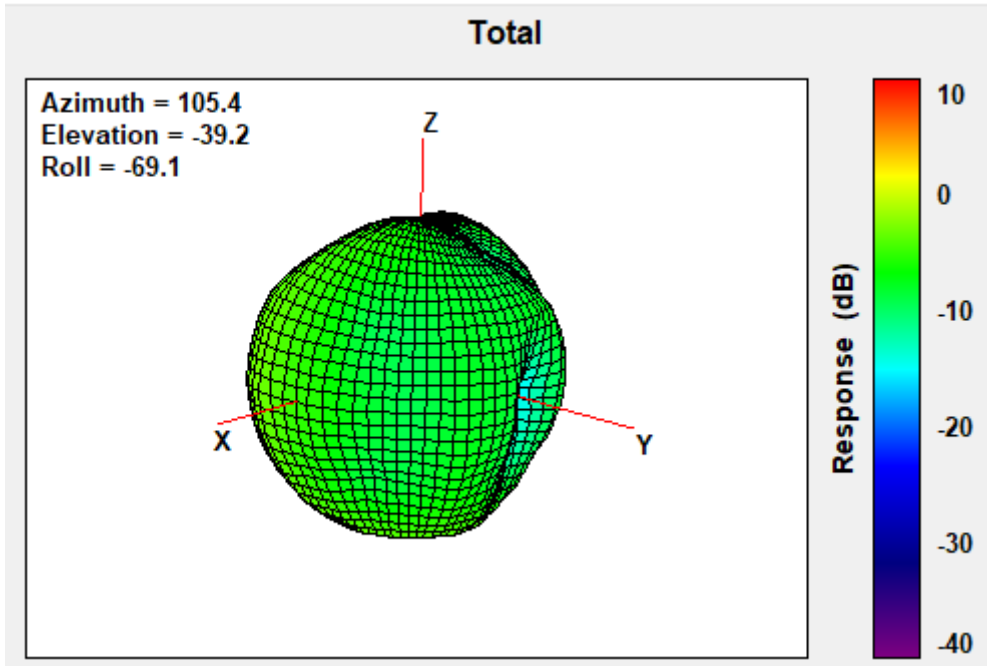

Center Frequency	832MHz
Horizontal (dBi) peak	-4.13
Vertical (dBi) peak	-4.47

836.5MHz

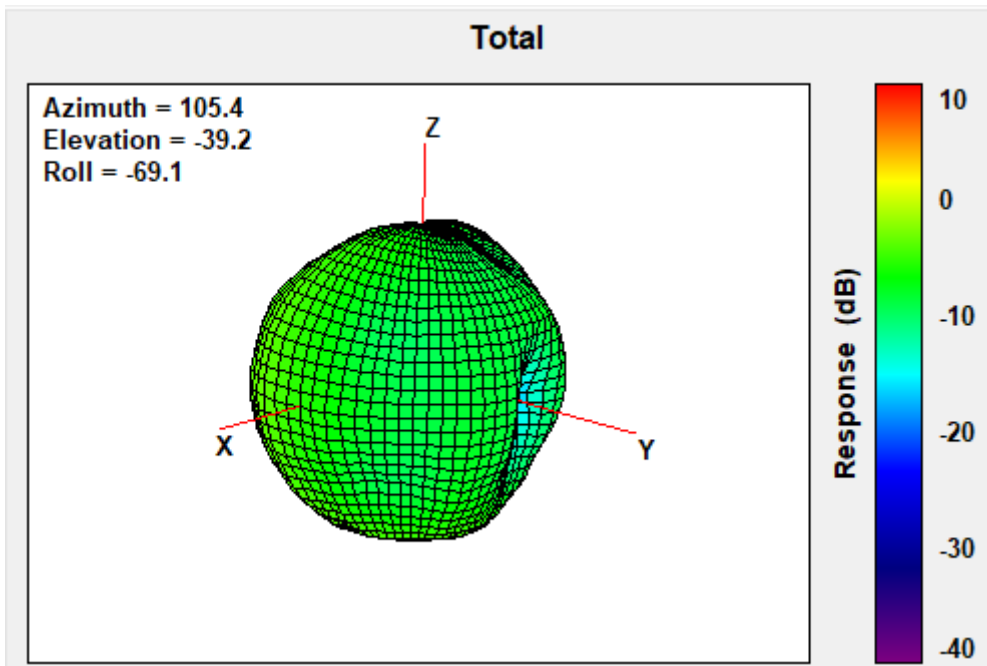

Center Frequency	836.5MHz
Horizontal (dBi) peak	-4.21
Vertical (dBi) peak	-4.40

849MHz

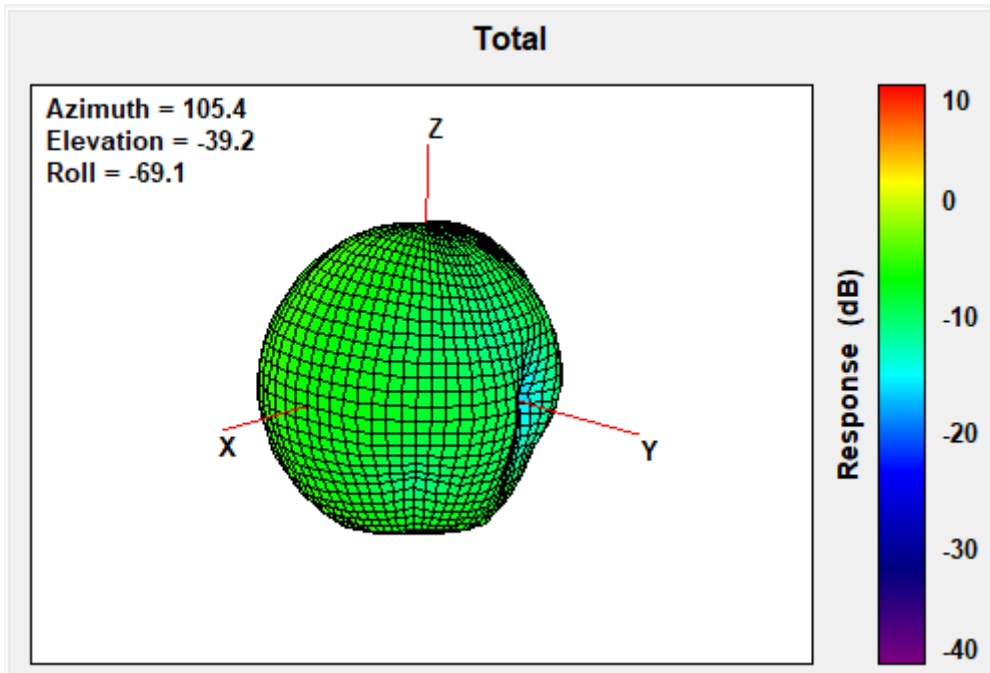

862MHz

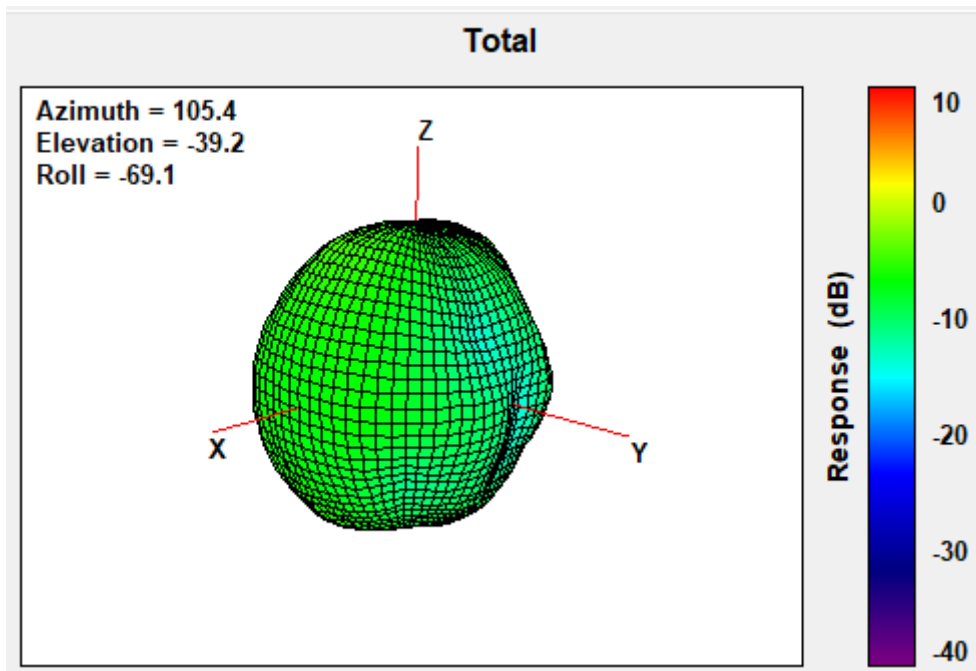

880MHz

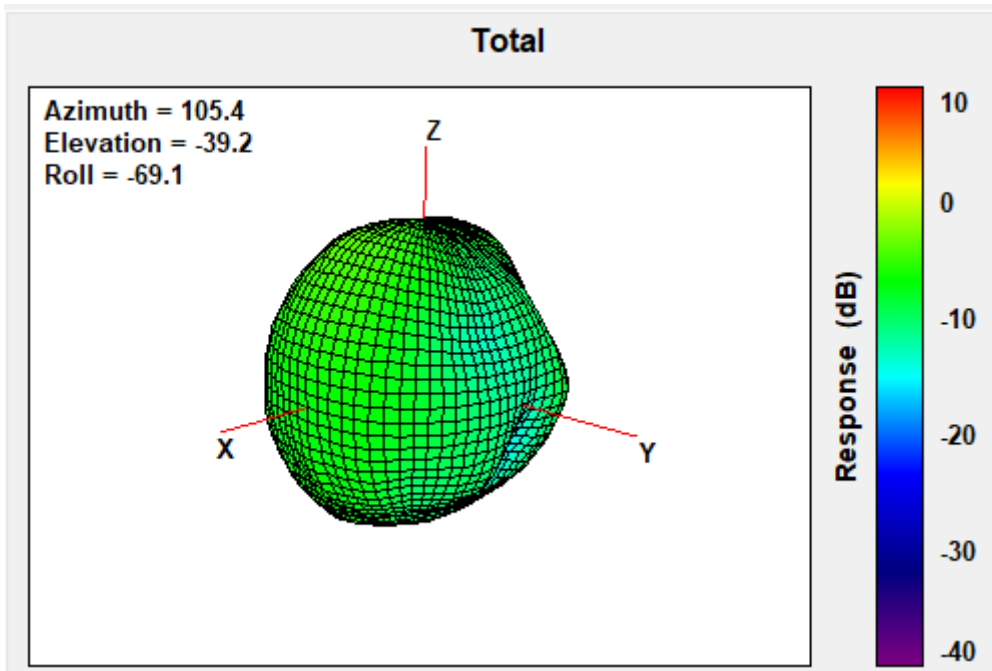

Center Frequency	880MHz
Horizontal (dBi) peak	-4.80
Vertical (dBi) peak	-4.02

897.5MHz

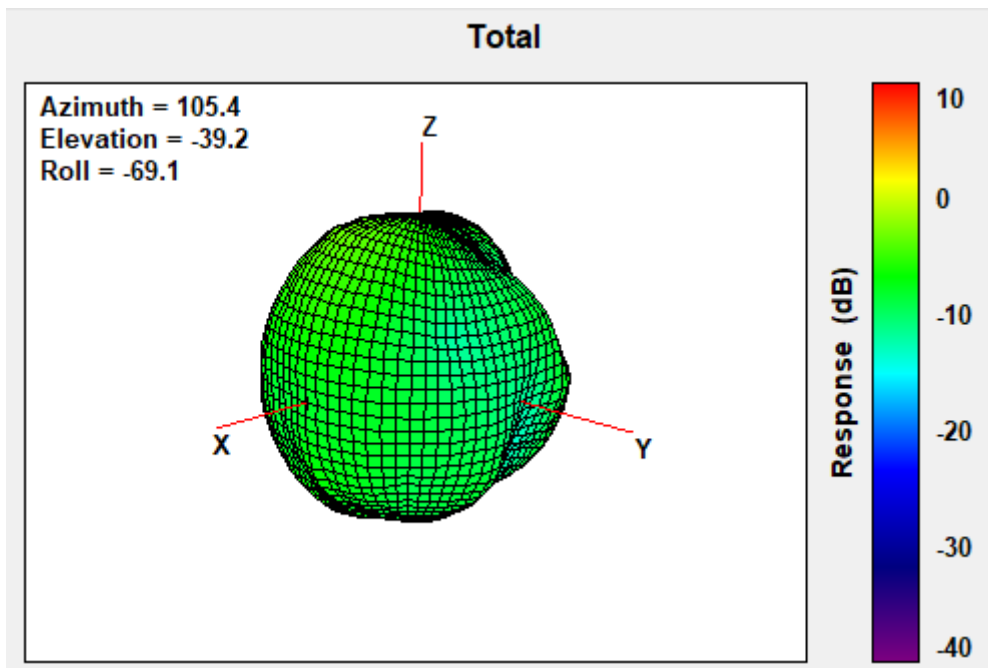

Center Frequency	897.5MHz
Horizontal (dBi) peak	-5.43
Vertical (dBi) peak	-4.37

915MHz

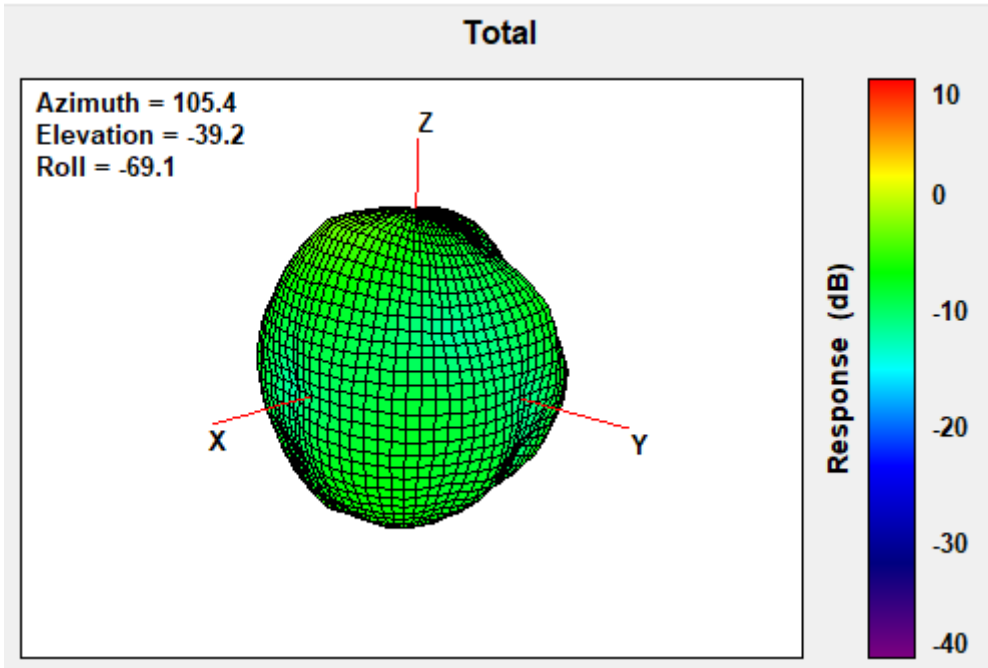

Center Frequency	915MHz
Horizontal (dBi) peak	-4.20
Vertical (dBi) peak	-4.85

925MHz

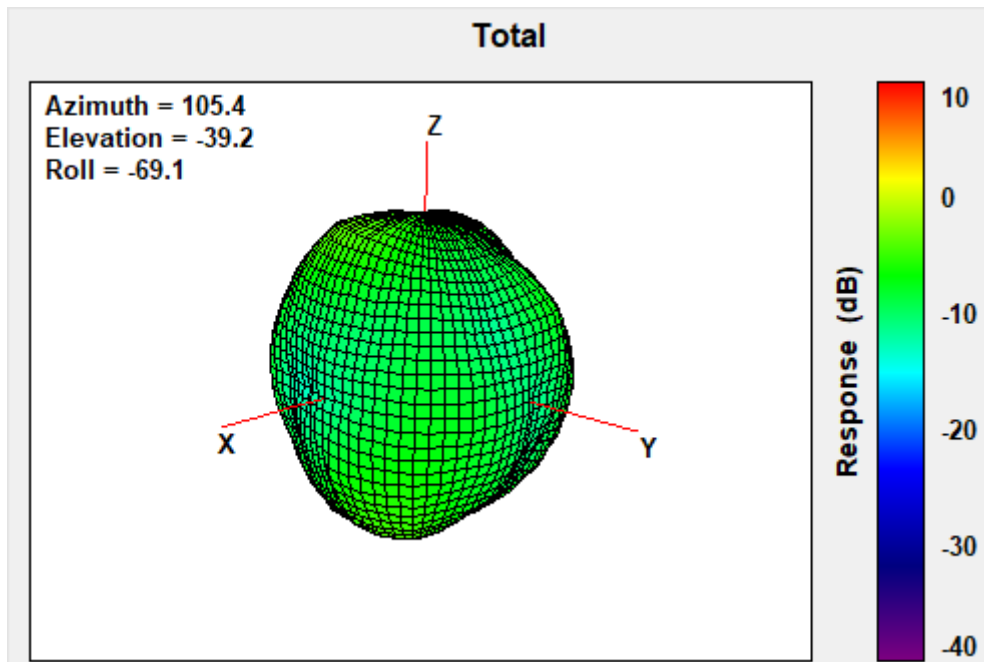

Center Frequency	925MHz
Horizontal (dBi) peak	-4.69
Vertical (dBi) peak	-4.22

960MHz

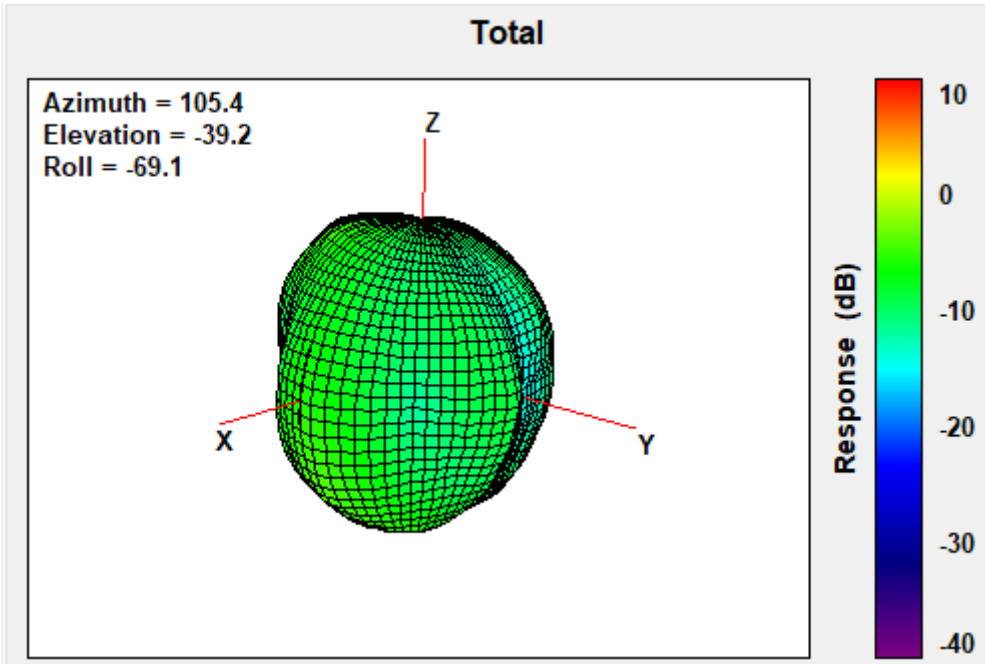

Center Frequency	960MHz
Horizontal (dBi) peak	-5.18
Vertical (dBi) peak	-5.06

1427.9MHz

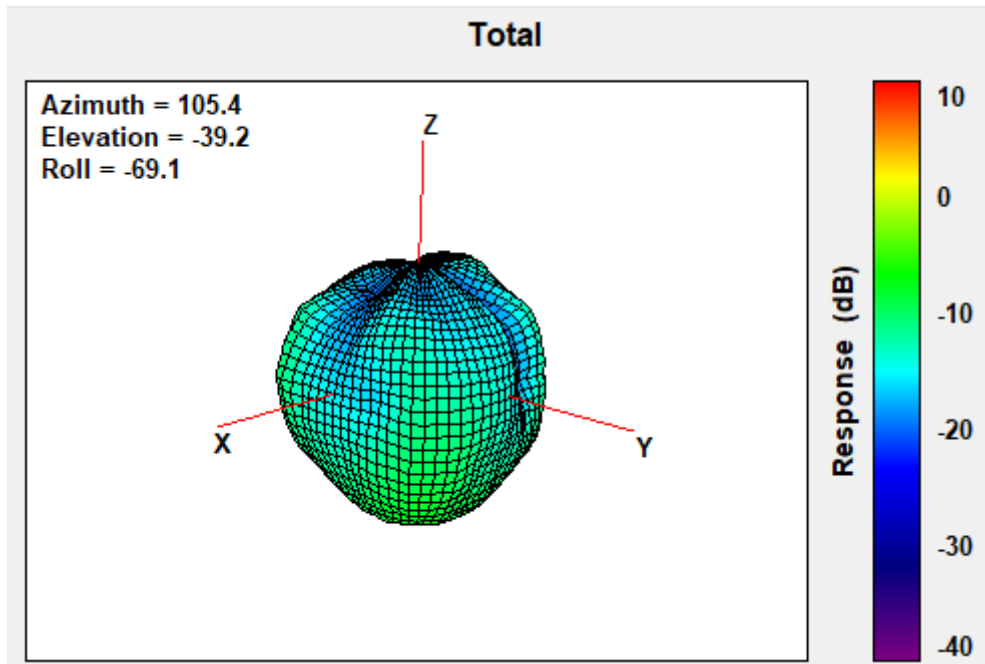

Center Frequency	1427.9MHz
Horizontal (dBi) peak	-6.41
Vertical (dBi) peak	-5.52

1447.9MHz

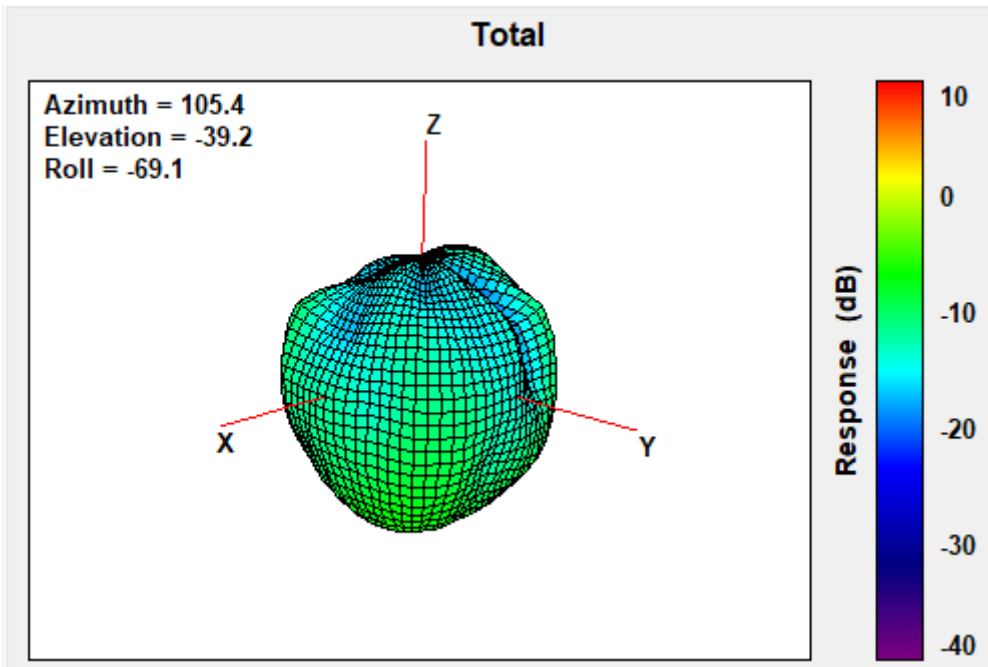

Center Frequency	1447.9MHz
Horizontal (dBi) peak	-7.35
Vertical (dBi) peak	-6.06

1455.4MHz

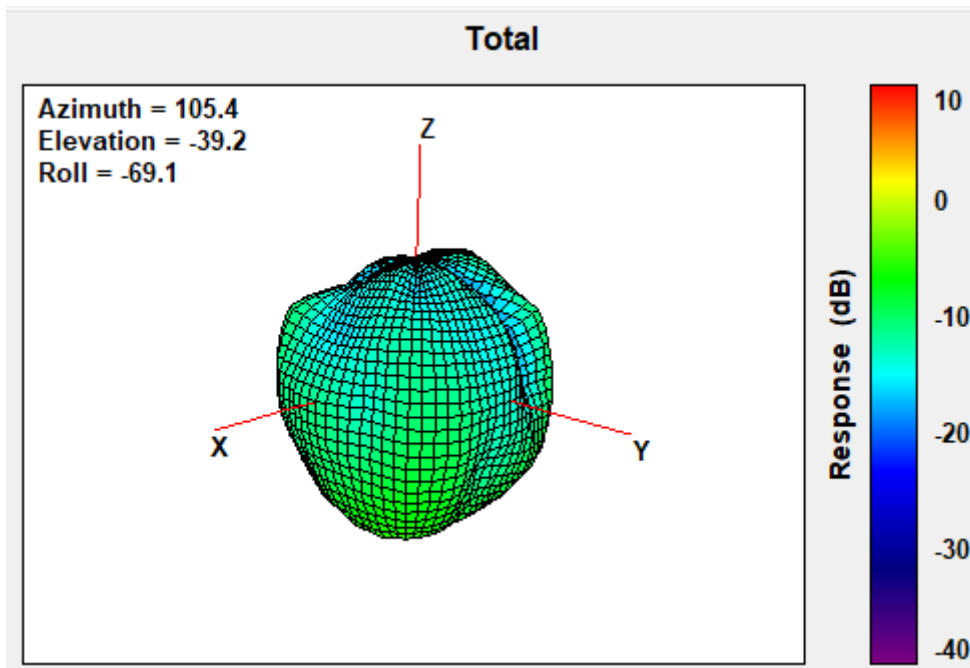

Center Frequency	1455.4MHz
Horizontal (dBi) peak	-7.91
Vertical (dBi) peak	-5.83

1462.9MHz

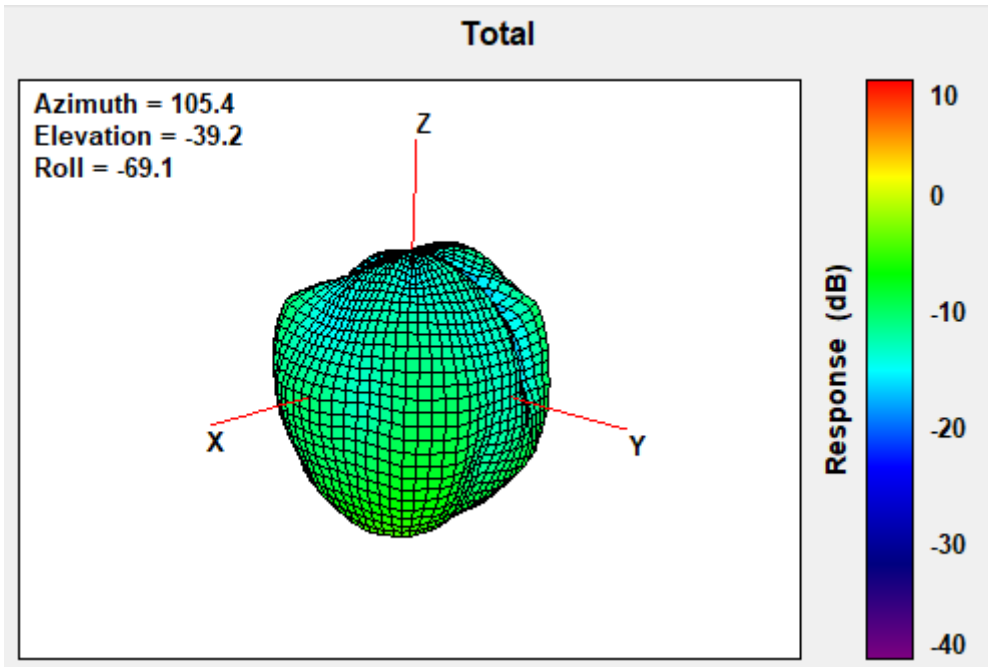

Center Frequency	1462.9MHz
Horizontal (dBi) peak	-7.99
Vertical (dBi) peak	-5.20

1496MHz

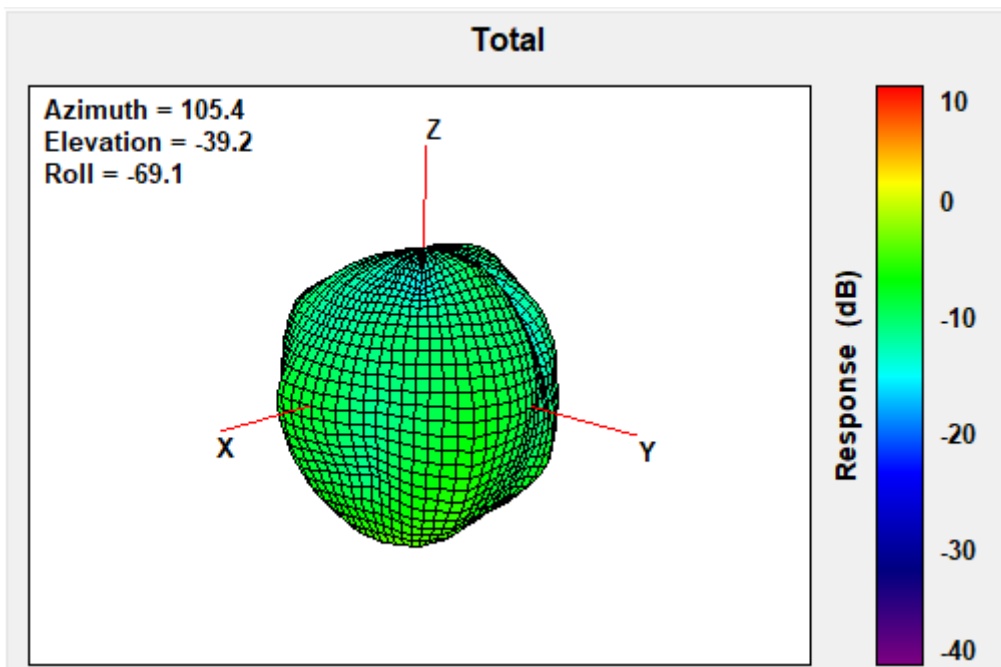

Center Frequency	1496MHz
Horizontal (dBi) peak	-6.65
Vertical (dBi) peak	-4.32

1510.9MHz

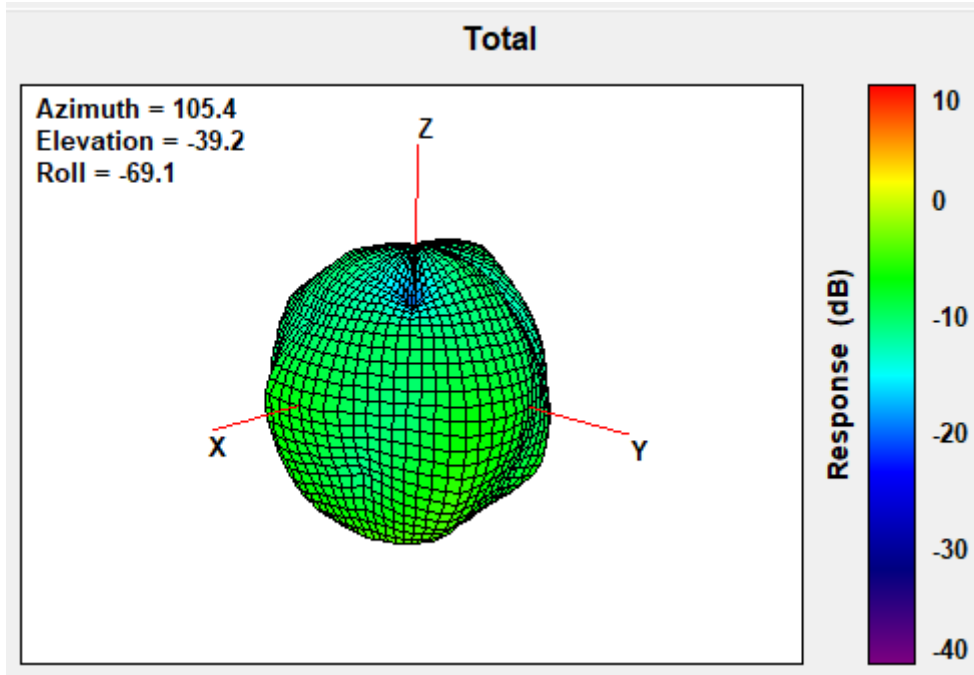

Center Frequency	1510.9MHz
Horizontal (dBi) peak	-6.31
Vertical (dBi) peak	-4.23

1557MHz

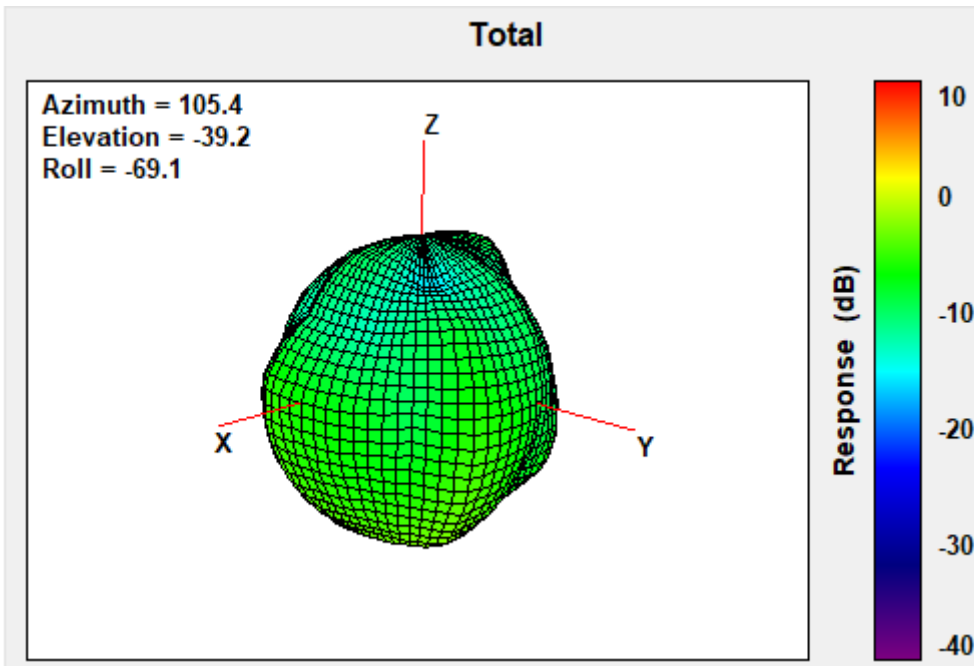

Center Frequency	1557MHz
Horizontal (dBi) peak	-4.33
Vertical (dBi) peak	-3.83

1575MHz

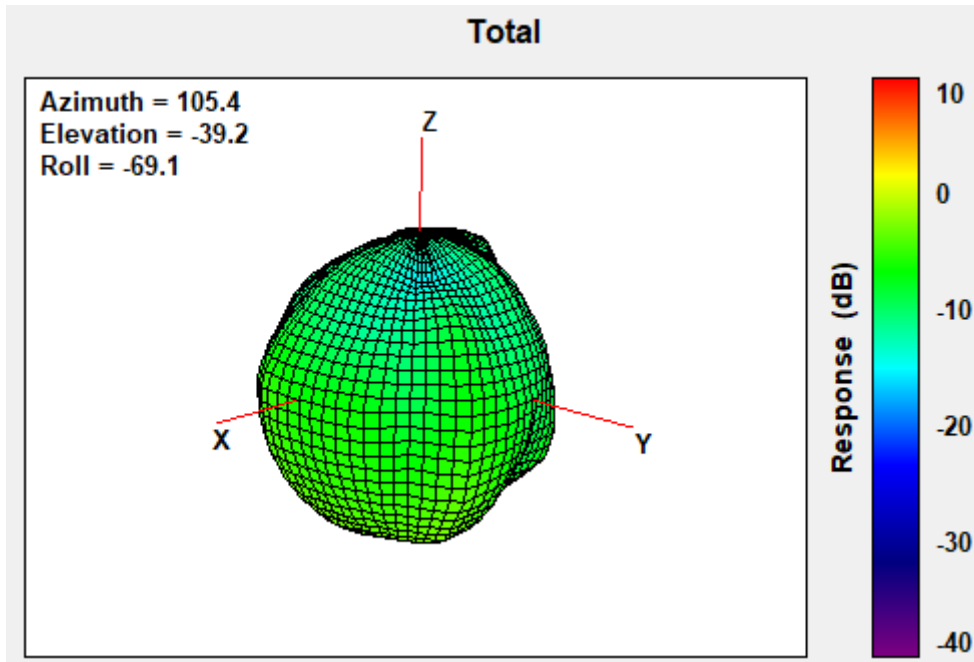

Center Frequency	1575MHz
Horizontal (dBi) peak	-4.02
Vertical (dBi) peak	-4.11

1610MHz

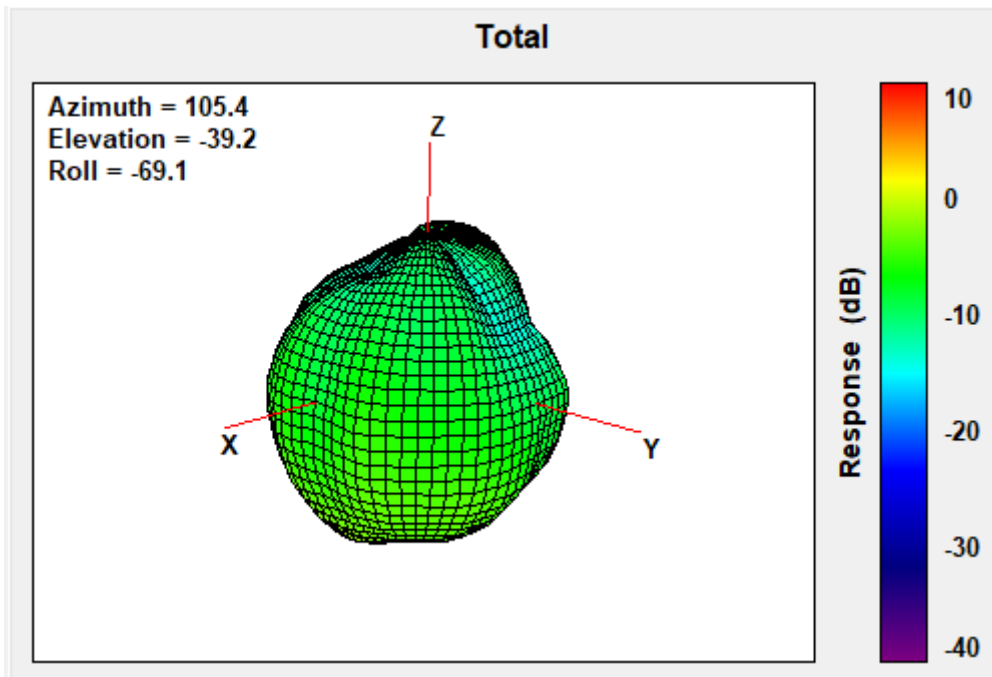

Center Frequency	1610MHz
Horizontal (dBi) peak	-4.64
Vertical (dBi) peak	-4.22

1805 MHz

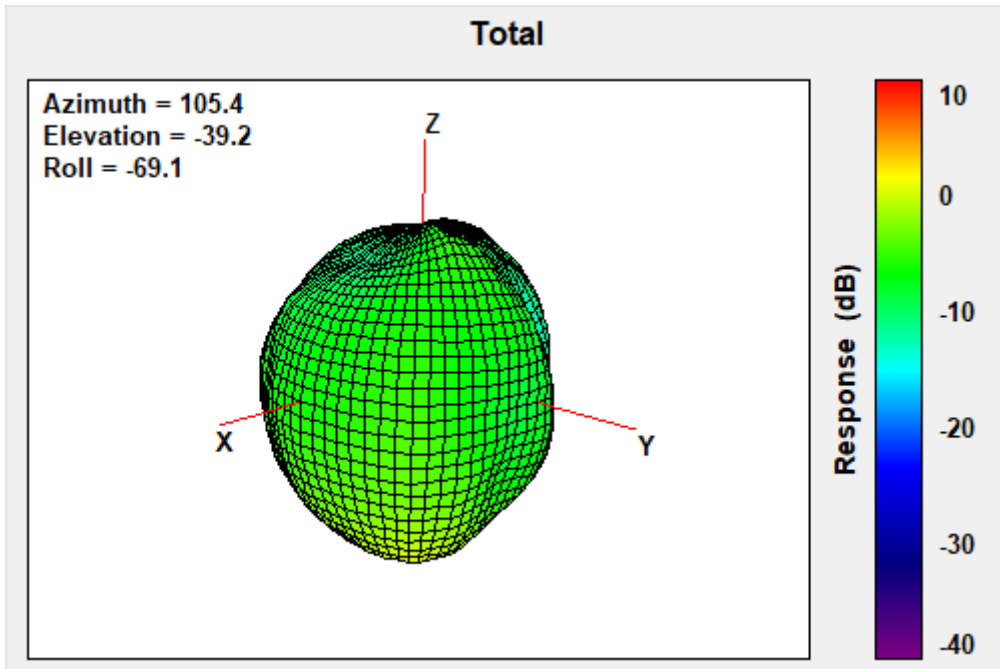

Center Frequency	1805 MHz
Horizontal (dBi) peak	-2.08
Vertical (dBi) peak	0.51

1850 MHz

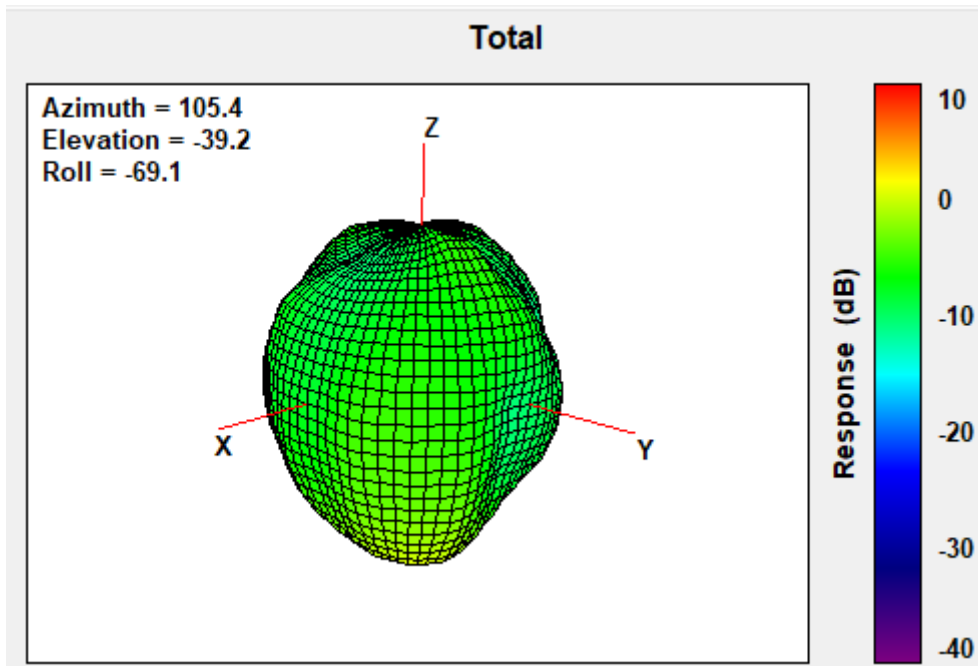

Center Frequency	1850 MHz
Horizontal (dBi) peak	-1.33
Vertical (dBi) peak	-0.40

1880 MHz

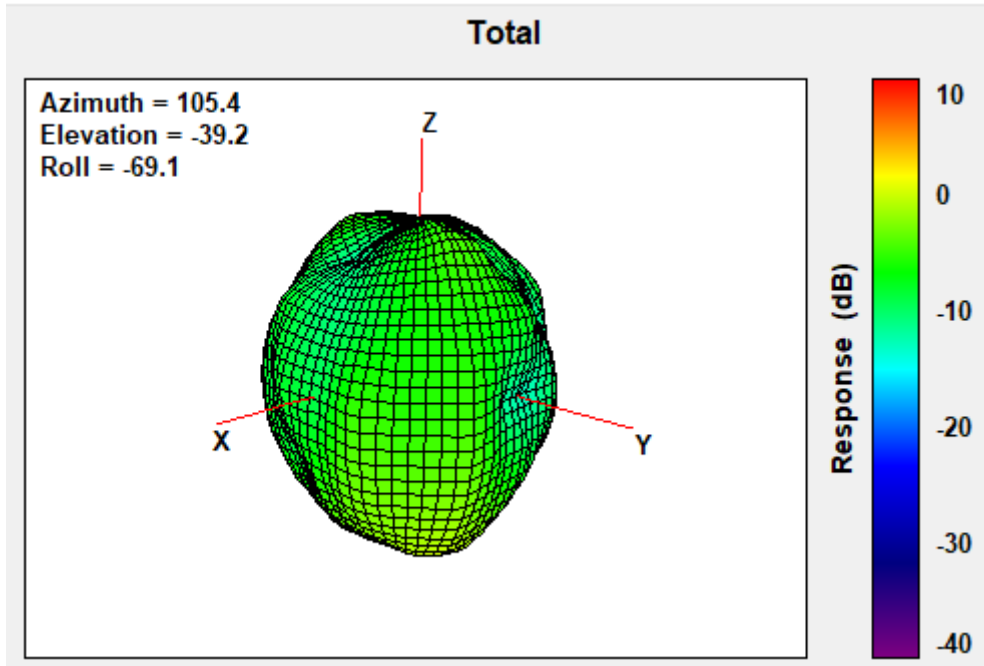

Center Frequency	1880 MHz
Horizontal (dBi) peak	-0.77
Vertical (dBi) peak	-2.74

1910MHz

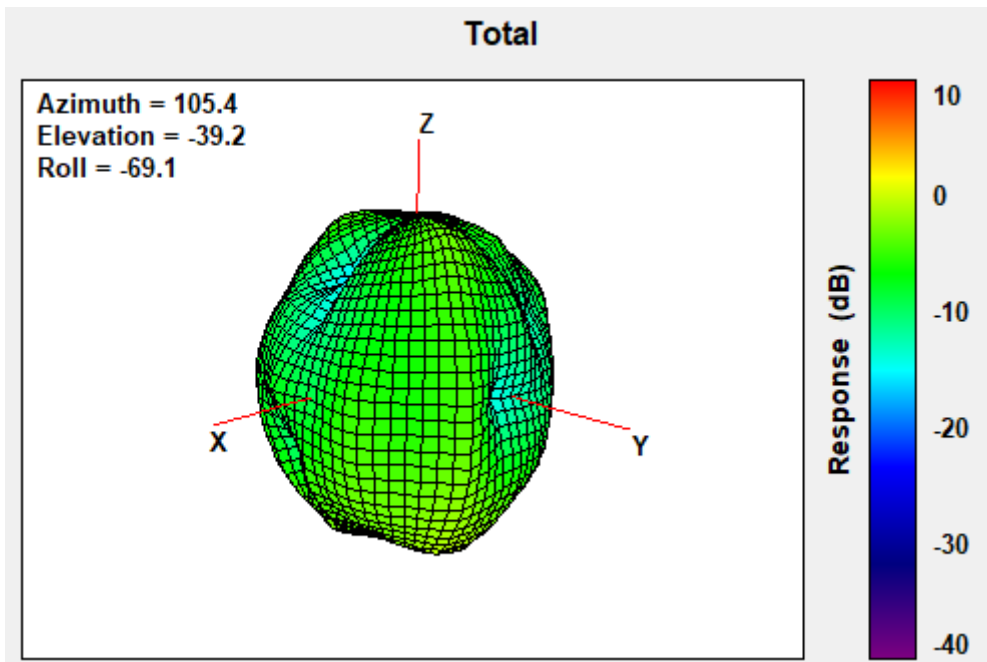

Center Frequency	1910MHz
Horizontal (dBi) peak	-0.74
Vertical (dBi) peak	-3.89

1920MHz

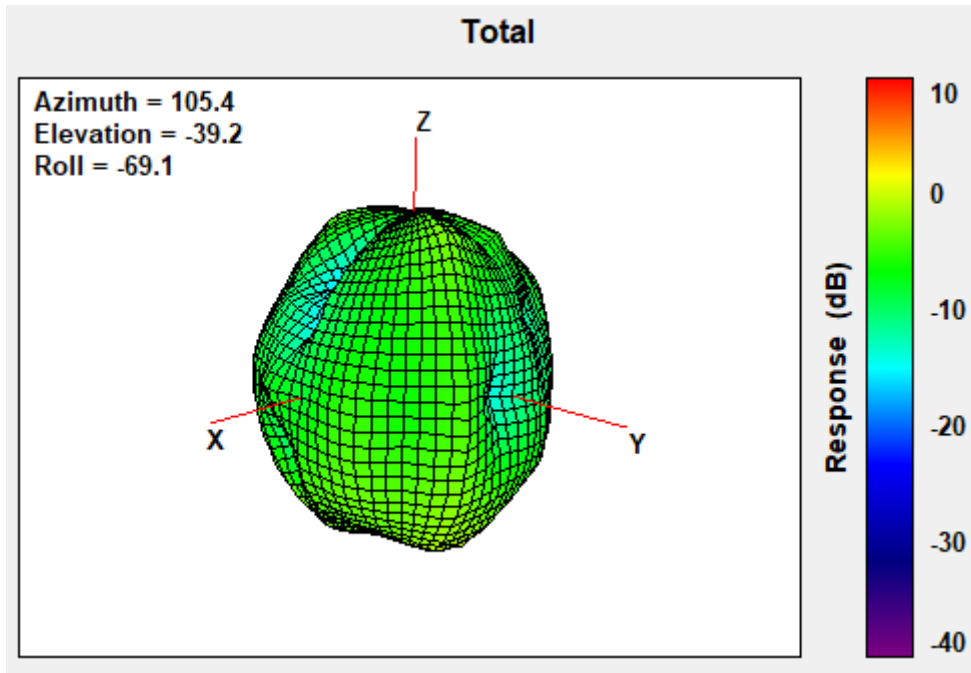

Center Frequency	1920MHz
Horizontal (dBi) peak	-0.78
Vertical (dBi) peak	-3.98

1950MHz

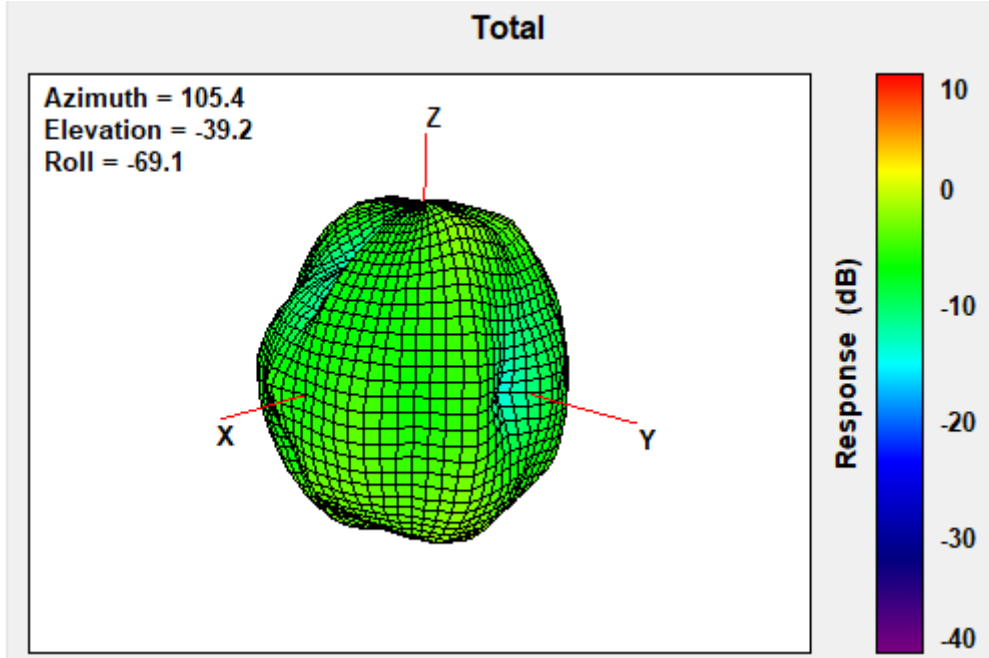

Center Frequency	1950MHz
Horizontal (dBi) peak	-0.99
Vertical (dBi) peak	-2.64

1980MHz

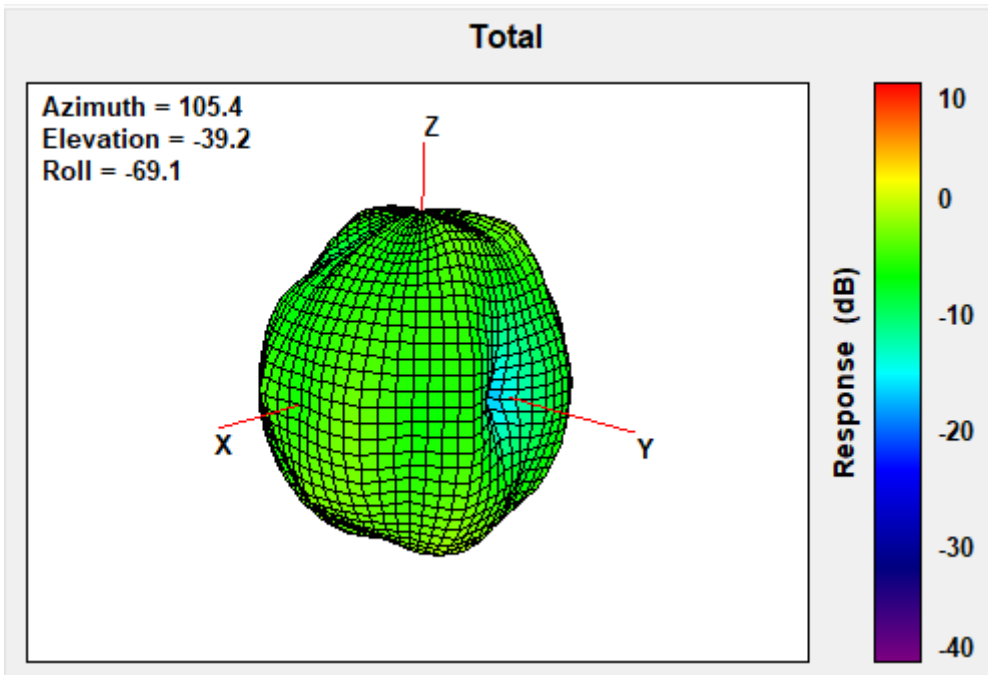

Center Frequency	1980MHz
Horizontal (dBi) peak	-1.72
Vertical (dBi) peak	-0.90

2110MHz

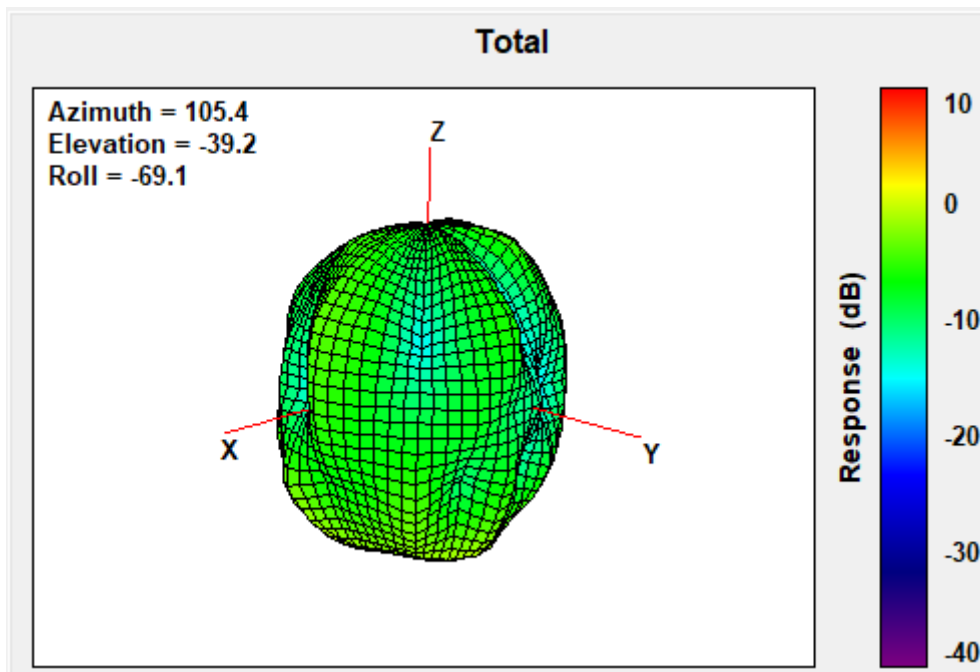

Center Frequency	2110MHz
Horizontal (dBi) peak	0.46
Vertical (dBi) peak	-0.59

2200MHz

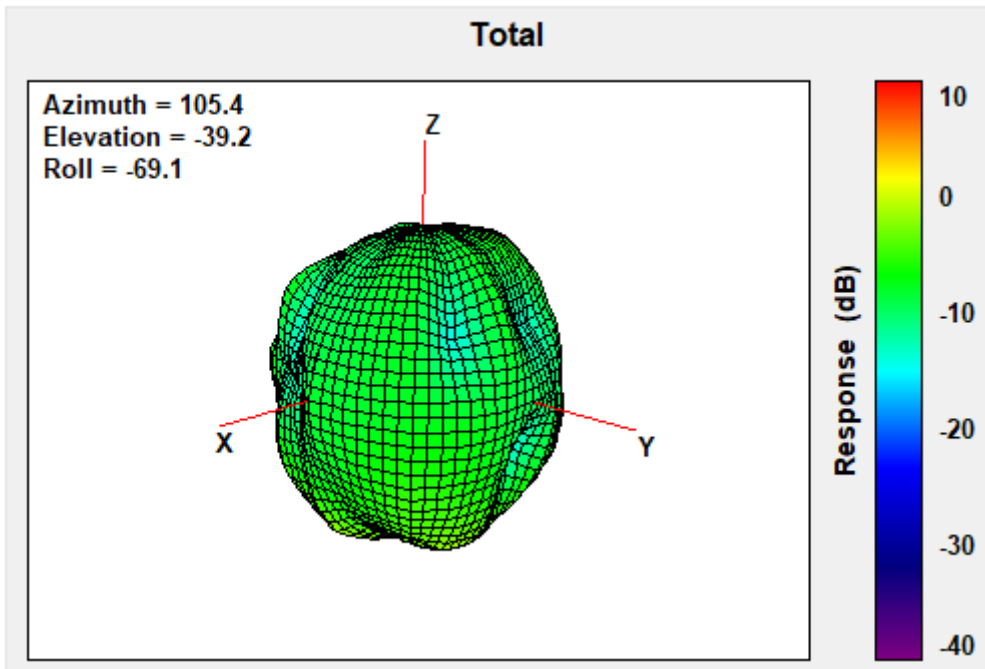

Center Frequency	2200MHz
Horizontal (dBi) peak	0.10
Vertical (dBi) peak	0.20

2300MHz

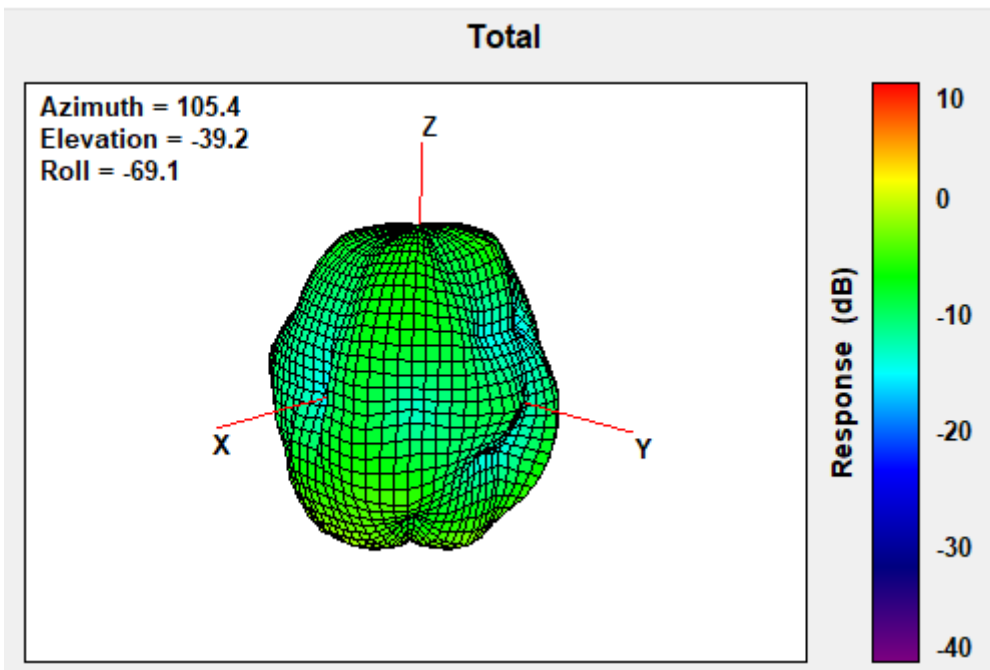

Center Frequency	2300MHz
Horizontal (dBi) peak	0.77
Vertical (dBi) peak	-0.82

2305MHz

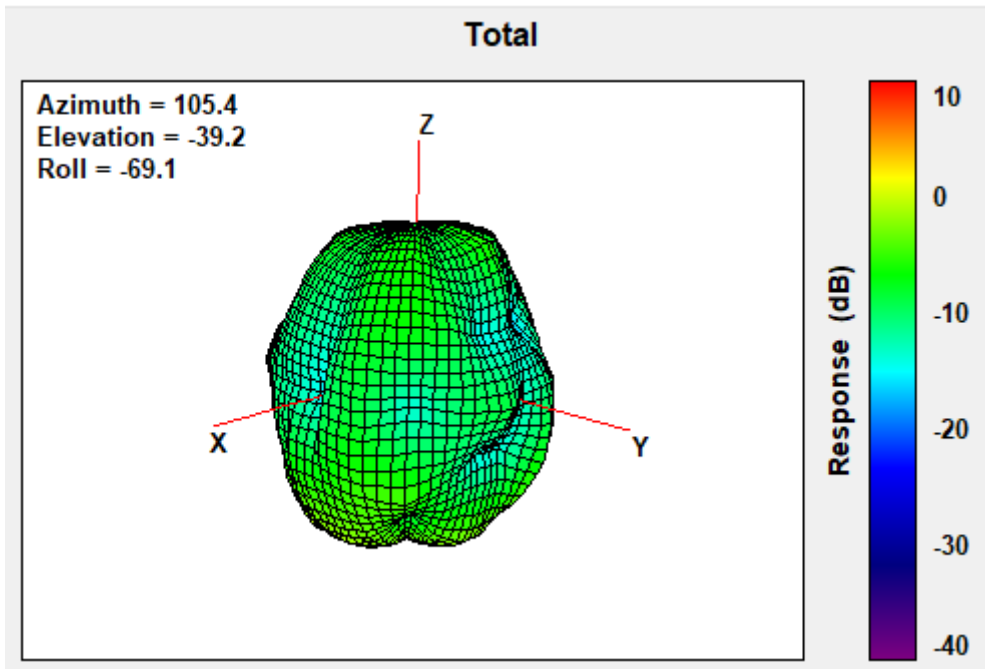

Center Frequency	2305MHz
Horizontal (dBi) peak	0.69
Vertical (dBi) peak	-0.95

2315MHz

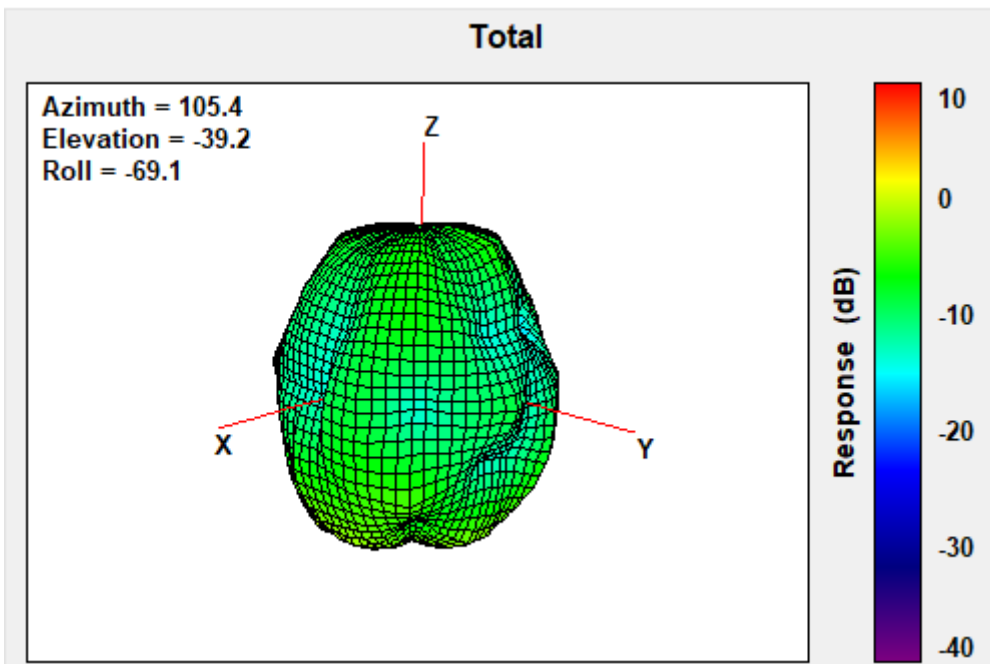

Center Frequency	2315MHz
Horizontal (dBi) peak	0.50
Vertical (dBi) peak	-1.32

2350MHz

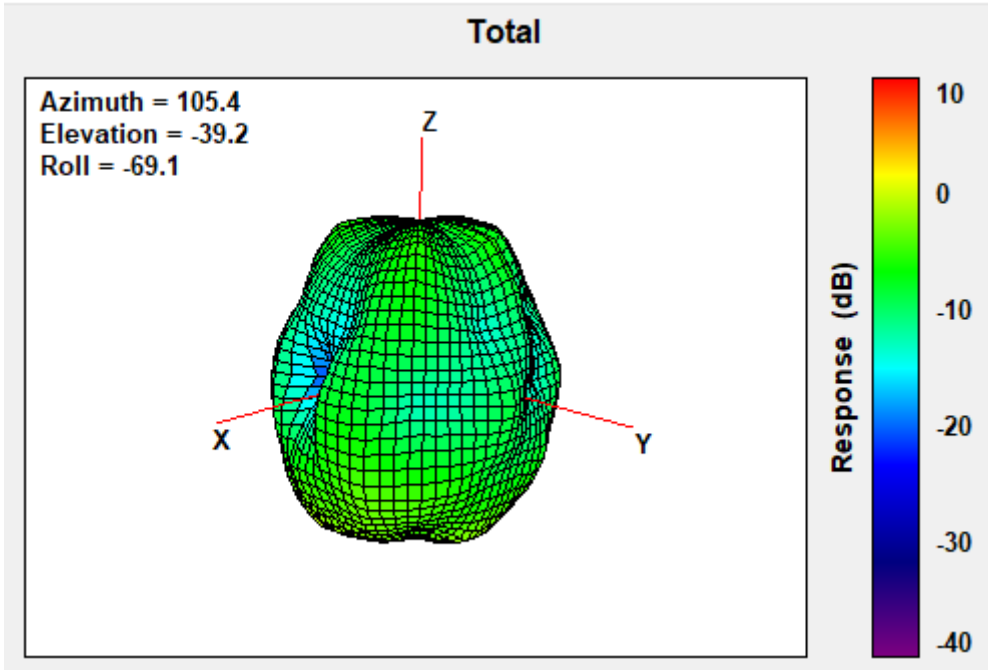

Center Frequency	2350MHz
Horizontal (dBi) peak	0.75
Vertical (dBi) peak	-1.71

2400MHz

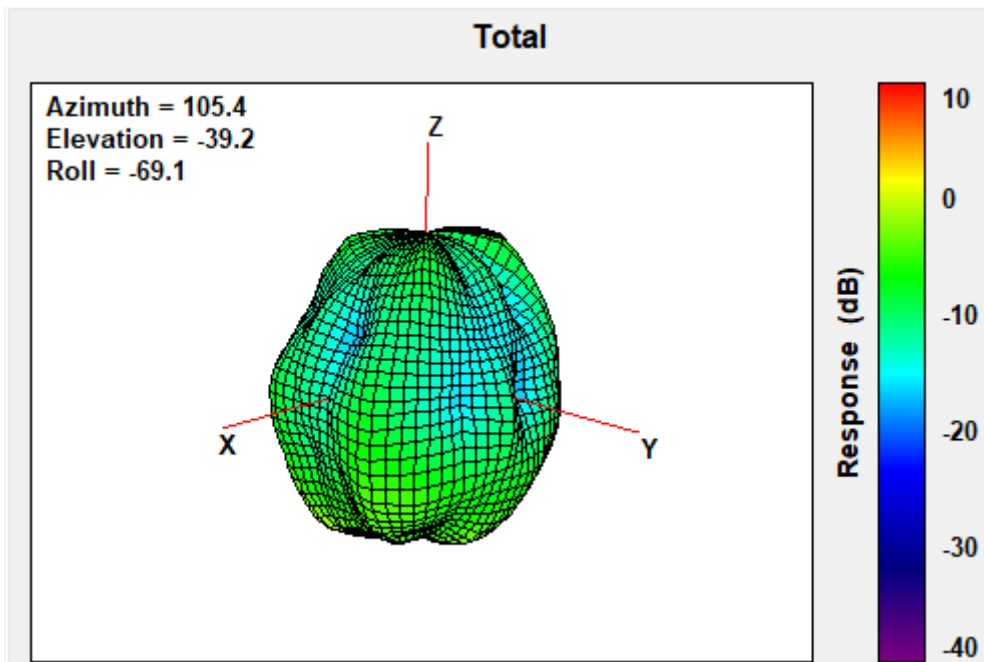

Center Frequency	2400MHz
Horizontal (dBi) peak	0.53
Vertical (dBi) peak	-2.19

2500MHz

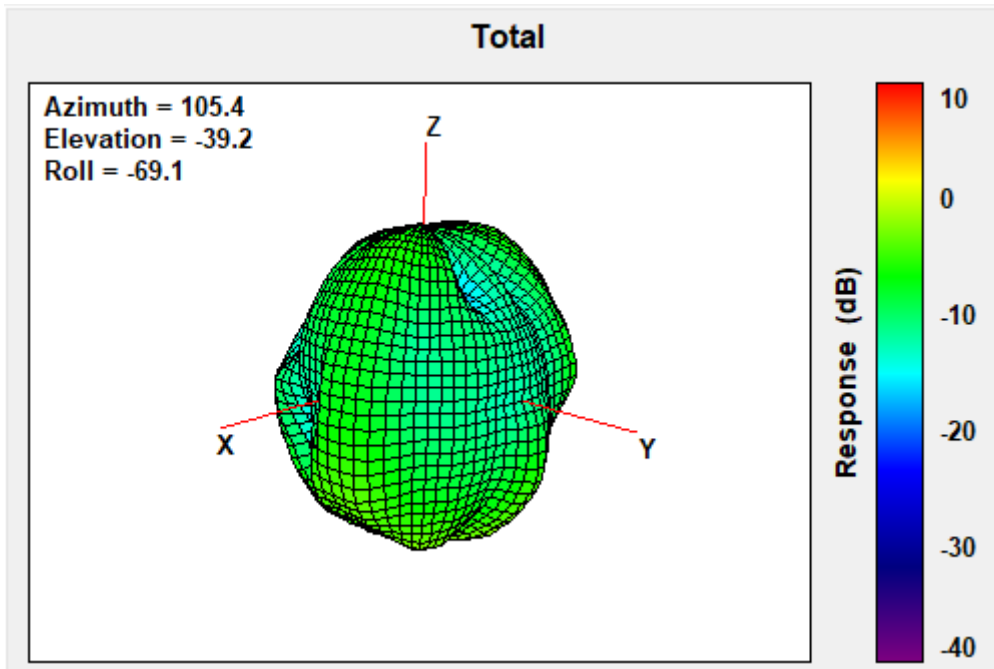

Center Frequency	2500MHz
Horizontal (dBi) peak	1.76
Vertical (dBi) peak	-2.10

2570MHz

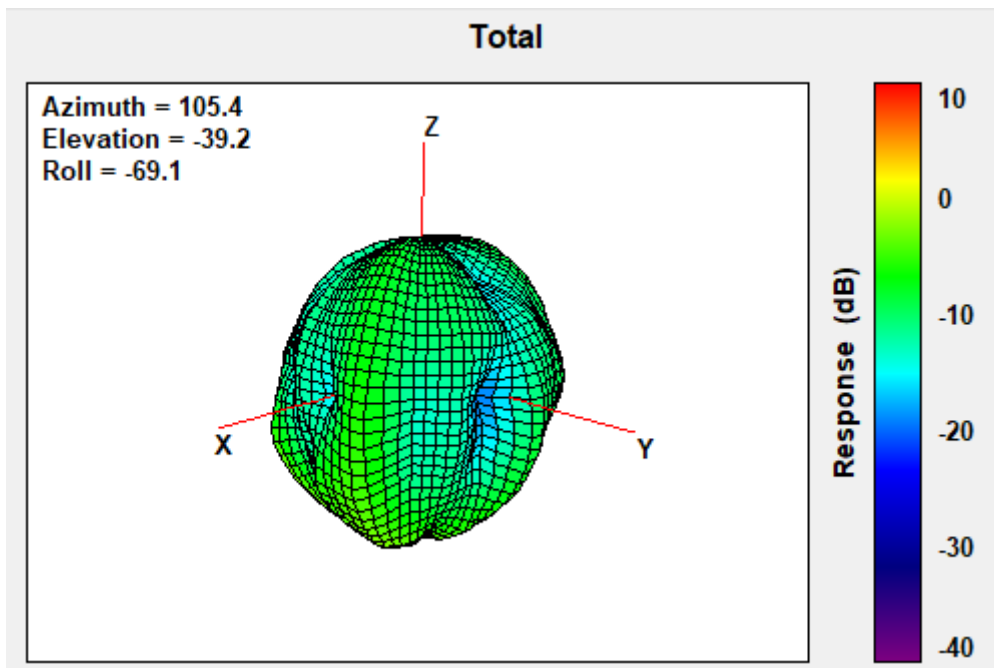

Center Frequency	2570MHz
Horizontal (dBi) peak	2.15
Vertical (dBi) peak	-1.62

2595MHz

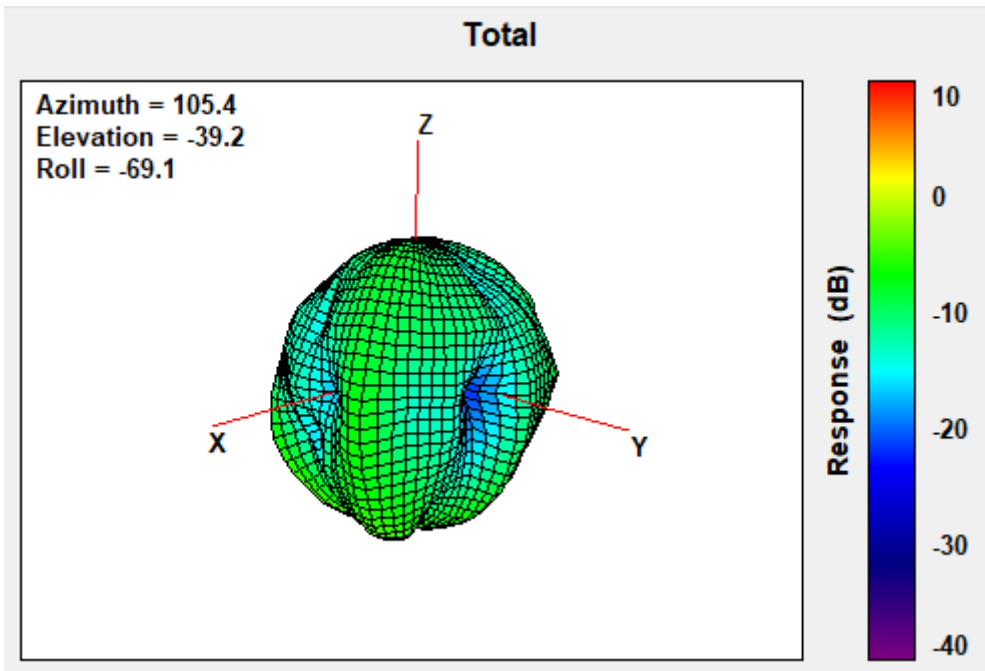

Center Frequency	2595MHz
Horizontal (dBi) peak	1.08
Vertical (dBi) peak	-3.00

2620MHz

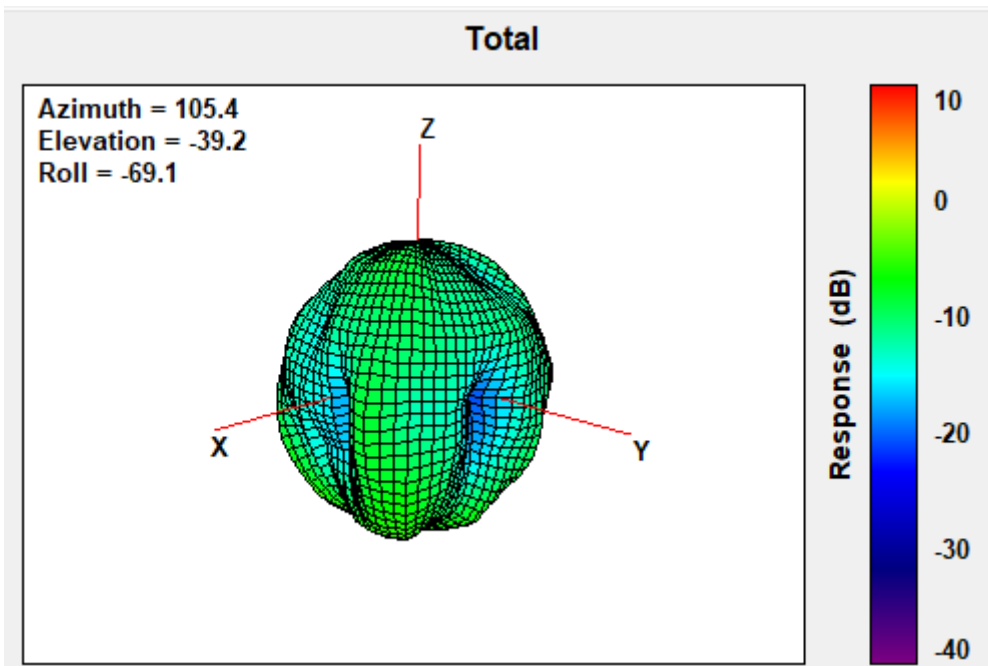

Center Frequency	2620MHz
Horizontal (dBi) peak	0.13
Vertical (dBi) peak	-3.99

2690MHz

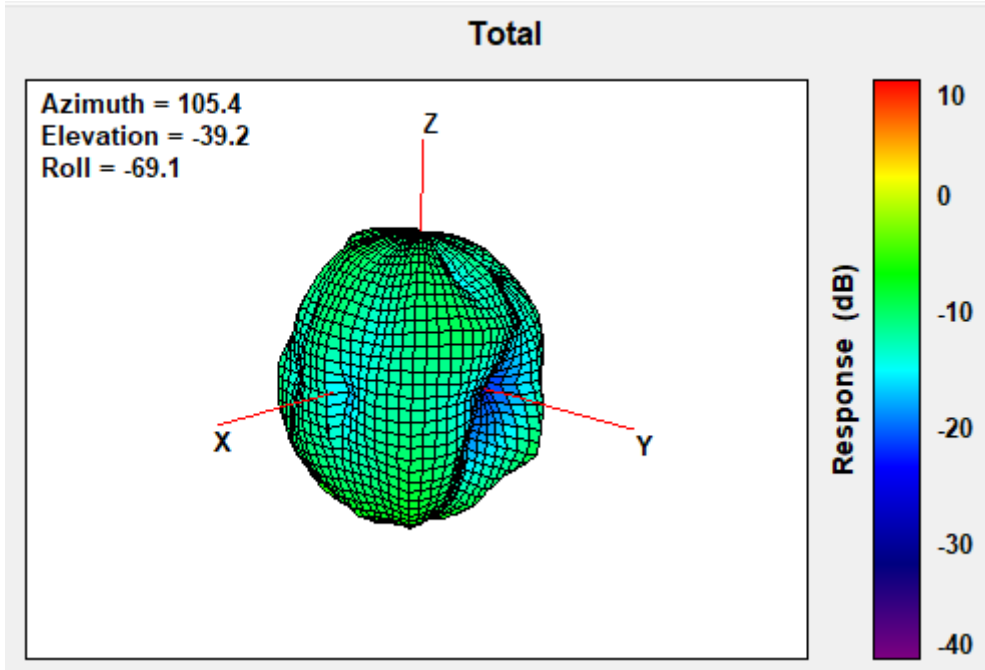

Center Frequency	2690MHz
Horizontal (dBi) peak	-1.33
Vertical (dBi) peak	-3.19

3400MHz

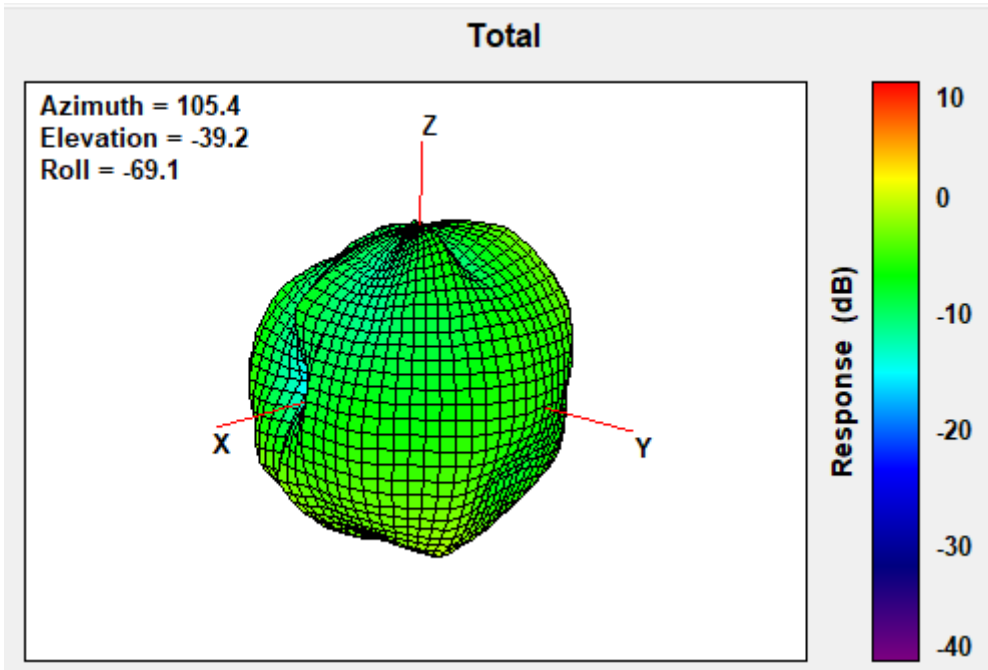

Center Frequency	3400MHz
Horizontal (dBi) peak	-0.30
Vertical (dBi) peak	0.56

3500MHz

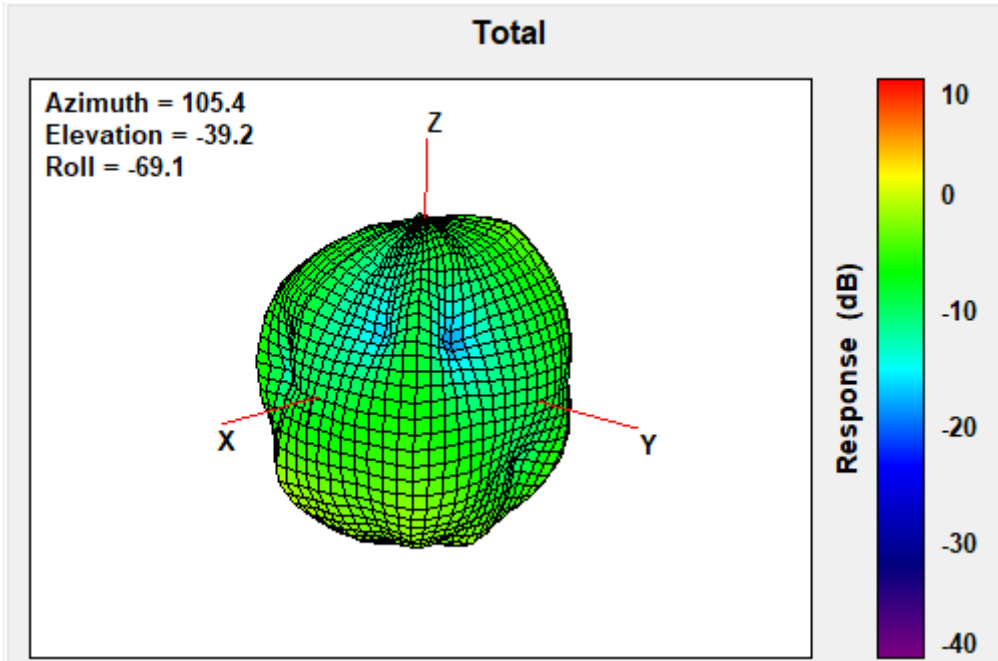

Center Frequency	3500MHz
Horizontal (dBi) peak	0.45
Vertical (dBi) peak	0.49

3600MHz

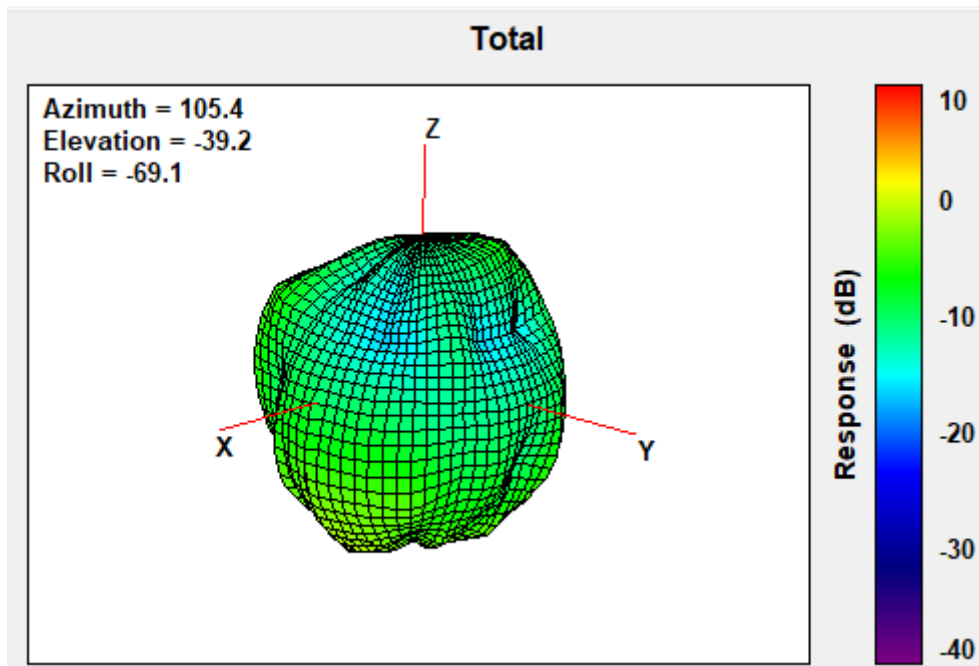

Center Frequency	3600MHz
Horizontal (dBi) peak	-0.47
Vertical (dBi) peak	-0.15

3700MHz

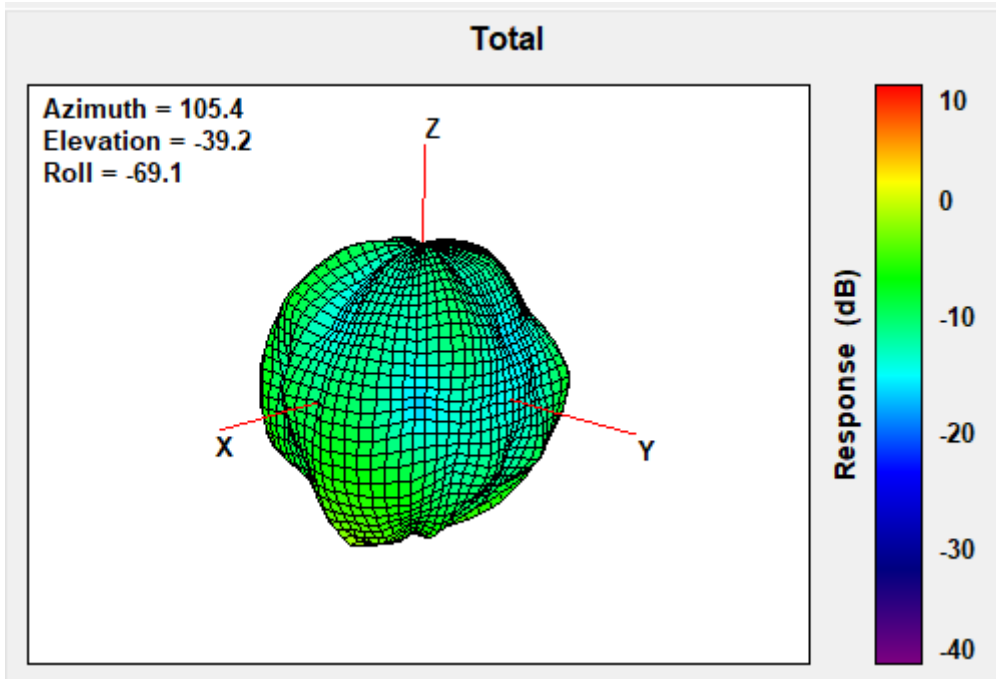

Center Frequency	3700MHz
Horizontal (dBi) peak	-2.04
Vertical (dBi) peak	-1.01

3800MHz

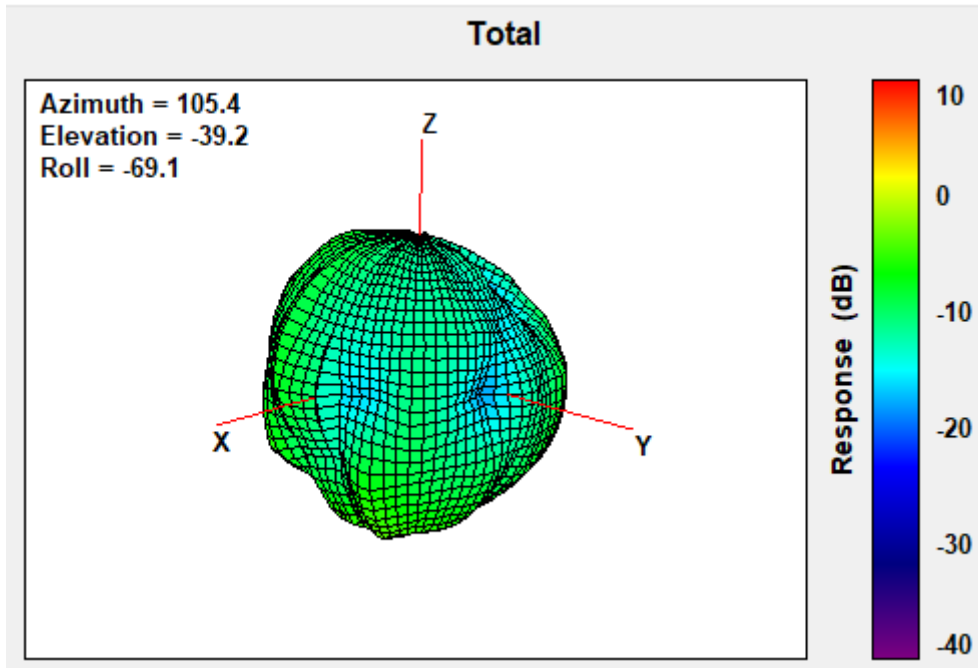

Center Frequency	3800MHz
Horizontal (dBi) peak	-1.83
Vertical (dBi) peak	-4.35

4200MHz

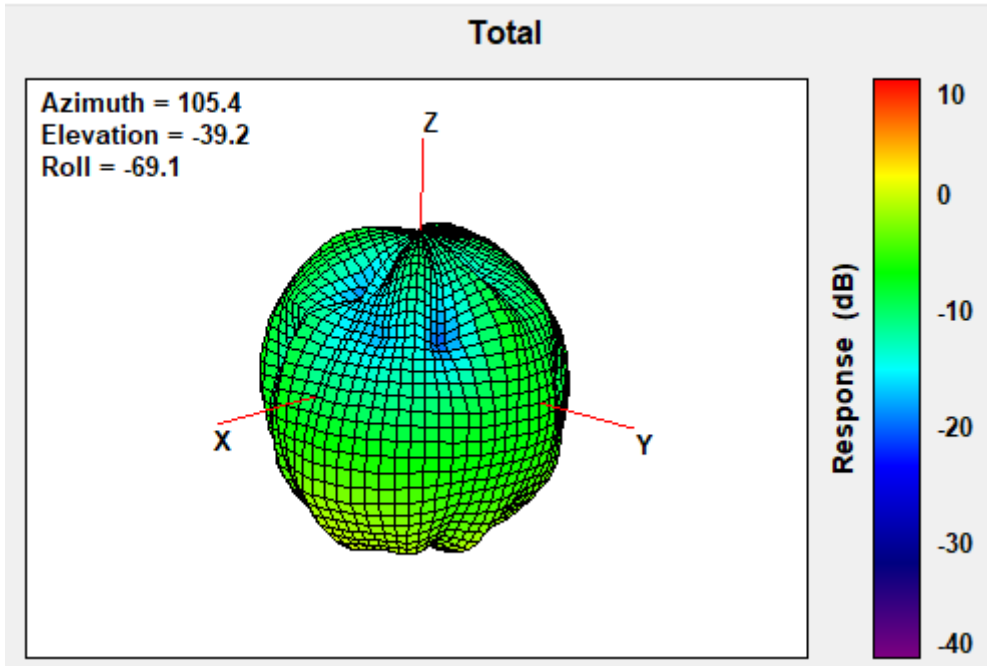

Center Frequency	4200MHz
Horizontal (dBi) peak	1.92
Vertical (dBi) peak	-0.76

4400MHz

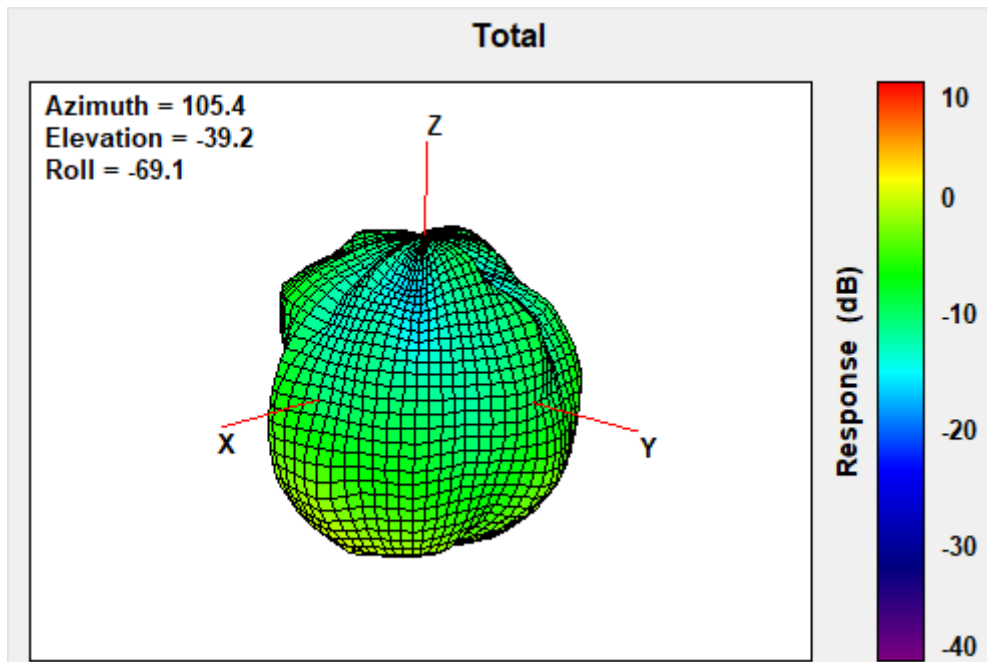

Center Frequency	4400MHz
Horizontal (dBi) peak	2.18
Vertical (dBi) peak	1.52

4700MHz

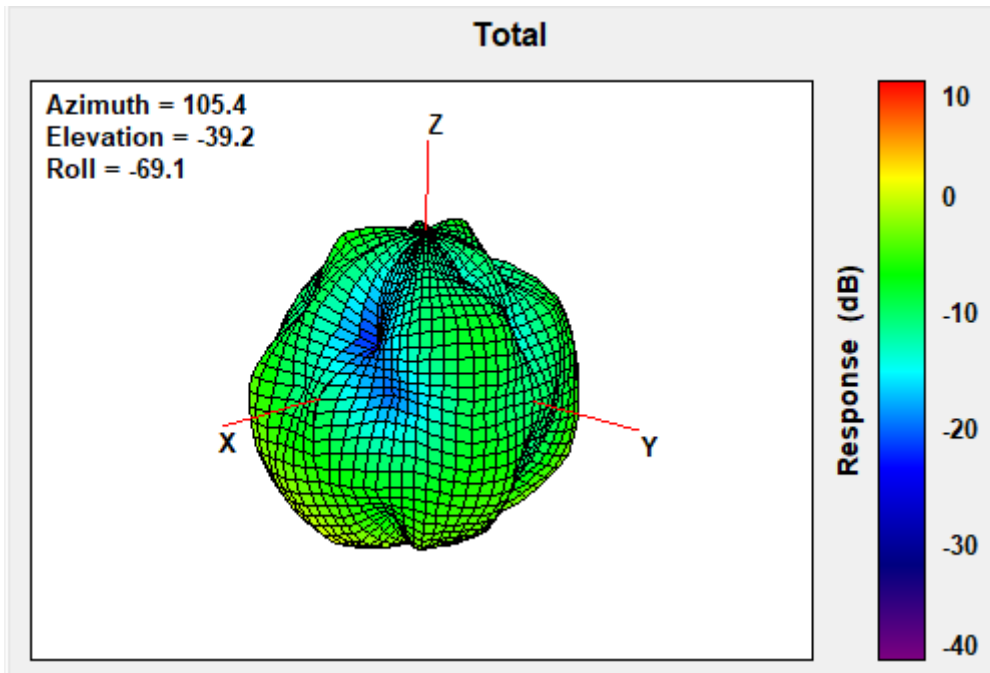

Center Frequency	4700MHz
Horizontal (dBi) peak	2.23
Vertical (dBi) peak	1.32

5150MHz

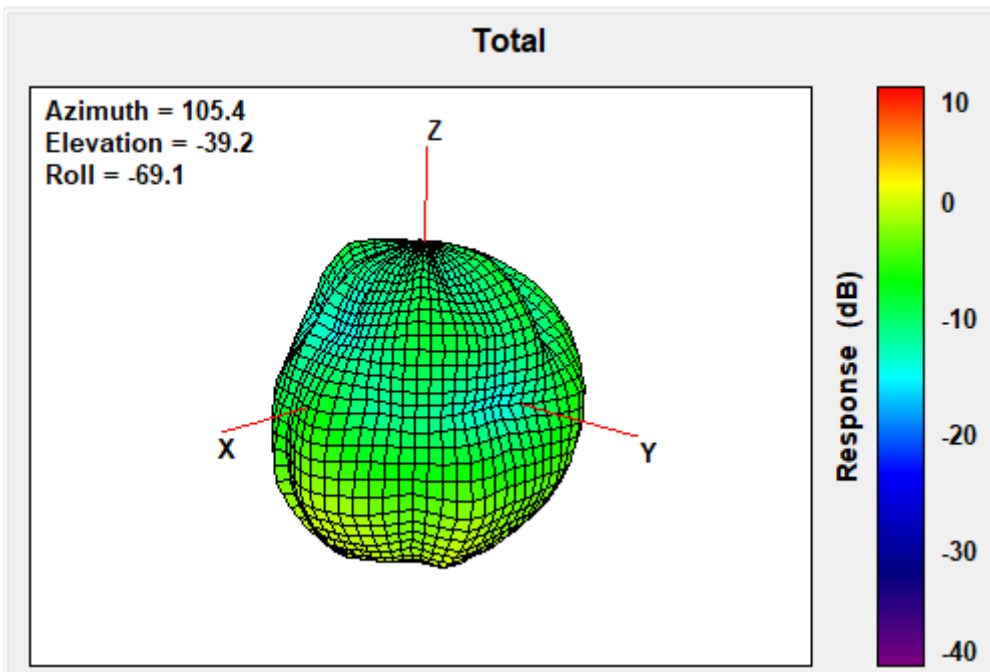

Center Frequency	5150MHz
Horizontal (dBi) peak	1.09
Vertical (dBi) peak	1.89

5537.5MHz

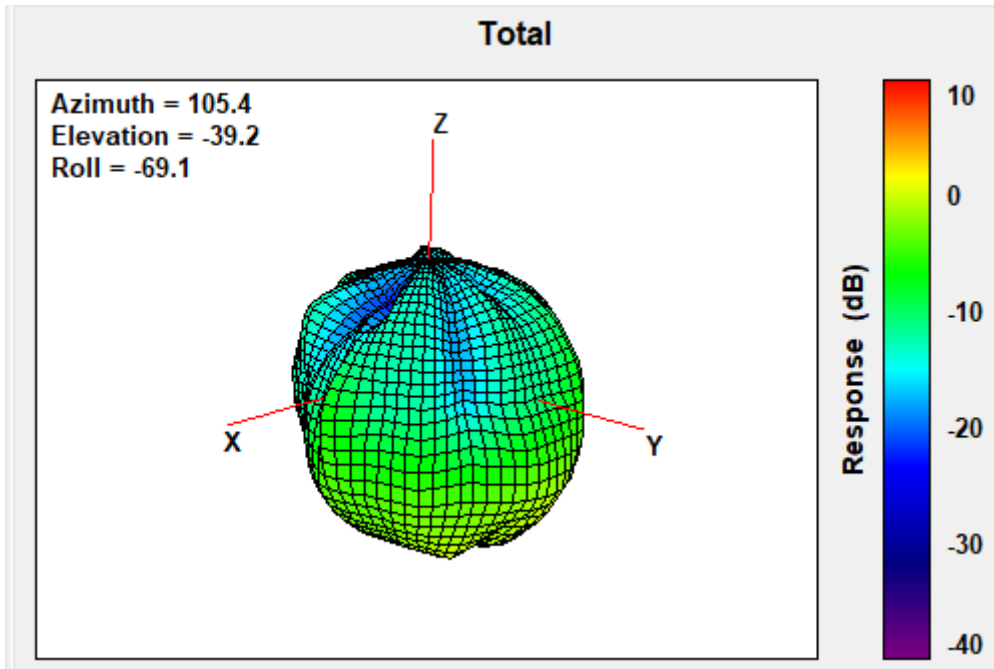

Center Frequency	5537.5MHz
Horizontal (dBi) peak	-1.91
Vertical (dBi) peak	1.13

5925MHz

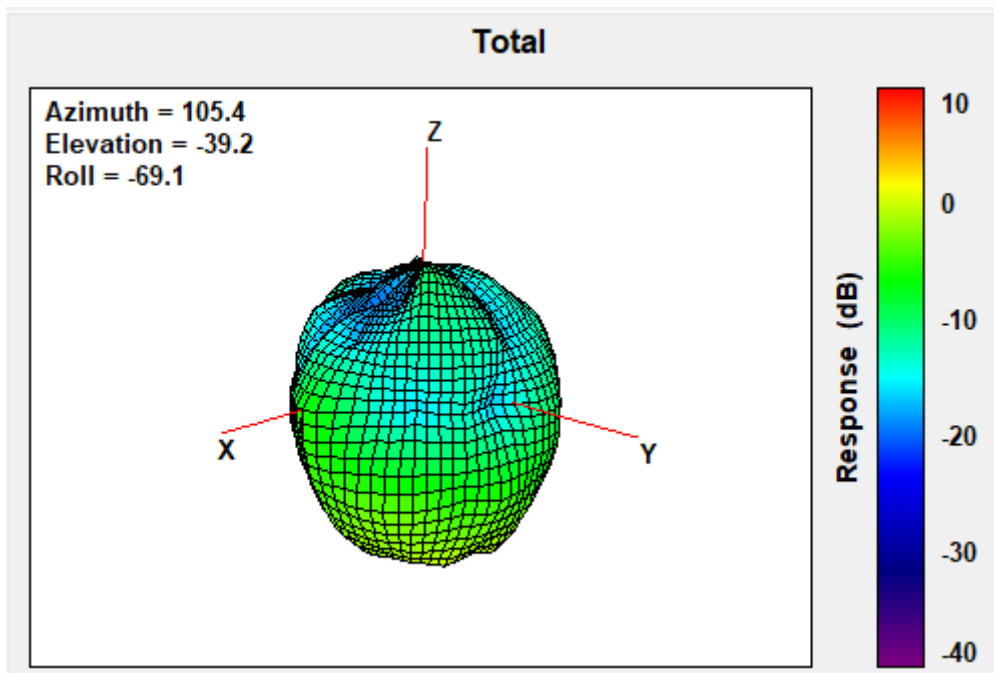

Center Frequency	5925MHz
Horizontal (dBi) peak	-0.99
Vertical (dBi) peak	0.61

TB mode

MIMO2 Antenna (Tx2/Rx3)

1452 MHz

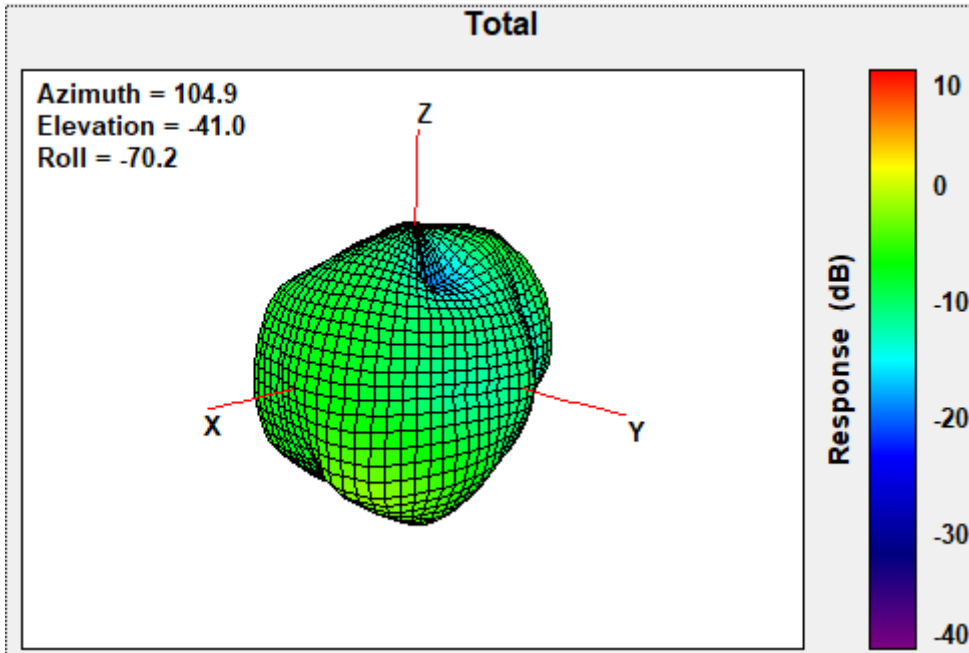

Center Frequency	1452 MHz
Horizontal (dBi) peak	-2.92
Vertical (dBi) peak	-6.04

1474 MHz

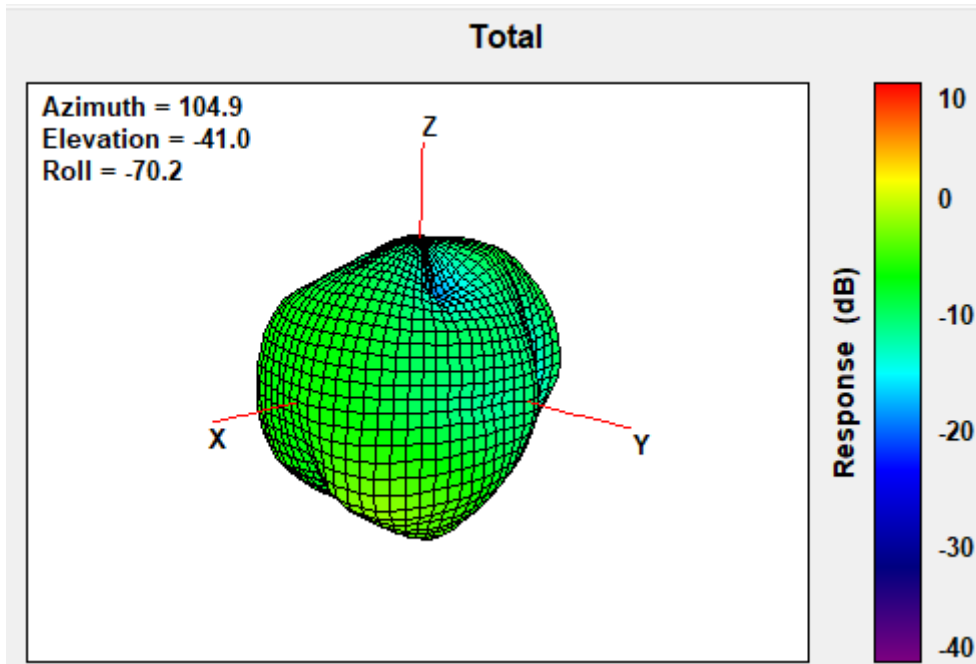

Center Frequency	1474 MHz
Horizontal (dBi) peak	-2.72
Vertical (dBi) peak	-6.05

1496 MHz

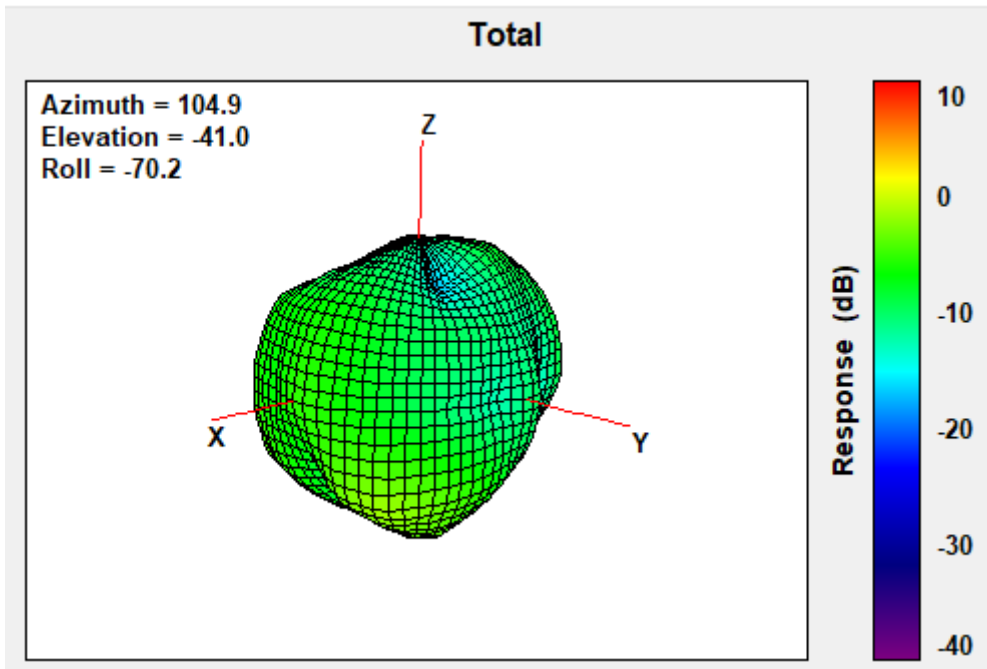

Center Frequency	1496 MHz
Horizontal (dBi) peak	-2.39
Vertical (dBi) peak	-5.10

1710 MHz

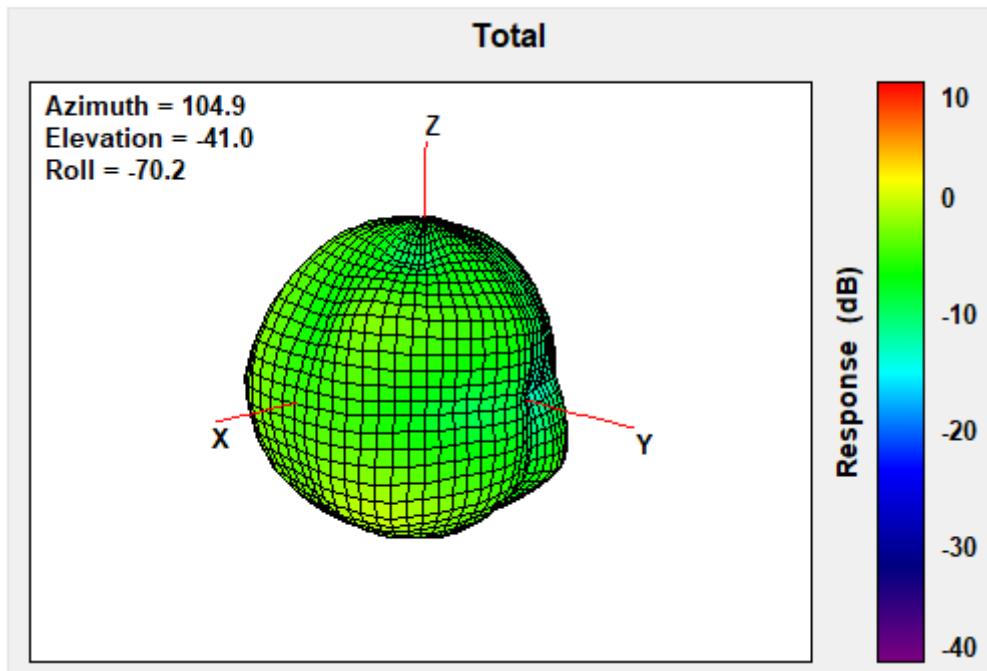

Center Frequency	1710 MHz
Horizontal (dBi) peak	-1.74
Vertical (dBi) peak	-2.28

1732.5 MHz

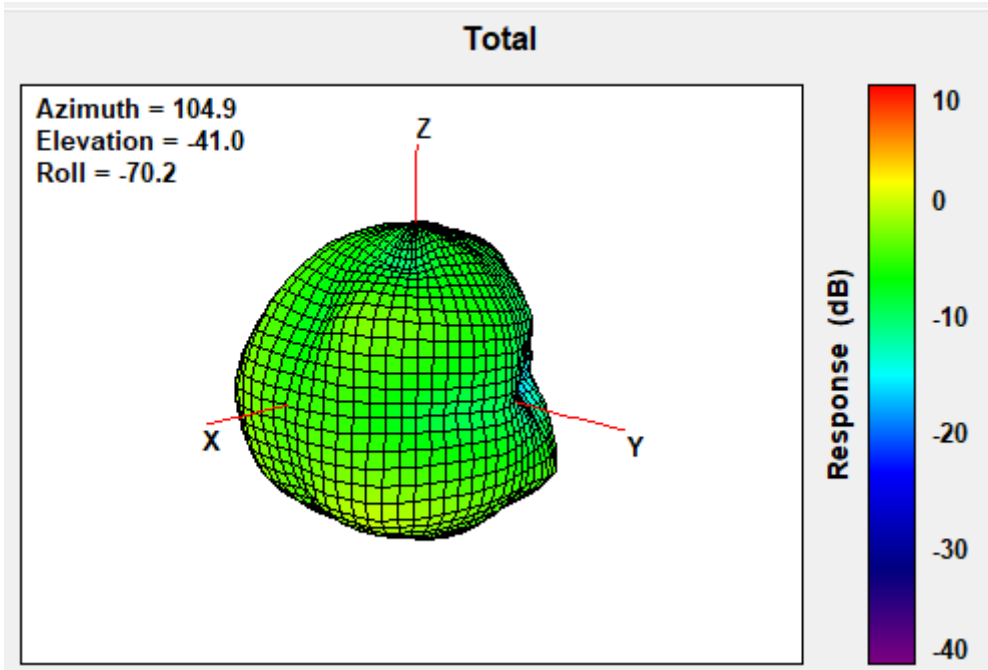

Center Frequency	1732.5 MHz
Horizontal (dBi) peak	-1.75
Vertical (dBi) peak	-2.32

1747.5 MHz

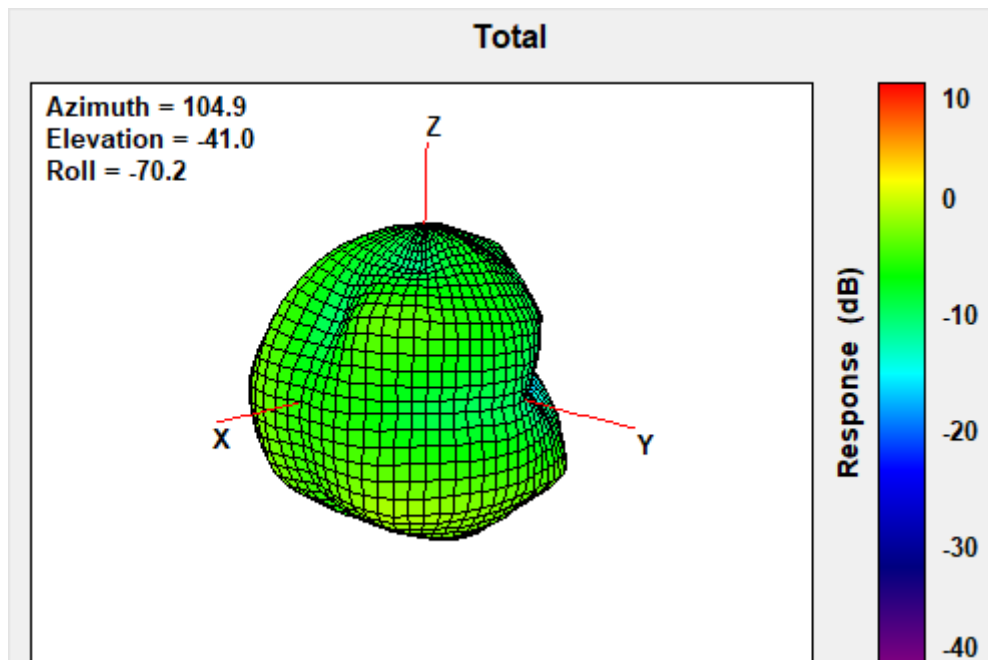

Center Frequency	1747.5 MHz
Horizontal (dBi) peak	-2.43
Vertical (dBi) peak	-3.15

1755 MHz

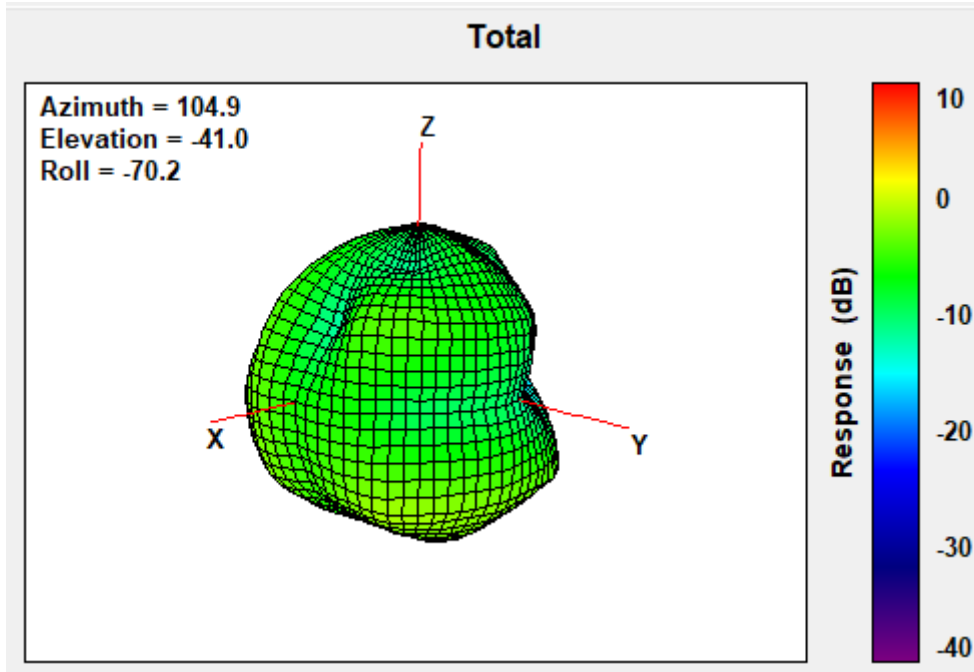

1785 MHz

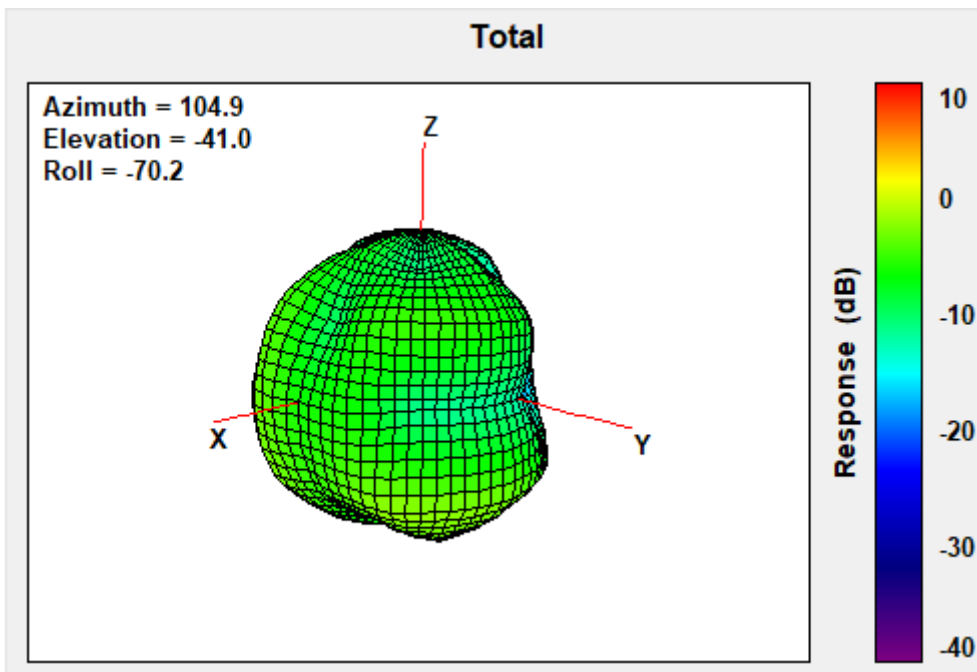

1805 MHz

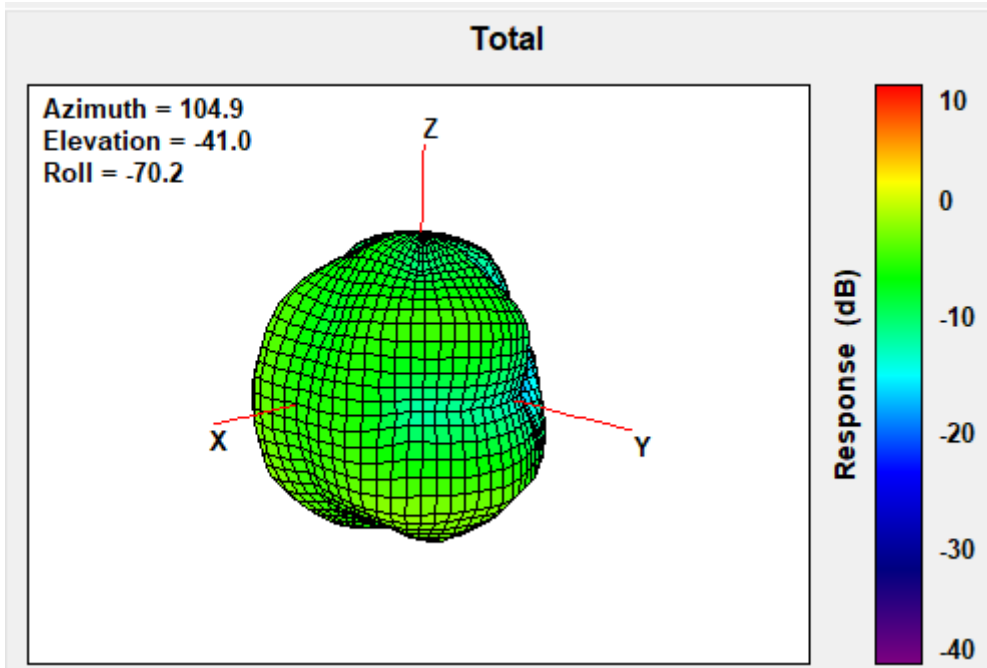

Center Frequency	1805 MHz
Horizontal (dBi) peak	-3.60
Vertical (dBi) peak	-3.35

1850 MHz

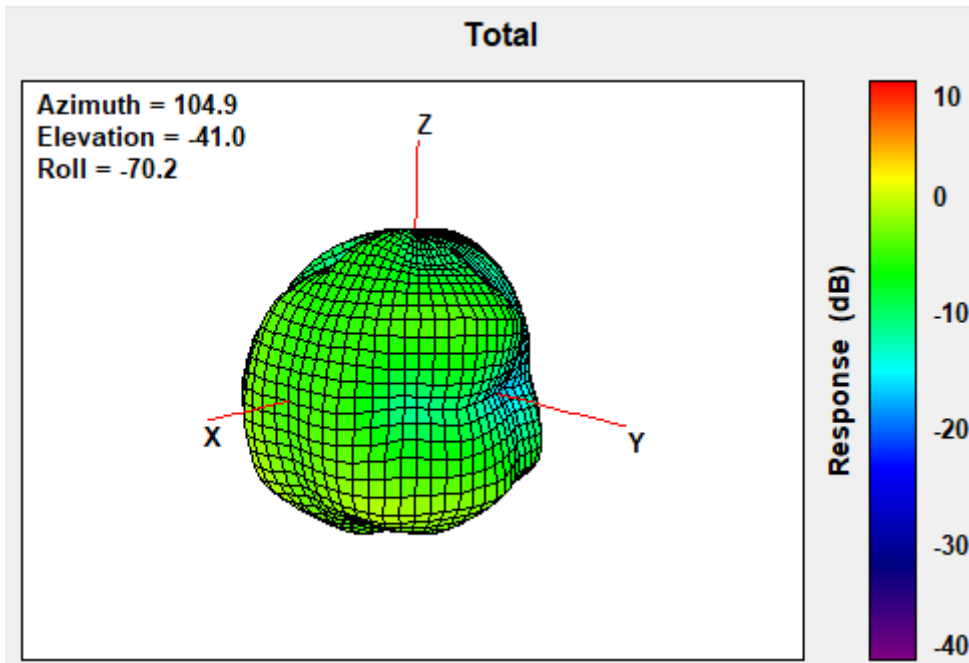

Center Frequency	1850 MHz
Horizontal (dBi) peak	-2.07
Vertical (dBi) peak	-1.55

1880 MHz

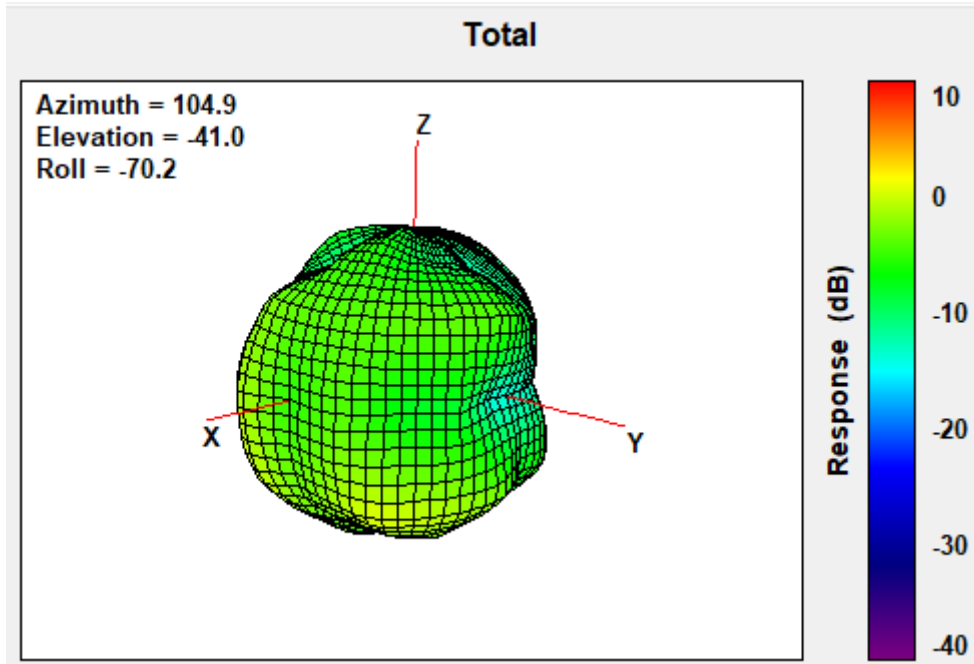

Center Frequency	1880 MHz
Horizontal (dBi) peak	-1.94
Vertical (dBi) peak	-1.98

1910MHz

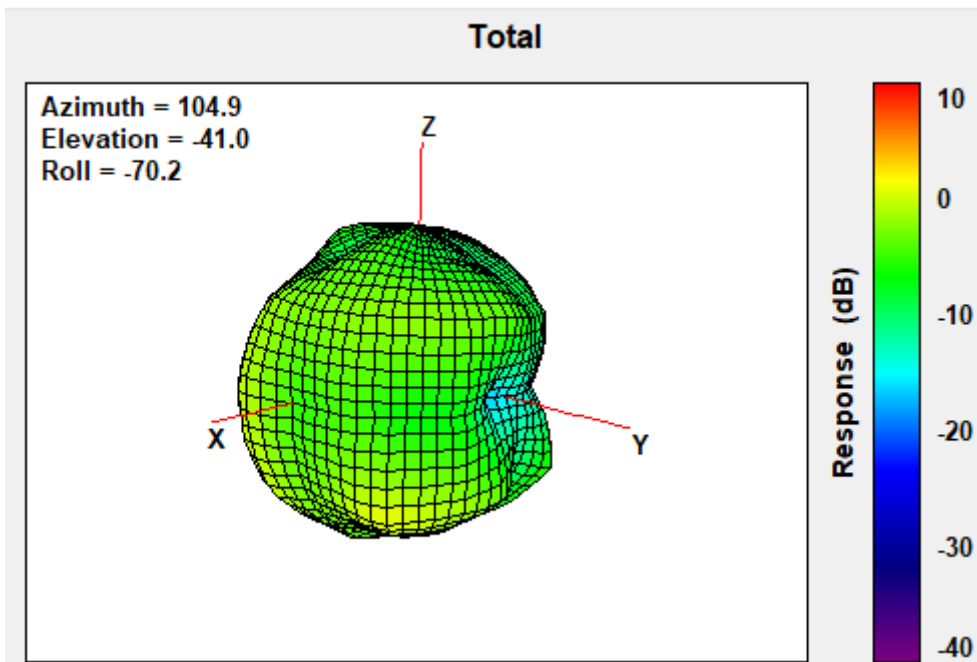

Center Frequency	1910MHz
Horizontal (dBi) peak	-1.38
Vertical (dBi) peak	-1.73

1920MHz

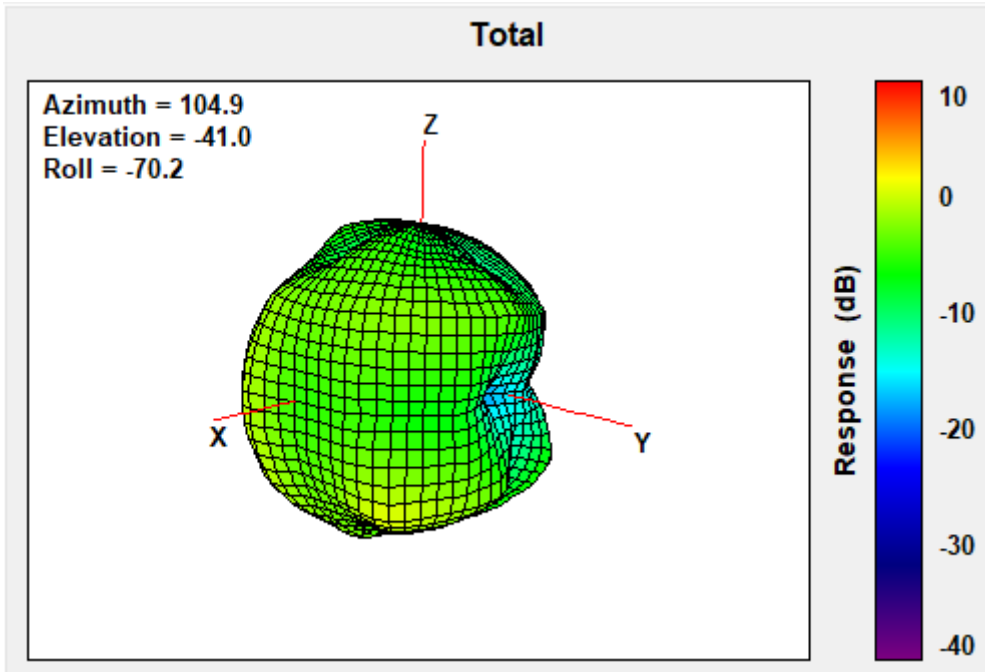

Center Frequency	1920MHz
Horizontal (dBi) peak	-1.73
Vertical (dBi) peak	-1.77

1950MHz

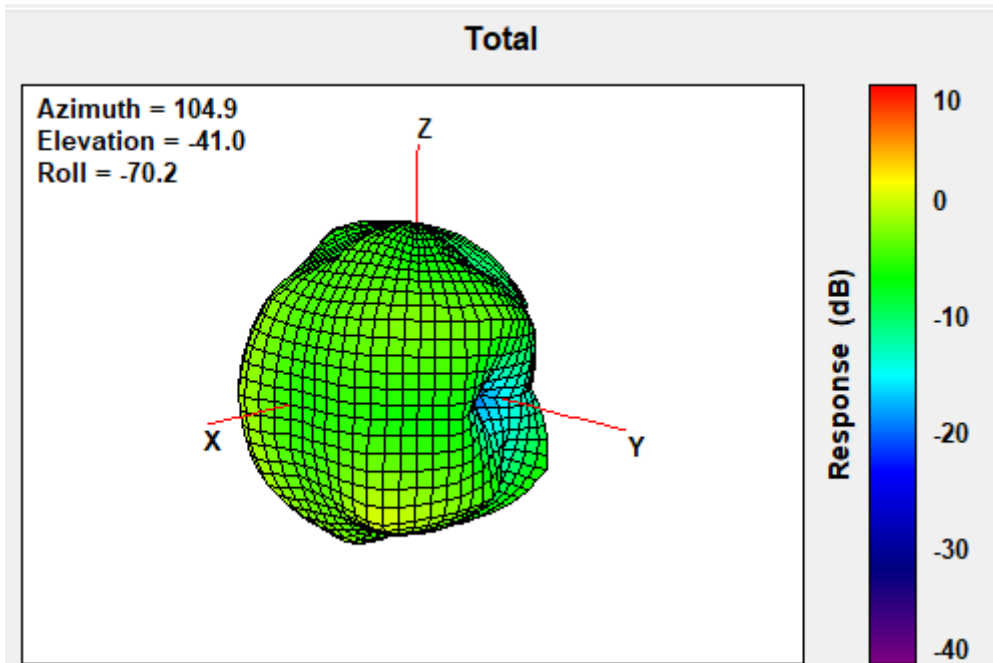

Center Frequency	1950MHz
Horizontal (dBi) peak	-1.81
Vertical (dBi) peak	-0.79

1980MHz

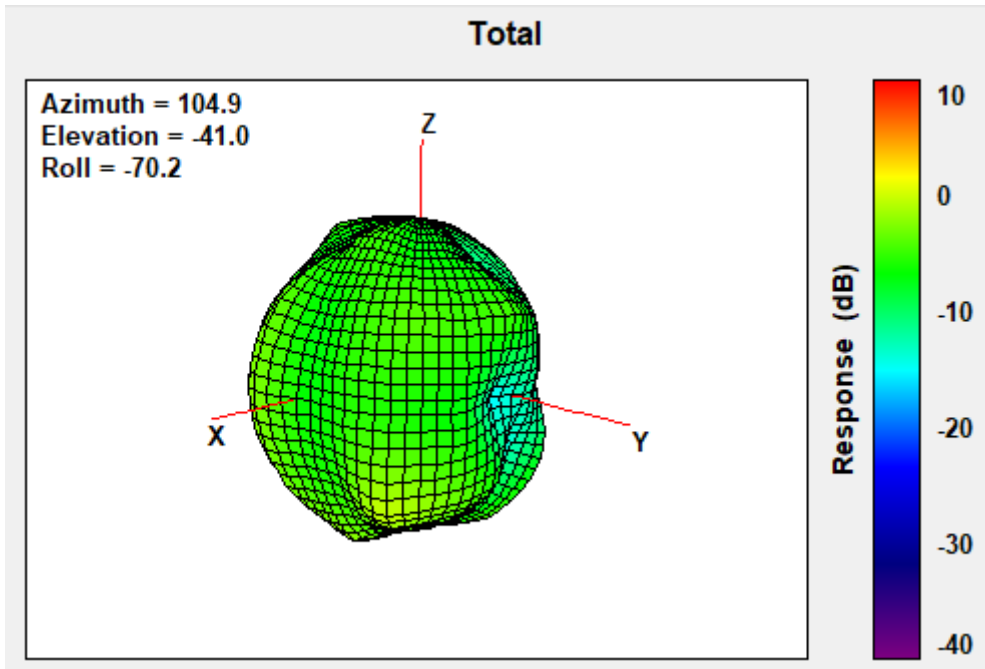

Center Frequency	1980MHz
Horizontal (dBi) peak	-1.53
Vertical (dBi) peak	-2.27

2110MHz

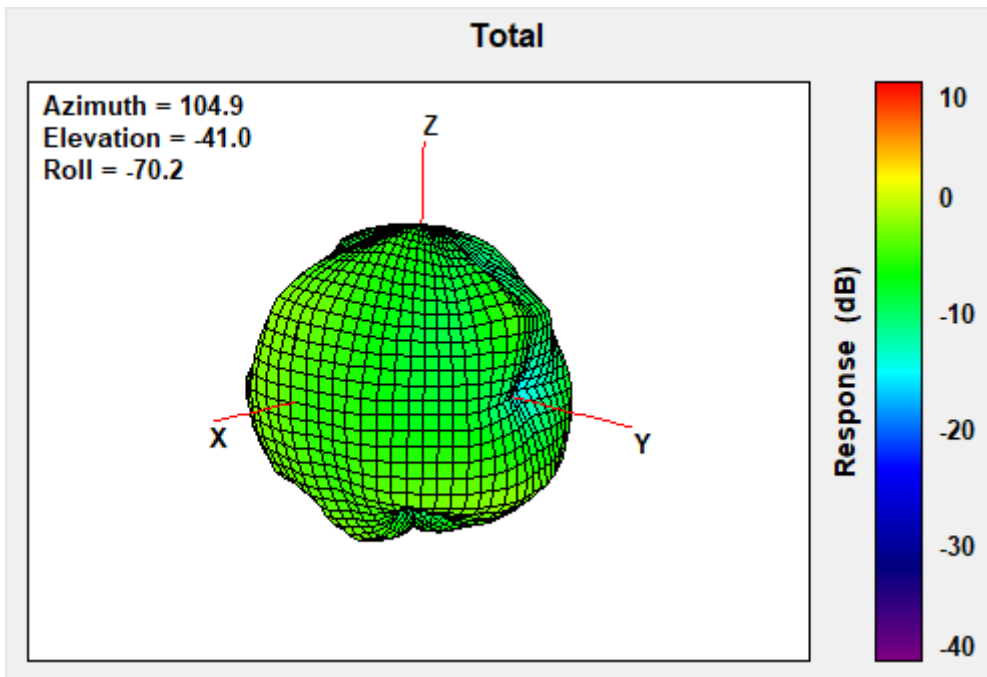

Center Frequency	2110MHz
Horizontal (dBi) peak	-3.00
Vertical (dBi) peak	-2.50

2200MHz

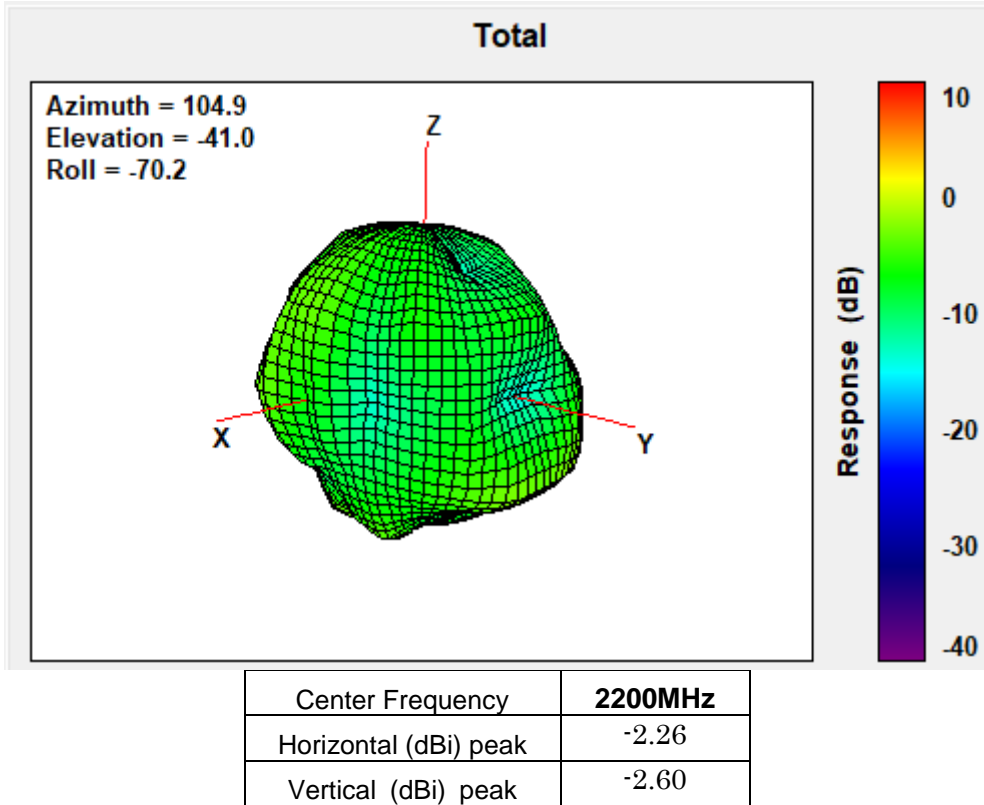

2300MHz

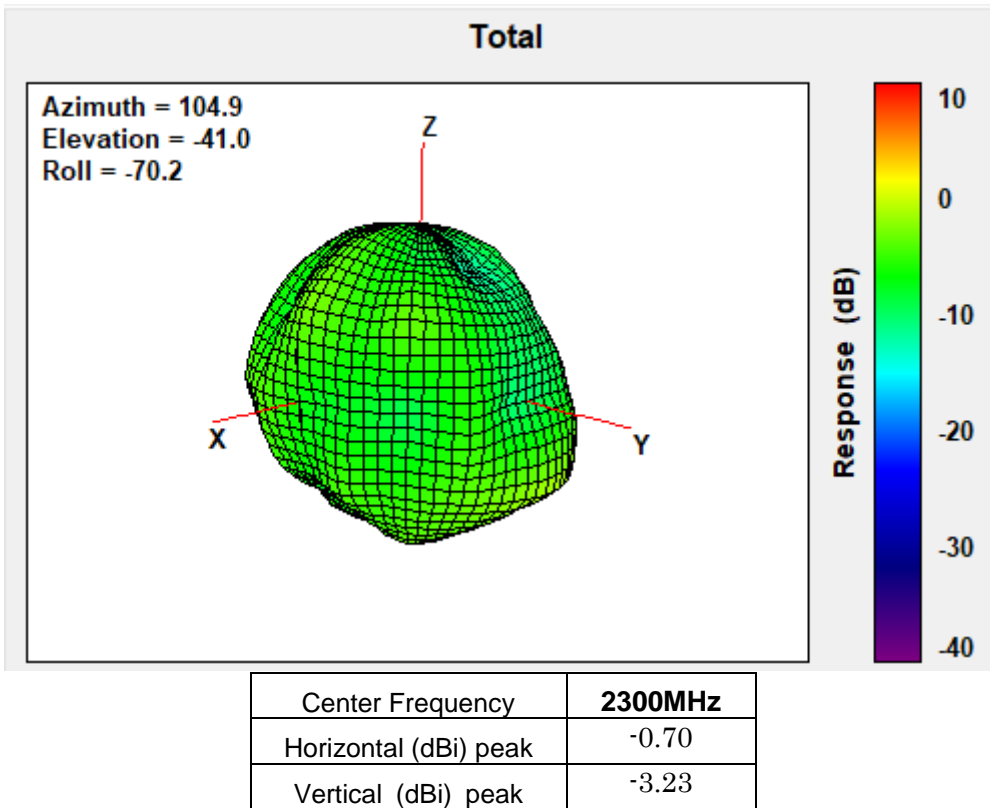

2305MHz

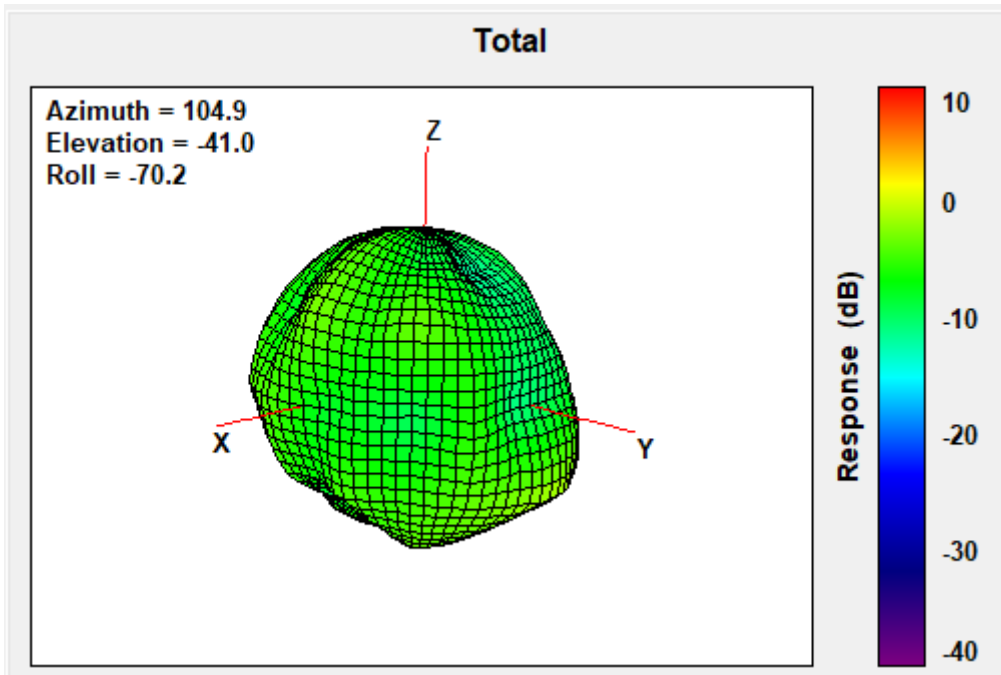

Center Frequency	2305MHz
Horizontal (dBi) peak	-0.63
Vertical (dBi) peak	-3.34

2315MHz

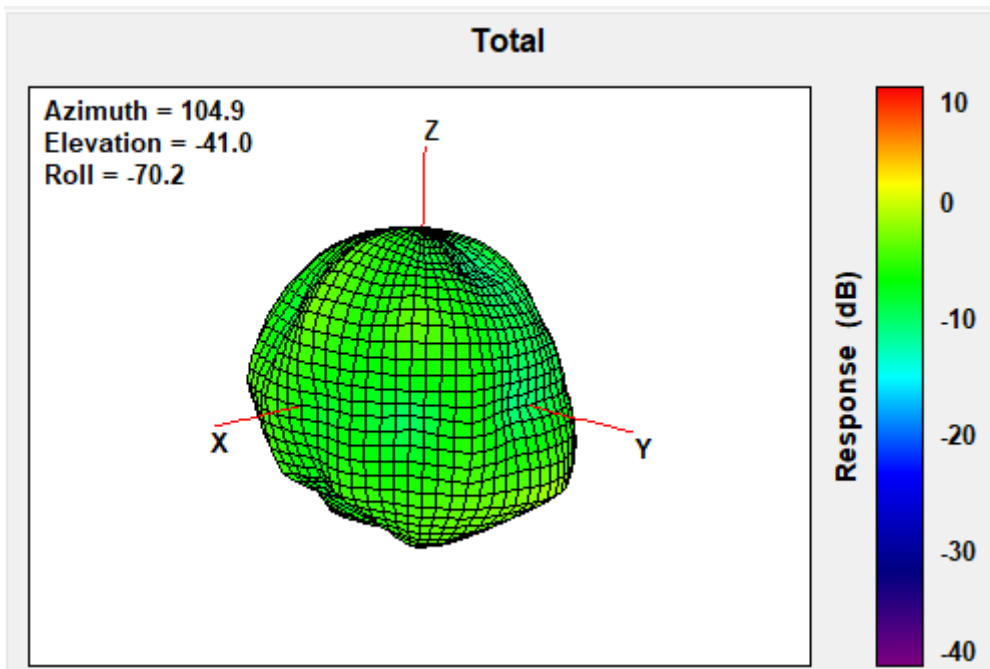

Center Frequency	2315MHz
Horizontal (dBi) peak	-0.58
Vertical (dBi) peak	-3.29

2350MHz

Total

Azimuth = 104.9
 Elevation = -41.0
 Roll = -70.2

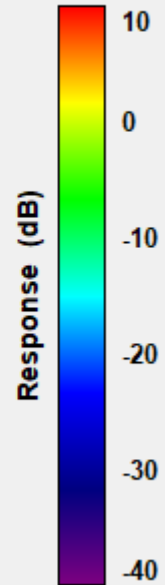
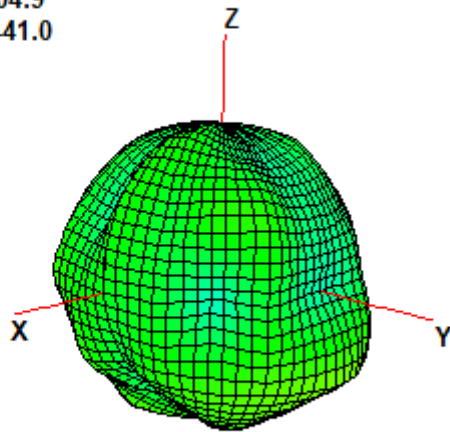

Center Frequency	2350MHz
Horizontal (dBi) peak	-2.18
Vertical (dBi) peak	-4.72

2400MHz

Total

Azimuth = 104.9
 Elevation = -41.0
 Roll = -70.2

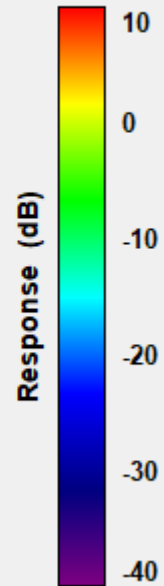
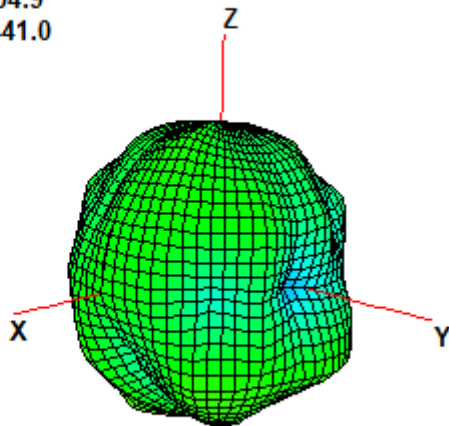

Center Frequency	2400MHz
Horizontal (dBi) peak	-4.91
Vertical (dBi) peak	-4.17

2500MHz

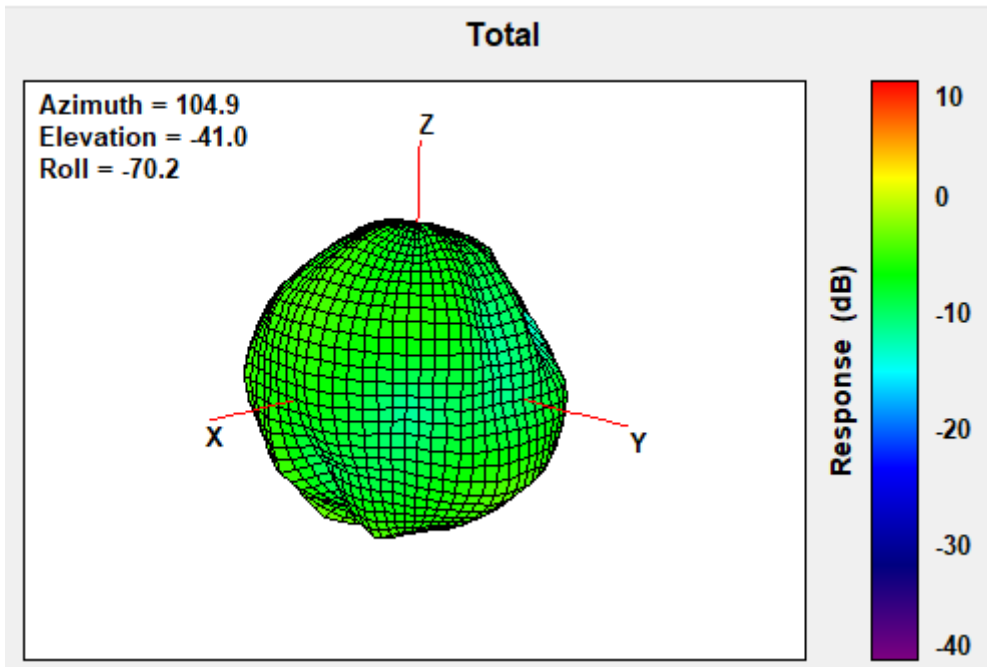

Center Frequency	2500MHz
Horizontal (dBi) peak	-3.62
Vertical (dBi) peak	-2.14

2570MHz

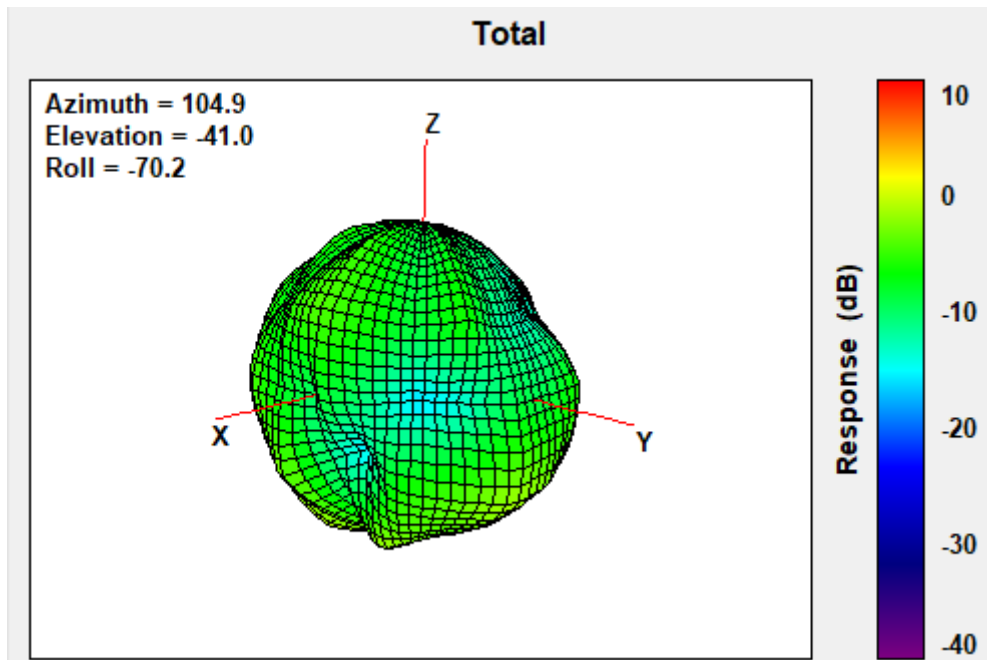

Center Frequency	2570MHz
Horizontal (dBi) peak	-1.26
Vertical (dBi) peak	0.02

2595MHz

Total

Azimuth = 104.9
 Elevation = -41.0
 Roll = -70.2

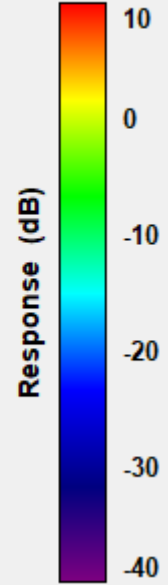
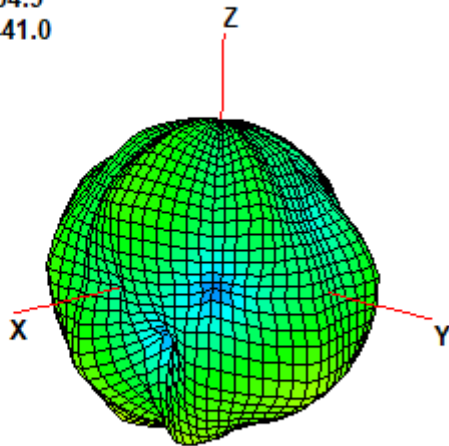

Center Frequency	2595MHz
Horizontal (dBi) peak	-0.98
Vertical (dBi) peak	0.33

2620MHz

Total

Azimuth = 104.9
 Elevation = -41.0
 Roll = -70.2

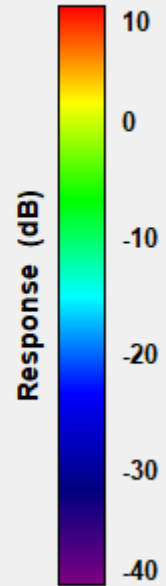
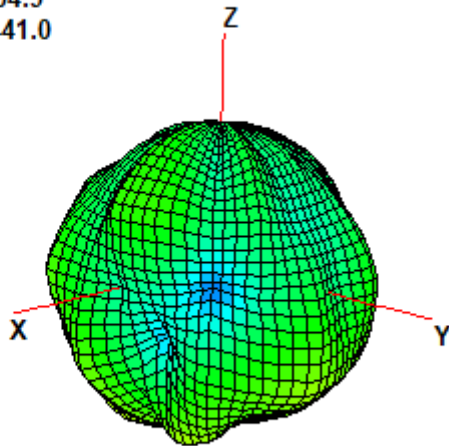

Center Frequency	2620MHz
Horizontal (dBi) peak	-1.17
Vertical (dBi) peak	0.23

2690MHz

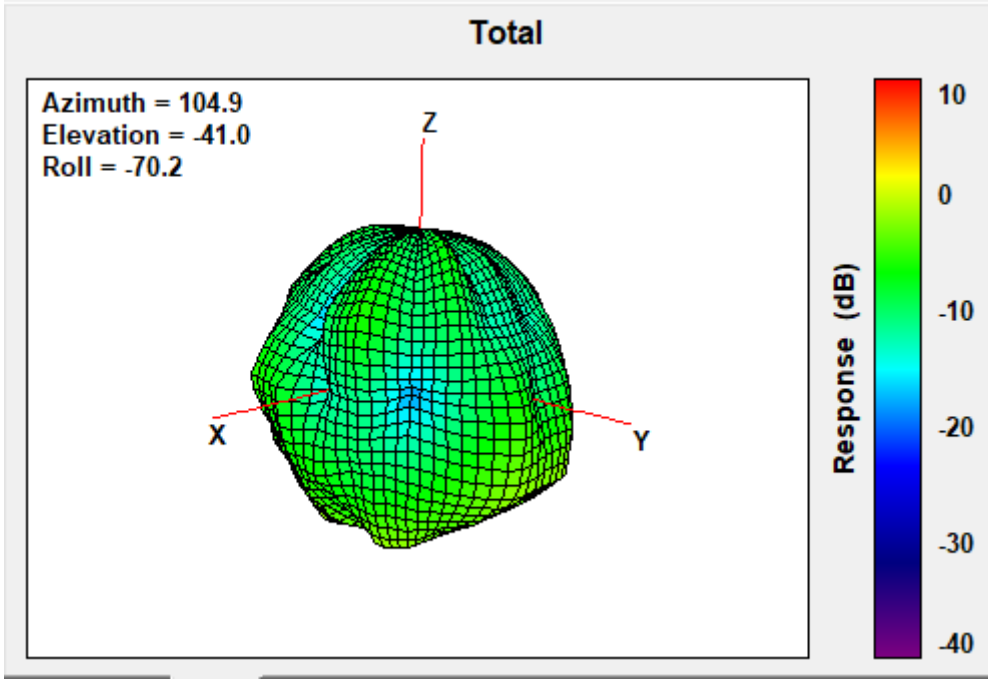

Center Frequency	2690MHz
Horizontal (dBi) peak	-1.44
Vertical (dBi) peak	-1.30

3400MHz

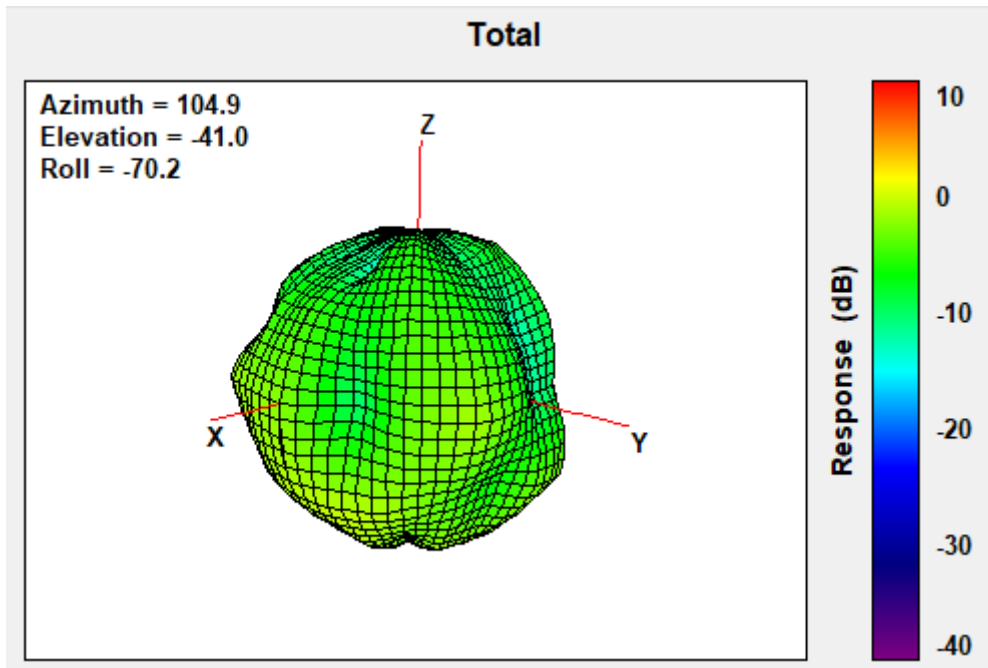

Center Frequency	3400MHz
Horizontal (dBi) peak	0.43
Vertical (dBi) peak	-1.50

3500MHz

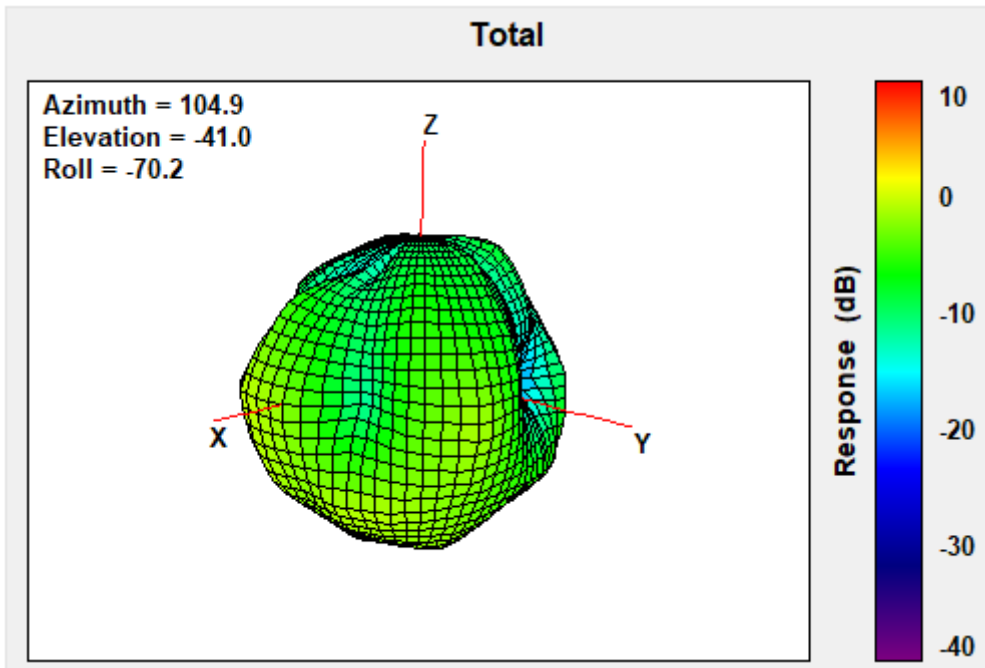

Center Frequency	3500MHz
Horizontal (dBi) peak	-0.83
Vertical (dBi) peak	-1.22

3600MHz

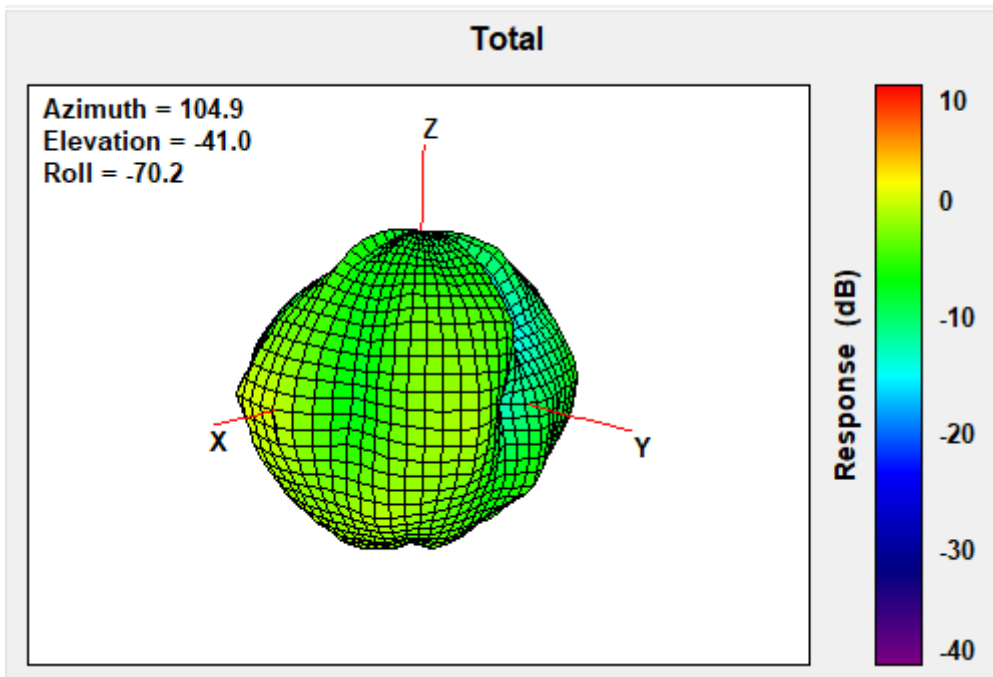

Center Frequency	3600MHz
Horizontal (dBi) peak	-0.50
Vertical (dBi) peak	-0.56

3700MHz

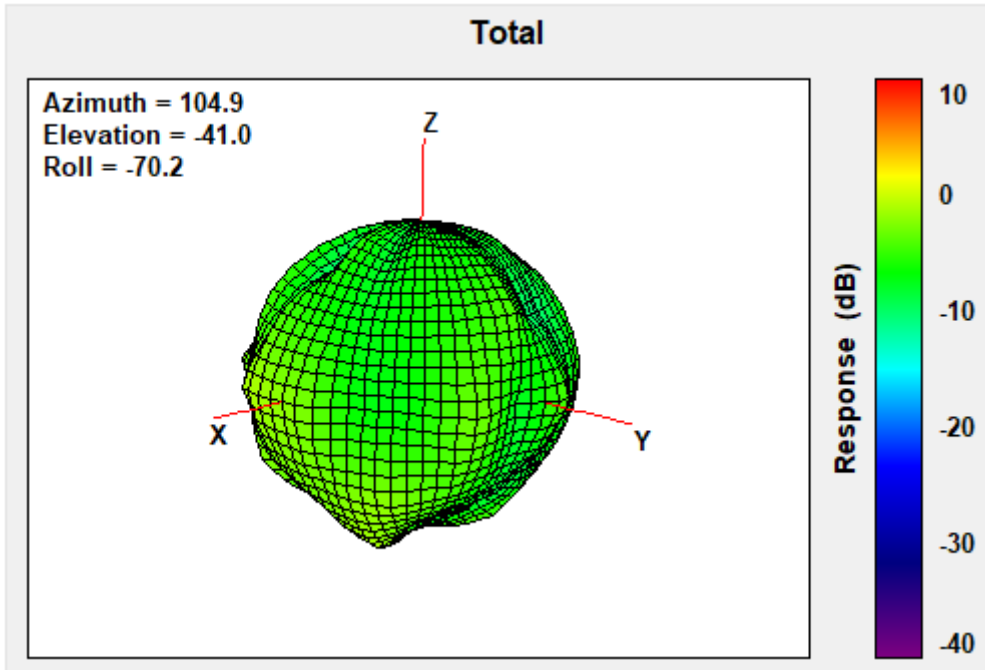

Center Frequency	3700MHz
Horizontal (dBi) peak	-1.28
Vertical (dBi) peak	-0.70

3800MHz

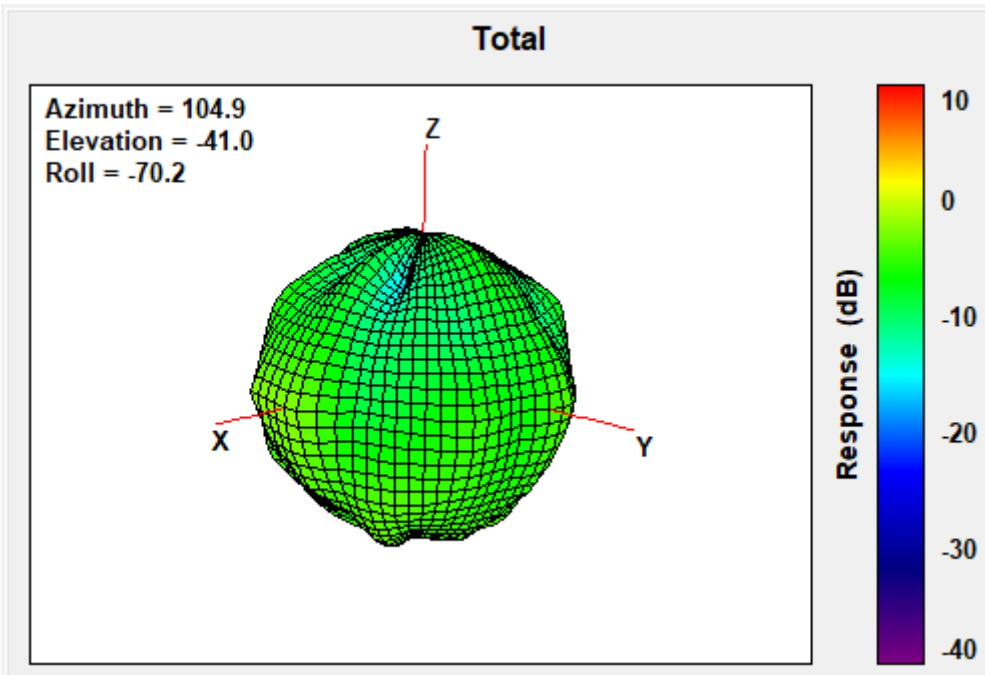

Center Frequency	3800MHz
Horizontal (dBi) peak	-1.67
Vertical (dBi) peak	-3.45

4200MHz

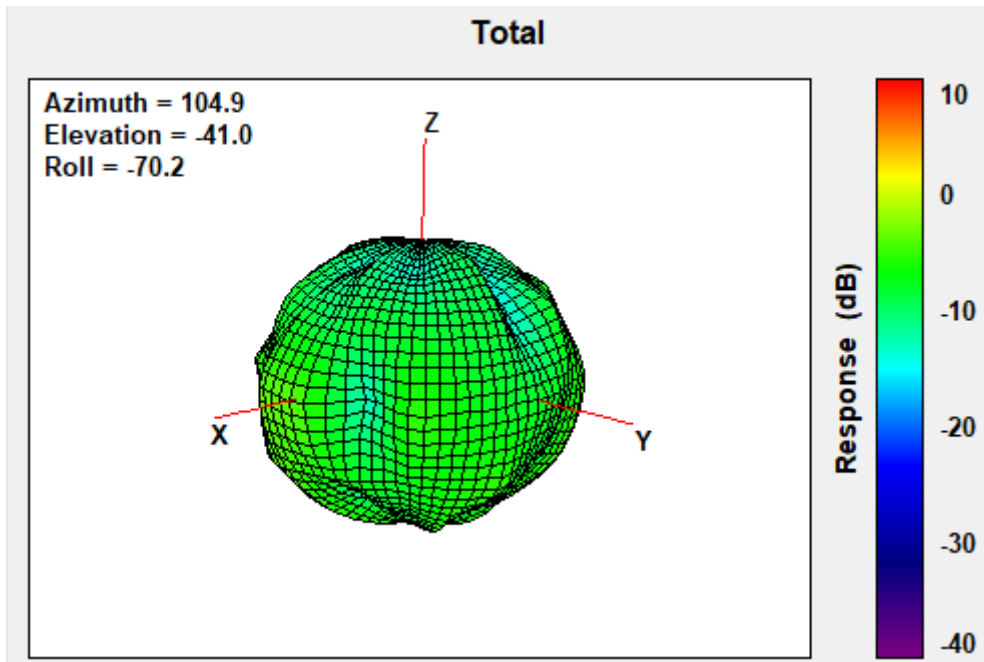

Center Frequency	4200MHz
Horizontal (dBi) peak	-0.69
Vertical (dBi) peak	-1.53

4400MHz

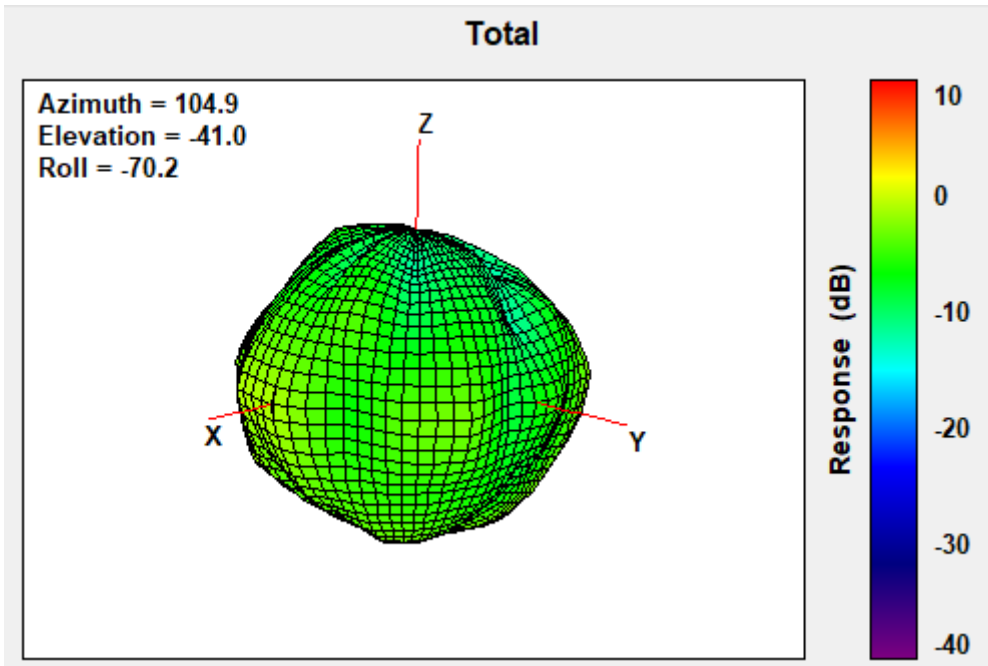

Center Frequency	4400MHz
Horizontal (dBi) peak	-0.18
Vertical (dBi) peak	0.35

4700MHz

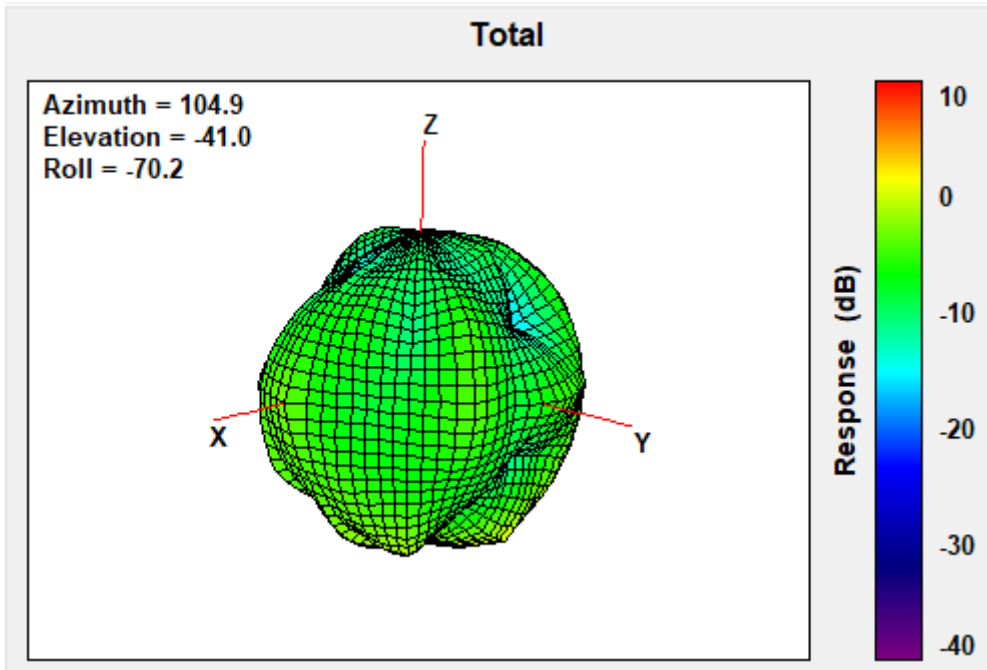

Center Frequency	4700MHz
Horizontal (dBi) peak	-1.22
Vertical (dBi) peak	-1.04

5000MHz

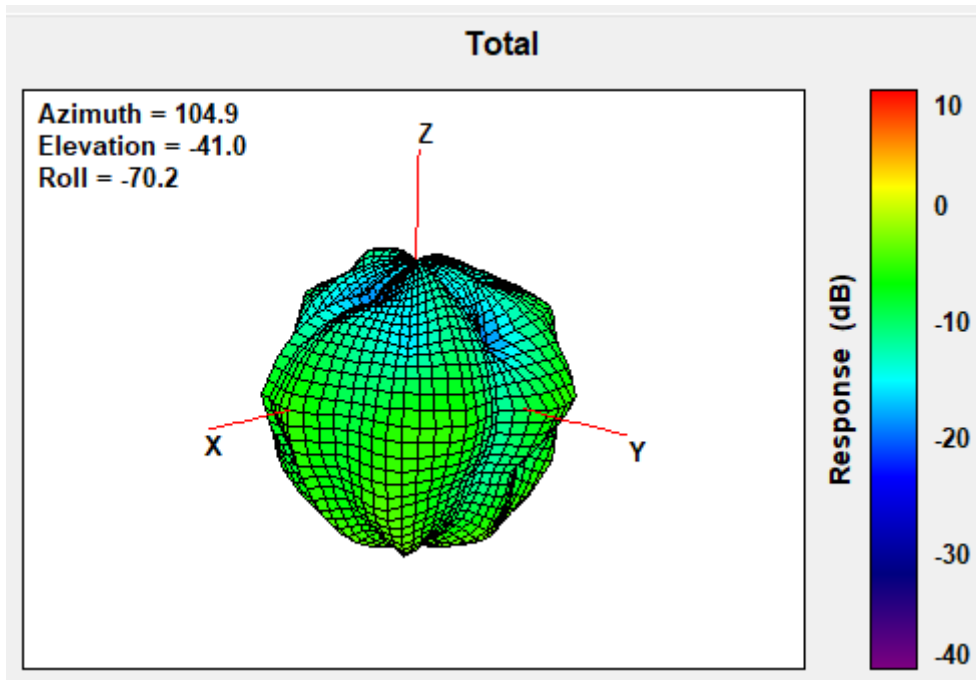

Center Frequency	5000MHz
Horizontal (dBi) peak	-1.11
Vertical (dBi) peak	-0.19

TB mode MIMO3 Antenna (Rx4)

1805 MHz

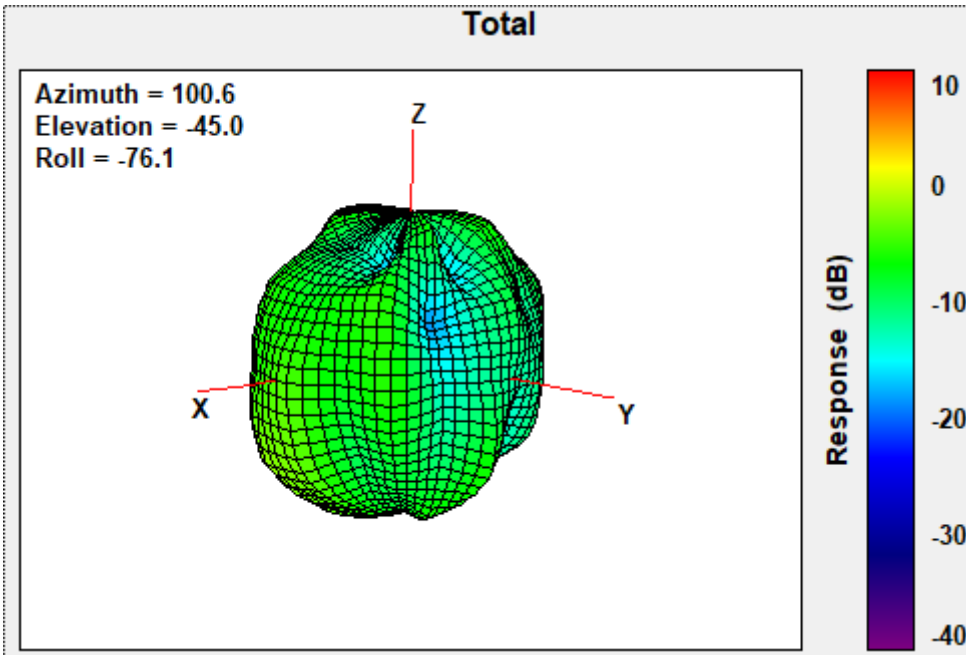

Center Frequency	1805 MHz
Horizontal (dBi) peak	0.17
Vertical (dBi) peak	-3.90

1850 MHz

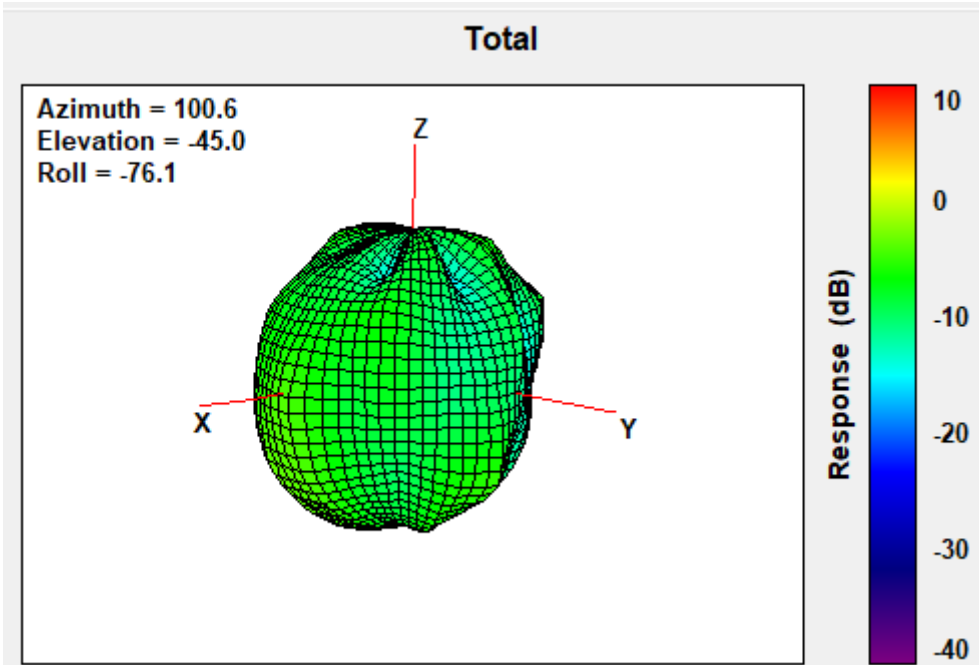

Center Frequency	1850 MHz
Horizontal (dBi) peak	-1.54
Vertical (dBi) peak	-4.55

1880 MHz

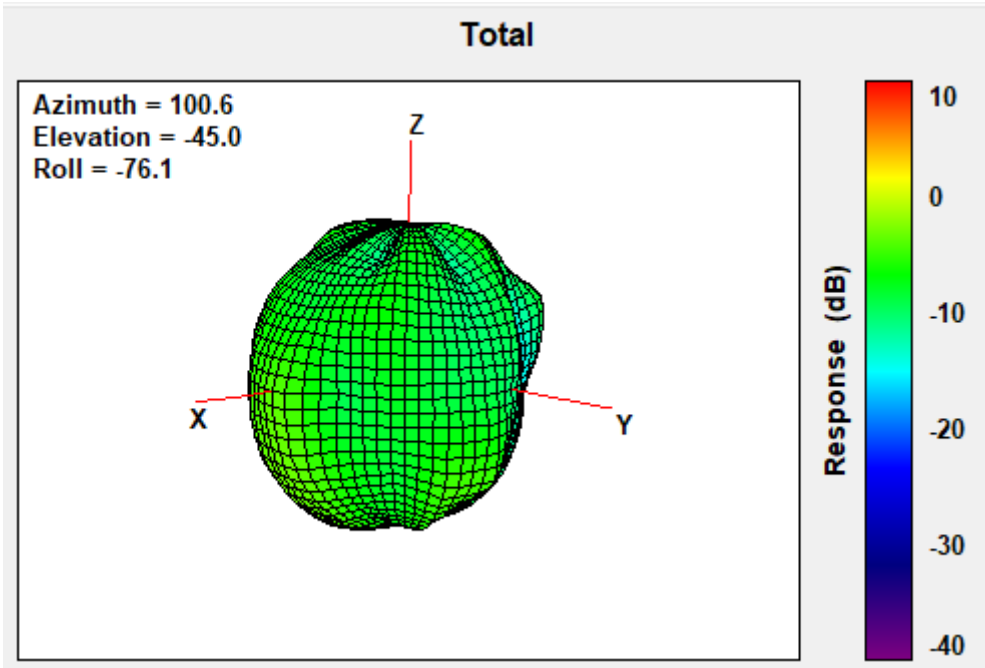

Center Frequency	1880 MHz
Horizontal (dBi) peak	-1.13
Vertical (dBi) peak	-4.53

1910MHz

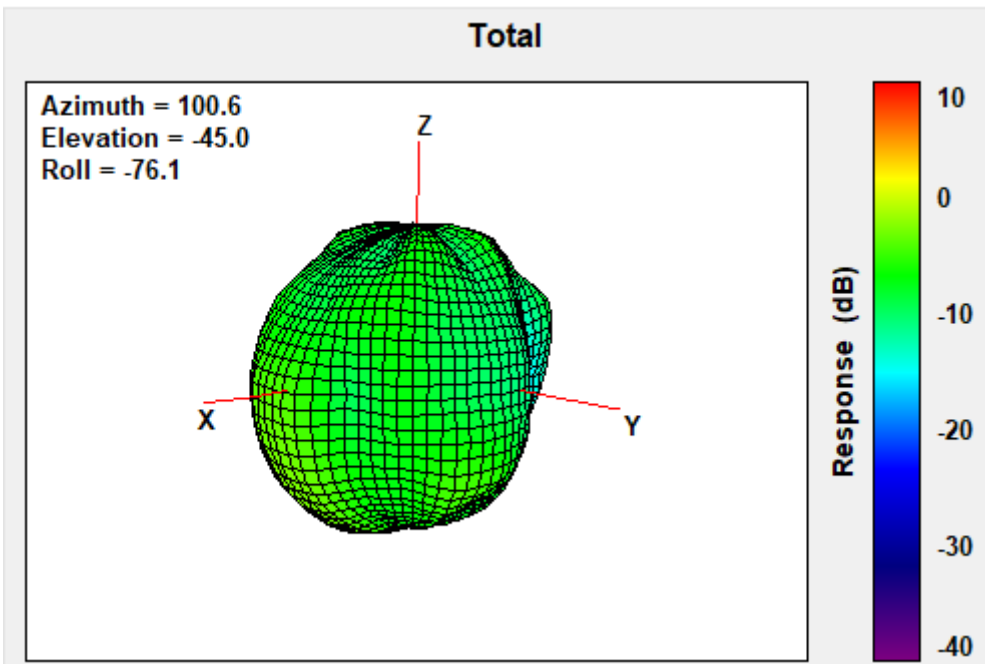

Center Frequency	1910MHz
Horizontal (dBi) peak	-0.46
Vertical (dBi) peak	-4.48

1920MHz

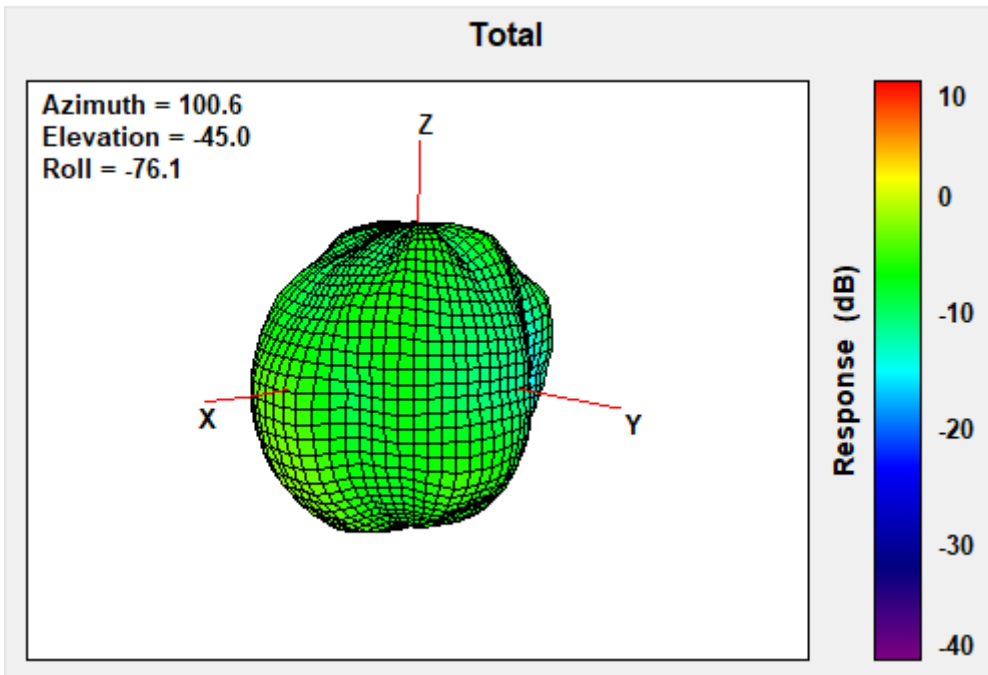

Center Frequency	1920MHz
Horizontal (dBi) peak	-0.36
Vertical (dBi) peak	-4.31

1950MHz

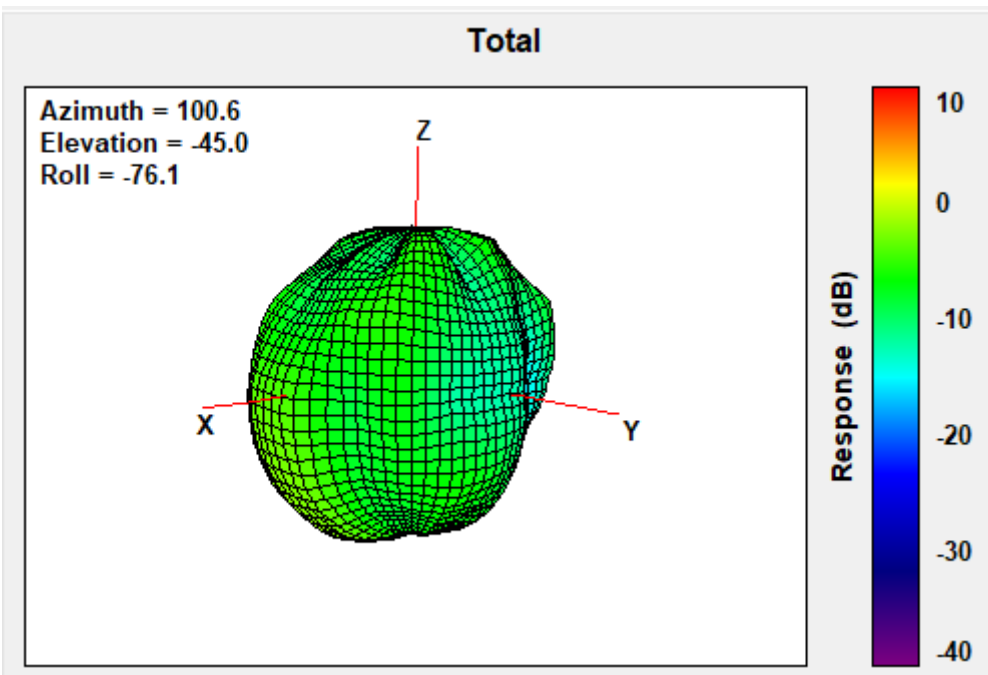

Center Frequency	1950MHz
Horizontal (dBi) peak	0.30
Vertical (dBi) peak	-3.91

1980MHz

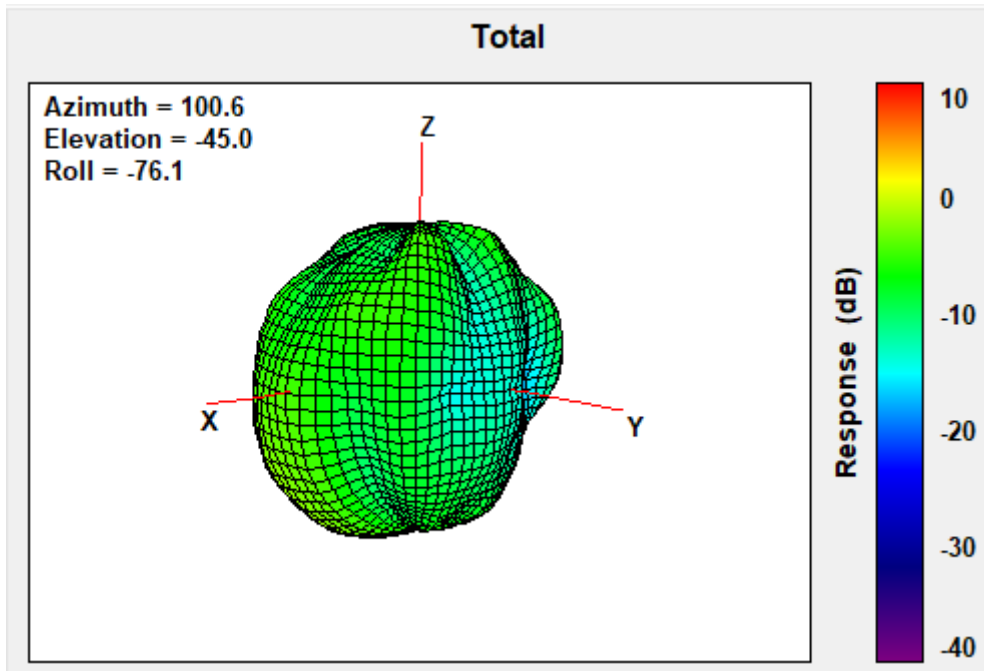

Center Frequency	1980MHz
Horizontal (dBi) peak	0.52
Vertical (dBi) peak	-2.70

2110MHz

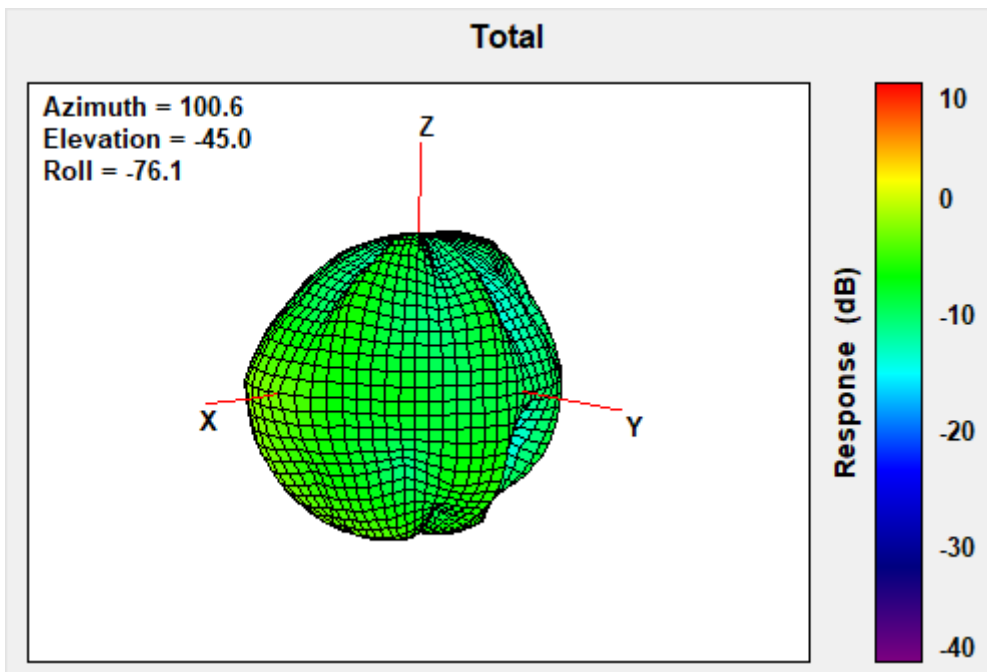

Center Frequency	2110MHz
Horizontal (dBi) peak	-0.50
Vertical (dBi) peak	-2.34

2200MHz

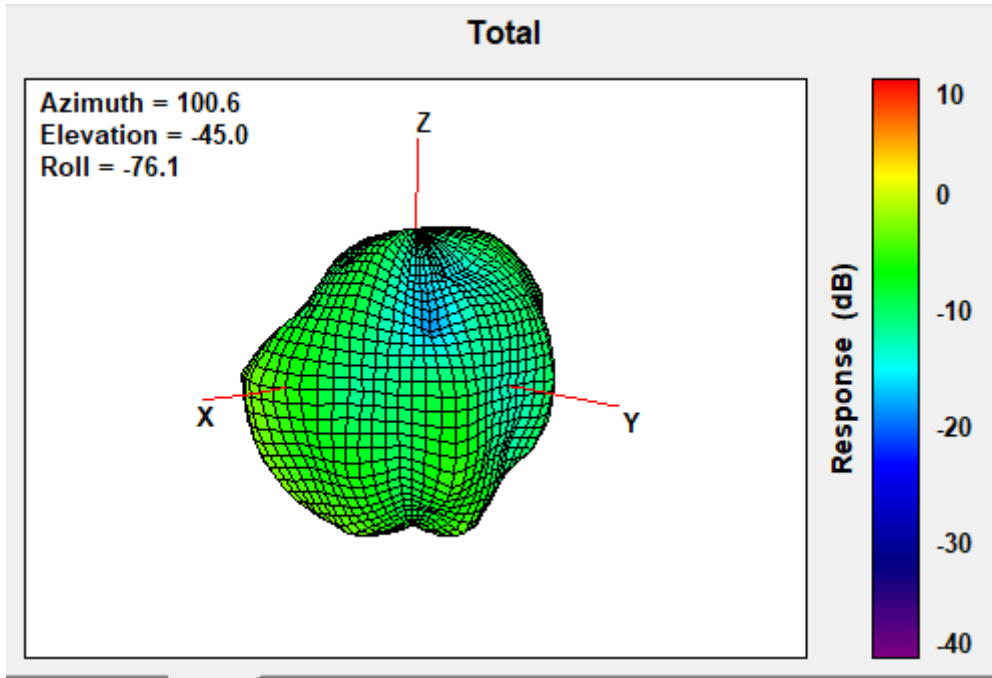

Center Frequency	2200MHz
Horizontal (dBi) peak	-0.05
Vertical (dBi) peak	-0.89

2300MHz

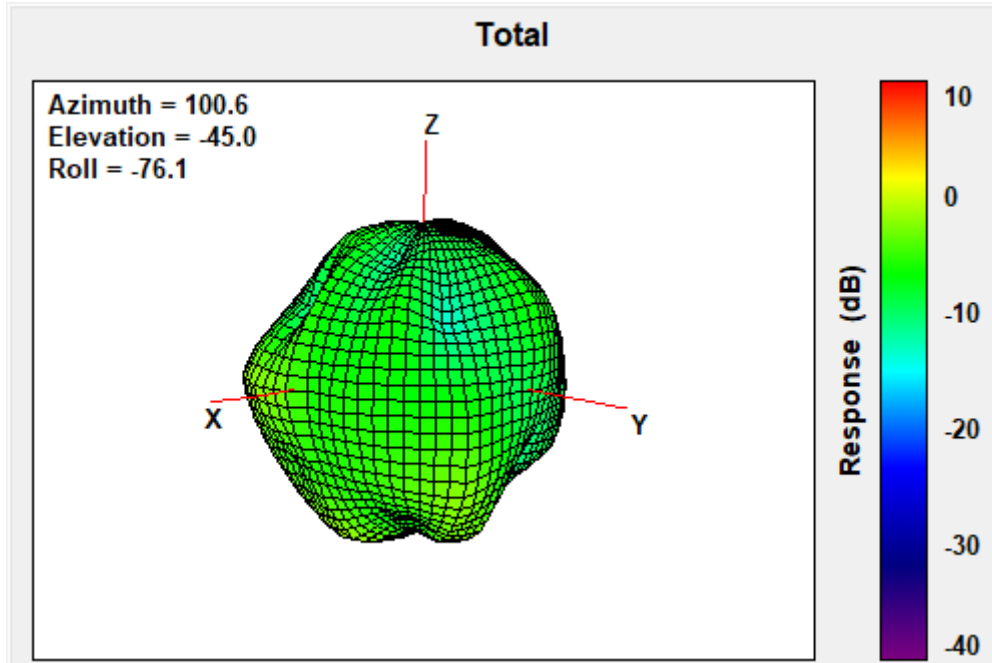

Center Frequency	2300MHz
Horizontal (dBi) peak	-0.49
Vertical (dBi) peak	-3.61

2305MHz

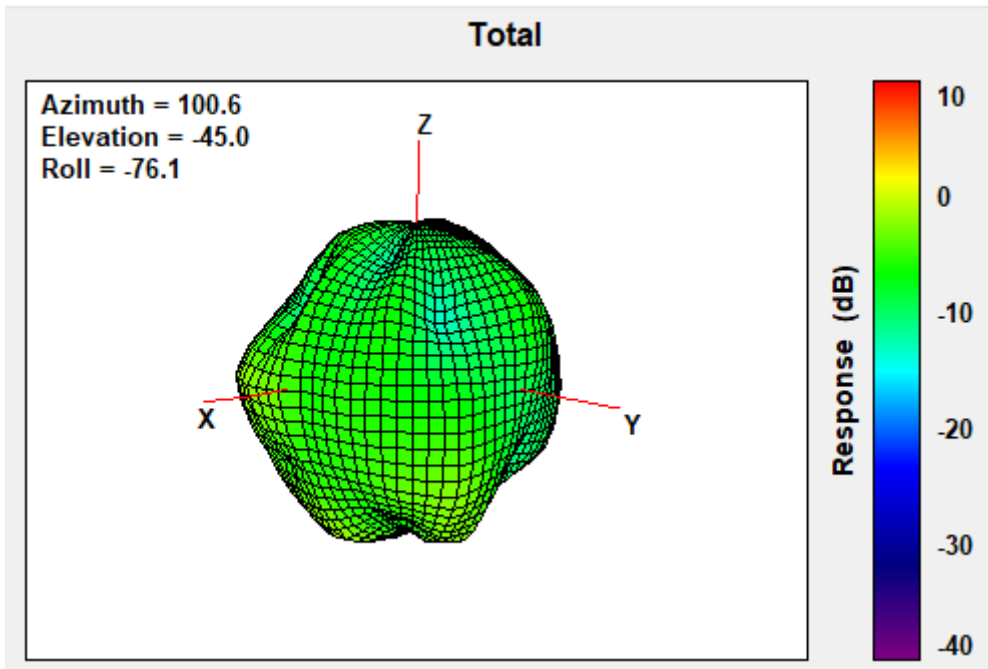

Center Frequency	2305MHz
Horizontal (dBi) peak	-0.40
Vertical (dBi) peak	-3.56

2315MHz

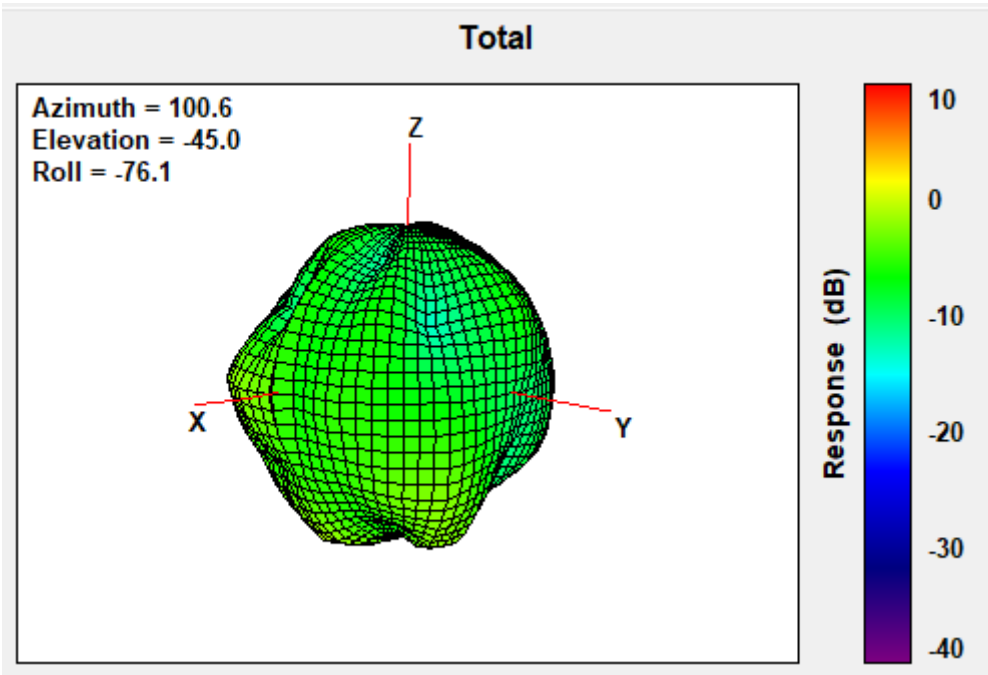

Center Frequency	2315MHz
Horizontal (dBi) peak	-0.30
Vertical (dBi) peak	-3.49

2350MHz

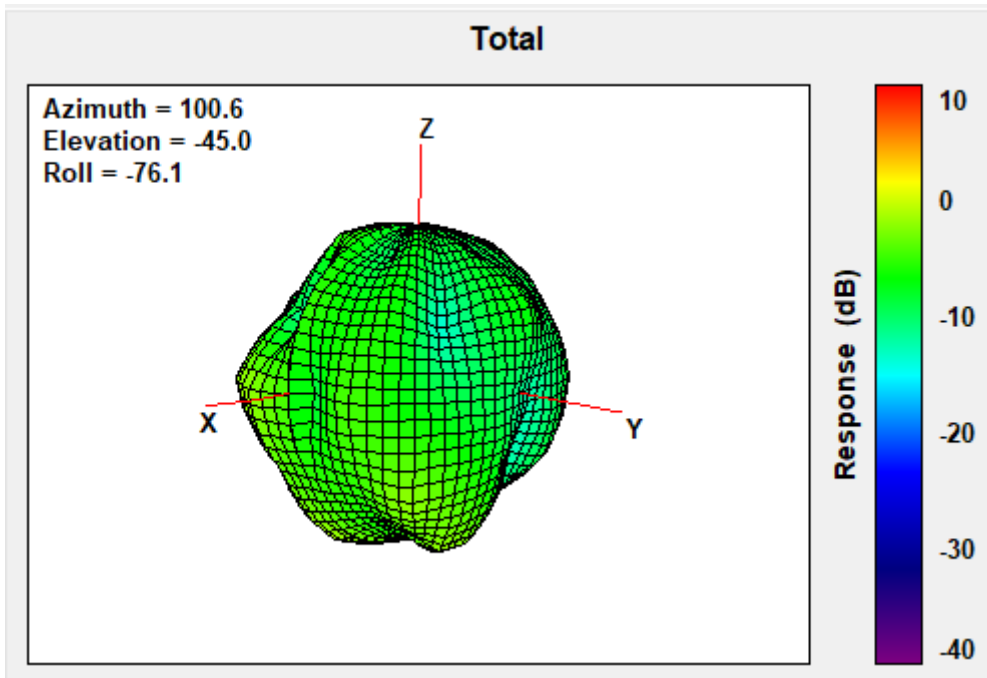

Center Frequency	2350MHz
Horizontal (dBi) peak	-0.68
Vertical (dBi) peak	-3.10

2400MHz

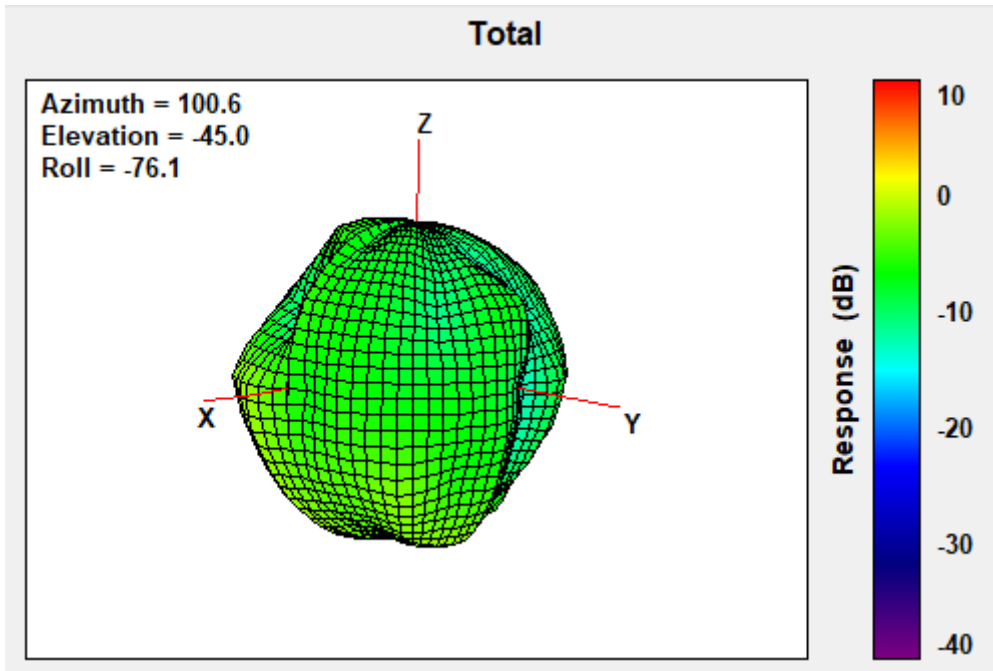

Center Frequency	2400MHz
Horizontal (dBi) peak	-0.95
Vertical (dBi) peak	-1.87

2500MHz

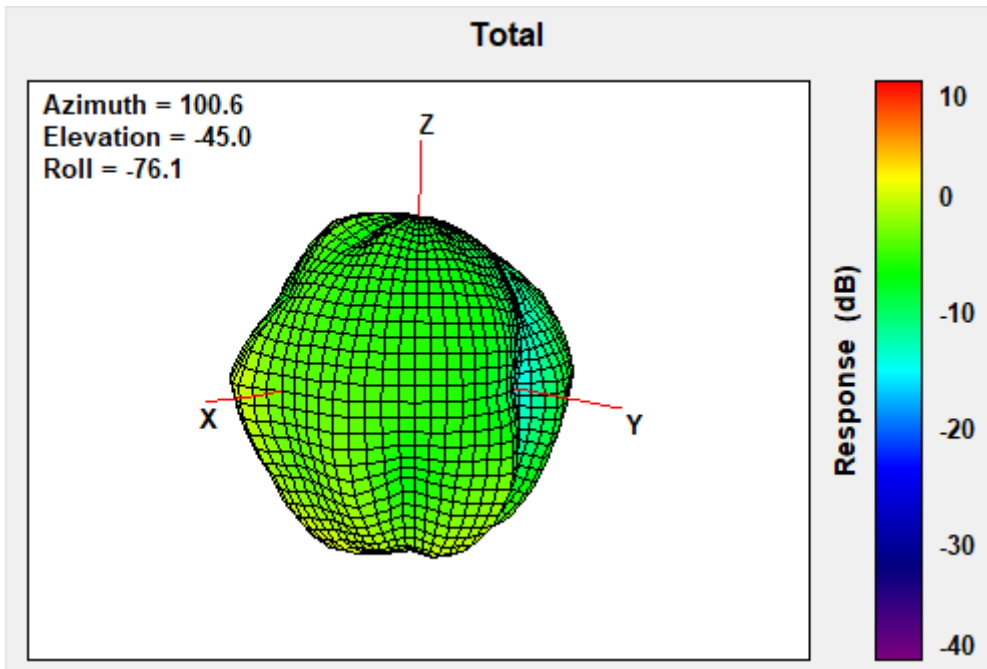

Center Frequency	2500MHz
Horizontal (dBi) peak	1.93
Vertical (dBi) peak	0.24

2570MHz

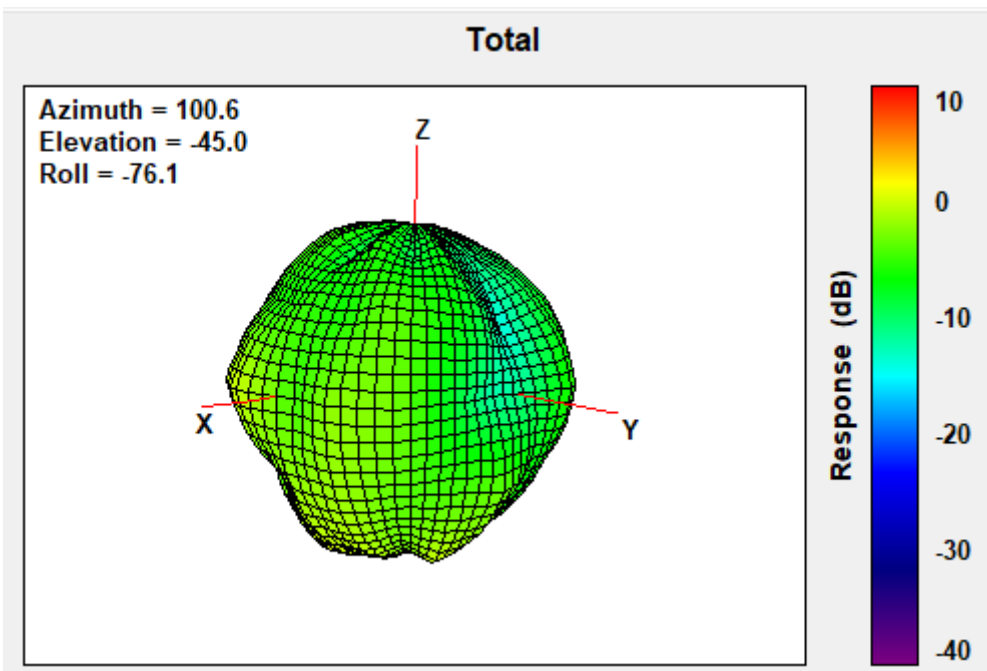

Center Frequency	2570MHz
Horizontal (dBi) peak	0.56
Vertical (dBi) peak	0.28

2595MHz

Total

Azimuth = 100.6
 Elevation = -45.0
 Roll = -76.1

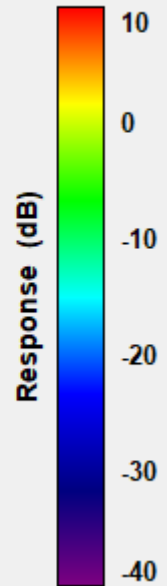
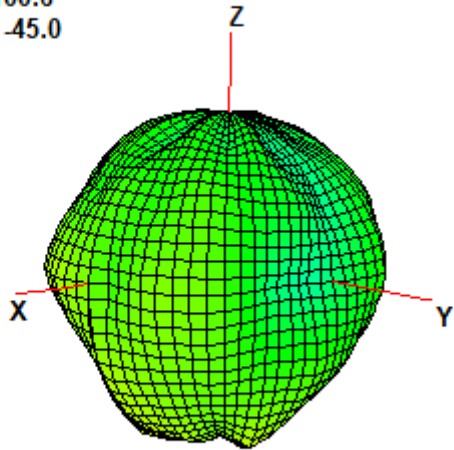

Center Frequency	2595MHz
Horizontal (dBi) peak	-0.24
Vertical (dBi) peak	0.21

2620MHz

Total

Azimuth = 100.6
 Elevation = -45.0
 Roll = -76.1

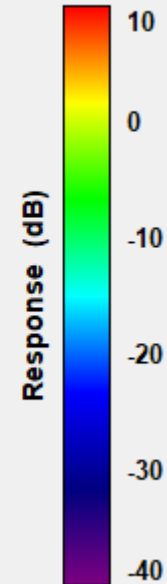
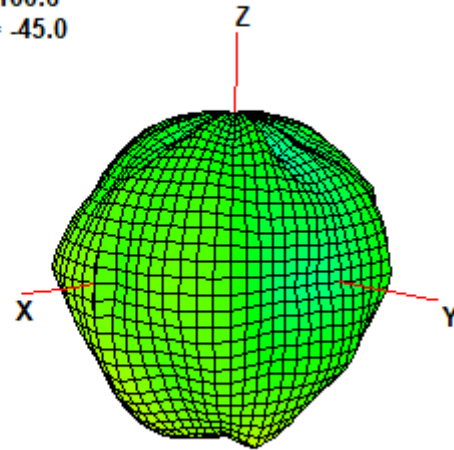

Center Frequency	2620MHz
Horizontal (dBi) peak	-0.47
Vertical (dBi) peak	0.07

2690MHz

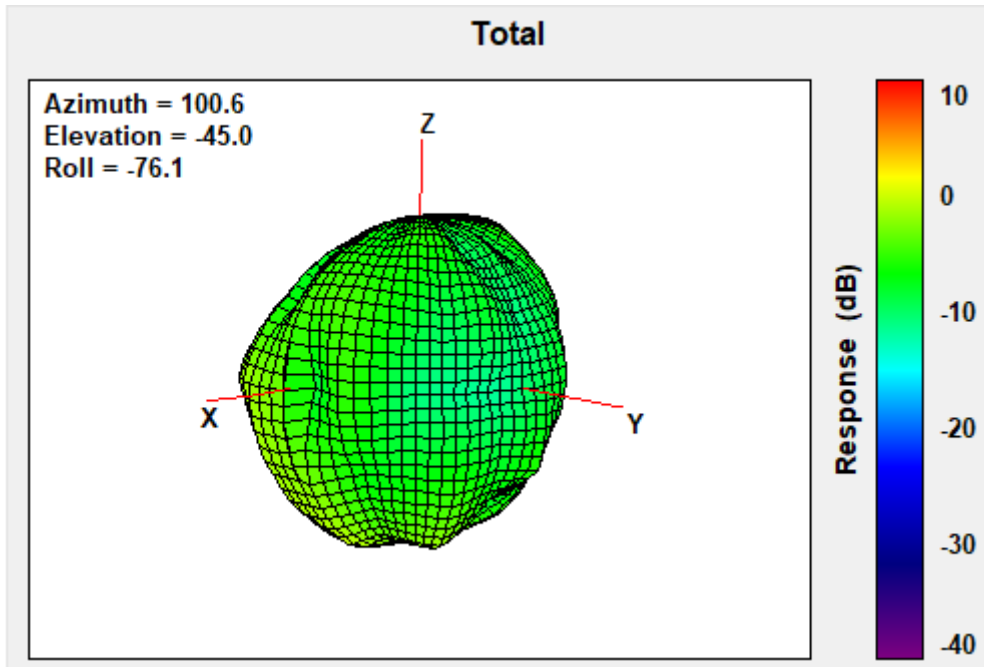

Center Frequency	2690MHz
Horizontal (dBi) peak	0.00
Vertical (dBi) peak	-2.79

3400MHz

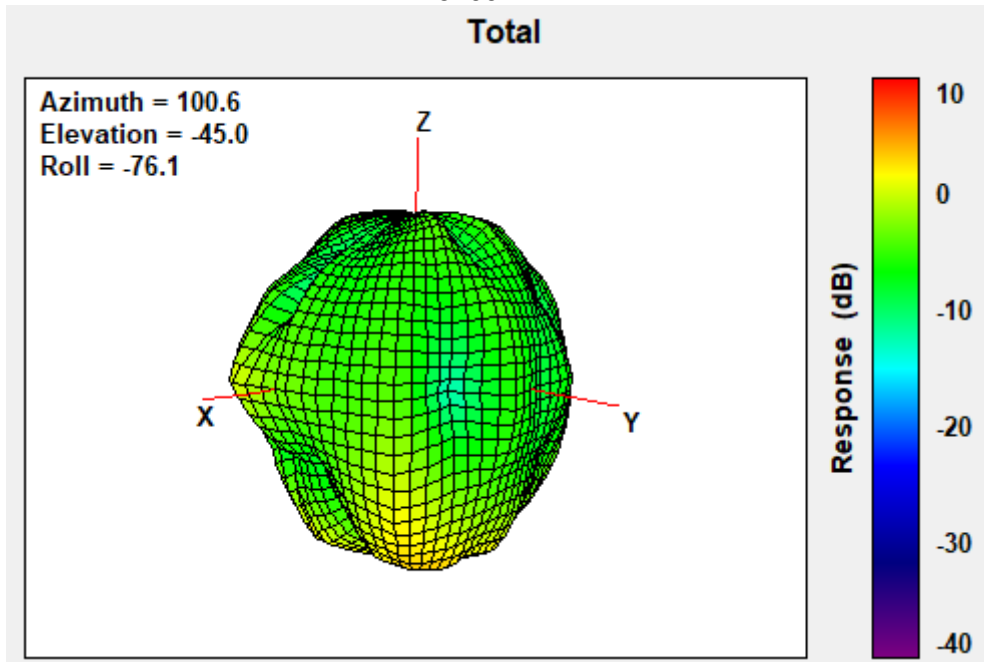

Center Frequency	3400MHz
Horizontal (dBi) peak	2.06
Vertical (dBi) peak	2.24

3500MHz

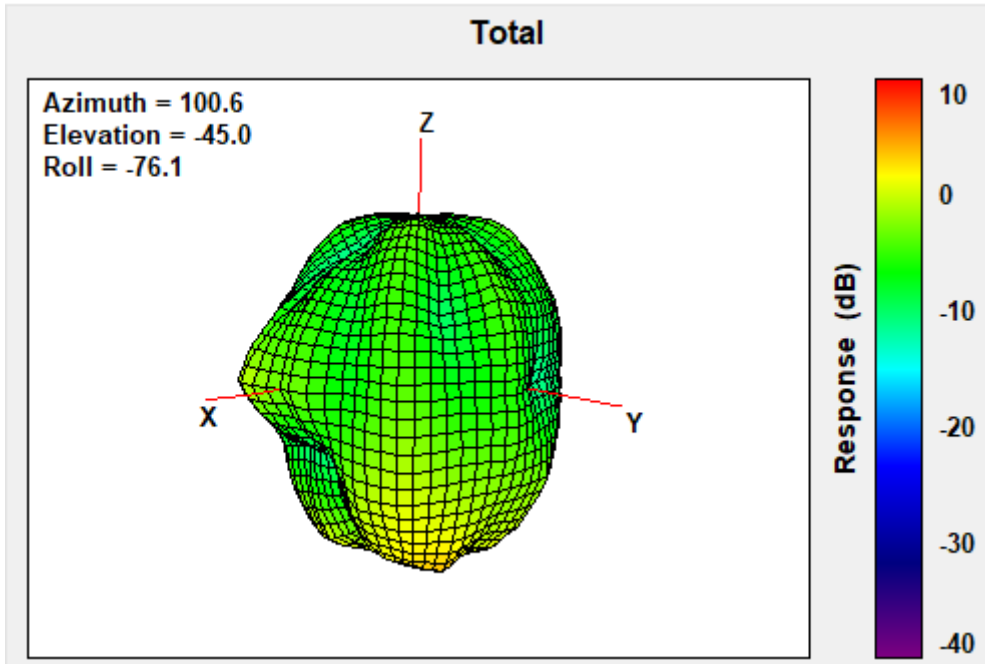

Center Frequency	3500MHz
Horizontal (dBi) peak	1.05
Vertical (dBi) peak	1.47

3600MHz

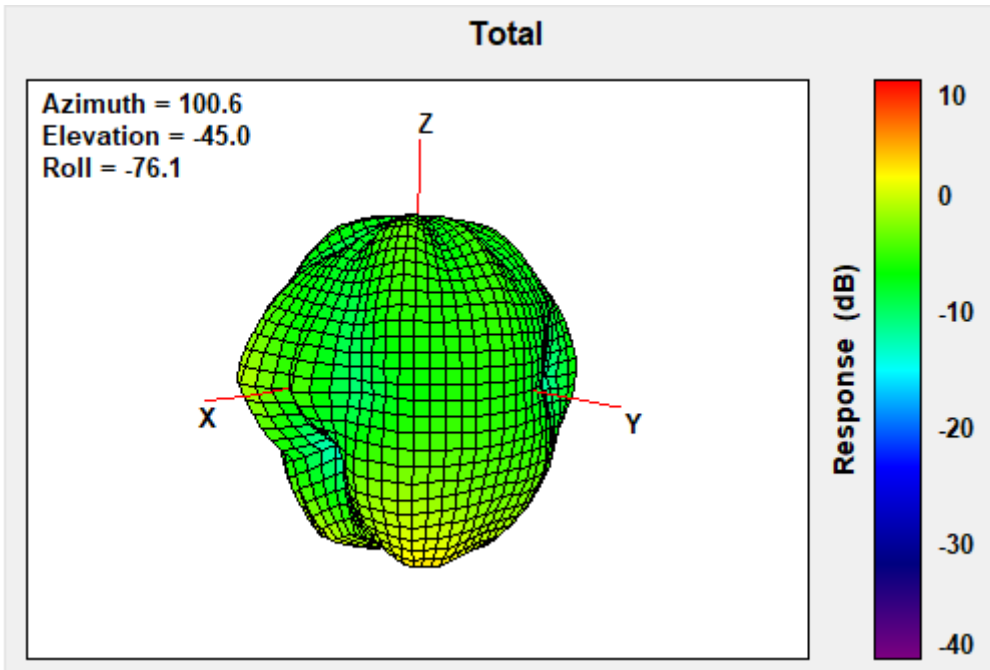

Center Frequency	3600MHz
Horizontal (dBi) peak	1.52
Vertical (dBi) peak	1.61

3700MHz

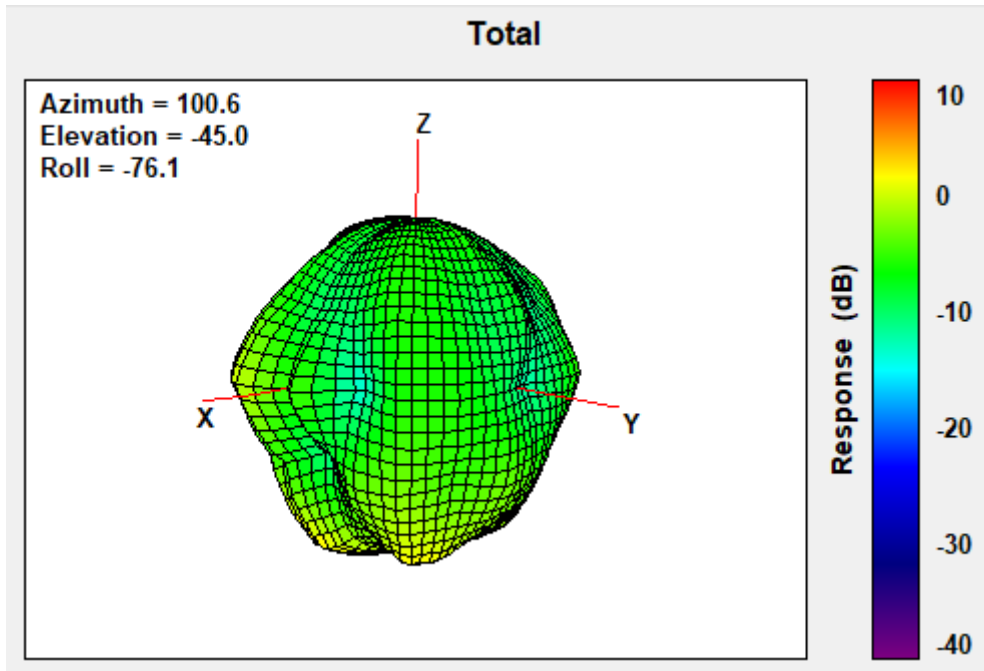

Center Frequency	3700MHz
Horizontal (dBi) peak	3.13
Vertical (dBi) peak	0.62

3800MHz

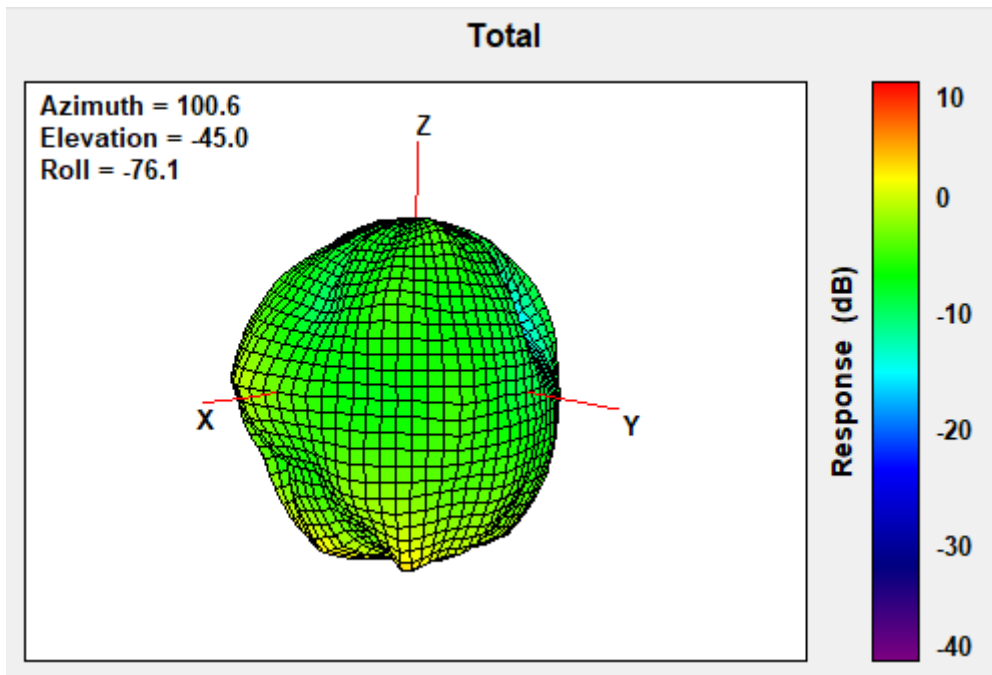

Center Frequency	3800MHz
Horizontal (dBi) peak	3.35
Vertical (dBi) peak	-0.18

4200MHz

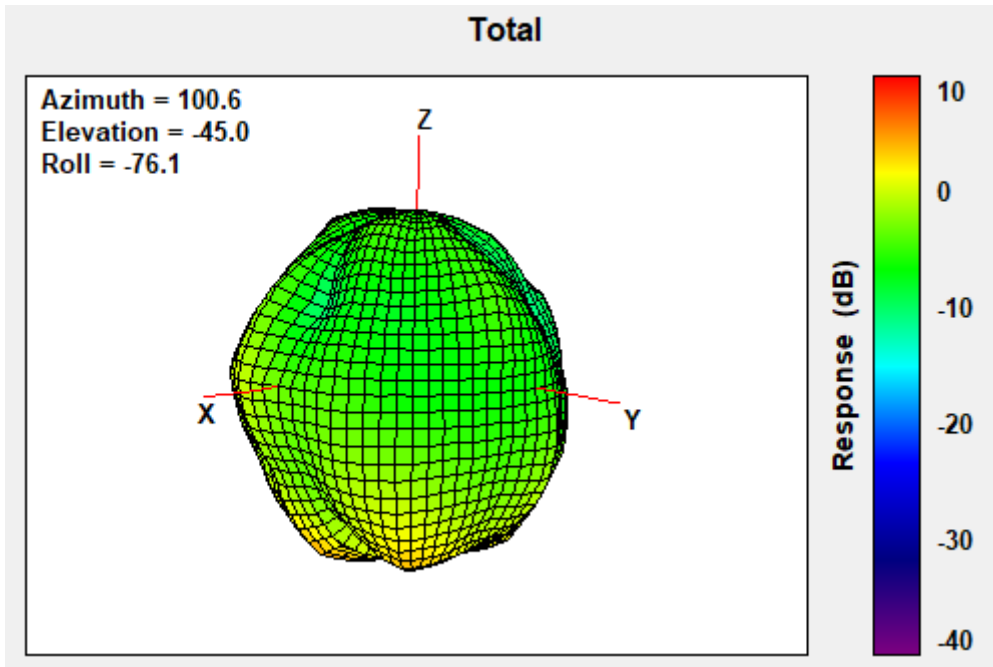

Center Frequency	4200MHz
Horizontal (dBi) peak	4.60
Vertical (dBi) peak	2.14

4400MHz

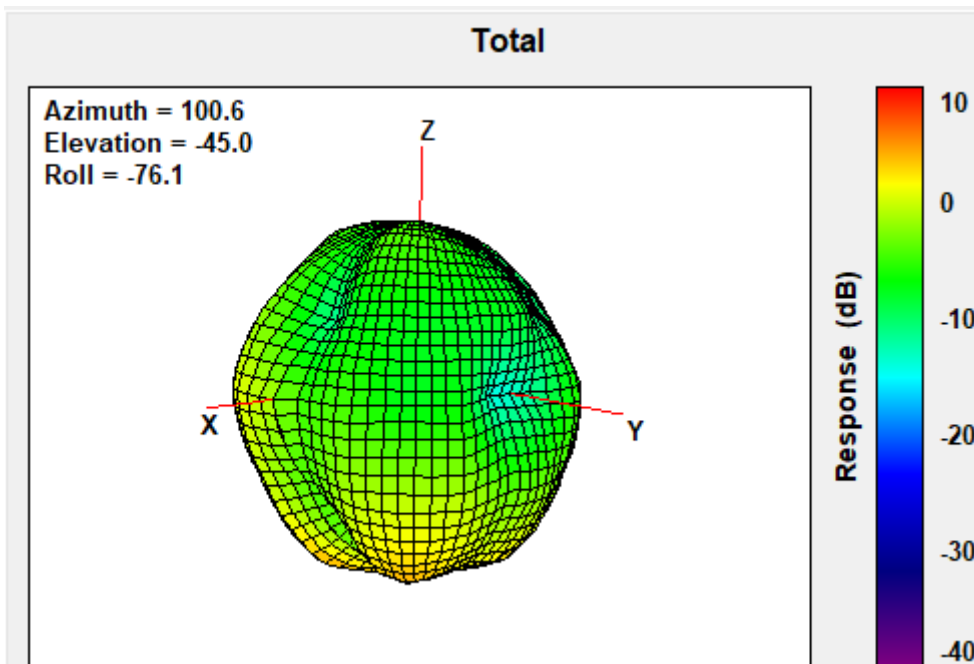

Center Frequency	4400MHz
Horizontal (dBi) peak	4.86
Vertical (dBi) peak	2.48

4700MHz

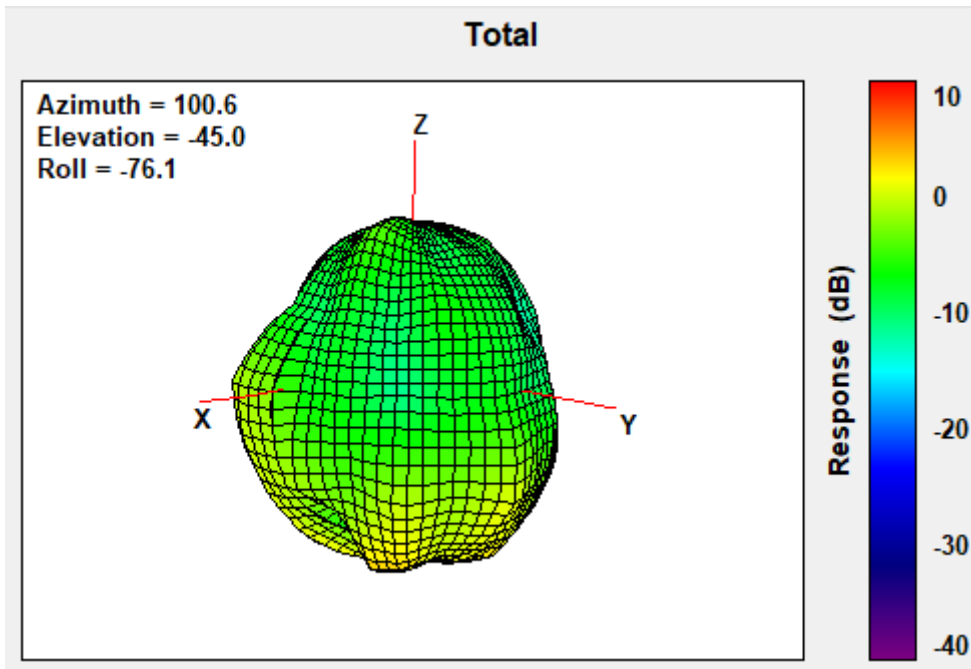

Center Frequency	4700MHz
Horizontal (dBi) peak	3.61
Vertical (dBi) peak	2.93

5000MHz

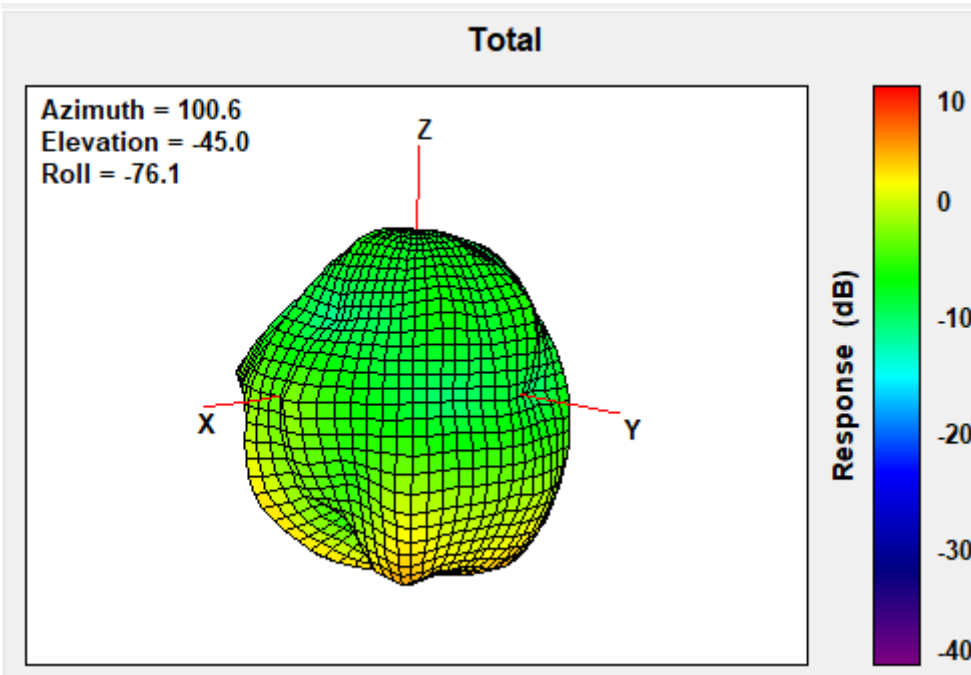

Center Frequency	5000MHz
Horizontal (dBi) peak	5.87
Vertical (dBi) peak	3.72

Section 4. Antenna Host Platform Location Information

Include a **dimensioned photo(s) or dimensioned drawing(s)** of Main and Aux antenna placements (measurements are not required for receive-only antenna).

Any antenna that transmits must show dimensions to bottom of laptop. Provide a description of the materials that are used for supporting or surrounding transmit antennas; for example, non-conductive plastics vs. conductive coated plastic or metallic materials.

Minimum Separation Distance			
Item	Antenna	Position	Distance (mm)
A	WWAN-Main	To top	204
B	WWAN-Main	To left	134
C	WWAN-Main	To right	114
D	WWAN-Main	To bottom	8
E	WWAN-Main	Main antenna length	63
F	Main-MIMO2	Main to MIMO2	8
G	MIMO2	To top	204
H	MIMO2	To left	70
I	MIMO2	To right	184
J	MIMO2	To bottom	8
K	MIMO2	MIMO2 antenna length	57
L	NB	Bumper thickness	3
X	MIMO2	To user	198
Y	WWAN-Main	To user	198
Z	NB	Keyboard depth	210

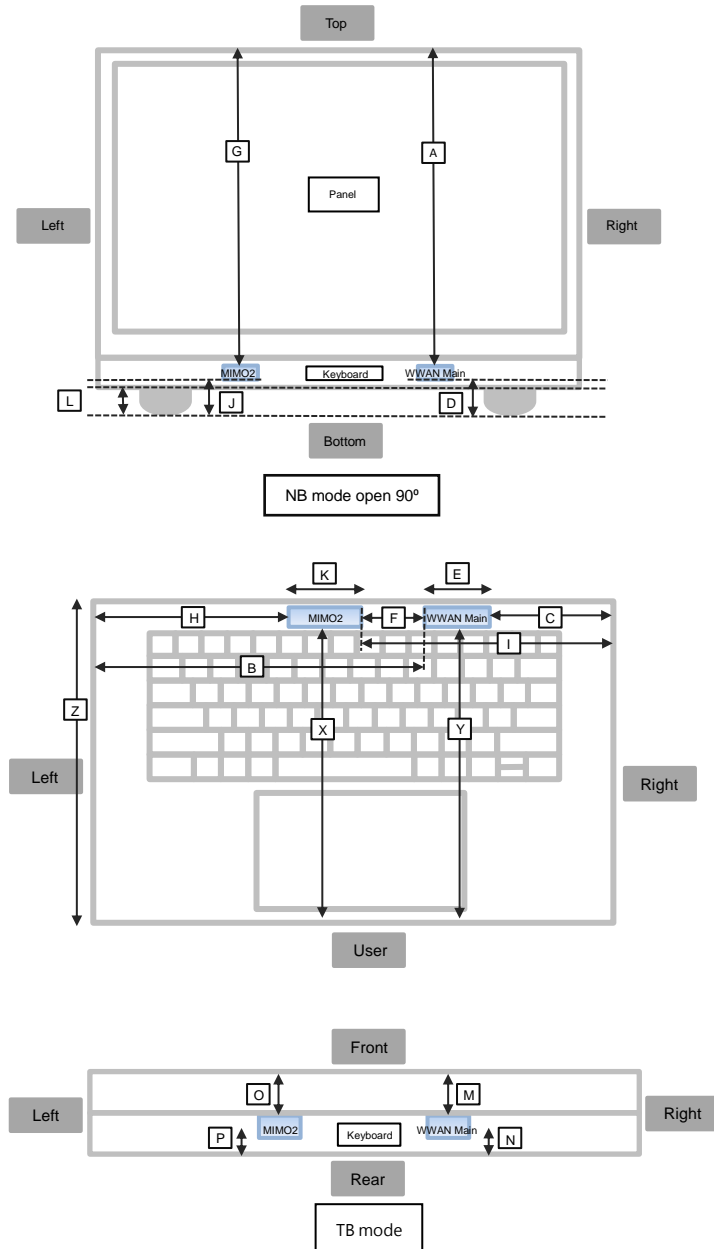

Minimum Separation Distance			
Item	Antenna	Position	Distance (mm)
M	WWAN-Main	To front	5
N	WWAN-Main	To rear	2.5
O	MIMO2	To front	5
P	MIMO2	To rear	2.5

Section 5. Antenna dimensional information for SAR evaluation

Include a **dimensioned photo(s) or dimensioned drawing(s)** showing the distance (mm) between the transmit antennas and the user. For notebook/laptop hosts show lapheld position (example below). For tablet hosts show all orientations including lapheld, primary & secondary portrait, primary & secondary landscape positions. Include a description of any proximity sensors or power throttling implementations that limit or exclude use of any host orientation.

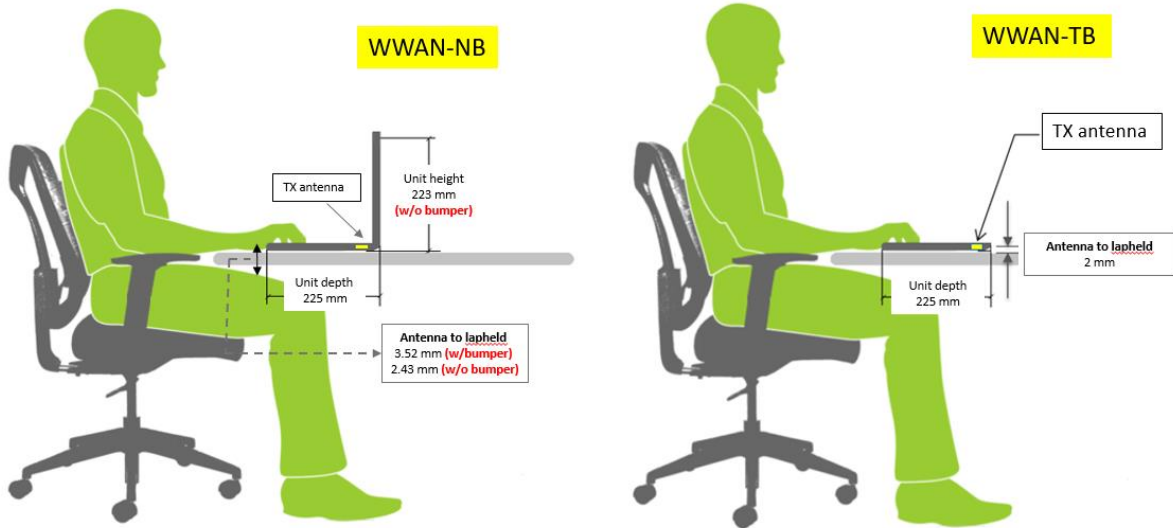

Minimum Separation Distance			
Item	Antenna	Position	Distance (mm)
A	WWAN-Main	to Bottom of Laptop (NOT include Bumper)	0

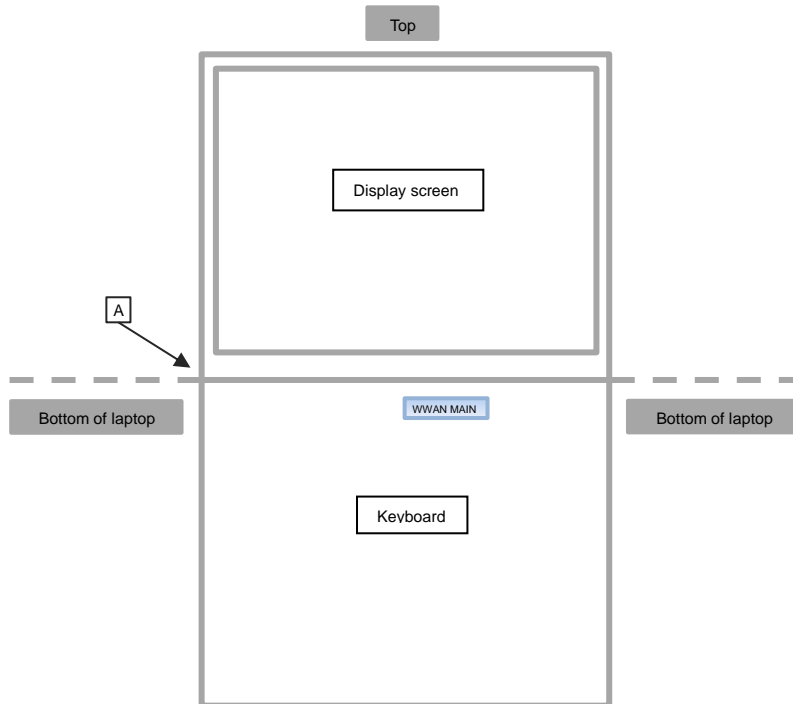

Section 6. Diagram Example of Co-Location Antenna Separation

Include a **dimensioned photo or dimensioned drawing** showing the distance (mm) between all WLAN transmit antennas and other co-located radiator transmit antenna such as Bluetooth, WWAN,..

(Note: Due to the evolving rules regarding co-location, each platform will need to be reviewed on a case by case basis)

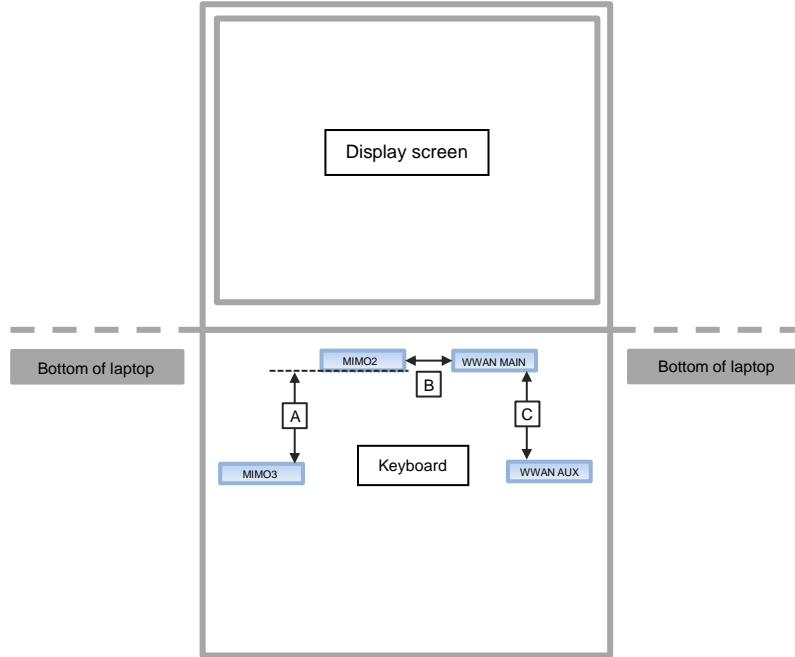

Minimum Separation Distance			
Item	Antenna	Position	Distance (mm)
A	MIMO3	MIMO2	190
B	MIMO2	WWAN-Main	8
C	WWAN-Main	WWAN-Aux	195