

## FCC 47 CFR PART 15 SUBPART C

Product Type : Thin Client Terminal  
Applicant : Dell Inc.  
Address : One Dell Way, Round Rock, Texas USA 78682  
Trade Name : Dell  
Model Number : CSxyyyy(x and y= 0-9, A-Z, a-z or blank), CSx  
Test Specification : FCC 47 CFR PART 15 SUBPART C: Oct., 2012  
ANSI C63.4-2009  
Receive Date : Jul. 09, 2013  
Test Period : Jul. 18 ~ 24, 2013  
Issue Date : Aug. 12, 2013

### Issue by

A Test Lab Techno Corp.  
No. 140-1, Changan Street, Bade City,  
Taoyuan County 334, Taiwan R.O.C.  
Tel : +886-3-2710188 / Fax : +886-3-2710190



Taiwan Accreditation Foundation accreditation number: 1330

**Note:** This report shall not be reproduced except in full, without the written approval of A Test Lab Techno Corp. This document may be altered or revised by A Test Lab Techno Corp. personnel only, and shall be noted in the revision section of the document. The client should not use it to claim product endorsement by TAF, or any government agencies. The test results in the report only apply to the tested sample.

**Revision History**

Rev.	Issue Date	Revisions	Revised By
00	Aug. 02, 2013	Initial Issue	
01	Aug. 12, 2013	Change Antenna type	Gili Huang

## Verification of Compliance

Issued Date: 08/12/2013

Product Type : Thin Client Terminal  
Applicant : Dell Inc.  
Address : One Dell Way, Round Rock, Texas USA 78682  
Trade Name : Dell  
Model Number : CSxyyyy(x and y= 0-9, A-Z, a-z or blank), CSx  
FCC ID : E2KCS1A13  
EUT Rated Voltage : DC 5.0V, 0.5A  
Test Voltage : 120 Vac / 60 Hz  
Applicable Standard : FCC 47 CFR PART 15 SUBPART C: Oct., 2012  
ANSI C63.4-2009  
Test Result : Complied  
Performing Lab. : A Test Lab Techno Corp.

No. 140-1, Changan Street, Bade City,  
Taoyuan County 334, Taiwan R.O.C.  
Tel : +886-3-2710188 / Fax : +886-3-2710190



Taiwan Accreditation Foundation accreditation number: 1330  
<http://www.atl-lab.com.tw/e-index.htm>

The above equipment was tested by A Test Lab Techno Corp. The test data, data evaluation, test procedures, and equipment configurations shown in this report were made in accordance with the procedures given in ANSI C63.4: 2009 and the energy emitted by the sample tested as described in this report is in compliance with the requirements of FCC Rules Part 15.207, 15.209, 15.247 .

The test results of this report relate only to the tested sample identified in this report.

Approved By



(Manager)

(Murphy Wang)

Reviewed By



(Testing Engineer)

(Fly Lu)

## TABLE OF CONTENTS

<b>1</b>	<b>General Information.....</b>	<b>6</b>
	1.1. Summary of Test Result.....	6
	1.2. Measurement Uncertainty.....	6
<b>2</b>	<b>EUT Description .....</b>	<b>7</b>
<b>3</b>	<b>Test Methodology .....</b>	<b>8</b>
	3.1. Mode of Operation .....	8
	3.2. EUT Exercise Software .....	8
	3.3. Configuration of Test System Details .....	9
	3.4. Test Site Environment .....	9
<b>4</b>	<b>Maximum Conducted Output Power Measurement .....</b>	<b>10</b>
	4.1. Limit.....	10
	4.2. Test Setup .....	10
	4.3. Test Instruments.....	10
	4.4. Test Procedure .....	10
	4.5. Test Result .....	11
<b>5</b>	<b>Conducted Emission Measurement.....</b>	<b>13</b>
	5.1. Limit.....	13
	5.2. Test Instruments.....	13
	5.3. Test Setup .....	13
	5.4. Test Procedure .....	14
	5.5. Test Result .....	14
<b>6</b>	<b>Radiated Interference Measurement.....</b>	<b>15</b>
	6.1. Limit.....	15
	6.2. Test Instruments.....	15
	6.3. Setup.....	16
	6.4. Test Procedure .....	17
	6.5. Test Result .....	18
<b>7</b>	<b>20dB RF Bandwidth and 99 % Occupied Bandwidth Measurement.....</b>	<b>22</b>
	7.1. Limit.....	22
	7.2. Test Setup .....	22
	7.3. Test Instruments.....	22
	7.4. Test Procedure .....	23
	7.5. Test Result .....	24
	7.6. Test Graphs.....	25

<b>8</b>	<b>Carrier Frequency Separation Measurement</b> .....	<b>27</b>
	8.1. Limit.....	27
	8.2. Test Setup .....	27
	8.3. Test Instruments.....	27
	8.4. Test Procedure .....	27
	8.5. Test Result .....	28
	8.6. Test Graphs.....	29
<b>9</b>	<b>Number of Hopping Measurement</b> .....	<b>30</b>
	9.1. Limit.....	30
	9.2. Test Setup .....	30
	9.3. Test Instruments.....	30
	9.4. Test Procedure .....	30
	9.5. Test Result .....	31
	9.6. Test Graphs.....	32
<b>10</b>	<b>Time of Occupancy (Dwell Time) Measurement</b> .....	<b>34</b>
	10.1. Limit.....	34
	10.2. Test Setup .....	34
	10.3. Test Instruments.....	34
	10.4. Test Procedure .....	34
	10.5. Test Result .....	35
	10.6. Test Graphs.....	37
<b>11</b>	<b>Out of Band Conducted Emissions Measurement</b> .....	<b>39</b>
	11.1. Limit.....	39
	11.2. Test Setup .....	39
	11.3. Test Instruments.....	39
	11.4. Test Procedure .....	39
	11.5. Test Graphs.....	40
<b>12</b>	<b>Band Edges Measurement</b> .....	<b>44</b>
	12.1. Limit.....	44
	12.2. Test Setup .....	44
	12.3. Test Instruments.....	44
	12.4. Test Procedure .....	45
	12.5. Test Result .....	46
<b>13</b>	<b>Antenna Measurement</b> .....	<b>56</b>
	13.1. Limit.....	56
	13.2. Antenna Connector Construction.....	56

---

## 1 General Information

### 1.1. Summary of Test Result

Standard		Item	Result	Remark
15.247	RSS-GEN			
15.207	7.2.2	AC Power Conducted Emission	N/A	This device's power is supplied by DC source.
Standard		Item	Result	Remark
15.247	RSS-210			
15.247(b)(1)	A8.4 (2)	Max. Output Power	PASS	-----
15.247(c)	A8.5	Transmitter Radiated Emissions	PASS	-----
15.247(a)(1)	A8.1 (1)	20dB RF Bandwidth	PASS	-----
15.247(a)(1)(iii)	A8.1 (2)	Carrier Frequency Separation	PASS	-----
15.247(a)(1)(iii)	A8.1 (4)	Number of Hopping	PASS	-----
15.247(a)(1)(iii)	A8.1 (4)	Time of Occupancy (Dwell Time)	PASS	-----
15.247(c)	A8.5	Out of Band Conducted Spurious Emission	PASS	-----
15.247(c)	A8.5	Band Edge Measurement	PASS	-----
15.247(c)	A8.5	Occupied Bandwidth Measurement	PASS	-----
15.203	-	Antenna Requirement	PASS	-----

The test results of this report relate only to the tested sample(s) identified in this report. Manufacturer or whom it may concern should recognize the pass or fail of the test result.

### 1.2. Measurement Uncertainty

Item	Frequency Range	Uncertainty (dB)	
AC Power Conducted Emission	9kHz ~ 30MHz	± 2.020	
Radiated Emissions	30MHz ~ 230MHz	Horizontal	± 3.960
		Vertical	± 3.570
	230MHz ~ 1000MHz	Horizontal	± 3.960
		Vertical	± 3.570
	1000MHz ~ 18000MHz	Horizontal	± 3.072
		Vertical	± 3.028
	18000MHz ~ 40000MHz	Horizontal	± 3.622
		Vertical	± 3.506

## 2 EUT Description

Product	Thin Client Terminal		
Trade Name	Dell		
Model Number	CSxyyyy(x and y= 0-9, A-Z, a-z or blank), CSx (Those model numbers differ from each other in selling regions.)		
Applicant	Dell Inc. One Dell Way, Round Rock, Texas USA 78682		
Manufacturer	Wyse Technology LLC 5455 Great America Parkway, Santa Clara, CA 95054		
FCC ID	E2KCS1A13		
Frequency Range	2402 ~ 2480 MHz		
Modulation Type	GFSK for 1Mbps		
	$\pi/4$ -DQPSK for 2Mbps		
	8DPSK for 3Mbps		
Antenna Type	Chip Antenna		
Antenna Gain	3.3 dBi		
RF Output Power (Conducted)	GFSK for 1Mbps	9.88 dBm /	0.010 W
	$\pi/4$ -DQPSK for 2Mbps	7.55 dBm /	0.006 W
	8DPSK for 3Mbps	7.56 dBm /	0.006 W

### 3 Test Methodology

#### 3.1. Mode of Operation

Decision of Test ATL has verified the construction and function in typical operation. All the test modes were carried out with the EUT in normal operation, which was shown in this test report and defined as:

Test Mode
Mode 1: Normal Operation Mode
Mode 2: GFSK Link Mode
Mode 3: $\pi/4$ -DQPSK Link Mode
Mode 4: 8DPSK Link Mode

By preliminary testing and verifying three axis (X, Y and Z) position of EUT transmitted status, it was found that "X axis" position was the worst, then the final test was executed the worst condition and test data were recorded in this report.

##### Description of Test Modes

Preliminary tests were performed in different modulation to find the worst case. The modulation has shown the worst-case in section 6.5. Investigation has been done on all the possible configurations for searching the worst cases.

##### Tested System Details

The types for all equipments, plus descriptions of all cables used in the tested system (including inserted cards) are:

	Product	Manufacturer	Model Number	Serial Number	Power Cord
1.	Bluetooth Tester	R & S	CBT	100350	NA

#### 3.2. EUT Exercise Software

1	Setup the EUT and Bluetooth Tester (CBT) as shown on 3.3.
2	Turn on the power of all equipment.
3	EUT run test program.
4	Open Bluetooth function link to CBT.



### 3.3. Configuration of Test System Details

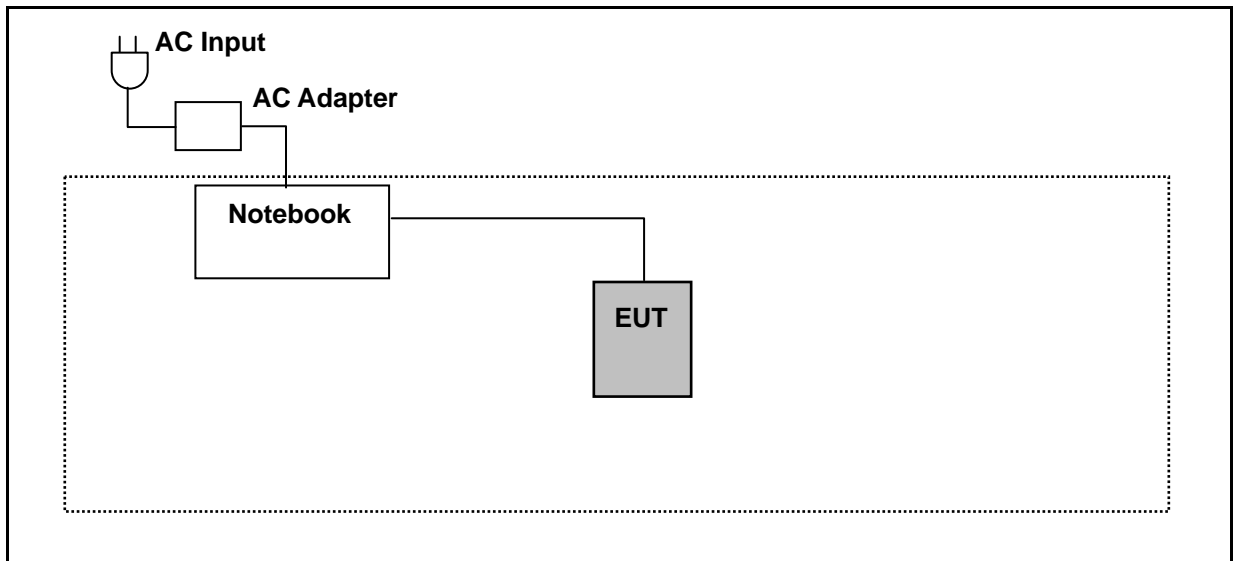

### 3.4. Test Site Environment

Items	Required (IEC 68-1)	Actual
Temperature (°C)	15-35	26
Humidity (%RH)	25-75	60
Barometric pressure (mbar)	860-1060	950

## 4 Maximum Conducted Output Power Measurement

### 4.1. Limit

For frequency hopping systems operating in the 2400–2483.5 MHz band employing at least 75 non-overlapping hopping channels < 1 watt.

### 4.2. Test Setup

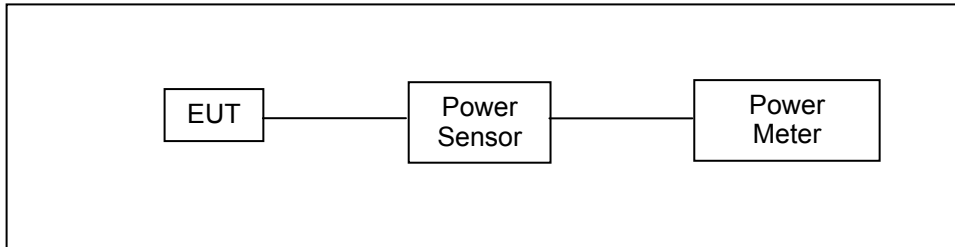

### 4.3. Test Instruments

Equipment	Manufacturer	Model Number	Serial Number	Cal. Date	Remark
Single Channel PK Power Sensor	Agilent	N1911A	MY45101619	12/19/2012	(1)
Wideband Power Meter	Agilent	N1921A	MY45241957	12/19/2012	(1)
Test Site	ATL	TE02	TE02	N.C.R.	-----

Remark: (1) Calibration period 1 year. (2) Calibration period 2 years.

NOTE: N.C.R. = No Calibration Request.

### 4.4. Test Procedure

Testing must be done according to this procedure, FCC Public Notice DA 00-705 - Filing and Measurement Guidelines for Frequency Hopping Spread Spectrum Systems. This is the only method recognized by the FCC. The tests below are run with the EUT's transmitter set at high power in TX mode. The EUT is needed to force selection of output power level and channel number. While testing, EUT was set to transmit continuously. Remove the Subjective device's antenna and connect the RF output port to power sensor. The maximum peak output power shall not exceed 1 watt.

Use a direct connection between the antenna port of transmitter and the power sensor, for prevent the power sensor input attenuation 40-50 dB. Set the RBW Bandwidth of the emission or use a channel power meter mode. For antennas with gains of 6 dBi or less, maximum allowed transmitter output is 1 watt (+30 dBm). For antennas with gains greater than 6 dBi, transmitter output level must be decreased by an amount equal to (GAIN - 6)/3 dBm. The antenna port of the EUT was connected to the input of a power sensor. Power was read directly and cable loss correction was added to the reading to obtain power at the EUT antenna terminals.

**4.5. Test Result**

Model Number	CS1A13					
Test Item	Maximum Conducted Output Power					
Test Mode	Mode 2: GFSK Link Mode					
Date of Test	07/18/2013			Test Site	TE02	
Frequency (MHz)	Packet Type	Average Power		Peak Power		Limit (W)
		(dBm)	(W)	(dBm)	(W)	
2402	DH1	10.12	0.010	9.82	0.010	< 1
	DH3	10.15	0.010	9.85	0.010	< 1
	DH5	10.15	0.010	9.85	0.010	< 1
2441	DH1	10.15	0.010	9.84	0.010	< 1
	DH3	10.17	0.010	9.86	0.010	< 1
	DH5	10.19	0.010	<b>9.88</b>	<b>0.010</b>	< 1
2480	DH1	9.41	0.009	9.09	0.008	< 1
	DH3	9.42	0.009	9.10	0.008	< 1
	DH5	9.44	0.009	9.12	0.008	< 1

Model Number	CS1A13					
Test Item	Maximum Conducted Output Power					
Test Mode	Mode 3: $\pi/4$ -DQPSK Mode					
Date of Test	07/18/2013			Test Site	TE02	
Frequency (MHz)	Packet Type	Average Power		Peak Power		Limit (W)
		(dBm)	(W)	(dBm)	(W)	
2402	DH1	9.18	0.008	6.95	0.005	< 1
	DH3	9.20	0.008	6.97	0.005	< 1
	DH5	9.21	0.008	6.97	0.005	< 1
2441	DH1	9.62	0.009	7.53	0.006	< 1
	DH3	9.64	0.009	7.53	0.006	< 1
	DH5	9.66	0.009	<b>7.55</b>	<b>0.006</b>	< 1
2480	DH1	8.97	0.008	6.89	0.005	< 1
	DH3	8.99	0.008	6.90	0.005	< 1
	DH5	9.00	0.008	6.91	0.005	< 1

Model Number	CS1A13					
Test Item	Maximum Conducted Output Power					
Test Mode	Mode 4: 8DPSK Link Mode					
Date of Test	07/18/2013			Test Site	TE02	
Frequency (MHz)	Packet Type	Average Power		Peak Power		Limit (W)
		(dBm)	(W)	(dBm)	(W)	
2402	DH1	6.96	0.005	6.96	0.005	< 1
	DH3	6.98	0.005	6.98	0.005	< 1
	DH5	6.99	0.005	6.99	0.005	< 1
2441	DH1	7.54	0.006	7.54	0.006	< 1
	DH3	7.54	0.006	7.54	0.006	< 1
	DH5	7.56	0.006	<b>7.56</b>	<b>0.006</b>	< 1
2480	DH1	6.91	0.005	6.91	0.005	< 1
	DH3	6.92	0.005	6.92	0.005	< 1
	DH5	6.92	0.005	6.92	0.005	< 1

## 5 Conducted Emission Measurement

### 5.1. Limit

Frequency (MHz)	Quasi-peak	Average
0.15 - 0.5	66 to 56	56 to 46
0.50 - 5.0	56	46
5.0 - 30.0	60	50

### 5.2. Test Instruments

Describe	Manufacturer	Model Number	Serial Number	Cal. Date	Remark
Test Receiver	R&S	ESCI	100367	06/06/2013	(1)
LISN	R&S	ENV216	101040	03/04/2013	(1)
LISN	R&S	ENV216	101041	03/04/2013	(1)
Test Site	ATL	TE05	TE05	N.C.R.	-----

Remark: (1) Calibration period 1 year. (2) Calibration period 2 years.

NOTE: N.C.R. = No Calibration Request.

### 5.3. Test Setup

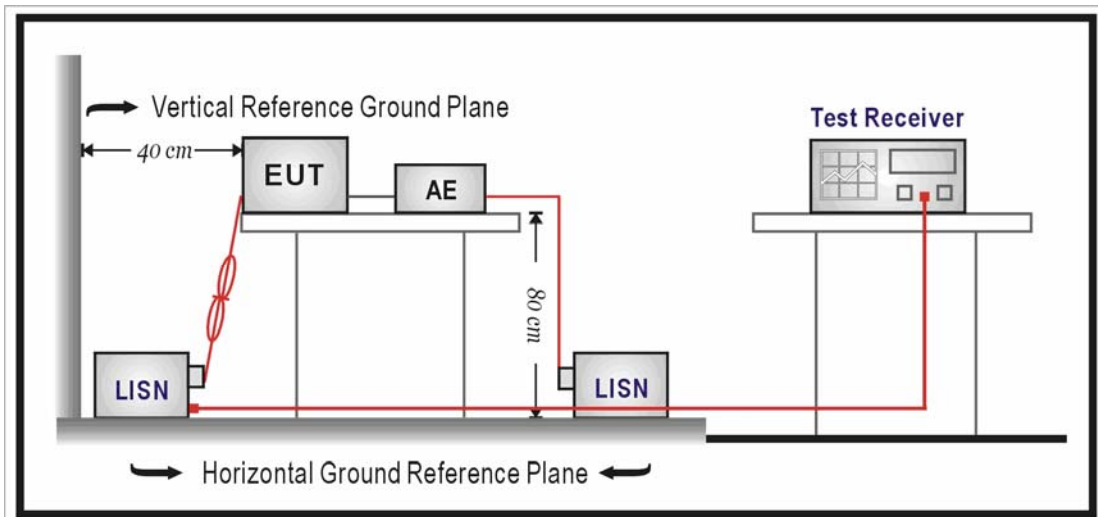

#### **5.4. Test Procedure**

The power line conducted emission measurements were performed in a shielded enclosure. The EUT was assembled on a wooden table which is 80 centimeters high, was placed 40 centimeters from the back wall and at least 1 meter from the sidewall.

Power was fed to the EUT from the public utility power grid through a line filter and EMCO Model 3162/2 SH Line Impedance Stabilization Networks (LISN). The LISN housing, measuring instrumentation case, ground plane, etc., were electrically bonded together at the same RF potential. The Spectrum analyzer was connected to the AC line through an isolation transformer. The 50-ohm output of the LISN was connected to the spectrum analyzer directly. Conducted emission levels were in the CISPR quasi-peak detection mode. The analyzer's 6 dB bandwidth was set to 9 KHz. No post-detector video filter was used.

The spectrum was scanned from 150 KHz to 30 MHz. The physical arrangement of the test system and associated cabling was varied (within the scope of arrangements likely to be encountered in actual use) to determine the effect on the unit's emanations in amplitude and frequency. All spurious emission frequencies were observed. The highest emission amplitudes relative to the appropriate limit were measured and have been recorded in paragraph 4.1.

#### **5.5. Test Result**

Not applicable, this device's power is supplied by DC source.

## 6 Radiated Interference Measurement

### 6.1. Limit

According to §15.209(a), except as provided elsewhere in this subpart, the emissions from an intentional radiator shall not exceed the field strength levels specified in the following table:

Frequency (MHz)	Field Strength ( $\mu\text{V}/\text{m}$ at meter)	Measurement Distance (meters)
0.009 – 0.490	2400 / F (kHz)	300
0.490 – 1.705	24000 / F (kHz)	30
1.705 – 30.0	30	30
30 - 88	100**	3
88-216	150**	3
216-960	200**	3
Above 960	500	3

\*\* Except as provided in paragraph (g), fundamental emissions from intentional radiators operating under this Section shall not be located in the frequency bands 54-72 MHz, 76-88 MHz, 174-216 MHz or 470-806 MHz. However, operation within these frequency bands is permitted under other sections of this Part, e.g., Sections 15.231 and 15.241.

### 6.2. Test Instruments

3 Meter Chamber					
Equipment	Manufacturer	Model Number	Serial Number	Cal. Date	Remark
RF Pre-selector	Agilent	N9039A	MY46520256	01/21/2013	(1)
Spectrum Analyzer	Agilent	E4446A	MY46180578	01/21/2013	(1)
Pre Amplifier	Agilent	8449B	3008A02237	02/21/2013	(1)
Pre Amplifier	Agilent	8447D	2944A10961	02/21/2013	(1)
Broadband Antenna (30MHz~1GHz)	SCHWARZBECK MESS-ELEKTRONIK	VULB9163	9163-270	07/16/2013	(1)
Horn Antenna (1~18GHz)	SCHWARZBECK MESS-ELEKTRONIK	BBHA9120D	9120D-550	06/10/2013	(1)
Horn Antenna (18~40GHz)	SCHWARZBECK MESS-ELEKTRONIK	BBHA9170	9170-320	06/13/2013	(1)
Loop Antenna	COM-POWER CORPORATION	AL-130	121014	08/14/2012	(3)
Test Site	ATL	TE01	888001	08/28/2012	(1)

### 6.3. Setup

Below 1GHz

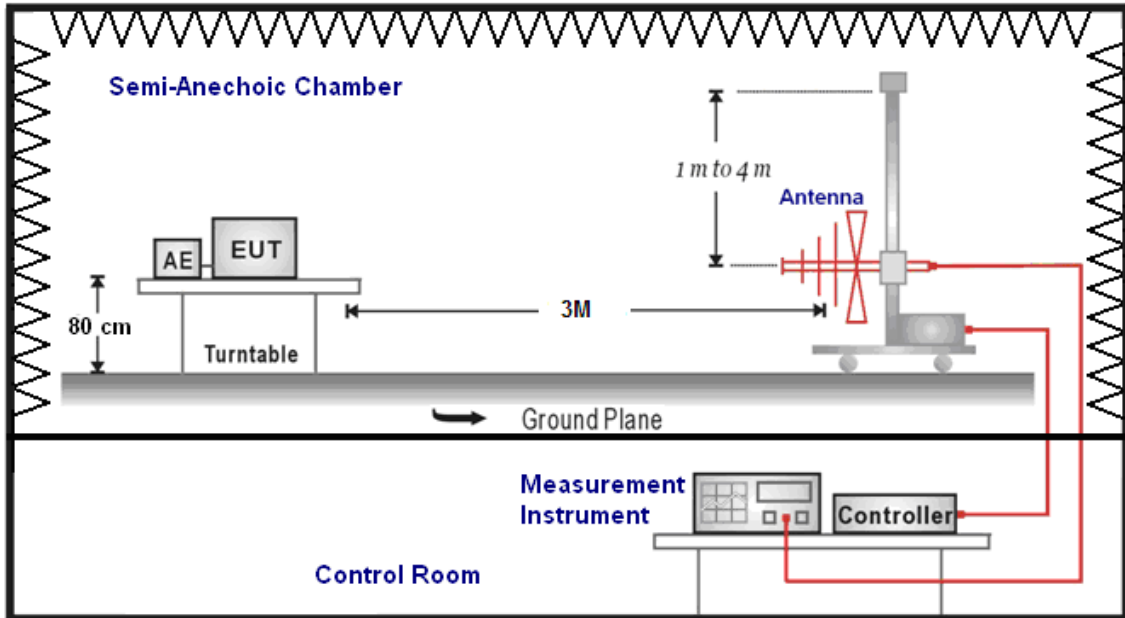

Above 1GHz

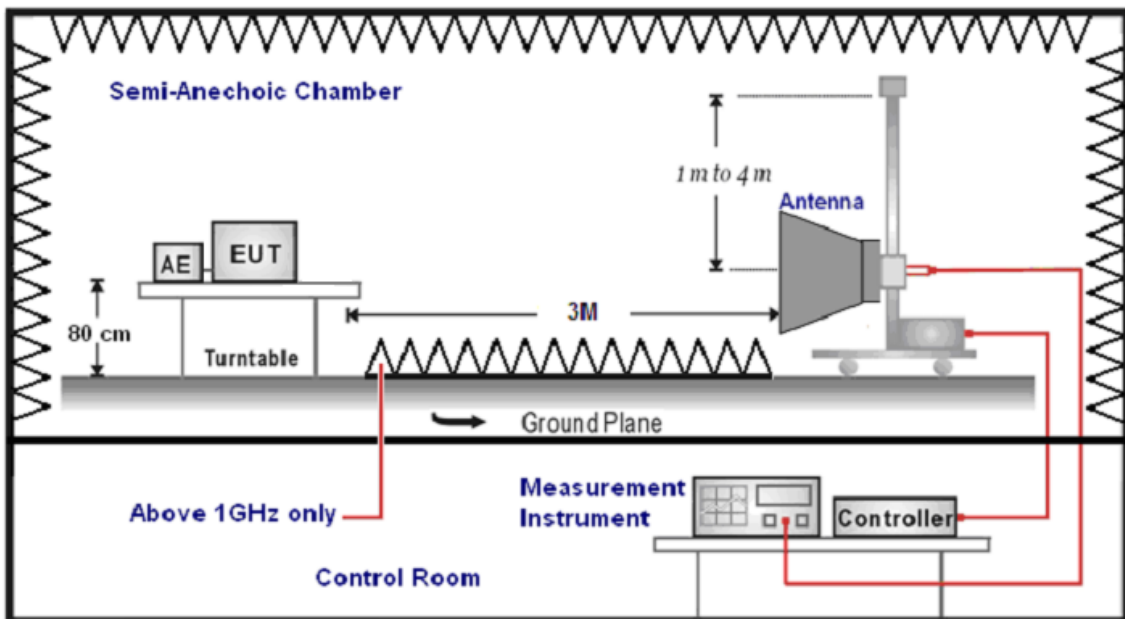



## 6.4. Test Procedure

Final radiation measurements were made on a three-meter, Semi Anechoic Chamber. The EUT system was placed on a nonconductive turntable which is 0.8 meters height, top surface 1.0 x 1.5 meter. The spectrum was examined from 250 MHz to 2.5 GHz in order to cover the whole spectrum below 10th harmonic which could generate from the EUT. During the test, EUT was set to transmit continuously & Measurements spectrum range from 9 kHz to 26.5 GHz is investigated.

For measurements below 1 GHz the resolution bandwidth is set to 100 kHz for peak detection measurements or 120 kHz for quasi-peak detection measurements. Peak detection is used unless otherwise noted as quasi-peak.

For measurements above 1 GHz the resolution bandwidth is set to 1 MHz, and then the video bandwidth is set to 1 MHz for peak measurements and 10 Hz for average measurements.

A nonconductive material surrounded the EUT to supporting the EUT for standing on three orthogonal planes. At each condition, the EUT was rotated 360 degrees, and the antenna was raised and lowered from one to four meters to find the maximum emission levels. Measurements were taken using both horizontal and vertical antenna polarization.

SCHWARZBECK MESS-ELEKTRONIK Biconilog Antenna (mode VULB9163) at 3 Meter and the SCHWARZBECK Double Ridged Guide Antenna (model BBHA9120D&9170) was used in frequencies 1 – 26.5 GHz at a distance of 1 meter. All test results were extrapolated to equivalent signal at 3 meters utilizing an inverse linear distance extrapolation Factor (20dB/decade).

For testing above 1GHz, the emission level of the EUT in peak mode was 20dB lower than average limit (that means the emission level in peak mode also complies with the limit in average mode), then testing will be stopped and peak values of EUT will be reported, otherwise, the emissions will be measured in average mode again and reported.

Appropriate preamplifiers were used for improving sensitivity and precautions were taken to avoid overloading or desensitizing the spectrum analyzer. No post – detector video filters were used in the test.

The spectrum analyzer's 6 dB bandwidth was set to 1 MHz, and the analyzer was operated in the peak detection mode, for frequencies both below and up 1 GHz. The average levels were obtained by subtracting the duty cycle correction factor from the peak readings.

The following procedures were used to convert the emission levels measured in decibels referenced to 1 microvolt (dBuV) into field intensity in micro volts per meter (uV/m).

The actual field intensity in decibels referenced to 1 microvolt in to field intensity in micro volts per meter (dBuV/m).

The actual field intensity in decibels referenced to 1 microvolt per meter (dBuV/m) is determined by algebraically adding the measured reading in dBuV, the antenna factor (dB), and cable loss (dB) and Subtracting the gain of preamplifier (dB) is auto calculate in spectrum analyzer.

$$(1) \text{ Amplitude (dBuV/m) = FI (dBuV) + AF (dBuV) + CL (dBuV) - Gain (dB)}$$

FI= Reading of the field intensity.

AF= Antenna factor.

CL= Cable loss.

P.S Amplitude is auto calculate in spectrum analyzer.

$$(2) \text{ Actual Amplitude (dBuV/m) = Amplitude (dBuV) - Dis(dB)}$$

The FCC specified emission limits were calculated according the EUT operating frequency and by following linear interpolation equations:

(a) For fundamental frequency : Transmitter Output < +30dBm

(b) For spurious frequency : Spurious emission limits = fundamental emission limit /10

Data of measurement within this frequency range without mark in the table above means the reading of emissions are attenuated more than 20dB below the permissible limits or the field strength is too small to be measured.

## 6.5. Test Result

### Below 1GHz

Standard:	FCC Part 15C	Test Distance:	3m
Test item:	Radiated Emission	Power:	AC 120V/60Hz
Model Number:	CS1A13	Temp.(°C)/Hum.(%RH):	26(°C)/60%RH
Mode:	Mode 1	Date:	07/18/2013
		Test By:	Fly Lu

Frequency (MHz)	Reading (dBuV)	Correct Factor (dB/m)	Result (dBuV/m)	Limit (dBuV/m)	Margin (dB)	Remark	Ant.Polar. H / V
199.0000	47.60	-14.39	33.21	43.50	-10.29	QP	H
272.0000	45.06	-11.02	34.04	46.00	-11.96	QP	H
399.5000	39.52	-8.21	31.31	46.00	-14.69	QP	H
644.5000	33.91	-3.14	30.77	46.00	-15.23	QP	H
742.5000	42.10	-1.34	40.76	46.00	-5.24	QP	H
960.0000	29.88	2.86	32.74	46.00	-13.26	QP	H
199.5000	43.73	-14.38	29.35	43.50	-14.15	QP	V
399.5000	48.68	-8.21	40.47	46.00	-5.53	QP	V
530.0000	42.96	-5.66	37.30	46.00	-8.70	QP	V
742.5000	37.47	-1.34	36.13	46.00	-9.87	QP	V
796.5000	32.67	-0.22	32.45	46.00	-13.55	QP	V
933.5000	30.17	2.49	32.66	46.00	-13.34	QP	V

Note: No emission found between lowest internal used/generated frequencies to 30MHz (9 kHz~30MHz).

**Above 1GHz**

Standard:	FCC Part 15C	Test Distance:	3m
Test item:	Radiated Emission	Power:	AC 120V/60Hz
Model Number:	CS1A13	Temp.(°C)/Hum.(%RH):	26(°C)/60%RH
Mode:	Mode 2	Date:	07/18/2013
Frequency:	2402 MHz	Test By:	Fly Lu

Frequency (MHz)	Reading (dBuV)	Correct Factor (dB/m)	Result (dBuV/m)	Limit (dBuV/m)	Margin (dB)	Remark	Ant.Polar. H / V
2911.000	35.88	5.68	41.56	74.00	-32.44	peak	H
4577.000	34.08	11.07	45.15	74.00	-28.85	peak	H
6362.000	32.85	16.99	49.84	74.00	-24.16	peak	H
2883.000	37.79	5.61	43.40	74.00	-30.60	peak	V
4549.000	35.01	11.01	46.02	74.00	-27.98	peak	V
6390.000	33.03	17.08	50.11	74.00	-23.89	peak	V

Standard:	FCC Part 15C	Test Distance:	3m
Test item:	Radiated Emission	Power:	AC 120V/60Hz
Model Number:	CS1A13	Temp.(°C)/Hum.(%RH):	26(°C)/60%RH
Mode:	Mode 2	Date:	07/18/2013
Frequency:	2441 MHz	Test By:	Fly Lu

Frequency (MHz)	Reading (dBuV)	Correct Factor (dB/m)	Result (dBuV/m)	Limit (dBuV/m)	Margin (dB)	Remark	Ant.Polar. H / V
2925.000	36.25	5.72	41.97	74.00	-32.03	peak	H
4535.000	34.59	10.97	45.56	74.00	-28.44	peak	H
6390.000	33.89	17.08	50.97	74.00	-23.03	peak	H
2918.000	37.00	5.70	42.70	74.00	-31.30	peak	V
4542.000	36.21	10.99	47.20	74.00	-26.80	peak	V
6390.000	34.09	17.08	51.17	74.00	-22.83	peak	V

Standard:	FCC Part 15C	Test Distance:	3m
Test item:	Radiated Emission	Power:	AC 120V/60Hz
Model Number:	CS1A13	Temp.(°C)/Hum.(%RH):	26(°C)/60%RH
Mode:	Mode 2	Date:	07/18/2013
Frequency:	2480 MHz	Test By:	Fly Lu

Frequency (MHz)	Reading (dBuV)	Correct Factor (dB/m)	Result (dBuV/m)	Limit (dBuV/m)	Margin (dB)	Remark	Ant.Polar. H / V
2897.000	35.73	5.64	41.37	74.00	-32.63	peak	H
4542.000	35.10	10.99	46.09	74.00	-27.91	peak	H
6467.000	33.61	17.31	50.92	74.00	-23.08	peak	H
2918.000	36.85	5.70	42.55	74.00	-31.45	peak	V
4535.000	34.34	10.97	45.31	74.00	-28.69	peak	V
6397.000	33.30	17.10	50.40	74.00	-23.60	peak	V

Standard:	FCC Part 15C	Test Distance:	3m
Test item:	Radiated Emission	Power:	AC 120V/60Hz
Model Number:	CS1A13	Temp.(°C)/Hum.(%RH):	26(°C)/60%RH
Mode:	Mode 4	Date:	07/18/2013
Frequency:	2402 MHz	Test By:	Fly Lu

Frequency (MHz)	Reading (dBuV)	Correct Factor (dB/m)	Result (dBuV/m)	Limit (dBuV/m)	Margin (dB)	Remark	Ant.Polar. H / V
2897.000	36.07	5.64	41.71	74.00	-32.29	peak	H
4542.000	35.04	10.99	46.03	74.00	-27.97	peak	H
6369.000	33.28	17.00	50.28	74.00	-23.72	peak	H
2946.000	36.86	5.76	42.62	74.00	-31.38	peak	V
4570.000	35.10	11.06	46.16	74.00	-27.84	peak	V
6215.000	33.47	16.54	50.01	74.00	-23.99	peak	V

Standard:	FCC Part 15C	Test Distance:	3m
Test item:	Radiated Emission	Power:	AC 120V/60Hz
Model Number:	CS1A13	Temp.(°C)/Hum.(%RH):	26(°C)/60%RH
Mode:	Mode 4	Date:	07/18/2013
Frequency:	2441 MHz	Test By:	Fly Lu

Frequency (MHz)	Reading (dBuV)	Correct Factor (dB/m)	Result (dBuV/m)	Limit (dBuV/m)	Margin (dB)	Remark	Ant.Polar. H / V
2897.000	36.34	5.64	41.98	74.00	-32.02	peak	H
4570.000	35.73	11.06	46.79	74.00	-27.21	peak	H
6355.000	33.79	16.97	50.76	74.00	-23.24	peak	H
2974.000	36.11	5.84	41.95	74.00	-32.05	peak	V
4542.000	34.84	10.99	45.83	74.00	-28.17	peak	V
6397.000	33.44	17.10	50.54	74.00	-23.46	peak	V

Standard:	FCC Part 15C	Test Distance:	3m
Test item:	Radiated Emission	Power:	AC 120V/60Hz
Model Number:	CS1A13	Temp.(°C)/Hum.(%RH):	26(°C)/60%RH
Mode:	Mode 4	Date:	07/18/2013
Frequency:	2480 MHz	Test By:	Fly Lu

Frequency (MHz)	Reading (dBuV)	Correct Factor (dB/m)	Result (dBuV/m)	Limit (dBuV/m)	Margin (dB)	Remark	Ant.Polar. H / V
2939.000	37.33	5.75	43.08	74.00	-30.92	peak	H
4549.000	34.99	11.01	46.00	74.00	-28.00	peak	H
6425.000	33.14	17.18	50.32	74.00	-23.68	peak	H
2918.000	35.89	5.70	41.59	74.00	-32.41	peak	V
4521.000	35.03	10.93	45.96	74.00	-28.04	peak	V
6341.000	32.06	16.92	48.98	74.00	-25.02	peak	V

## 7 20dB RF Bandwidth and 99 % Occupied Bandwidth Measurement

### 7.1. Limit

N/A

### 7.2. Test Setup

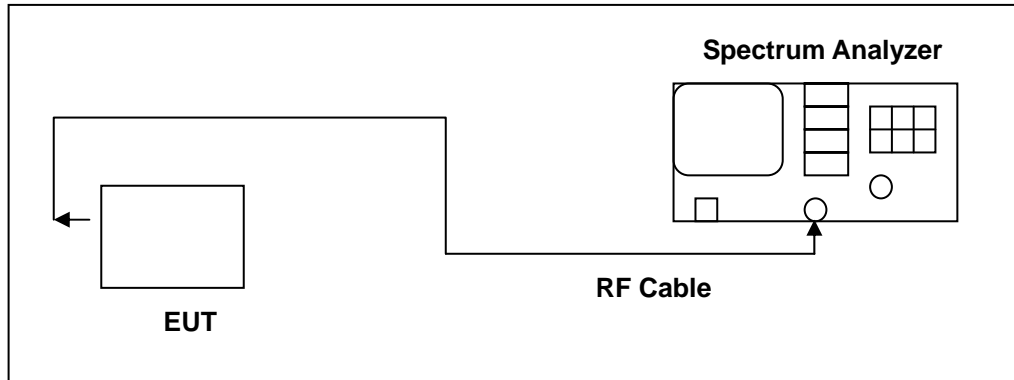

### 7.3. Test Instruments

Equipment	Manufacturer	Model Number	Serial Number	Cal. Date	Remark
Spectrum Analyzer	Agilent	E4445A	MY45300744	12/19/2012	(1)
Test Site	ATL	TE02	TE02	N.C.R.	-----

Remark: (1) Calibration period 1 year. (2) Calibration period 2 years.

NOTE: N.C.R. = No Calibration Request.

## 7.4. Test Procedure

### 20dB RF Bandwidth

Testing must be done according to this procedure, FCC Public Notice DA 00-705 - Filing and Measurement Guidelines for Frequency Hopping Spread Spectrum Systems. This is the only method recognized by the FCC. The RF output port of the Equipment-Under-Test is directly coupled to the input of the EMC analyzer through a specialized RF connector and a 10dB passive attenuator. A fully charged battery was used for the supply voltage. The Bluetooth frequency hopping function of the EUT was enabled. The spectrum analyzer used the following settings:

1. Span = approx. 2 to 3 times the 20dB bandwidth, centered on a hopping frequency
2. RBW  $\geq$  1% of the 20dB span
3. VBW  $\geq$  RBW
4. Sweep = auto
5. Detector function = peak
6. Trace = max hold

The trace was allowed to stabilize. The EUT was transmitting at its maximum data rate. The marker-to-peak function was used to set the marker to the peak of the emission. The marker-delta function was used to measure 20dB down one side of the emission. The marker-delta function and marker was moved to the other side of the emission until it was even with the reference marker. The marker-delta reading at this point was the 20dB bandwidth of the emission.

### 99 % Occupied Bandwidth

The transmitter shall be operated at its maximum carrier power measured under normal test conditions.

The span of the analyzer shall be set to capture all products of the modulation process, including the emission skirts. The resolution bandwidth shall be set to as close to 1% of the selected span as is possible without being below 1%. The video bandwidth shall be set to 3 times the resolution bandwidth. Video averaging is not permitted. Where practical, a sampling detector shall be used since a peak or, peak hold, may produce a wider bandwidth than actual. The trace data points are recovered and are directly summed in linear terms. The recovered amplitude data points, beginning at the lowest frequency, are placed in a running sum until 0.5% of the total is reached and that frequency recorded. The process is repeated for the highest frequency data points. This frequency is recorded.

**7.5. Test Result**

Model Number	CS1A13		
Test Item	20dB RF Bandwidth and 99 % Occupied Bandwidth		
Test Mode	Mode 2: GFSK Link Mode		
Date of Test	07/18/2013	Test Site	TE02
Frequency (MHz)	20dB RF Bandwidth (MHz)	99 % Occupied Bandwidth (MHz)	Limit (MHz)
2402	0.995	0.888	----
2441	1.012	0.895	----
2480	1.021	0.902	----

Model Number	CS1A13		
Test Item	20dB RF Bandwidth and 99 % Occupied Bandwidth		
Test Mode	Mode 4: 8DPSK Link Mode		
Date of Test	07/18/2013	Test Site	TE02
Frequency (MHz)	20dB RF Bandwidth (MHz)	99 % Occupied Bandwidth (MHz)	Limit (MHz)
2402	1.340	1.206	----
2441	1.346	1.218	----
2480	1.371	1.223	----

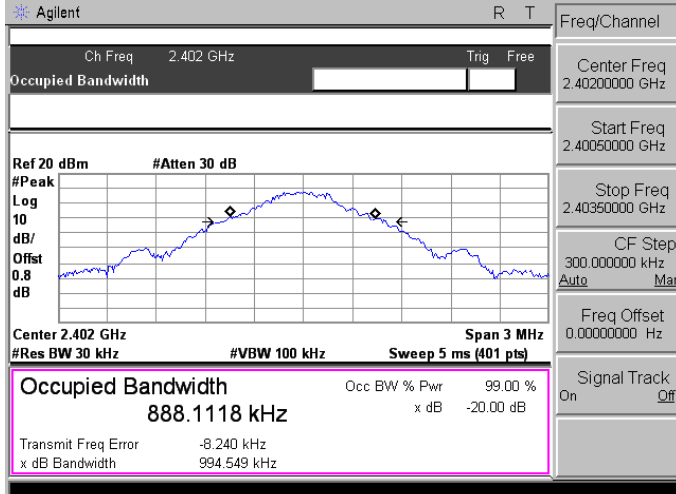
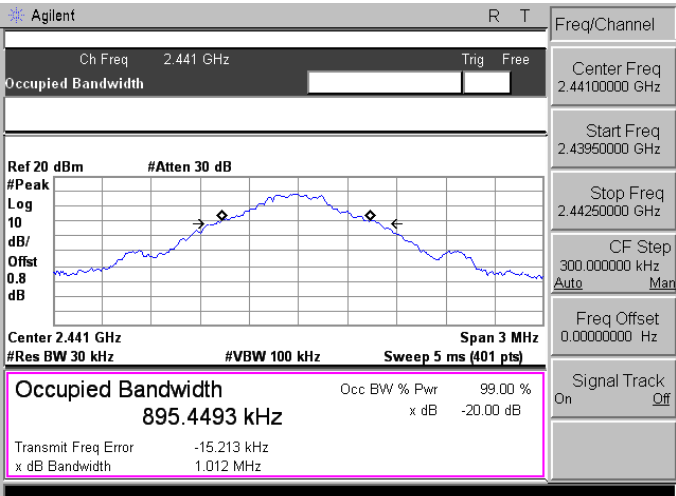
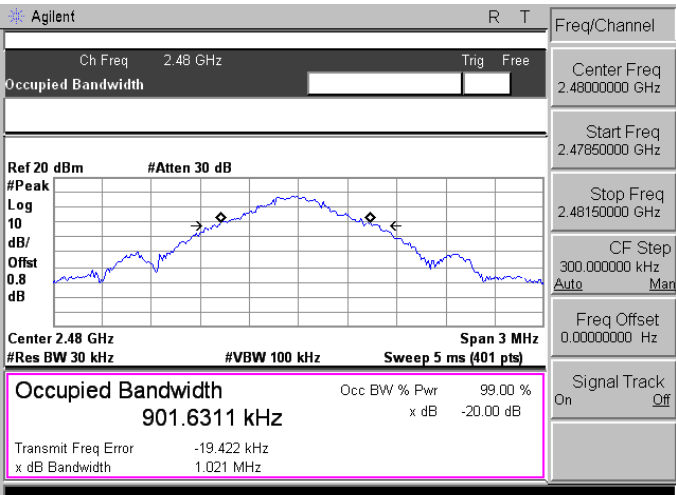

**7.6. Test Graphs**

Mode 2: GFSK Link Mode	
2402	
2441	
2480	

Mode 4: 8DPSK Link Mode	
2402	<p>Agilent R T</p> <p>Ch Freq 2.402 GHz Trig Free</p> <p>Occupied Bandwidth</p> <p>Ref 20 dBm #Atten 30 dB</p> <p>#Peak Log 10 dB/Offset 0.8 dB</p> <p>Center 2.402 GHz Span 3 MHz #Res BW 30 kHz #VBW 100 kHz Sweep 5 ms (401 pts)</p> <p><b>Occupied Bandwidth</b> Occ BW % Pwr 99.00 % 1.2061 MHz x dB -20.00 dB</p> <p>Transmit Freq Error -12.573 kHz x dB Bandwidth 1.340 MHz</p> <p>Freq/Channel Center Freq 2.40200000 GHz Start Freq 2.40050000 GHz Stop Freq 2.40350000 GHz CF Step 300.000000 kHz Auto Man Freq Offset 0.00000000 Hz Signal Track On Off</p>
2441	<p>Agilent R T</p> <p>Ch Freq 2.441 GHz Trig Free</p> <p>Occupied Bandwidth</p> <p>Ref 20 dBm #Atten 30 dB</p> <p>#Peak Log 10 dB/Offset 0.8 dB</p> <p>Center 2.441 GHz Span 3 MHz #Res BW 30 kHz #VBW 100 kHz Sweep 5 ms (401 pts)</p> <p><b>Occupied Bandwidth</b> Occ BW % Pwr 99.00 % 1.2181 MHz x dB -20.00 dB</p> <p>Transmit Freq Error -23.155 kHz x dB Bandwidth 1.346 MHz</p> <p>Freq/Channel Center Freq 2.44100000 GHz Start Freq 2.43950000 GHz Stop Freq 2.44250000 GHz CF Step 300.000000 kHz Auto Man Freq Offset 0.00000000 Hz Signal Track On Off</p>
2480	<p>Agilent R T</p> <p>Ch Freq 2.48 GHz Trig Free</p> <p>Occupied Bandwidth</p> <p>Ref 20 dBm #Atten 30 dB</p> <p>#Peak Log 10 dB/Offset 0.8 dB</p> <p>Center 2.48 GHz Span 3 MHz #Res BW 30 kHz #VBW 100 kHz Sweep 5 ms (401 pts)</p> <p><b>Occupied Bandwidth</b> Occ BW % Pwr 99.00 % 1.2227 MHz x dB -20.00 dB</p> <p>Transmit Freq Error -30.698 kHz x dB Bandwidth 1.371 MHz</p> <p>Freq/Channel Center Freq 2.48000000 GHz Start Freq 2.47850000 GHz Stop Freq 2.48150000 GHz CF Step 300.000000 kHz Auto Man Freq Offset 0.00000000 Hz Signal Track On Off</p>

## 8 Carrier Frequency Separation Measurement

### 8.1. Limit

Title 47 of the CFR, Part 15 Subpart (c) 15.247(a)(1)(i) requires the measurement of the bandwidth of the transmission between the -20 dB points on the transmitted spectrum. The results of this test determine the limits for channel spacing. The channel spacing shall be a minimum of 25 kHz or the 20 dB bandwidth.

### 8.2. Test Setup

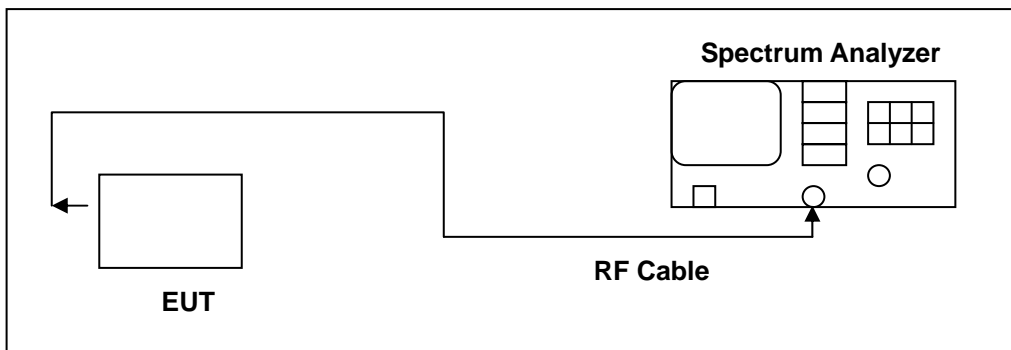

### 8.3. Test Instruments

Equipment	Manufacturer	Model Number	Serial Number	Cal. Date	Remark
Spectrum Analyzer	Agilent	E4445A	MY45300744	12/19/2012	(1)
Test Site	ATL	TE02	TE02	N.C.R.	-----

Remark: (1) Calibration period 1 year. (2) Calibration period 2 years.

NOTE: N.C.R. = No Calibration Request.

### 8.4. Test Procedure

Testing must be done according to this procedure, FCC Public Notice DA 00-705 - Filing and Measurement Guidelines for Frequency Hopping Spread Spectrum Systems. This is the only method recognized by the FCC. The RF output port of the Equipment-Under-Test is directly coupled to the input of the EMC analyzer through a specialized RF connector and a 10dB passive attenuator. A fully charged battery was used for the supply voltage. The Bluetooth transmitter of the V6 had its hopping function enabled. The following spectrum analyzer settings were used:

1. Span = wide enough to capture the peaks of two adjacent channels
2. Resolution (or IF) Bandwidth (RBW)  $\geq$  1% of the span
3. Video (or Average) Bandwidth (VBW)  $\geq$  RBW
4. Sweep = auto
5. Detector function = peak
6. Trace = max hold

The trace was allowed to stabilize. The marker-delta function was used to determine the separation between the peaks of the adjacent channels.

**8.5. Test Result**

Model Number	CS1A13		
Test Item	Carrier Frequency Separation		
Test Mode	Mode 2: GFSK Link Mode		
Date of Test	07/18/2013	Test Site	TE02
Frequency (MHz)	Measurement (MHz)		Limit (MHz)
2441	1		> 0.601

Model Number	CS1A13		
Test Item	Carrier Frequency Separation		
Test Mode	Mode 4: 8DPSK Link Mode		
Date of Test	07/18/2013	Test Site	TE02
Frequency (MHz)	Measurement (MHz)		Limit (MHz)
2441	1		> 0.815

8.6. Test Graphs

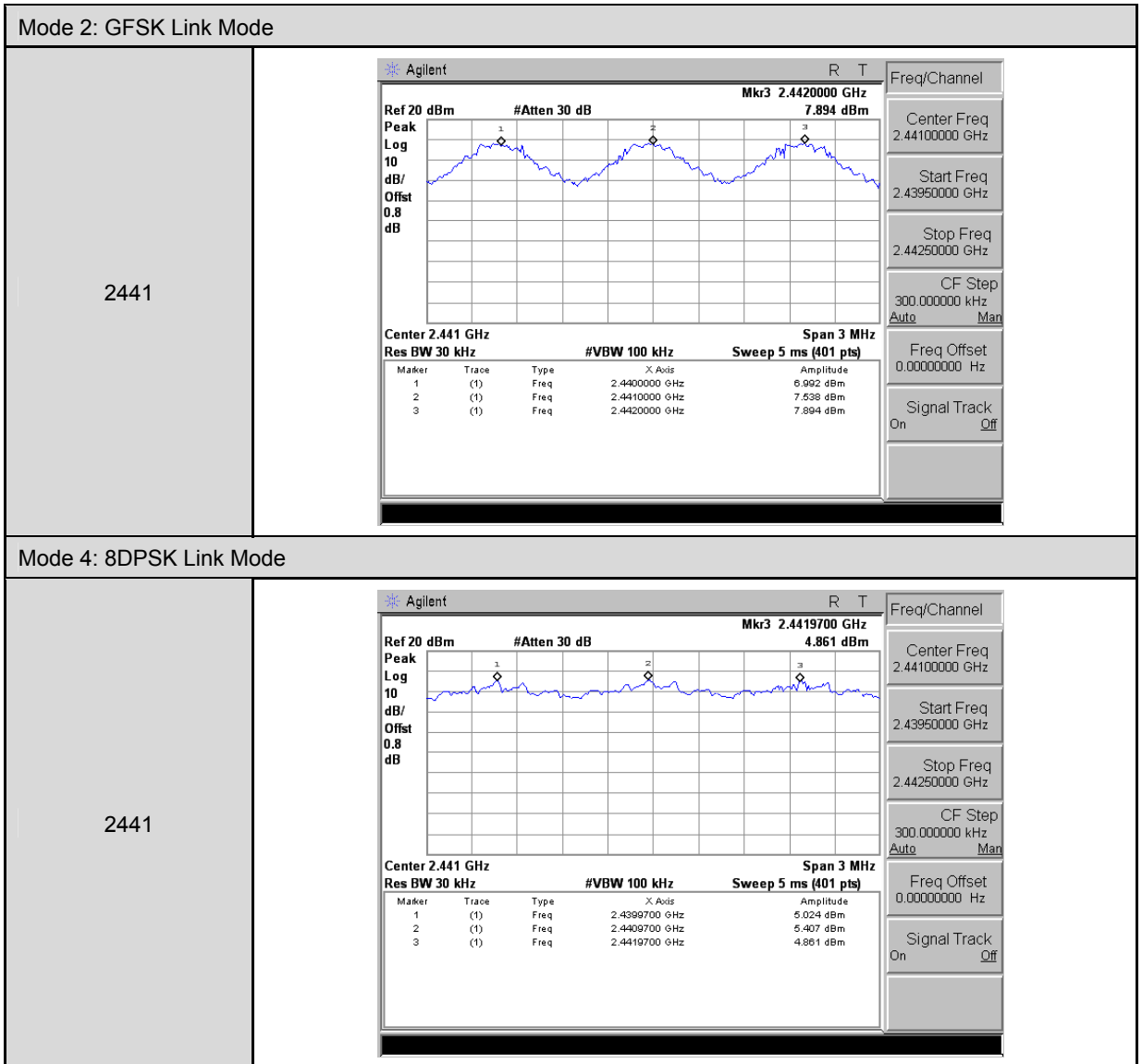

## 9 Number of Hopping Measurement

### 9.1. Limit

Frequency hopping systems in the 2400–2483.5 MHz band shall use at least 15 channels.

### 9.2. Test Setup

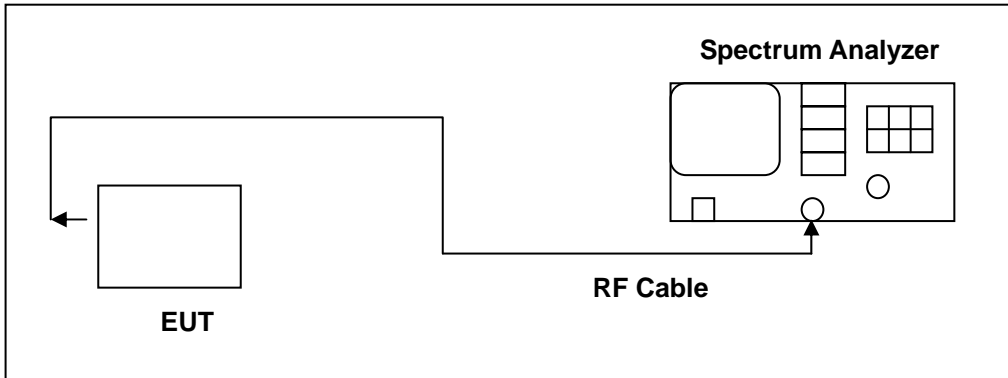

### 9.3. Test Instruments

Equipment	Manufacturer	Model Number	Serial Number	Cal. Date	Remark
Spectrum Analyzer	Agilent	E4445A	MY45300744	12/19/2012	(1)
Test Site	ATL	TE02	TE02	N.C.R.	-----

Remark: (1) Calibration period 1 year. (2) Calibration period 2 years.

NOTE: N.C.R. = No Calibration Request.

### 9.4. Test Procedure

Testing must be done according to this procedure, FCC Public Notice DA 00-705 - Filing and Measurement Guidelines for Frequency Hopping Spread Spectrum Systems. This is the only method recognized by the FCC. The RF output port of the Equipment-Under-Test is directly coupled to the input of the EMC analyzer through a specialized RF connector and a 10dB passive attenuator. A fully charged battery was used for the supply voltage. The Bluetooth frequency hopping function of the EUT was enabled. The spectrum analyzer used the following settings:

1. Span = the frequency band of operation
2. RBW  $\geq$  1% of the span
3. VBW  $\geq$  RBW
4. Sweep = auto
5. Detector function = peak
6. Trace = max hold

The trace was allowed to stabilize.

**9.5. Test Result**

Model Number	CS1A13		
Test Item	Number of Hopping		
Test Mode	Mode 2: GFSK Link Mode		
Date of Test	07/18/2013	Test Site	TE02
Frequency Range (MHz)	Measurement (ch)		Limit (ch)
2402 - 2480	79		> 15

Model Number	CS1A13		
Test Item	Number of Hopping		
Test Mode	Mode 4: 8DPSK Link Mode		
Date of Test	07/18/2013	Test Site	TE02
Frequency Range (MHz)	Measurement (ch)		Limit (ch)
2402 - 2480	79		> 15

**9.6. Test Graphs**

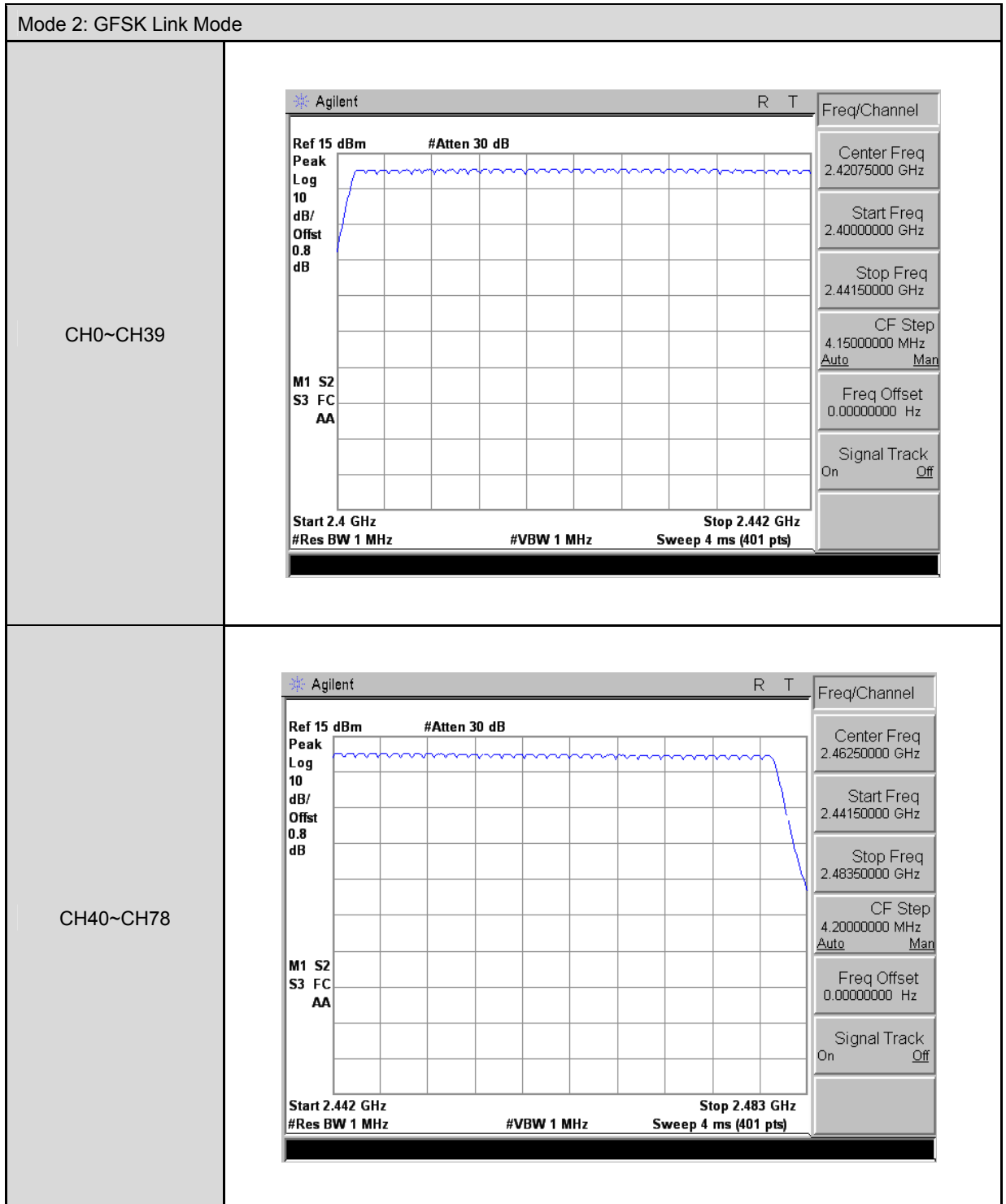



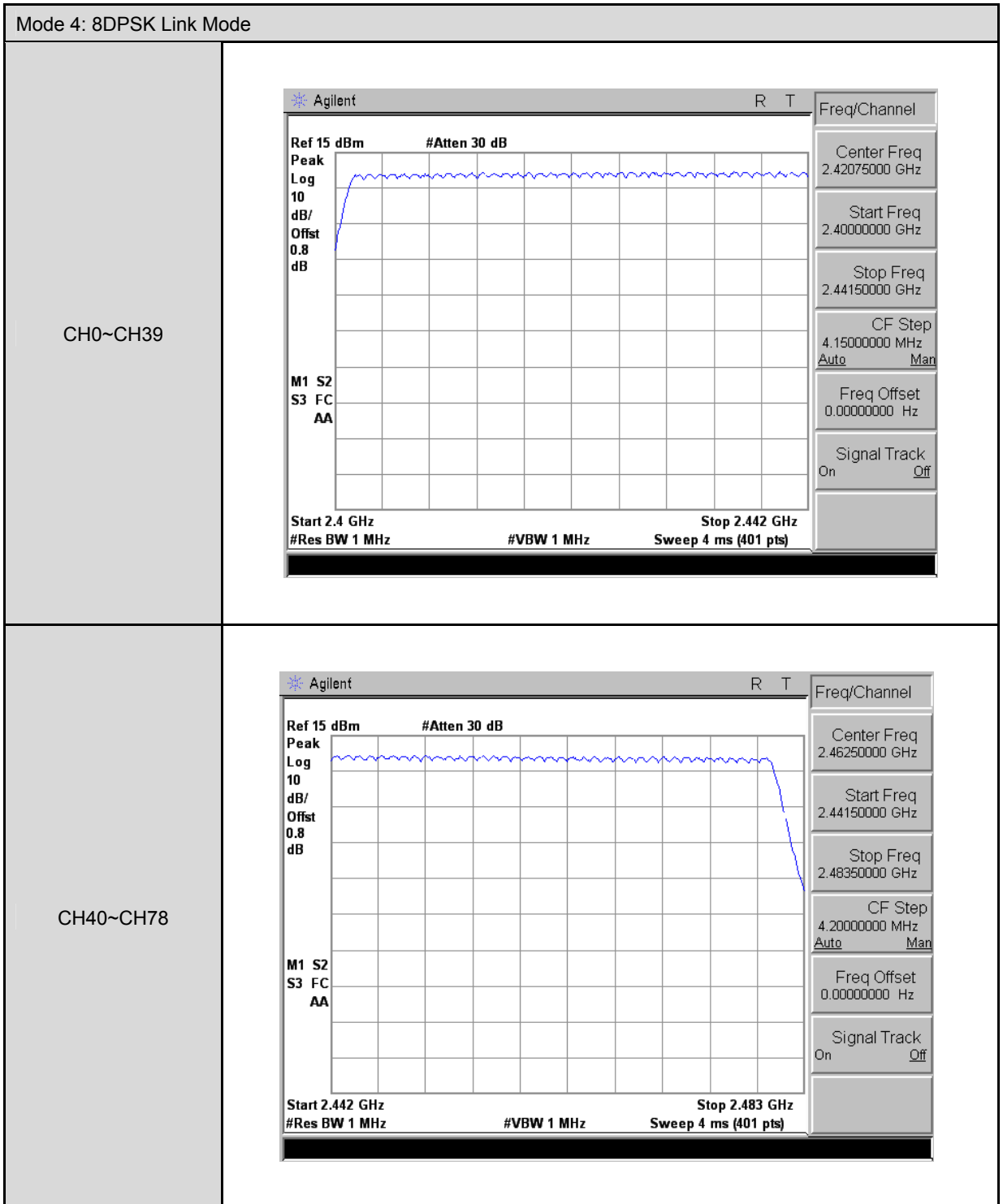

## 10 Time of Occupancy (Dwell Time) Measurement

### 10.1. Limit

The average time of occupancy on any channel shall not be greater than 0.4 seconds within a period of 0.4 seconds multiplied by the number of hopping channels employed.

### 10.2. Test Setup

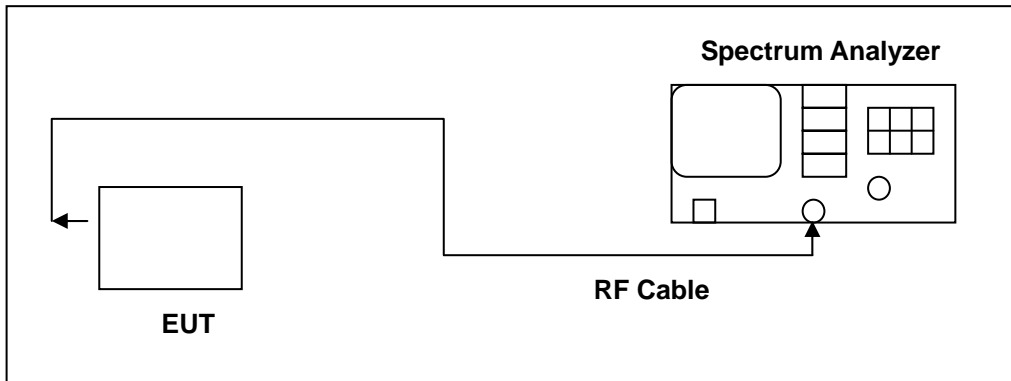

### 10.3. Test Instruments

Equipment	Manufacturer	Model Number	Serial Number	Cal. Date	Remark
Spectrum Analyzer	Agilent	E4445A	MY45300744	12/19/2012	(1)
Test Site	ATL	TE02	TE02	N.C.R.	-----

Remark: (1) Calibration period 1 year. (2) Calibration period 2 years.

NOTE: N.C.R. = No Calibration Request.

### 10.4. Test Procedure

Testing must be done according to this procedure, FCC Public Notice DA 00-705 - Filing and Measurement Guidelines for Frequency Hopping Spread Spectrum Systems. This is the only method recognized by the FCC. The RF output port of the Equipment-Under-Test is directly coupled to the input of the EMC analyzer through a specialized RF connector and a 10dB passive attenuator. A fully charged battery was used for the supply voltage. The Bluetooth hopping function of the EUT was enabled. The following spectrum analyzer settings were used:

1. Span = zero span, centered on a hopping channel
2. RBW = 1 MHz
3. VBW  $\geq$  RBW
4. Sweep = as necessary to capture the entire dwell time per hopping channel
5. Detector function = peak
6. Trace = max hold

The marker-delta function was used to determine the dwell time.

**10.5. Test Result**

Model Number	CS1A13		
Test Item	Time of Occupancy (Dwell Time)		
Test Mode	Mode 2: GFSK Link Mode		
Date of Test	07/18/2013	Test Site	TE02
DH1			
Cycle Calculate	79CH * 0.4 = 31.6 (sec)		
The EUT Hopping Number per Sec	1600 times/sec		
Each Channel Dwell Times per Sec	800/79CH = 10.13(times/sec)		
Each Channel Dwell Times (1)	0.475	ms (sec)	
Each Channel Dwell Times on Cycle(2)	31.6 * 10.13 = 320.108(times)		
Dwell Times on Cycle (1) * (2)	152.0513	ms (sec)	
LIMIT(msec)	< = 400		
DH3			
Cycle Calculate	79CH * 0.4 = 31.6 (sec)		
The EUT Hopping Number per Sec	1600 times/sec		
Each Channel Dwell Times per Sec	400/79CH = 5.1(times/sec)		
Each Channel Dwell Times (1)	1.725	ms (sec)	
Each Channel Dwell Times on Cycle(2)	31.6 * 5.1 = 161.16(times)		
Dwell Times on Cycle (1) * (2)	278.0010	ms (sec)	
LIMIT(msec)	< = 400		
DH5			
Cycle Calculate	79CH * 0.4 = 31.6 (sec)		
The EUT Hopping Number per Sec	1600 times/sec		
Each Channel Dwell Times per Sec	266.7/79CH = 3.37(times/sec)		
Each Channel Dwell Times (1)	2.975	ms (sec)	
Each Channel Dwell Times on Cycle(2)	31.6 * 3.37 = 106.492(times)		
Dwell Times on Cycle (1) * (2)	316.8137	ms (sec)	
LIMIT(msec)	< = 400		

Model Number	CS1A13		
Test Item	Time of Occupancy (Dwell Time)		
Test Mode	Mode 4: 8DPSK Link Mode		
Date of Test	07/18/2013	Test Site	TE02
3DH1			
Cycle Calculate	$79CH * 0.4 = 31.6 \text{ (sec)}$		
The EUT Hopping Number per Sec	1600 times/sec		
Each Channel Dwell Times per Sec	$800/79CH = 10.13(\text{times/sec})$		
Each Channel Dwell Times (1)	0.475	ms (sec)	
Each Channel Dwell Times on Cycle(2)	$31.6 * 10.13 = 320.108(\text{times})$		
Dwell Times on Cycle (1) * (2)	152.0513	ms (sec)	
LIMIT(msec)	< = 400		
3DH3			
Cycle Calculate	$79CH * 0.4 = 31.6 \text{ (sec)}$		
The EUT Hopping Number per Sec	1600 times/sec		
Each Channel Dwell Times per Sec	$400/79CH = 5.1(\text{times/sec})$		
Each Channel Dwell Times (1)	1.725	ms (sec)	
Each Channel Dwell Times on Cycle(2)	$31.6 * 5.1 = 161.16(\text{times})$		
Dwell Times on Cycle (1) * (2)	278.0010	ms (sec)	
LIMIT(msec)	< = 400		
3DH5			
Cycle Calculate	$79CH * 0.4 = 31.6 \text{ (sec)}$		
The EUT Hopping Number per Sec	1600 times/sec		
Each Channel Dwell Times per Sec	$266.7/79CH = 3.37(\text{times/sec})$		
Each Channel Dwell Times (1)	2.975	ms (sec)	
Each Channel Dwell Times on Cycle(2)	$31.6 * 3.37 = 106.492(\text{times})$		
Dwell Times on Cycle (1) * (2)	316.8137	ms (sec)	
LIMIT(msec)	< = 400		

**10.6. Test Graphs**

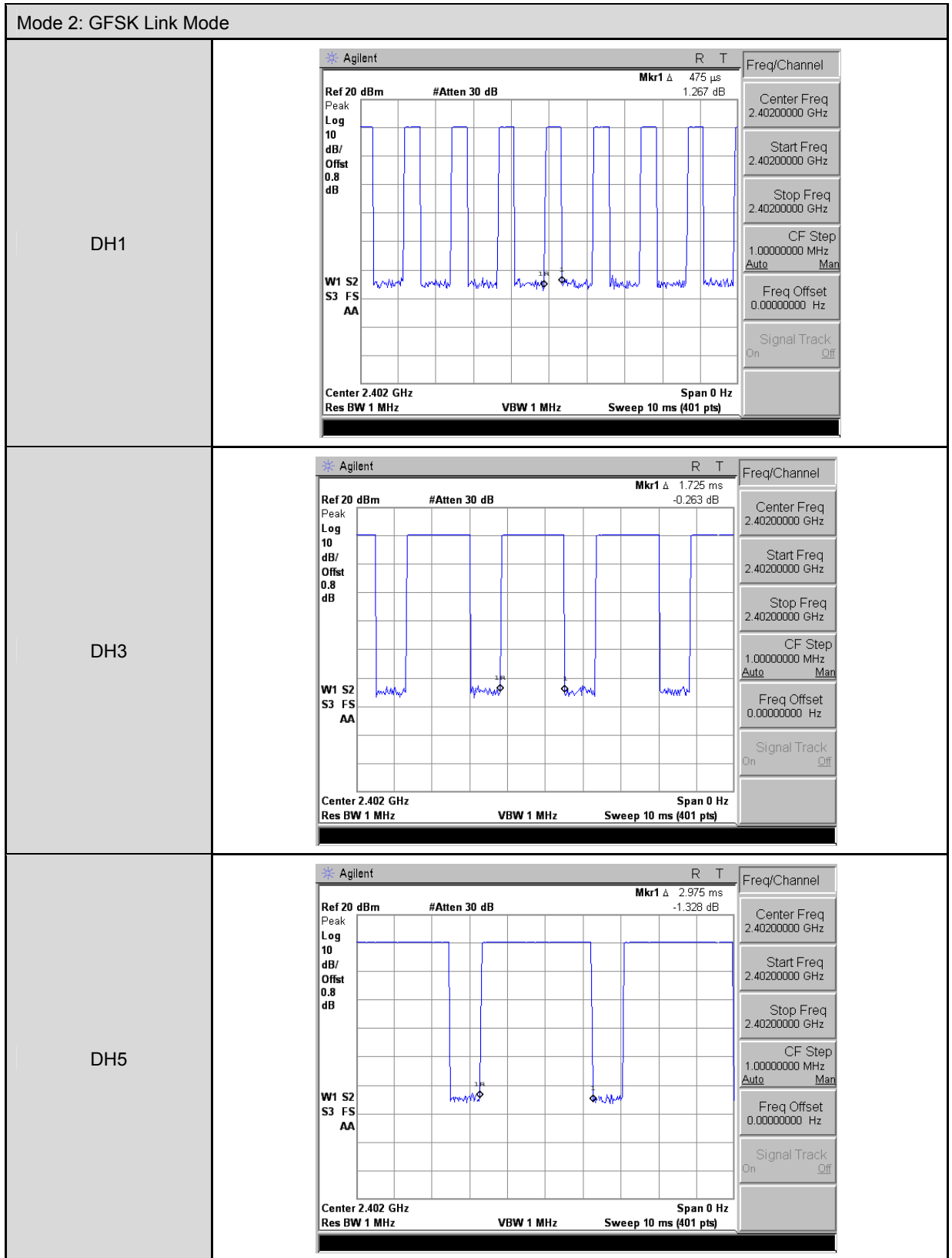

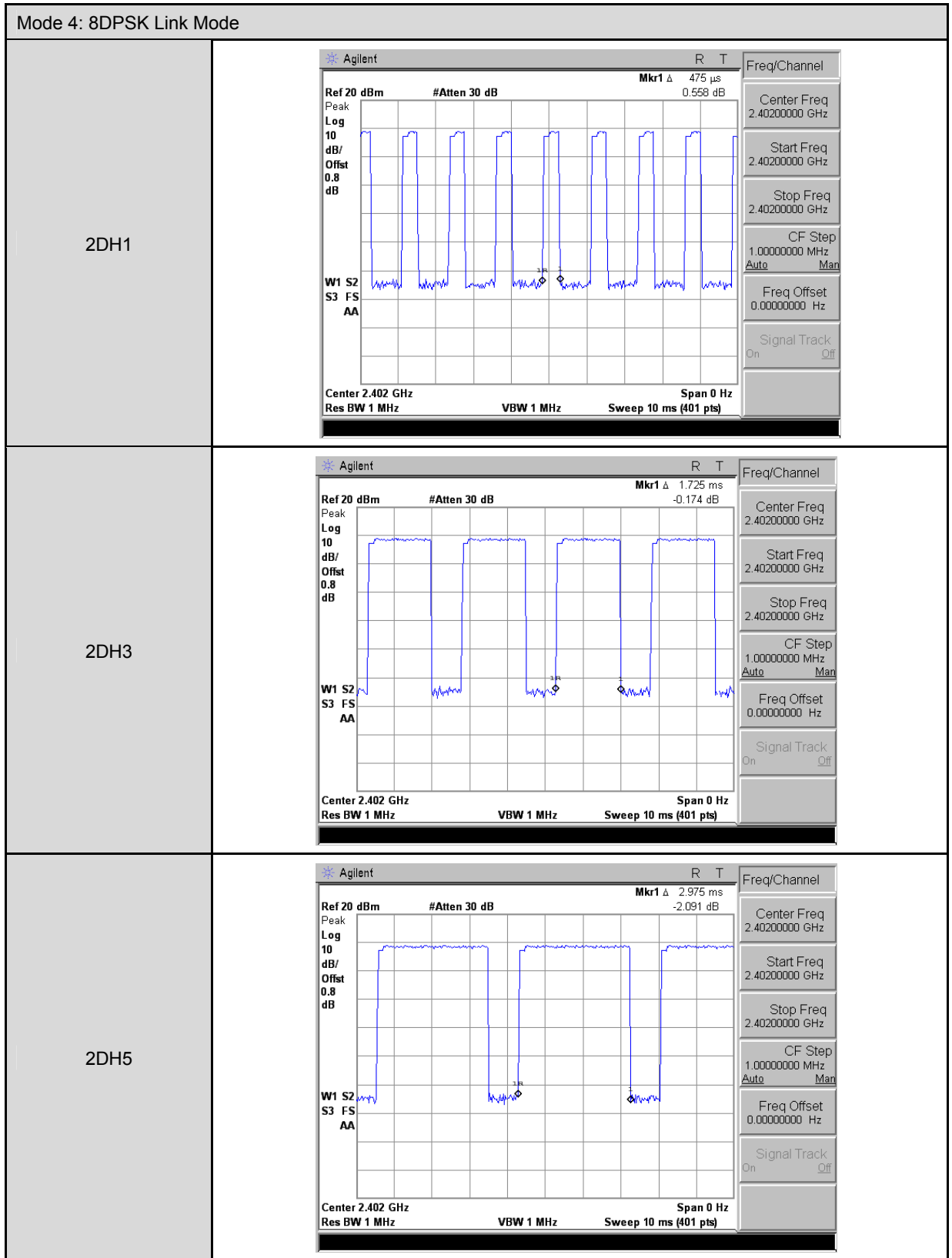

## 11 Out of Band Conducted Emissions Measurement

### 11.1. Limit

In any 100 kHz bandwidth outside the frequency band in which the spread spectrum or digitally modulated intentional radiator is operating, the radio frequency power that is produced by the intentional radiator shall be at least 20 dB below that in the 100 kHz bandwidth within the band that contains the highest level of the desired power

### 11.2. Test Setup

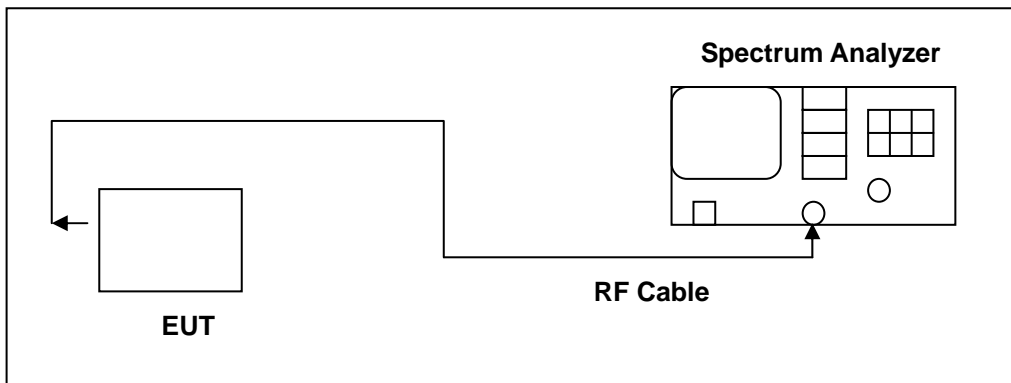

### 11.3. Test Instruments

Equipment	Manufacturer	Model Number	Serial Number	Cal. Date	Remark
Spectrum Analyzer	Agilent	E4445A	MY45300744	12/19/2012	(1)
Spectrum Analyzer	Agilent	E4408B	MY45107753	07/11/2013	(1)
Test Site	ATL	TE02	TE02	N.C.R.	----

Remark: (1) Calibration period 1 year. (2) Calibration period 2 years.

NOTE: N.C.R. = No Calibration Request.

### 11.4. Test Procedure

Testing must be done according to this procedure, FCC Public Notice DA 00-705 - Filing and Measurement Guidelines for Frequency Hopping Spread Spectrum Systems. This is the only method recognized by the FCC. In any 100 kHz bandwidth outside the EUT pass band, the RF power produced by the modulation products of the spreading sequence, the information sequence, and the carrier frequency shall be at least 20 dB below that of the maximum in-band 100 kHz emission, antenna output of the EUT was coupled directly to spectrum analyzer; if an external attenuator and/or cable was used, these losses are compensated for with the analyzer OFFSET function. All other types of emissions from the EUT shall meet the general limits for radiated frequencies outside the pass band. The test was performed at 3 channels (Channel 0, 39, 78)

**11.5. Test Graphs**

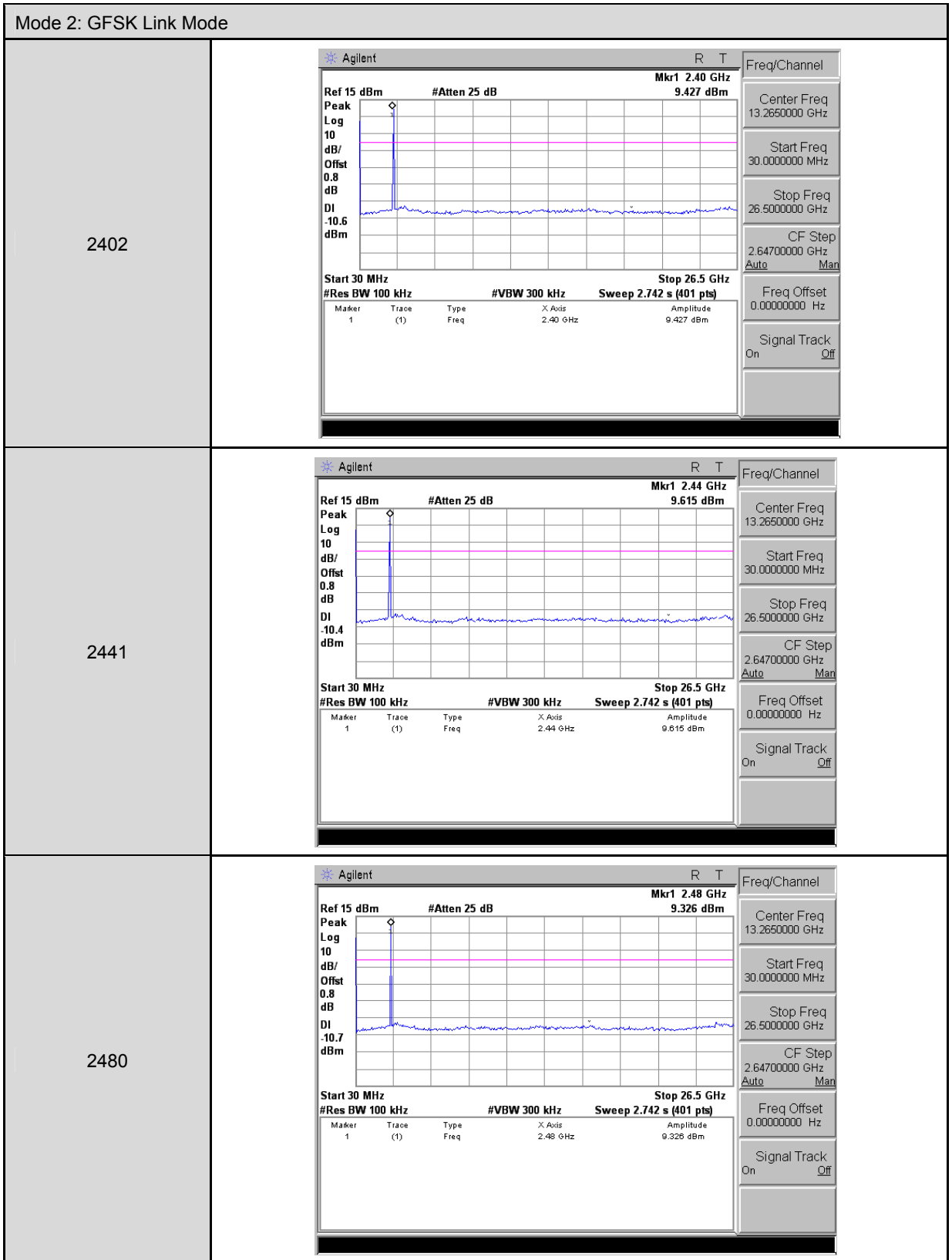



Mode 2: GFSK Link Mode \_ Un-hopping

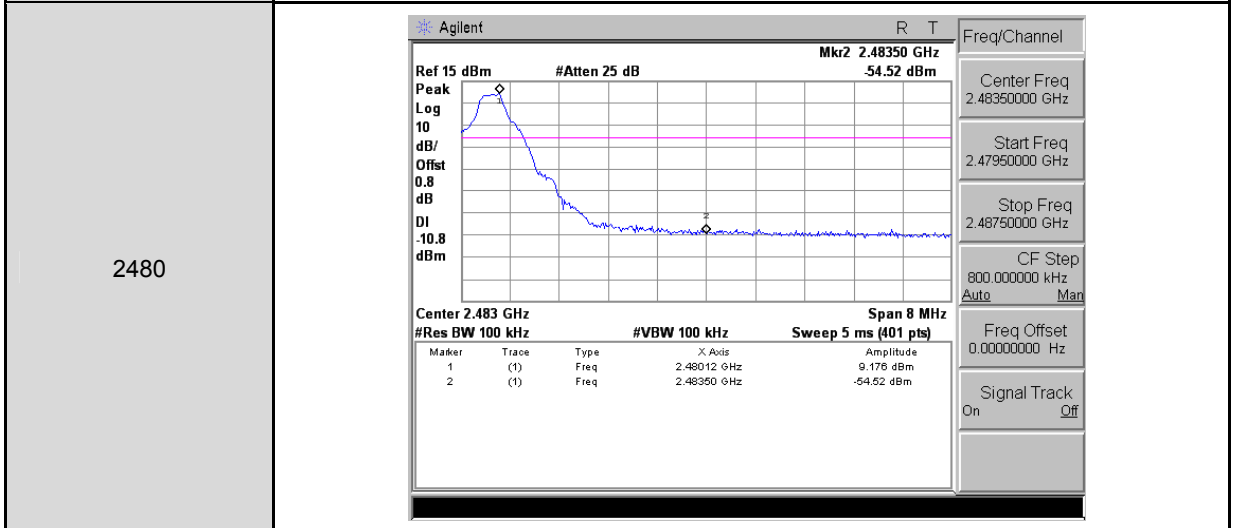
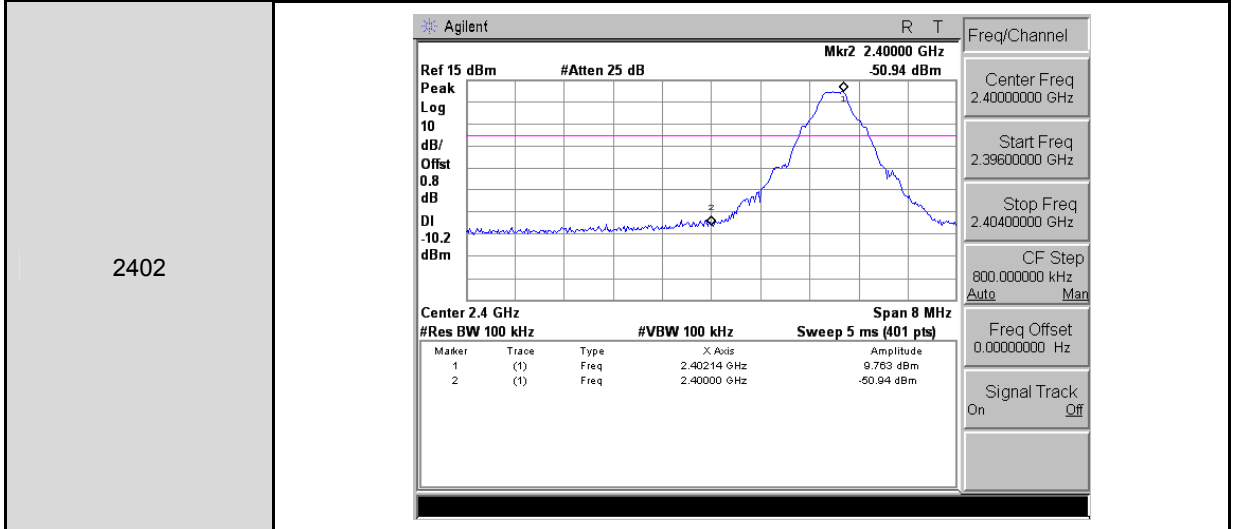

Mode 2: GFSK Link Mode \_ Hopping

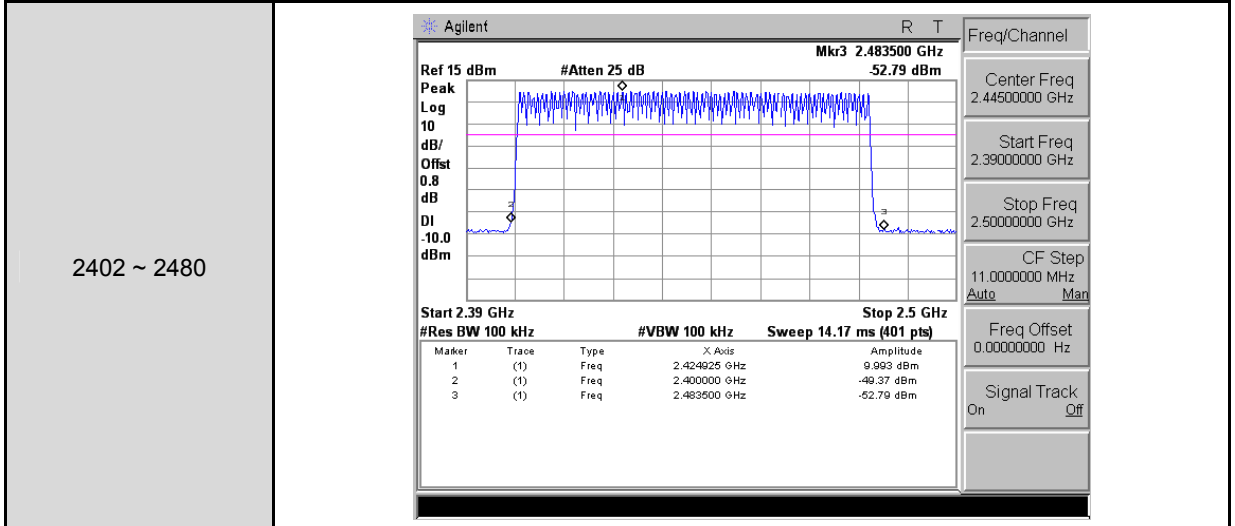

Mode 4: 8DPSK Link Mode											
2402	<p>Agilent R T Mkr1 2.40 GHz 5.494 dBm</p> <p>Ref 15 dBm #Atten 25 dB</p> <p>Peak Log 10 dB/Offst 0.8 dB DI -14.5 dBm</p> <p>Start 30 MHz #Res BW 100 kHz #VBW 300 kHz Stop 26.5 GHz Sweep 2.742 s (401 pts)</p> <table border="1"> <thead> <tr> <th>Marker</th> <th>Trace</th> <th>Type</th> <th>X Axis</th> <th>Amplitude</th> </tr> </thead> <tbody> <tr> <td>1</td> <td>(1)</td> <td>Freq</td> <td>2.40 GHz</td> <td>5.494 dBm</td> </tr> </tbody> </table> <p>Freq/Channel Center Freq 13.2650000 GHz Start Freq 30.0000000 MHz Stop Freq 26.5000000 GHz CF Step 2.64700000 GHz Auto Man Freq Offset 0.00000000 Hz Signal Track On Off</p>	Marker	Trace	Type	X Axis	Amplitude	1	(1)	Freq	2.40 GHz	5.494 dBm
Marker	Trace	Type	X Axis	Amplitude							
1	(1)	Freq	2.40 GHz	5.494 dBm							
2441	<p>Agilent R T Mkr1 2.44 GHz 5.376 dBm</p> <p>Ref 15 dBm #Atten 25 dB</p> <p>Peak Log 10 dB/Offst 0.8 dB DI -14.6 dBm</p> <p>Start 30 MHz #Res BW 100 kHz #VBW 300 kHz Stop 26.5 GHz Sweep 2.742 s (401 pts)</p> <table border="1"> <thead> <tr> <th>Marker</th> <th>Trace</th> <th>Type</th> <th>X Axis</th> <th>Amplitude</th> </tr> </thead> <tbody> <tr> <td>1</td> <td>(1)</td> <td>Freq</td> <td>2.44 GHz</td> <td>5.376 dBm</td> </tr> </tbody> </table> <p>Freq/Channel Center Freq 13.2650000 GHz Start Freq 30.0000000 MHz Stop Freq 26.5000000 GHz CF Step 2.64700000 GHz Auto Man Freq Offset 0.00000000 Hz Signal Track On Off</p>	Marker	Trace	Type	X Axis	Amplitude	1	(1)	Freq	2.44 GHz	5.376 dBm
Marker	Trace	Type	X Axis	Amplitude							
1	(1)	Freq	2.44 GHz	5.376 dBm							
2480	<p>Agilent R T Mkr1 2.48 GHz 4.439 dBm</p> <p>Ref 15 dBm #Atten 25 dB</p> <p>Peak Log 10 dB/Offst 0.8 dB DI -15.6 dBm</p> <p>Start 30 MHz #Res BW 100 kHz #VBW 300 kHz Stop 26.5 GHz Sweep 2.742 s (401 pts)</p> <table border="1"> <thead> <tr> <th>Marker</th> <th>Trace</th> <th>Type</th> <th>X Axis</th> <th>Amplitude</th> </tr> </thead> <tbody> <tr> <td>1</td> <td>(1)</td> <td>Freq</td> <td>2.48 GHz</td> <td>4.439 dBm</td> </tr> </tbody> </table> <p>Freq/Channel Center Freq 13.2650000 GHz Start Freq 30.0000000 MHz Stop Freq 26.5000000 GHz CF Step 2.64700000 GHz Auto Man Freq Offset 0.00000000 Hz Signal Track On Off</p>	Marker	Trace	Type	X Axis	Amplitude	1	(1)	Freq	2.48 GHz	4.439 dBm
Marker	Trace	Type	X Axis	Amplitude							
1	(1)	Freq	2.48 GHz	4.439 dBm							

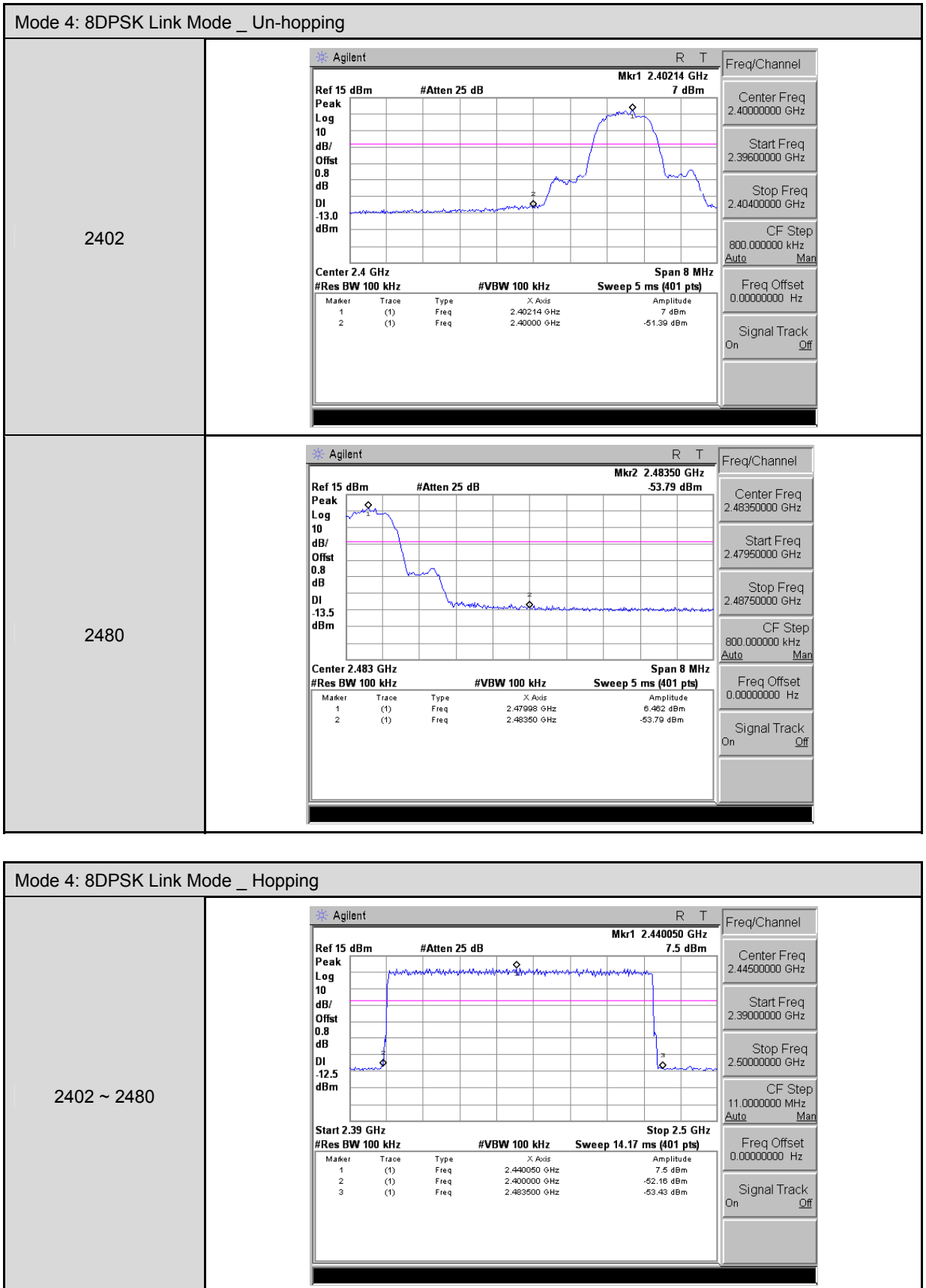

## 12 Band Edges Measurement

### 12.1. Limit

In any 100 kHz bandwidth outside the frequency band in which the spread spectrum or digitally modulated intentional radiator is operating, the radio frequency power that is produced by the intentional radiator shall be at least 20 dB below that in the 100 kHz bandwidth within the band that contains the highest level of the desired power

### 12.2. Test Setup

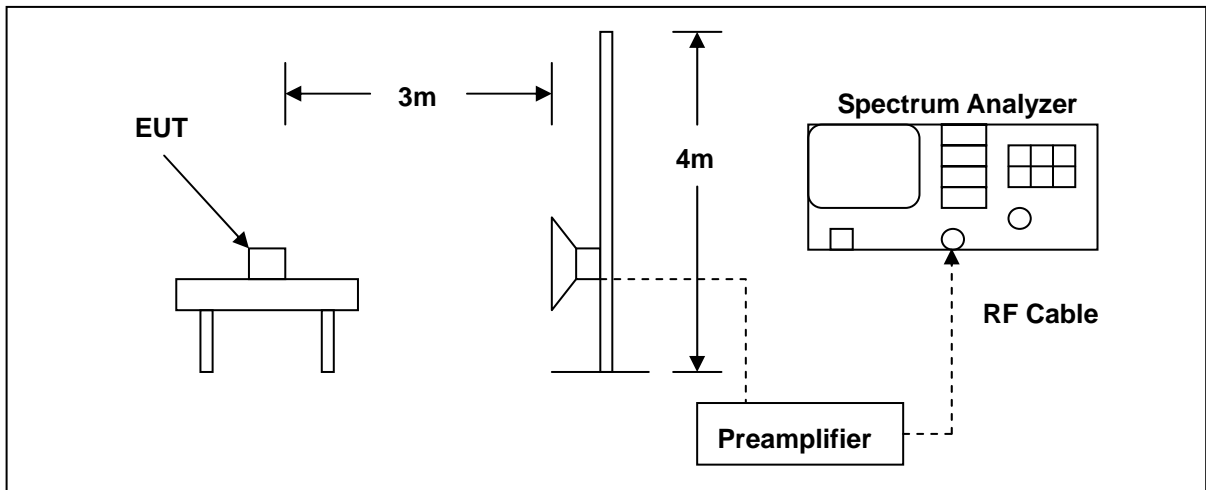

### 12.3. Test Instruments

Equipment	Manufacturer	Model Number	Serial Number	Cal. Date	Remark
Spectrum Analyzer	Agilent	E4408B	MY45107753	07/11/2013	(1)
Pre Amplifier	Agilent	8449B	3008A02237	02/21/2013	(1)
Horn Antenna	SCHWARZBECK MESS-ELEKTRONIK	9120D	9120D-550	06/10/2013	(1)
Test Site	ATL	TE01	888001	08/28/2012	(1)

Remark: (1) Calibration period 1 year. (2) Calibration period 2 years.

NOTE: N.C.R. = No Calibration Request.

## 12.4. Test Procedure

Testing must be done according to this procedure, FCC Public Notice DA 00-705 - Filing and Measurement Guidelines for Frequency Hopping Spread Spectrum Systems. This is the only method recognized by the FCC. The emissions on the harmonics frequencies, the limits, and the margin of compliance are presented. These tests were made when the transmitter was in full radiated power. The additional test was performed to show compliance with the requirement at the band-edge frequency 2483.5 MHz and up to 2500 MHz and at 2390.0 MHz.

The transmitter was configured with the worst case antenna and setup to transmit at the highest channel. Then the field strength was measured at 2483.5 MHz.

The transmitter was then configured with the worst case antenna and setup to transmit at the lowest channel. Then the field strength was measured at 2390.0 MHz. These tests were performed at 4 different bit rates.

For measurements the resolution bandwidth is set to 1 MHz, and then the video bandwidth is set to 1 MHz for peak measurements and 10 Hz for average measurements.

**12.5. Test Result**

Standard:	FCC Part 15C	Test Distance:	3m
Test item:	Radiated Emission	Power:	AC 120V/60Hz
Model Number:	CS1A13	Temp.(°C)/Hum.(%RH):	26(°C)/60%RH
Mode:	Mode 2	Date:	07/18/2013
Frequency:	2402 MHz	Test By:	Fly Lu
Ant.Polar.:	Horizontal		

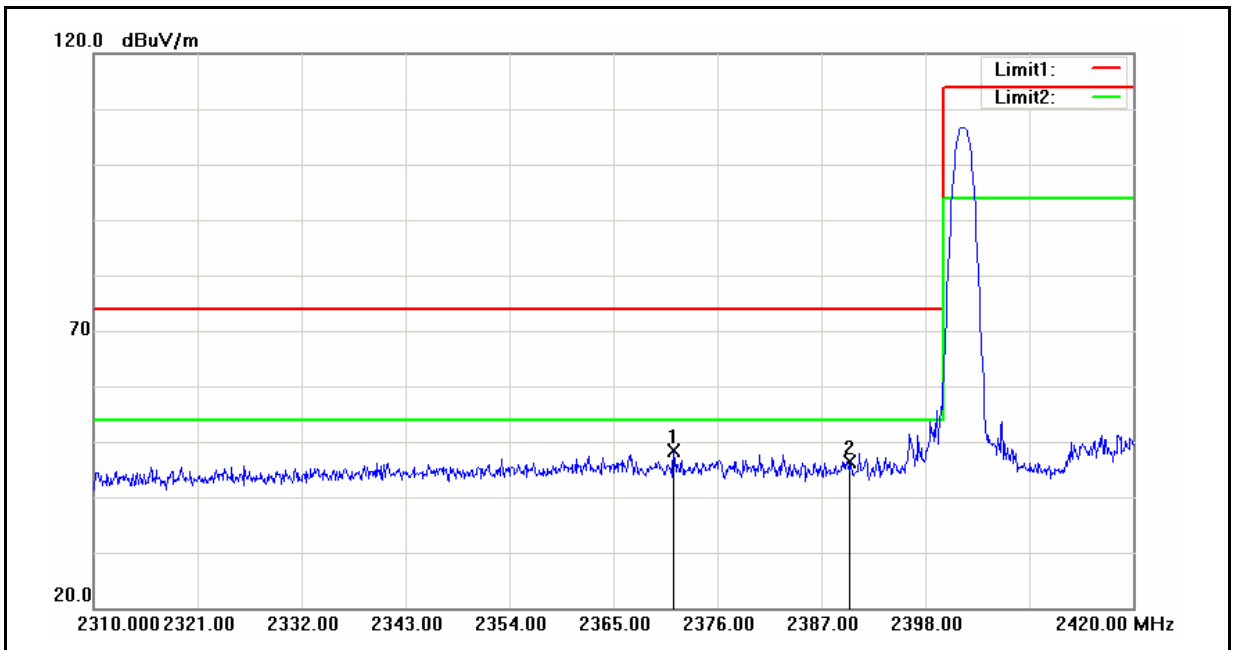

No.	Frequency (MHz)	Reading (dBuV)	Correct Factor (dB/m)	Result (dBuV/m)	Limit (dBuV/m)	Margin (dB)	Remark
1	2371.380	44.68	3.76	48.44	74.00	-25.56	peak
2	2390.000	42.48	3.88	46.36	74.00	-27.64	peak

Standard:	FCC Part 15C	Test Distance:	3m
Test item:	Radiated Emission	Power:	AC 120V/60Hz
Model Number:	CS1A13	Temp.(°C)/Hum.(%RH):	26(°C)/60%RH
Mode:	Mode 2	Date:	07/18/2013
Frequency:	2402 MHz	Test By:	Fly Lu
Ant.Polar.:	Vertical		

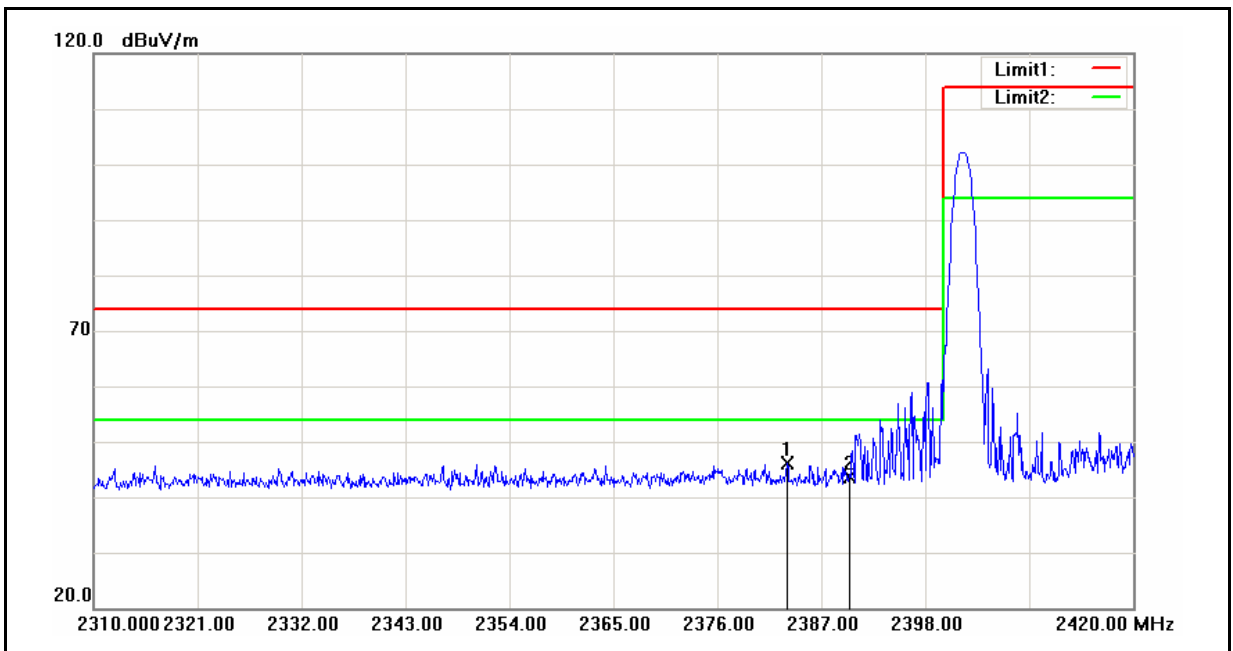

No.	Frequency (MHz)	Reading (dBuV)	Correct Factor (dB/m)	Result (dBuV/m)	Limit (dBuV/m)	Margin (dB)	Remark
1	2383.370	42.18	3.83	46.01	74.00	-27.99	peak
2	2390.000	39.85	3.88	43.73	74.00	-30.27	peak

Standard:	FCC Part 15C	Test Distance:	3m
Test item:	Radiated Emission	Power:	AC 120V/60Hz
Model Number:	CS1A13	Temp.(°C)/Hum.(%RH):	26(°C)/60%RH
Mode:	Mode 2	Date:	07/18/2013
Frequency:	2480 MHz	Test By:	Fly Lu
Ant.Polar.:	Horizontal		

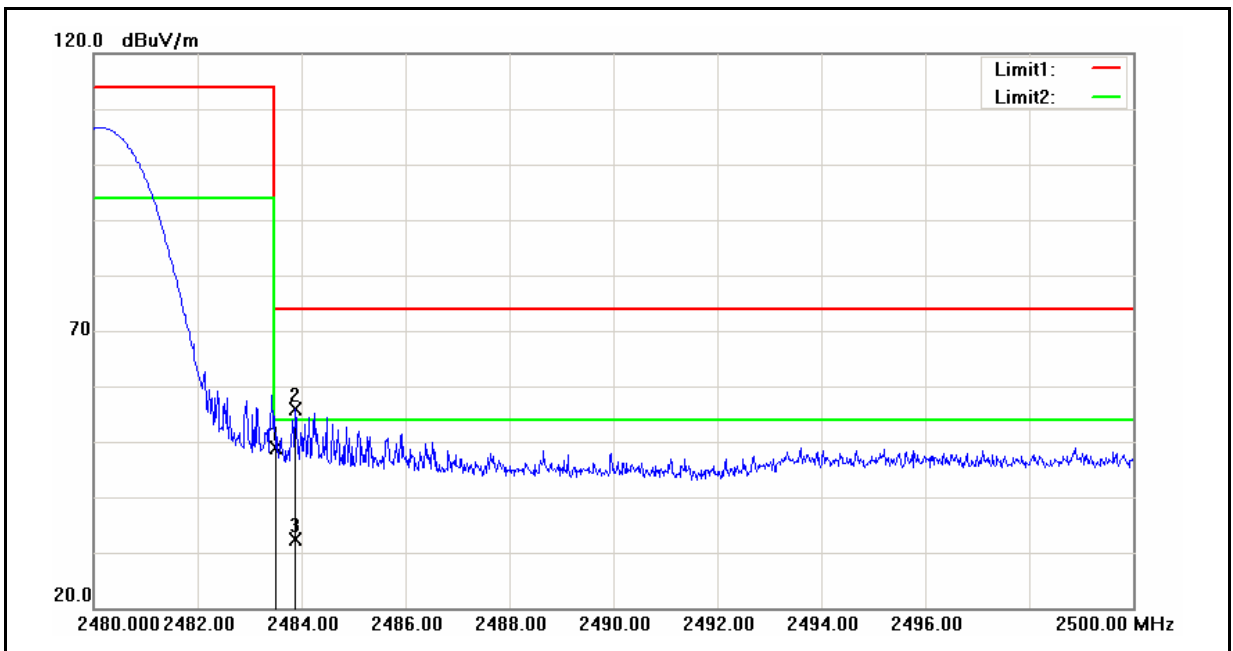

No.	Frequency (MHz)	Reading (dBuV)	Correct Factor (dB/m)	Result (dBuV/m)	Limit (dBuV/m)	Margin (dB)	Remark
1	2483.500	44.41	4.50	48.91	74.00	-25.09	peak
2	2483.880	51.37	4.51	55.88	74.00	-18.12	peak
3	2483.880	27.90	4.51	32.41	54.00	-21.59	AVG



Standard:	FCC Part 15C	Test Distance:	3m
Test item:	Radiated Emission	Power:	AC 120V/60Hz
Model Number:	CS1A13	Temp.(°C)/Hum.(%RH):	26(°C)/60%RH
Mode:	Mode 2	Date:	07/18/2013
Frequency:	2480 MHz	Test By:	Fly Lu
Ant.Polar.:	Vertical		

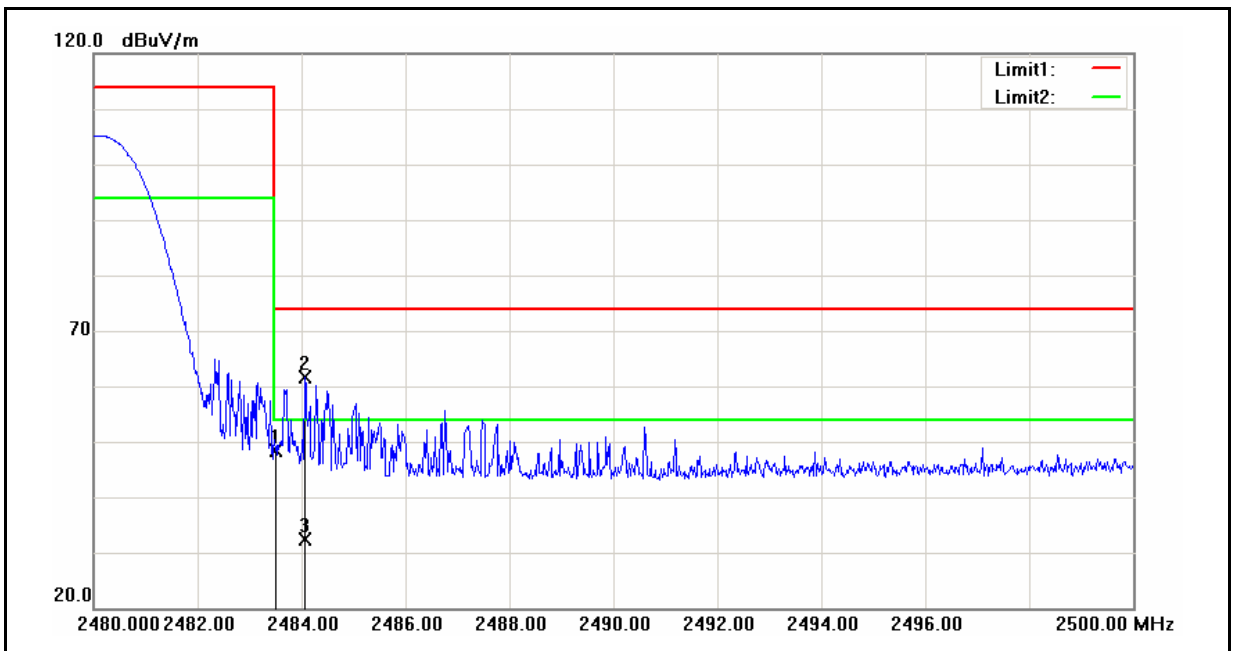

No.	Frequency (MHz)	Reading (dBuV)	Correct Factor (dB/m)	Result (dBuV/m)	Limit (dBuV/m)	Margin (dB)	Remark
1	2483.500	43.88	4.50	48.38	74.00	-25.62	peak
2	2484.060	57.23	4.51	61.74	74.00	-12.26	peak
3	2484.060	27.85	4.51	32.36	54.00	-21.64	AVG

Standard:	FCC Part 15C	Test Distance:	3m
Test item:	Radiated Emission	Power:	AC 120V/60Hz
Model Number:	CS1A13	Temp.(°C)/Hum.(%RH):	26(°C)/60%RH
Mode:	Mode 4	Date:	07/18/2013
Frequency:	2402 MHz	Test By:	Fly Lu
Ant.Polar.:	Horizontal		

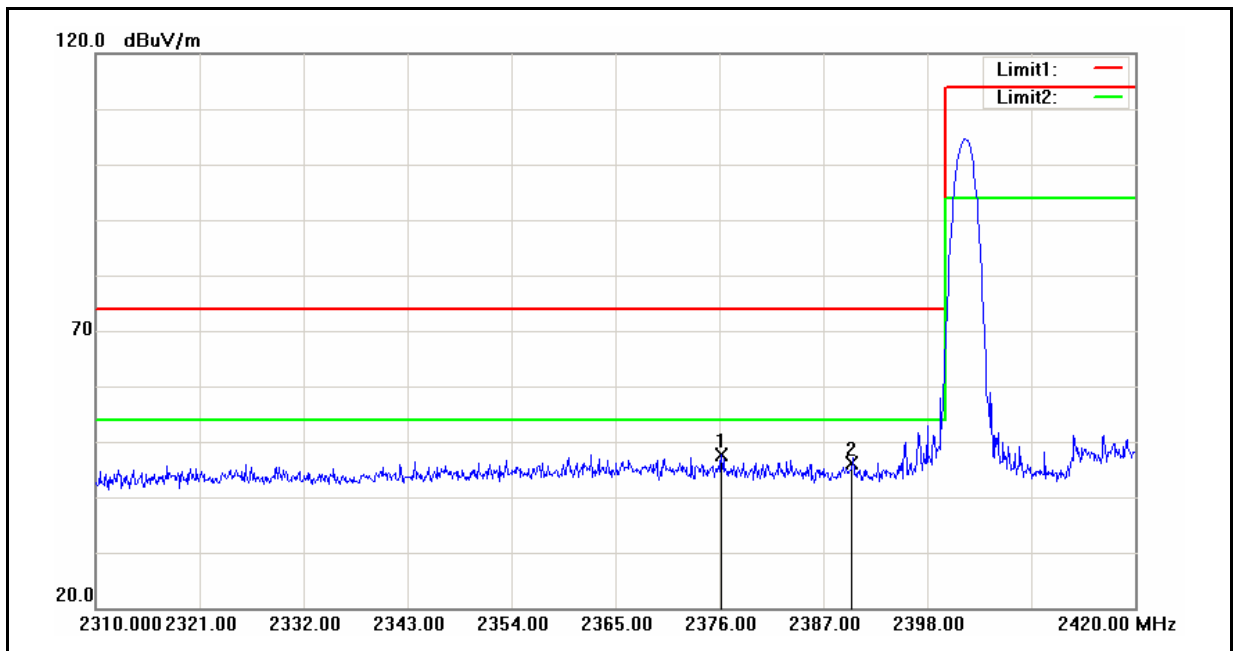

No.	Frequency (MHz)	Reading (dBuV)	Correct Factor (dB/m)	Result (dBuV/m)	Limit (dBuV/m)	Margin (dB)	Remark
1	2376.220	43.90	3.78	47.68	74.00	-26.32	peak
2	2390.000	42.17	3.88	46.05	74.00	-27.95	peak

Standard:	FCC Part 15C	Test Distance:	3m
Test item:	Radiated Emission	Power:	AC 120V/60Hz
Model Number:	CS1A13	Temp.(°C)/Hum.(%RH):	26(°C)/60%RH
Mode:	Mode 4	Date:	07/18/2013
Frequency:	2402 MHz	Test By:	Fly Lu
Ant.Polar.:	Vertical		

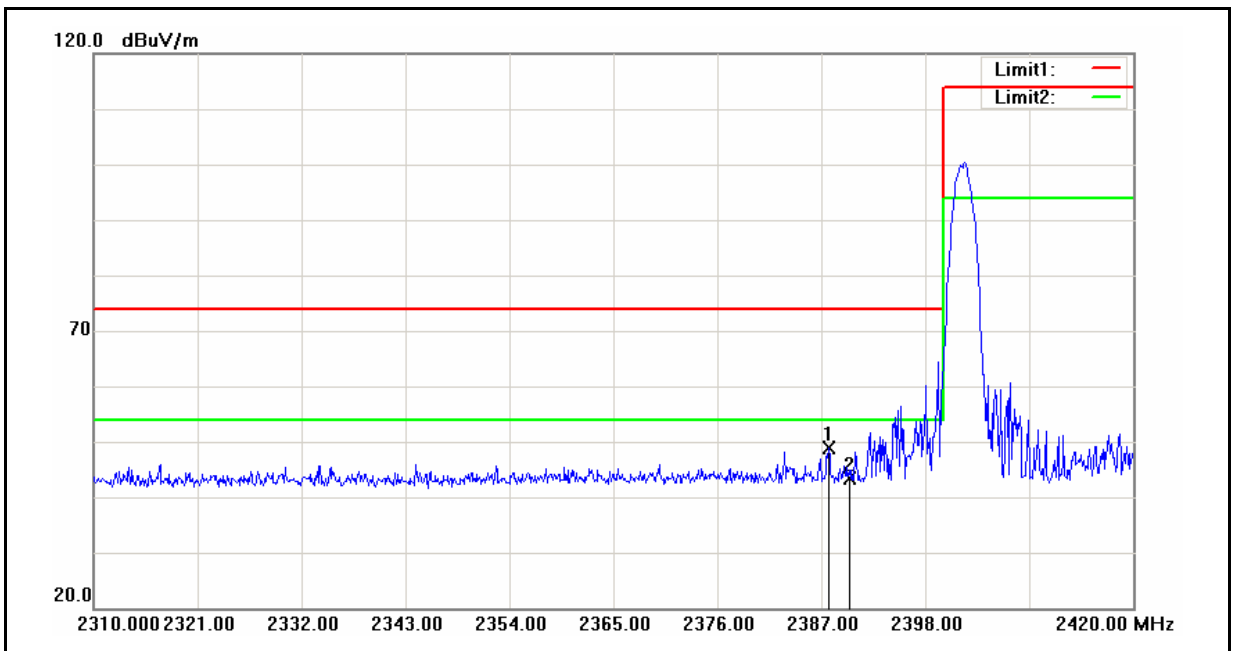

No.	Frequency (MHz)	Reading (dBuV)	Correct Factor (dB/m)	Result (dBuV/m)	Limit (dBuV/m)	Margin (dB)	Remark
1	2387.770	44.91	3.86	48.77	74.00	-25.23	peak
2	2390.000	39.45	3.88	43.33	74.00	-30.67	peak

Standard:	FCC Part 15C	Test Distance:	3m
Test item:	Radiated Emission	Power:	AC 120V/60Hz
Model Number:	CS1A13	Temp.(°C)/Hum.(%RH):	26(°C)/60%RH
Mode:	Mode 4	Date:	07/18/2013
Frequency:	2480 MHz	Test By:	Fly Lu
Ant.Polar.:	Horizontal		

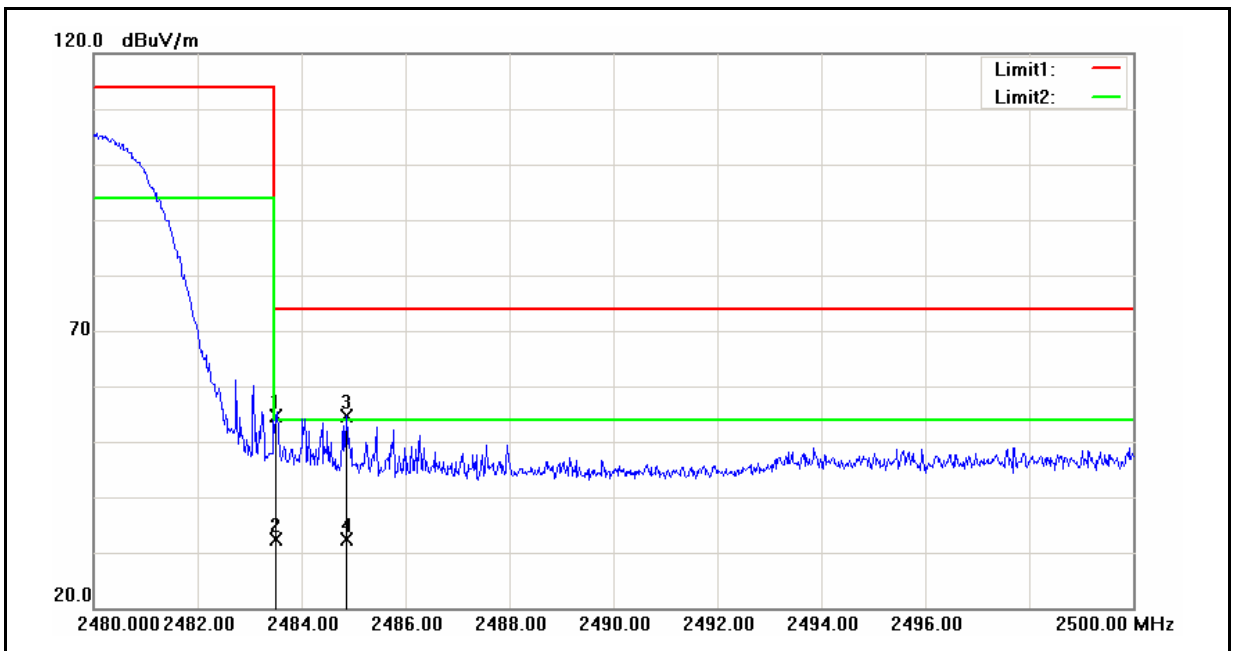

No.	Frequency (MHz)	Reading (dBuV)	Correct Factor (dB/m)	Result (dBuV/m)	Limit (dBuV/m)	Margin (dB)	Remark
1	2483.500	50.25	4.50	54.75	74.00	-19.25	peak
2	2483.500	27.94	4.50	32.44	54.00	-21.56	AVG
3	2484.860	50.16	4.51	54.67	74.00	-19.33	peak
4	2484.860	27.77	4.51	32.28	54.00	-21.72	AVG

Standard:	FCC Part 15C	Test Distance:	3m
Test item:	Radiated Emission	Power:	AC 120V/60Hz
Model Number:	CS1A13	Temp.(°C)/Hum.(%RH):	26(°C)/60%RH
Mode:	Mode 4	Date:	07/18/2013
Frequency:	2480 MHz	Test By:	Fly Lu
Ant.Polar.:	Vertical		

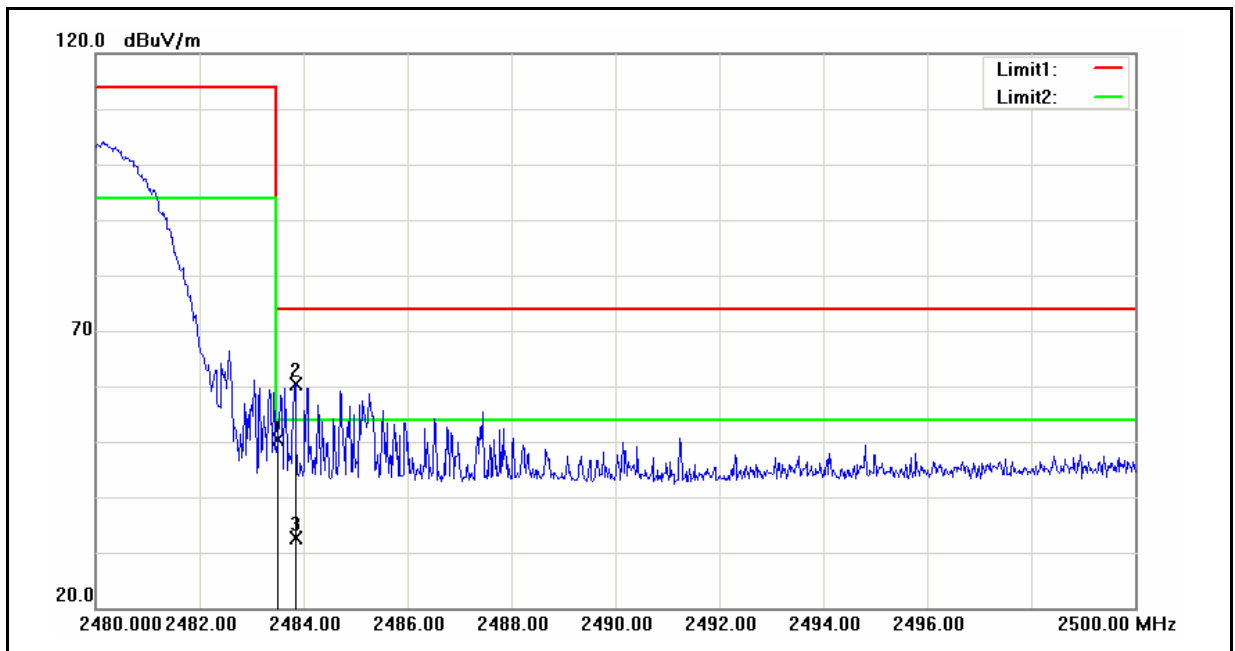

No.	Frequency (MHz)	Reading (dBuV)	Correct Factor (dB/m)	Result (dBuV/m)	Limit (dBuV/m)	Margin (dB)	Remark
1	2483.500	45.89	4.50	50.39	74.00	-23.61	peak
2	2483.840	55.78	4.51	60.29	74.00	-13.71	peak
3	2483.840	28.14	4.51	32.65	54.00	-21.35	AVG

Standard:	FCC Part 15C	Test Distance:	3m
Test item:	Radiated Emission	Power:	AC 120V/60Hz
Model Number:	CS1A13	Temp.(°C)/Hum.(%RH):	26(°C)/60%RH
Mode:	Hopping	Date:	07/18/2013
Ant.Polar.:	Horizontal	Test By:	Fly Lu

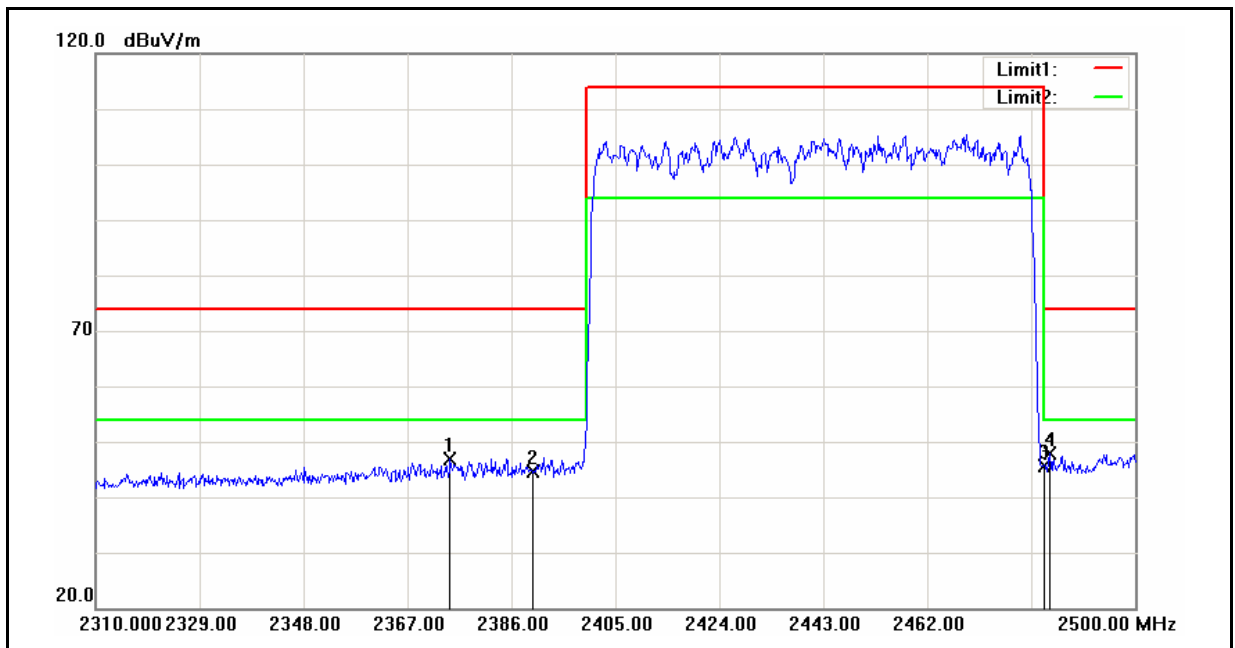

No.	Frequency (MHz)	Reading (dBuV)	Correct Factor (dB/m)	Result (dBuV/m)	Limit (dBuV/m)	Margin (dB)	Remark
1	2374.790	43.09	3.78	46.87	74.00	-27.13	peak
2	2390.000	40.73	3.88	44.61	74.00	-29.39	peak
3	2483.500	41.04	4.50	45.54	74.00	-28.46	peak
4	2484.420	43.26	4.51	47.77	74.00	-26.23	peak

Standard:	FCC Part 15C	Test Distance:	3m
Test item:	Radiated Emission	Power:	AC 120V/60Hz
Model Number:	CS1A13	Temp.(°C)/Hum.(%RH):	26(°C)/60%RH
Mode:	Hopping	Date:	07/18/2013
Ant.Polar.:	Vertical	Test By:	Fly Lu

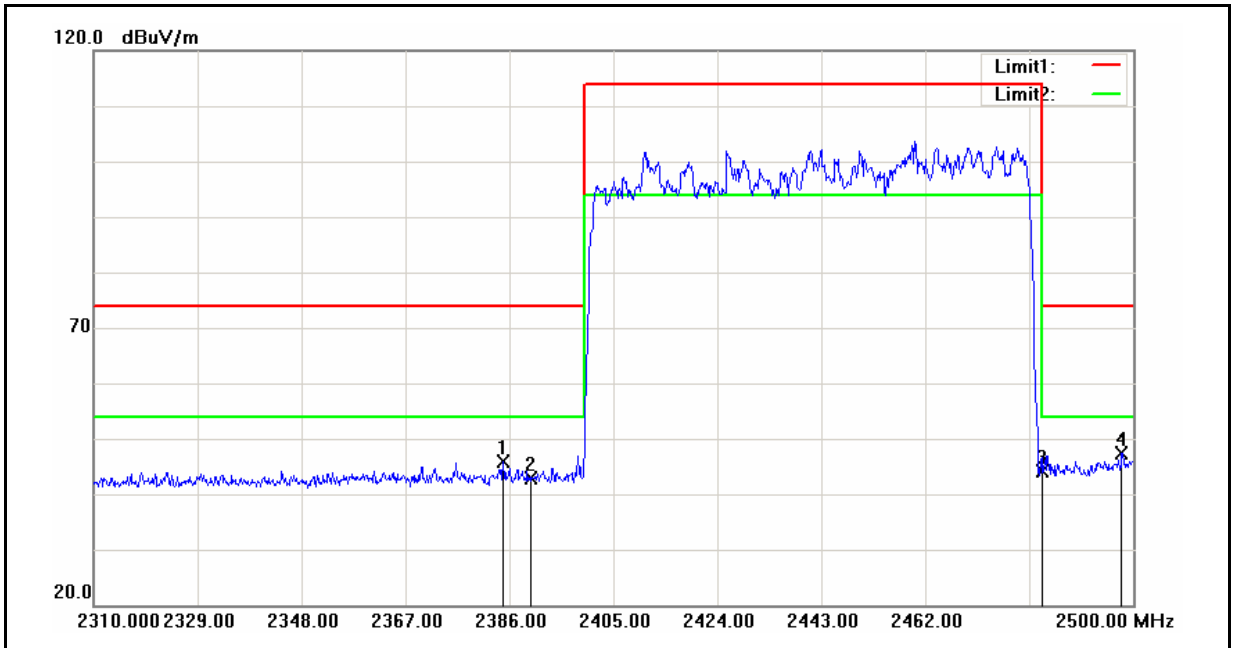

No.	Frequency (MHz)	Reading (dBuV)	Correct Factor (dB/m)	Result (dBuV/m)	Limit (dBuV/m)	Margin (dB)	Remark
1	2384.860	41.94	3.84	45.78	74.00	-28.22	peak
2	2390.000	39.07	3.88	42.95	74.00	-31.05	peak
3	2483.500	39.56	4.50	44.06	74.00	-29.94	peak
4	2497.910	42.83	4.60	47.43	74.00	-26.57	peak

## **13 Antenna Measurement**

### **13.1. Limit**

For intentional device, according to 15.203, an intentional radiator shall be designed to ensure that no antenna other than that furnished by the responsible party shall be used with the device.

And According to 15.247 (b), if transmitting antennas of directional gain greater than 6 dBi are used, the power shall be reduced by the amount in dB that the directional gain of the antenna exceeds 6dBi.

### **13.2. Antenna Connector Construction**

The antenna used in this product is Chip Antenna. And the maximum Gain of this antenna is only 3.3 dBi.