

Regulatory WLAN Antenna Information (Template)

English Language Required for Intel Regulatory Review / Approval

(OEM/ODM or antenna vendor is required to complete this document with platform antenna information.

Remove Intel references and make this your own document)

Platform information										
Brand	ODM	****End product model name	Intel platform (ex: Yes, No or NA)	Platform type (ex: regular NB, convertible PC, AIO...etc)	*SAR minimum separation (mm)					
DELL	WISTRON	P163G	YES	Regular NB	2.51					
****Please fill in exact product model name and make sure the model name is visible on product cover or any parts for end users recognize for authority inspection.										
Antenna information										
Vendor	Type		Antenna Part number (Main)				Antenna Part number (Aux)			
WISTRON	PIFA		0JG1N				0JG1N			
Peak gain w/ cable loss (dBi)*										
	2.4GHz 2400-2483.5 MHz	5.2GHz 5150-5250MHz	5.3GHz 5250-5350MHz	5.6GHz 5470-5725MHz	5.8GHz 5725-5850MHz	6.2GHz 5925-6425MHz	6.5GHz 6425-6525MHz	6.7GHz 6525-6875MHz	7.0 GHz 6875-7125MHz	
Main	2.06	2.63	2.63	4.09	4.17	4.34	4.21	4.29	4.03	
Aux	1.57	2.42	2.15	4.01	4.01	4.66	4.20	4.07	4.07	
Intel Reference Gain/Type/ Separation distance										
Antenna Type	Antenna Peak gain (In dBi)*									Distance to the end user (mm)
	2.4GHz 2400-2483.5 MHz	5.2GHz 5150-5250MHz	5.3GHz 5250-5350MHz	5.6GHz 5470-5725MHz	5.8GHz 5725-5850MHz	6.2GHz 5925-6425MHz	6.5GHz 6425-6525MHz	6.7GHz 6525-6875MHz	7.0GHz 6875-7125MHz	
Design	3.00	5.00	5.00	5.00	5.00	5.00	5.00	5.00	5.00	
PIFA	3.24	3.64	3.73	4.77	4.97	4.83	4.30	5.37	5.59	
Dipole	2.89	2.92	3.19	4.41	4.22	4.83	4.30	4.49	5.34	
Notes (marked with *)										
* SAR minimum separation (mm)										
- Regular NB: Minimum antenna-to-body (from antenna bottom to the bottom of the device)										
- Tablet / Convertible PC: Minimum antenna-to-edge (5 sides of the device)										
- Mini-tablet: Minimum antenna-to-edge (6 sides of the device)										
* 3D Peak Antenna gain should be equal or greater than -2 dBi										
- If a host integrator plans to use a lower gain antenna of the same type, additional CBP(FCC)/EDT(EU) testing need to be performed while the module is installed in the host.										

Table of contents

1. Applicable test method
2. Test & System Description
 - a. Test setup
 - b. Equipment list
3. Setup photo

[Section 1. Antenna Assembly Specifications](#)

[Section 2. Dimensioned Photos or Drawings of Antennas](#)

[Section 3. Radiation characteristics of antenna loaded in Host Platform](#)

[Section 4. Antenna Host Platform Location Information](#)

[Section 5. Antenna dimensional information for SAR evaluation](#)

[Section 6. Diagram Example of Co-Location Antenna Separation](#)

1. **Applicable test methods**

<insert test description here for test method>

[example] This test report is prepared for host antenna testing under a Full Anechoic Chamber.

2. **Test & System Description**

a. Test setup

<insert test diagram here for test site utilized>

Radiated Setup 1 GHz – 6.4 GHz

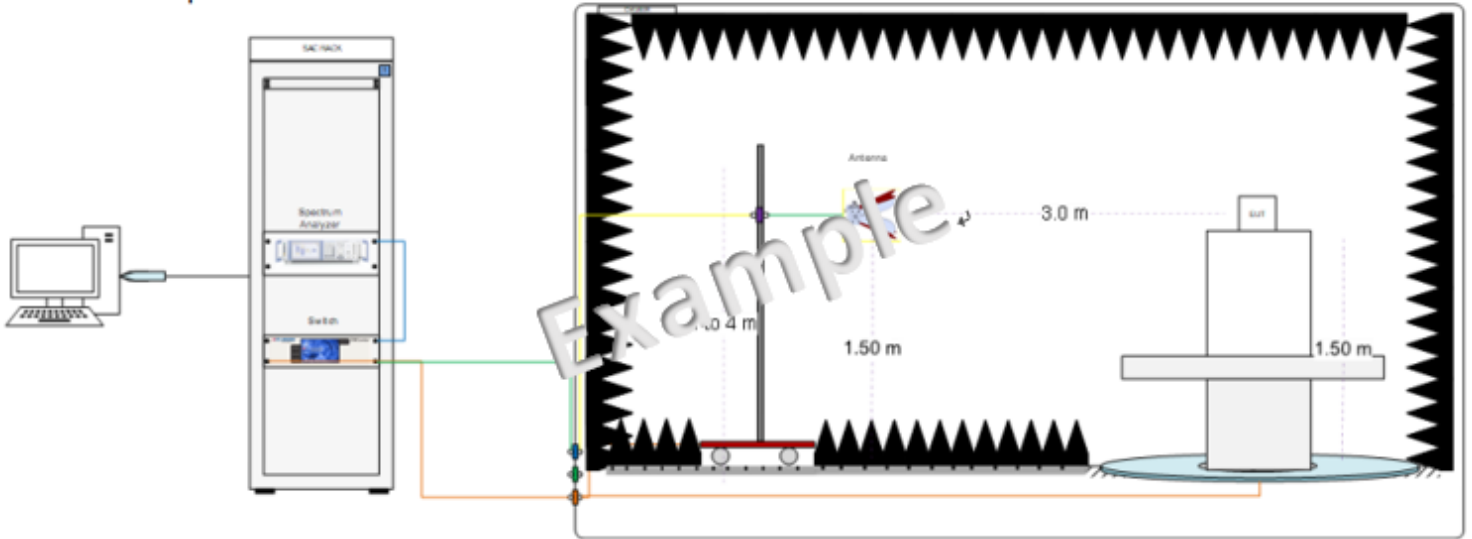

b. Equipment list

<insert test diagram here for test site utilized>

ID#	Device	Type/Model	Serial #	Manufacturer	Cal. Date	Cal. Due Date
0135	Anechoic Chamber	FACT3	5720	ETS-Lindgren	2020-07-06	2022-01-07
0136	Turn Table	ETS	-	ETS-Lindgren	N/A	N/A
0147	Switch & Positioning systems	EMC Center	00159757	ETS-Lindgren	N/A	N/A
0530	Measurement SW	EMC32, v10.40.10	100623	Rohde & Schwarz	N/A	N/A
1033	Boresight antenna mast	BAM 4.0-P	P/278/2890.01	Maturo	N/A	N/A
1076	Spectrum Analyzer	FSW43	101847	Rohde & Schwarz	2020-11-02	2022-11-02
0993	Biconical antenna 30 MHz – 1 GHz	UBAA9115 + BBVU9135 + DGA9552N	0286 + CH 9044	Schwarzbeck	2019-11-22	2021-11-22
0325	Horn antenna	3117	00157734	ETS-Lindgren	2019-08-12	2021-08-12
0141	Horn Antenna + Amplifier + HPF6.4	3117	00157734	ETS-Lindgren	2020-04-02	2022-04-02
0334	Double-Ridged Waveguide Horn with Pre-Amplifier 18 GHz to 40 GHz	3116C+PA	0139308bis + 00196308	ETS-Lindgren	2019-07-24	2021-07-24
0859	Cable 2.5m - 30MHz to 18GHz	0500990992500KE	19.23.395	Radiall	2020-11-27	2021-05-27
0206	Cable 1.2m – 18 to 40 GHz	UFA147A-0-0480- 200200	MFR 64639223720-003	Micro-coax	2020-08-25	2021-02-25
0263	Cable 1m - 1GHz to 18GHz	UFA147A	-	Utiliflex	2020-08-25	2021-02-25
0369	Cable 2m - 26.5GHz to 40GHz	794-9191-2000A	E00327	Atem	2020-08-25	2021-02-25
0371	Cable 1m – 30 MHz - 18GHz	UFB311A-0-0590- 50U50U	MFR 64639 223230-001	Micro-coax	2020-08-25	2021-02-25
1099	Cable 7m DC-18 GHz	0501051057000GX	19.35.850	Radiall	2020-11-27	2021-05-27
0809	Cable 7m - 18GHz to 40GHz	R286304009	-	Radiall	2020-08-25	2021-02-25
1098	Cable 1.5m - DC-18GHz	CBL-1.5M-SMSM+	202879	Mini-Circuits	2020-11-27	2021-05-27
0797	Temp & Humidity Logger	RA12E-TH1-RAS	RA12-D0EB1A	Avtech	2019-07-04	2021-07-04

N/A: Not Applicable

3. Setup photo

Antenna Information

Section 1. Antenna Assembly Specifications

1A Antenna Part Number	1B Manufacturer	1C Antenna Type	1D Cable Assembly Part Number and Information	Freq Range MHz	1E * Peak Gain W/ Cable loss (dBi)	1F Peak Gain w/o Cable Loss (dBi)	1G Max VSWR	1H Cable Loss (dB)
(P/N: 0JG1N) Main Antenna	Wistron	PIFA	Connector P/N: 20632-001R-37(IPEX) 50 ohm Coaxial length: 177.6mm diameter: 1.37mm	2400-2483.5	2.06	2.48	3.0	0.42
				5150-5250	2.63	3.26	3.0	0.63
				5250-5350	2.63	3.27	3.0	0.64
				5470-5725	4.09	4.75	3.0	0.66
				5725-5850	4.17	4.84	3.0	0.67
				5925-6425	4.34	5.03	3.0	0.69
				6425-6525	4.21	4.91	3.0	0.70
				6525-6875	4.29	5.01	3.0	0.72
(P/N: 0JG1N) Aux Antenna	Wistron	PIFA	Connector P/N: 20632-001R-37(IPEX) 50 ohm Coaxial length: 315.6mm diameter: 1.37mm	2400-2483.5	1.57	2.36	3.0	0.79
				5150-5250	2.42	3.61	3.0	1.19
				5250-5350	2.15	3.35	3.0	1.20
				5470-5725	4.01	5.25	3.0	1.24
				5725-5850	4.01	5.27	3.0	1.26
				5925-6425	4.66	5.95	3.0	1.29
				6425-6525	4.20	5.52	3.0	1.32
				6525-6875	4.07	5.41	3.0	1.34
	6875-7125	4.07	5.45	3.0	1.38			

- 3D Antenna Peak Gain required being test in system basis.

Section 2. Dimensioned Photos and Drawings of Antennas

Include the dimensioned photo and drawing of Main antenna here.

Main Antenna Drawing:

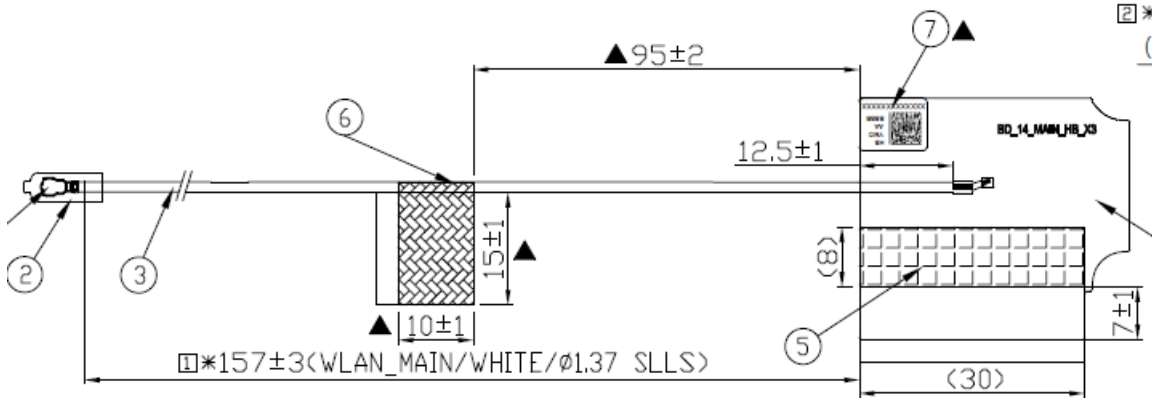

Main Antenna Photo (Front/Back):

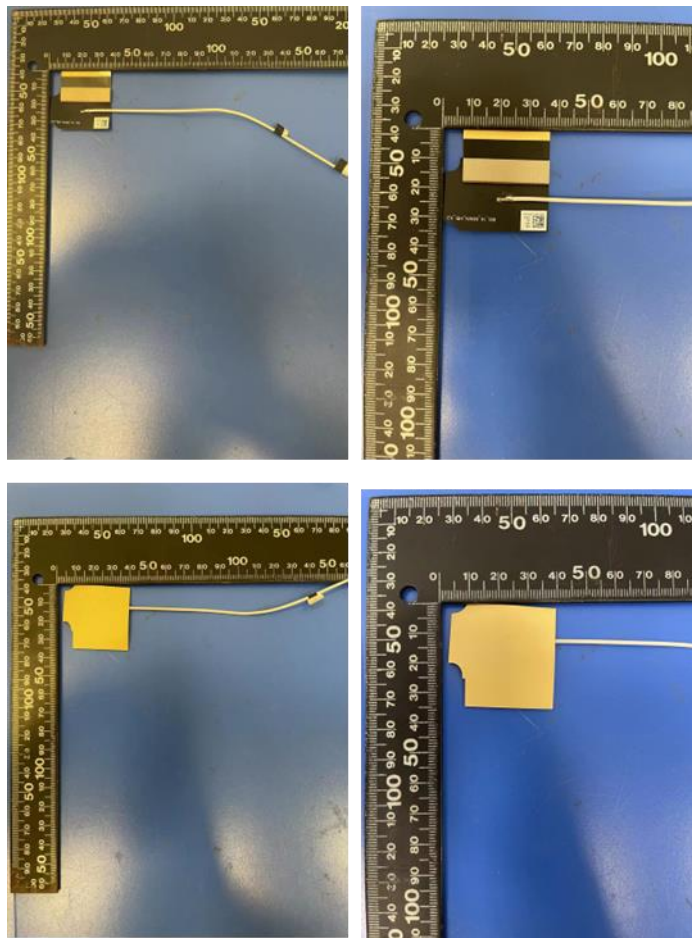

Note: antenna photo should include L type ruler

Include the dimensioned photo and drawing of Aux antenna here.

Aux Antenna Drawing:

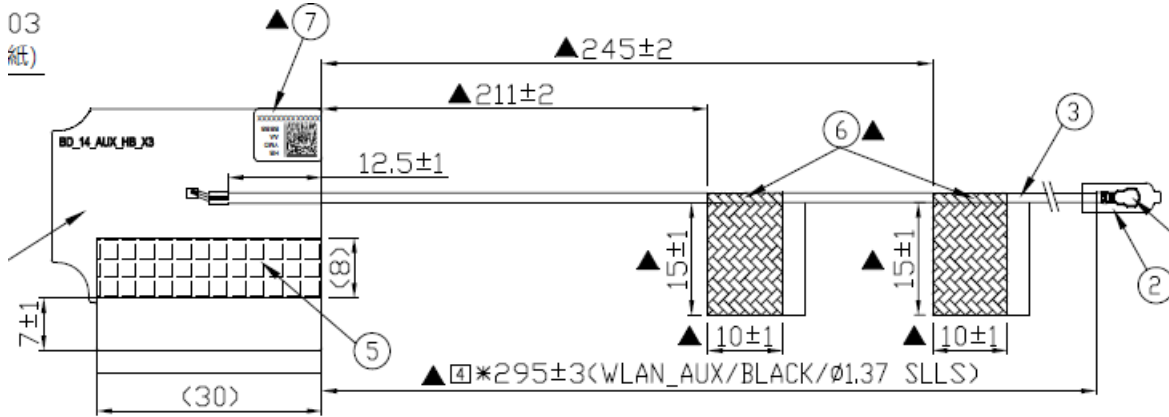

Aux Antenna Photo (Front/Back):

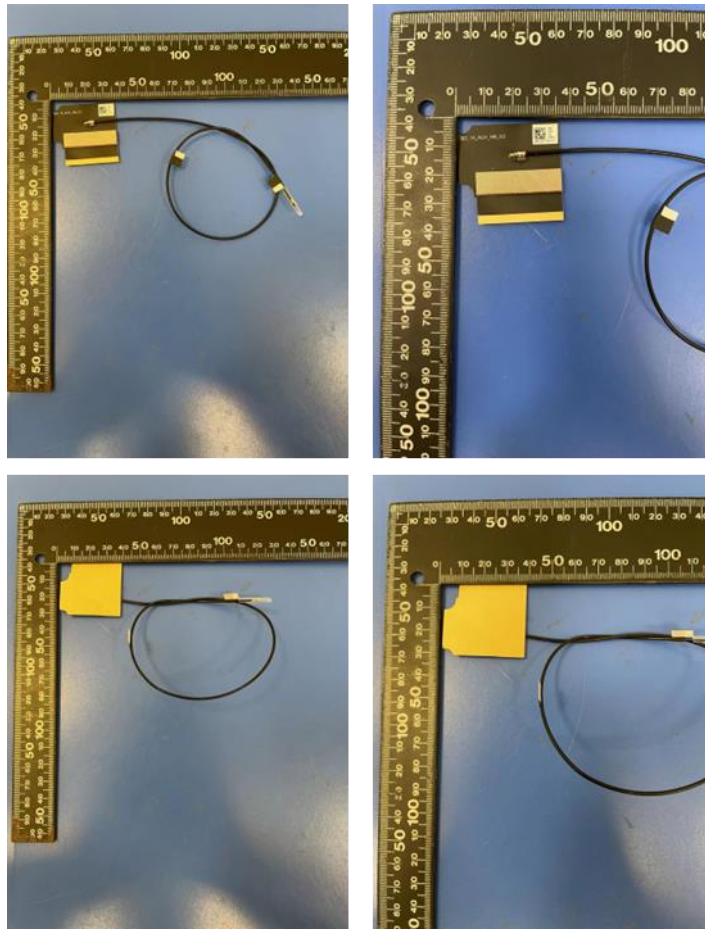

Note: antenna photo should include L type ruler

Section 3. Radiation characteristics of antenna loaded in Host Platform

Main Antenna

Max Antenna 3D Radiation Pattern 2400 – 2483.5 MHz

Frequency (MHz)	Peak Gain w/ Cable Loss (dBi)
2400-2483.5	2.06

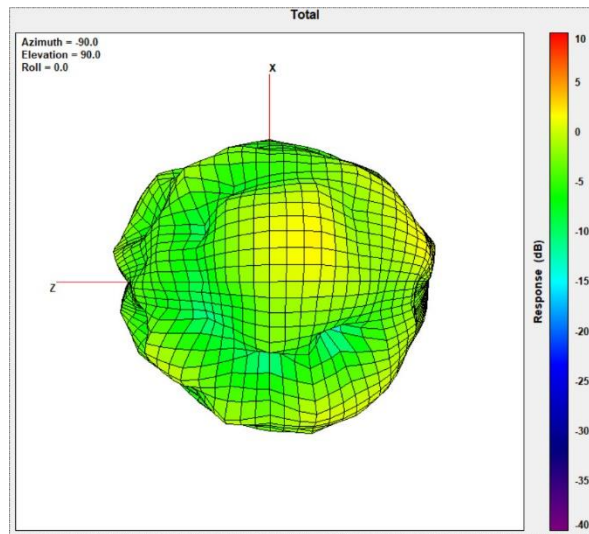

Max Antenna 3D Radiation Pattern 5150-5250 MHz

Frequency (MHz)	Peak Gain w/ Cable Loss (dBi)
5150-5250	2.63

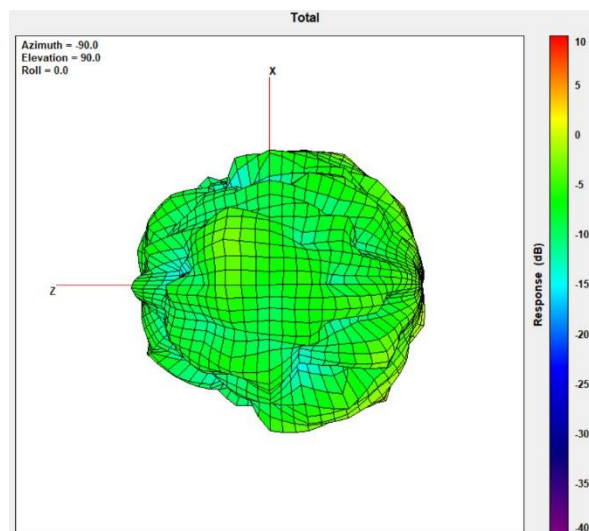

Max Antenna 3D Radiation Pattern 5250-5350 MHz

Frequency (MHz)	Peak Gain w/ Cable Loss (dBi)
5250-5350	2.63

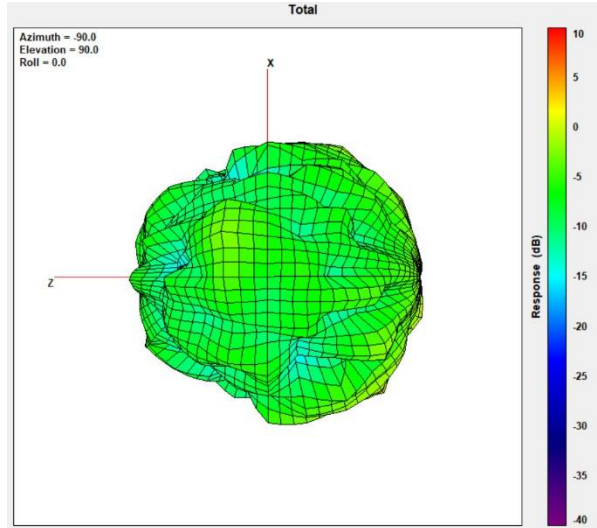

Max Antenna 3D Radiation Pattern 5470-5725 MHz

Frequency (MHz)	Peak Gain w/ Cable Loss (dBi)
5470-5725	4.09

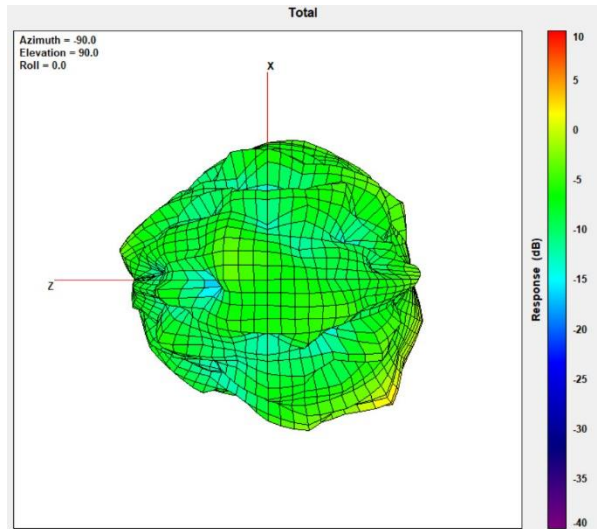

Max Antenna 3D Radiation Pattern 5725-5850 MHz

Frequency (MHz)	Peak Gain w/ Cable Loss (dBi)
5725-5850	4.17

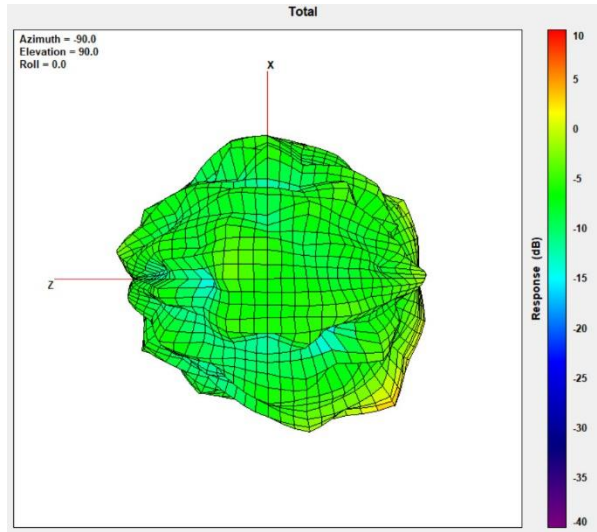

Max Antenna 3D Radiation Pattern 5925-6425 MHz

Frequency (MHz)	Peak Gain w/ Cable Loss (dBi)
5925-6425	4.34

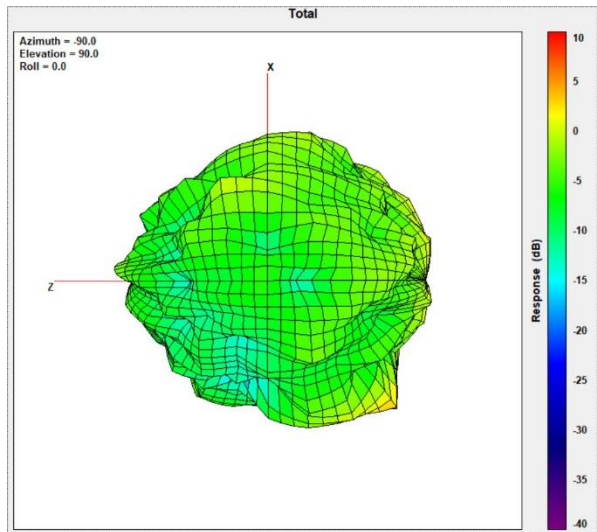

Max Antenna 3D Radiation Pattern 6425-6525 MHz

Frequency (MHz)	Peak Gain w/ Cable Loss (dBi)
6425-6525	4.21

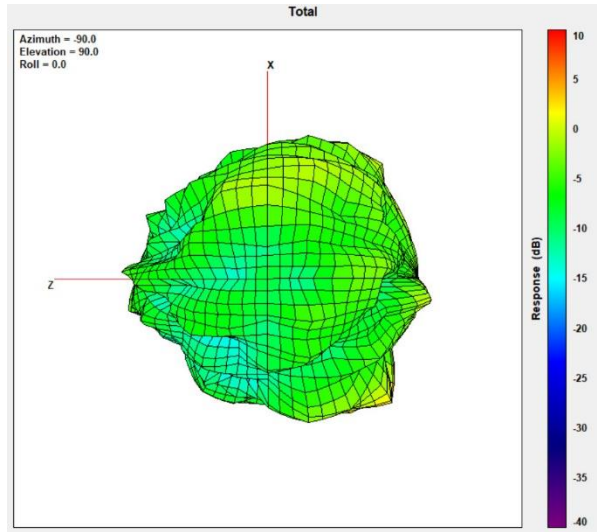

Max Antenna 3D Radiation Pattern 6525-6875 MHz

Frequency (MHz)	Peak Gain w/ Cable Loss (dBi)
6525-6875	4.29

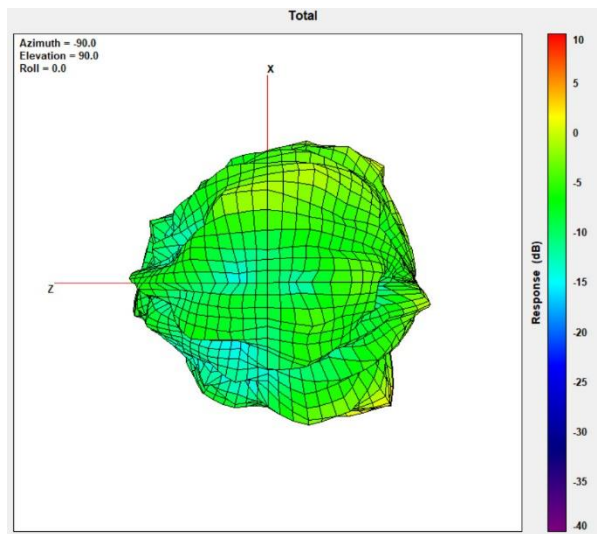

Max Antenna 3D Radiation Pattern 6875-7125 MHz

Frequency (MHz)	Peak Gain w/ Cable Loss (dBi)
6875-7125	4.03

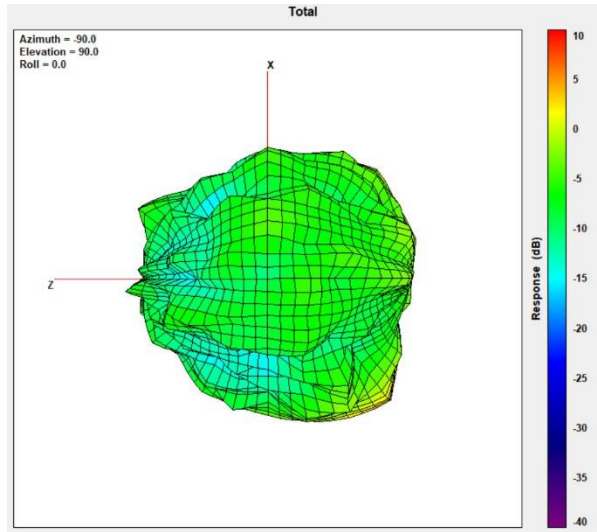

Auxiliary Antenna

Max Antenna 3D Radiation Pattern 2400 – 2483.5 MHz

Frequency (MHz)	Peak Gain w/ Cable Loss (dBi)
2400-2483.5	1.57

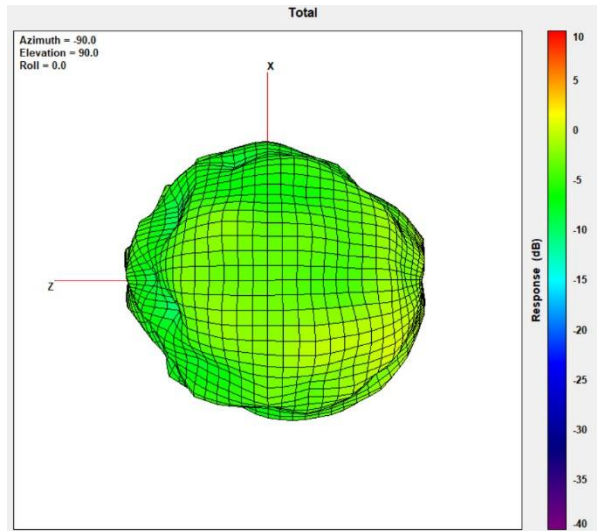

Max Antenna 3D Radiation Pattern 5150-5250 MHz

Frequency (MHz)	Peak Gain w/ Cable Loss (dBi)
5150-5250	2.42

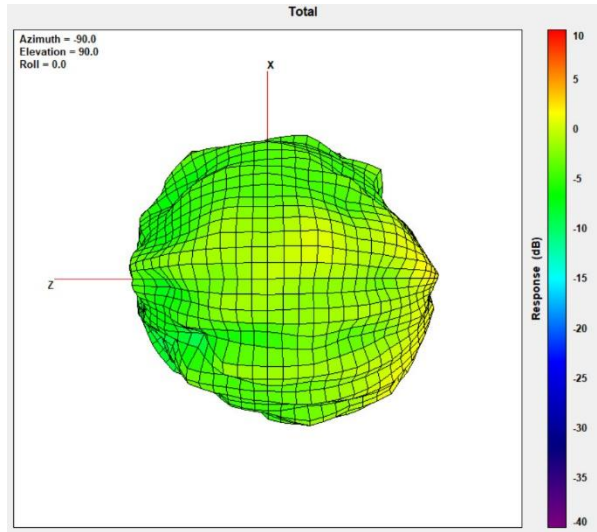

Max Antenna 3D Radiation Pattern 5250-5350 MHz

Frequency (MHz)	Peak Gain w/ Cable Loss (dBi)
5250-5350	2.15

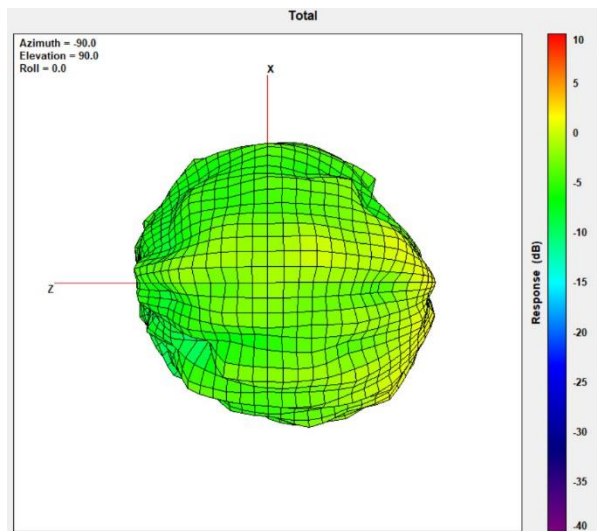

Max Antenna 3D Radiation Pattern 5470-5725 MHz

Frequency (MHz)	Peak Gain w/ Cable Loss (dBi)
5470-5725	4.01

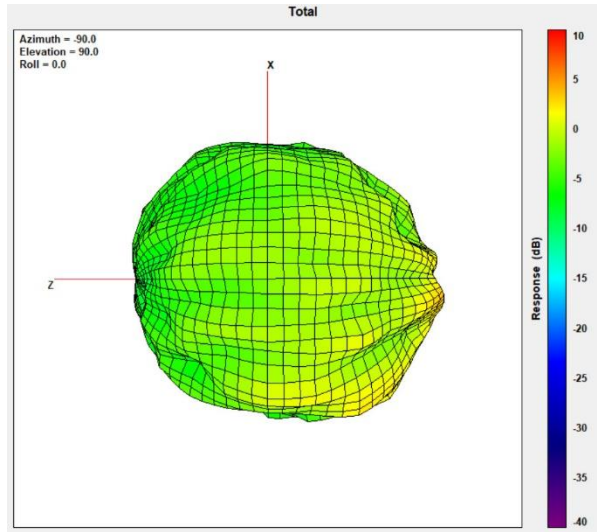

Max Antenna 3D Radiation Pattern 5725-5850 MHz

Frequency (MHz)	Peak Gain w/ Cable Loss (dBi)
5725-5850	4.01

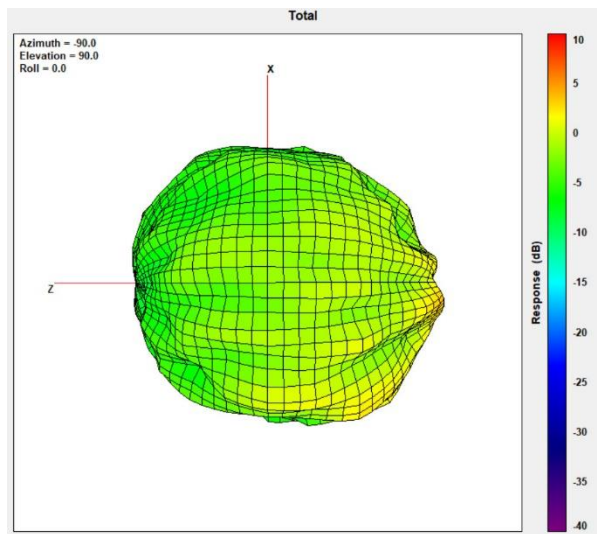

Max Antenna 3D Radiation Pattern 5925-6425 MHz

Frequency (MHz)	Peak Gain w/ Cable Loss (dBi)
5925-6425	4.66

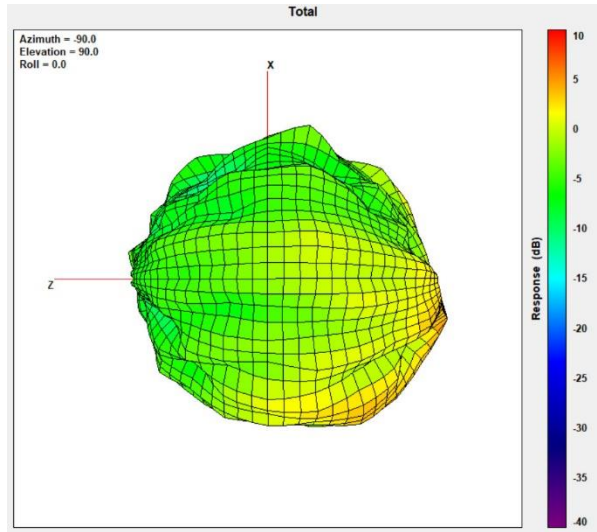

Max Antenna 3D Radiation Pattern 6425-6525 MHz

Frequency (MHz)	Peak Gain w/ Cable Loss (dBi)
6425-6525	4.20

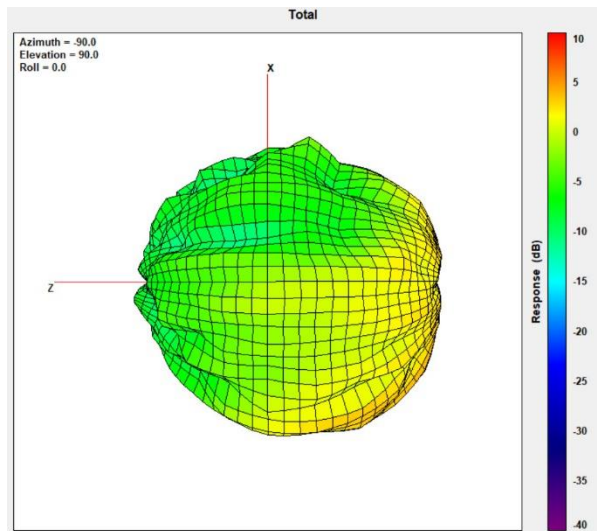

Max Antenna 3D Radiation Pattern 6525-6875 MHz

Frequency (MHz)	Peak Gain w/ Cable Loss (dBi)
6525-6875	4.07

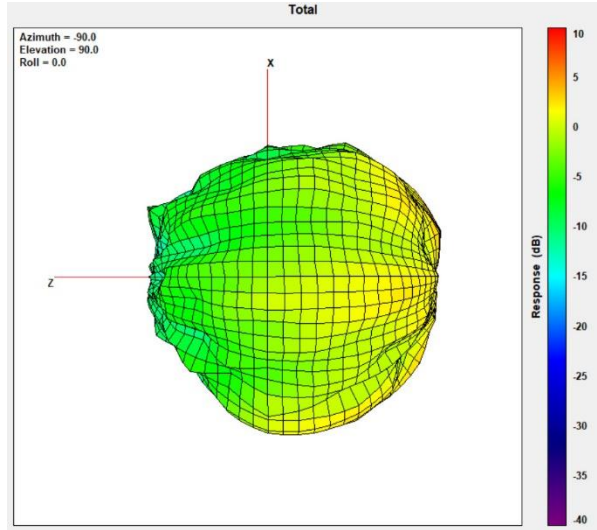

Max Antenna 3D Radiation Pattern 6875-7125 MHz

Frequency (MHz)	Peak Gain w/ Cable Loss (dBi)
6875-7125	4.07

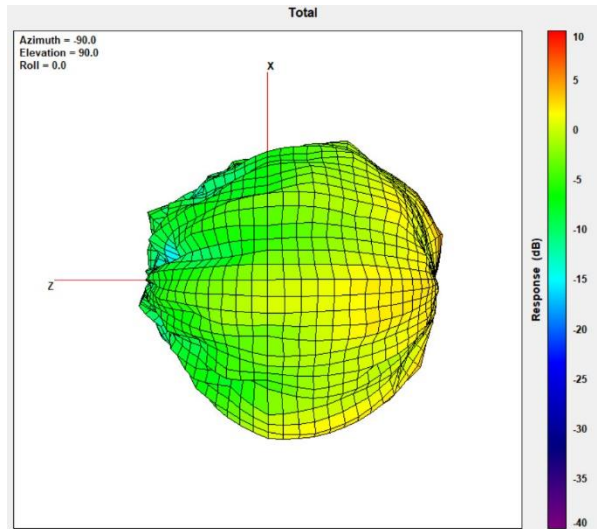

Section 4. Antenna Host Platform Location Information

Include a **dimensioned photo(s) or dimensioned drawing(s)** of Main and Aux antenna placements (measurements are not required for receive-only antenna).

Any antenna that transmits must show dimensions to bottom of laptop. Provide a description of the materials that are used for supporting or surrounding transmit antennas; for example, non-conductive plastics vs. conductive coated plastic or metallic materials.

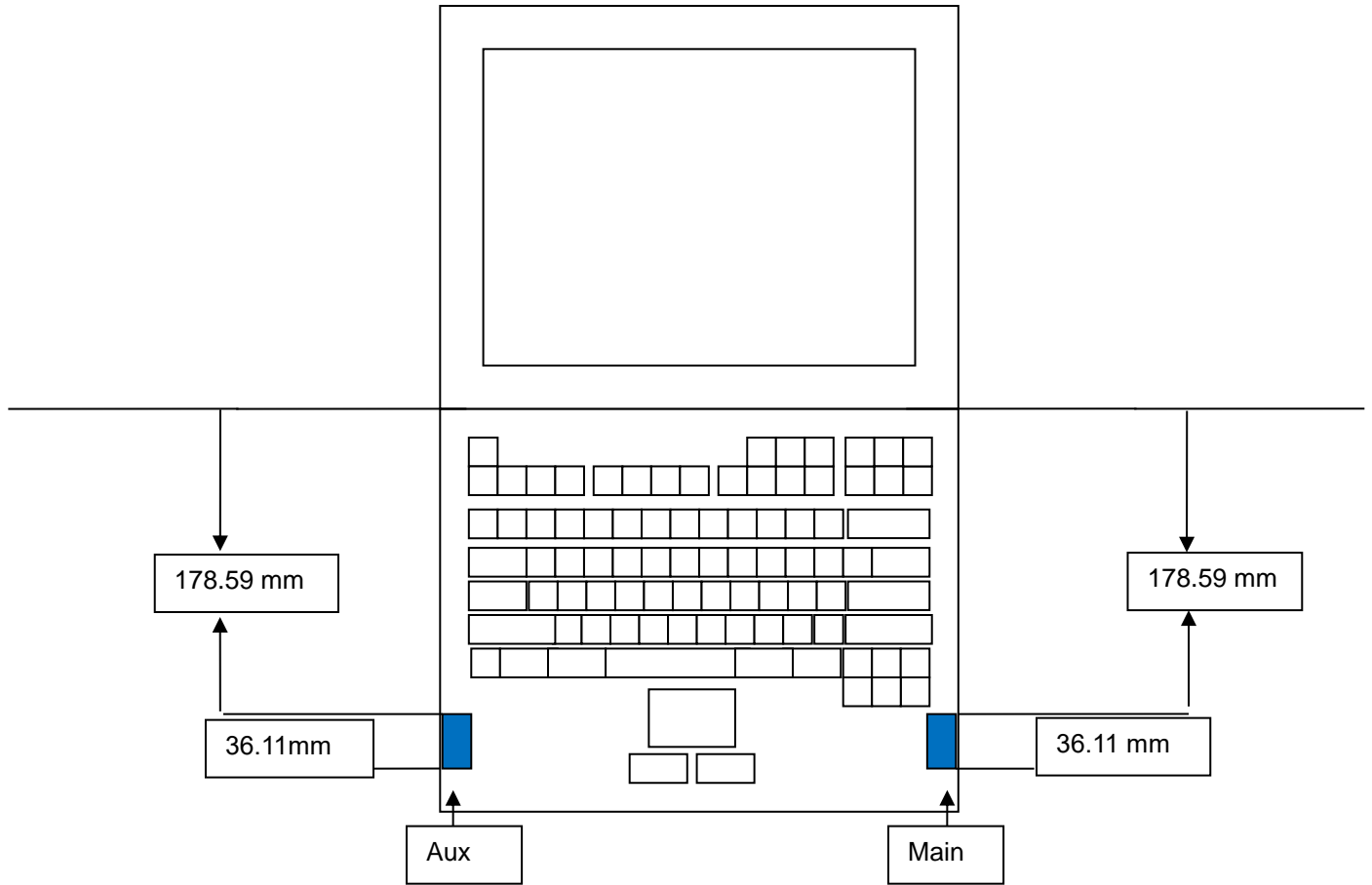

Section 5. Antenna dimensional information for SAR evaluation

Include a **dimensioned photo(s) or dimensioned drawing(s)** showing the distance (mm) between the transmit antennas and the user. For notebook/laptop hosts show lapheld position (example below). For tablet hosts show all orientations including lapheld, primary & secondary portrait, primary & secondary landscape positions. Include a description of any proximity sensors or power throttling implementations that limit or exclude use of any host orientation.

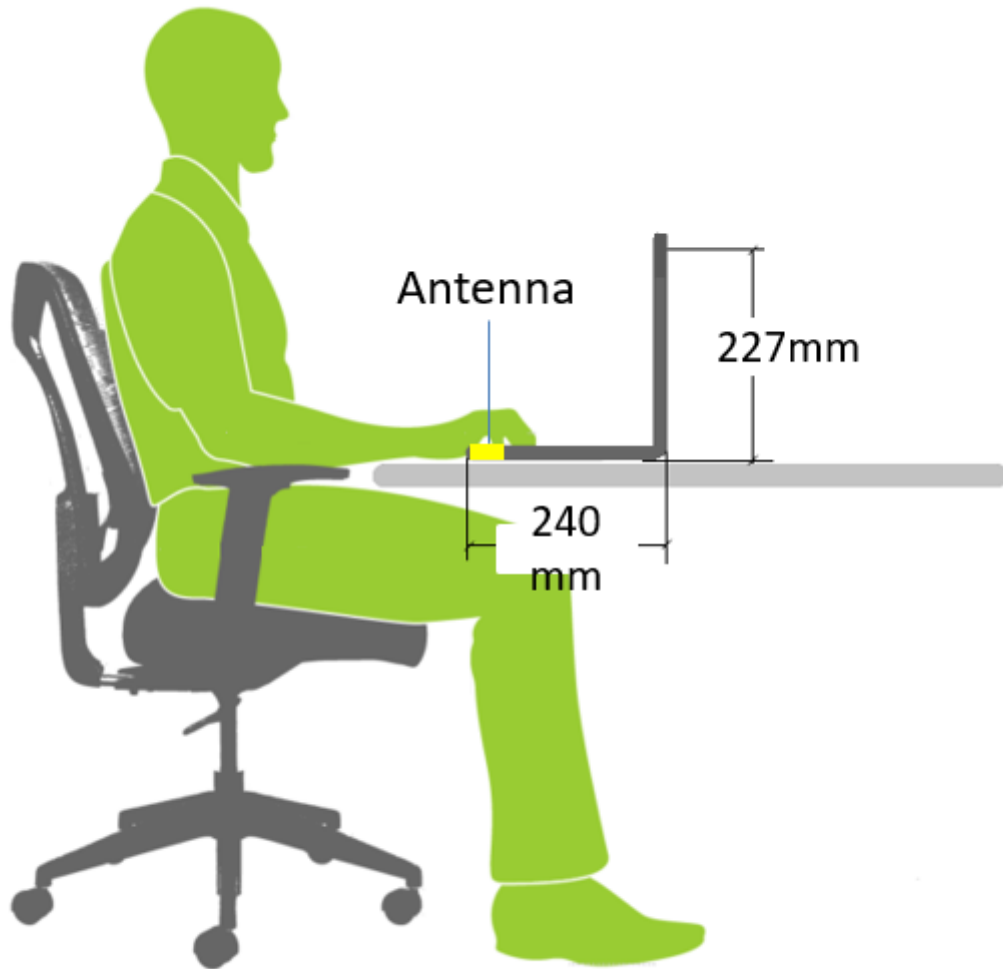

Section 6. Diagram Example of Co-Location Antenna Separation

Include a **dimensioned photo or dimensioned drawing** showing the distance (mm) between **all WLAN transmit antennas** and other co-located radiator transmit antenna such as Bluetooth, WWAN,..

(Note: Due to the evolving rules regarding co-location, each platform will need to be reviewed on a case by case basis)

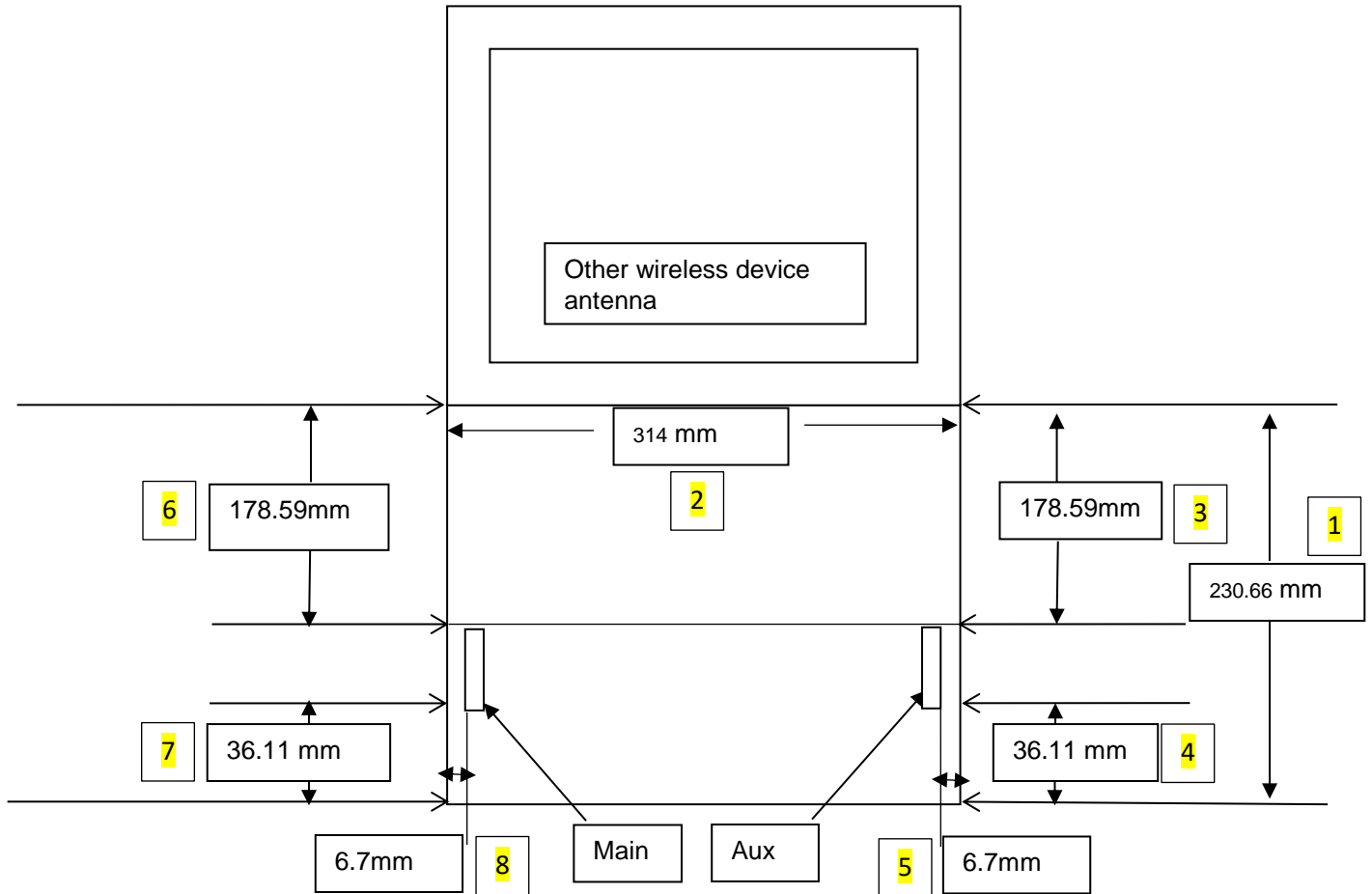

Dimension (mm)	1	2	3	4	5	6	7	8
	230.66	314	178.59	36.11	6.7	178.59	36.11	6.7