

*FCC PART 15, SUBPART B and SUBPART E
TEST REPORT*

for

**INTEL MINI PCI TYPE 3A802.11 ABG
WIRELESS LAN ADAPTER
FOR USE IN THE DELL LAPTOP AGENCY #: PP17L**

MODEL: WM3A2915ABG

Prepared for

**DELL COMPUTER CORPORATION
ONE DELL WAY
ROUND ROCK, TEXAS 78682**

Prepared by: _____

KYLE FUJIMOTO

Approved by: _____

MICHAEL CHRISTENSEN

**COMPATIBLE ELECTRONICS INC.
114 OLINDA DRIVE
BREA, CALIFORNIA 92823
(714) 579-0500**

DATE: APRIL 7, 2005

	REPORT BODY	APPENDICES					TOTAL
		<i>A</i>	<i>B</i>	<i>C</i>	<i>D</i>	<i>E</i>	
PAGES	21	2	2	2	18	72	117

This report shall not be reproduced except in full, without the written approval of Compatible Electronics.

TABLE OF CONTENTS

Section / Title	PAGE
GENERAL REPORT SUMMARY	4
SUMMARY OF TEST RESULTS	5
1. PURPOSE	6
2. ADMINISTRATIVE DATA	7
2.1 Location of Testing	7
2.2 Traceability Statement	7
2.3 Cognizant Personnel	7
2.4 Date Test Sample was Received	7
2.5 Disposition of the Test Sample	7
2.6 Abbreviations and Acronyms	7
3. APPLICABLE DOCUMENTS	8
4. DESCRIPTION OF TEST CONFIGURATION	9
4.1 Description of Test Configuration - EMI	9
4.1.1 Cable Construction and Termination	10
5. LISTS OF EUT, ACCESSORIES AND TEST EQUIPMENT	11
5.1 EUT and Accessory List	11
5.2 EMI Test Equipment for Brea Facility – Part 1	12
5.3 EMI Test Equipment for Brea Facility – Part 2	13
6. TEST SITE DESCRIPTION	14
6.1 Test Facility Description	14
6.2 EUT Mounting, Bonding and Grounding	14
7. CHARACTERISTICS OF THE TRANSMITTER	15
7.1 Antenna Gain	15
8. TEST PROCEDURES	16
8.1 RF Emissions	16
8.1.1 Conducted Emissions Test	16
8.1.2 Radiated Emissions (Spurious and Harmonics) Test	17
8.2 Emission Bandwidth – 20 and 26 dB for UNII Devices	19
8.3 Peak Output Power for UNII Devices	19
8.4 Peak Power Spectral Density for UNII Devices	19
8.5 Peak Excursion for UNII Devices	20
8.6 RF Band Edges	20
9. CONCLUSIONS	21

LIST OF APPENDICES

APPENDIX	TITLE
A	Laboratory Recognitions
B	Modifications to the EUT
C	Additional Models Covered Under This Report
D	Diagrams, Charts, and Photos <ul style="list-style-type: none">• Test Setup Diagrams• Radiated Emissions Photos• Antenna and Effective Gain Factors
E	Data Sheets

LIST OF FIGURES

FIGURE	TITLE
1	Conducted Emissions Test Setup
2	Plot Map and Layout of 3 Meter Radiated Site

GENERAL REPORT SUMMARY

This electromagnetic emission test report is generated by Compatible Electronics Inc., which is an independent testing and consulting firm. The test report is based on testing performed by Compatible Electronics personnel according to the measurement procedures described in the test specifications given below and in the "Test Procedures" section of this report.

The measurement data and conclusions appearing herein relate only to the sample tested and this report may not be reproduced without the written permission of Compatible Electronics, unless done so in full.

This report must not be used to claim product endorsement by NVLAP, NIST, or any other agency of the U.S. Government.

Device Tested: Intel Mini PCI Type 3A 802.11 ABG Wireless LAN Adapter
for use in the Dell Laptop Agency Series Number: PP17L
Model: WM3A2915ABG
S/N: N/A

Product Description: The product is a wireless Mini PCI card used for the Dell Computer Corporation Laptop Agency Series Number: PP17L.

Modifications: The EUT was not modified during the testing.

Manufacturer: Dell Computer Corporation
One Dell Way
Round Rock, Texas 78682

Test Dates: March 14 and 15, 2005

Test Specifications: EMI requirements
Limits: CFR Title 47, Part 15, Subpart B, **Class B**; and CFR Title 47, Part 15, Subpart E

Test Procedure: ANSI C63.4: 2003

Test Deviations: The test procedure was not deviated from during the testing.

SUMMARY OF TEST RESULTS

TEST	DESCRIPTION	RESULTS
1	Conducted RF Emissions, 150 kHz – 30 MHz	Complies with the with the Class B limits of CFR Title 47, Part 15, Subpart B and the limits of CFR Title 47, Part 15, Subpart E
2	Spurious Radiated RF Emissions, 30 MHz – 1000 MHz	Complies with the Class B limits of CFR Title 47, Part 15, Subpart B and the limits of CFR Title 47, Part 15, Subpart E
3	Spurious Radiated RF Emissions, 10 kHz – 30 MHz and 1000 MHz – 40000 MHz	Complies with the Class B limits of CFR Title 47, Part 15, Subpart B; and the limits of CFR Title 47, Part 15, Subpart E
4	Fundamental and Emissions produced by the intentional radiator in non-restricted bands, 10 kHz – 40 GHz	Complies with the limits of CFR Title 47, Part 15, Subpart E
5	Emissions produced by the intentional radiator in restricted bands, 10 kHz – 40 GHz	Complies with the Class B limits of CFR Title 47, Part 15, Subpart B; and the limits of CFR Title 47, Part 15, Subpart E
6	Emission Bandwidth – 26 dB for UNII devices	Complies with the requirements of CFR Title 47, Part 15, Subpart E, section 15.407 (a)(1) and (a)(2)
7	Peak Power for UNII devices	Complies with the requirements of CFR Title 47, Part 15, Subpart E, section 15.407 (a)(1) and (a)(2)
8	Peak Power Spectral Density for UNII devices	Complies with the requirements of CFR Title 47, Part 15, Subpart E, section 15.407 (a)(1) and (a)(2)
9	Peak Excursion for UNII devices	Complies with the requirements of CFR Title 47, Part 15, Subpart E, section 15.407 (a)(6)
10	As the device operates in the 5.15 – 5.25 GHz band, the antenna must be integral to the device.	The antenna is integral to the laptop computer.

1. PURPOSE

This document is a qualification test report based on the Electromagnetic Interference (EMI) tests performed on the Intel Mini PCI Type 3A 802.11 ABG Wireless LAN Adapter (for use in the Dell Laptop Agency Series Number: PP17L) Model: WM3A2915ABG. The EMI measurements were performed according to the measurement procedure described in ANSI C63.4: 2003. The tests were performed in order to determine whether the electromagnetic emissions from the equipment under test, referred to as EUT hereafter, are within the Class B specification limits defined by CFR Title 47, Part 15, Subpart B; and Subpart E.

Note: For the unintentional radiator portion of the test for radiated emissions from 30 MHz to 1000 MHz, the EUT was within the **Class B** specification limits defined in CFR Title 47, Part 15, Subpart B.

Note: The 5.15–5.25 GHz and 5.25–5.35 GHz bands are applicable to this report; other bands of operation (2400 MHz to 2483.5 MHz and 5725 MHz to 5850 MHz) are documented in the Compatible Electronics, Inc. report number **B50326D4**.

2. ADMINISTRATIVE DATA

2.1 Location of Testing

The EMI tests of the testing described herein were performed at the test facility of Compatible Electronics at the following locations

1) 114 Olinda Drive, Brea, California 92823

2.2 Traceability Statement

The calibration certificates of all test equipment used during the test are on file at the location of the test. The calibration is traceable to the National Institute of Standards and Technology (NIST).

2.3 Cognizant Personnel

Dell Computer Corporation

Jason Limoges Regulatory Engineer

Compatible Electronics, Inc.

Benigno Chavez Test Engineer
Arnold Gaffud Sr. Test Engineer
Kyle Fujimoto Test Engineer
Michael Christensen Lab Manager

2.4 Date Test Sample was Received

The test sample was received on March 7, 2005.

2.5 Disposition of the Test Sample

The sample has not been returned to Dell Computer Corporation as of April 7, 2005.

2.6 Abbreviations and Acronyms

The following abbreviations and acronyms may be used in this document.

RF	Radio Frequency
EMI	Electromagnetic Interference
EUT	Equipment Under Test
P/N	Part Number
S/N	Serial Number
HP	Hewlett Packard
ITE	Information Technology Equipment
CML	Corrected Meter Limit
LISN	Line Impedance Stabilization Network

3. APPLICABLE DOCUMENTS

The following documents are referenced or used in the preparation of this EMI Test Report.

SPEC	TITLE
FCC Title 47, Part 15 Subpart E	FCC Rules - Radio frequency devices (including digital devices) – Unlicensed National Information Infrastructure Devices
ANSI C63.4 2003	Methods of measurement of radio-noise emissions from low-voltage electrical and electronic equipment in the range of 9 kHz to 40 GHz
FCC Title 47, Part 15 Subpart B	FCC Rules - Radio frequency devices (including digital devices) – Unintentional Radiators

4. DESCRIPTION OF TEST CONFIGURATION

4.1 Description of Test Configuration - EMI

Setup and operation of the equipment under test.

Specifics of the EUT and Peripherals Tested

The Intel Mini PCI Type 3A 802.11ABG Wireless LAN Adapter (for use in the Dell Laptop Agency Series Number: PP17L) Model: WM3A2915ABG was directly connected to the laptop's mini PCI port at the bottom of the laptop. The laptop was also connected to the printer, modem, and AC Adapter via its parallel, modem, and power ports, respectively. The EUT was either continuously transmitting or receiving depending on the test being performed. The commands for the EUT were programmed using the special test software provided.

Note: For all tests, the main antenna port was tested, with the auxiliary antenna port being spot checked to insure the readings were not higher.

The final radiated as well as the conducted data was taken in the mode above. Please see Appendix E for the data sheets.

4.1.1 Cable Construction and Termination

- Cable 1** This is a 1.5 meter braid and foil shielded cable connecting the laptop to the modem. It has a D-9 pin metallic connector at the laptop end and a D-25 pin metallic connector at the modem end. The cable was bundled to a length of 96 centimeters. The shield of the cable was grounded to the chassis via the connectors.
- Cable 2** This is a 1.4 meter braid and foil shielded cable connecting the laptop to the printer. It has a Centronics metallic type connector at the printer end and a D-25 pin metallic connector at the laptop end. The cable was bundled to a length of 75 centimeters. The shield of the cable was grounded to the chassis via the connectors.
- Cable 3** This is a 1.7 meter unshielded cable connecting the laptop to the AC Adapter. It has a 5.5 mm power connector at the laptop end and is hard wired into the laptop. The cable was bundled to a length of 1.1 meters. The cable had a molded ferrite at the laptop end.

5. LISTS OF EUT, ACCESSORIES AND TEST EQUIPMENT

5.1 EUT and Accessory List

EQUIPMENT	MANUFACTURER	MODEL NUMBER	SERIAL NUMBER	FCC ID
Equipment Name				
Intel Mini PCI Type 3A 802.11 ABG Wireless LAN Adapter (EUT)	INTEL CORPORATION	WM3A2915ABG	N/A	E2K5HCKT
EUT Sub-Assemblies				
Main Antenna	PHYCOMP	DELL P/N: DQ601250112	N/A	N/A
Auxiliary Antenna	PHYCOMP	DELL P/N: DQ601250112	N/A	N/A
Host Equipment List				
Laptop	DELL COMPUTER CORPORATION	PP17L	N/A	DoC
Printer	CITIZEN	LSP-10	118439-72	DLK66TLSP-10
Modem	HAYES	231AA	A07031003480	BFJ9D9231AA
AC Adapter for Laptop	DELL COMPUTER CORPORATION	PA-1650-05D	N/A	N/A

5.2 EMI Test Equipment for Brea Facility – Part 1

EQUIPMENT TYPE	MANU-FACTURER	MODEL NUMBER	SERIAL NUMBER	CAL. DATE	CAL. DUE DATE
Radiated Emissions Manual Test – Radiated	Compatible Electronics	N/A	N/A	N/A	N/A
Conducted Emissions Test Program	Compatible Electronics	N/A	N/A	N/A	N/A
Spectrum Analyzer – Main Section	Hewlett Packard	8566B	3638A08768	June 24, 2004	June 24, 2005
Spectrum Analyzer – Display Section	Hewlett Packard	85662A	3701A22262	June 24, 2004	June 24, 2005
Quasi-Peak Adapter	Hewlett Packard	85650A	2811A01363	June 24, 2004	June 24, 2005
Microwave Preamplifier	Com-Power	PA-122	25196	February 3, 2005	February 3, 2006
Biconical Antenna	Com Power	AB-900	15250	March 11, 2005	March 11, 2006
Log Periodic Antenna	Com Power	AL-100	16060	September 27, 2004	Sept. 27, 2005
Computer	Hewlett Packard	D5251A 888	US74458128	N/A	N/A
Monitor	Hewlett Packard	D5258A	DK74889705	N/A	N/A
LISN	Com Power	LI-215	12090	October 26, 2004	Oct. 26, 2005
LISN	Com Power	LI-215	12076	October 26, 2004	Oct. 26, 2005
Transient Limiter	Seaward	252A910	K39-0220	September 20, 2004	Sept. 20, 2005

5.3 EMI Test Equipment for Brea Facility – Part 2

EQUIPMENT TYPE	MANUFACTURER	MODEL NUMBER	SERIAL NUMBER	CAL. DATE	CAL. DUE DATE
EMI Receiver	Rohde & Schwarz	ESIB40	100172	October 28, 2004	Oct. 28, 2005
Loop Antenna	Com-Power	AL-130	17089	September 3, 2004	Sept. 3, 2005
Horn Antenna	Com-Power	AH826	0071957	November 5, 2003	Nov. 5, 2005
Horn Antenna	Antenna Research	MWH-2640/B	1011	November 5, 2003	Nov. 5, 2005
Horn Antenna	Antenna Research	DRG-118/A	1053	January 16, 2004	Jan. 16, 2006
Microwave Preamplifier	Com Power	PA-122	25195	February 25, 2005	Feb. 25, 2006
Microwave Preamplifier	Com Power	PA-840	711013	February 25, 2005	Feb. 25, 2006
RF Peak Power Meter / Analyzer	Boonton Electronics Corp.	4500A-01-30	1282	February 23, 2004	Feb. 23, 2006
Peak Power Sensor	Boonton Electronics Corp.	57318	3723	February 23, 2004	Feb. 23, 2006
RF Attenuator	Weinschel Corporation	2	BJ6396	August 12, 2004	August 12, 2005

6. TEST SITE DESCRIPTION**6.1 Test Facility Description**

Please refer to section 2.1 and 8.1 of this report for EMI test location.

6.2 EUT Mounting, Bonding and Grounding

The EUT was mounted on a 1.0 by 1.5 meter non-conductive table 0.8 meters above the ground plane.

The EUT was not grounded.

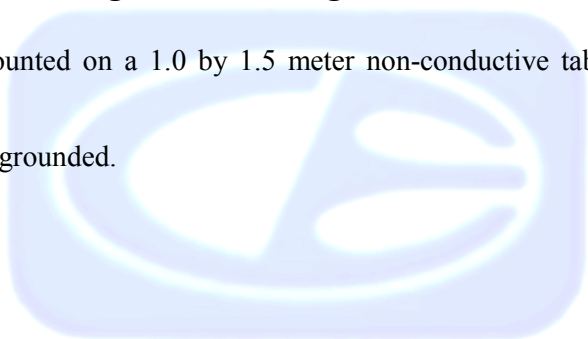

7. CHARACTERISTICS OF THE TRANSMITTER**7.1 Antenna Gain**

The antenna gain is 3.75 dBi.



8. TEST PROCEDURES

The following sections describe the test methods and the specifications for the tests. Test results are also included in this section.

8.1 RF Emissions

8.1.1 Conducted Emissions Test

The spectrum analyzer was used as a measuring meter. The data was collected with the spectrum analyzer in the peak detect mode with the "Max Hold" feature activated. The quasi-peak was used only where indicated in the data sheets. A transient limiter was used for the protection of the spectrum analyzer input stage, and the offset was adjusted accordingly to read the actual data measured. The LISN output was measured using the spectrum analyzer. The output of the second LISN was terminated by a 50 ohm termination. The effective measurement bandwidth used for this test was 9 kHz.

Please see section 6.2 of this report for mounting, bonding and grounding of the EUT. The EUT was powered through the LISN, which was bonded to the ground plane. The LISN power was filtered and the filter was bonded to the ground plane. The EUT was set up with the minimum distances from any conductive surfaces as specified in ANSI C63.4: 2003. The excess power cord was wrapped in a figure eight pattern to form a bundle not exceeding 0.4 meters in length.

The conducted emissions from the EUT were maximized for operating mode as well as cable placement. The final data was collected under program control by the Compatible Electronics conducted emissions software in several overlapping sweeps by running the spectrum analyzer at a minimum scan rate of 10 seconds per octave. The final qualification data is located in Appendix E.

Test Results:

The EUT complies with the limits of CFR Title 47, Part 15, Subpart E for conducted emissions.

8.1.2 Radiated Emissions (Spurious and Harmonics) Test

The spectrum analyzer was used as a measuring meter along with the quasi-peak adapter. Amplifiers were used to increase the sensitivity of the instrument. The Com Power Preamplifier Model: PA-103 was used for frequencies from 30 MHz to 1 GHz, the Com-Power Microwave Preamplifier Model: PA-122 was used for frequencies from 1 GHz to 18 GHz, and the Com Power Microwave Preamplifier Model: PA-840 was used for frequencies from 18 GHz to 40 GHz. The spectrum analyzer was used in the peak detect mode with the "Max Hold" feature activated. In this mode, the spectrum analyzer records the highest measured reading over all the sweeps.

The quasi-peak adapter was used only for those readings which are marked accordingly on the data sheets.

The frequencies above 1 GHz were averaged manually by narrowing the video filter down to 10 Hz and putting the sweep time on AUTO on the EMI Receiver to keep the amplitude reading calibrated.

The measurement bandwidths and transducers used for the radiated emissions test were:

FREQUENCY RANGE	EFFECTIVE MEASUREMENT BANDWIDTH	TRANSDUCER
10 kHz to 150 kHz	200 Hz	Active Loop Antenna
150 kHz to 30 MHz	9 kHz	Active Loop Antenna
30 MHz to 300 MHz	120 kHz	Biconical Antenna
300 MHz to 1 GHz	120 kHz	Log Periodic Antenna
1 GHz to 40 GHz	1 MHz	Horn Antenna

The open field test site of Compatible Electronics, Inc. was used for radiated emission testing. This test site is set up according to ANSI C63.4: 2003. Please see section 6.2 of this report for mounting, bonding and grounding of the EUT. The turntable supporting the EUT is remote controlled using a motor. The turntable permits EUT rotation of 360 degrees in order to maximize emissions. Also, the antenna mast allows height variation of the antenna from 1 meter to 4 meters. Data was collected in the worst case (highest emission) configuration of the EUT by the Radiated Emission Manual Test software. At each reading, the EUT was rotated 360 degrees and the antenna height was varied from 1 to 4 meters (for E field radiated field strength). The gunsight method was used when measuring with the horn antenna in order to ensure accurate results.

Radiated Emissions (Spurious and Harmonics) Test (con't)

The presence of ambient signals was verified by turning the EUT off. In case an ambient signal was detected, the measurement bandwidth was reduced temporarily and verification was made that an additional adjacent peak did not exist. This ensures that the ambient signal does not hide any emissions from the EUT. The EUT was tested at a 3 meter test distance to obtain the final data.

Test Results:

The EUT complies with the **Class B** limits of CFR Title 47, Part 15, Subpart B; and Subpart C, sections 15.205, 15.209, and 15.247 (d). Please see the data sheets located in Appendix E.

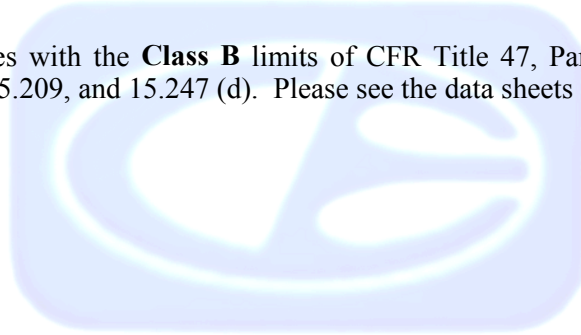

8.2 Emission Bandwidth – 20 and 26 dB for UNII Devices

The transmitter output is connected to the EMI Receiver. The RBW is set to 1% to 3% of the emission bandwidth. The VBW is set greater than the RBW. The sweep time is coupled. The view button was used to capture the emission. The widest width of the emission that is 20 or 26 dB down from the peak of the emission was measured.

Test Results:

The EUT complies with the requirements of CFR Title 47, Part 15, Subpart E, section 15.407 (a)(1) and (a)(2).

8.3 Peak Output Power for UNII Devices

The Peak Output Power was measured using the power meter and power sensor. The EUT was directly connected to the power sensor, which was directly connected to the power meter. The Peak Output Power was then measured

Test Results:

The EUT complies with the requirements of CFR Title 47, Part 15, Subpart E, section 15.407 (a)(1) and (a)(2).

8.4 Peak Power Spectral Density for UNII Devices

The EUT is directly connected to the EMI Receiver.

For FCC: The RBW was set to 1 MHz. The VBW was set greater than the RBW. The video averaging was turned on. The Peak Power Spectral Density was the highest level found across the emission in any 1 MHz band after 100 sweeps of video averaging.

For RSS-210: The RBW and VBW was set to 1 MHz. The video averaging was turned off.

For FCC: The limit is +4 dBm / MHz for the 5150 MHz to 5250 MHz band, and +11 dBm / MHz for the 5250 MHz to 5350 MHz band.

For RSS-210: The limit is +10 dBm / MHz for the 5150 MHz to 5250 MHz band, and +11 dBm / MHz for the 5250 MHz to 5350 MHz band.

Test Results:

The EUT complies with the requirements of CFR Title 47, Part 15, Subpart E, section 15.407 (a)(1) and (a)(2).

8.5 Peak Excursion for UNII Devices

The EUT was directly connected to the EMI Receiver.

The first trace was established using an RBW and VBW of 1 MHz. The second trace was established using an RBW of 1 MHz and a VBW of 30 kHz. The delta marker function was used to determine that the difference between the two traces in any 1 MHz band on any frequency was not greater than 13 dB.

Test Results:

The EUT complies with the requirements of CFR Title 47, Part 15, Subpart E, section 15.407 (a)(6).

8.6 RF Band Edges

The RF band edges were taken at the 5150 MHz and 5350 MHz. The readings taken were also averaged manually by narrowing the video filter down to 10 Hz and putting the sweep time on AUTO on the spectrum analyzer to keep the amplitude reading calibrated. Data sheets are included in Appendix E, which compares the reading from the spectrum analyzer to the spec limit.

Test Results:

The EUT complies with the relevant requirements of FCC Title 47, Part 15, Subpart E. The RF power at the band edges at 5150 MHz and 5350 MHz meet the limits of section FCC Title 47, Part 15, Subpart C, Section 15.209. Please see the data sheets located in Appendix E.

9. CONCLUSIONS

The Intel Mini PCI Type 3A 802.11 ABG Wireless LAN Adapter (for use in the Dell Laptop Agency Series Number: PP17L) Model: WM3A2915ABG meets all of the specification limits defined in FCC Title 47, Part 15, Subpart B and Subpart E.

Note: For the unintentional radiator portion of the test for radiated emissions from 30 MHz to 1000 MHz, the EUT was within the **Class B** specification limits defined in CFR Title 47, Part 15, Subpart B.

Note: The 5.15–5.25 GHz and 5.25–5.35 GHz bands are applicable to this report; other bands of operation (2400 MHz to 2483.5 MHz and 5725 MHz to 5850 MHz) are documented in the Compatible Electronics, Inc. report number **B50326D4**.

APPENDIX A***LABORATORY RECOGNITIONS***

Brea Division
114 Olinda Drive
Brea, CA 92823
(714) 579-0500

Agoura Division
2337 Troutdale Drive
Agoura, CA 91301
(818) 597-0600

Silverado Division
19121 El Toro Road
Silverado, CA 92676
(949) 589-0700

Lake Forest Division
20621 Pascal Way
Lake Forest, CA 92630
(949) 587-0400

LABORATORY RECOGNITIONS

Compatible Electronics has the following agency accreditations:

National Voluntary Laboratory Accreditation Program - Lab Code: 200528-0

Voluntary Control Council for Interference - Registration Numbers: R-983, C-1026, R-984 and C-1027

Bureau of Standards and Metrology Inspection - Reference Number: SL2-IN-E-1031

Conformity Assessment Body for the EMC Directive Under the US/EU MRA Appointed by NIST

Compatible Electronics is recognized or on file with the following agencies:

Federal Communications Commission

Industry Canada

Radio-Frequency Technologies (Competent Body)



APPENDIX B

MODIFICATIONS TO THE EUT

MODIFICATIONS TO THE EUT

The modifications listed below were made to the EUT to pass FCC Subpart B and Subpart E specifications.

All the rework described below was implemented during the test in a method that could be reproduced in all the units by the manufacturer.

No modifications were made to the EUT during the testing.

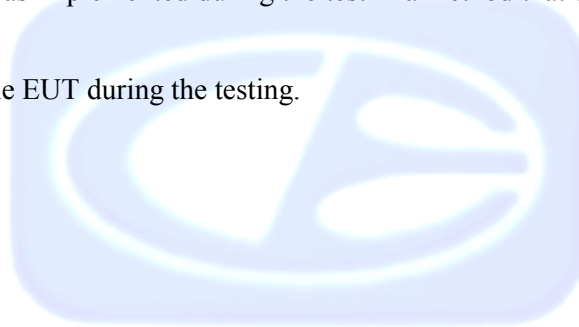



APPENDIX C

***ADDITIONAL MODELS COVERED
UNDER THIS REPORT***

Brea Division
114 Olinda Drive
Brea, CA 92823
(714) 579-0500

Agoura Division
2337 Troutdale Drive
Agoura, CA 91301
(818) 597-0600

Silverado Division
19121 El Toro Road
Silverado, CA 92676
(949) 589-0700

Lake Forest Division
20621 Pascal Way
Lake Forest, CA 92630
(949) 587-0400

ADDITIONAL MODELS COVERED UNDER THIS REPORT

USED FOR THE PRIMARY TEST

Intel Mini PCI Type 3A 802.11 ABG Wireless LAN Adapter
(for use in the Dell Laptop Agency Series Number: PP17L)
Model: WM3A2915ABG
S/N: N/A

There were no additional models covered under this report.



APPENDIX D

DIAGRAMS, CHARTS, AND PHOTOS

FIGURE 1: CONDUCTED EMISSIONS TEST SETUP

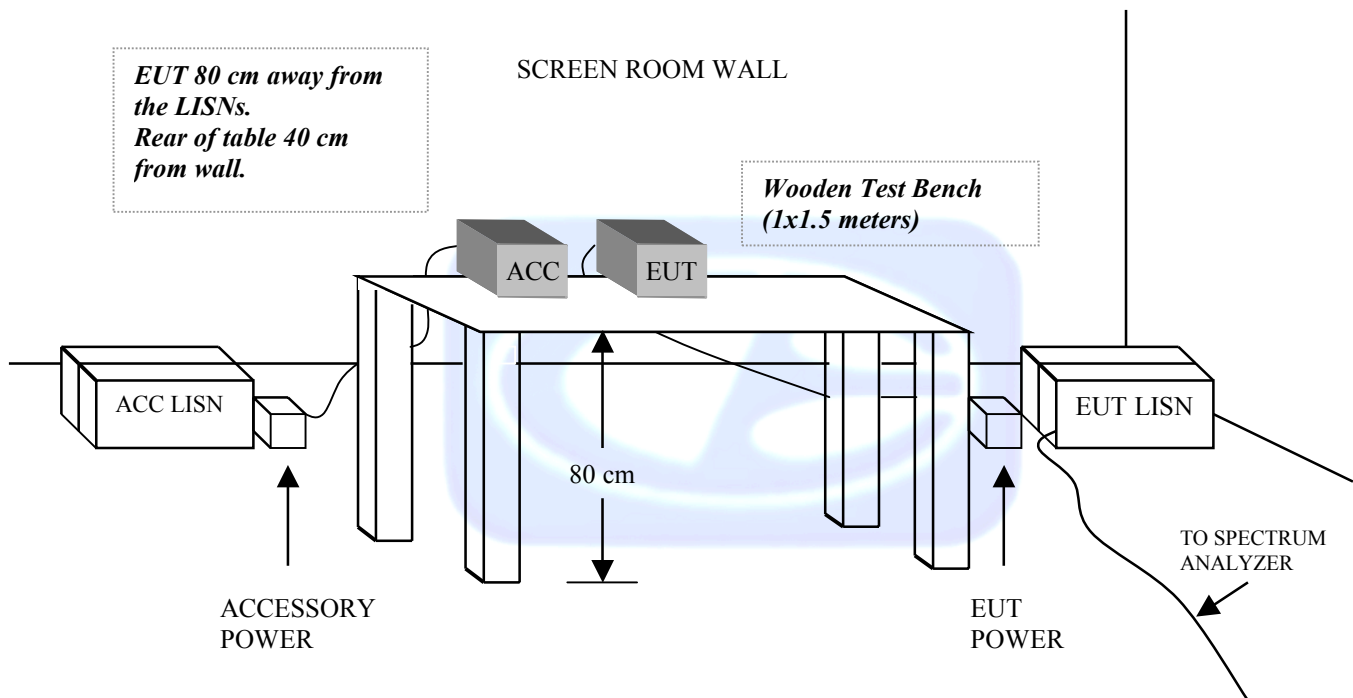
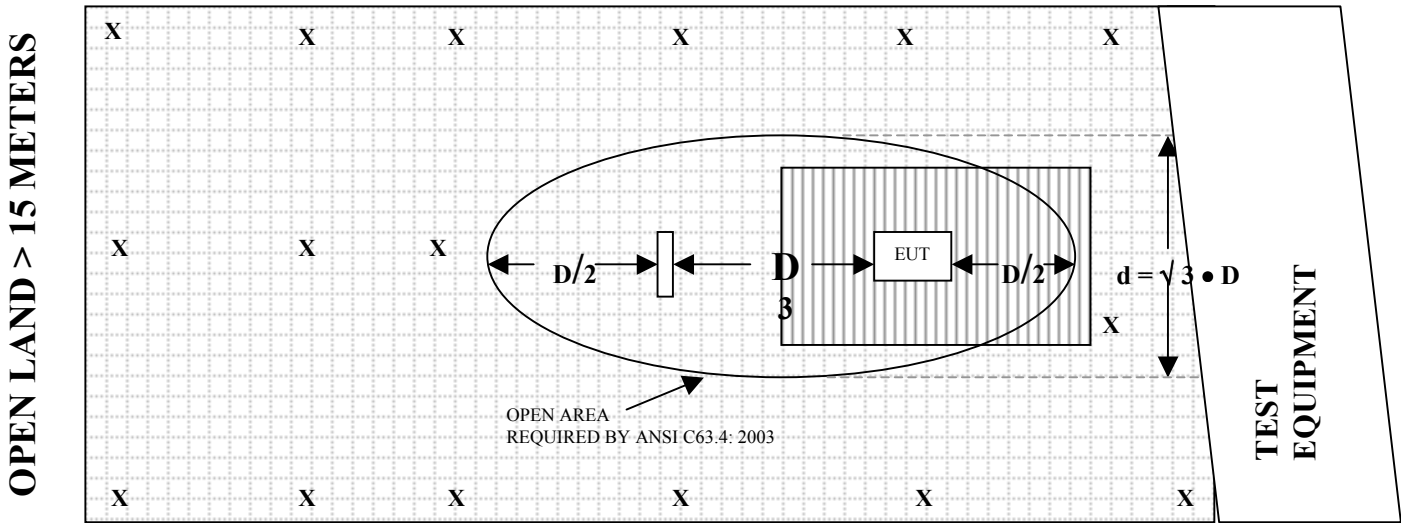

FIGURE 2: PLOT MAP AND LAYOUT OF 3 METER RADIATED SITE

OPEN LAND > 15 METERS



OPEN LAND > 15 METERS

- | | | | |
|----------|--------------------------|--|-----------------|
| X | = GROUND RODS | | = GROUND SCREEN |
| D | = TEST DISTANCE (meters) | | = WOOD COVER |

COM-POWER AB-900**BICONICAL ANTENNA**

S/N: 15250

CALIBRATION DATE: MARCH 11, 2005

FREQUENCY (MHz)	FACTOR (dB)	FREQUENCY (MHz)	FACTOR (dB)
30	10.90	120	13.10
35	10.90	125	12.40
40	10.90	140	11.90
45	10.30	150	11.80
50	11.40	160	13.30
60	10.40	175	15.40
70	7.40	180	14.60
80	6.20	200	15.70
90	8.20	250	16.50
100	10.10	300	19.20

COM-POWER AL-100**LOG PERIODIC ANTENNA**

S/N: 16060

CALIBRATION DATE: SEPTEMBER 27, 2004

FREQUENCY (MHz)	FACTOR (dB)	FREQUENCY (MHz)	FACTOR (dB)
300	12.30	700	19.20
400	14.10	800	21.30
500	15.20	900	21.90
600	15.90	1000	25.20

COM-POWER PA-103**PREAMPLIFIER**

S/N: 1582

CALIBRATION DATE: FEBRUARY 3, 2005

FREQUENCY (MHz)	FACTOR (dB)	FREQUENCY (MHz)	FACTOR (dB)
30	33.2	300	33.0
40	33.0	350	32.8
50	33.1	400	32.8
60	33.0	450	32.8
70	33.2	500	32.5
80	33.2	550	32.5
90	33.1	600	32.4
100	33.2	650	32.4
125	33.1	700	32.3
150	33.0	750	32.2
175	33.0	800	32.2
200	33.0	850	32.4
225	33.0	900	31.8
250	33.0	950	32.3
275	32.9	1000	32.0

COM-POWER PA-122**MICROWAVE PREAMPLIFIER**

S/N: 25195

CALIBRATION DATE: FEBRUARY 25, 2005

FREQUENCY (GHz)	FACTOR (dB)	FREQUENCY (GHz)	FACTOR (dB)
1.0	31.45	6.0	31.35
1.1	31.34	6.5	31.10
1.2	31.29	7.0	30.54
1.3	31.28	7.5	29.72
1.4	31.25	8.0	29.22
1.5	31.21	8.5	28.75
1.6	31.14	9.0	28.67
1.7	31.07	9.5	29.14
1.8	31.12	10.0	30.12
1.9	31.04	11.0	29.30
2.0	31.20	12.0	29.86
2.5	31.56	13.0	30.57
3.0	32.17	14.0	29.90
3.5	32.56	15.0	30.14
4.0	32.51	16.0	31.13
4.5	32.52	17.0	29.97
5.0	32.33	18.0	28.77
5.5	31.60		

COM-POWER PA-840**MICROWAVE PREAMPLIFIER**

S/N: 711013

CALIBRATION DATE: FEBRUARY 25, 2005

FREQUENCY (GHz)	FACTOR (dB)	FREQUENCY (GHz)	FACTOR (dB)
18.0	27.193	29.5	28.341
18.5	26.721	30.0	28.166
19.0	25.938	30.5	28.259
19.5	25.678	31.0	27.227
20.0	25.192	31.5	27.134
20.5	24.643	32.0	27.349
21.0	23.898	32.5	26.701
21.5	24.261	33.0	26.965
22.0	24.544	33.5	27.326
22.5	24.984	34.0	26.536
23.0	25.008	34.5	26.753
23.5	25.268	35.0	26.133
24.0	25.697	35.5	25.759
24.5	26.304	36.0	25.538
25.0	26.716	36.5	26.126
25.5	26.939	37.0	26.719
26.0	27.009	37.5	26.713
26.5	27.299	38.0	26.035
27.0	27.931	38.5	24.438
27.5	27.516	39.0	24.013
28.0	27.402	39.5	23.474
28.5	27.457	40.0	24.467
29.0	27.926		

ANTENNA RESEARCH DRG-118/A**HORN ANTENNA**

S/N: 1053

CALIBRATION DATE: JANUARY 16, 2004

FREQUENCY (GHz)	FACTOR (dB)	FREQUENCY (GHz)	FACTOR (dB)
1.0	24.4	10.0	38.7
1.5	25.2	10.5	39.0
2.0	28.2	11.0	38.9
2.5	28.5	11.5	41.3
3.0	30.1	12.0	40.5
3.5	31.0	12.5	40.0
4.0	31.2	13.0	40.2
4.5	31.9	13.5	40.5
5.0	33.2	14.0	41.6
5.5	33.7	14.5	44.8
6.0	34.3	15.0	41.4
6.5	35.0	15.5	39.2
7.0	36.7	16.0	39.4
7.5	37.3	16.5	40.9
8.0	37.1	17.0	42.6
8.5	37.3	17.5	45.1
9.0	37.7	18.0	41.7
9.5	38.6		

COM-POWER AL-130**LOOP ANTENNA**

S/N: 17089

CALIBRATION DATE: SEPTEMBER 3, 2004

FREQUENCY (MHz)	MAGNETIC (dB/m)	ELECTRIC (dB/m)
0.009	-40.8	10.7
0.01	-40.9	10.6
0.02	-41.8	9.7
0.05	-42.0	9.5
0.07	-41.5	10.0
0.1	-41.7	9.8
0.2	-44.1	7.4
0.3	-41.6	9.9
0.5	-41.5	10.0
0.7	-41.4	10.1
1	-41.0	10.5
2	-40.6	10.9
3	-40.8	10.7
4	-41.0	10.5
5	-40.4	11.1
10	-40.7	10.8
15	-41.6	9.9
20	-41.3	10.2
25	-43.0	8.5
30	-42.6	8.9

COM-POWER AH826**HORN ANTENNA**

S/N: 0071957

CALIBRATION DATE: NOVEMBER 05, 2003

FREQUENCY (GHz)	FACTOR (dB)	FREQUENCY (GHz)	FACTOR (dB)
18.0	33.3	22.5	32.9
18.5	32.9	23.0	33.0
19.0	32.7	23.5	33.6
19.5	32.6	24.0	33.6
20.0	32.7	24.5	33.5
20.5	33.0	25.0	33.5
21.0	33.0	25.5	33.7
21.5	33.2	26.0	34.1
22.0	32.9	26.5	34.5

ANTENNA RESEARCH MWH-2640/B**HORN ANTENNA**

S/N: 1011

CALIBRATION DATE: NOVEMBER 05, 2003

FREQUENCY (GHz)	FACTOR (dB)	FREQUENCY (GHz)	FACTOR (dB)
26.5	36.0	33.5	36.0
27.0	36.0	34.0	36.8
27.5	35.6	34.5	37.3
28.0	35.9	35.0	37.7
28.5	35.8	35.5	37.8
29.0	36.0	36.0	38.2
29.5	35.9	36.5	38.3
30.0	36.4	37.0	38.2
30.5	36.4	37.5	38.6
31.0	36.8	38.0	38.6
31.5	36.5	38.5	39.1
32.0	36.5	39.0	38.8
32.5	36.2	39.5	39.0
33.0	36.4	40.0	39.5



FRONT VIEW

DELL COMPUTER CORPORATION
INTEL MINI PCI TYPE 3A 802.11 ABG WIRELESS LAN ADAPTER
FOR USE IN THE DELL LAPTOP AGENCY SERIES NUMBER: PP17L
MODEL: WM3A2915ABG
FCC SUBPART B AND E – RADIATED EMISSIONS

**PHOTOGRAPH SHOWING THE EUT CONFIGURATION
FOR MAXIMUM EMISSIONS**

Brea Division
114 Olinda Drive
Brea, CA 92823
(714) 579-0500

Agoura Division
2337 Troutdale Drive
Agoura, CA 91301
(818) 597-0600

Silverado Division
19121 El Toro Road
Silverado, CA 92676
(949) 589-0700

Lake Forest Division
20621 Pascal Way
Lake Forest, CA 92630
(949) 587-0400



REAR VIEW

DELL COMPUTER CORPORATION
INTEL MINI PCI TYPE 3A 802.11 ABG WIRELESS LAN ADAPTER
FOR USE IN THE DELL LAPTOP AGENCY SERIES NUMBER: PP17L
MODEL: WM3A2915ABG
FCC SUBPART B AND E – RADIATED EMISSIONS

**PHOTOGRAPH SHOWING THE EUT CONFIGURATION
FOR MAXIMUM EMISSIONS**

Brea Division
114 Olinda Drive
Brea, CA 92823
(714) 579-0500

Agoura Division
2337 Troutdale Drive
Agoura, CA 91301
(818) 597-0600

Silverado Division
19121 El Toro Road
Silverado, CA 92676
(949) 589-0700

Lake Forest Division
20621 Pascal Way
Lake Forest, CA 92630
(949) 587-0400



FRONT VIEW

DELL COMPUTER CORPORATION
INTEL MINI PCI TYPE 3A 802.11 ABG WIRELESS LAN ADAPTER
FOR USE IN THE DELL LAPTOP AGENCY SERIES NUMBER: PP17L
MODEL: WM3A2915ABG
FCC SUBPART B AND E – RADIATED EMISSIONS

**PHOTOGRAPH SHOWING THE EUT CONFIGURATION
FOR MAXIMUM EMISSIONS**

Brea Division
114 Olinda Drive
Brea, CA 92823
(714) 579-0500

Agoura Division
2337 Troutdale Drive
Agoura, CA 91301
(818) 597-0600

Silverado Division
19121 El Toro Road
Silverado, CA 92676
(949) 589-0700

Lake Forest Division
20621 Pascal Way
Lake Forest, CA 92630
(949) 587-0400

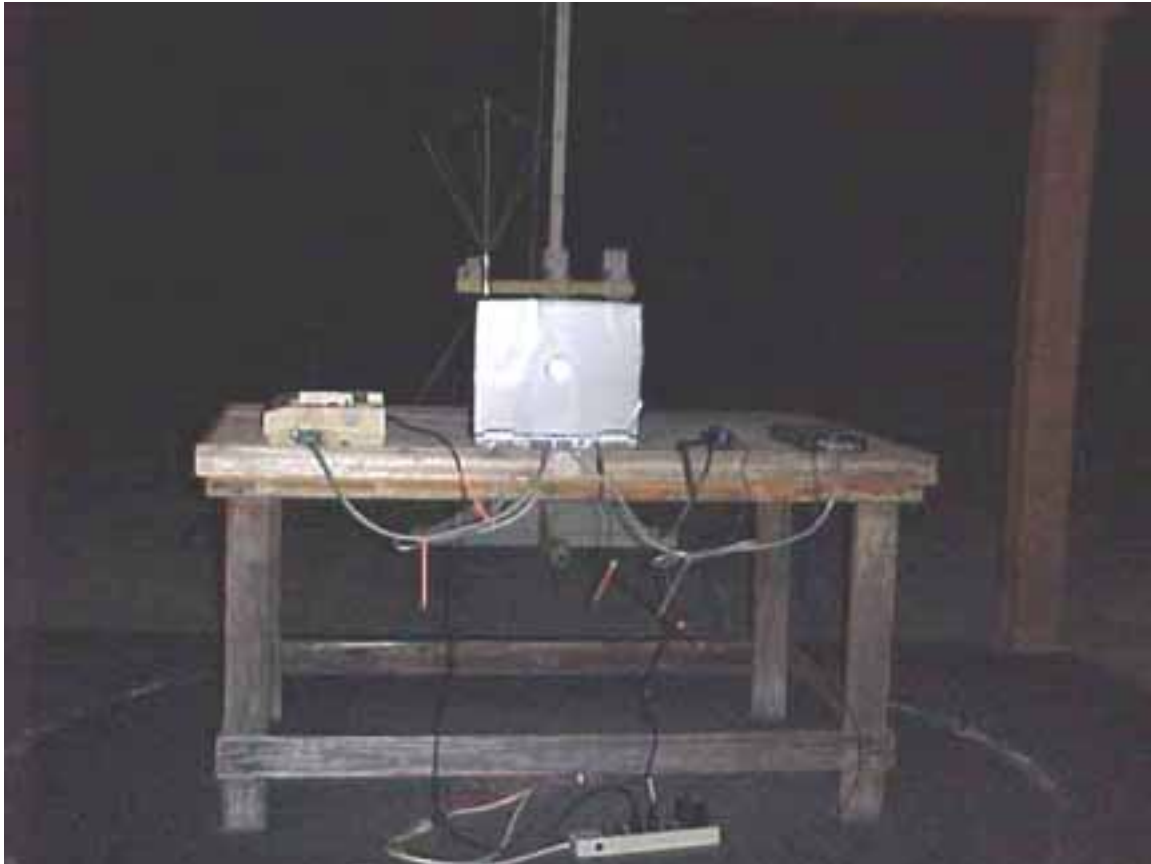

REAR VIEW

DELL COMPUTER CORPORATION
INTEL MINI PCI TYPE 3A 802.11 ABG WIRELESS LAN ADAPTER
FOR USE IN THE DELL LAPTOP AGENCY SERIES NUMBER: PP17L
MODEL: WM3A2915ABG
FCC SUBPART B AND E – RADIATED EMISSIONS

**PHOTOGRAPH SHOWING THE EUT CONFIGURATION
FOR MAXIMUM EMISSIONS**

Brea Division
114 Olinda Drive
Brea, CA 92823
(714) 579-0500

Agoura Division
2337 Troutdale Drive
Agoura, CA 91301
(818) 597-0600

Silverado Division
19121 El Toro Road
Silverado, CA 92676
(949) 589-0700

Lake Forest Division
20621 Pascal Way
Lake Forest, CA 92630
(949) 587-0400

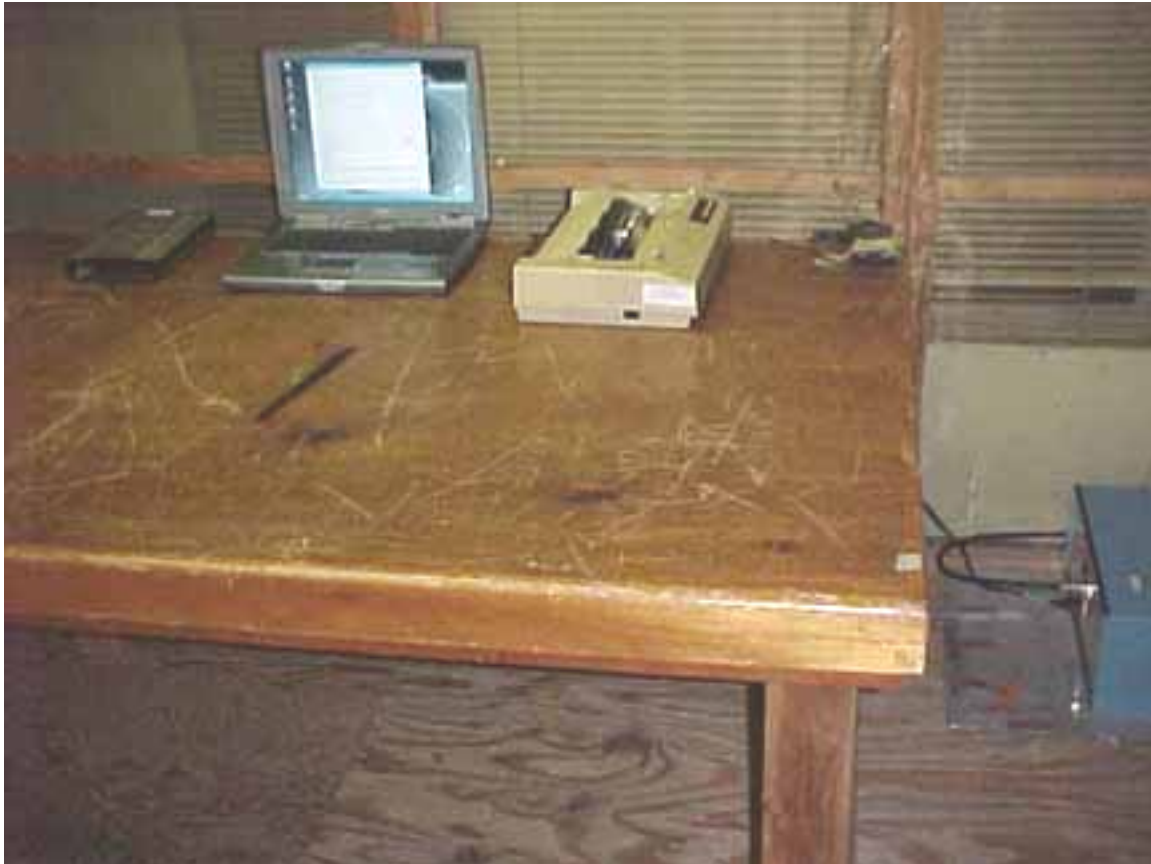

FRONT VIEW

DELL COMPUTER CORPORATION
INTEL MINI PCI TYPE 3A 802.11 ABG WIRELESS LAN ADAPTER
FOR USE IN THE DELL LAPTOP AGENCY SERIES NUMBER: PP17L
MODEL: WM3A2915ABG
FCC SUBPART B AND E – CONDUCTED EMISSIONS

**PHOTOGRAPH SHOWING THE EUT CONFIGURATION
FOR MAXIMUM EMISSIONS**

Brea Division
114 Olinda Drive
Brea, CA 92823
(714) 579-0500

Agoura Division
2337 Troutdale Drive
Agoura, CA 91301
(818) 597-0600

Silverado Division
19121 El Toro Road
Silverado, CA 92676
(949) 589-0700

Lake Forest Division
20621 Pascal Way
Lake Forest, CA 92630
(949) 587-0400



REAR VIEW

DELL COMPUTER CORPORATION
INTEL MINI PCI TYPE 3A 802.11 ABG WIRELESS LAN ADAPTER
FOR USE IN THE DELL LAPTOP AGENCY SERIES NUMBER: PP17L
MODEL: WM3A2915ABG
FCC SUBPART B AND E – CONDUCTED EMISSIONS

**PHOTOGRAPH SHOWING THE EUT CONFIGURATION
FOR MAXIMUM EMISSIONS**

Brea Division
114 Olinda Drive
Brea, CA 92823
(714) 579-0500

Agoura Division
2337 Troutdale Drive
Agoura, CA 91301
(818) 597-0600

Silverado Division
19121 El Toro Road
Silverado, CA 92676
(949) 589-0700

Lake Forest Division
20621 Pascal Way
Lake Forest, CA 92630
(949) 587-0400

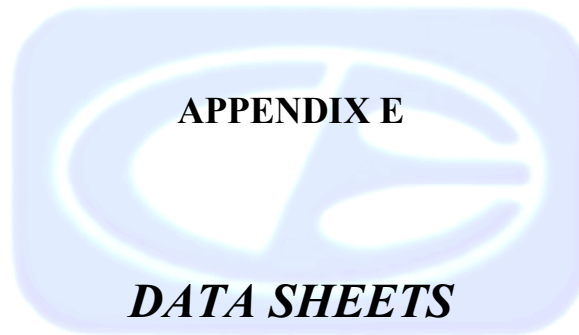

RADIATED EMISSIONS

DATA SHEETS

Test Location : Compatible Electronics Page : 1/1
 Customer : Intel Date : 3/15/2005
 Manufacturer : Intel Time : 19:11:36
 Eut name : Intel Mini PCI Type 3A 802.11abg Wi Lab : A
 Model : WMBA2915ABG Test Distance : 3.0
 Serial # : N/A
 Specification : FCC B
 Distance correction factor ($20 * \log(\text{test}/\text{spec})$) : 0.00
 Test Mode : Scan Type: Qualification w/ Phycomp Antenna
 Scan Range: 10 kHz to 1000 MHz (Vertical & Horizontal)
 Mode of Operation (worst case): Transmit
 Test Engineer: Benigno Chavez

Pol	Freq MHz	Rdng dBuV	Cable loss dB	Ant factor dB	Amp gain dB	Cor'd rdg = R dBuV	Li mit = L dBuV/m	Del ta R-L dB
1H	139.296	48.40	2.90	11.92	32.28	30.94	43.50	-12.56
2V	140.449	49.10	2.92	11.90	32.27	31.64	43.50	-11.86
3H	142.914	49.70	2.97	11.87	32.25	32.28	43.50	-11.22
4H	146.486	52.70	3.03	11.83	32.23	35.34	43.50	-8.16
5V	150.973	53.00	3.09	11.95	32.21	35.83	43.50	-7.67
6H	152.523	57.60	3.08	12.19	32.22	40.64	43.50	-2.86
7H	152.523Qp	52.86	3.08	12.19	32.22	35.90	43.50	-7.60
8V	154.297	51.00	3.06	12.46	32.24	34.28	43.50	-9.22
9H	178.186	45.10	2.91	14.89	32.40	30.50	43.50	-13.00
10V	178.890	41.80	2.92	14.78	32.40	27.09	43.50	-16.41
11H	185.784	43.70	2.94	14.93	32.40	29.17	43.50	-14.33
12H	202.048	43.80	3.01	15.74	32.41	30.14	43.50	-13.36
13H	220.741	50.60	3.08	16.05	32.48	37.25	46.00	-8.75
14V	232.177	41.50	3.16	16.23	32.44	28.45	46.00	-17.55
15H	237.040	48.60	3.20	16.31	32.40	35.71	46.00	-10.29
16V	314.701	45.50	3.66	13.15	32.27	30.04	46.00	-15.96
17H	314.715	52.90	3.66	13.15	32.27	37.44	46.00	-8.56

CONDUCTED EMISSIONS

DATA SHEETS

EMISSION LEVEL [dBuV] PEAK
Graph for Peak & Average

3/15/2005 21:55:20

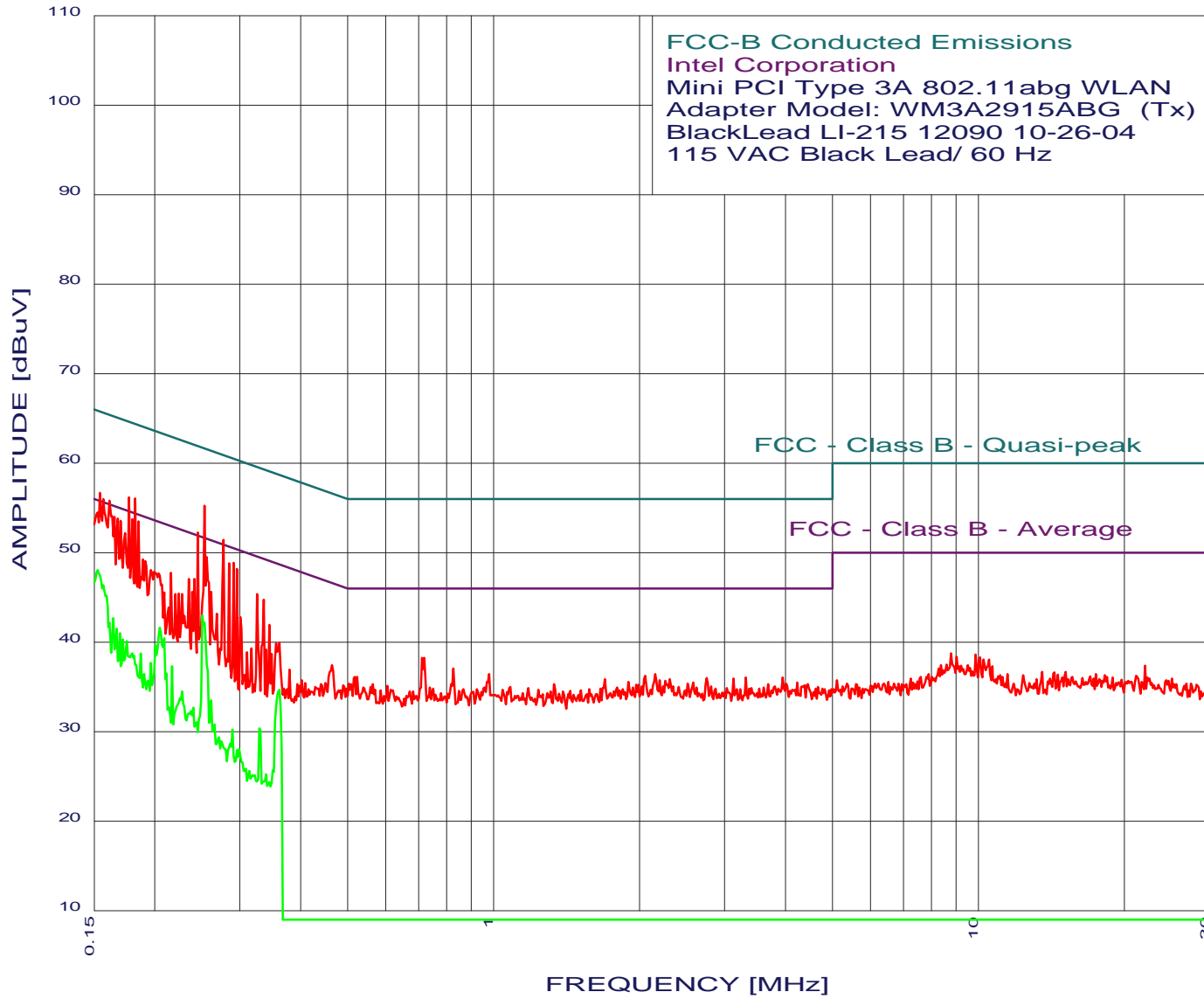



Intel Corporation
Mini PCI Type 3A 802.11abg Wireless LAN
Model: WM3A2915ABG (Transmit Mode)
With Phycomp Antenna
TEST ENGINEER : Benigno Chavez

40 highest peaks above -50.00 dB of FCC - Class B - Average limit line

Table with 5 columns: Peak#, Freq(MHz), Amp(dBuV), Limit(dB), Delta(dB). Contains 40 rows of peak data.

* Please See the Average Readings on the Next Page and on the Plot



Intel Corporation
Mini PCI Type 3A 802.11abg Wireless LAN
Model: WM3A2915ABG (Transmit Mode)
With Phycomp Antenna
TEST ENGINEER : Benigno Chavez

41 highest peaks above -50.00 dB of FCC - Class B - Average limit line
Peak criteria : 0.10 dB, Curve : Average

Table with 5 columns: Peak#, Freq(MHz), Amp(dBuV), limit(dB), Delta(dB). Contains 41 rows of peak data.

EMISSION LEVEL [dBuV] PEAK
Graph for Peak & Average

3/15/2005 22:08:55

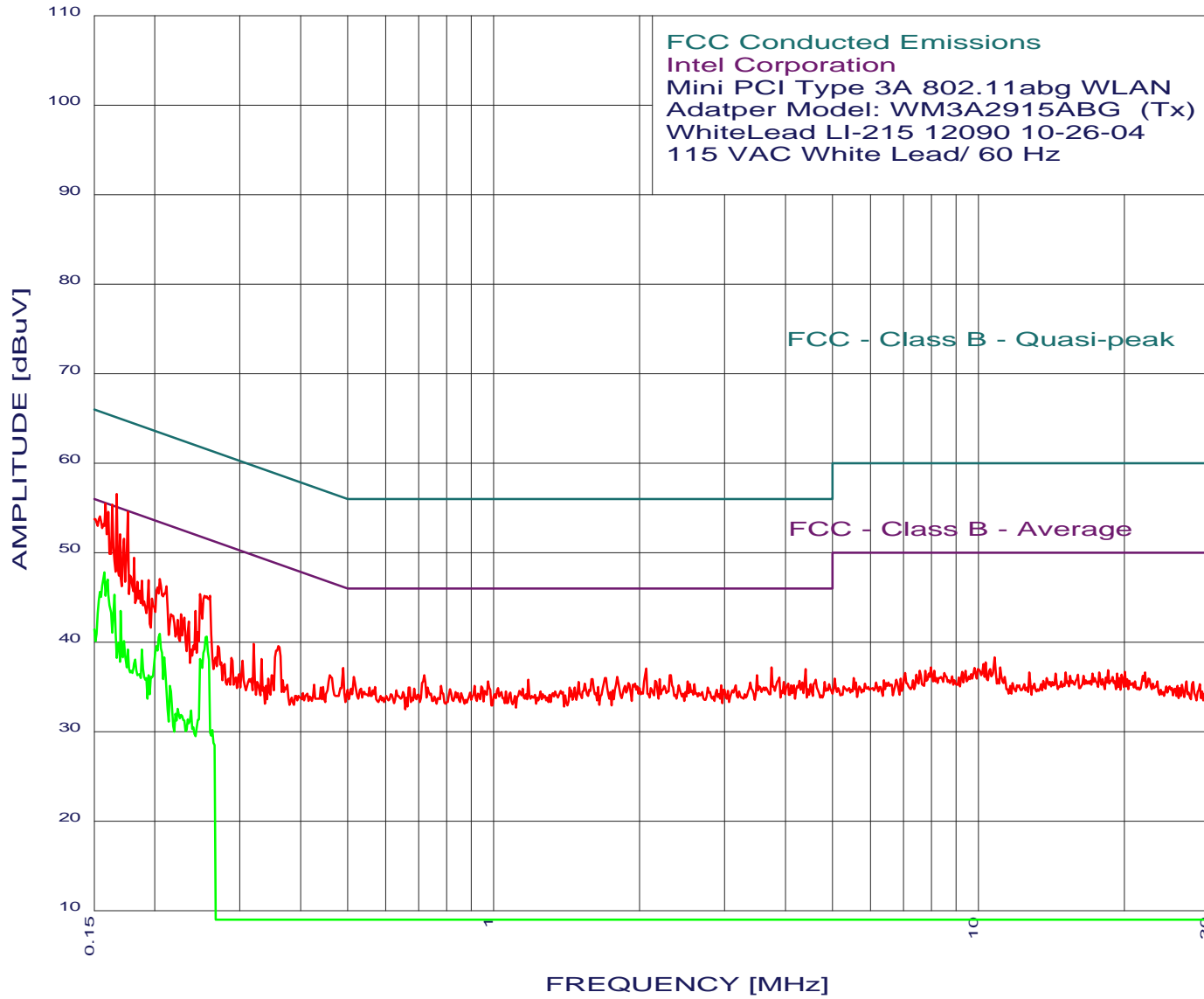

FCC Conducted Emissions
Intel Corporation
Mini PCI Type 3A 802.11abg WLAN
Adatper Model: WM3A2915ABG (Tx)
WhiteLead LI-215 12090 10-26-04
115 VAC White Lead/ 60 Hz





Intel Corporation
Mini PCI Type 3A 802.11abg Wireless LAN
WM3A2915ABG (Transmit Mode)
With Phycomp Antenna
TEST ENGINEER :Benigno Chavez

40 highest peaks above -50.00 dB of FCC - Class B - Average limit line

Table with 5 columns: Peak#, Freq(MHz), Amp(dBuV), Limit(dB), Delta(dB). Contains 40 rows of peak data.

* Please See the Average Readings on the Next Page and on the Plot



Intel Corporation
Mini PCI Type 3A 802.11abg Wireless LAN
WM3A2915ABG (Transmit Mode)
With Phycomp Antenna
TEST ENGINEER : Benigno Chavez

28 highest peaks above -50.00 dB of FCC - Class B - Average limit line
Peak criteria : 0.10 dB, Curve : Average

Table with 5 columns: Peak#, Freq(MHz), Amp(dBuV), Limit(dB), Delta(dB). Contains 28 rows of test data.

EMISSION LEVEL [dBuV] PEAK
Graph for Peak & Average

3/15/2005 22:00:10

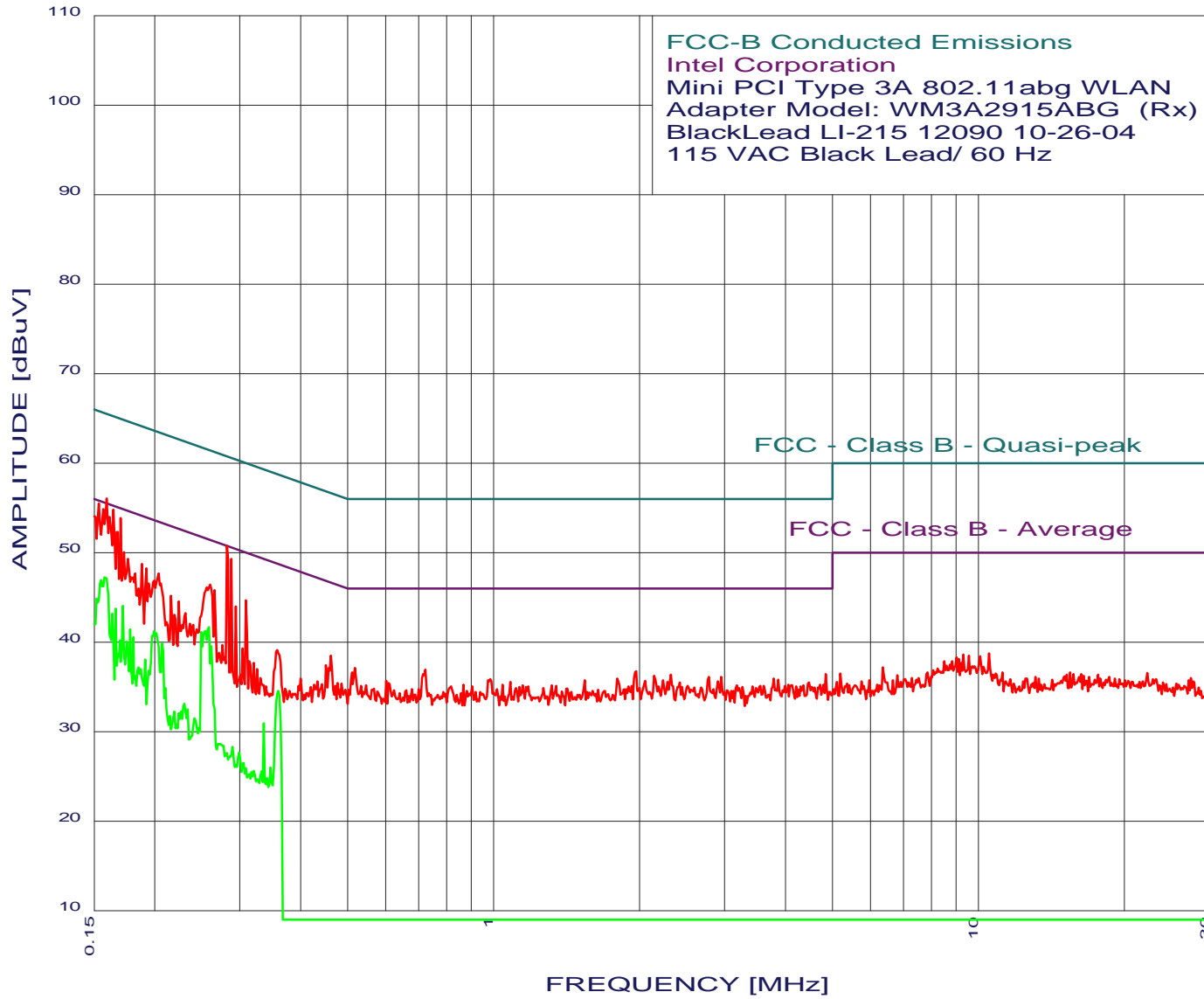



Intel Corporation
Mini PCI Type 3A 802.11abg Wireless LAN
Model: WM3A2915ABG (Receive Mode)
With Phycomp Antenna
TEST ENGINEER : Benigno Chavez

40 highest peaks above -50.00 dB of FCC - Class B - Average limit line

Peak criteria : 1.00 dB, Curve : Peak
Peak# Freq(MHz) Amp(dBuV) limit(dB) Delta(dB)

Table with 5 columns: Peak#, Freq(MHz), Amp(dBuV), limit(dB), Delta(dB). Contains 40 rows of peak data.

* Please See the Average Readings on the Next Page and on the Plot



Intel Corporation
Mini PCI Type 3A 802.11abg Wireless LAN
Model: WM3A2915ABG (Receive Mode)
With Phycomp Antenna
TEST ENGINEER : Benigno Chavez

41 highest peaks above -50.00 dB of FCC - Class B - Average limit line
Peak criteria : 0.10 dB, Curve : Average

Table with 5 columns: Peak#, Freq(MHz), Amp(dBuV), Limit(dB), Delta(dB). Contains 41 rows of peak data.

EMISSION LEVEL [dBuV] PEAK
Graph for Peak & Average

3/15/2005 22:12:04

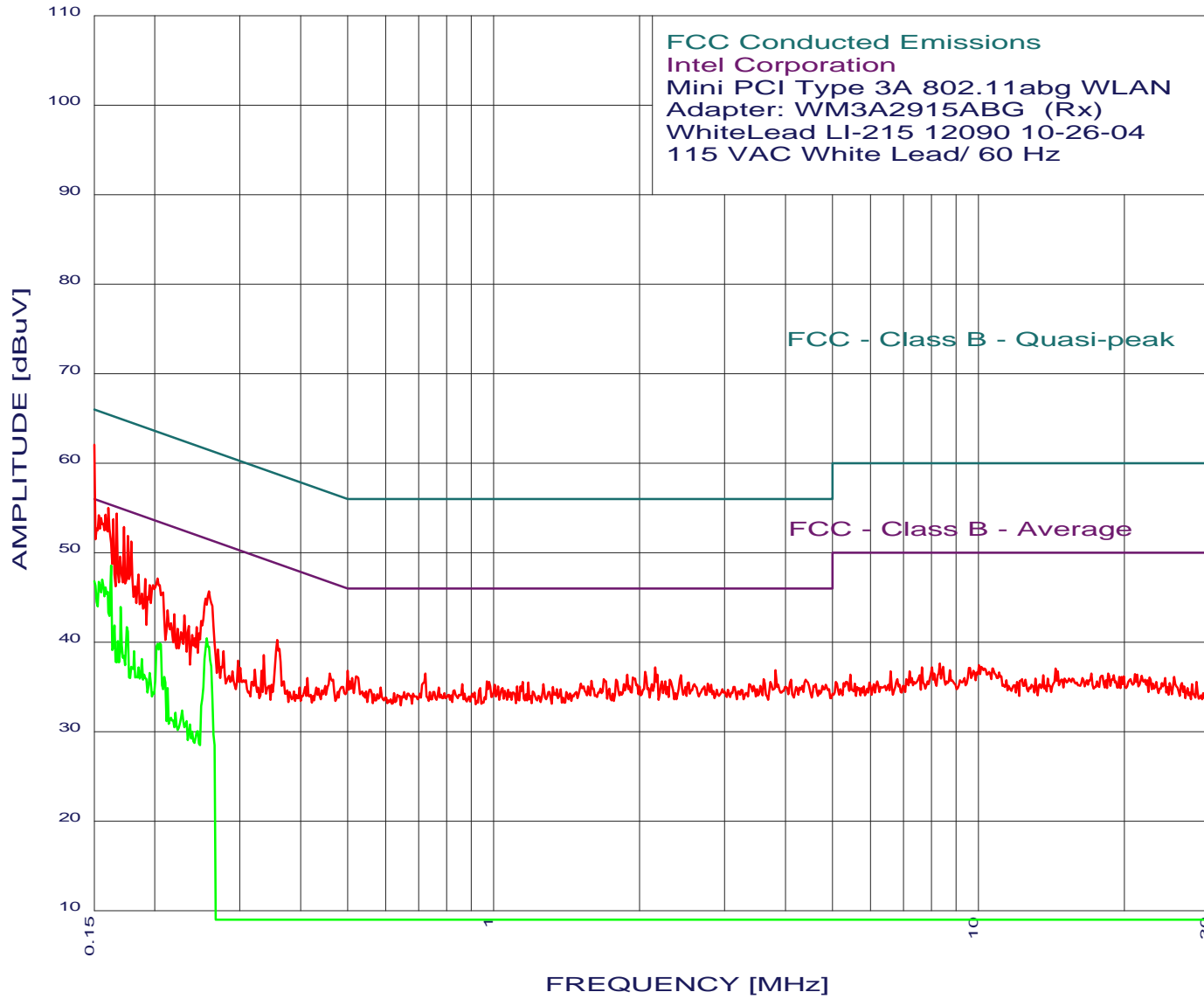



Intel Corporation
Mini PCI Type 3A 802.11abg Wireless LAN
Model: WM3A2915ABG (Receive Mode)
With Phycomp Antenna
TEST ENGINEER : Benigno Chavez

41 highest peaks above -50.00 dB of FCC - Class B - Average limit line
Peak criteria : 1.00 dB, Curve : Peak

Table with 5 columns: Peak#, Freq(MHz), Amp(dBuV), Limit(dB), Delta(dB). Contains 40 rows of peak data.

* Please See the Average Readings on the Next Page and on the Plot



Intel Corporation
Mini PCI Type 3A 802.11abg Wireless LAN
Model: WM3A2915ABG (Receive Mode)
With Phycomp Antenna
TEST ENGINEER : Benigno Chavez

30 highest peaks above -50.00 dB of FCC - Class B - Average limit line
Peak criteria : 0.10 dB, Curve : Average

Table with 5 columns: Peak#, Freq(MHz), Amp(dBuV), Limit(dB), Delta(dB). Contains 30 rows of peak measurement data.

EMISSION LEVEL [dBuV] PEAK
Graph for Peak

3/15/2005 22:04:19

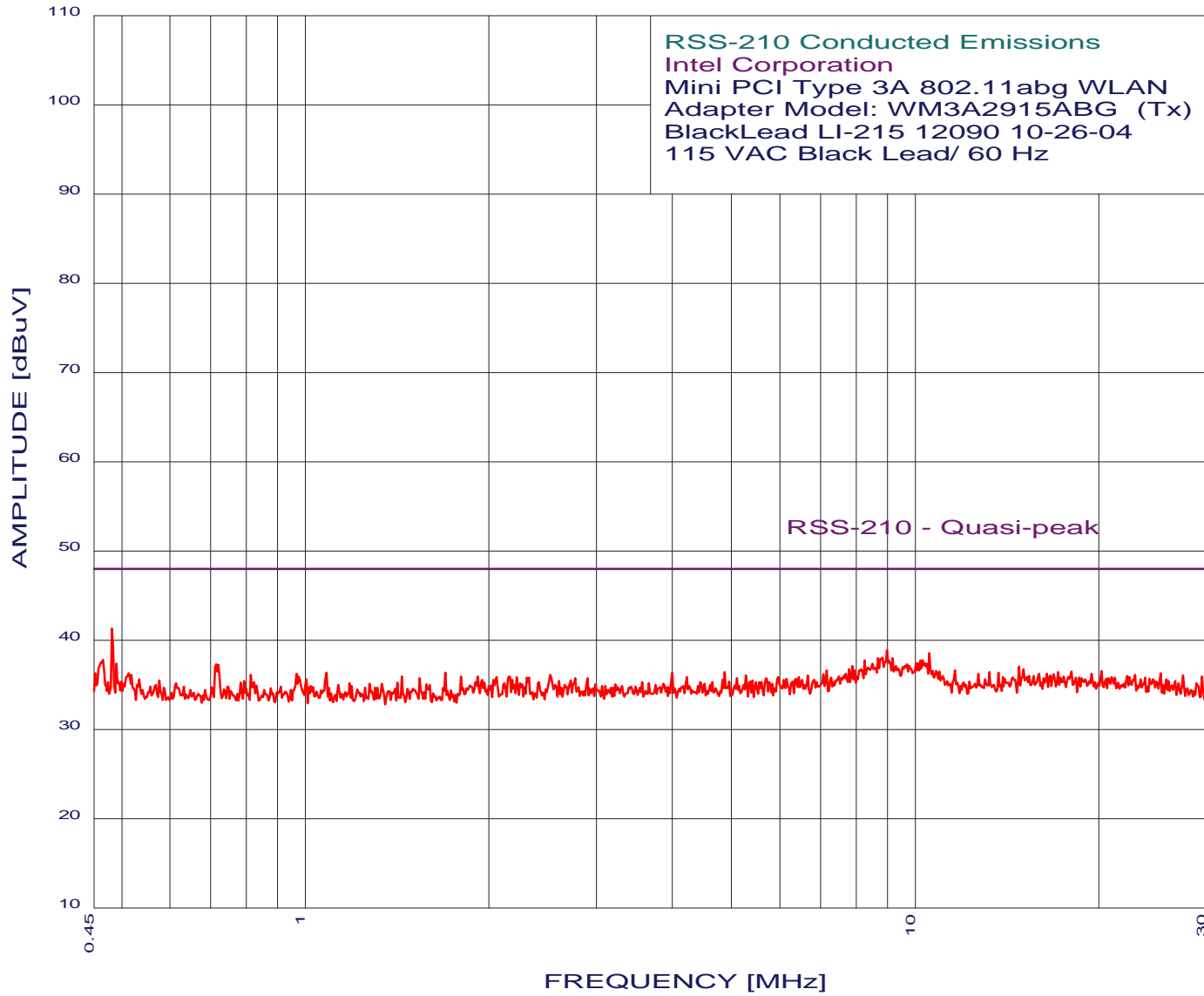



Intel Corporation
Mini PCI Type 3A 802.11abg Wireless LAN
Model: WM3A2915ABG (Transmit Mode)
With Phycomp Antenna
TEST ENGINEER : Benigno Chavez

41 highest peaks above -50.00 dB of RSS-210 - Quasi-peak limit line

Table with 5 columns: Peak#, Freq(MHz), Amp(dBuV), limit(dB), Delta(dB). Contains 41 rows of peak data.

EMISSION LEVEL [dBuV] PEAK
Graph for Peak

3/15/2005 22:15:13

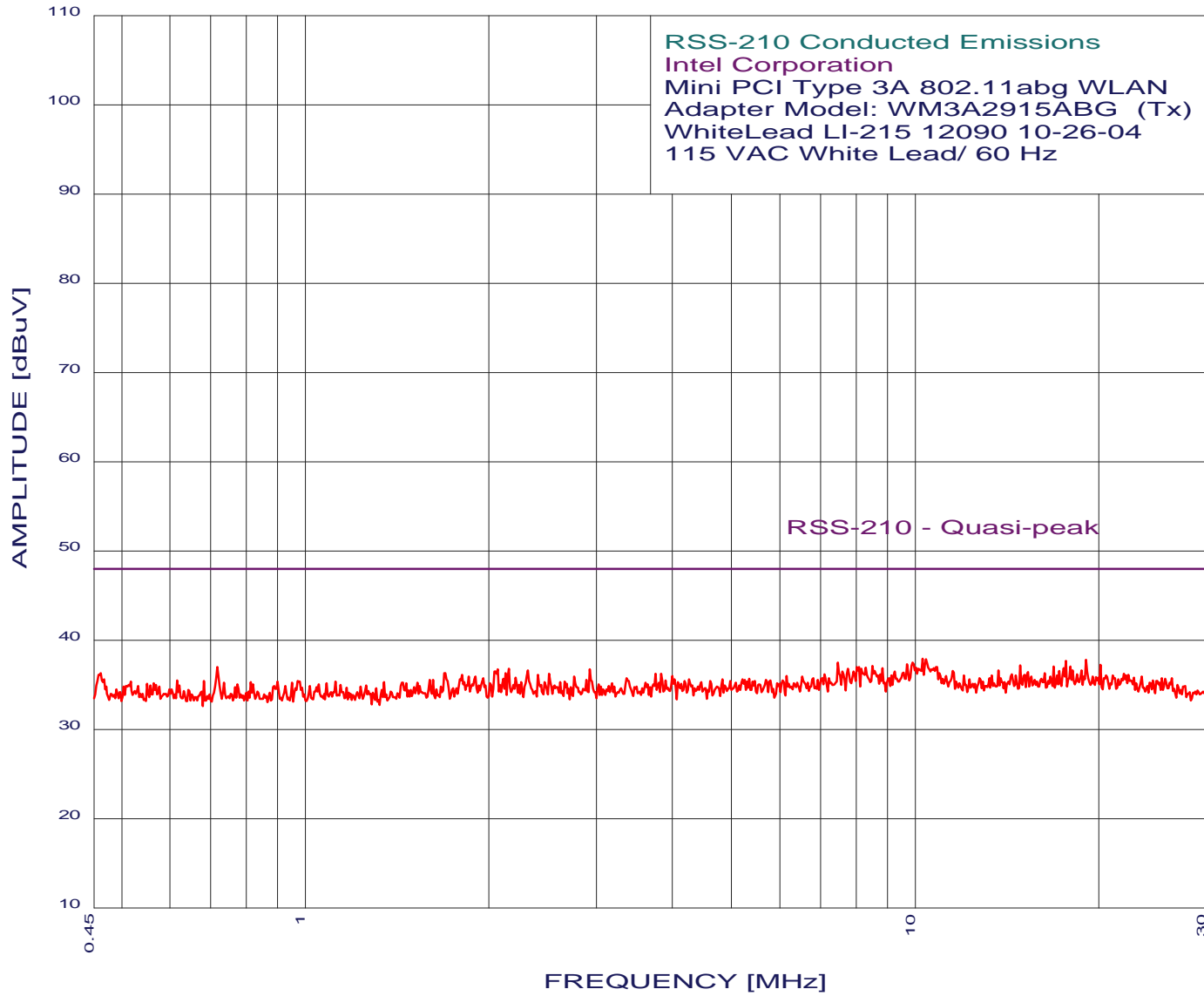



Intel Corporation
Mini PCI Type 3A 802.11abg Wireless LAN
WM3A2915ABG (Transmit Mode)
With Phycomp Antenna
TEST ENGINEER :Benigno Chavez

41 highest peaks above -50.00 dB of RSS-210 - Quasi-peak limit line

Table with 5 columns: Peak#, Freq(MHz), Amp(dBuV), limit(dB), Delta(dB). Contains 41 rows of peak data.

EMISSION LEVEL [dBuV] PEAK
Graph for Peak

3/15/2005 22:02:26

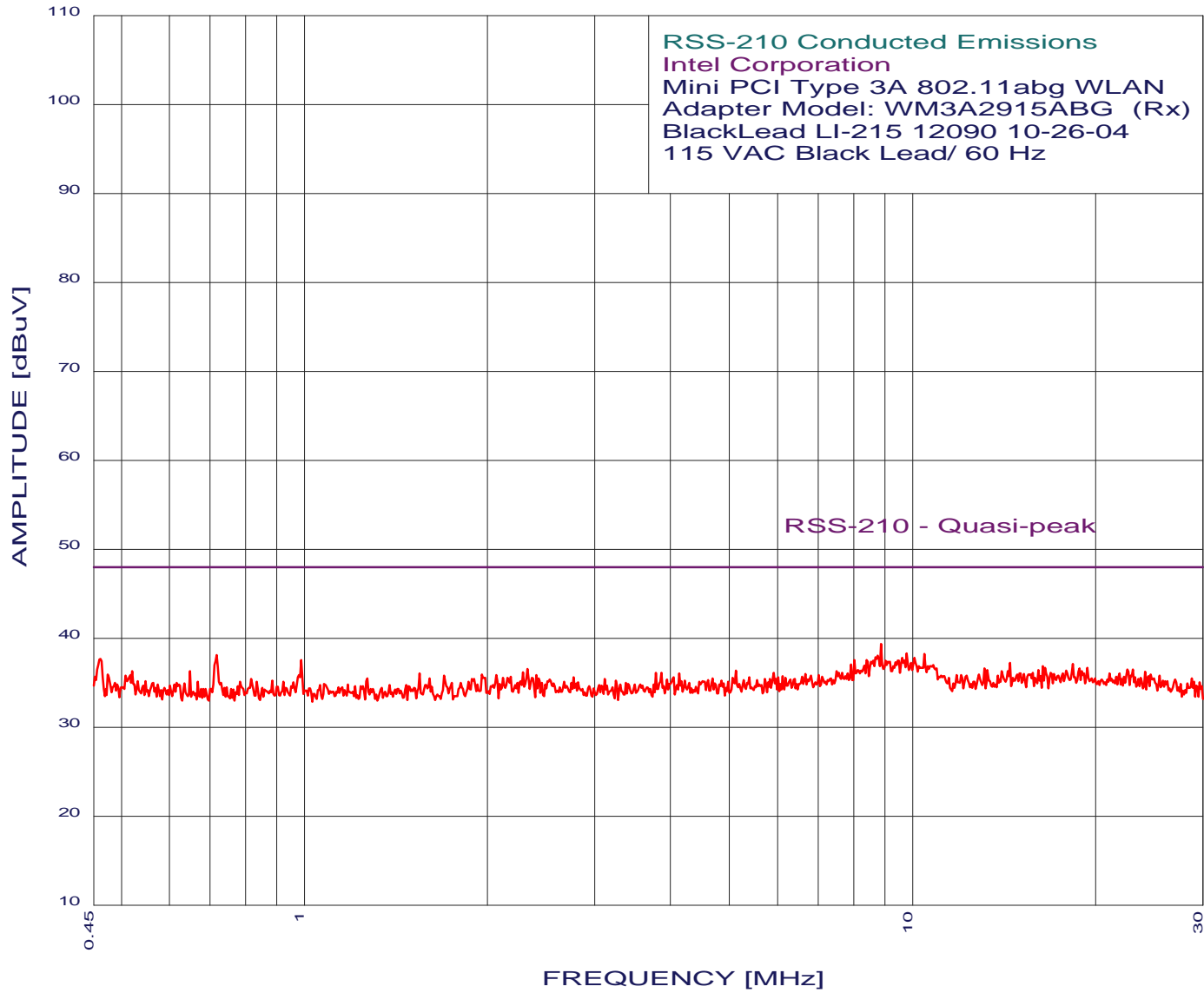



Intel Corporation
Mini PCI Type 3A 802.11abg Wireless LAN
WM3A2915ABG (Receive Mode)
With Phycomp Antenna
TEST ENGINEER : Benigno Chavez

41 highest peaks above -50.00 dB of RSS-210 - Quasi-peak limit line

Table with 5 columns: Peak#, Freq(MHz), Amp(dBuV), limit(dB), Delta(dB). Contains 41 rows of peak data.

EMISSION LEVEL [dBuV] PEAK
Graph for Peak

3/15/2005 22:13:10

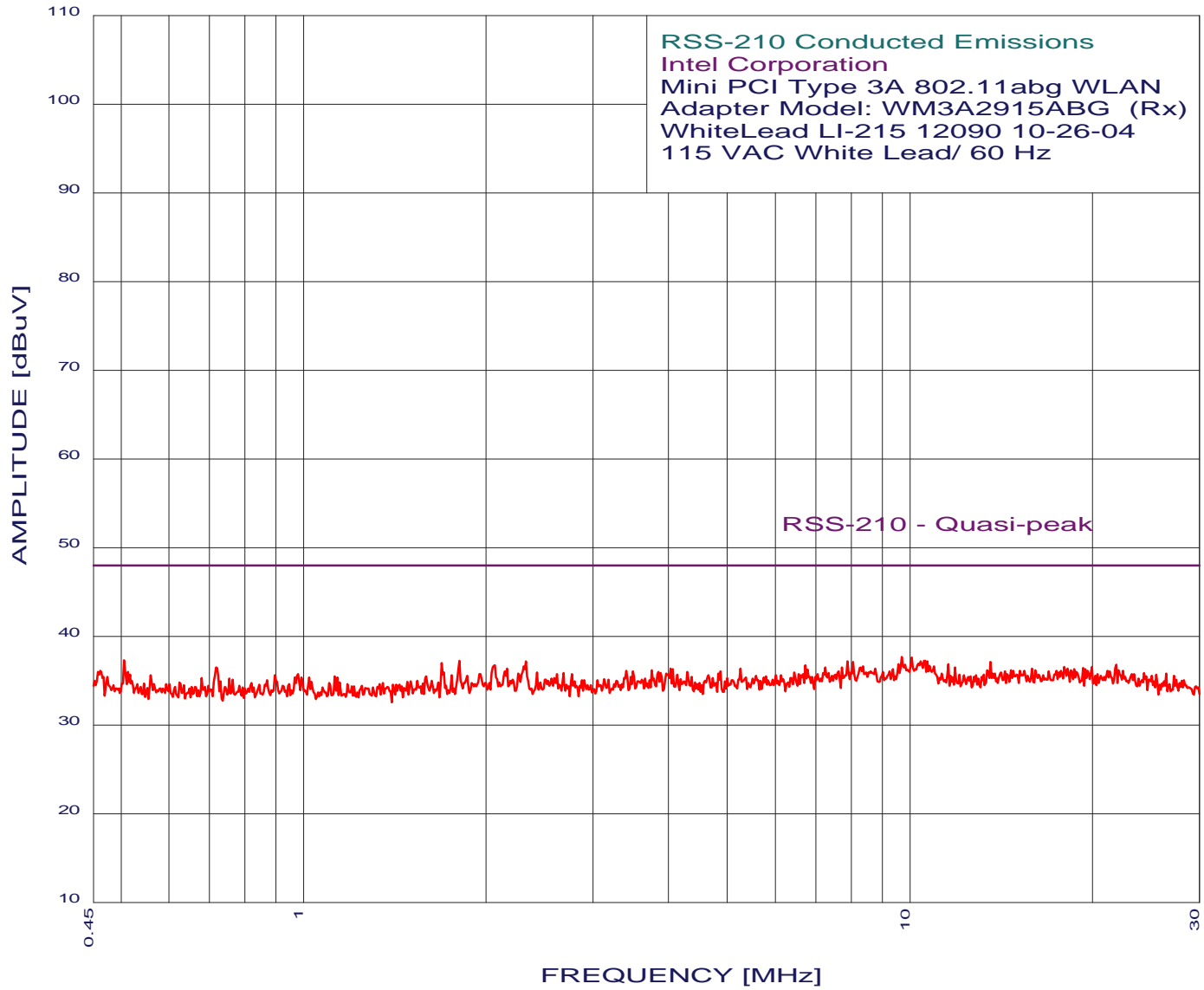

COMPATIBLE
ELECTRONICS



Intel Corporation
Mini PCI Type 3A 802.11abg Wireless LAN
WM3A2915ABG (Receive Mode)
With Phycomp Antenna
TEST ENGINEER : Benigno Chavez

41 highest peaks above -50.00 dB of RSS-210 - Quasi-peak limit line

Peak criteria : 1.00 dB, Curve : Peak

Table with 5 columns: Peak#, Freq(MHz), Amp(dBuV), Limit(dB), Delta(dB). Contains 41 rows of peak data.

-20 dB BANDWIDTH

DATA SHEETS



Ref Lvl	15 dBm	Marker 1 [T1 ndB]	ndB	20.00 dB	RBW	500 kHz	RF Att	40 dB
		BW	18.23647295 MHz		VBW	1 MHz	Unit	dBm
					SWT	5 ms		

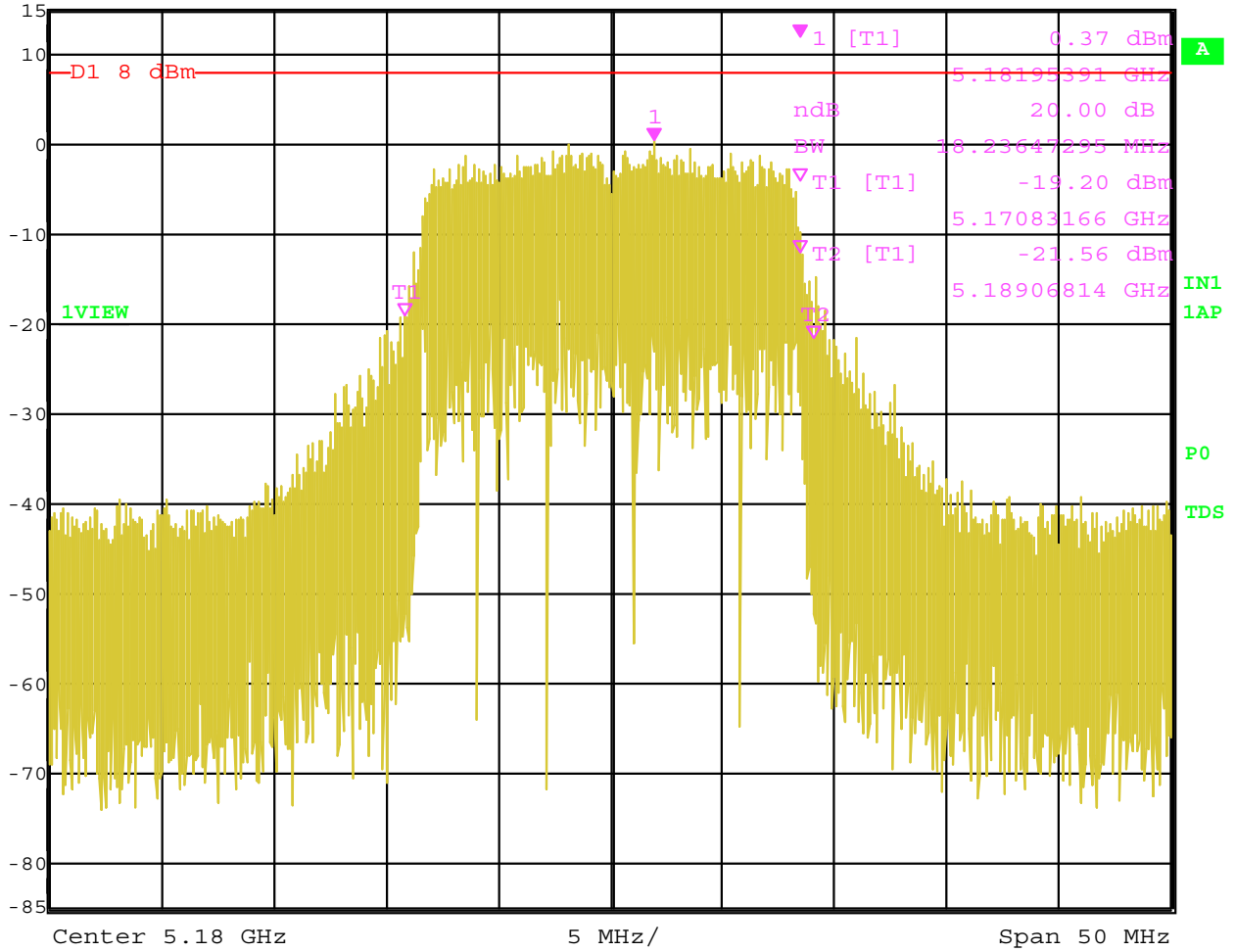

Date: 15.MAR.2005 08:54:40

Bandwidth 20 dB – Channel 36 – UNII Mode – Phycomp Antenna



Ref Lvl	15 dBm	Marker 1 [T1 ndB]	ndB	20.00 dB	RBW	500 kHz	RF Att	40 dB
		BW	17.93587174 MHz		VBW	1 MHz	Unit	dBm
					SWT	5 ms		

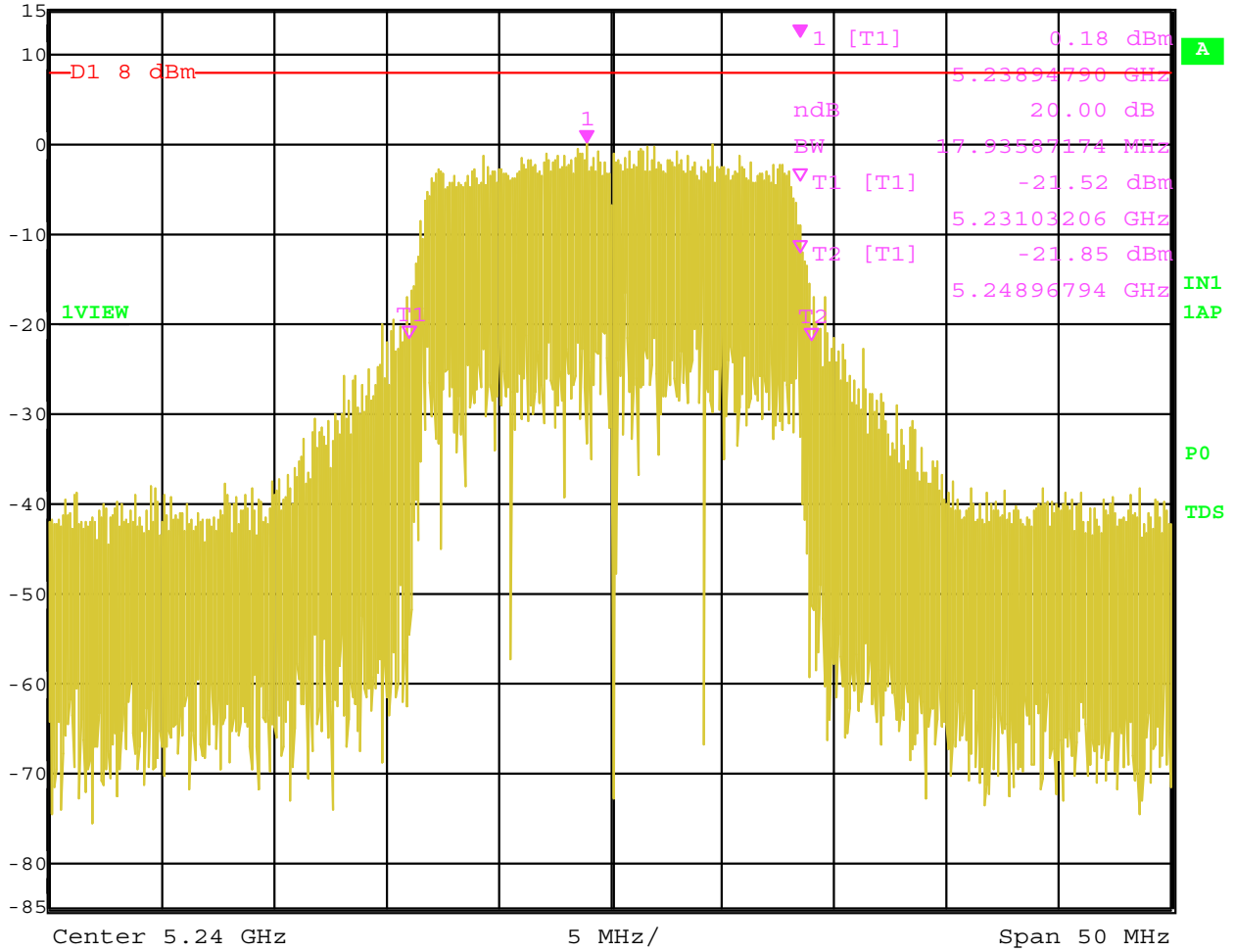

Date: 15.MAR.2005 08:56:07

Bandwidth 20 dB – Channel 48 – UNII Mode – Phycomp Antenna



Ref Lvl	15 dBm	Marker 1 [T1 ndB]	ndB	20.00 dB	RBW	500 kHz	RF Att	40 dB
		BW	17.83567134 MHz		VBW	1 MHz	Unit	dBm
					SWT	5 ms		

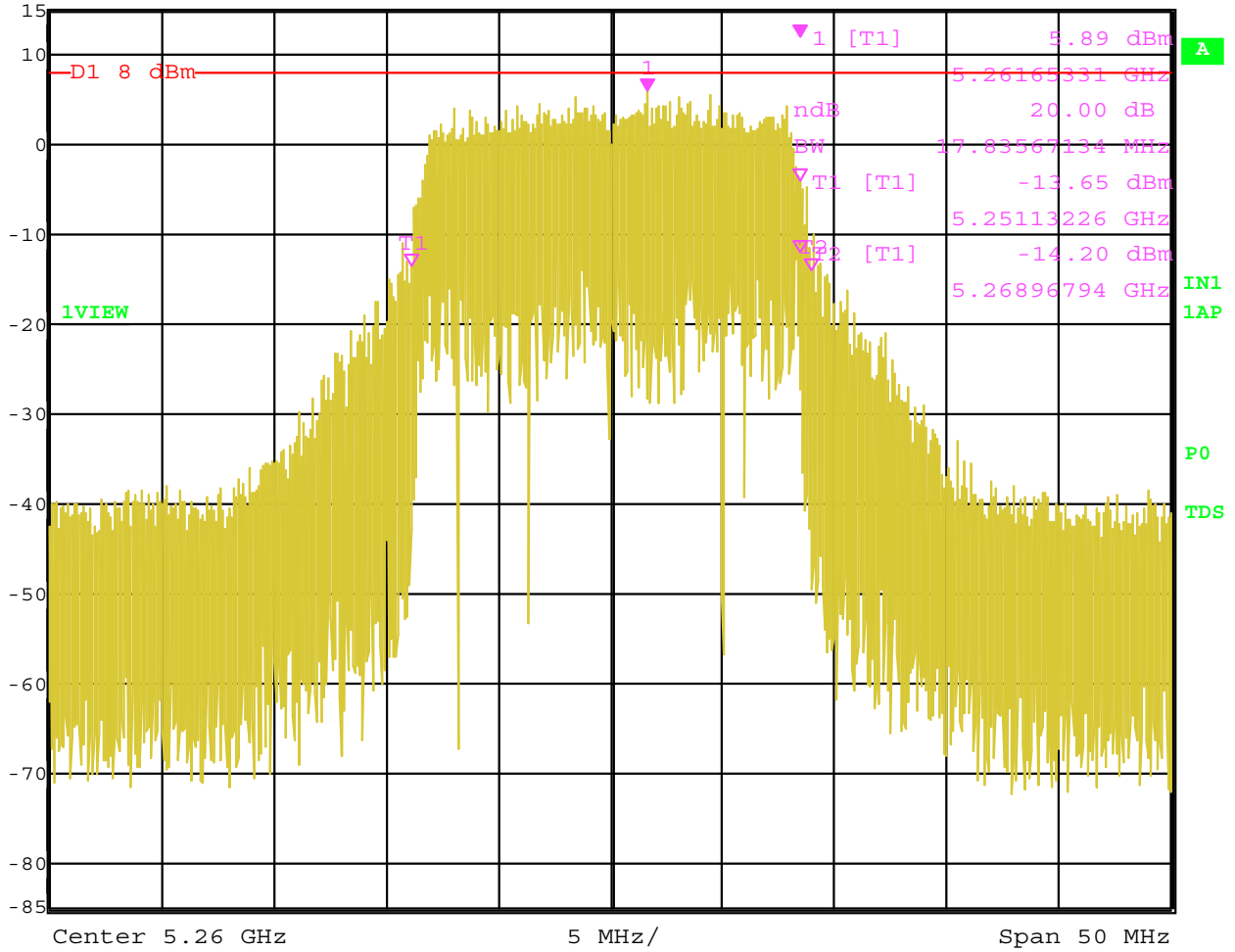

Date: 15.MAR.2005 09:02:25

Bandwidth 20 dB – Channel 52 – UNII Mode – Phycomp Antenna



Ref Lvl	15 dBm	Marker 1 [T1 ndB]	ndB	20.00 dB	RBW	500 kHz	RF Att	40 dB
		BW	18.33667335 MHz		VBW	1 MHz	Unit	dBm
		SWT				5 ms		

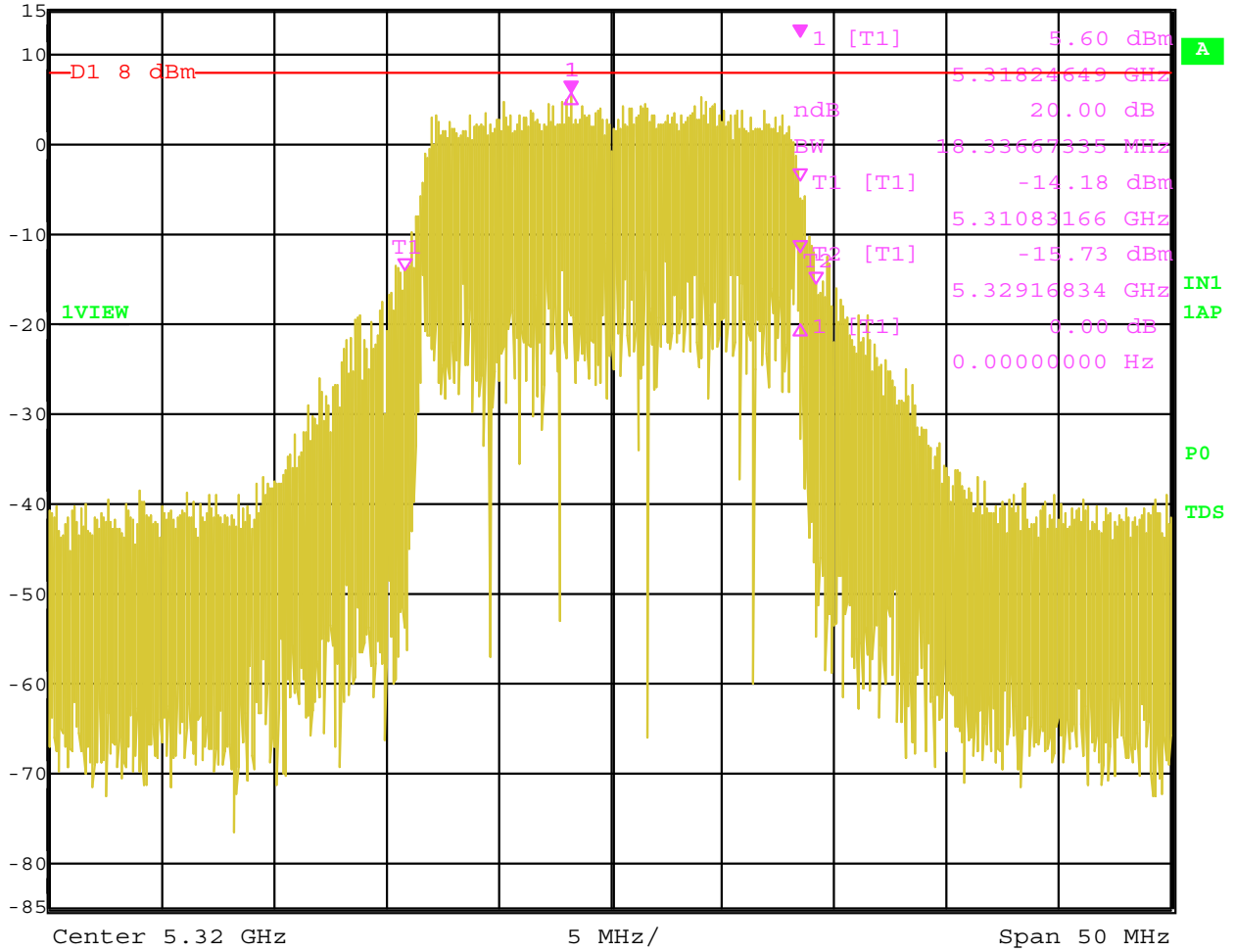

Date: 15.MAR.2005 09:04:12

Bandwidth 20 dB – Channel 64 – UNII Mode – Phycomp Antenna

-26 dB BANDWIDTH

DATA SHEETS



Ref Lvl	15 dBm	Marker 1 [T1 ndB]	ndB	26.00 dB	RBW	500 kHz	RF Att	40 dB
		BW	19.73947896 MHz		VBW	1 MHz	Unit	dBm
					SWT	5 ms		

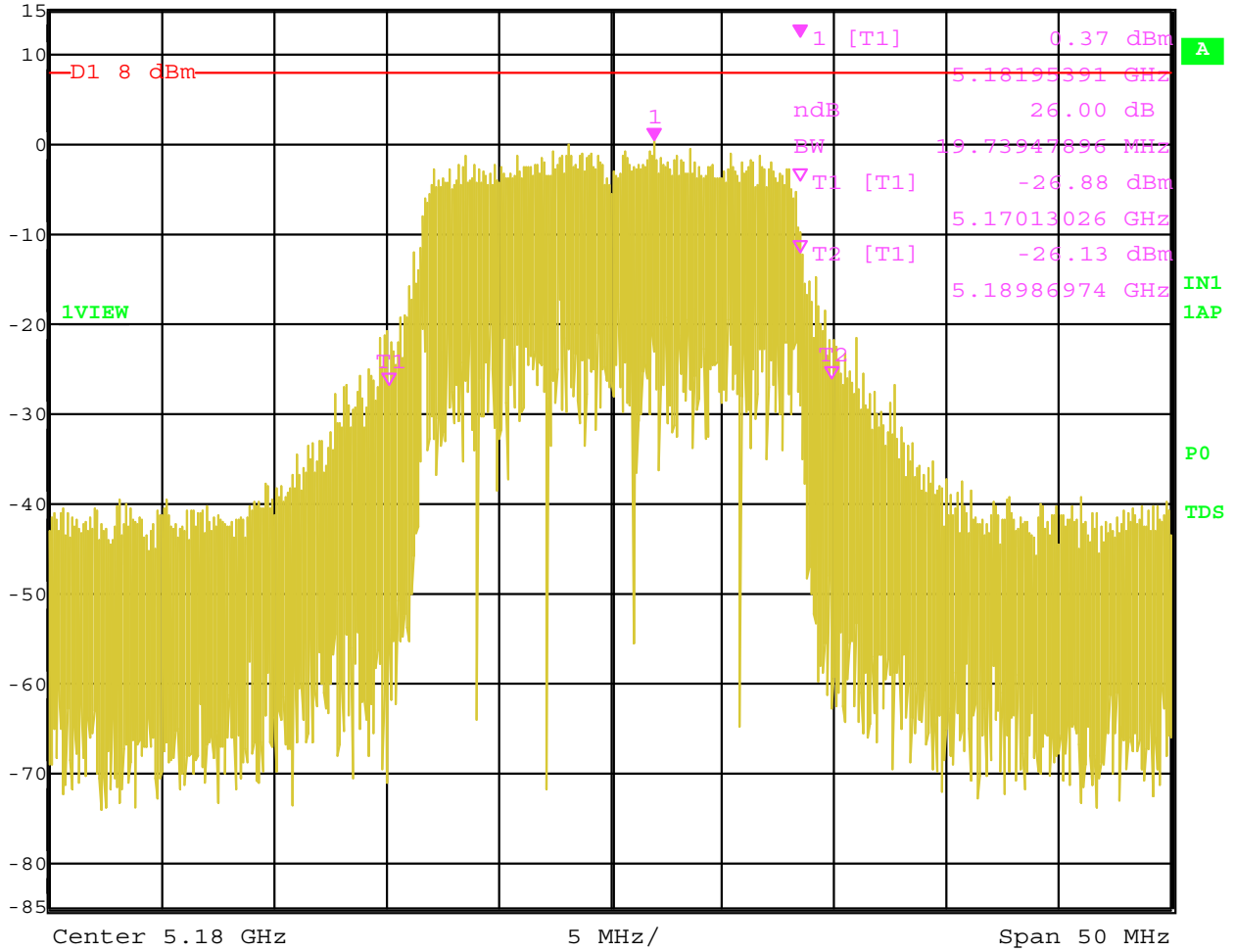

Date: 15.MAR.2005 08:53:30

Bandwidth 26 dB – Channel 36 – UNII Mode – Phycomp Antenna



Ref Lvl 15 dBm
Marker 1 [T1 ndB] 26.00 dB
RBW 500 kHz RF Att 40 dB
VBW 1 MHz
BW 20.14028056 MHz
SWT 5 ms Unit dBm

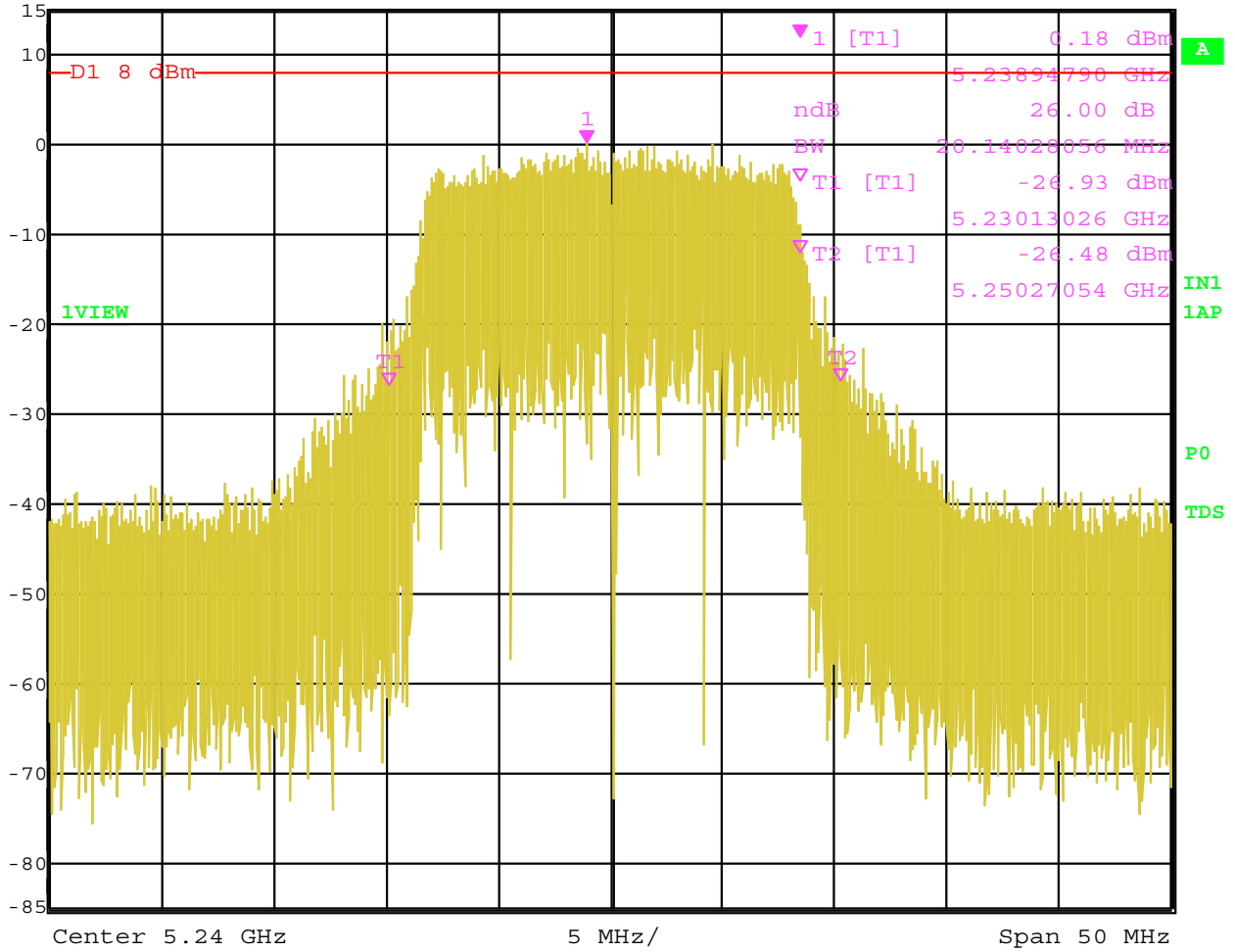

Date: 15.MAR.2005 08:56:40

Bandwidth 26 dB – Channel 48 – UNII Mode – Phycomp Antenna



Ref Lvl 15 dBm
Marker 1 [T1 ndB] 26.00 dB
RBW 500 kHz
RF Att 40 dB
VBW 1 MHz
Unit dBm
BW 19.83967936 MHz
SWT 5 ms

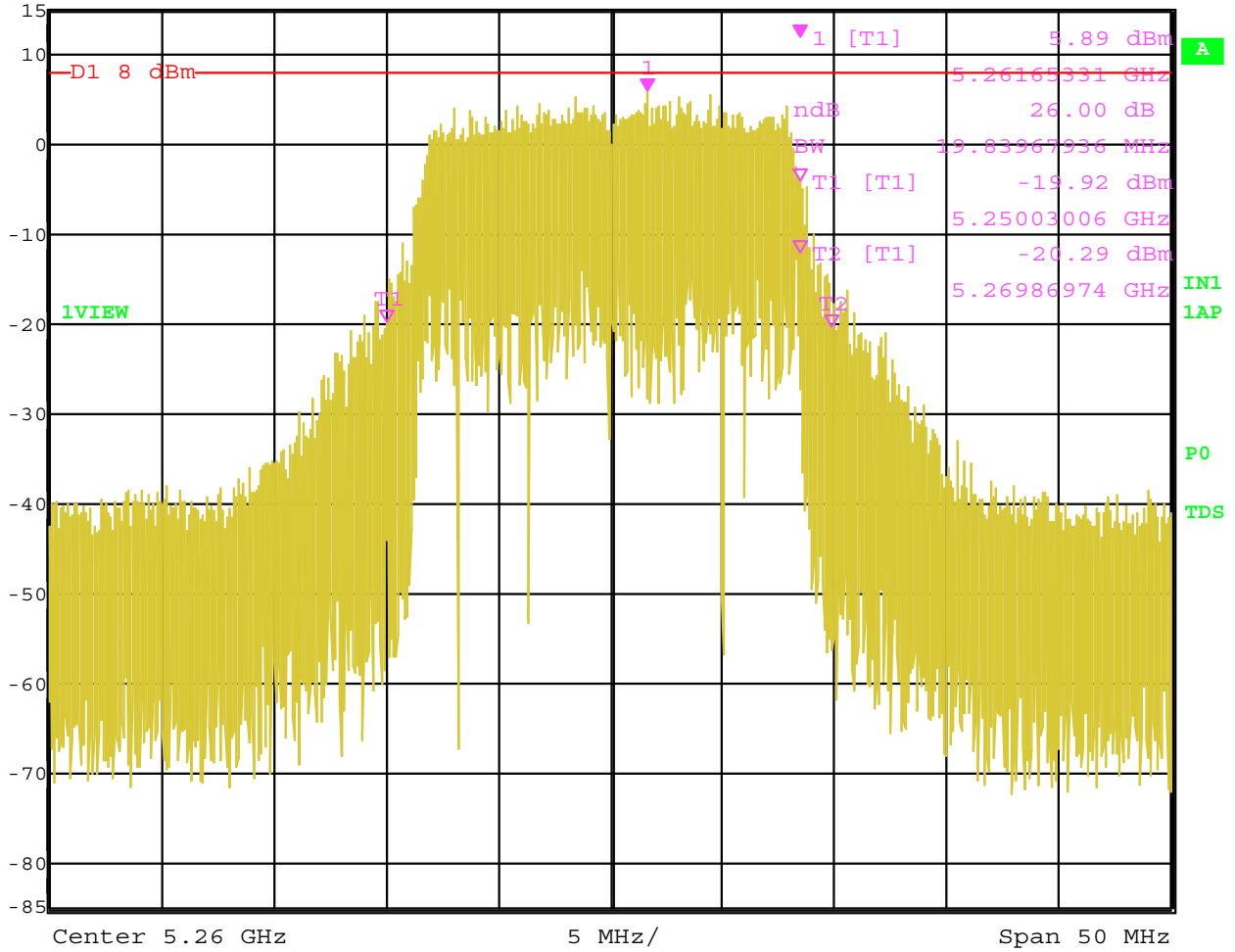

Date: 15.MAR.2005 09:02:55

Bandwidth 26 dB – Channel 52 – UNII Mode – Phycomp Antenna



Ref Lvl	15 dBm	Marker 1 [T1 ndB]	ndB	26.00 dB	RBW	500 kHz	RF Att	40 dB
		BW	19.93987976 MHz		VBW	1 MHz	Unit	dBm
					SWT	5 ms		

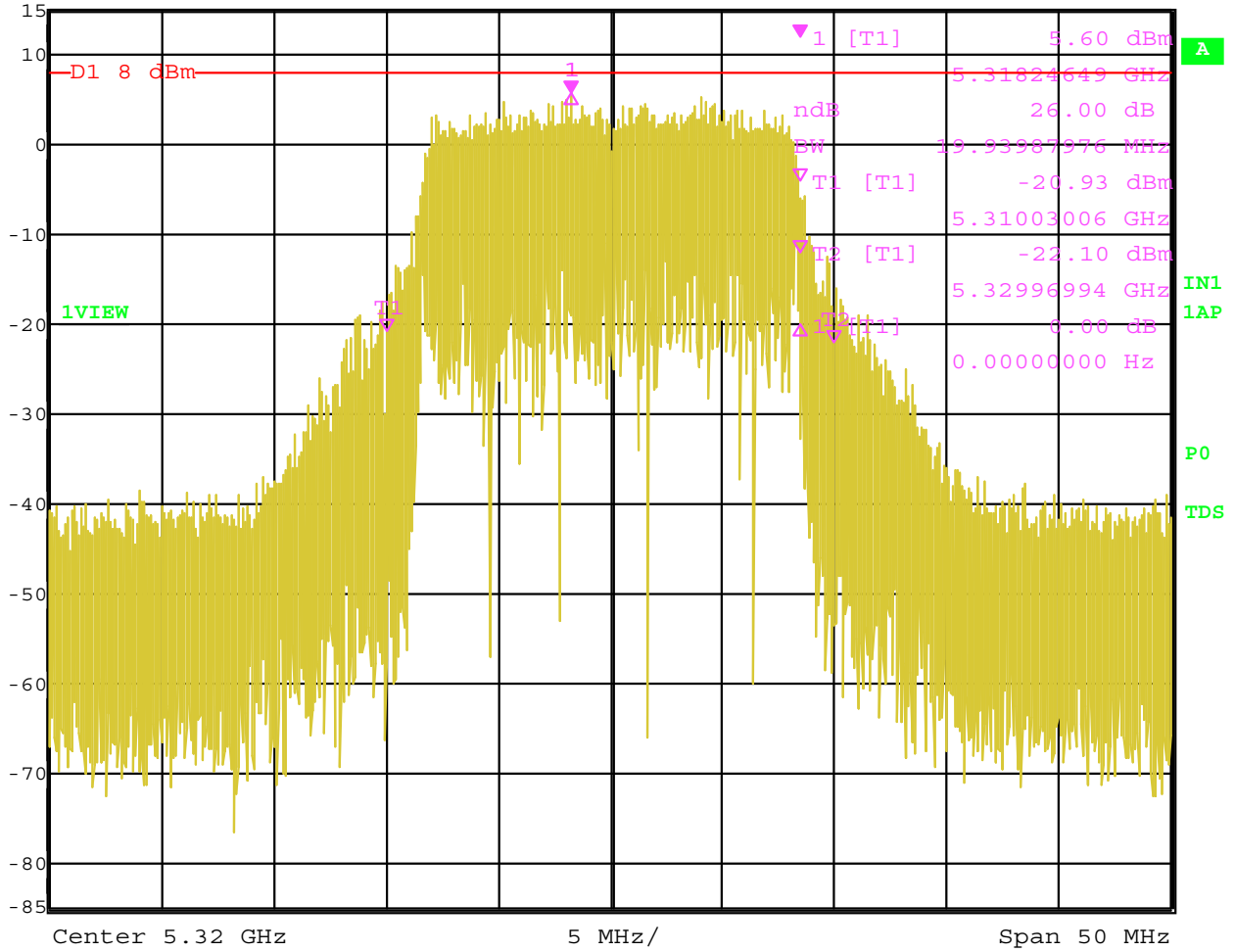

Date: 15.MAR.2005 09:04:42

Bandwidth 26 dB – Channel 64 – UNII Mode – Phycomp Antenna

PEAK TRANSMIT POWER

DATA SHEETS

PEAK OUTPUT POWER

Intel Corporation

Intel Mini PCI Type 3A 802.11 ABG Wireless LAN
Adapter

MODEL: WM3A2915ABG

With Phycomp Antenna

For use in the Dell Agency Series #: PP17L

UNII Mode (Worst Case Rate is 6 Mbps)

CHANNEL	GAIN	PEAK POWER OUTPUT (dBm)
36 (5180 MHz)	1.0	10.97
48 (5240 MHz)	1.5	10.99
52 (5260 MHz)	7.0	16.16
64 (5320 MHz)	7.0	15.90



PEAK POWER SPECTRAL DENSITY

DATA SHEETS



Ref Lvl	Marker 1 [T1]	RBW	1 MHz	RF Att	40 dB
15 dBm	-4.18 dBm	VBW	3 MHz	Unit	dBm
	5.18105210 GHz	SWT	5 ms		

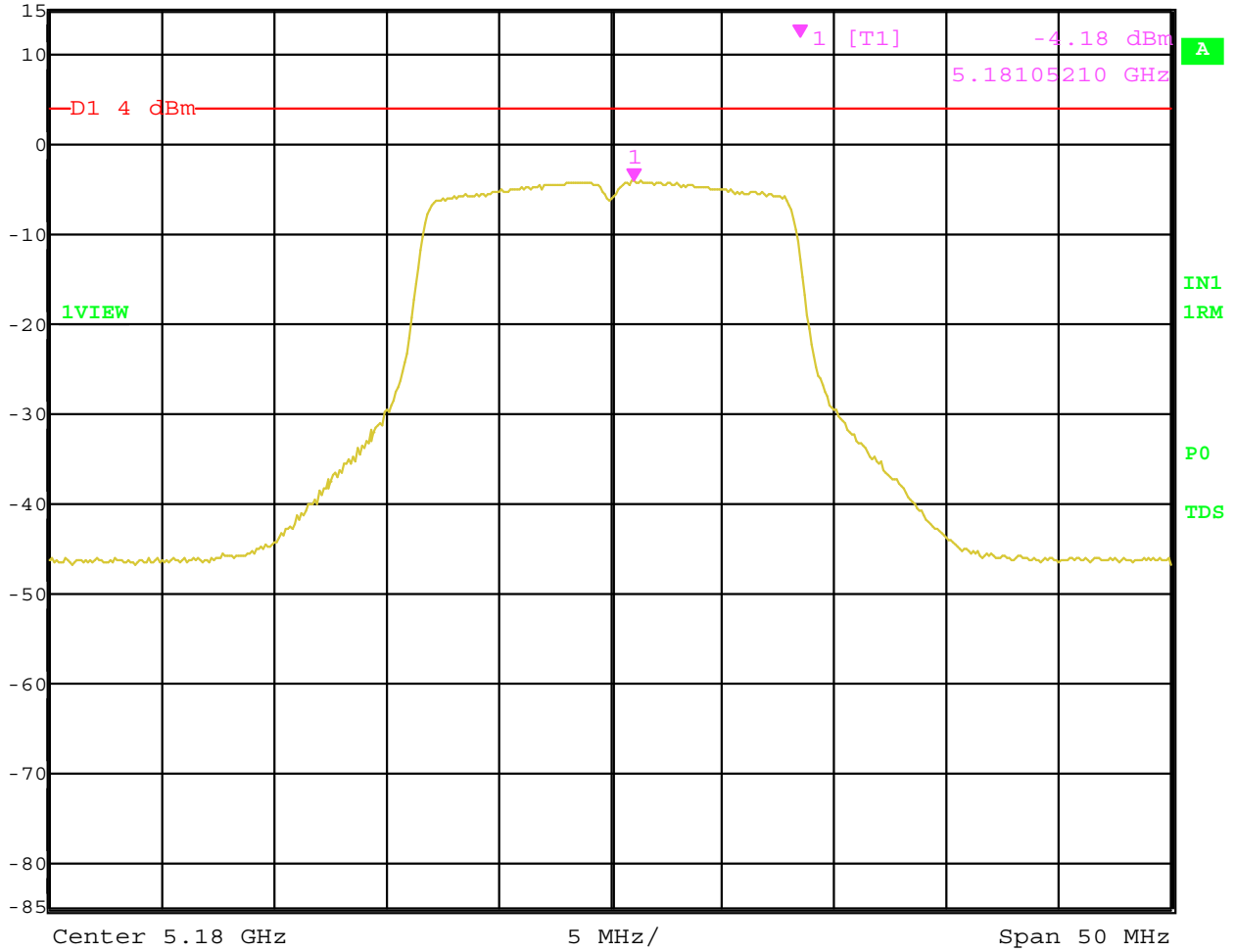

Date: 15.MAR.2005 09:13:20

Peak Power Spectral Density – Channel 36 – UNII Mode – Phycomp Antenna – FCC Method



Ref Lvl	Marker 1 [T1]	RBW	1 MHz	RF Att	40 dB
15 dBm	-4.23 dBm	VBW	3 MHz		
	5.24135271 GHz	SWT	5 ms	Unit	dBm

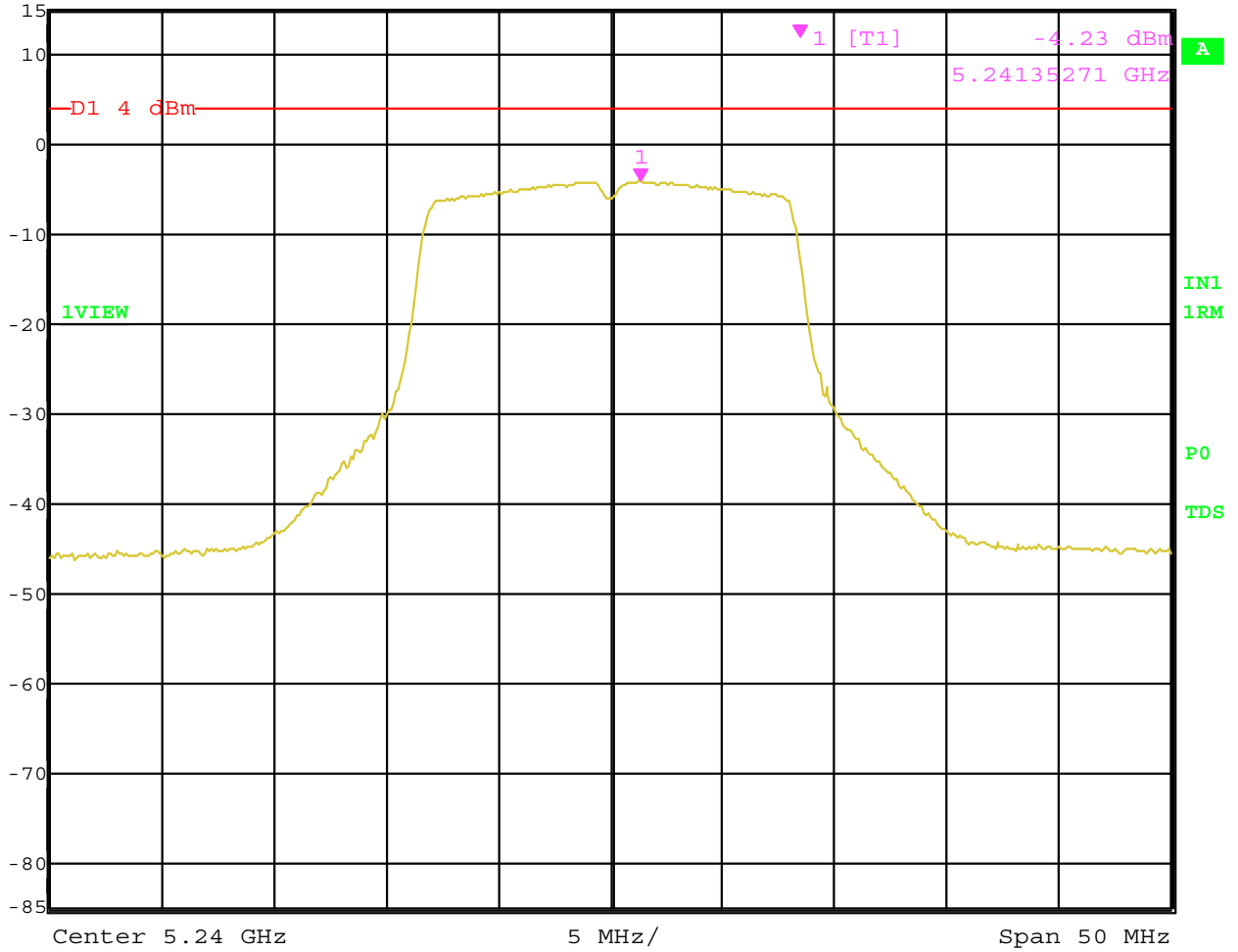

Date: 15.MAR.2005 09:12:34

Peak Power Spectral Density – Channel 48 – UNII Mode – Phycomp Antenna – FCC Method



Ref Lvl	15 dBm	Marker 1 [T1]	5.26125251 GHz	1.31 dBm	RBW	1 MHz	RF Att	40 dB
					VBW	3 MHz		
					SWT	5 ms	Unit	dBm

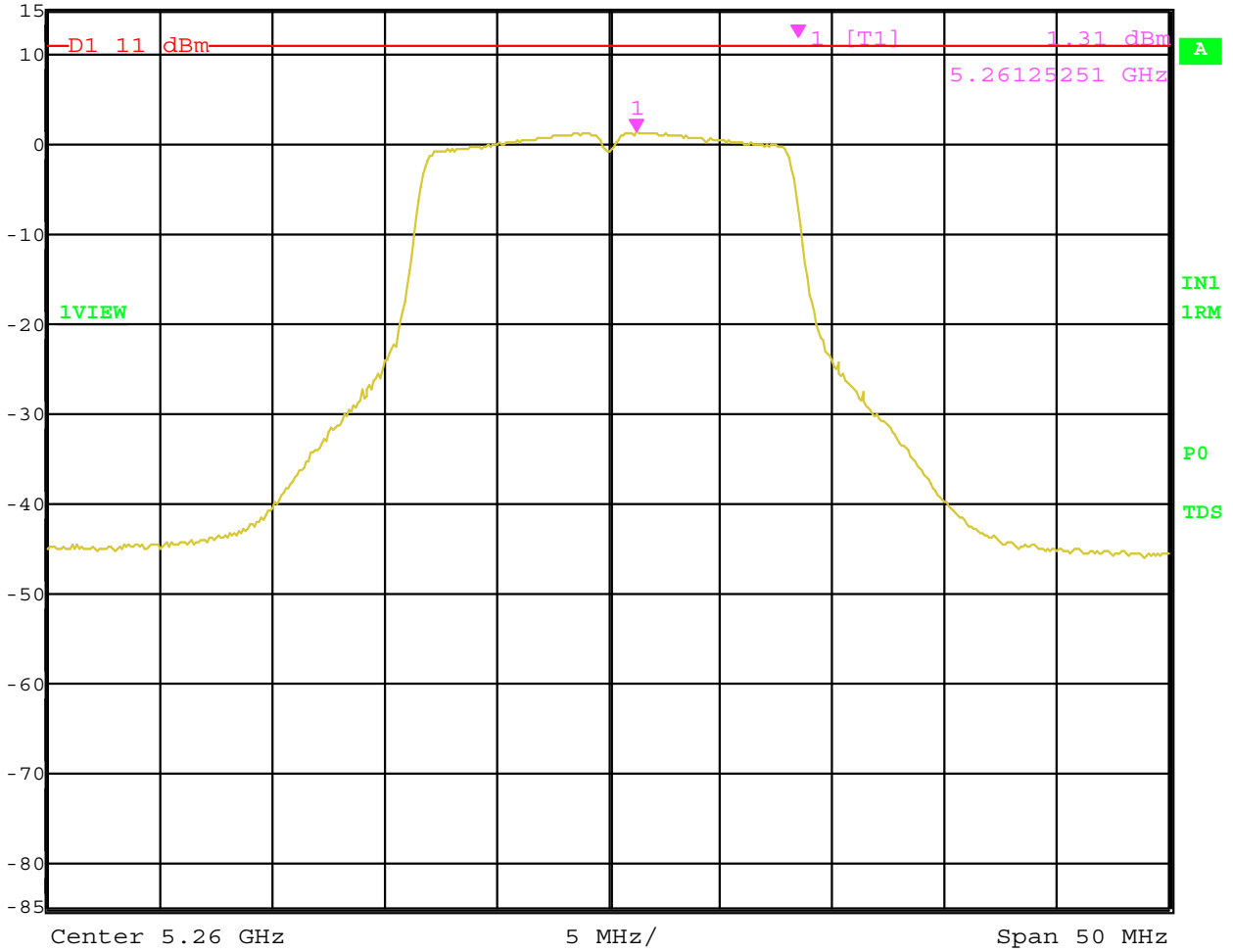

Date: 15.MAR.2005 09:11:45

Peak Power Spectral Density – Channel 52 – UNII Mode – Phycomp Antenna – FCC Method



Ref Lvl	Marker 1 [T1]	RBW	1 MHz	RF Att	40 dB
15 dBm	1.04 dBm	VBW	3 MHz		
	5.32135271 GHz	SWT	5 ms	Unit	dBm

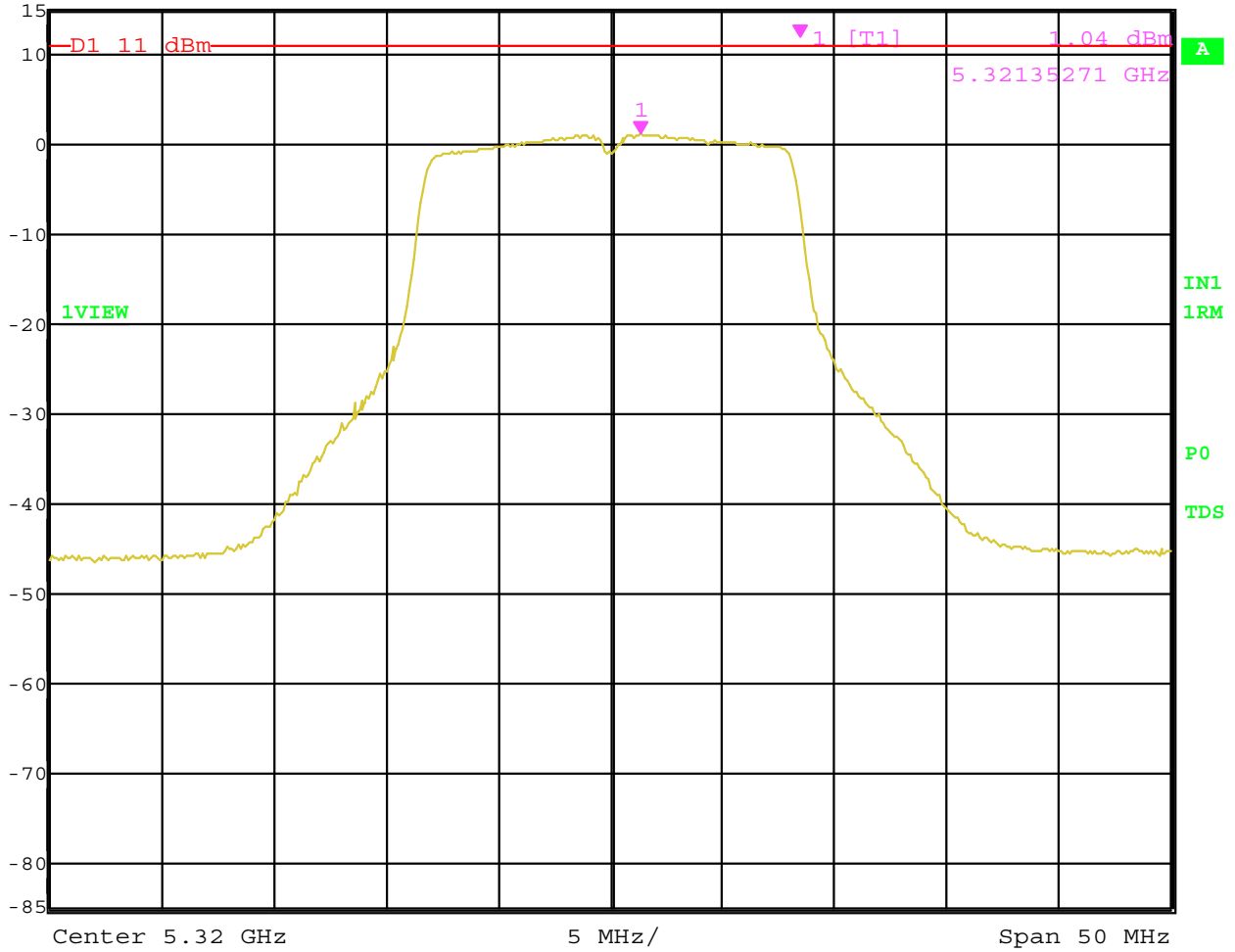

Date: 15.MAR.2005 09:11:06

Peak Power Spectral Density – Channel 64 – UNII Mode – Phycomp Antenna – FCC Method



Ref Lvl 15 dBm
Marker 1 [T2] 5.17504008 GHz -1.51 dBm
RBW 1 MHz RF Att 40 dB
VBW 1 MHz
SWT 5 ms Unit dBm

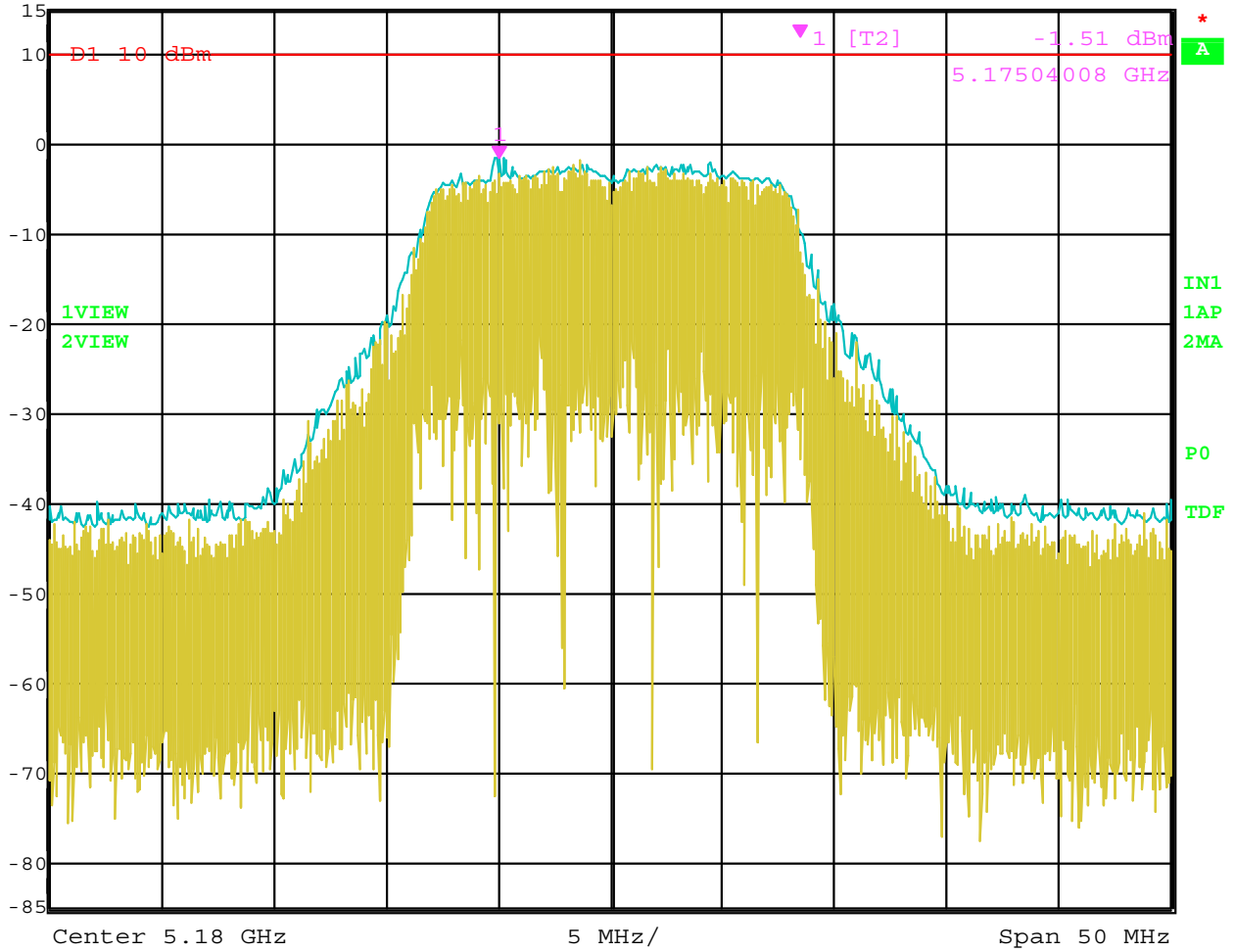

Date: 15.MAR.2005 09:33:01

Peak Power Spectral Density – Channel 36 – UNII Mode – Phycomp Antenna – RSS-210 Method



Ref Lvl 15 dBm
Marker 1 [T2] 5.23504008 GHz -1.51 dBm
RBW 1 MHz RF Att 40 dB
VBW 1 MHz
SWT 5 ms Unit dBm

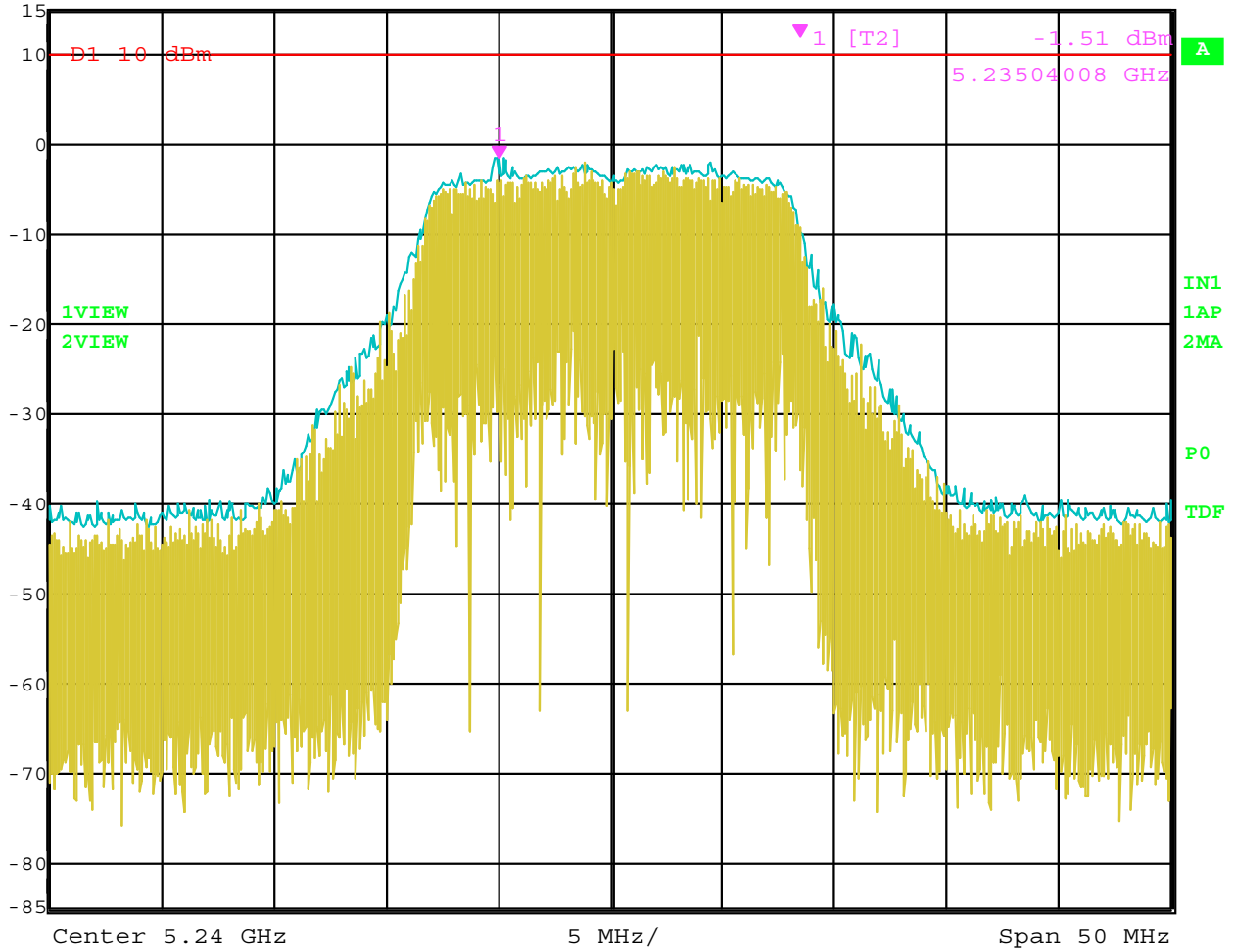

Date: 15.MAR.2005 09:27:52

Peak Power Spectral Density – Channel 48 – UNII Mode – Phycomp Antenna – RSS-210 Method



Ref Lvl 15 dBm
Marker 1 [T2] 4.05 dBm
5.26335671 GHz
RBW 1 MHz RF Att 40 dB
VBW 1 MHz
SWT 5 ms Unit dBm

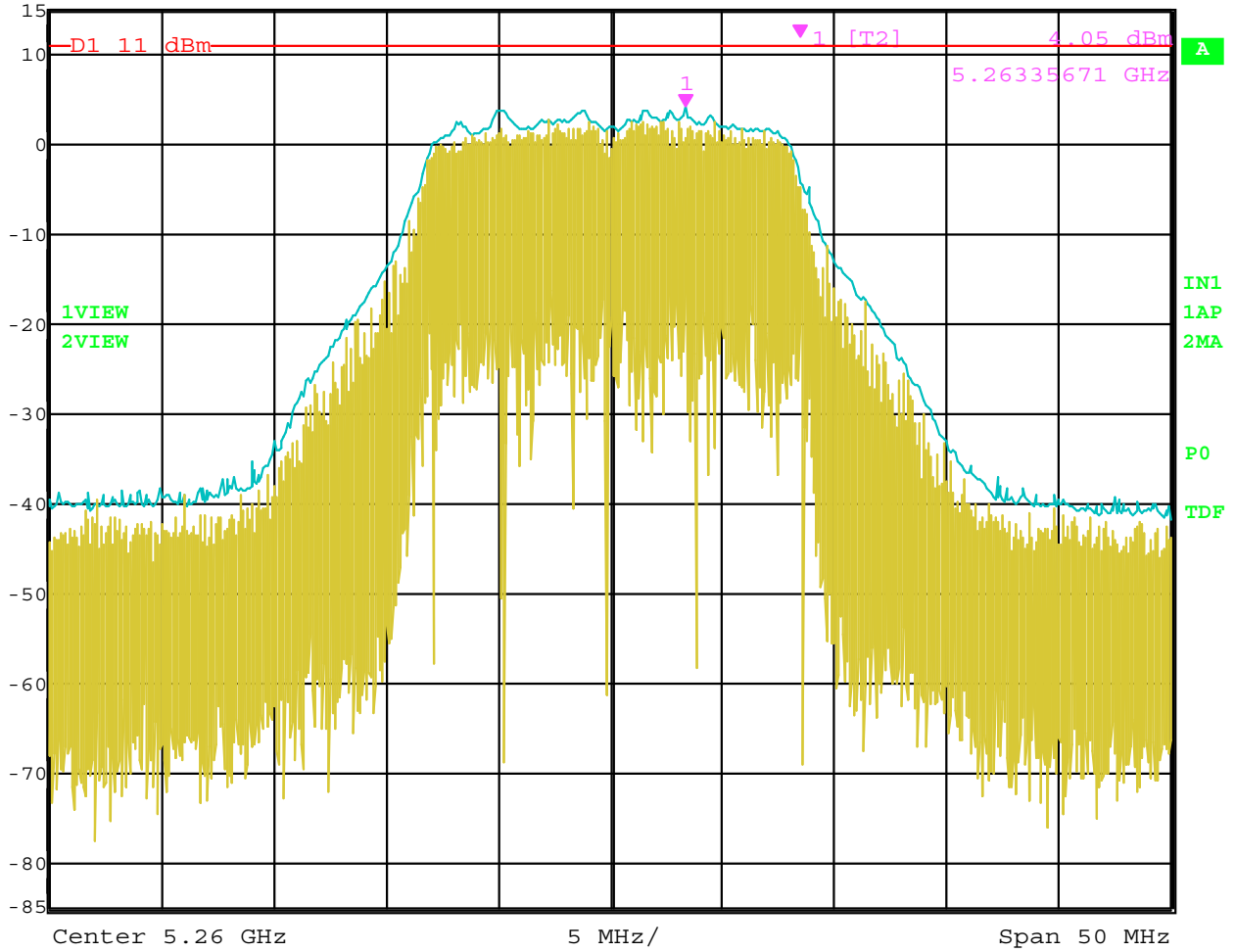

Date: 15.MAR.2005 09:22:46

Peak Power Spectral Density – Channel 52 – UNII Mode – Phycomp Antenna – RSS-210 Method



Marker 1 [T2] RBW 1 MHz RF Att 40 dB
Ref Lvl 3.49 dBm VBW 1 MHz
15 dBm 5.31504008 GHz SWT 5 ms Unit dBm

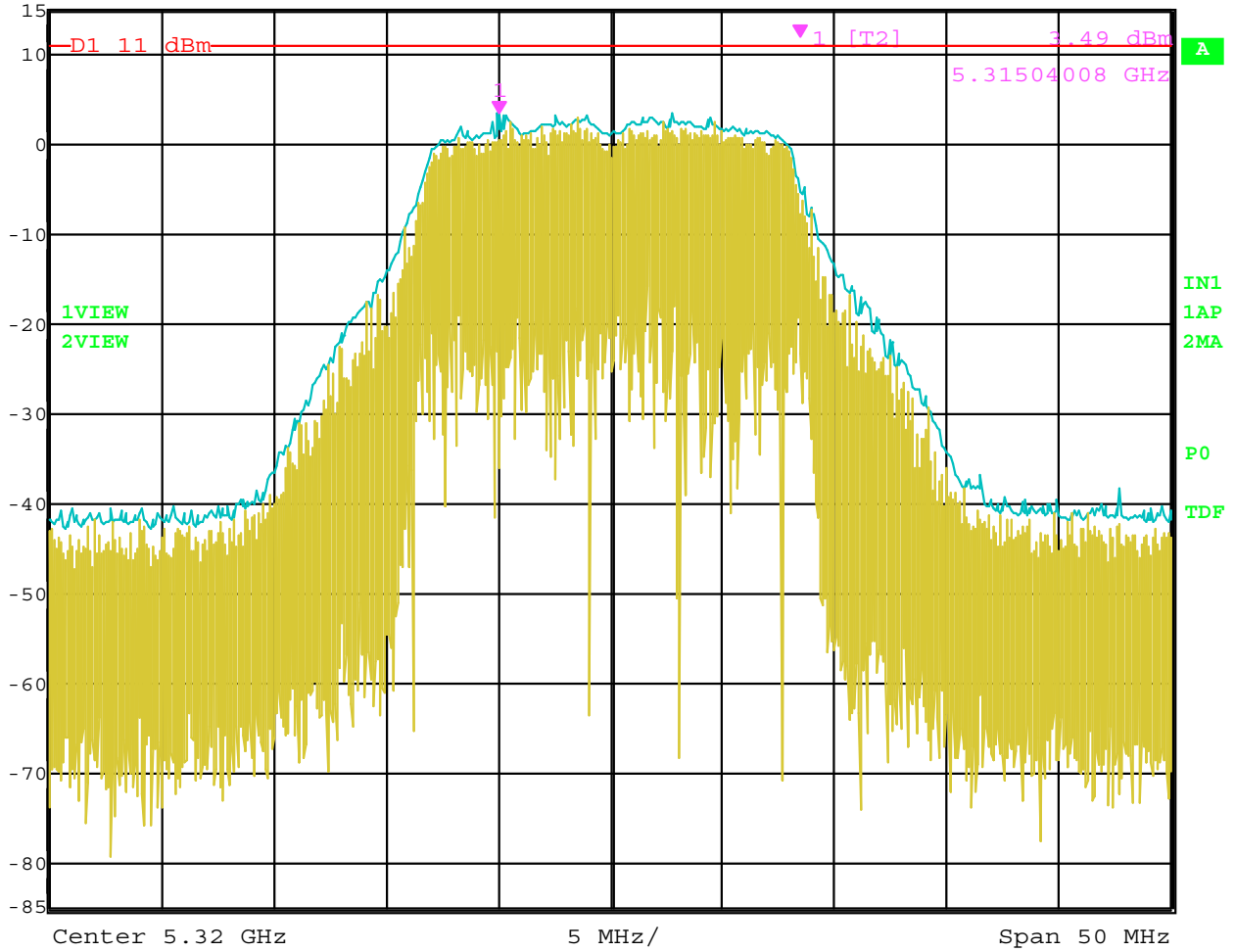

Date: 15.MAR.2005 09:27:05

Peak Power Spectral Density – Channel 64 – UNII Mode – Phycomp Antenna – RSS-210 Method

PEAK EXCURSION

DATA SHEETS



Delta 1 [T2] RBW 1 MHz RF Att 40 dB
Ref Lvl -7.96 dB VBW 30 kHz
15 dBm -100.20040080 kHz SWT 5 ms Unit dBm

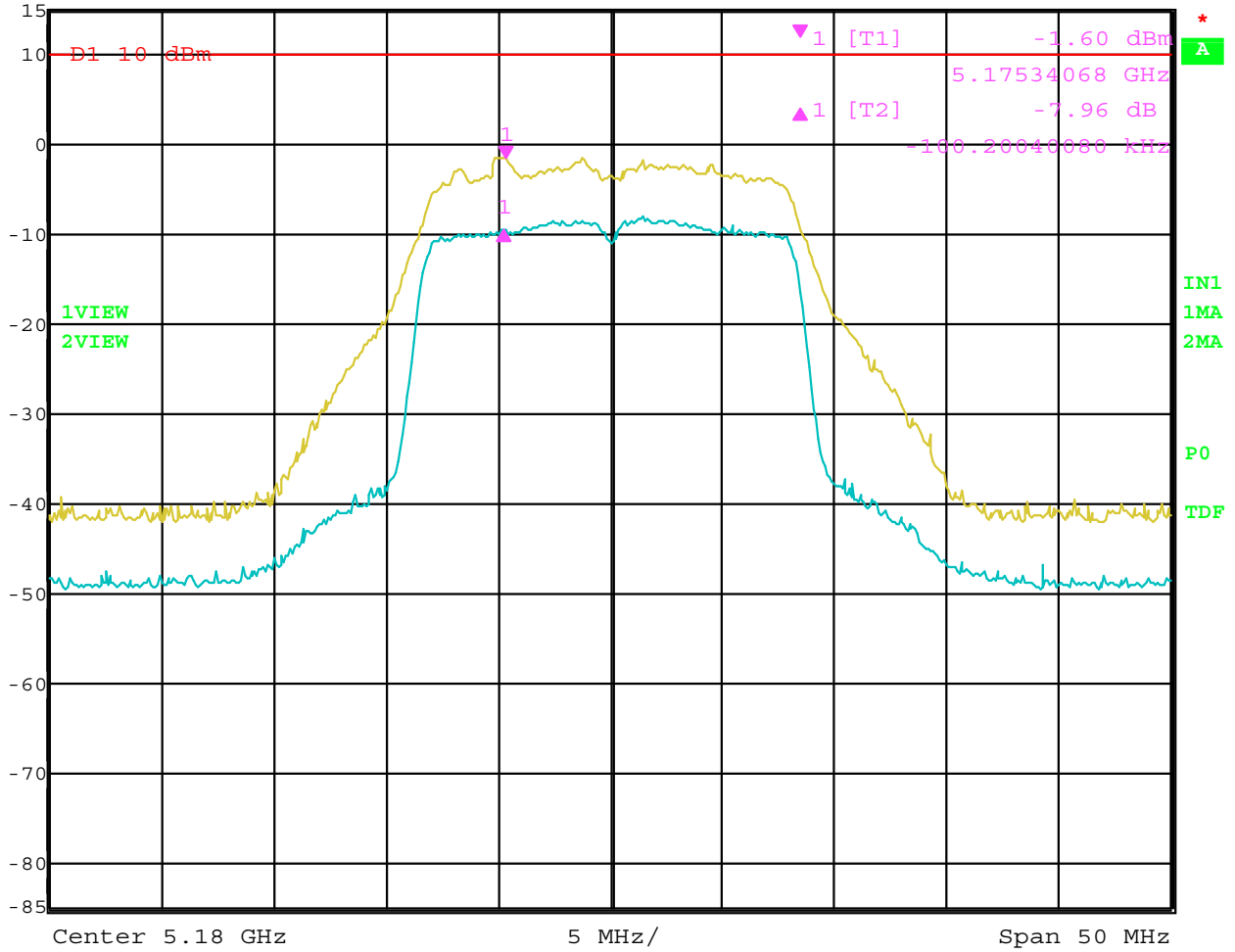

Date: 15.MAR.2005 09:38:56

Peak Excursion – Channel 36 – UNII Mode – Phycomp Antenna



Delta 1 [T2] RBW 1 MHz RF Att 40 dB
Ref Lvl -8.68 dB VBW 30 kHz
15 dBm 0.00000000 Hz SWT 5 ms Unit dBm

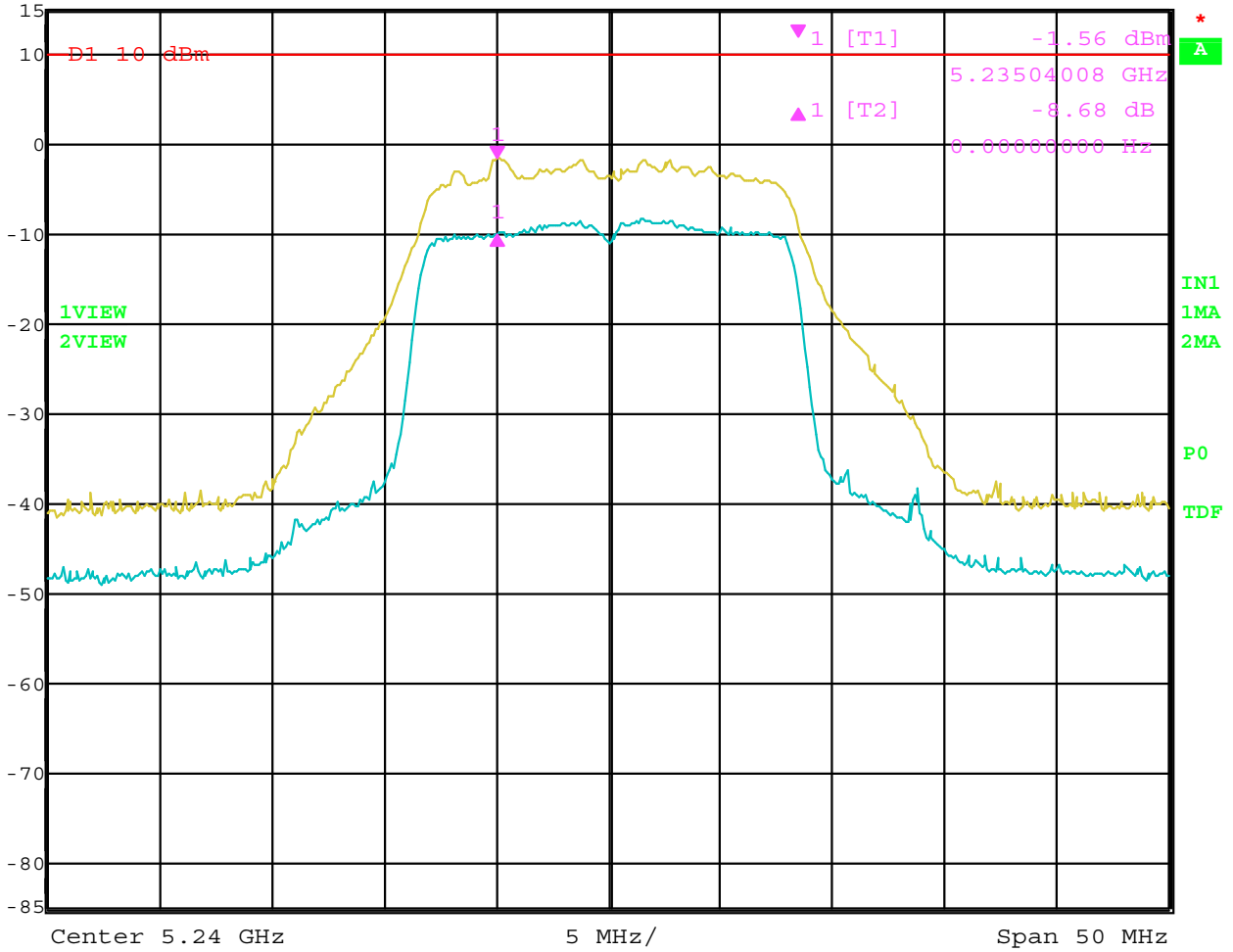

Date: 15.MAR.2005 09:40:42

Peak Excursion – Channel 48 – UNII Mode – Phycomp Antenna



Delta 1 [T2] RBW 1 MHz RF Att 40 dB
Ref Lvl -7.00 dB VBW 30 kHz
15 dBm 0.00000000 Hz SWT 5 ms Unit dBm

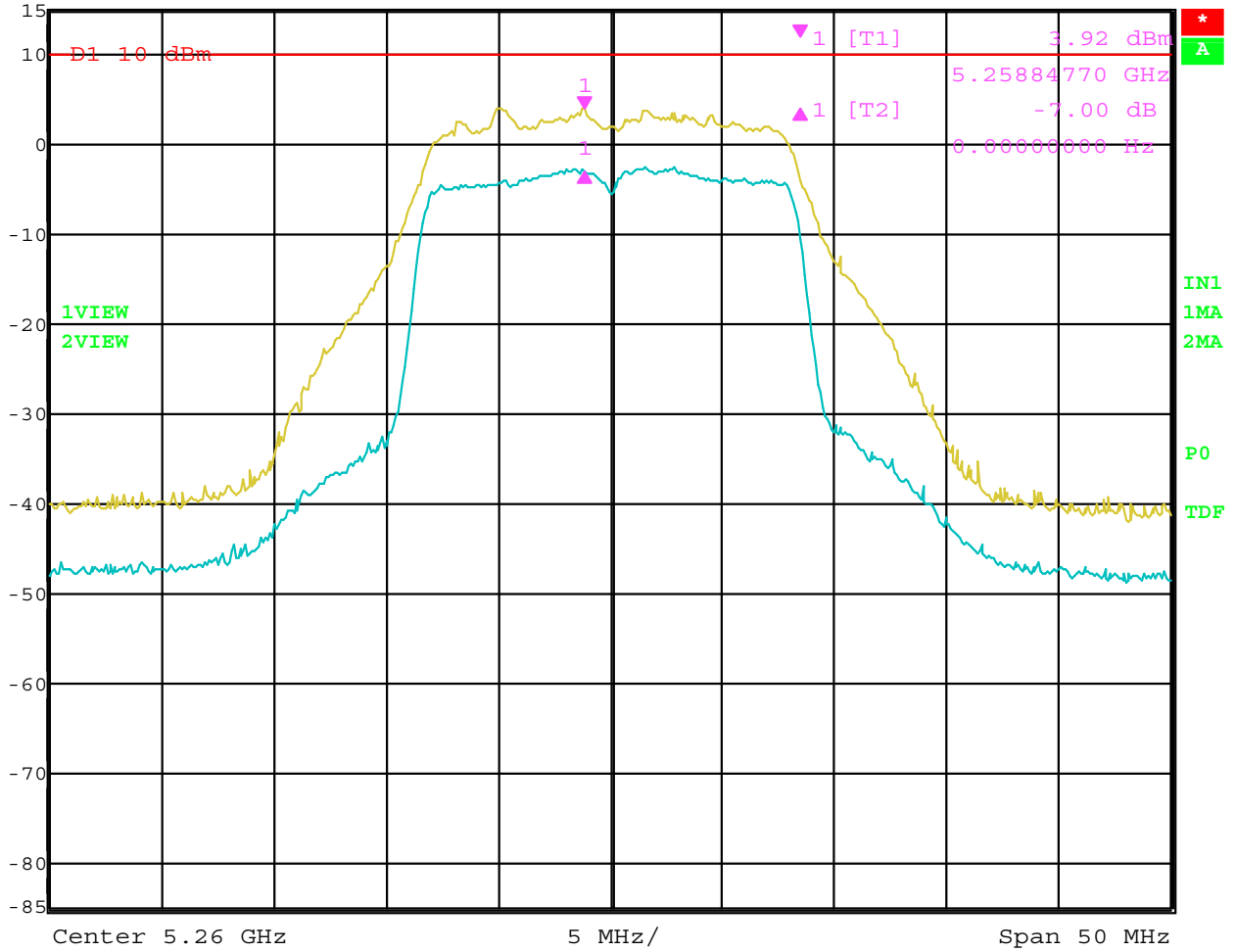

Date: 15.MAR.2005 09:42:29

Peak Excursion – Channel 52 – UNII Mode – Phycomp Antenna



Delta 1 [T2] RBW 1 MHz RF Att 40 dB
Ref Lvl -8.39 dB VBW 30 kHz
15 dBm 0.00000000 Hz SWT 5 ms Unit dBm

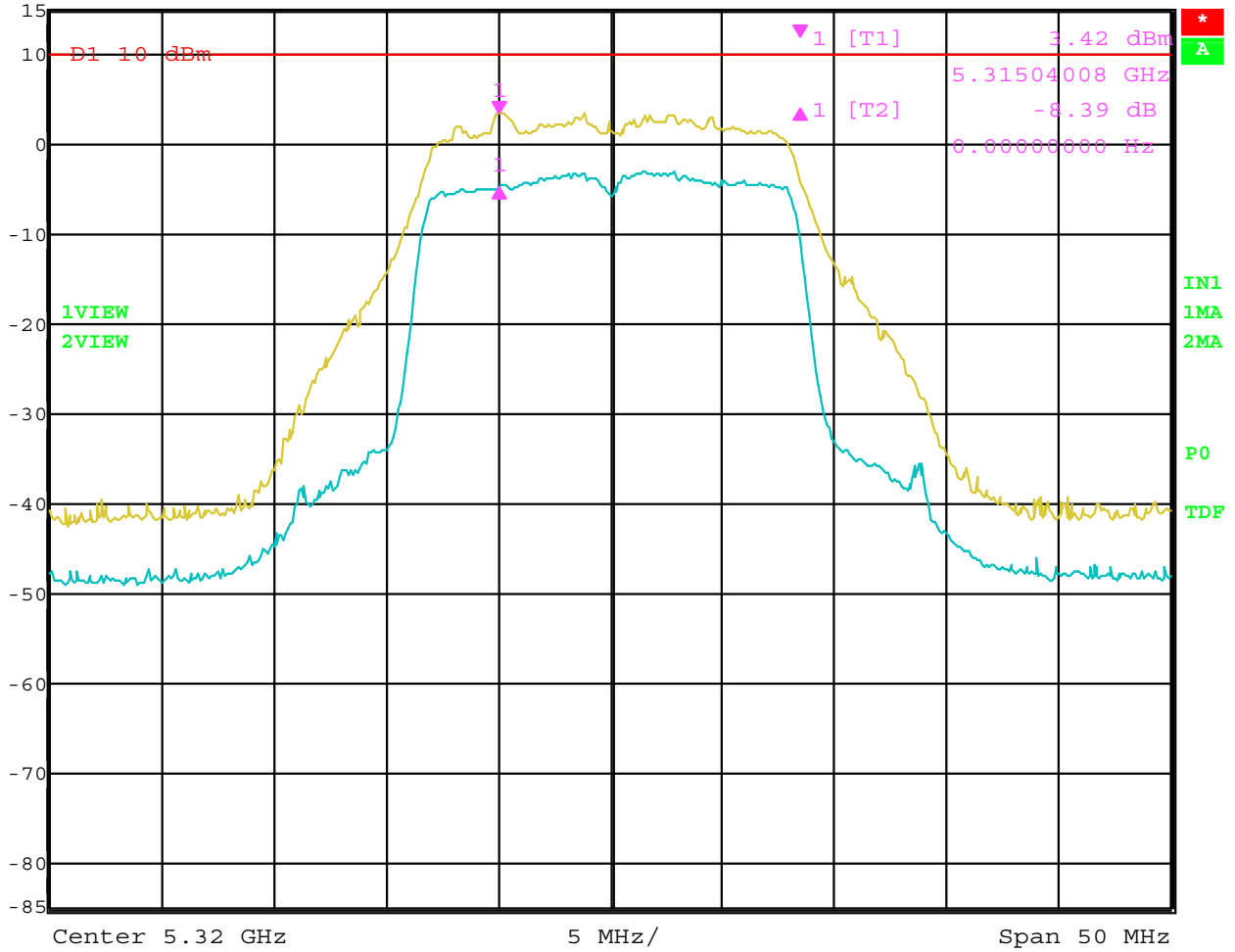

Date: 15.MAR.2005 09:43:52

Peak Excursion – Channel 64 – UNII Mode – Phycomp Antenna

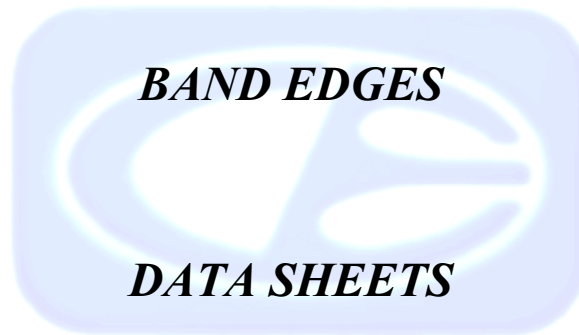

FCC Subpart E

Intel Corporation
 Intel Mini PCI Type 3A 802.11ABG Wireless LAN Adapter
 Model: WM3A2915ABG
 Configuration: Dell Latitude Laptop D510 Agency Series Number: PP17L -- Main Port

Date: 3/15/05
 Lab: B
 Tested By: Kyle Fujimoto

With Phycomp Antenna

Channel 36 - UNII Gain : 1.0 Peak Power: 10.97 dBm Avg. Power: 4.61 dBm
Channel 48 - UNII Gain : 1.5 Peak Power: 10.99 dBm Avg. Power: 4.61 dBm
Channel 52 - UNII Gain : 7.0 Peak Power: 16.16 dBm Avg. Power: 9.74 dBm
Channel 64 - UNII Gain : 7.0 Peak Power: 15.90 dBm Avg. Power: 9.45 dBm
Transmit Mode

Freq. (MHz)	Level (dBuV)	Pol (v/h)	Limit	Margin	Peak / QP / Avg	Ant. Height (m)	Table Angle (deg)	Comments
5180	94.44	V	--	--	Peak	2.22	90	Fundamental - Channel 36
5180	83.95	V	--	--	Avg	2.22	90	Fundamental - Channel 36
5150	49.29	V	74	-24.71	Peak	2.22	90	Band Edge Channel 36
5150	37.97	V	54	-16.03	Avg	2.22	90	Band Edge Channel 36
5240	93.43	V	--	--	Peak	1.02	225	Fundamental - Channel 48
5240	82.74	V	--	--	Avg	1.02	225	Fundamental - Channel 48
5260	98.67	V	--	--	Peak	2.35	225	Fundamental - Channel 52
5260	88.11	V	--	--	Avg.	2.35	225	Fundamental - Channel 52
5320	97.78	V	--	--	Peak	2.71	225	Fundamental - Channel 64
5320	86.72	V	--	--	Avg	2.71	225	Fundamental - Channel 64
5350	51.61	V	74	-22.39	Peak	2.71	225	Band Edge Channel 64
5350	39.19	V	54	-14.81	Avg	2.71	225	Band Edge Channel 64
5390.4	54.75	V	74	-19.25	Peak	2.71	225	Band Edge Channel 64
5430.16	42.65	V	54	-11.35	Avg	2.71	225	Band Edge Channel 64

FCC Subpart E

Intel Corporation
 Intel Mini PCI Type 3A 802.11ABG Wireless LAN Adapter
 Model: WM3A2915ABG
 Configuration: Dell Latitude Laptop D510 Agency Series Number: PP17L -- Main Port

Date: 3/15/05
 Lab: B
 Tested By: Kyle Fujimoto

With Phycomp Antenna

Channel 36 - UNII Gain : 1.0 Peak Power: 10.97 dBm Avg. Power: 4.61 dBm
Channel 48 - UNII Gain : 1.5 Peak Power: 10.99 dBm Avg. Power: 4.61 dBm
Channel 52 - UNII Gain : 7.0 Peak Power: 16.16 dBm Avg. Power: 9.74 dBm
Channel 64 - UNII Gain : 7.0 Peak Power: 15.90 dBm Avg. Power: 9.45 dBm
Transmit Mode

Freq. (MHz)	Level (dBUV)	Pol (v/h)	Limit	Margin	Peak / QP / Avg	Ant. Height (m)	Table Angle (deg)	Comments
5180	96.64	H	--	--	Peak	2.22	90	Fundamental - Channel 36
5180	85.79	H	--	--	Avg	2.22	90	Fundamental - Channel 36
5150	48.91	H	74	-25.09	Peak	2.22	90	Band Edge Channel 36
5150	38.4	H	54	-15.6	Avg	2.22	90	Band Edge Channel 36
5240	96.57	H	--	--	Peak	1.02	225	Fundamental - Channel 48
5240	85.66	H	--	--	Avg	1.02	225	Fundamental - Channel 48
5260	101.5	H	--	--	Peak	2.35	225	Fundamental - Channel 52
5260	91.19	H	--	--	Avg.	2.35	225	Fundamental - Channel 52
5320	100.09	H	--	--	Peak	2.37	0	Fundamental - Channel 64
5320	89.21	H	--	--	Avg	2.37	0	Fundamental - Channel 64
5350	51.67	H	74	-22.33	Peak	2.37	0	Band Edge Channel 64
5350	40.17	H	54	-13.83	Avg	2.37	0	Band Edge Channel 64
5440	56.94	H	74	-17.06	Peak	2.37	0	Band Edge Channel 64
5440.01	44.33	H	54	-9.67	Avg	2.37	0	Band Edge Channel 64



Ref Lvl 110 dB/V
Marker 4 [T2] 37.97 dB/V
5.1500000 GHz
RBW 1 MHz RF Att 20 dB
VBW 10 Hz
SWT 25 s Unit dB/V

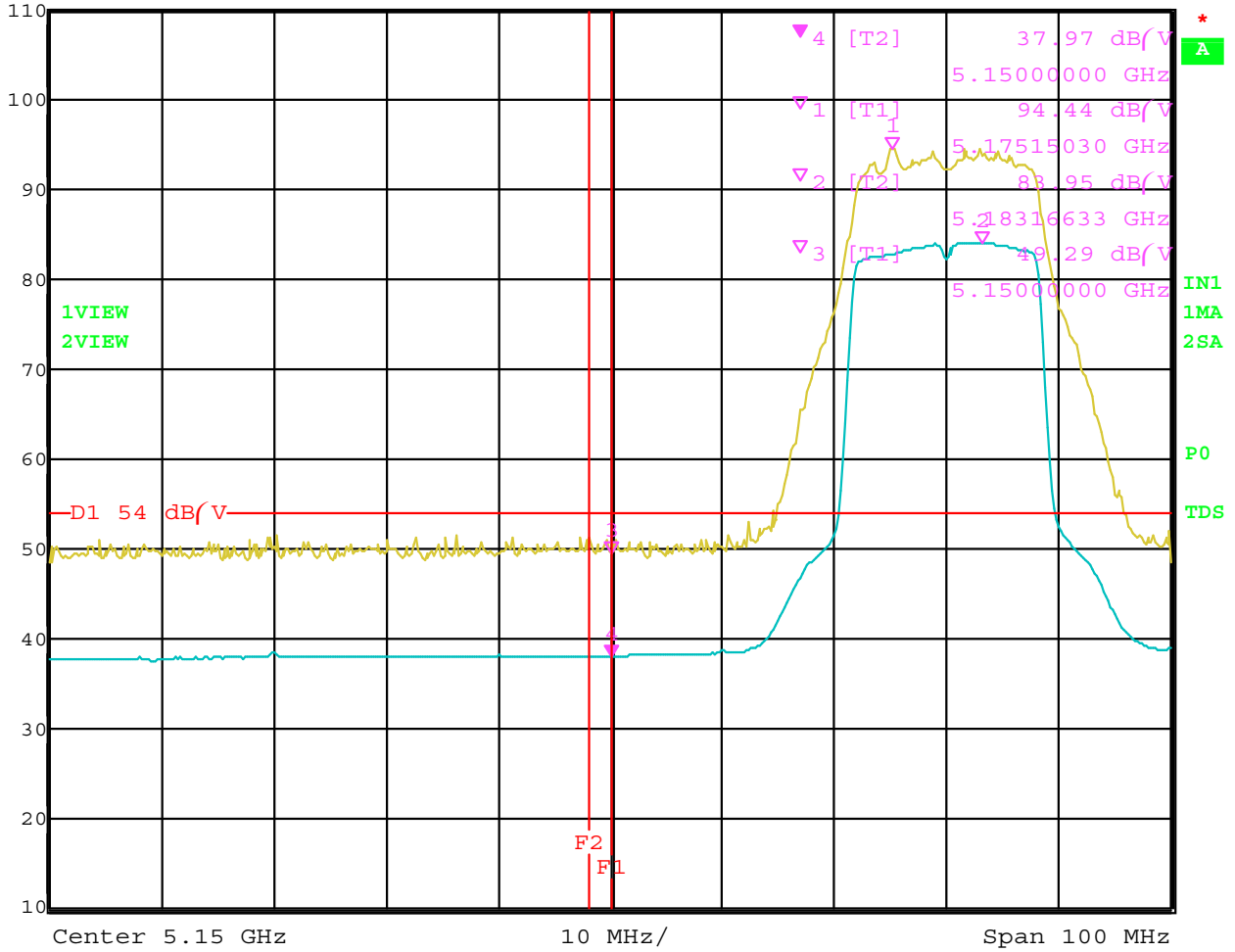

Date: 15.MAR.2005 04:45:05

Band Edge – Channel 36 – Vertical Polarization – UNII Mode – Phycomp Antenna



Ref Lvl 110 dB/V
Marker 4 [T2] 38.40 dB/V
RBW 1 MHz RF Att 20 dB
VBW 10 Hz
SWT 25 s Unit dB/V

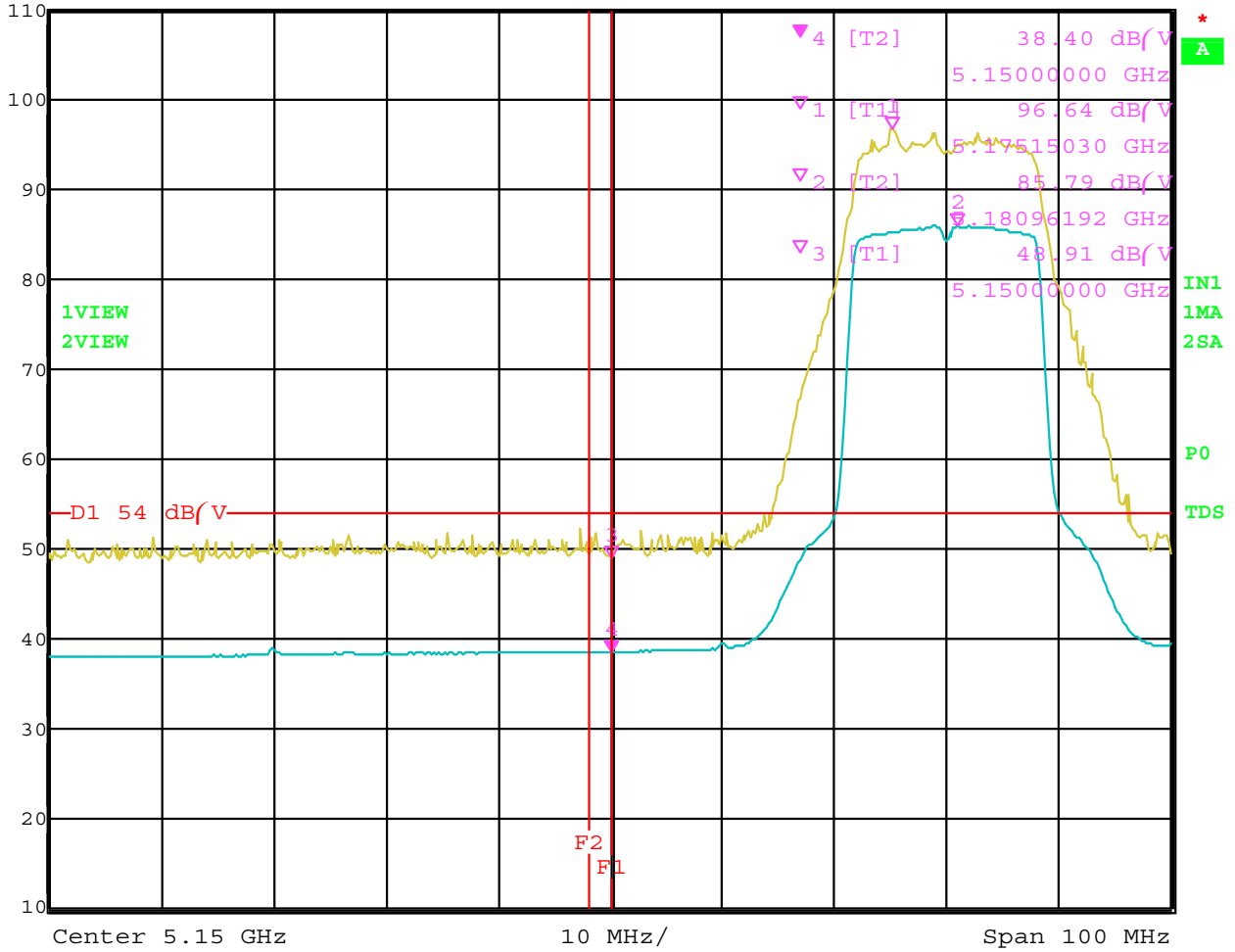

Date: 15.MAR.2005 05:15:22

Band Edge – Channel 36 – Horizontal Polarization – UNII Mode – Phycomp Antenna



Ref Lvl 110 dB/V
 Marker 4 [T2] 42.65 dB/V
 RBW 1 MHz RF Att 20 dB
 VBW 10 Hz
 SWT 40 s Unit dB/V

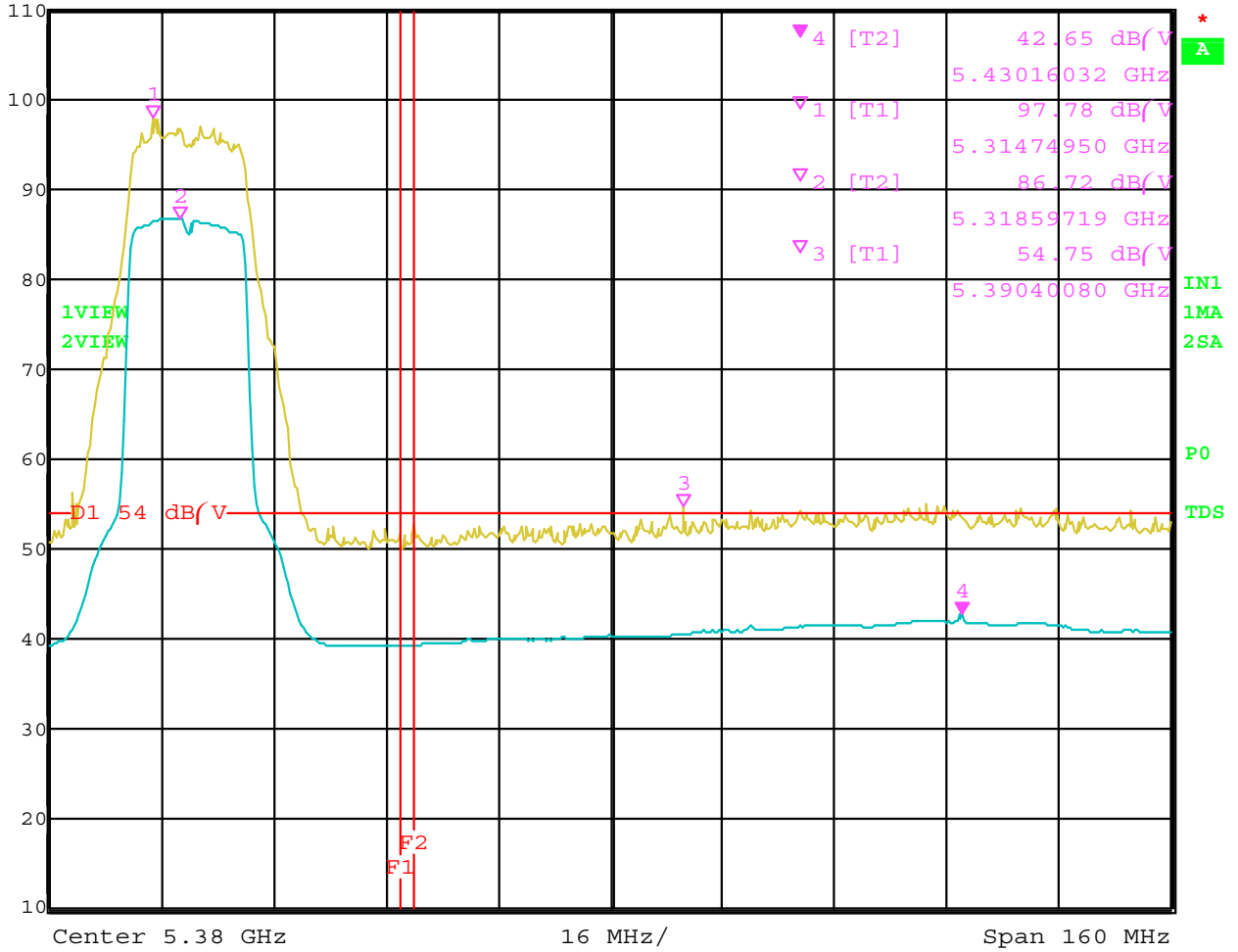

Date: 15.MAR.2005 04:56:20

Band Edge – Channel 64 – Vertical Polarization – UNII Mode – Phycomp Antenna



Ref Lvl 110 dB/V
Marker 4 [T2] 44.33 dB/V
RBW 1 MHz RF Att 20 dB
VBW 10 Hz
SWT 40 s Unit dB/V

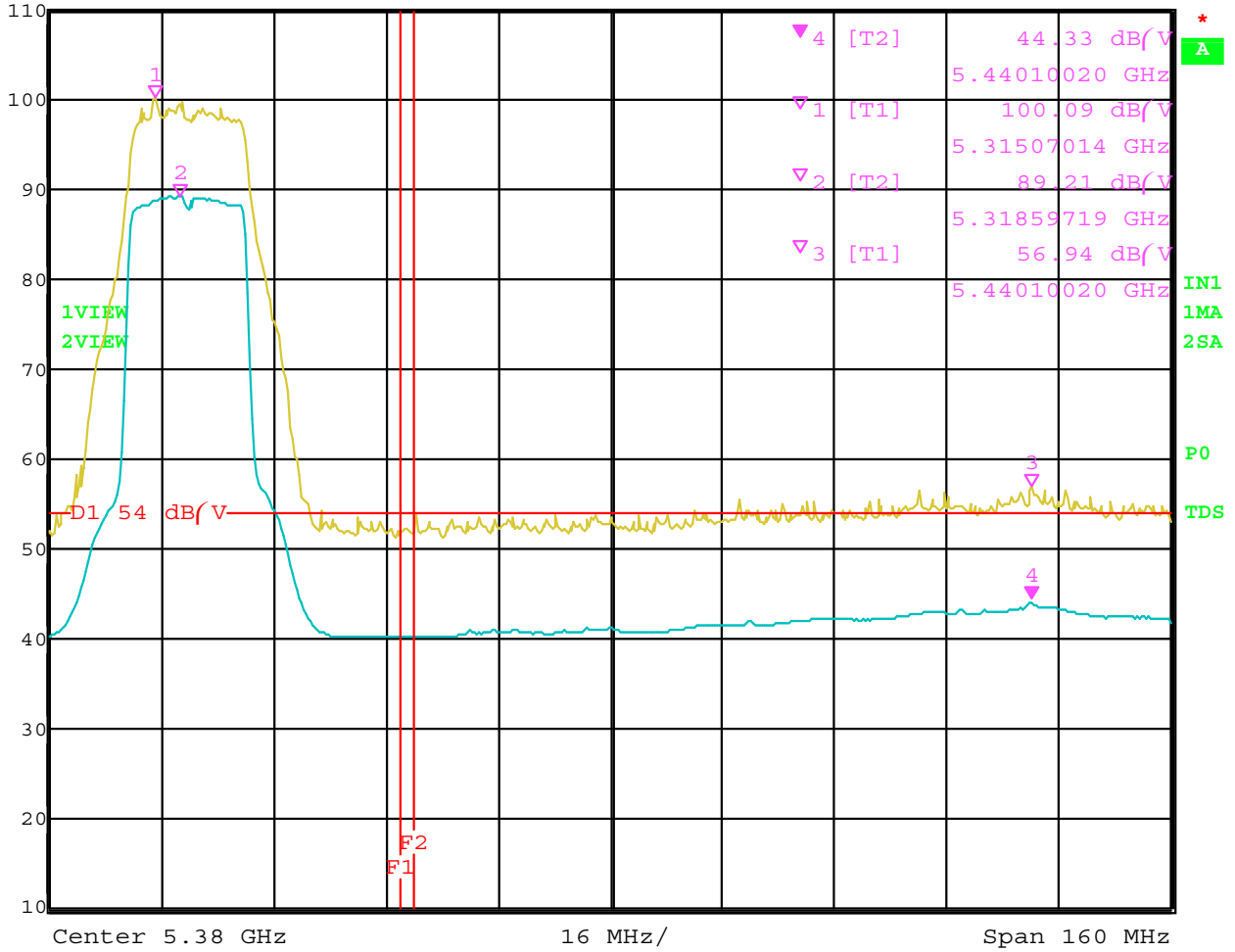

Date: 15.MAR.2005 05:05:16

Band Edge - Channel 64 - Horizontal Polarization - UNII Mode - Phycomp Antenna