



Certification Report on

Specific Absorption Rate (SAR) Hand and Body
Experimental Analysis

Dell Computer Corporation

PP05L

Test Date: December 2003



ITLB-DELL -PP05L-H-802.11BG-MiniPCI-Type3A-4071 REV 2.0

51 Spectrum Way Nepean ON K2R 1E6
Tel: (613) 820-2730 Fax: (613) 820-4161
email: info@aprel.com

Experimental Analysis SAR Report

Subject: **Specific Absorption Rate (SAR) Hand and Body Report**

Product: Dell Laptop With Intel WLAN BG Card

Model: PP05L

Client: Dell Computer Corporation

Applicant: Intel Corporation
Evening Creek Drive,
San Diego CA, 92128

Manufacturer: Dell Computer Corporation

Project #: Dell-PP05L-H-802.11bg-MiniPCI-Type3A-4071
REV.2.0

Prepared by: APREL Laboratories
51 Spectrum Way
Nepean, Ontario
K2R 1E6

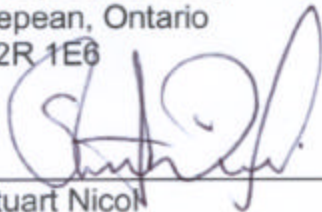

Approved by  Date: 14-JAN-2004
Stuart Nicol
Director Product Development, Dosimetric R&D

Submitted by  Date: Jan. 14, 04
Jay Sarkar
Technical Director of Standards & Certification

Released by  Date: Jan 14 /04
Dr. Jacek J. Wojcik, P. Eng.



Applicant: Intel Corporation
Manufacturer: Dell Computer Corporation
FCC ID: E2K24GBRL
Equipment: Intel Mini PCI Type 3A 802.11BG Wireless LAN Adapter model WM3A2200BG located inside the Dell PP05L laptop
Model: PP05L
Serial Number: 34359471757
Received Status: Production Unit
Standard: FCC 96-326, Guidelines for Evaluating the Environmental Effects of Radio-Frequency Radiation

ENGINEERING SUMMARY

This report contains the results of the engineering evaluation performed on the Intel Mini PCI Type 3A Wireless LAN Adapter model WM3A2200BG located inside a Dell laptop model number PP05L. The analysis was carried out in accordance with the requirements of FCC 96-326, "Guidelines for Evaluating the Environmental Effects of Radio-Frequency Radiation" in accordance with Supplement C and, using methodologies contained within IEEE 1528. The Intel Mini PCI Type 3A Wireless LAN Adapter model WM3A2200BG located inside the Dell laptop was evaluated for compliance to the RF exposure requirements contained in section 2 "Applicable Documents". The card was set to transmit at a **maximum power level of 16.5dBm** (802.11g mode) and a **maximum power level of 17.4 dBm** (802.11b mode) while operating with the **duty cycle set at 100%**.

The Intel Mini PCI Type 3A Wireless LAN Adapter model WM3A2200BG is located inside a Dell laptop model number PP05L and utilizes a Mini PCI type A form factor and has been assessed fully for conservative SAR.

Intel provided APREL laboratories with one production model of the Dell laptop model number PP05L. The Dell laptop can transmit with the LCD open (user mode) and with the LCD closed.

The Dell laptop has an internal set of Hitachi diverse antennas which are located at the top side of the Laptop adjacent with the keyboard, below the hinge. The main transmitting antenna is located at the **TOP Left hand Side of the Laptop below the LCD**.

For the purpose of the SAR analysis executed and subsequent report the Intel Mini PCI Type 3A Wireless LAN Adapter model WM3A2200BG located inside Dell laptop will not be labeled as the DUT (Device Under Test). **The DUT is the Dell laptop model number PP05L.**



The PP05L laptop was evaluated for both body exposure and direct contact SAR (for extremities) at low (ch#1), middle (ch#6) and high (ch#11) for the frequency range of 2412MHz to 2462MHz in both 802.11b and 802.11g mode. Tests were executed at zero mm separation distance, for both direct contact SAR (for extremities) and body SAR analysis.

While working in the **802.11b mode**, the conservative 10g average for direct contact SAR for the DUT was found to be **0.41 W/kg for the peak RF output power of the mid channel (ch#6, f=2437MHz)** at the Left side of the DUT with the LCD closed, with the left side of Laptop facing up against the phantom at 0mm separation. For body SAR analysis the conservative 1 g SAR was found to be **1.17 W/kg for the peak RF output power of the mid channel (ch#6, f=2437MHz)** at the Left side of the DUT with the LCD closed, with the left side of Laptop facing up against the phantom at 0mm separation.

While working in the **802.11g mode**, the conservative 10g average for direct contact SAR for the DUT was found to be **0.35 W/kg for the peak RF output power of the mid channel (ch#6, f=2437MHz)** at the Left side of the DUT with the LCD closed, with the left side of Laptop facing up against the phantom at 0mm separation. For body SAR analysis the conservative 1 g SAR was found to be **0.84 W/kg for the peak RF output power of the mid channel (ch#6, f=2437MHz)** at the Left side of the DUT with the LCD closed, with the left side of Laptop facing up against the phantom at 0mm separation.

Evaluation data and graphs are presented in this report.

For the purpose of the SAR assessment the AC power source was used, and the conservative SAR position and frequency for each of the Test Case Scenarios was reassessed using the battery supply. It was found that the conservative SAR presented in this report was measured while using the AC supply.

Based on the measured results and on how the Dell laptop model number PP50L will be marketed and used, it is certified that the DUT meets the requirements as set forth in the specifications, for the RF exposure environment contained within this report.

The results presented in this report relate only to the sample evaluated.



TABLE OF CONTENTS

ENGINEERING SUMMARY	2
1. Introduction	5
2. Applicable Documents	5
3. Test Case Scenarios.....	6
4. Test Equipment.....	9
4.1 E-010 Isotropic E-Field Probe	10
5. SET Up	11
6. Test Results.....	18
6.1. TRANSMITTER CHARACTERISTICS.....	18
6.2. SAR MEASUREMENTS	19
6.3. DIRECT CONTACT SAR.....	20
6.4. BODY EXPOSURE	21
7. Conclusions	24
Appendix A: Graphic Plots FROM SAR Measurements.....	24
Appendix B: Pictures of the evaluation setup.....	49
Appendix C: Validation Scan.....	56
Appendix D: Uncertainty Budget	59
Appendix E: Probe Calibration Certificate	60
Appendix F: Dipole Calibration Certificate	71



1. INTRODUCTION

Tests were conducted to determine the Specific Absorption Rate (SAR) for a sample Dell laptop model number PP05L. These tests were conducted at APREL Laboratories facility located at 51 Spectrum Way, Nepean, Ontario, Canada.

2. APPLICABLE DOCUMENTS

The following documents are applicable to the evaluation performed:

- 1) FCC 96-326, Guidelines for Evaluating the Environmental Effects of Radio-Frequency Radiation
- 2) ANSI/IEEE C95.1-1999, IEEE Standard for Safety Levels with Respect to Human Exposure to Radio Frequency Electromagnetic Fields, 3 kHz to 300 GHz.
- 3) ANSI/IEEE C95.3-1992, IEEE Recommended Practice for the Measurement of Potentially Hazardous Electromagnetic Fields – RF and Microwave.
- 4) OET Bulletin 65 (Edition 97-01) Supplement C (Edition 01-01), “Evaluating Compliance with FCC Guidelines for Human Exposure to Radio Frequency Electromagnetic Fields”.
- 5) IEEE 1528 “Recommended Practice for Determining the Peak Spatial Average Specific Absorption Rate (SAR) in the Human Body Due to Wireless Communication Devices: Experimental Techniques.”



3. Test Case Scenarios

Intel provided APREL Laboratories with a sample Dell laptop model number PP05L for the purpose of the SAR evaluation. The evaluations performed on the Intel Dell laptop were to establish the conservative SAR value for both 1 and 10g averages while the WM3A2200BG card was transmitting at the maximum power level set below the amplifier saturation point.

Device Tested Laptop Configuration



Dell - PP05L

Device Tested Left Side



Dell-PP05L



Main Antenna Location

Device Tested Top Side

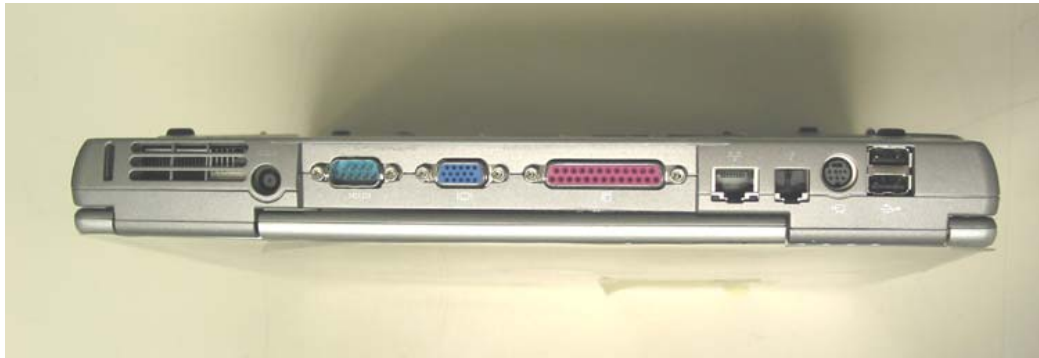

Dell-PP05L



Device Tested Front Side

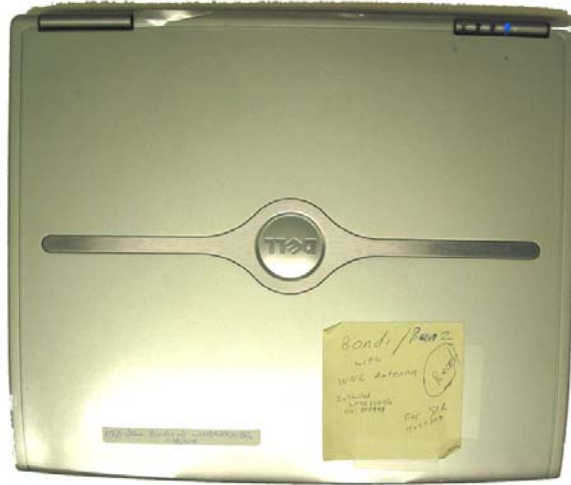

Dell-PP05L

Device Tested Back Side



Dell-PP05L



4. TEST EQUIPMENT

- APREL Triangular Dosimetric Probe Model E-010, s/n 163
- ALIDX-500 Dosimetric SAR Measurement System
- APREL Universal Phantom
- APREL 2.45GHz Dipole
- APREL RF Amplifier
- Hewlett Packard Signal Generator Asset
- Rohde & Schwarz RF Power Meter
- Rohde & Schwarz RF Power Sensor
- Hewlett Packard Dual Directional Coupler

Table 2: Instrumentation

Instrument	Calibration Due	Asset Number/Serial Number
E-010 Probe	May 2004	163
ALIDX-500	March 2004	N/A
APREL Flat Phantom	N/A	APL-001
APREL UniPhantom	N/A	APL-085
APREL 2450MHz Dipole	CBT	N/A
APREL RF Amplifier	CBT	301467
HP-Signal Generator	September 2004	301468
Gigatronics Power Meter	October 2004	301393
Gigatronics RF Power Sensor	October 2004	301394
HP Directional Coupler	October 2004	100251

The APREL Laboratories Device Positioner HE-SET is made from a material which is resistant to solvents referenced in the applicable documents section for this report. In the areas where an antenna or main resonating structure could be located the support is provided with a low density material, similar to Styrofoam.



E-010 Isotropic E-Field Probe

The E-field probe used by APREL Laboratories, has been fully calibrated and assessed for isotropicity, and boundary effect. The probe utilizes a triangular sensor arrangement as detailed in the diagram below.

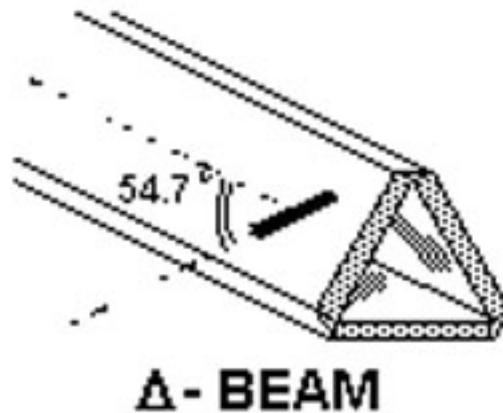

The SAR is assessed with the probe which moves at a default height of 5mm from the centre of the diode, which is mounted to the sensor, to the phantom surface (Z height). The diagram below shows how the centre of the sensor is defined with the location of the diode placed at the centre of the dipole. The 5mm default in the Z axis is the optimum height for assessing SAR where the boundary effect is at it least, with the probe located closest to the phantom surface (boundary).

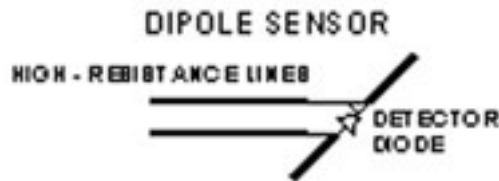

During the cube scan assessment, the probe is positioned in 5 x 8mm steps in both the X, and Y axis, and 7 x 5mm steps for the Z axis. The total size for the physical cube used during the averaging assessment is 32mm x 32mm x 35mm.

5.0 SET UP

5.1 ALIDX-500 Measurement System

The image below shows the laboratory along with the ALIDX-500 Measurement system.



The ALIDX-500 Dosimetric SAR Measurement System was developed jointly with APREL Laboratories and IDX Robotics for use within wireless development and the compliance environment. The system consists of a six axis articulated arm, and controller for precise probe positioning (0.05 mm repeatability). Custom software has been developed to enable communications between the robot controller software and the host operating system.

An amplifier is located on the articulated arm, which is isolated from the custom designed end effector and robot arm. The end effector provides the mechanical touch detection functionality and probe connection interface. The amplifier is functionally validated within the manufacturer's site and calibrated at NCL Calibration Laboratories. A Data Acquisition Card (DAC) is used to collect the signal as detected by the isotropic e-field probe. The DAC manufacturer calibrates the DAC to NIST standards. A formal validation is executed using all mechanical and electronic components to prove conformity of the measurement platform as a whole.

The ALIDX-500 has been designed to measure devices within the compliance environment to meet all recognized standards. The system also conforms to standards, which are currently being developed by the scientific and manufacturing community.

The course scan resolution is defined by the operator and reflects the requirements of the standard to which the device is being tested. Precise measurements are made within the predefined course scan area and the values are logged.

The user predefines the sample rate for which the measurements are made so as to ensure that the full duty-cycle of a pulse modulation device is covered during the sample. The following algorithm is an example of the function used by the system for linearization of the output for the probe.

$$V_i = U_i + U_i^2 \cdot \frac{cf}{dcp_i}$$

The APREL E-Field probe is evaluated to establish the diode compression point.

A complex algorithm is then used to calculate the values within the measured points down to a resolution of 1mm. The data from this process is then used to provide the co-ordinates from which the cube scan is created for the determination of the 1 g and 10 g averages.



Cube scan averaging consists of a number of complex algorithms, which are used to calculate the one, and ten gram averages. The basis for the cube scan process is centered on the location where the maximum measured SAR value was found. When a secondary peak value is found which is within 60% of the initial peak value, the system will report this back to the operator who can then assess the need for further analysis of both the peak values prior to the one and ten-gram cube scan averaging process. The algorithm consists of 3D cubic Spline, and Lagrange extrapolation to the surface, which form the matrix for calculating the measurement output for the one and ten gram average values. The resolution for the physical scan integral is user defined with a final calculated resolution down to 1mm.

In-depth analysis for the differential of the physical scanning resolution for the cube scan analysis has been carried out, to identify the optimum setting for the probe positioning steps, and this has been determined at 8mm increments on the X, & Y planes. The reduction of the physical step increment increased the time taken for analysis but did not provide a better uncertainty or return on measured values.

Prior to the measurement process the operator can insert the parameters for which the physical measurements are made, defining the X, Y, and Z probe movement integrals. For the FCC compliance process both OET 65 “Supplement C” and the IEEE 1528 were used to define the measurement parameters used during the assessment of the device.

The final output from the system provides data for the area scan measurements, physical and splined (1mm resolution) cube scan with physical and calculated values (1mm resolution).

The overall uncertainty for the methodology and algorithms the ALIDX500 used during the SAR calculation was evaluated using the data from IEEE 1528 f3 algorithm:

$$f_3(x, y, z) = A \frac{a^2}{\frac{a^2}{4} + x'^2 + y'^2} \cdot \left(e^{-\frac{2z}{a}} + \frac{a^2}{2(a + 2z)^2} \right)$$

The probe used during the measurement process has been assessed to provide values for diode compression. These values are calculated during the probe calibration exercise and are used in the mathematical calculations for the assessment of SAR.

5.2 Validation

A full system validation was run prior to the SAR testing. The methodology used for the system validation was taken from IEEE 1528 section 7 (where applicable). Further details of the tissue used during the system validation are provided in section 6.3 Simulated Tissue. The results from the system validation are provided in Appendix C Validation Results.

The image below shows the setup used for the system validation.



IEEE 1528 is a standard specific to wireless handset evaluations, primarily used for voice communications. Not all of IEEE 1528 standard is applicable to the testing performed. Applicable sections relate to calibration for probes, specifications for dipoles, probes etc, validation methodologies used for the system verification, tissue calibration processes and the uncertainty budget assigned for each specific measurement.

NOTE:

The full analysis of the Device as tested was completed within a 24hr period.

5.3 Body & Bystander Analysis

Measurements were made on the DUT while it was operating in the standard laptop configuration and while the LCD was closed. The device was assessed for both body and direct contact SAR at the low, mid and, high frequency channel settings. A full assessment was made for the device using the laptop configuration, with the top of the LCD, being assessed, along with the DUT being positioned vertically and assessments made on the left and right hand side.

The image below shows part of the setup used for body measurements.

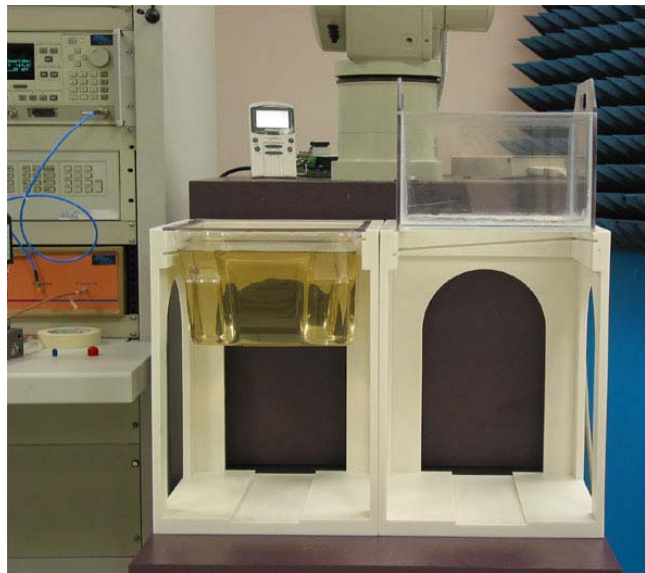

5.4 Simulated Tissue

The recipes used to make the simulated tissue were based on those as presented in OET Supplement C for body at 2450MHz and is provided below in table 3.

Table 3: Ingredients used for tissue

INGREDIENT	2450 MHz
DGBE	26.76 %
Water	73.2 %
Salt	0.04
Dielectric Constant	52.7
Conductivity (S/m)	1.95

The density used to determine SAR from the measurements was the recommended 1.0 kg/m³ found in Appendix C of “Supplement C OET Bulletin 65, Edition 01-01”.

Dielectric parameters of the simulated tissue material were determined using an Anritsu 37347A Vector Network Analyzer, and the APREL Dielectric Probe.

For the system validation the tissue was calibrated at 2450 MHz.

Table 4: Validation executed 17th December 03

BODY Tissue	APREL	Target Value	Δ (%)
Dielectric constant, ϵ_r	50.6	52.7	-4.0
Conductivity, σ [S/m]	2.03	1.95	+4.1

Tissue Conversion Factor,	6.6
Tissue Temperature (°C)	22.0
Ambient Temperature (°C)	23.0

Table 5: Tissue Calibration Instrumentation

Instrument	Calibration Due	Asset Number/Serial Number
Anritsu VNA	CBT	301382
APREL Dielectric Probe	CBT	-

5.5 Methodology

1. The test methodology utilized in the analysis of the Test Case Scenarios complies with the requirements of FCC 96-326 and ANSI/IEEE C95.3-1992.
2. The E-field is measured with a small isotropic probe (output voltage proportional to E^2).

$$SAR = \frac{\sigma |E|^2}{\rho}$$

3. The probe is moved precisely from one point to the next using the robot (10 mm increments for wide area scanning and 8 mm increments for zoom scanning in the X, Y directions) and (5.0 mm increments for the final depth profile measurement in the Z direction).
4. The probe travels in the homogeneous liquid simulating human tissue (body).

Section 5.4 contains information about the properties of the simulated tissue used for these measurements.

5. The liquid is contained in a manikin simulating a portion of the human body with an overall shell thickness of 2 mm.
6. The DUT is positioned with the surface under investigation against the phantom with no separation distance for an initial conservative analysis.
7. All tests were performed with the highest power available from the sample DUT under transmit conditions.

More detailed descriptions of the test method are given in Section 6 where appropriate.

6.0 TEST RESULTS

6.1 TRANSMITTER CHARACTERISTICS

The Intel Mini PCI Type 3A 802.11BG Wireless LAN Adapter model WM3A2200BG was integrated by Intel. It was then set to transmit, using the software, which was supplied by Intel, in both 802.11b and 802.11g modes with a 100% duty cycle (modulated mode).

The Dell laptop PP05L has been developed to operate with both the AC and battery cell. The DUT was analyzed and conducted power measurements were made on the Tx output port for the Mini PCI card using both battery and AC supply. The power measurement exercise showed that **no measurable difference could be made** (within a 40 minute period) when comparing battery and AC power modes.

The DUT then had the conducted power measured before and after SAR scanning while transmitting using the AC supply. These power measurements were made to assess any measurable drift. Table six contains the results from this exercise.

Note

The power measurements taken were conducted and measured using a power meter, and broadband power sensor.

Table 6: Conducted power measurement before and after the scanning

Type of Exposure	Work Mode	Scan Type Equivalent	Power Readings (dBm)		ΔP_{TX} (dB)
			Before scanning	After scanning	
Direct Contact Exposure	802.11b	Area	17.4	17.4	0
		Zoom	17.4	17.4	0
	802.11g	Area	16.5	16.5	0
		Zoom	16.5	16.5	0
Body Exposure	802.11b	Area	17.4	17.4	0
		Zoom	17.4	17.4	0
	802.11g	Area	16.5	16.5	0
		Zoom	16.5	16.5	0



6.2 SAR MEASUREMENTS

- 1) RF exposure is expressed as Specific Absorption Rate (SAR). SAR is calculated from the E-field, measured in a grid of test points. SAR is expressed as RF power per kilogram of mass, averaged in 10 grams of tissue for the extremities and 1 gram of tissue elsewhere. The equation below is a representation of how SAR can theoretically equate.

$$SAR = \frac{d}{dt} \left(\frac{dW}{dm} \right) = \frac{d}{dt} \left(\frac{dW}{\rho dV} \right)$$

- 2) The DUT was put into test mode for the SAR measurements via test software supplied by the manufacturer running on the host platform. This control software set the DUT channel and operating TX mode/frequency.
- 3) Table 6, provides the details in tabular form of the full measurement analysis (Test Case Scenarios), which was performed on the DUT. Appendix A provides contour plots of the SAR measurements super imposed on the DUT.
- 4) Zoom scans were performed for the low, middle and high channels of the DUT. These scans were repeated for all the required positions of the DUT. The DUT was operating with maximum output power and a duty cycle of 100%. The DUT was placed up against the phantom during the test process. The phantom shell thickness is 2 mm overall.

6.3 DIRECT CONTACT SAR

All subsequent testing for the direct contact SAR was performed on three channels (low: 2412MHz, middle: 2437MHz, high: 2462MHz) at the normal laptop use position and with the LCD closed. The results are presented in table 7.

- 1) The device had an initial area scan executed to establish the location of the maximum peak SAR. A calculated resolution of 1 mm was used to determine the location for the peak SAR.
- 2) The device was then explored on a refined 32 mm grid (Cube, Zoom Scan) in three dimensions (X, Y & Z) measuring at 8 mm integrals X & Y and 5 mm integrals in the Z plane so as to create a physical measured point matrix. The system then runs a series of complex algorithms, which completes the matrix of calculated and measured values equivalent to a 1 mm resolution in the X, & Y planes.
- 3) The software runs a series of Lagrange functions to provide the data for the Z plane, which is inserted into the matrix.
- 4) To complete the calculated matrix (1 mm resolution) a fourth-order polynomial extrapolation is used to compute the surface values and the 1 and 10-gram averages are then calculated.
- 5) Where two (or more) peaks with similar values are measured the location of the peaks is recorded. A refined grid is then created to assess each peak location individually, and the maximum value from the assessment is used to record conservative SAR for this report.
- 6) While working under **802.11b** mode, the highest conservative SAR value averaged over 10 grams for the direct contact exposure analysis (**DUT Left Side**) was found to be 0.41 W/kg at the mid channel 2437MHz.
- 7) While working under **802.11g** mode, the highest conservative SAR value averaged over 10 grams for the direct contact exposure analysis (**DUT Left Side**) was found to be 0.35 W/kg at the mid channel 2437MHz.

6.4 BODY EXPOSURE

All subsequent testing for body exposure SAR was performed on three channels (low: 2412MHz, middle: 2437MHz, high: 2462MHz) at the normal laptop use position and with the LCD closed.

- 1) The device had an initial area scan executed to establish the location of the maximum peak SAR. A calculated resolution of 1mm was used to determine the location for the peak SAR.
- 2) The device was then explored on a refined 32 mm grid (Cube, Fine Scan) in three dimensions (X, Y & Z) measuring at 8 mm integrals X & Y and 5 mm integrals in the Z plane so as to create a physical measured point matrix. The system then runs a series of complex algorithms, which completes the matrix of calculated and measured values equivalent to a 1 mm resolution in the X, & Y planes.
- 3) The software runs a series of Lagrange functions to provide the data for the Z plane, which is inserted into the matrix.
- 4) To complete the calculated matrix (1mm resolution) a fourth order polynomial is used to extrapolate the surface values and the 1 and 10-gram averages are then calculated.
- 5) Where two (or more) peaks with similar values are measured the location of the peaks is recorded. A refined grid is then created to assess each peak location individually, and the maximum value from the assessment is used to record conservative SAR for this report.
- 6) While working under **802.11b** mode, the highest conservative SAR value averaged over 1 grams for the body exposure analysis (**DUT Left Side**) was found to be 1.17 W/kg at the mid channel 2437MHz.
- 7) While working under **802.11g** mode, the highest conservative SAR value averaged over 1 grams for the body exposure analysis (**DUT Left Side**) was found to be 0.84 W/kg at the mid channel 2437MHz.



Table 7a Test Results under 802.11b mode

1 g and 10 g SAR values for the Dell PP05L and Intel Mini PCI Type 3A 802.11BG Wireless LAN Adapter model WM3A2200BG

SAR Type	Position Separation mm	Channel	Channel Number	Freq MHz	1g SAR W/kg	10g SAR W/kg
Direct	DUT Left Side	Low	1	2412	-	0.40
Direct	DUT Left Side	Mid	6	2437	-	0.41
Direct	DUT Left Side	High	11	2462	-	0.39
Body	DUT Left Side	Low	1	2412	1.03	-
Body	DUT Left Side	Mid	6	2437	1.17	-
Body	DUT Left Side	High	11	2462	1.05	-
Direct	DUT Top LHS	Mid	6	2437	-	0.23
Body	DUT Top LHS	Mid	6	2437	0.56	-
Direct	DUT Front Side	Mid	6	2437	-	0.09
Body	DUT Front Side	Mid	6	2437	0.27	-
Direct	DUT Back Side	Mid	6	2437	-	0.07
Body	DUT Back Side	Mid	6	2437	0.15	-

All Tests Executed 17th December 03



Table 7b Test Results under 802.11g mode

1 g and 10 g SAR values for the Dell PP05L and Intel Mini PCI Type 3A 802.11BG Wireless LAN Adapter model WM3A2200BG

SAR Type	Position Separation mm	Channel	Channel Number	Freq MHz	1g SAR W/kg	10g SAR W/kg
Direct	DUT Left Side	Low	1	2412	-	0.32
Direct	DUT Left Side	Mid	6	2437	-	0.35
Direct	DUT Left Side	High	11	2462	-	0.30
Body	DUT Left Side	Low	1	2412	0.73	-
Body	DUT Left Side	Mid	6	2437	0.84	-
Body	DUT Left Side	High	11	2462	0.70	-
Direct	DUT Top LHS	Mid	6	2437	-	0.14
Body	DUT Top LHS	Mid	6	2437	0.38	-
Direct	DUT Front Side	Mid	6	2437	-	0.07
Body	DUT Front Side	Mid	6	2437	0.16	-
Direct	DUT Back Side	Mid	6	2437	-	0.06
Body	DUT Back Side	Mid	6	2437	0.13	-

All Tests Executed 17th December 03



7. CONCLUSIONS

The maximum Specific Absorption Rate (SAR) averaged over 10 grams, was found to be **at the Left Side of DUT operating with 802.11b mode**, where the conservative SAR was measured on the **Mid channel 2437MHz at 0.41 W/kg** (direct contact SAR for the exposed extremities – hands, wrists, feet and ankles). The overall margin of uncertainty for this measurement is **±17.8%** (Appendix D).

SAR Limit Direct Contact	Conservative Measured SAR
4.0 W/kg 10 gram Average Maximum	0.41 W/kg 10 gram Average

The maximum Specific Absorption Rate (SAR) averaged over 1 gram, was found to be **at the Left Side of DUT operating with 802.11b mode**, where the conservative SAR was measured on the **Mid channel 2437MHz at 1.17 W/kg** (Body SAR). The overall margin of uncertainty for this measurement is **±18.0%** (Appendix D).

SAR Limit Body	Conservative Measured SAR
1.6 W/kg 1 gram Average Maximum	1.17 W/kg 1 gram Average

Considering the above, this unit as tested, and as it will be marketed and used, is found to be compliant with the FCC 96-326 requirements.



Tested by: Yingchi Chen
Y. Chen

Date: 17th December, 2003



Appendix A

TEST GRAPHIC PLOTS



Graph 1a

Direct contact SAR (10g)
 DUI Left Side
 Distance 0 mm
 Mid Channel
 Frequency: 2437 MHz
 Mode: 802.11b

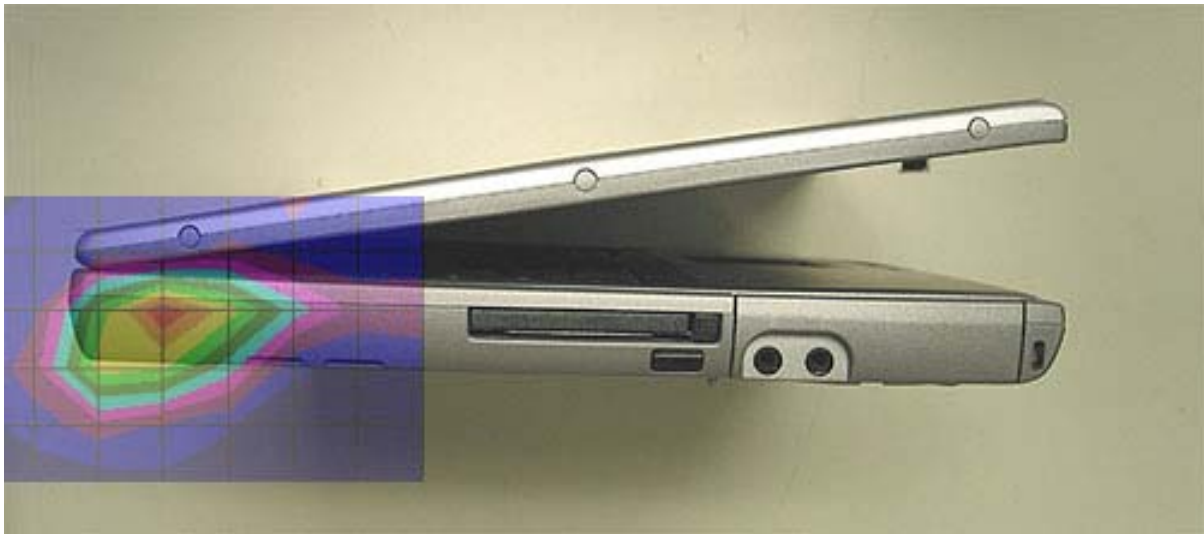

Date	Dielectric Constant ϵ_r	Conductivity σ [S/m]	Probe Con/F	Tissue Temp (°C)	10g SAR (W/kg)	Power Drift
17/12/03	50.6	2.03	6.6	22.0	0.41	0



Graph 1b

Body SAR (1g)
 DUI Left Side
 Distance 0 mm
 Mid Channel
 Frequency: 2437 MHz
 Mode: 802.11b

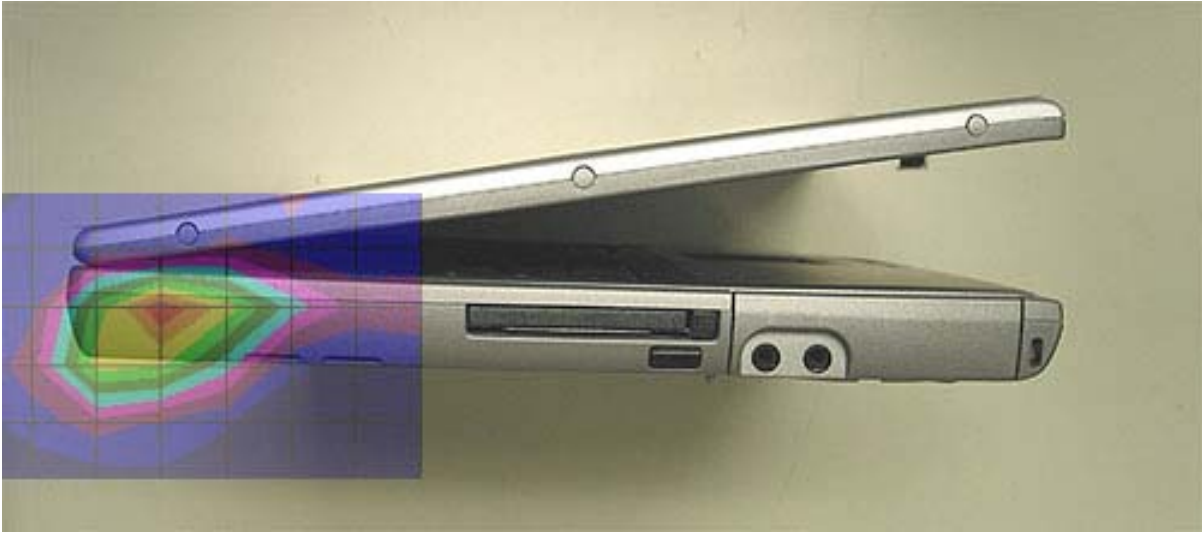

Date	Dielectric Constant ϵ_r	Conductivity σ [S/m]	Probe Con/F	Tissue Temp (°C)	1g SAR (W/kg)	Power Drift
17/12/03	50.6	2.03	6.6	22.0	1.17	0



SAR Data Report

SAR Data Report BENZ-BONDI_left_2412_b

Start : 17-Dec-03 03:17:14 pm
End : 17-Dec-03 03:22:56 pm
Code Version : 4.12
Robot Version: 4.08

Product Data:

Type : BENZ-BONDI
Frequency : 2437 MHz
Antenna Type : Center Fed
Antenna Posn. : Internal

Measurement Data:

Phantom Name : Uni-Dell
Phantom Type : Uniphantom
Tissue Type : Muscle
Tissue Dielectric : 50.600
Tissue Conductivity : 2.030
Tissue Density : 1.000
Crest Factor : 1.000
Robot Name : CRS

Probe Data:

Probe Name : 163
Probe Type : E Fld Triangle
Frequency : 2450 MHz
Tissue Type : Muscle
Calibrated Dielectric : 50.600
Calibrated Conductivity : 2.030
Probe Offset : 2.500 mm
Conversion Factor : 8.500
Diode Compression Pt : 76.0 mV
Probe Sensitivity : 0.580 0.580 0.580 mV/(mW/cm²)
Amplifier Gains : 20.00 20.00 20.00
Chan. Offset (mV) : -4.91 3.16 -0.53

Sample:

Rate: 6000 Samples/Sec
Count: 1000 Samples
NIDAQ Gain: 5
Scan Time: 166.7 msec

Comments:

Area Scan - Max Local SAR Value at x=12.0 y=-25.0 = 0.80 W/kg

Zoom Scan - Max Local SAR Value at x=15.0 y=-26.0 z=0.0 = 2.93 W/kg

Max 1g SAR at x=14.0 y=-27.0 z=0.0 = 1.17 W/kg

Max 10g SAR at x=13.0 y=-27.0 z=0.0 = 0.41 W/kg



Z Axis Scan

SAR - Z Axis
at Hotspot x:15.0 y:-26.0

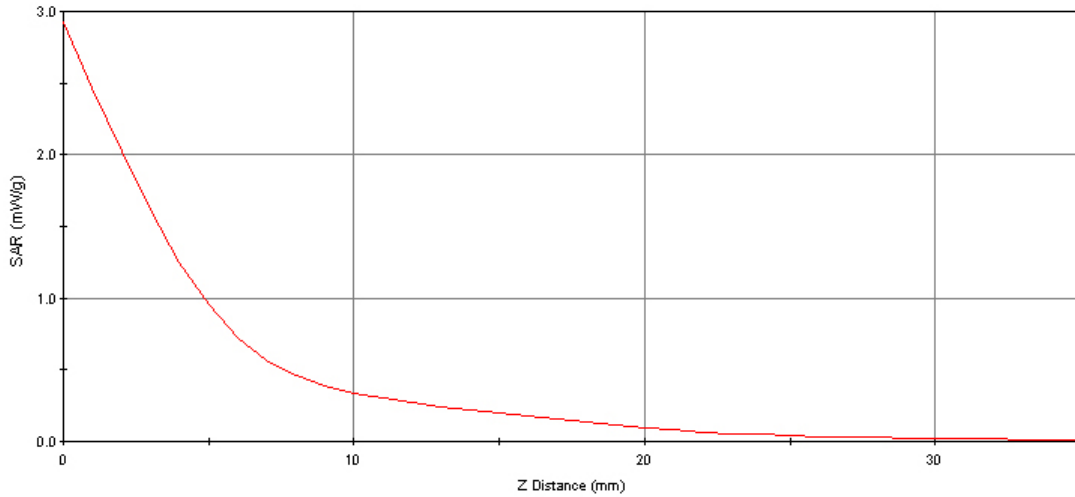

Graph 2a

Direct contact SAR (10g)
 DUI Left Side
 Distance 0 mm
 Mid Channel
 Frequency: 2437 MHz
 Mode: 802.11g



Date	Dielectric Constant ϵ_r	Conductivity σ [S/m]	Probe Con/F	Tissue Temp (°C)	10g SAR (W/kg)	Power Drift
17/12/03	50.6	2.03	6.6	22.0	0.35	0



Graph 2b

Body SAR (1g)
 DUI Left Side
 Distance 0 mm
 Mid Channel
 Frequency: 2437 MHz
 Mode: 802.11g



Date	Dielectric Constant ϵ_r	Conductivity σ [S/m]	Probe Con/F	Tissue Temp (°C)	1g SAR (W/kg)	Power Drift
17/12/03	50.6	2.03	6.6	22.0	0.84	0



SAR Data Report

SAR Data Report BENZ-BONDI_left_2437_g

Start : 17-Dec-03 03:57:30 pm
End : 17-Dec-03 04:03:12 pm
Code Version : 4.12
Robot Version: 4.08

Product Data:

Type : BENZ-BONDI
Frequency : 2437 MHz
Antenna Type : Center Fed
Antenna Posn. : Internal

Measurement Data:

Phantom Name : Uni-Dell
Phantom Type : Uniphantom
Tissue Type : Muscle
Tissue Dielectric : 50.600
Tissue Conductivity : 2.030
Tissue Density : 1.000
Crest Factor : 1.000
Robot Name : CRS

Probe Data:

Probe Name : 163
Probe Type : E Fld Triangle
Frequency : 2450 MHz
Tissue Type : Muscle
Calibrated Dielectric : 50.600
Calibrated Conductivity : 2.030
Probe Offset : 2.500 mm
Conversion Factor : 6.600
Diode Compression Pt : 76.0 mV
Probe Sensitivity : 0.580 0.580 0.580 mV/(mW/cm²)
Amplifier Gains : 20.00 20.00 20.00
Chan. Offset (mV) : -4.91 3.16 -0.53

Sample:

Rate: 6000 Samples/Sec
Count: 1000 Samples
NIDAQ Gain: 5
Scan Time: 166.7 msec

Comments:

Area Scan - Max Local SAR Value at x=16.0 y=-30.0 = 0.74 W/kg

Zoom Scan - Max Local SAR Value at x=15.0 y=-31.0 z=0.0 = 2.17 W/kg

Max 1g SAR at x=16.0 y=-29.0 z=0.0 = 0.84 W/kg

Max 10g SAR at x=15.0 y=-27.0 z=0.0 = 0.35 W/kg



Z Axis Scan

SAR - Z Axis
at Hotspot x:15.0 y:-31.0

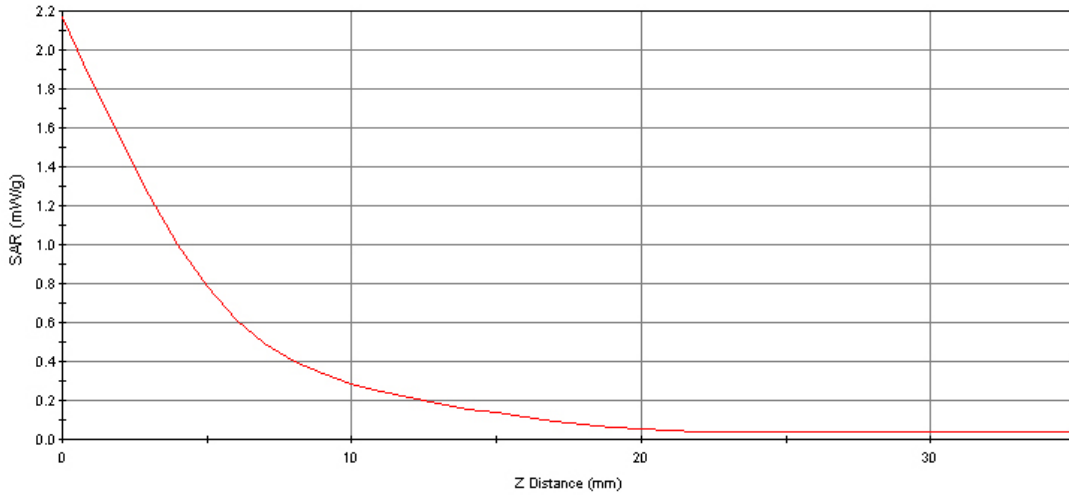

Graph 3

Body SAR (1g)
 DUI Top Side
 Distance 0 mm
 Mid Channel
 Frequency: 2437 MHz
 Mode: 802.11b

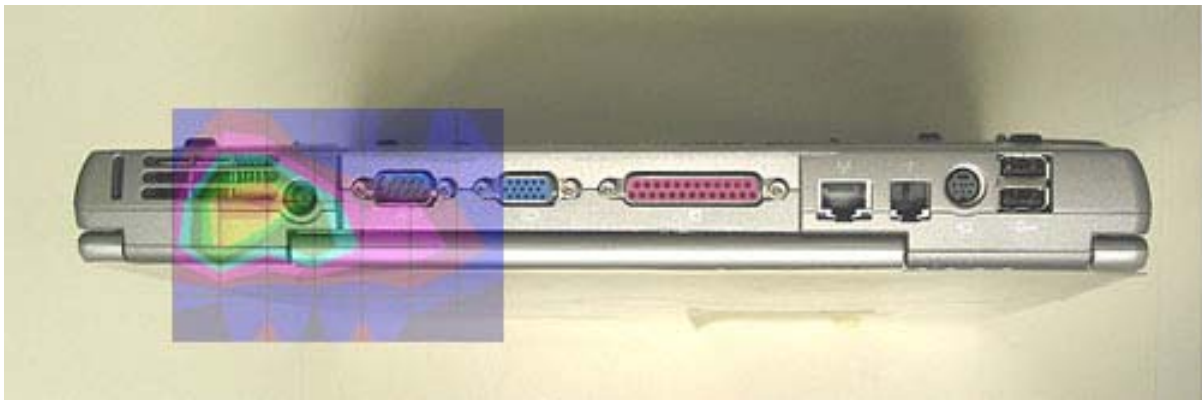

Date	Dielectric Constant ϵ_r	Conductivity σ [S/m]	Probe Con/F	Tissue Temp (°C)	1g SAR (W/kg)	Power Drift
17/12/03	50.6	2.03	6.6	22.0	0.56	0



SAR Data Report

SAR Data Report BENZ-BONDI_top_2437_b

Start : 17-Dec-03 05:48:23 pm
End : 17-Dec-03 05:54:07 pm
Code Version : 4.12
Robot Version: 4.08

Product Data:

Type : BENZ-BONDI
Frequency : 2437 MHz
Antenna Type : Center Fed
Antenna Posn. : Internal

Measurement Data:

Phantom Name : Uni-Dell
Phantom Type : Uniphantom
Tissue Type : Muscle
Tissue Dielectric : 50.600
Tissue Conductivity : 2.030
Tissue Density : 1.000
Crest Factor : 1.000
Robot Name : CRS

Probe Data:

Probe Name : 163
Probe Type : E Fld Triangle
Frequency : 2450 MHz
Tissue Type : Muscle
Calibrated Dielectric : 50.600
Calibrated Conductivity : 2.030
Probe Offset : 2.500 mm
Conversion Factor : 6.600
Diode Compression Pt : 76.0 mV
Probe Sensitivity : 0.580 0.580 0.580 mV/(mW/cm²)
Amplifier Gains : 20.00 20.00 20.00
Chan. Offset (mV) : -4.91 3.16 -0.53

Sample:

Rate: 6000 Samples/Sec
Count: 1000 Samples
NIDAQ Gain: 5
Scan Time: 166.7 msec

Comments:

Area Scan - Max Local SAR Value at x=-5.0 y=-36.0 = 0.35 W/kg

Zoom Scan - Max Local SAR Value at x=11.0 y=-35.0 z=0.0 = 6.05 W/kg

Max 1g SAR at x=6.0 y=-35.0 z=0.0 = 0.56 W/kg

Max 10g SAR at x=0.0 y=-35.0 z=0.0 = 0.23 W/kg



Z Axis Scan

SAR - Z Axis
at Hotspot x:11.0 y:-35.0

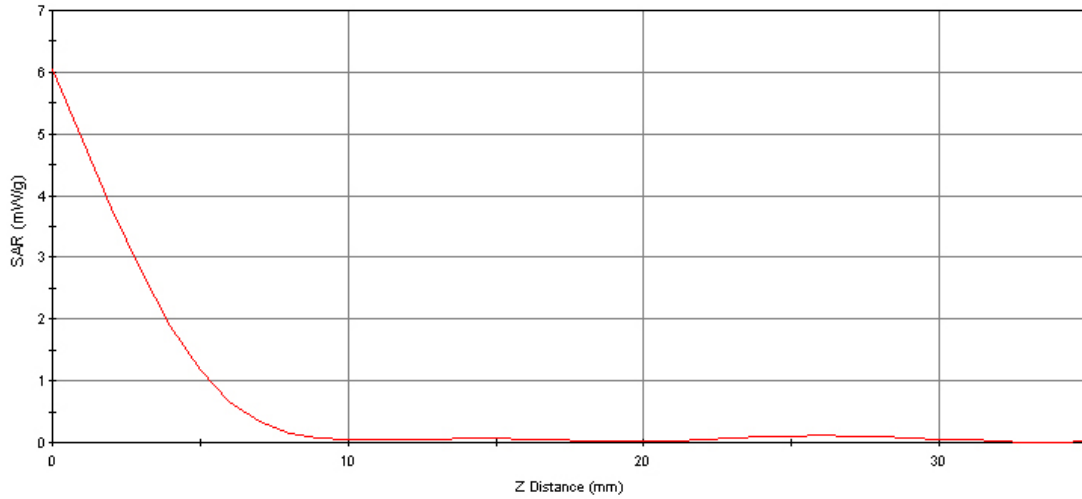

Graph 4

Body SAR (1g)
 DUI Top Side
 Distance 0 mm
 Mid Channel
 Frequency: 2437 MHz
 Mode: 802.11g

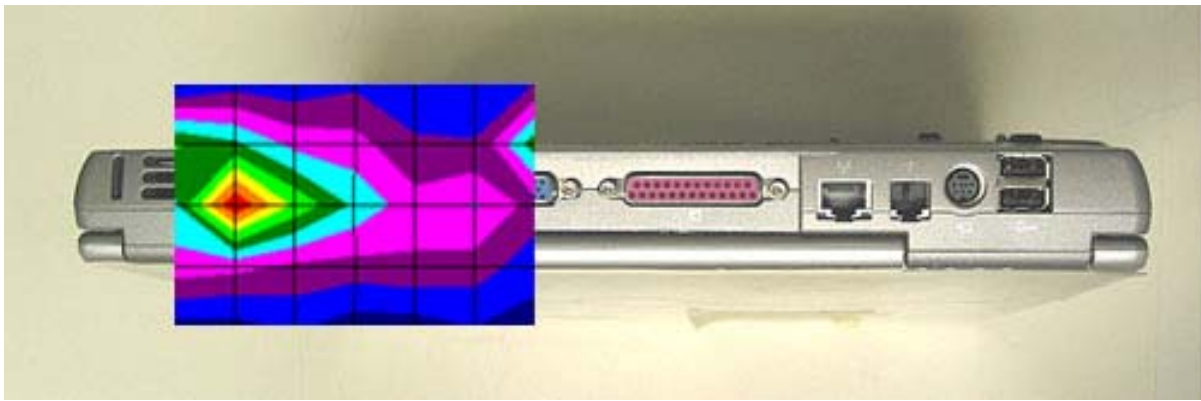

Date	Dielectric Constant ϵ_r	Conductivity σ [S/m]	Probe Con/F	Tissue Temp (°C)	1g SAR (W/kg)	Power Drift
17/12/03	50.6	2.03	6.6	22.0	0.38	0



SAR Data Report

SAR Data Report BENZ-BONDI_top_2437_g

Start : 17-Dec-03 02:55:33 pm
End : 17-Dec-03 03:01:42 pm
Code Version : 4.12
Robot Version: 4.08

Product Data:

Type : Dell Inspiron 600m
Frequency : 2437 MHz
Antenna Type : Center Fed
Antenna Posn. : Internal

Measurement Data:

Phantom Name : Uni-Dell
Phantom Type : Uniphantom
Tissue Type : Muscle
Tissue Dielectric : 50.600
Tissue Conductivity : 2.030
Tissue Density : 1.000
Crest Factor : 1.000
Robot Name : CRS

Probe Data:

Probe Name : 163
Probe Type : E Fld Triangle
Frequency : 2450 MHz
Tissue Type : Muscle
Calibrated Dielectric : 50.600
Calibrated Conductivity : 2.030
Probe Offset : 2.500 mm
Conversion Factor : 6.600
Diode Compression Pt : 76.0 mV
Probe Sensitivity : 0.580 0.580 0.580 mV/(mW/cm²)
Amplifier Gains : 20.00 20.00 20.00
Chan. Offset (mV) : -5.03 3.47 -1.17

Sample:

Rate: 6000 Samples/Sec
Count: 1000 Samples
NIDAQ Gain: 5
Scan Time: 166.7 msec

Comments:

Area Scan - Max Local SAR Value at x=19.0 y=-40.0 = 0.28 W/kg

Zoom Scan - Max Local SAR Value at x=19.0 y=-45.0 z=0.0 = 0.74 W/kg

Max 1g SAR at x=20.0 y=-38.0 z=0.0 = 0.38 W/kg

Max 10g SAR at x=20.0 y=-37.0 z=0.0 = 0.14 W/kg



Z Axis Scan

SAR - Z Axis
at Hotspot x:19.0 y:-45.0

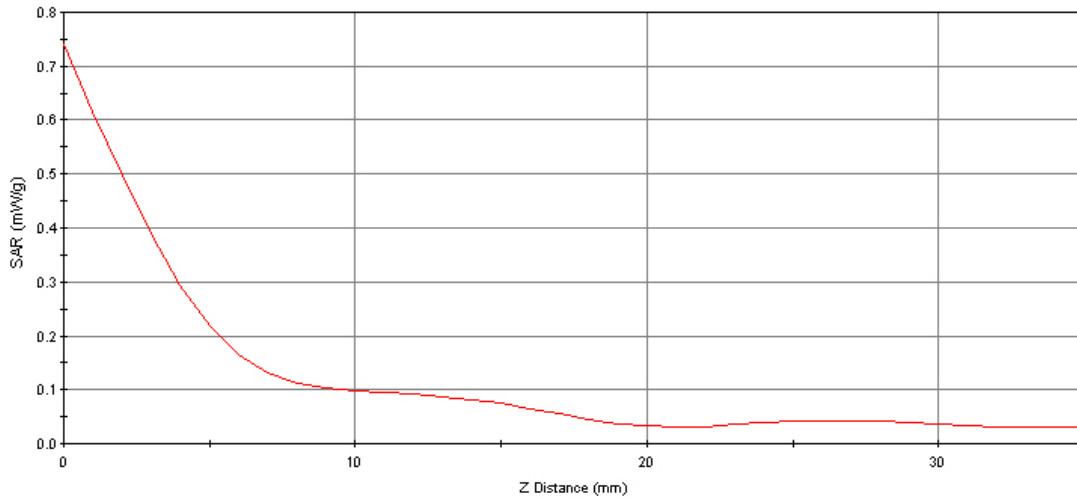

Graph 5

Body SAR (1g)
 DUI Front Side
 Distance 0 mm
 Mid Channel
 Frequency: 2437 MHz
 Mode: 802.11b

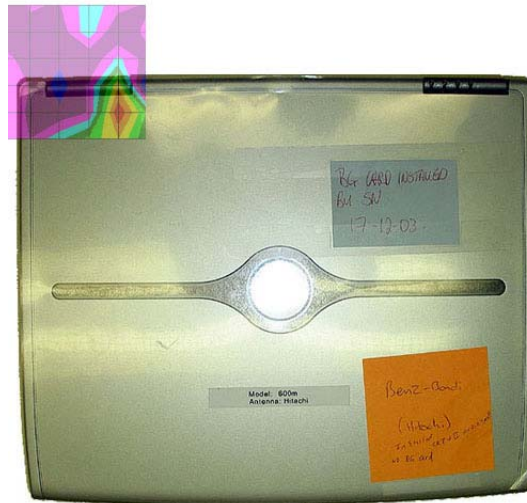

Date	Dielectric Constant ϵ_r	Conductivity σ [S/m]	Probe Con/F	Tissue Temp ($^{\circ}$ C)	1g SAR (W/kg)	Power Drift
17/12/03	50.6	2.03	6.6	22.0	0.27	0



SAR Data Report

SAR Data Report BENZ-BONDI_front_2437_b

Start : 17-Dec-03 06:30:49 pm
End : 17-Dec-03 06:36:35 pm
Code Version : 4.12
Robot Version: 4.08

Product Data:

Type : BENZ-BONDI
Frequency : 2437 MHz
Antenna Type : Center Fed
Antenna Posn. : Internal

Measurement Data:

Phantom Name : APREL-Uni
Phantom Type : Uniphantom
Tissue Type : Muscle
Tissue Dielectric : 50.600
Tissue Conductivity : 2.030
Tissue Density : 1.000
Crest Factor : 1.000
Robot Name : CRS

Probe Data:

Probe Name : 163
Probe Type : E Fld Triangle
Frequency : 2450 MHz
Tissue Type : Muscle
Calibrated Dielectric : 50.600
Calibrated Conductivity : 2.030
Probe Offset : 2.500 mm
Conversion Factor : 7.500
Diode Compression Pt : 76.0 mV
Probe Sensitivity : 0.580 0.580 0.580 mV/(mW/cm²)
Amplifier Gains : 20.00 20.00 20.00
Chan. Offset (mV) : -4.91 3.16 -0.53

Sample:

Rate: 6000 Samples/Sec
Count: 1000 Samples
NIDAQ Gain: 5
Scan Time: 166.7 msec

Comments:

Area Scan - Max Local SAR Value at x=36.0 y=38.0 = 0.22 W/kg

Zoom Scan - Max Local SAR Value at x=52.0 y=46.0 z=0.0 = 2.31 W/kg

Max 1g SAR at x=47.0 y=47.0 z=0.0 = 0.27 W/kg

Max 10g SAR at x=31.0 y=39.0 z=0.0 = 0.09 W/kg



Z Axis Scan

SAR - Z Axis
at Hotspot x:52.0 y:46.0

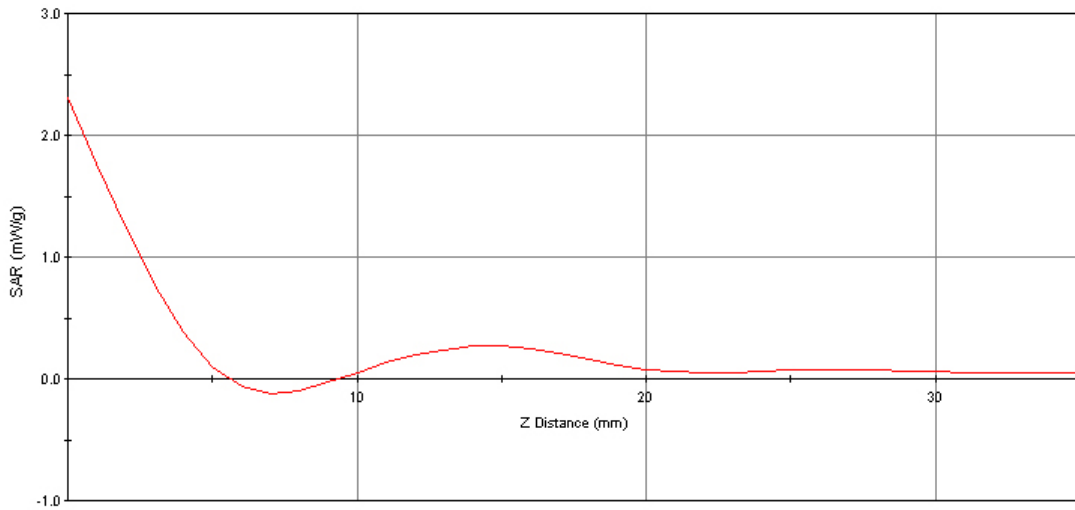

Graph 6

Body SAR (1g)
 DUI Front Side
 Distance 0 mm
 Mid Channel
 Frequency: 2437 MHz
 Mode: 802.11g

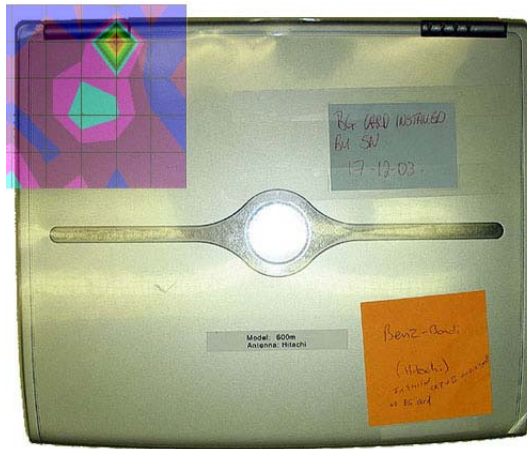

Date	Dielectric Constant ϵ_r	Conductivity σ [S/m]	Probe Con/F	Tissue Temp ($^{\circ}$ C)	1g SAR (W/kg)	Power Drift
17/12/03	50.6	2.03	6.6	22.0	0.16	0



SAR Data Report

SAR Data Report BENZ-BONDI_front_2437_g

Start : 17-Dec-03 06:51:11 pm
End : 17-Dec-03 07:01:59 pm
Code Version : 4.12
Robot Version: 4.08

Product Data:

Type : BENZ-BONDI
Frequency : 2437 MHz
Antenna Type : Center Fed
Antenna Posn. : Internal

Measurement Data:

Phantom Name : APREL-Uni
Phantom Type : Uniphantom
Tissue Type : Muscle
Tissue Dielectric : 50.600
Tissue Conductivity : 2.030
Tissue Density : 1.000
Crest Factor : 1.000
Robot Name : CRS

Probe Data:

Probe Name : 163
Probe Type : E Fld Triangle
Frequency : 2450 MHz
Tissue Type : Muscle
Calibrated Dielectric : 50.600
Calibrated Conductivity : 2.030
Probe Offset : 2.500 mm
Conversion Factor : 10.000
Diode Compression Pt : 76.0 mV
Probe Sensitivity : 0.580 0.580 0.580 mV/(mW/cm²)
Amplifier Gains : 20.00 20.00 20.00
Chan. Offset (mV) : -4.91 3.16 -0.53

Sample:

Rate: 6000 Samples/Sec
Count: 1000 Samples
NIDAQ Gain: 5
Scan Time: 166.7 msec

Comments:

Area Scan - Max Local SAR Value at x=20.0 y=68.0 = 0.15 W/kg

Zoom Scan - Max Local SAR Value at x=23.0 y=68.0 z=0.0 = 0.33 W/kg

Max 1g SAR at x=12.0 y=66.0 z=15.0 = 0.16 W/kg

Max 10g SAR at x=15.0 y=65.0 z=5.0 = 0.07 W/kg



Z Axis Scan

SAR - Z Axis
at Hotspot x:23.0 y:68.0

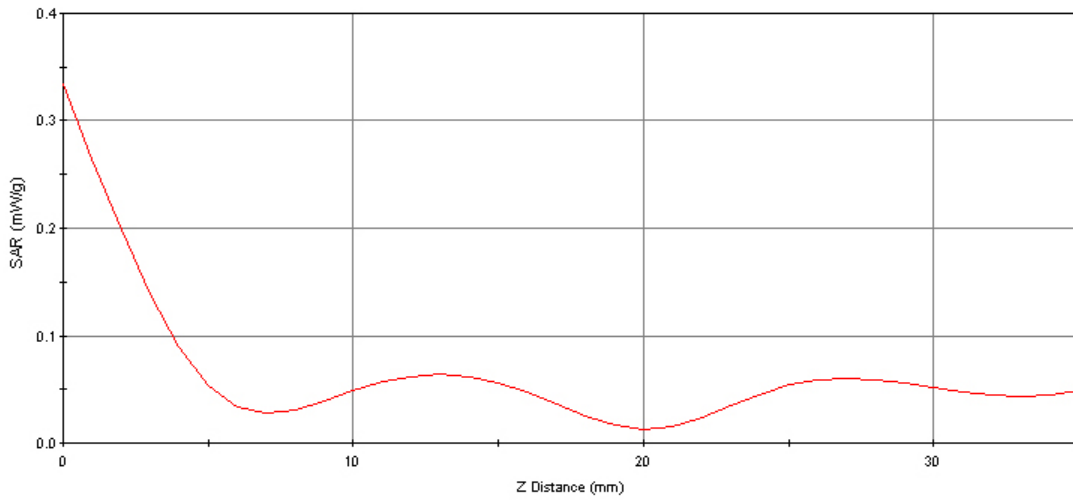

Graph 7

Body SAR (1g)
 DUI Back Side
 Distance 0 mm
 Mid Channel
 Frequency: 2437 MHz
 Mode: 802.11b



Date	Dielectric Constant ϵ_r	Conductivity σ [S/m]	Probe Con/F	Tissue Temp (°C)	1g SAR (W/kg)	Power Drift
17/12/03	50.6	2.03	6.6	22.0	0.15	0



SAR Data Report

SAR Data Report BENZ-BONDI_back_2437_b

Start : 17-Dec-03 02:59:08 am
End : 17-Dec-03 03:05:08 am
Code Version : 4.12
Robot Version: 4.08

Product Data:

Type : Benz
Frequency : 2437 MHz
Transmit Pwr : 0.045 W
Antenna Type : Center Fed
Antenna Posn. : Internal

Measurement Data:

Phantom Name : APREL-Uni
Phantom Type : Uniphantom
Tissue Type : Muscle
Tissue Dielectric : 50.600
Tissue Conductivity : 2.030
Tissue Density : 1.000
Crest Factor : 1.000
Robot Name : CRS

Probe Data:

Probe Name : 163
Probe Type : E Fld Triangle
Frequency : 2450 MHz
Tissue Type : Muscle
Calibrated Dielectric : 50.600
Calibrated Conductivity : 2.010
Probe Offset : 2.500 mm
Conversion Factor : 6.600
Diode Compression Pt : 76.0 mV
Probe Sensitivity : 0.580 0.580 0.580 mV/(mW/cm²)
Amplifier Gains : 20.00 20.00 20.00
Chan. Offset (mV) : -5.48 3.16 -1.45

Sample:

Rate: 6000 Samples/Sec
Count: 1000 Samples
NIDAQ Gain: 5
Scan Time: 166.7 msec

Comments:

Area Scan - Max Local SAR Value at x=30.0 y=61.0 = 0.10 W/kg

Zoom Scan - Max Local SAR Value at x=35.0 y=52.0 z=0.0 = 0.36 W/kg

Max 1g SAR at x=36.0 y=52.0 z=0.0 = 0.15 W/kg

Max 10g SAR at x=32.0 y=56.0 z=0.0 = 0.07 W/kg



Z Axis Scan

SAR - Z Axis
at Hotspot x:35.0 y:52.0

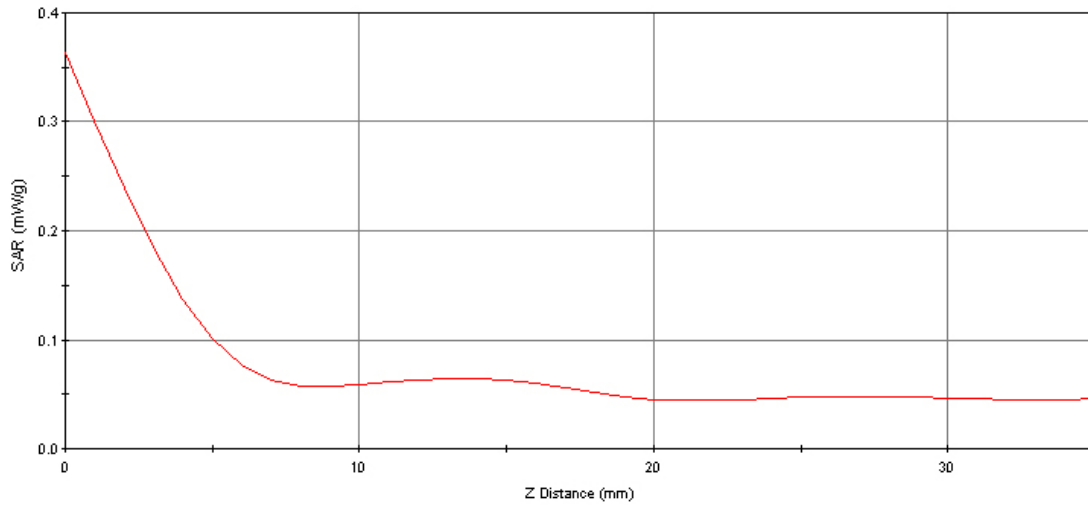

Graph 8

Body SAR (1g)
 DUI Back Side
 Distance 0 mm
 Mid Channel
 Frequency: 2437 MHz
 Mode: 802.11g

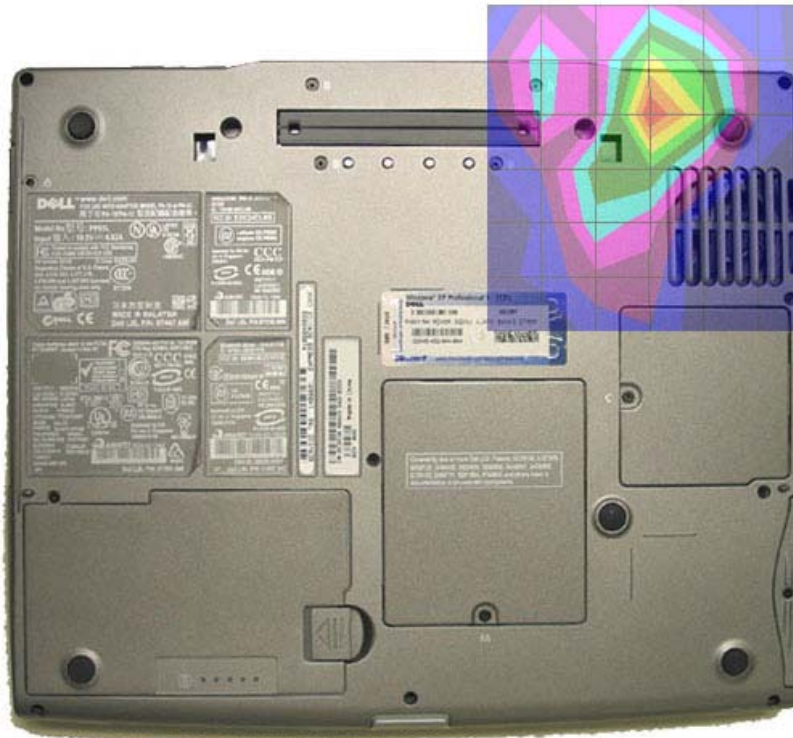

Date	Dielectric Constant ϵ_r	Conductivity σ [S/m]	Probe Con/F	Tissue Temp (°C)	1g SAR (W/kg)	Power Drift
17/12/03	50.6	2.03	6.6	22.0	0.13	0



SAR Data Report

SAR Data Report BENZ-BONDI_back_2437_g

Start : 17-Dec-03 12:42:31 am
End : 17-Dec-03 12:48:15 am
Code Version : 4.12
Robot Version: 4.08

Product Data:

Type : Benz
Frequency : 2412 MHz
Antenna Type : End Fed
Antenna Posn. : Internal

Measurement Data:

Phantom Name : Laptop_edge
Phantom Type : Uniphantom
Tissue Type : Muscle
Tissue Dielectric : 50.400
Tissue Conductivity : 2.030
Tissue Density : 1.000
Crest Factor : 1.000
Robot Name : CRS

Probe Data:

Probe Name : 163
Probe Type : E Fld Triangle
Frequency : 2450 MHz
Tissue Type : Muscle
Calibrated Dielectric : 50.400
Calibrated Conductivity : 2.030
Probe Offset : 2.500 mm
Conversion Factor : 6.600
Diode Compression Pt : 76.0 mV
Probe Sensitivity : 0.580 0.580 0.580 mV/(mW/cm²)
Amplifier Gains : 20.00 20.00 20.00
Chan. Offset (mV) : -5.03 3.39 -0.64

Sample:

Rate: 6000 Samples/Sec
Count: 1000 Samples
NIDAQ Gain: 5
Scan Time: 166.7 msec

Comments:

Keyboard side, Open, 0mm

Area Scan - Max Local SAR Value at x=-11.0 y=7.0 = 0.09 W/kg

Zoom Scan - Max Local SAR Value at x=-10.0 y=1.0 z=0.0 = 0.26 W/kg

Max 1g SAR at x=-9.0 y=4.0 z=0.0 = 0.13 W/kg

Max 10g SAR at x=-11.0 y=7.0 z=0.0 = 0.06 W/kg



Z Axis Scan

SAR - Z Axis
at Hotspot x:-10.0 y:1.0

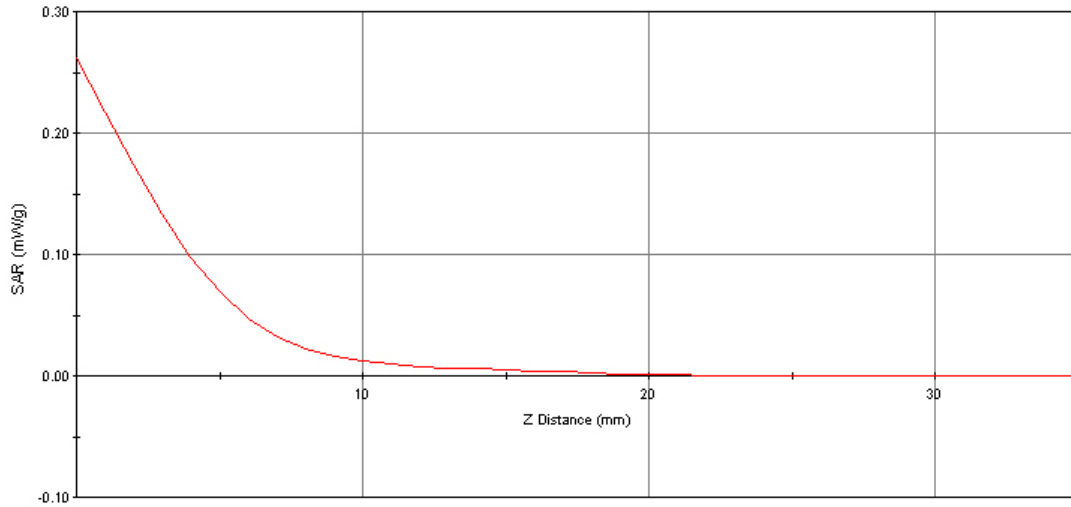

Appendix B

Setup Pictures



Picture 1

DUI Left Side



Picture 2

DUT Left Side

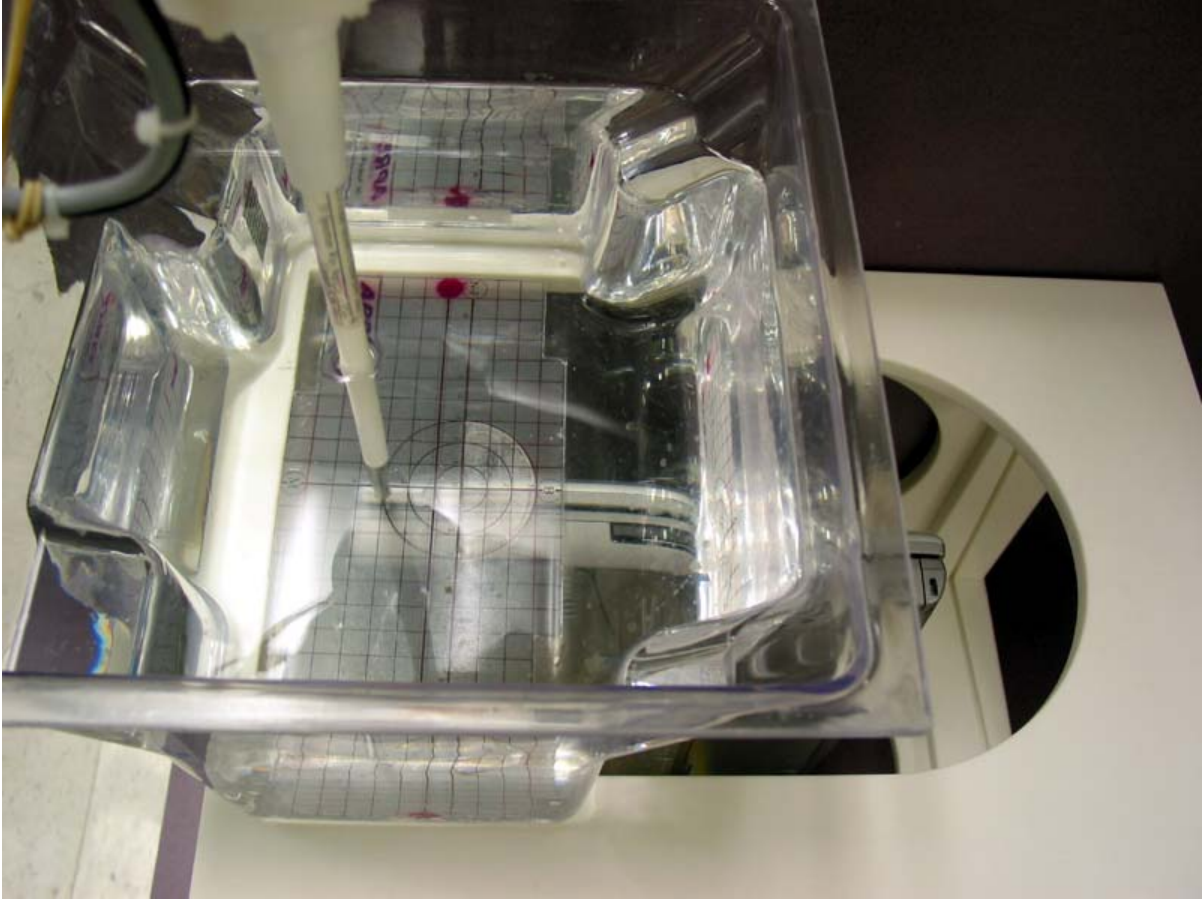

Picture 3

DUT Front Side



Picture 4

DUT Front Side

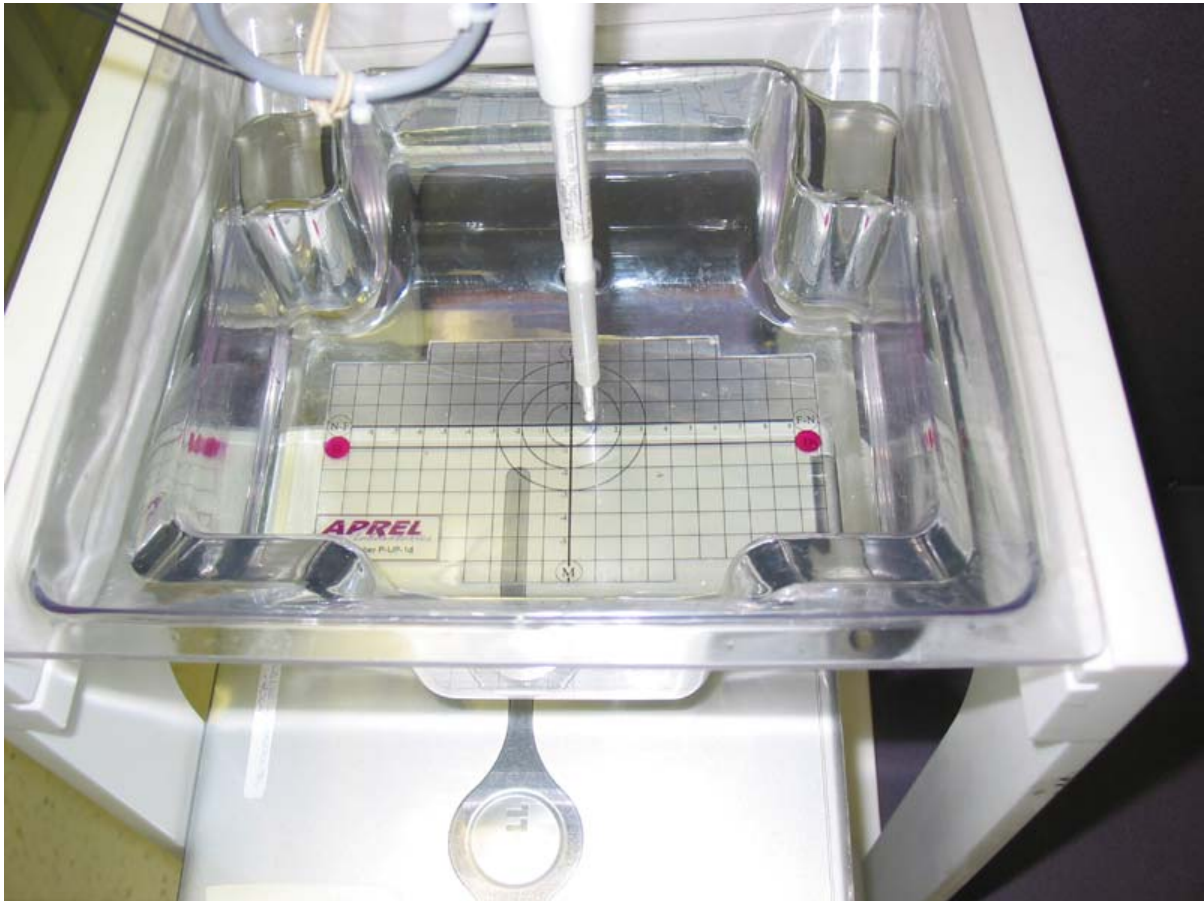

Picture 5

DUT Front Side



Picture 6

DUT Back Side

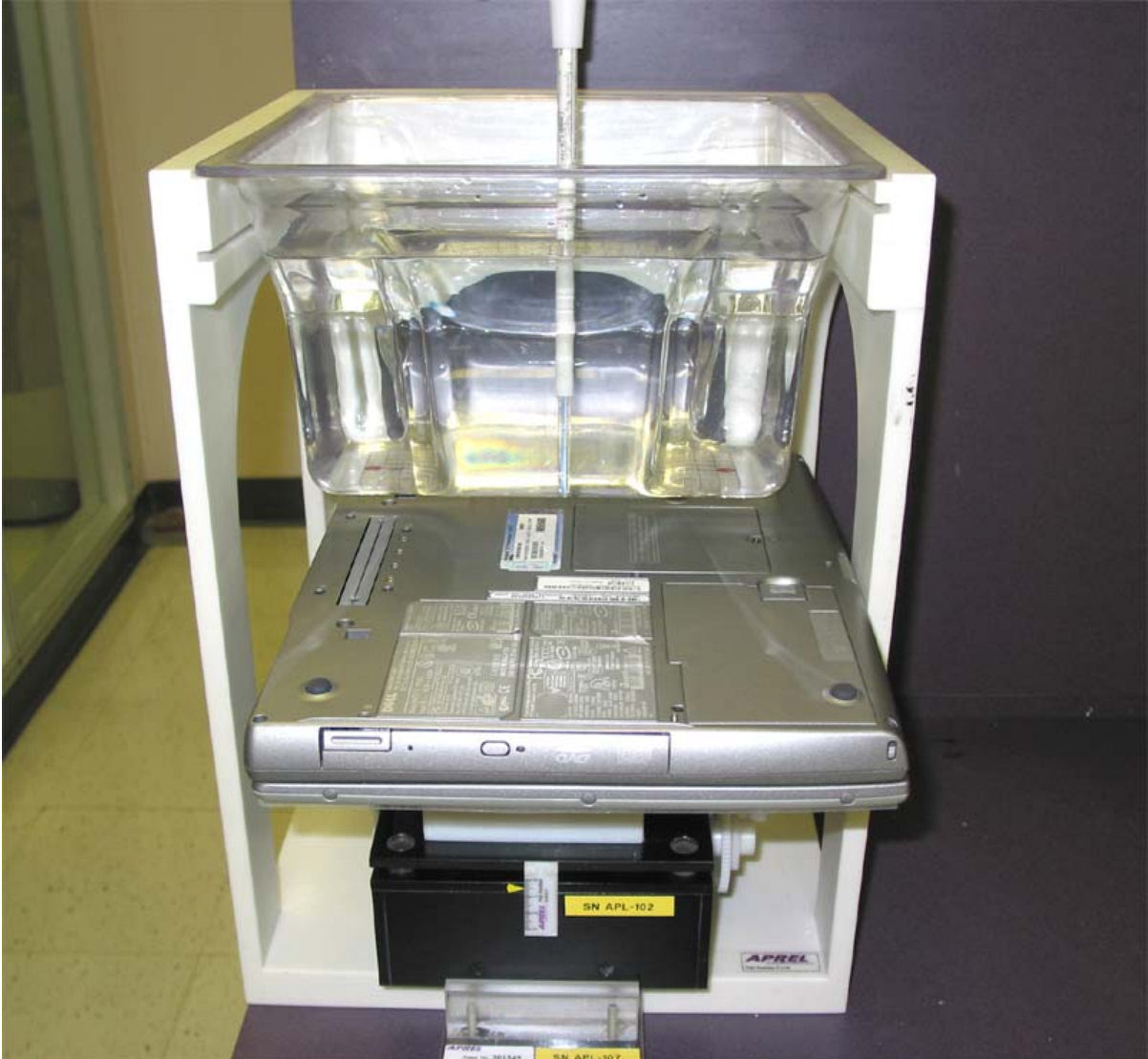

Picture 7

DUT Back Side

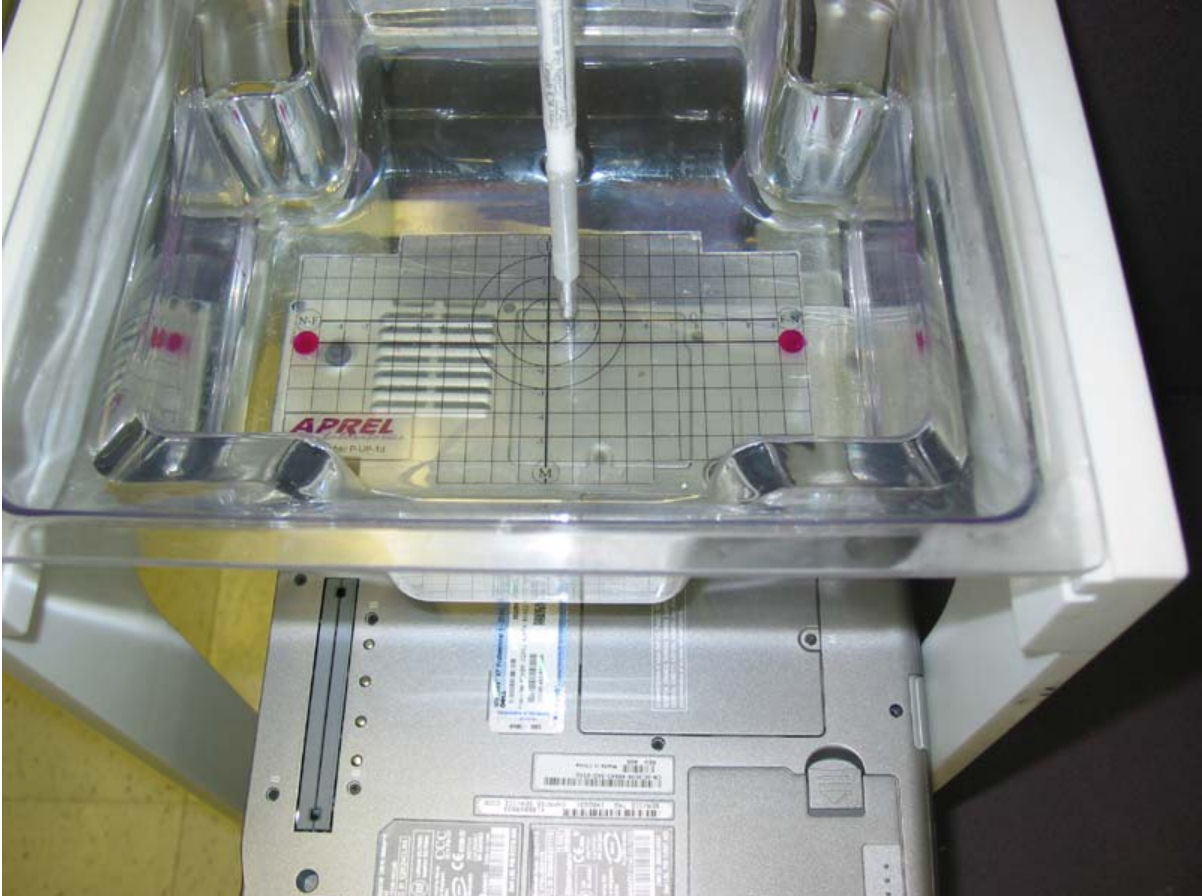

Picture 8

DUT Back Side



Appendix C

Validation Scan Results



VALIDATION SCAN

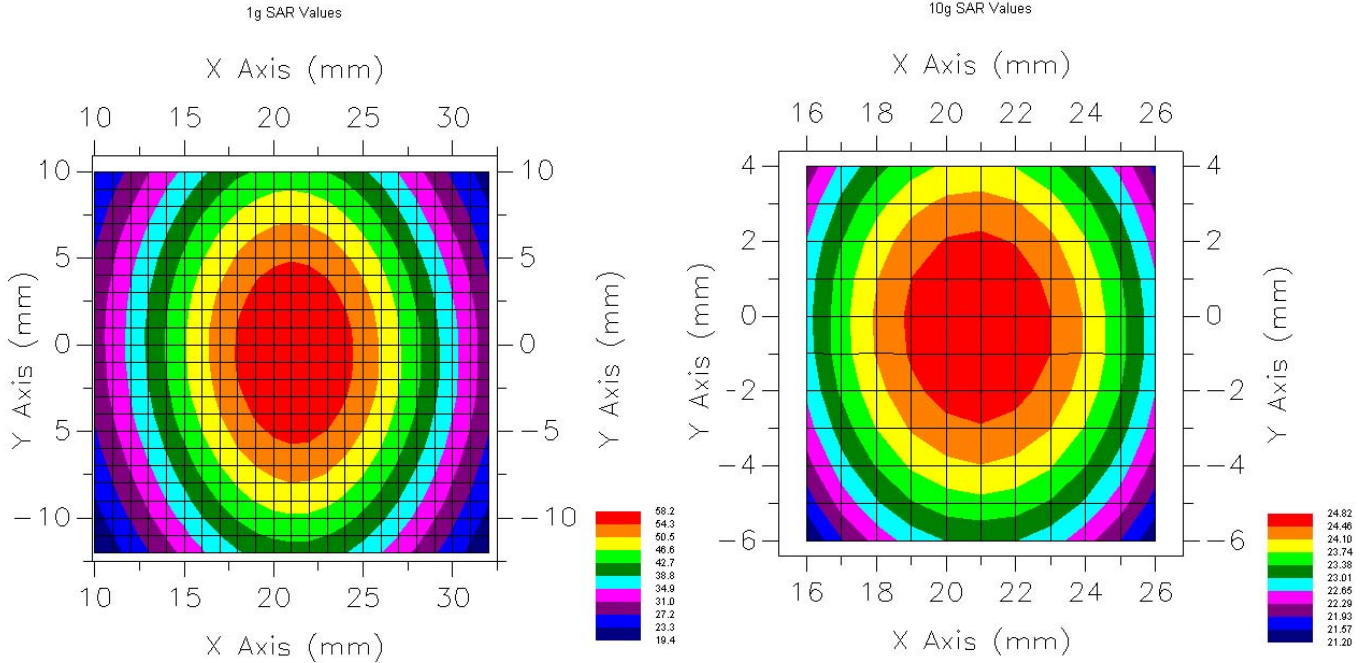

Date: 17th December 2003
 Frequency: 2450 MHz
 Tissue Type: Muscle
 Epsilon: 50.6
 Sigma: 2.03
 Tissue Calibration Date: 17th December 2003
 Conversion Factor: 6.6
 Input Power to Dipole: 1 W
 Duty Cycle: 1
 Distance from Dipole to Tissue: 10 mm
 Tissue Temperature: 22°C
 Tissue Depth: 15 cm

Measured 1 Gram SAR (W/Kg)	Target 1 Gram SAR (W/Kg)	Delta (%)
54.1	52.4	+3.2

Measured 10 Gram SAR (W/Kg)	Target 10 Gram SAR (W/Kg)	Delta (%)
24.4	24.0	+ 1.7



Appendix d: Uncertainty Budget

Intel PRO/Wireless 802.11b/g Mini-PCI type 3A WLAN Adapter.

Source of Uncertainty	Description (Annex)	Tolerance Value	Probability Distribution	Divisor	c_i^1 (1-g)	c_i^1 (10-g)	Standard Uncertainty (1-g)	Standard Uncertainty (10-g)	v_i^2 or v_{eff}
Measurement System									
Probe Calibration	E1.1	3.5	normal	1	1	1	3.5	3.5	∞
Axial Isotropy	E1.2	3.7	rectangular	$\sqrt{3}$	$(1-cp)^{1/2}$	$(1-cp)1/2$	1.5	1.5	∞
Hemispherical Isotropy	E1.2	10.9	rectangular	$\sqrt{3}$	\sqrt{cp}	\sqrt{cp}	4.4	4.4	∞
Boundary Effect	E1.3	1.0	rectangular	$\sqrt{3}$	1	1	0.6	0.6	∞
Linearity	E1.4	4.7	rectangular	$\sqrt{3}$	1	1	2.7	2.7	∞
Detection Limit	E1.5	1.0	rectangular	$\sqrt{3}$	1	1	0.6	0.6	∞
Readout Electronics	E1.6	1.0	normal	1	1	1	1.0	1.0	∞
Response Time	E1.7	0.8	rectangular	$\sqrt{3}$	1	1	0.5	0.5	∞
Integration Time	E1.8	1.7	rectangular	$\sqrt{3}$	1	1	1.0	1.0	∞
RF Ambient Condition	E5.1	3.0	rectangular	$\sqrt{3}$	1	1	1.7	1.7	∞
Probe Positioner Mech. Restrictions	E5.2	0.4	rectangular	$\sqrt{3}$	1	1	0.2	0.2	∞
Probe Positioning with respect to Phantom Shell	E5.3	2.9	rectangular	$\sqrt{3}$	1	1	1.7	1.7	∞
Extrapolation and Integration	E4.2	3.7	rectangular	$\sqrt{3}$	1	1	2.1	2.1	∞
Test Sample Positioning	E3.1.3	4.0	normal	1	1	1	4.0	4.0	11
Device Holder Uncertainty	E3.1.2	2.0	normal	1	1	1	2.0	2.0	8
Drift of Output Power	Section 6.6.2	0.0	rectangular	$\sqrt{3}$	1	1	0.0	0.0	∞
Phantom and Setup									
Phantom Uncertainty (shape and thickness tolerance)	E2.1	3.4	rectangular	$\sqrt{3}$	1	1	2.0	2.0	∞
Liquid Conductivity (target)	E2.2	4.0	rectangular	$\sqrt{3}$	0.7	0.5	1.3	0.9	∞
Liquid Conductivity (meas.)	E2.2	2.0	rectangular	$\sqrt{3}$	0.7	0.5	0.8	0.6	∞
Liquid Permittivity (target)	E2.2	4.1	rectangular	$\sqrt{3}$	0.6	0.5	1.4	1.2	∞
Liquid Permittivity (meas.)	E2.2	2.0	rectangular	$\sqrt{3}$	0.6	0.5	0.7	0.6	∞
Combined Uncertainty			RSS				9.0	8.9	∞
Combined Uncertainty (coverage factor = 2)			Normal (k=2)				18.0	17.8	∞



Appendix E

Probe Calibration Certificate



NCL CALIBRATION LABORATORIES

Calibration File No.: C-P-0265

C E R T I F I C A T E O F C A L I B R A T I O N

It is certified that the equipment identified below has been calibrated in the
NCL CALIBRATION LABORATORIES by qualified personnel following recognized
procedures and using transfer standards traceable to NRC/NIST.

Equipment: Miniature Isotropic RF Probe 2.45 GHz

Manufacturer: APREL Laboratories

Model No.: E-010

Serial No.: 163

Calibration Procedure: SSI/DRB-TP-D01-032

Project No: Probe Cal Internal

Calibrated: November 5th 2003

Recalibration required: November 4th 2004

Released on: November 5th 2003

Released By: _____

NCL CALIBRATION LABORATORIES

51 SPECTRUM WAY
NEPEAN, ONTARIO
CANADA K2R 1E6

Division of APREL Lab.
TEL: (613) 820-4988
FAX: (613) 820-4161



INTRODUCTION

This Calibration Report reproduces the results of the calibration performed in line with the SSI/DRB-TP-D01-032 E-Field Probe Calibration Procedure. The results contained within this report are for APREL E-Field Probe E-010 163.

REFERENCES

SSI/DRB-TP-D01-032 E-Field Probe Calibration Procedure
IEEE 1528 *DRAFT* "Recommended Practice for Determining the Peak Spatial-Average Specific Absorption Rate (SAR) in the Human Body Due to Wireless Communications Devices: Experimental Techniques"
SSI-TP-014 Tissue Calibration Procedure

Conditions

Probe 163 is a working released probe.

Ambient Temperature of the Laboratory: 22 °C +/- 0.5°C
Temperature of the Tissue: 21 °C +/- 0.5°C



CALIBRATION RESULTS SUMMARY

Probe Type: E-Field Probe E-010

Serial Number: 163

Frequency: 2450 MHz

Sensor Offset: 2.4 mm

Sensor Length: **2.5 mm**

Tip Enclosure: **Glass***

Tip Diameter: **7 mm**

Tip Length: **40 mm**

Total Length: **290 mm**

*Resistive to recommended tissue recipes per IEEE 1528

SENSITIVITY IN AIR

Channel X: 0.58 $\mu\text{V}/(\text{V}/\text{m})^2$

Channel Y: 0.58 $\mu\text{V}/(\text{V}/\text{m})^2$

Channel Z: 0.58 $\mu\text{V}/(\text{V}/\text{m})^2$

Diode Compression Point: 76 mV



SENSITIVITY IN BODY TISSUE

Frequency: 2450 MHz
Epsilon: 52.7(+/-5%) Sigma: 1.95 S/m (+/-10%)

ConvF

Channel X: 6.6

Channel Y: 6.6

Channel Z: 6.6

Tissue sensitivity values were calculated using a load impedance of 5 M Ω .

Boundary Effect:

Uncertainty resulting from the boundary effect is less than 2% for the distance between the tip of the probe and the tissue boundary, when less than 2.6mm.

Spatial Resolution:

The measured probe tip diameter is 7 mm (+/- 0.01 mm) and therefore meets the requirements of SSI/DRB-TP-D01-032 for spatial resolution.

RECEIVING PATTERN 2450 MHZ (AIR)

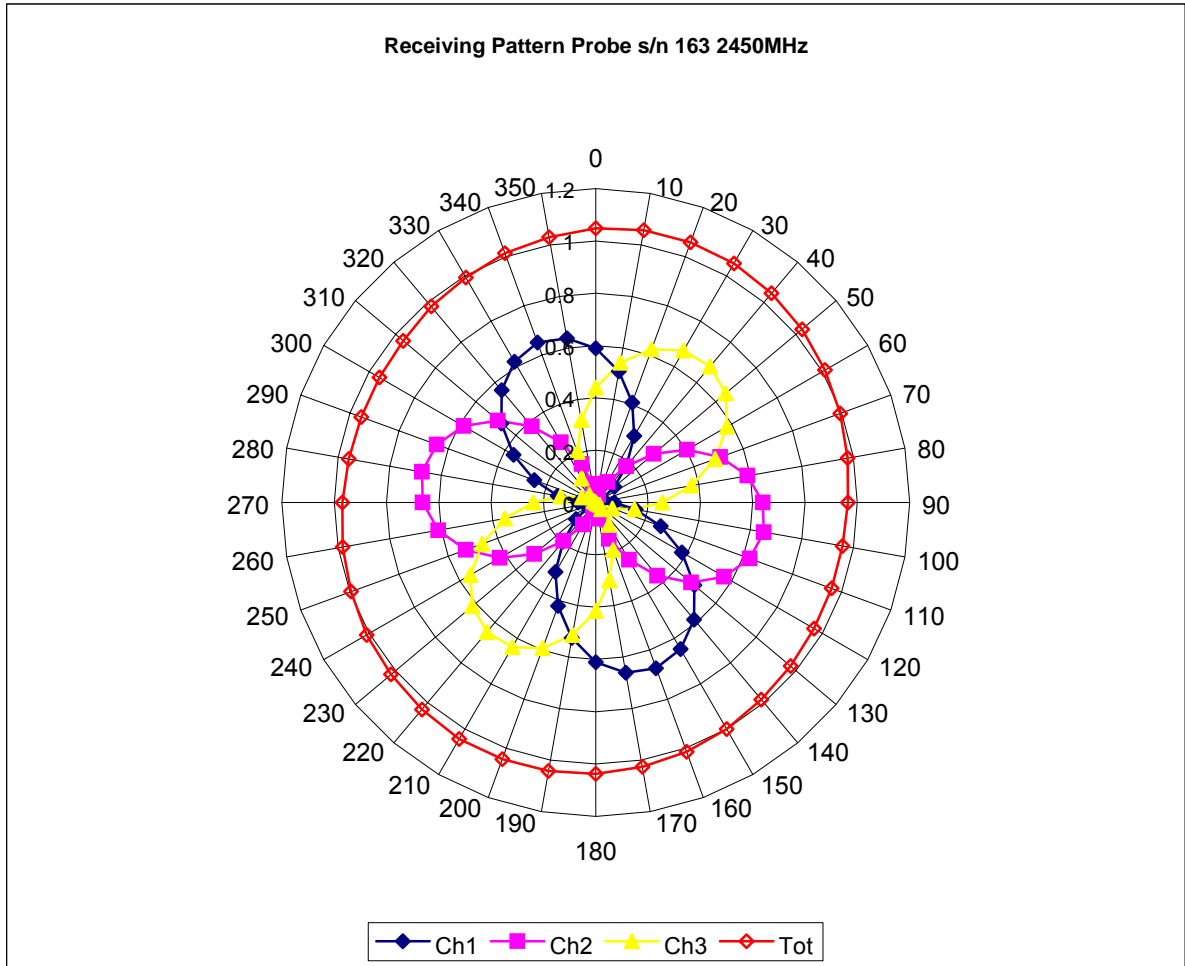

ISOTROPY ERROR 2450 MHZ (AIR)

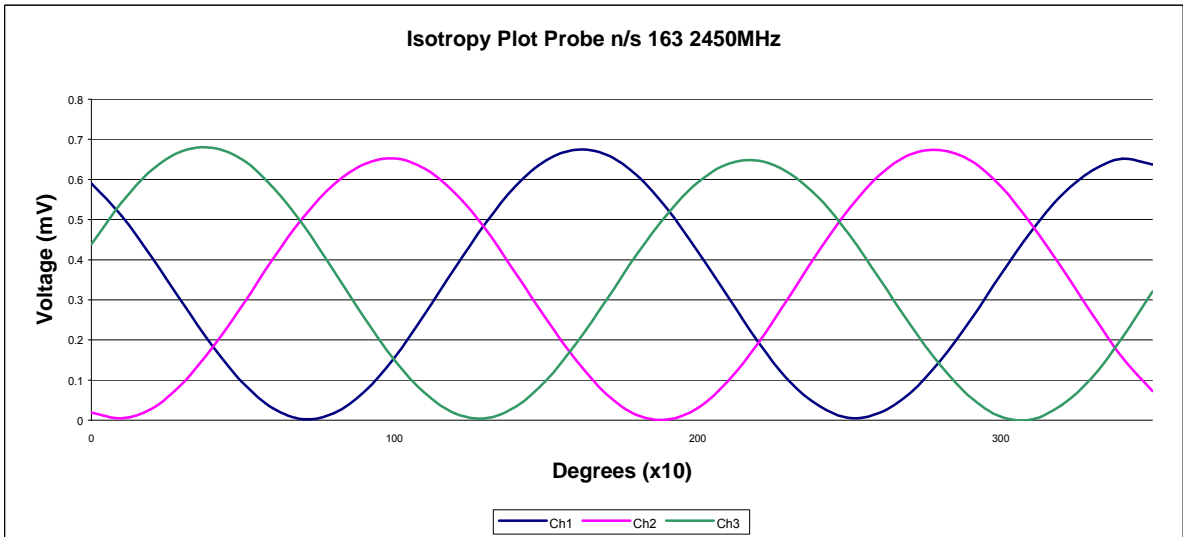
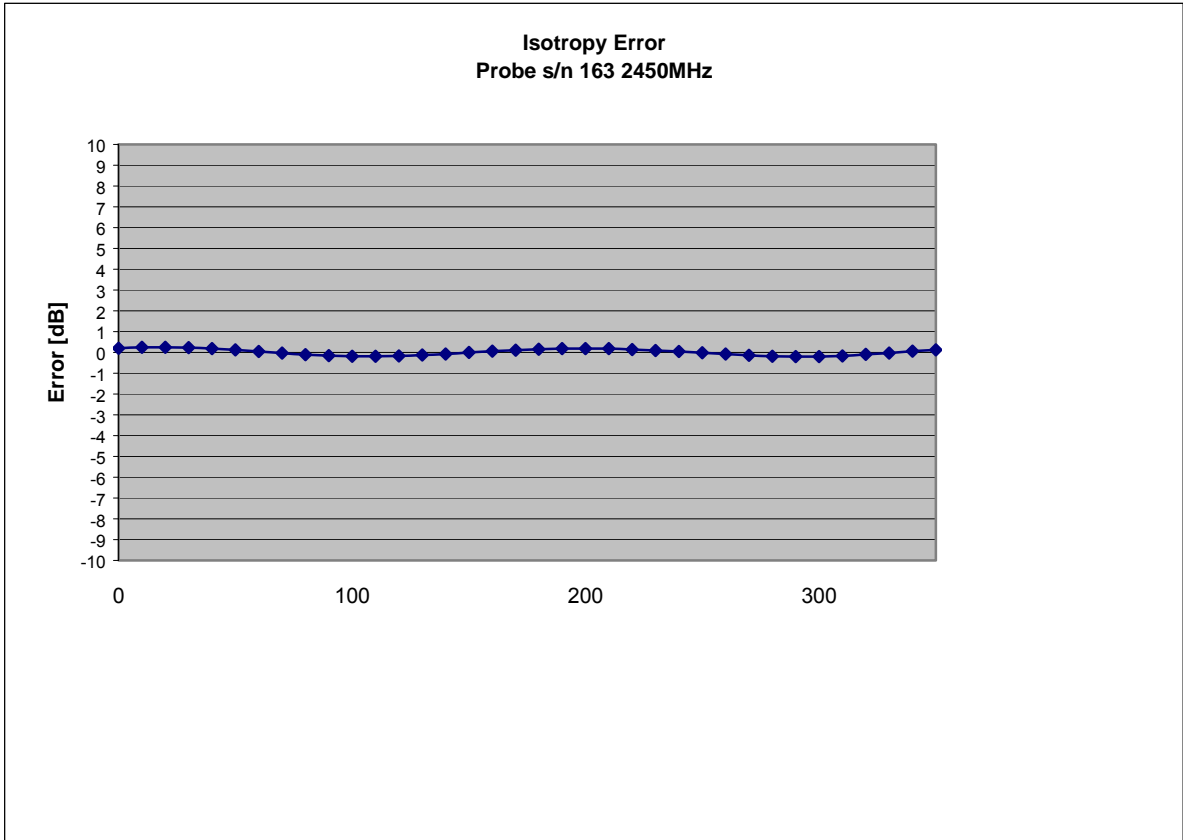

DYNAMIC RANGE

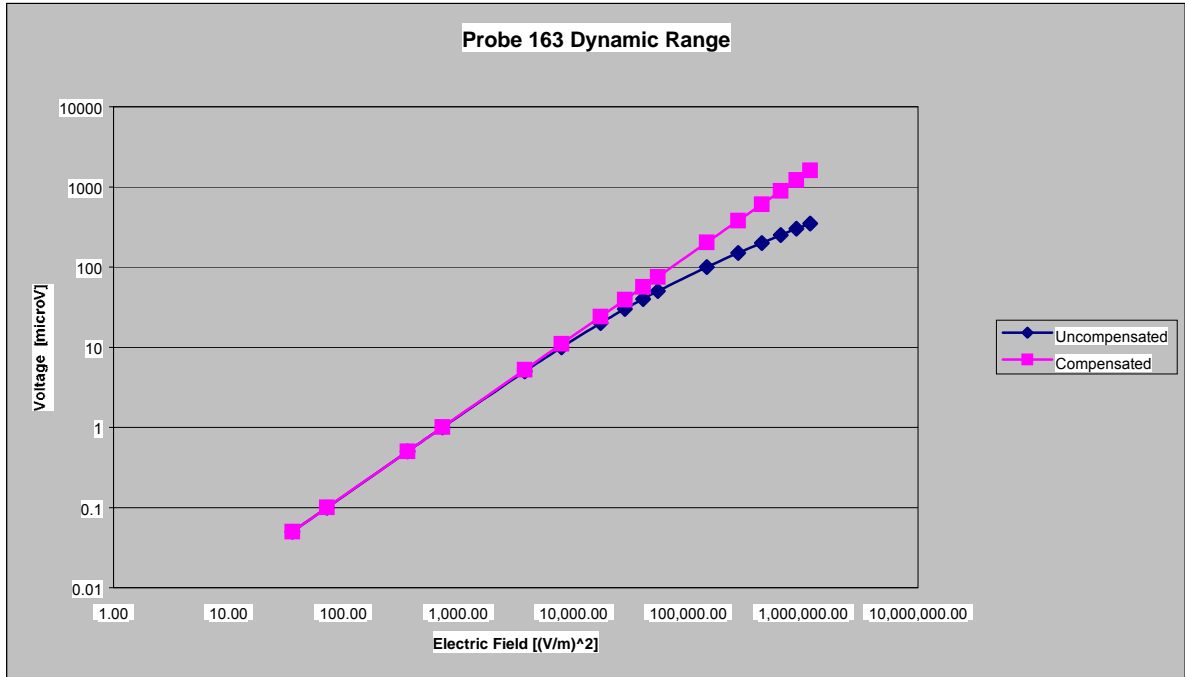

Video Bandwidth

Probe Frequency Characteristics

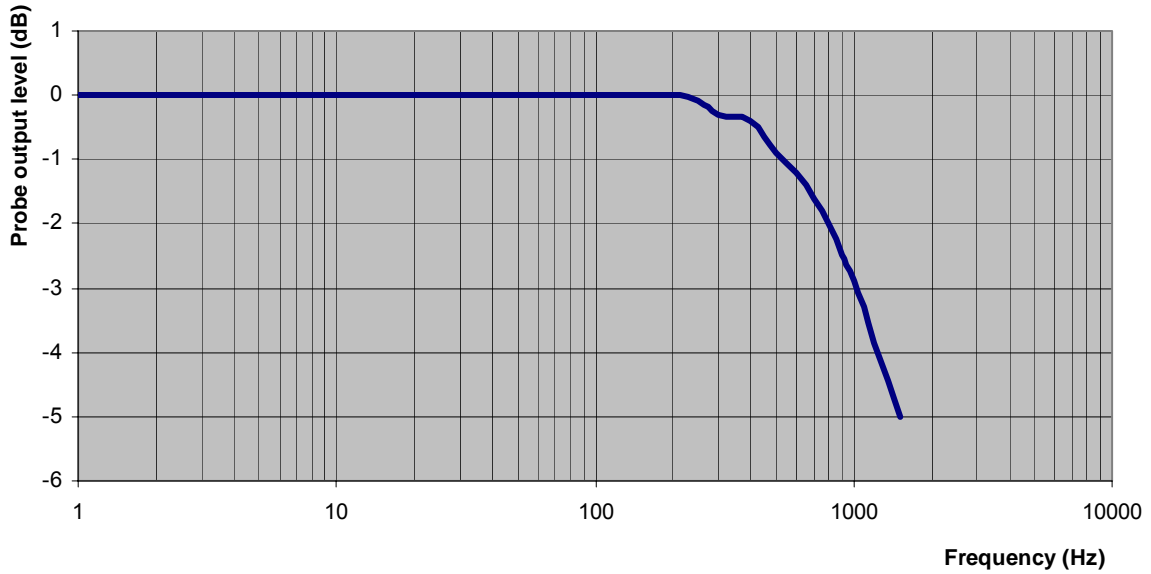

Video Bandwidth at 500 Hz 1 dB
Video Bandwidth at 1.02 KHz: 3 dB



CONVERSION FACTOR UNCERTAINTY ASSESSMENT

Frequency: 2450 MHz

Epsilon: 52.7 (+/-5%) **Sigma:** 1.95 S/m (+/-10%)

ConvF

Channel X: **6.6** **7%(K=2)**

Channel Y: **6.6** **7%(K=2)**

Channel Z: 6.6 **7%(K=2)**

To minimize the uncertainty calculation all tissue sensitivity values were calculated using a load impedance of 5 M Ω .

Boundary Effect:

FOR A DISTANCE OF 2.6MM THE EVALUATED UNCERTAINTY (INCREASE IN THE PROBE SENSITIVITY) IS LESS THAN 2%.



TEST EQUIPMENT

The test equipment used during Probe Calibration, manufacturer, model number and, current calibration status are listed and located on the main APREL server R:\NCL\Calibration Equipment\Instrument List May 2002



Appendix F

Dipole Calibration Certificate



NCL CALIBRATION LABORATORIES

Calibration File No: DC-0265

Project Number: Internal

CERTIFICATE OF CALIBRATION

It is certified that the equipment identified below has been calibrated in the
NCL CALIBRATION LABORATORIES by qualified personnel following recognized
procedures and using transfer standards traceable to NRC/NIST.

APREL Validation Dipole

Manufacturer: APREL Laboratories

Part number: D-2450-S-1

Frequency: 2.45 GHz

Serial No: ALCD-10

Customer: APREL

Calibrated: 15 November 2002
Released on: 14 November 2003

Released By: _____

NCL CALIBRATION LABORATORIES

51 SPECTRUM WAY
NEPEAN, ONTARIO
CANADA K2R 1E6

Division of APREL Lab.
TEL: (613) 820-4988
FAX: (613) 820-4161



7.0 CALIBRATION RESULTS SUMMARY

The following results relate the Calibrated Dipole and should be used as a quick reference for the user.

Mechanical Dimensions

Length: 51.7 mm
Height: 30.8 mm

Electrical Specification

SWR: 1.181U
Return Loss: -21.4 dB
Impedance: 46.175

System Validation Results

Frequency	1 Gram	10 Gram	Peak
2.45 GHz	52.45	22.91	102.91

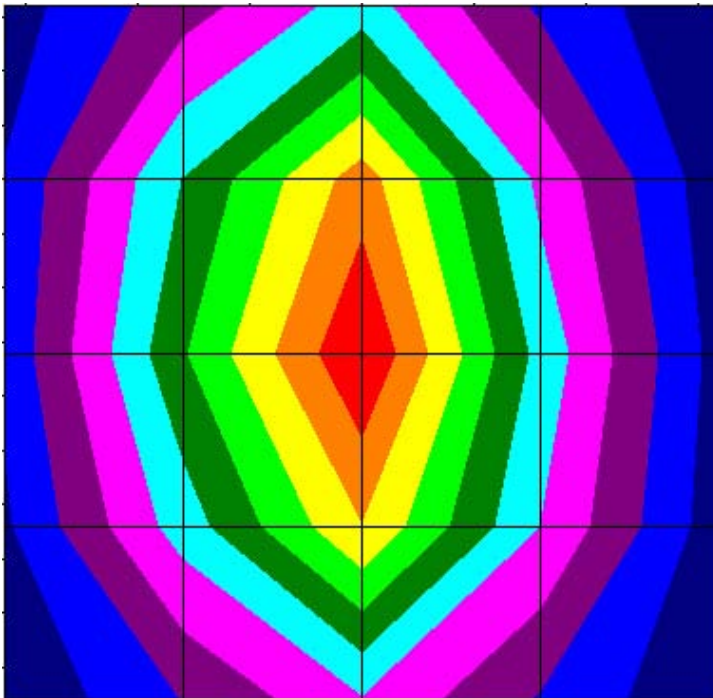

8.0 INTRODUCTION

This Calibration Report has been produced in line with the SSI Dipole Calibration Procedure SSI-TP-018. The results contained within this report are for Validation Dipole ALCD-10 at 2.45 GHz. The calibration routine consisted of a three-step process. Step 1 was a mechanical verification of the dipole to ensure that it meets the IEEE mechanical specification. Step 2 was an Electrical Calibration for the Validation Dipole, where the SWR, Impedance, and the Return loss were assessed. Step 3 involved a System Validation using the ALIDX-500, along with the APREL Reference E-010 130 MHz to 26 GHz E-Field Probe Serial Number 163.

9.0 REFERENCES

SSI-TP-018 Dipole Calibration Procedure
SSI-TP-016 Tissue Calibration Procedure
IEEE 1528 *DRAFT* "Recommended Practice for Determining the Peak Spatial-Average Specific Absorption Rate (SAR) in the Human Body Due to Wireless Communications Devices: Experimental Techniques"

Conditions

Dipole ALCD-10 was a new Dipole taken from stock prior to calibration.

Ambient Temperature of the Laboratory: 24 °C +/- 0.5°C
Temperature of the Tissue: 20 °C +/- 0.5°C

10.0 DIPOLE CALIBRATION RESULTS

Mechanical Verification

IEEE Length	IEEE Height	Measured Length	Measured Height
51.5 mm	30.4 mm	51.7 mm	30.8 mm

Tissue Validation

Head Tissue 2450 MHz	Measured
Dielectric constant, ϵ_r	39.2
Conductivity, σ [S/m]	1.82
Tissue Conversion Factor,	4.61

Electrical Calibration

Test	Result	IEEE Value
S11 R/L	-21.4	-21 dB
SWR	1.181U	-
Impedance	46.175 Ω	

The Following Graphs are the results as displayed on the Vector Network Analyzer.

S11 Parameter Return Loss

S11 FORWARD REFLECTION

LOG MAGNITUDE REF=0.000 dB 10.000 dB/DIV

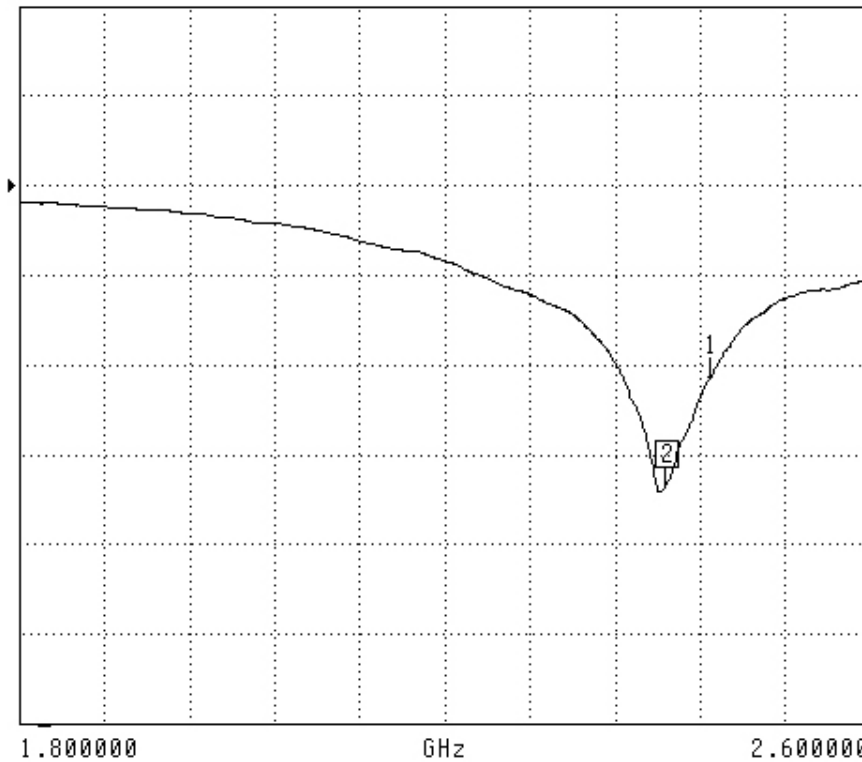

CH 1 - S11
REFERENCE PLANE
5.1160 mm

MARKER 2
2.408000 GHz
-33.566 dB

MARKER TO MAX
▶ MARKER TO MIN
1 2.450000 GHz
-21.377 dB

MARKER READOUT
FUNCTIONS



SWR

S11 FORWARD REFLECTION

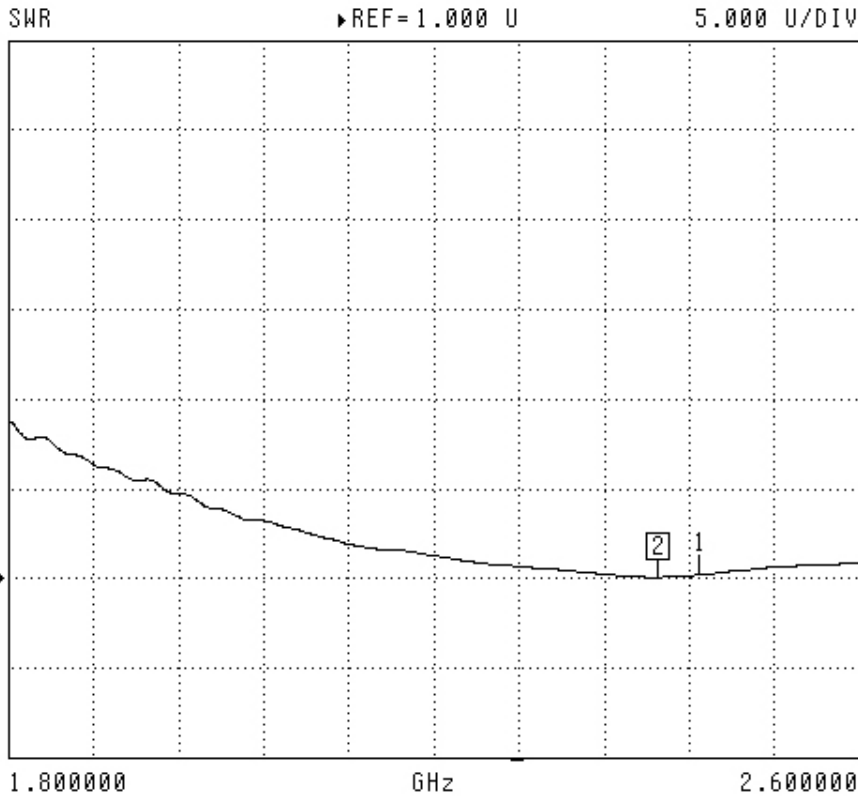

CH 1 - S11
REFERENCE PLANE
5.1160 mm

MARKER 2
2.411000 GHz
1.049 U

MARKER TO MAX
▶ MARKER TO MIN
1 2.450000 GHz
1.181 U

MARKER READOUT
FUNCTIONS



System Validation Results Using the Electrically Calibrated Dipole

Frequency	1 Gram	10 Gram	Peak Above Feed Point
2.45 GHz	52.45	22.91	102.91

The following Graphic Plot is the splined measurement result for the course scan.

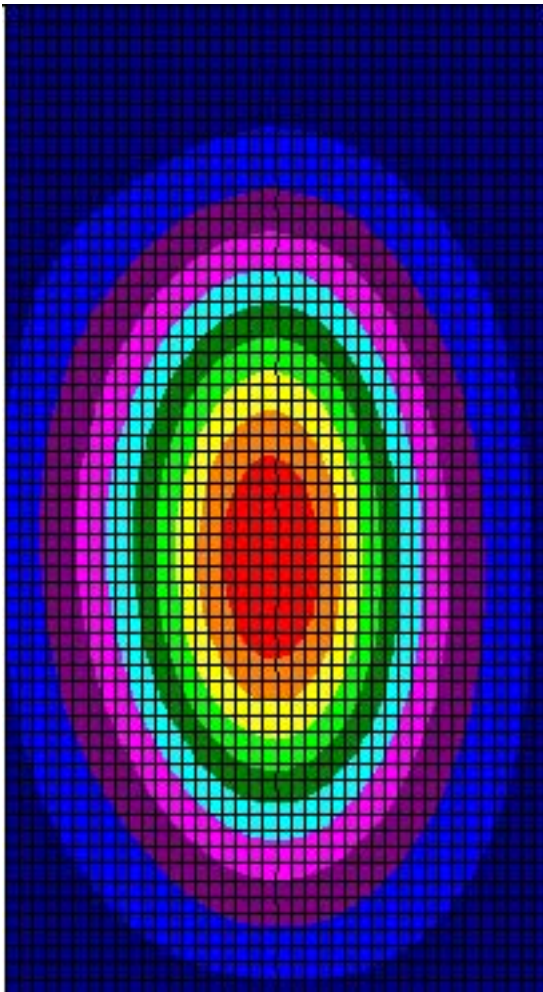

11.0 TEST EQUIPMENT

The test equipment used during Probe Calibration, manufacturer, model number and, current calibration status are listed and located on the main APREL server R:\NCL\Calibration Equipment\Instrument List May 2002

