

Experimental Analysis SAR Report

Subject: **Specific Absorption Rate (SAR) Hand and Body Report**

Product: Dell PP10L laptop

Model: PP10L

Client: Dell Computer Corporation

Applicant: Intel Corporation
Evening Creek Drive,
San Diego CA, 92128

Manufacturer: Dell

Project #: ITLB-Dell PP10L Laptop - 4055

Prepared by: APREL Laboratories
51 Spectrum Way
Nepean, Ontario
K2R 1E6

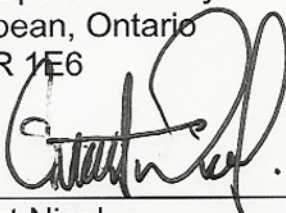

Approved by 
Stuart Nicol
Director Product Development, Dosimetric R&D

Date: 18-SEPTEMBER-03

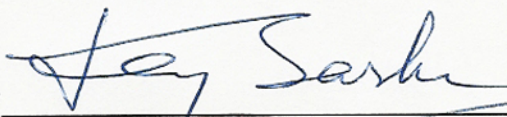
Submitted by 
Jay Sarkar
Technical Director of Standards & Certification

Date: Sept. 18, 2003

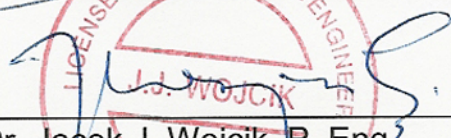
Released by 
Dr. Jacek J. Wojcik, P. Eng.

Date: Sept 18/03



Applicant: Intel Corporation
 Manufacturer: Dell Computer Corporation
 FCC ID: E2K24CLNS
 Equipment: Intel Mini PCI Type 3A 802.11b Wireless LAN Adapter model WM3A2100 located inside the Dell PP10L laptop
 Model: PP10L
 Serial Number: CRW3800141
 Received Status: Production Unit Pre-release
 Standard: FCC 96-326, Guidelines for Evaluating the Environmental Effects of Radio-Frequency Radiation

ENGINEERING SUMMARY

This report contains the results of the engineering evaluation performed on the Intel Mini PCI Type 3A 802.11b Wireless LAN Adapter model WM3A2100 located inside the Dell PP10L laptop. The analysis was carried out in accordance with the requirements of FCC 96-326, "Guidelines for Evaluating the Environmental Effects of Radio-Frequency Radiation" in accordance with Supplement C and, using methodologies contained within IEEE 1528. The Intel Mini PCI Type 3A 802.11b Wireless LAN Adapter model WM3A2100 located inside the Dell PP10L laptop was evaluated for compliance to the RF exposure requirements contained in section 2 "Applicable Documents". The Intel Mini PCI Type 3A 802.11b Wireless LAN Adapter model WM3A2100 while located inside the Dell PP10L laptop was assessed for SAR at the **maximum power level set** at 16.5dBm while operating with the **duty cycle set at 100%**.

The Intel Mini PCI Type 3A 802.11b Wireless LAN Adapter model WM3A2100 is located inside the Dell PP10L laptop and utilizes a Mini PCI type A form factor. The Intel Mini PCI Type 3A 802.11b Wireless LAN Adapter model WM3A2100 located inside the Dell PP10L laptop has been assessed for body, bystander, and direct contact SAR.

Intel provided APREL laboratories with one pre-production model of the Dell PP10L laptop. The Dell PP10L laptop can transmit while in laptop mode with the LCD open and also with the LCD closed. The Dell PP10L laptop has an internal set of diverse antennas manufactured by Winstron which are located at the top of the LCD. The main transmitting antenna is located at the **TOP Left hand Side of the LCD**.

For the purpose of the SAR analysis executed and subsequent report the Intel Mini PCI Type 3A 802.11b Wireless LAN Adapter model WM3A2100 located inside Dell laptop will not be labeled as the DUT (Device Under Test). **The DUT is the Dell PP10L laptop.**



The Intel Mini PCI Type 3A 802.11b Wireless LAN Adapter model WM3A2100 located inside the Dell PP10L laptop was evaluated for both body exposure and direct contact SAR (for extremities) at low (ch#1), middle (ch#6) and high (ch#11) for the frequency range of 2412MHz to 2462MHz. Tests were executed at zero mm separation distance, for both direct contact SAR (for extremities) and body SAR analysis.

The conservative 10g average for direct contact SAR for the DUT was found to be **0.28 W/kg for the peak RF output power of the mid channel (ch#6, $f_{TX}=2437\text{MHz}$)** at the front left side of the DUT with the Laptop in closed position, with the front side of Laptop facing up against the phantom at 0 mm separation. For body SAR analysis the conservative 1 g SAR was found to be **0.97 W/kg for the peak RF output power of the mid channel (ch#6, $f_{TX}=2437\text{MHz}$)** at the top side (edge) of the LCD, with the LCD in open position and the top edge of LCD facing up against the phantom at 0 mm separation.

Evaluation data and graphs are presented in this report. All analysis conducted and documented in this report were performed while the Intel Mini PCI Type 3A 802.11b Wireless LAN Adapter model WM3A2100 was located inside the Dell PP10L laptop.

For the purpose of the SAR assessment the AC power source was used, and the conservative SAR position and frequency for each of the Test Case Scenarios was reassessed using the battery supply. It was found that the conservative SAR presented in this report was measured while using the AC supply.

Based on the measured results and on how the Intel Mini PCI Type 3A 802.11b Wireless LAN Adapter model WM3A2100 while located inside the Dell PP10L laptop will be marketed and used, it is certified that the DUT meets the requirements as set forth in the specifications, for the RF exposure environment contained within this report.

The results presented in this report relate only to the sample evaluated.



TABLE OF CONTENTS

ENGINEERING SUMMARY 2

1. Introduction 5

2. Applicable Documents 5

3. Test Case Scenarios..... 6

4. Test Equipment..... 9

 4.1 E-010 Isotropic E-Field Probe 10

5. SET Up 12

6. Test Results..... 19

 6.1. TRANSMITTER CHARACTERISTICS..... 19

 6.2. SAR MEASUREMENTS 20

 6.3. DIRECT CONTACT SAR..... 21

 6.4. BODY EXPOSURE..... 22

7. Conclusions 24

Appendix A: Graphic Plots FROM SAR Measurements 24

Appendix B: Pictures of the evaluation setup 49

Appendix C: Validation Scan 56

Appendix D: Uncertainty Budget..... 59

Appendix E: Probe Calibration Certificate 60

Appendix F: Dipole Calibration Certificate 71



1. INTRODUCTION

Tests were conducted to determine the Specific Absorption Rate (SAR) for a sample Intel Mini PCI Type 3A 802.11b Wireless LAN Adapter model WM3A2100 located inside the Dell PP10L laptop. These tests were conducted at APREL Laboratories facility located at 51 Spectrum Way, Nepean, Ontario, Canada.

2. APPLICABLE DOCUMENTS

The following documents are applicable to the evaluation performed:

- 1) FCC 96-326, Guidelines for Evaluating the Environmental Effects of Radio-Frequency Radiation
- 2) ANSI/IEEE C95.1-1999, IEEE Standard for Safety Levels with Respect to Human Exposure to Radio Frequency Electromagnetic Fields, 3 kHz to 300 GHz.
- 3) ANSI/IEEE C95.3-1992, IEEE Recommended Practice for the Measurement of Potentially Hazardous Electromagnetic Fields – RF and Microwave.
- 4) OET Bulletin 65 (Edition 97-01) Supplement C (Edition 01-01), “Evaluating Compliance with FCC Guidelines for Human Exposure to Radio Frequency Electromagnetic Fields”.
- 5) IEEE 1528 “Recommended Practice for Determining the Peak Spatial Average Specific Absorption Rate (SAR) in the Human Body Due to Wireless Communication Devices: Experimental Techniques.”



3. Test Case Scenarios

Intel provided APREL Laboratories with a sample laptop which acts as the host for the Intel Mini PCI Type 3A 802.11b Wireless LAN Adapter model WM3A2100 for the purpose of the SAR evaluation. The evaluations performed on the Intel Mini PCI Type 3A 802.11b Wireless LAN Adapter model WM3A2100 while located inside the Dell PP10L laptop were to establish the conservative SAR value for both 1 and 10g averages while the Mini PCI card was transmitting at the maximum power level set below the amplifier saturation point.

The DUT (device under test) is the Dell PP10L laptop that uses the Intel Mini PCI Type 3A 802.11b Wireless LAN Adapter model WM3A2100.

Device Tested Laptop Configuration



Dell PP10L laptop

Device Tested Back Side

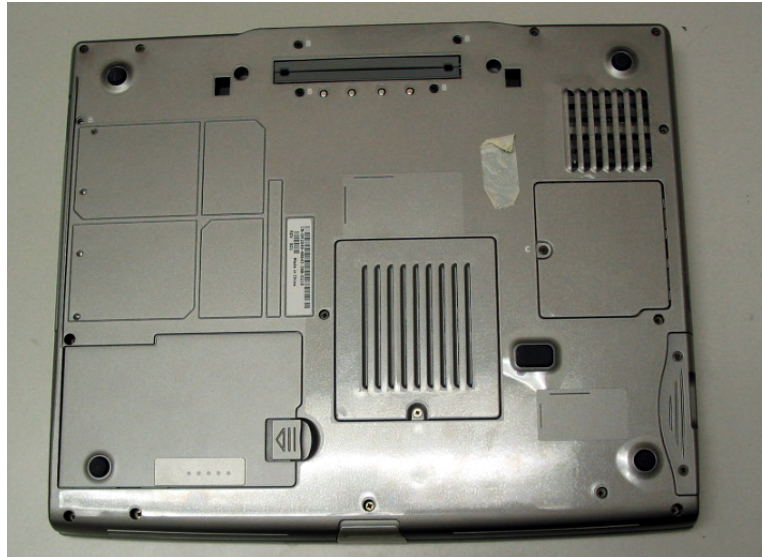

Dell PP10L laptop

Device Tested Front Side



Dell PP10L laptop

Device Tested Left Side



LCD Front Side

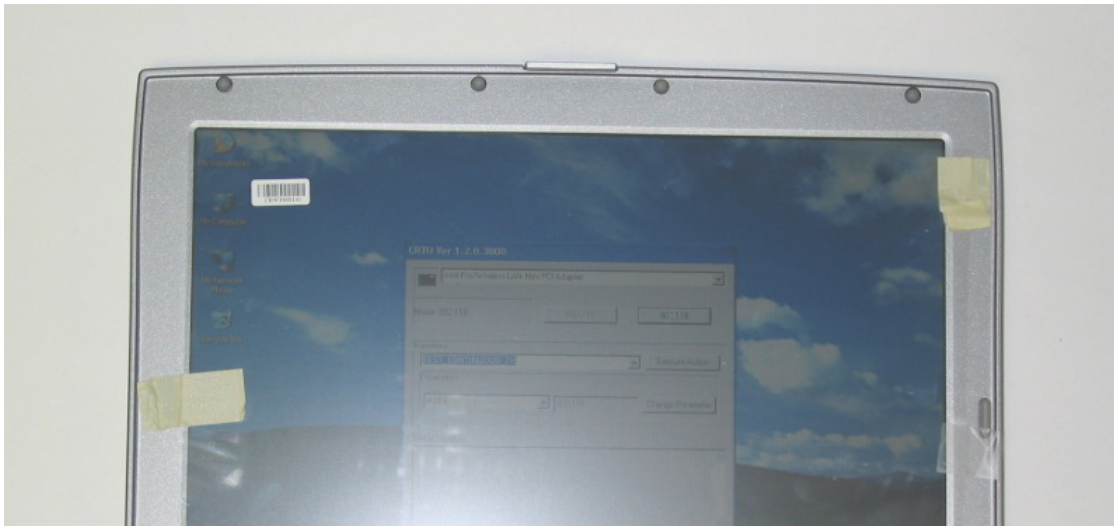

LCD Top Side



4. TEST EQUIPMENT

- APREL Triangular Dosimetric Probe Model E-010, s/n 163
- ALIDX-500 Dosimetric SAR Measurement System
- APREL flat Phantom F1, Part # P-V-G8 (overall shell thickness 2mm)
- APREL 2.45GHz Dipole
- APREL RF Amplifier
- Hewlett Packard Signal Generator Asset
- Rohde & Schwarz RF Power Meter
- Rohde & Schwarz RF Power Sensor
- Hewlett Packard Dual Directional Coupler

Table 2: Instrumentation

Instrument	Calibration Due	Asset Number/Serial Number
E-010 Probe	May 2004	163
ALIDX-500	March 2004	N/A
APREL Flat Phantom	N/A	APL-001
APREL UniPhantom	N/A	APL-085
APREL 2450MHz Dipole	CBT	N/A
APREL RF Amplifier	CBT	301467
HP-Signal Generator	September 2004	301468
R & S RF Power Meter	October 2003	100851
R & S RF Power Sensor	October 2003	301461
HP Directional Coupler	October 2003	100251



4.1 E-010 Isotropic E-Field Probe

The E-field probe used by APREL Laboratories, has been fully calibrated and assessed for isotropicity, and boundary effect. The probe utilizes a triangular sensor arrangement as detailed in the diagram below.

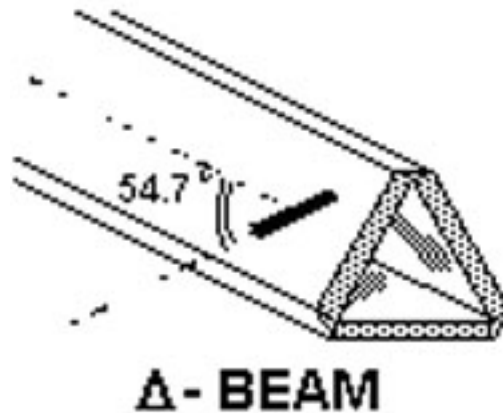

The SAR is assessed with the probe which moves at a default height of 5mm from the centre of the diode, which is mounted to the sensor, to the phantom surface (Z height). The diagram below shows how the centre of the sensor is defined with the location of the diode placed at the centre of the dipole. The 5mm default in the Z axis is the optimum height for assessing SAR where the boundary effect is at it least, with the probe located closest to the phantom surface (boundary).

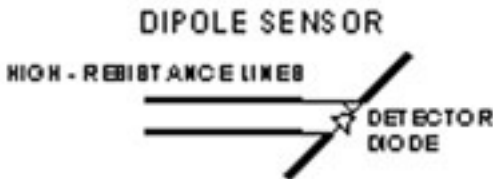

During the cube scan assessment, the probe is positioned in 5 x 8mm steps in both the X, and Y axis, and 7 x 5mm steps for the Z axis. The total size for the physical cube used during the averaging assessment is 32mm x 32mm x 35mm.