

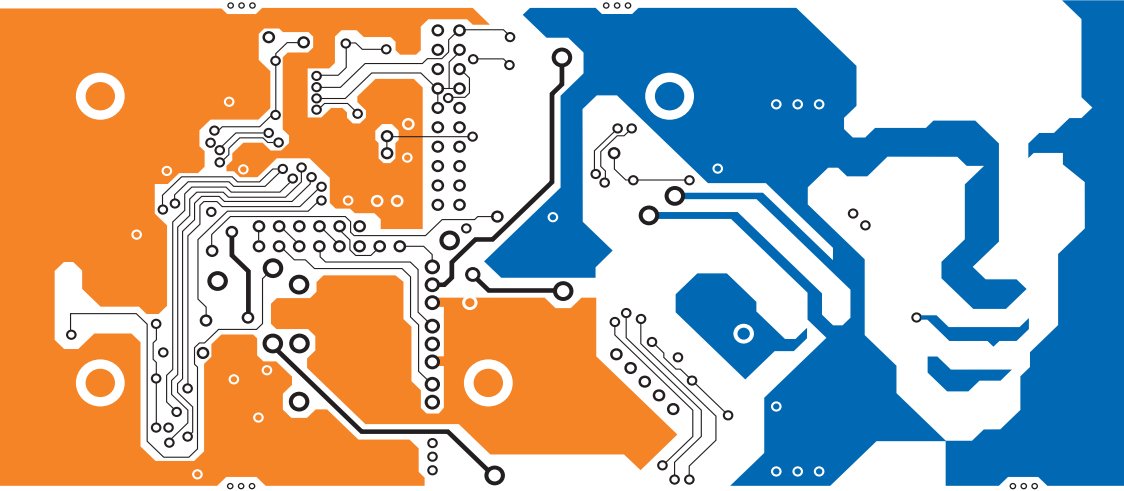

Power Amplifier

3160

HF RADIO COMMUNICATIONS



INSTALLATION HANDBOOK

No part of this handbook may be reproduced, transcribed, translated into any language or transmitted in any form whatsoever without the prior written consent of Codan Limited.

© Copyright 2008, 2009 Codan Limited.

Codan part number 15-04157-EN Issue 2, February 2009

Brand, product, and company names mentioned in this document are trademarks or registered trademarks of their respective holders.

The English version takes precedence over any translated versions.

Introduction

1 Overview

General	4
Power supply options	6
Typical layouts	8
Care and safety guidelines	13
Compatibility	14

2 Installing the 3160

Disclaimer	16
What you need to consider	17
Basic layout	17
Stacked layout	18
Mobile station	18
Fixed station	20
Mounting	20
Grounding	20
Installing the 3160 in a basic layout	21
Installing the 3160 in a stacked layout	22
Attaching the 2110 amplifier adaptor panel to the rear of the transceiver cradle	24
Attaching the 3160, voltage regulator and external speaker to a mounting surface	26
Attaching a suitable power supply to the power supply cover	27
Attaching the power amplifier mounting bracket to the transceiver cradle	27
Attaching the 3160 and external speaker to the power amplifier mounting bracket	31
Connecting the equipment	33
Setting up the transceiver	34

Grounding the 3160 34
Installing the station 35

3 Specifications

4 Accessories

Appendix A—Connectors

Appendix B—Compliance

Introduction 46
European R&TTE Directive 46
EMC and safety notices 47
C-tick approval 48
FCC compliance 49
 FCC Part 90 certification 49
 FCC Part 15 compliance 49
 Compliance with RF exposure standards 50
 Operating instructions to control RF exposure 50
 Mobile antennas 51
 Approved accessories 51
 Contact information 51
IC approval 52
Register of hazardous substances 53

Appendix C—Definitions

Standards and icons 55
Acronyms and abbreviations 56
Glossary 57
Units 58
Unit multipliers 59
About this issue 60

Index

List of figures



Figure 1:	3160 Power Amplifier	4
Figure 2:	Power supply from a 3020 Transceiver Supply	6
Figure 3:	Power supply from a 12 V battery	7
Figure 4:	Power supply from a 24 V battery via a voltage regulator	7
Figure 5:	Basic layout	10
Figure 6:	Stacked layout	12
Figure 7:	Process for installing the 3160 in a basic layout	21
Figure 8:	Process for installing the 3160 in a stacked layout.	23
Figure 9:	2110 amplifier adaptor panel and cradle	24
Figure 10:	Power supply cover, cradle, and power amplifier mounting bracket	28
Figure 11:	Power supply cover, cradle, power amplifier mounting bracket, interface adaptor, and coaxial cable	29
Figure 12:	Holes in the power amplifier mounting bracket.	31
Figure 13:	3160 and power amplifier mounting bracket	32
Figure 14:	Dimensions.	39
Figure 15:	Front view of the 12-way connector on the 3160.	43
Figure 16:	Front view of the 6-way connector on the 2110 amplifier adaptor panel.	44

This page has been left blank intentionally.

List of tables



Table 1:	Functional specifications	37
Table 2:	Dimensions	39
Table 3:	Weights for accessories	40
Table 4:	Accessories for the 3160 Power Amplifier	41
Table 5:	Pinouts for the 12-way connector on the 3160	43
Table 6:	Pinouts for the 6-way connector on the 2110 amplifier adaptor panel	44
Table 7:	有毒有害物质列表 (Register of hazardous substances)	53

This page has been left blank intentionally.

This handbook is for installers of the 3160 Power Amplifier. It assumes that you have experience in installing RF equipment.

This handbook contains the following sections:

- Section 1 Overview**—provides an overview of the 3160, typical layouts, care and safety, and compatibility
- Section 2 Installing the 3160**—provides guidance on how to position, install, and earth the 3160
- Section 3 Specifications**—provides the common operational, environmental, and physical specifications of the 3160
- Section 4 Accessories**—lists the accessories available for the 3160
- Appendix A Connectors**—provides the pinouts for Codan-specific connectors
- Appendix B Compliance**—provides compliance information and safety notices for the 3160
- Appendix C Definitions**—explains the terms and abbreviations used in this handbook

There is an index at the end of this handbook.

This page has been left blank intentionally.

1 Overview



This section contains the following topics:

General (4)

Power supply options (6)

Typical layouts (8)

Care and safety guidelines (13)

Compatibility (14)

General

The 3160 Power Amplifier is designed to provide 125 W transmitting power for a 2110M or 2110 Manpack Transceiver. The 3160 provides 12 V DC to the transceiver from a suitable power source. When the 3160 is connected into the transceiver system, it is automatically detected when the transceiver is switched on.

NOTE A 100 W option is available.

NOTE For information on hardware and software compatibility requirements see [page 14](#), *Compatibility*.

Figure 1: 3160 Power Amplifier

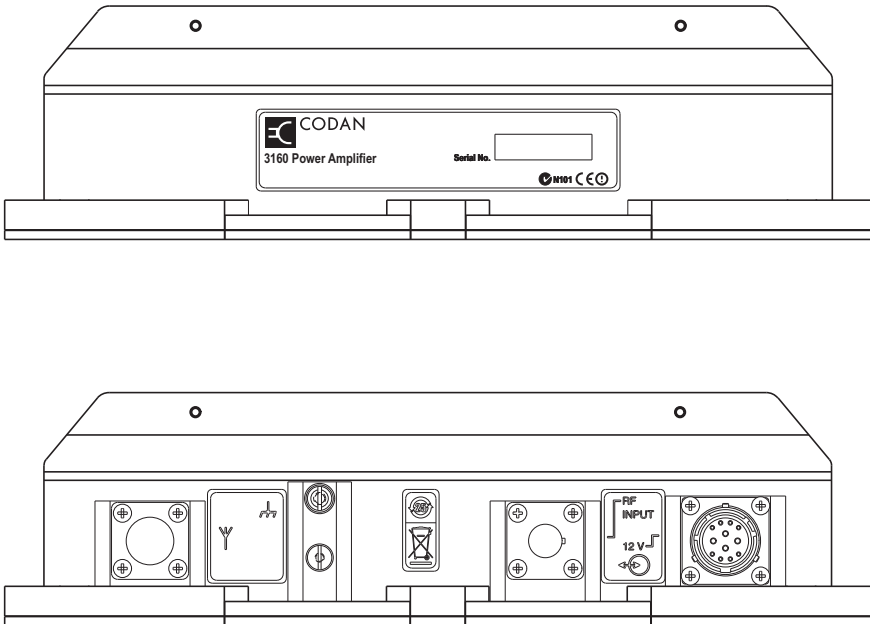

A typical 3160 Power Amplifier installation comprises:

- a 2110M Manpack Transceiver (build standard A or later), or a 2110 Manpack Transceiver (build standard H or later) with firmware V4.91 or later
- a 3160 Power Amplifier
- a 2110 series Manpack Transceiver cradle with interface adaptor and external speaker
- a 2110 amplifier adaptor panel
- a power adaptor cable
- a coaxial cable
- a 12 V DC power source with appropriate cables
- an antenna system with appropriate cables and power rating
- a grounding system

Optional equipment for the system includes:

- a power amplifier mounting bracket
- a power supply cover
- a fan
- an external antenna tuner

Power supply options

The 3160 Power Amplifier requires a 12 V DC supply. This may be supplied by one of the following sources:

- 3020 Transceiver Supply (fixed station only; this requires connection to the AC mains supply)
- 12 V DC vehicle battery (see [Figure 3 on page 7](#))
- 24 V DC vehicle battery via a 24 V to 12 V voltage regulator (see [Figure 4 on page 7](#))

NOTE You can mount the 3020 Transceiver Supply or the voltage regulator within a power supply cover (Codan part number 15-00147).

Figure 2: Power supply from a 3020 Transceiver Supply

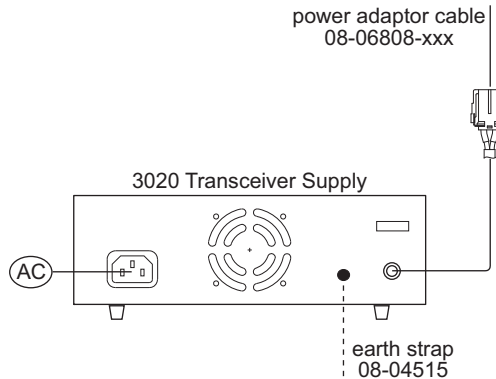

Figure 3: Power supply from a 12 V battery

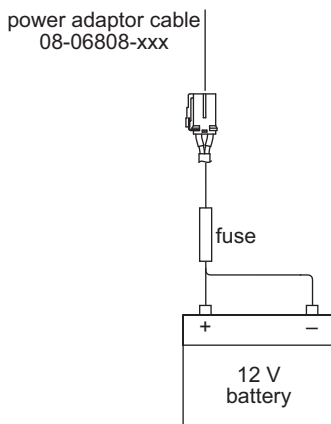
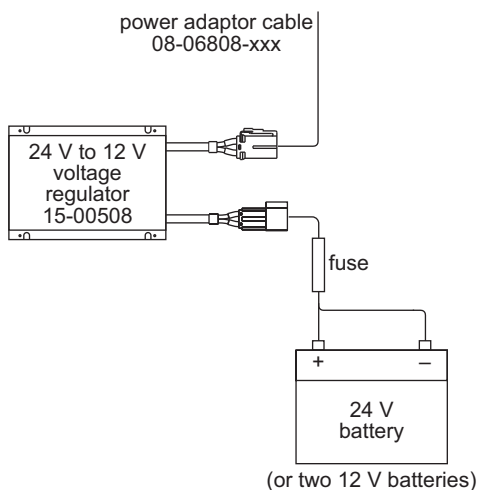

Figure 4: Power supply from a 24 V battery via a voltage regulator



Typical layouts

The 2110M or 2110 Manpack Transceiver and a 3160 Power Amplifier may be installed in a mobile station or a fixed station.

The equipment may be arranged in one of two layouts:

- basic layout, in which items are located separately and bolted down, if required (see [Figure 5 on page 10](#))
- stacked layout, in which all items are bolted together in a stack using a mounting bracket, and optional power supply cover (see [Figure 6 on page 12](#))

A 2110 amplifier adaptor panel (supplied with the 3160) is attached to the rear of the 2110 cradle. When the manpack transceiver is inserted into the cradle, it connects with the 2110 amplifier adaptor panel. A special power adaptor cable connects the 2110 amplifier adaptor panel to the 3160 and an appropriate 12 V DC power source. A coaxial cable connects the antenna output from the **1** connector on the front panel of the transceiver to the **RF INPUT** connector on the 3160. The RF output from the 3160 is sent to an antenna system via a coaxial cable connected to the **Y** connector.

WARNING In a mobile station, all items must be bolted securely to rigid structures within the vehicle. For more information on these requirements see [page 15, *Installing the 3160*](#).

NOTE For information on suitable power sources see [page 6, *Power supply options*](#).

Basic layout

The basic layout is shown in [Figure 5](#). It includes:

- a 2110M or 2110 Manpack Transceiver
- a 3160 Power Amplifier
- a 2110 series Manpack Transceiver cradle with interface adaptor and external speaker
- a 2110 amplifier adaptor panel
- a power adaptor cable
- a coaxial cable
- a suitable 12 V DC supply

Figure 5: Basic layout

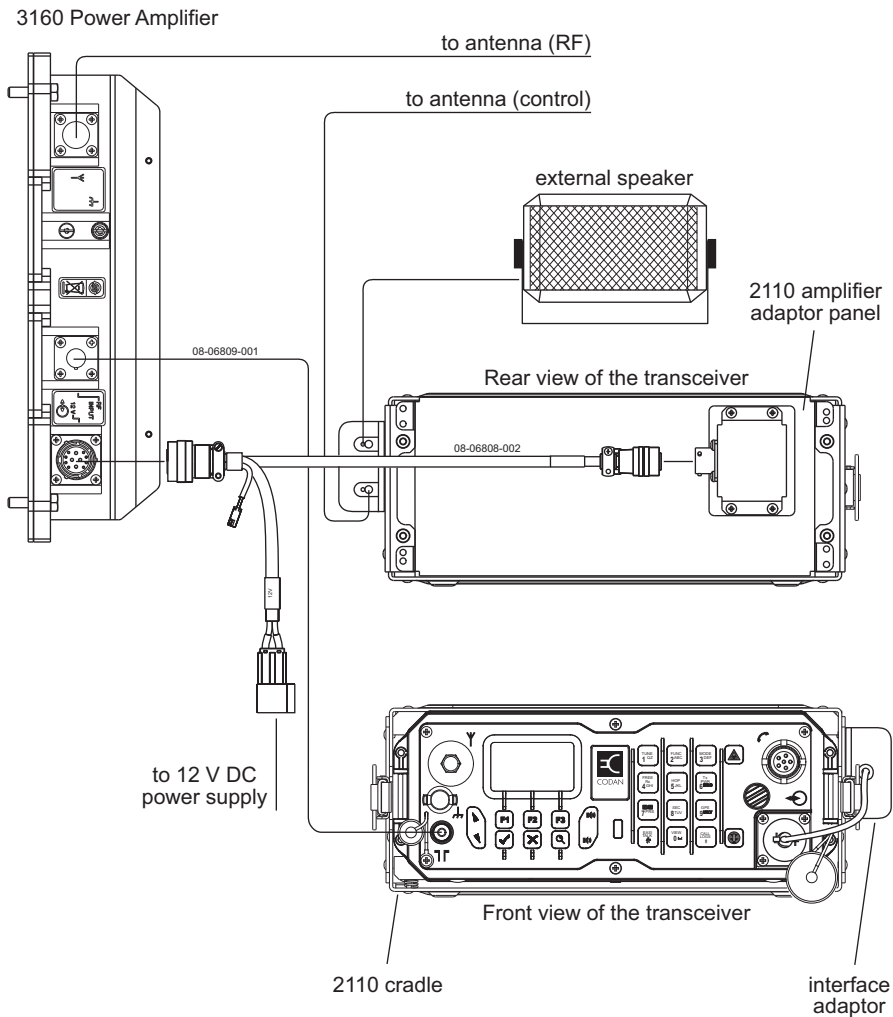

Stacked layout

CAUTION Please read the installation process before assembling the stacked layout (see [Figure 8 on page 23](#)).

The stacked layout is shown in [Figure 6](#). It includes:

- a 2110M or 2110 Manpack Transceiver
- a 3160 Power Amplifier
- a 2110 series Manpack Transceiver cradle with interface adaptor and external speaker
- a 2110 amplifier adaptor panel
- a power adaptor cable
- a coaxial cable
- a suitable 12 V DC supply
- a power amplifier mounting bracket (includes long screws for attaching the interface adaptor to the cradle)
- a power supply cover (includes transceiver supply brackets and various captive nuts, screws and washers) (optional)

Figure 6: Stacked layout

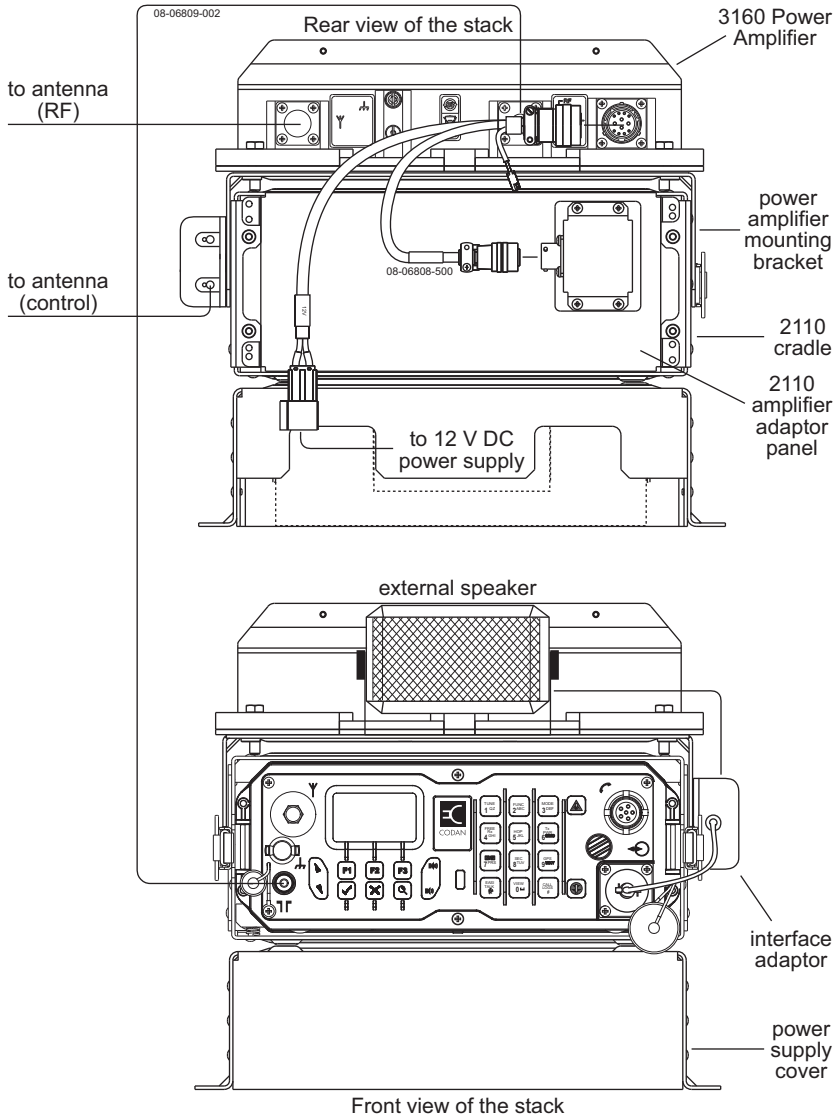

Care and safety guidelines

The following guidelines are intended for best performance of the equipment and operator safety:

- Ensure that the 3160 and manpack transceiver are in a well-ventilated area.
- Check the mounting points regularly if the installation is subject to continuous vibration.
- Ensure that the installation is grounded to a suitable earth point.
- Check the safe working distance for the type of antenna you are using at 125 W output.

Compatibility

The following hardware build standards are required for operation with the 3160:

Transceiver type	Build standard
2110M Manpack Transceiver	A or later
2110 Manpack Transceiver	H or later

Both types of transceiver must have firmware V4.91 or later.

NOTE The build standard is indicated by the 8th character in the serial number of the transceiver. The serial number is located under the bar code.

Upgrades are available for the hardware and firmware. Please contact your Codan representative for more information.

2 Installing the 3160



This section contains the following topics:

Disclaimer (16)

What you need to consider (17)

Installing the 3160 in a basic layout (21)

Installing the 3160 in a stacked layout (22)

Attaching the 2110 amplifier adaptor panel to the rear of the transceiver cradle (24)

Attaching the 3160, voltage regulator and external speaker to a mounting surface (26)

Attaching a suitable power supply to the power supply cover (27)

Attaching the power amplifier mounting bracket to the transceiver cradle (27)

Attaching the 3160 and external speaker to the power amplifier mounting bracket (31)

Connecting the equipment (33)

Setting up the transceiver (34)

Grounding the 3160 (34)

Installing the station (35)

Disclaimer

WARNING The 3160 Power Amplifier should be installed by a suitably qualified technician, to the relevant standards and approvals.

While the following instructions are intended to assist with installation, it is the purchaser's responsibility to ensure that the 3160 is installed with due regard to vehicle-occupant safety, particularly in the event of a vehicle accident.

WARNING Codan accepts no responsibility or liability in the event of injury to vehicle occupants or any other damage due to insecure or otherwise unsafe or inappropriate installation of the 3160.

What you need to consider

There are different requirements that must be considered, depending on the layout and type of station in which the 3160 is used, that is, basic or stacked layout, mobile or fixed station. Please read the sections that are relevant to your installation.

Basic layout

When installing the 3160 you must consider:

- the location and mounting of the 3160
- the routing of the coaxial and control cables
- grounding requirements for the 3160

The basic layout (see [Figure 5 on page 10](#)) is connected using a 2 m power adaptor cable between the 2110 amplifier adaptor panel (and hence the transceiver cradle) and the 3160.

Therefore, these items need to be located within 2 m of each other. For dimensions of each item see [page 37](#), *Specifications*.

The fins on the heatsink of the 3160 should be oriented so that warm air can move easily away from the fins. Ideal orientations for the 3160 are shown in [Figure 5 on page 10](#) and [Figure 6 on page 12](#).

Stacked layout

The stacked layout (see [Figure 6 on page 12](#)) provides a mounting system that connects all items together in a rugged stack.

CAUTION The stacked layout must be assembled in a specific order, as some holes become hidden during the assembly process. For more information see [page 22, *Installing the 3160 in a stacked layout.*](#)

For overall dimensions of the stack see [Figure 14 on page 39](#).

NOTE The power supply cover is not required if the system is powered from a 12 V DC vehicle battery.

Mobile station

The 3160 should be mounted in a location that:

- is clear of surrounding body work
- does not interfere with car openings
- provides adequate air flow around the unit

The 3160 must have:

- a strong anchorage point
- a sound electrical connection to the vehicle chassis

For specific instructions on mounting a vehicle cradle see the fitting instruction provided with the cradle.

Cabling in a vehicle

The coaxial cable between the antenna and the 3160 should be installed as far as possible from other vehicle wiring, especially high-voltage ignition wiring or the engine management computer.

The cabling must be in a position that:

- is away from the driver's feet
- is secured and concealed as much as possible
- ensures the control and coaxial cables are separated from the DC power cable by at least 200 mm (8 in) (except over short distances, for example, to pass through the same hole in a bulkhead)
- is secured behind protective metalwork (only if the cables run under the vehicle)

Keep cables in the engine compartment away from:

- heat, for example, exhaust, air-conditioning systems, and water pipes
- oils and corrosive liquids, for example, engine oil, battery fluid, and brake fluid

Protect all the cables from sharp edges and mechanical abrasions. Cables that pass through body panels or internal bulkheads must be protected by rubber grommets. Holes in the bulkhead need only be large enough to allow the end of the cable with the smaller connector to pass through. Removing a connector should be a last resort.

CAUTION Removal of factory-fitted connectors may cause cable or connector faults.

CAUTION Crimp-style coaxial connectors are not suitable for external locations because they are susceptible to mechanical damage and are not weatherproof.

NOTE Any cabling under carpet or floor mats should be clear of foot traffic.

Fixed station

There are no specific requirements for locating the transceiver and 3160 in a fixed station.

Mounting

The installed 3160 should enable easy access to the connectors. The 3160 should be positioned with the fins on the heatsink pointing upwards (as in the stacked layout), or if mounted on a vertical surface, with the fins on the heatsink running vertically (see [Figure 5 on page 10](#)).

In a mobile station, attach all items of the 3160 system to structural components of the vehicle.

WARNING Do not attach any items to loose or plastic panels in a vehicle.

Grounding

The 3160 Power Amplifier must be grounded using an earth strap (08-04515-001). In a mobile station, this strap must be connected to the vehicle chassis. For more information see [page 34, *Grounding the 3160*](#).

Installing the 3160 in a basic layout

The basic layout uses the transceiver cradle and 2110 amplifier adaptor panel, but does not use any mounting brackets. For more information see [Figure 5 on page 10](#).

Figure 7: Process for installing the 3160 in a basic layout

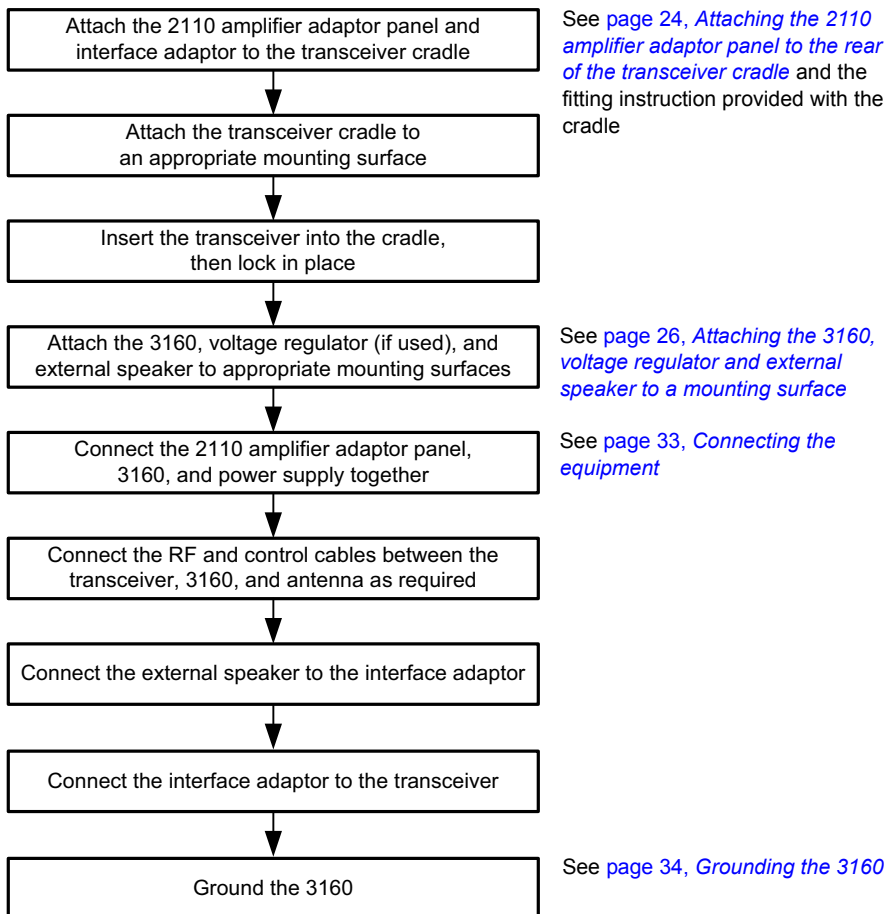

NOTE The rear of the transceiver cradle and the 3160 must be within 2 m of each other.

WARNING If this layout is installed in a mobile station, all items must be attached to appropriate mounting surfaces according to the relevant standards and approvals.

Installing the 3160 in a stacked layout

The stacked layout uses a power amplifier mounting bracket to attach the 3160 and external speaker to the transceiver cradle. For more information see [Figure 6 on page 12](#).

NOTE The power supply cover is not required if the 3160 is connected directly to a 12 V DC battery.

Figure 8: Process for installing the 3160 in a stacked layout

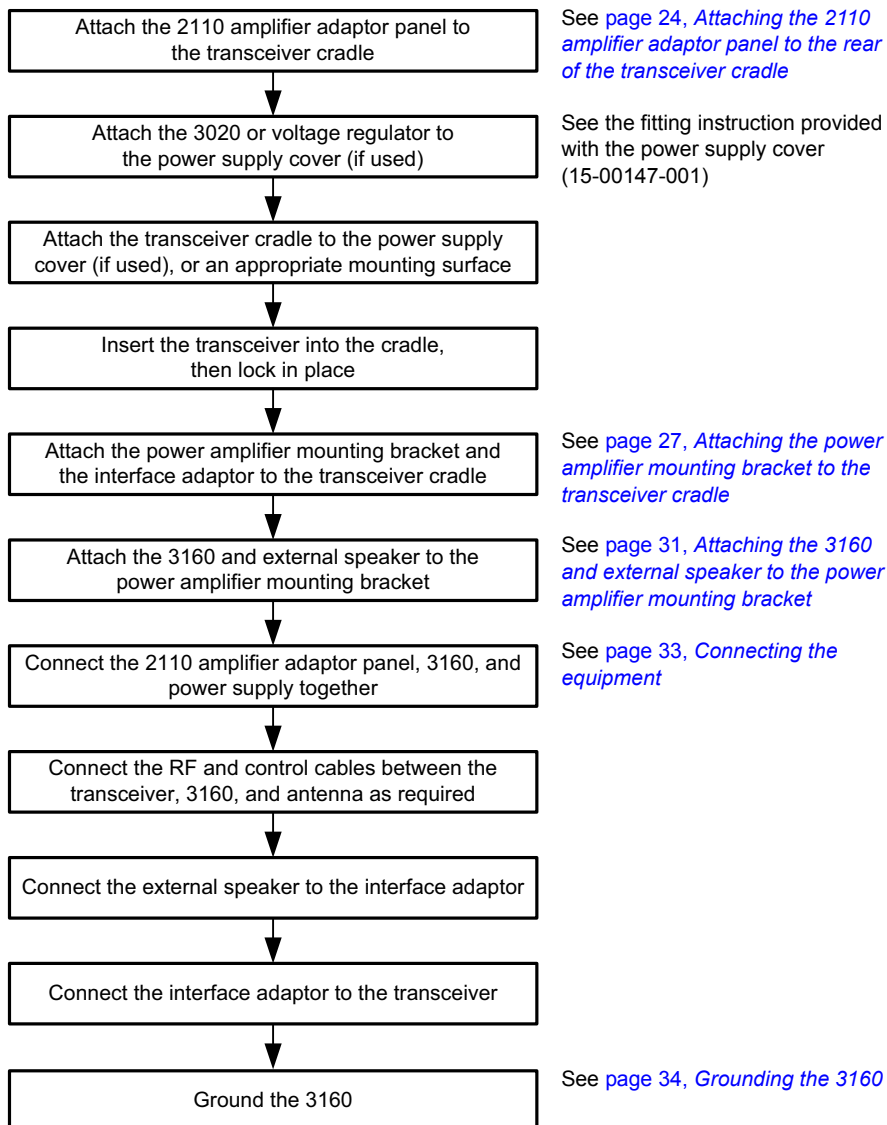

Attaching the 2110 amplifier adaptor panel to the rear of the transceiver cradle

To attach the panel to the cradle:

- Place the cradle with the mounting domes facing down.

NOTE If you are mounting the cradle in a basic layout, orientate the cradle so that it meets your requirements.

- Position the 2110 amplifier adaptor panel as shown in [Figure 9](#).

Figure 9: 2110 amplifier adaptor panel and cradle

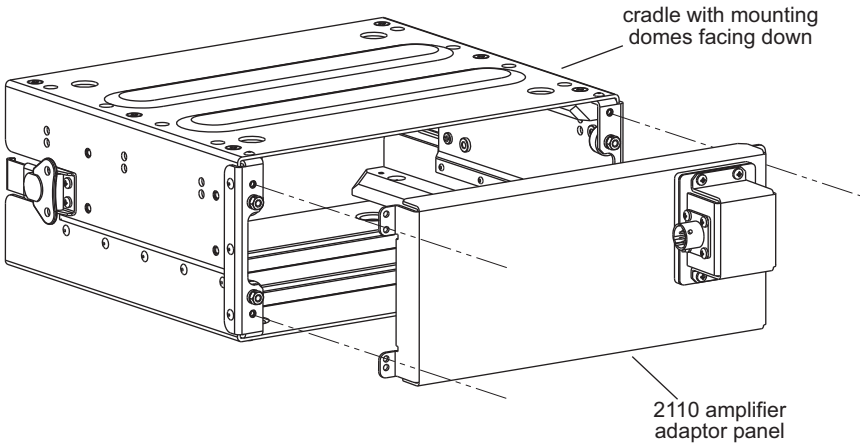

- Attach the 2110 amplifier adaptor panel to the rear of the cradle using the four M3 × 12 mm long, black, stainless steel, pan pozi screws provided.

If you are using a...**Continue from...**

Basic layout	Without power supply cover	page 26, <i>Attaching the 3160, voltage regulator and external speaker to a mounting surface</i>
Stacked layout	With power supply cover	page 27, <i>Attaching a suitable power supply to the power supply cover</i>
	Without power supply cover	page 27, <i>Attaching the power amplifier mounting bracket to the transceiver cradle</i>

Attaching the 3160, voltage regulator and external speaker to a mounting surface

To attach the 3160, voltage regulator, and speaker to a mounting surface:

- Position the 3160 on a suitable mounting surface with the fins either facing upwards or running vertically, and the connectors easily accessible.
- Do one of the following:
 - Attach the 3160 to the mounting surface using a 12AB × 25 mm long, self-tapping, pan pozi screw in each of the holes in the flanges of the 3160.
 - Attach the 3160 to the mounting structure using an M6 × 25 mm long, stainless steel Hex screw with an M6 stainless steel spring washer, and M6 stainless steel hex nut in each of the holes in the flanges of the 3160.
- Attach the voltage regulator to a suitable mounting surface using appropriate screws, washers, and nuts as required.
- Attach the mounting cradle of the speaker to the mounting surface with appropriate screws, washers, and nuts as required.
- Attach the speaker to the mounting cradle with the two thumb screws and rubber washers provided.
- Continue from [page 33, *Connecting the equipment*](#).

Attaching a suitable power supply to the power supply cover

The power supply cover is an optional item of equipment that is supplied with its own fitting instructions. For information on power supply options see [page 6, Power supply options](#). Please read Fitting Instruction 15-00147-001 for information on installing this item correctly.

NOTE If the mobile station is connected directly to a 12 V DC vehicle battery, the power supply cover is not required.

Attaching the power amplifier mounting bracket to the transceiver cradle

CAUTION The transceiver cradle must be attached to the power supply cover or a suitable mounting structure before attaching the power amplifier mounting bracket. When the mounting bracket is in place, the access holes for mounting the transceiver cradle are covered. For more information see the fitting instructions provided with the cradle and power supply cover.

WARNING All items must be mounted according to relevant standards and approvals.

To attach the mounting bracket to the cradle:

- Position the power amplifier mounting bracket over the top of the transceiver cradle (see [Figure 10](#)).

Figure 10: Power supply cover, cradle, and power amplifier mounting bracket

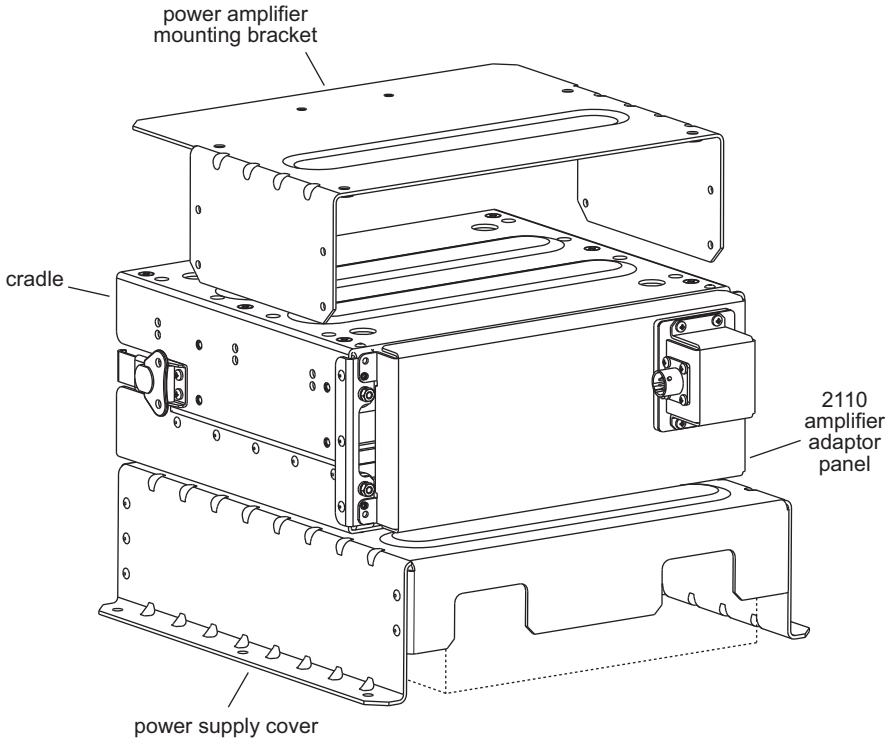

- Insert the coaxial cable (08-06809-002) into the two P-clips provided.
- Position the interface adaptor on the side of the power amplifier mounting bracket (see [Figure 11](#)).

Figure 11: Power supply cover, cradle, power amplifier mounting bracket, interface adaptor, and coaxial cable

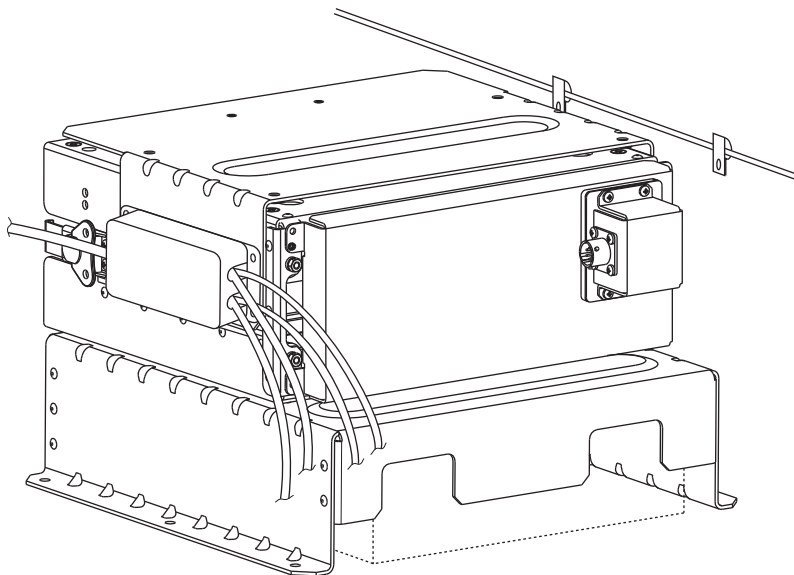

- ❑ Align the holes in the flanges of the interface adaptor with the holes in the power amplifier mounting bracket and the cradle.

NOTE

Lift the mounting bracket to align the holes with those on the transceiver cradle.

- ❑ Insert an M4 × 12 mm long, black, stainless steel, pan pozi screw into each of the holes for the interface adaptor and power amplifier mounting bracket, then screw these one turn into the transceiver cradle.
- ❑ On the other side of the cradle, insert an M4 × 12 mm long, black, stainless steel, pan pozi screw into each of the P-clips, passing these through the power amplifier mounting bracket into the transceiver cradle.

- Insert an M4 × 8 mm long, black, stainless steel, pan pozi screw into the remaining holes in the power amplifier mounting bracket to attach it to the transceiver cradle.
- Tighten all screws.

Attaching the 3160 and external speaker to the power amplifier mounting bracket

The power amplifier mounting bracket has two sets of holes drilled in the top.

Figure 12: Holes in the power amplifier mounting bracket

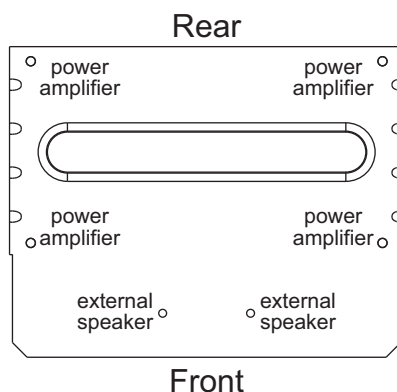

To attach the 3160 and speaker to the bracket:

- Position the 3160 on top of the power amplifier mounting bracket, with the connectors facing toward the rear of the transceiver cradle (see [Figure 13](#)).

Figure 13: 3160 and power amplifier mounting bracket

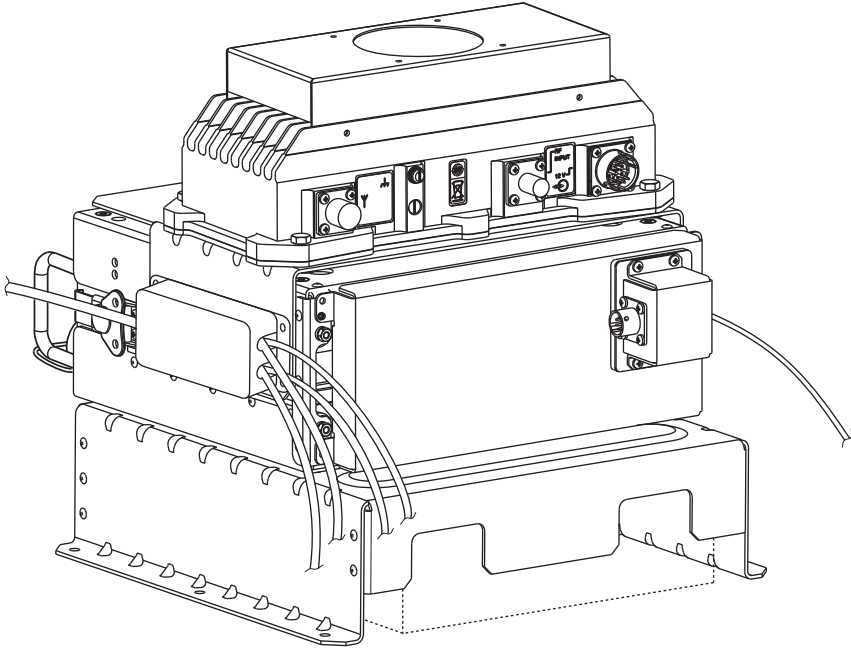

- ❑ Attach the 3160 to the bracket using an M5 × 20 mm long, black, stainless steel, pan pozi screw through each hole in the flanges of the 3160 into the captive nut in the bracket.
- ❑ Attach the mounting cradle of the speaker to the power amplifier mounting bracket using an M4 × 6 mm long, stainless steel, pan pozi screw through each hole in the cradle into the captive nut in the bracket.
- ❑ Attach the speaker to the mounting cradle with the two thumb screws and rubber washers provided.

Connecting the equipment

The equipment is connected the same, regardless of the layout that is used. The length of each cable used may vary depending on the layout. See [Figure 5 on page 10](#) and [Figure 6 on page 12](#) for more information.

To connect the equipment:

- Connect the 12-way connector on the power adaptor cable (08-06808-xxx) to the **12 V** connector on the 3160.
- Connect the 6-way connector on the power adaptor cable to the connector on the 2110 amplifier adaptor panel.
- Connect the BNC–BNC coaxial cable (08-06809-xxx) between the **⌋** connector on the front panel of the transceiver and the **RF INPUT** connector on the 3160.
- Connect the **12 V** connector on the power adaptor cable to a suitable 12 V DC supply (see [page 6, Power supply options](#)).
- Connect a coaxial cable between the **⌋** connector on the 3160 and the appropriate connector on the antenna.
- Connect the antenna control cable between the **⌋** lead from the interface adaptor and the appropriate connector on the antenna or antenna tuner, if required.

Setting up the transceiver

To set up the transceiver for operation with the 3160:

- Go to the Cfg Auto Tune Mode entry in the Control List.
- Do one of the following:
 - If the transceiver is installed permanently with the 3160, set the Cfg Auto Tune Mode entry to **7750 Ohm**.
 - If the transceiver is installed for jerk-and-run capability, set the Cfg Auto Tune Mode entry to **YATU/7750/77Codan**.
- Switch the transceiver off then on again to activate the change.

The screen should look similar to the following.

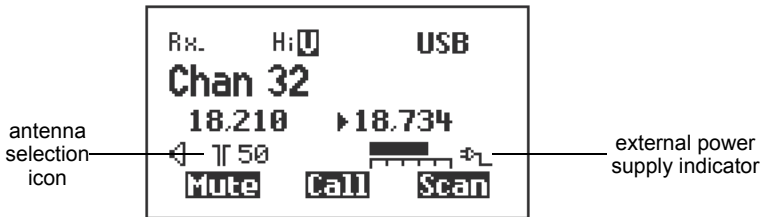

Grounding the 3160

To ground the 3160:

- Attach one end of the earth wire to the earth terminal (⏏) on the connector panel of the 3160.
- Attach the other end of the earth wire to the earth system for the station using the 25 mm long, self-tapping, pan pozi screw provided.

Installing the station

To install the 3160 in a mobile or fixed station:

- Attach the transceiver cradle or the power supply cover to an appropriate mounting surface according to any relevant standards and approvals.

NOTE In a mobile station, you may need to use a mounting setup that absorbs vibration.

- Connect an earth strap to a convenient location on the bodywork or earth system for the building using the 25 mm long, self-tapping, pan pozi screw provided.

NOTE Ensure a good electrical connection is made.

- Connect the antenna to the transceiver (see the fitting instructions provided with the mounting cradle and or equipment).
- Protect any cables that pass through metal panels with rubber grommets.
- Tape the connectors on the antenna, and approximately 25 mm (1 in) of each cable, with two layers of self-amalgamating PIB tape (Rotunda 2501) or EPR tape (3M Scotch™ 23).
- Cover the self-amalgamating tape with two layers of high-quality electrical tape (3M Scotch™ 33+, or similar) to minimise aging of the self-amalgamating tape.
- Test the installed 3160 (with connected transceiver) as described in the Reference Manual provided with your transceiver.

NOTE Troubleshooting for a 3160 and how to install a transceiver are provided in the Reference Manual.

This page has been left blank intentionally.

3 Specifications



These specifications are accurate for a 13.6 V DC supply, with 50 Ω load resistances at 25°C (77°F).

Table 1: Functional specifications

Item	Specification
Frequency range	1.6 to 30 MHz
Power output	125/100 W PEP reducing with frequency to 95 W PEP at 30 MHz ±1 dB CW or single tone: approximately 60% of PEP with average PEP control (average control disabled on handset PTT)
Spurious and harmonic emissions	Better than 60 dB below PEP
Intermodulation (Two-tone test)	125/100 W: 26 dB below each tone 32 dB below PEP
RF input/output impedance	50 Ω nominal
Duty cycle	100%: normal speech over full temperature range 100%: ARQ up to 30°C (86°F) 25%: 16-tone continuous data mode (5 minutes on maximum) at ambient temperature up to 30°C (86°F) 100%: all data modes up to maximum ambient temperature of 45°C (113°F) with Option F
Supply voltage	13.6 V DC nominal, negative earth Normal operating range: 10.8 to 15 V Reverse polarity protected

Table 1: Functional specifications (cont.)

Item	Specification
Overvoltage protection	Shuts down at 16 V \pm 0.5 V DC nominal for duration of overvoltage
Supply current	Output power: 125 W or 100 W Two-tone or CW: 9 to 17 A Average speech: 8 A for battery life calculations Receive: 65 mA
Protection	Safe under all load conditions by limiting reflected power to 10 W PEP and limiting PA transistor collector voltage swing Thermal protection against excessive heatsink temperature
Environment	Ambient temperature: -30 to 60°C (-22 to 140°F) Relative humidity: 95% non-condensing Derate upper ambient temperature by 1°C (33.8°F) per 330 m (361 yd) above sea level. MIL-STD-810F compliance: Method 500.4: Low Pressure (Altitude) Method 506.4: Rain Method 507.4: Humidity Method 508.5: Fungus Method 509.4: Salt Fog Method 510.4: Sand and Dust Method 512.4: Immersion (IP68: immersion for 1 hour at a depth of 1 m (3 ft)) Method 514.5: Vibration Method 516.5: Shock
Cooling	Convection or fan (option F)
Mounting	Free standing Flange mounting (power supply cover) Enclosed mounting (transceiver cradle)

Figure 14: Dimensions

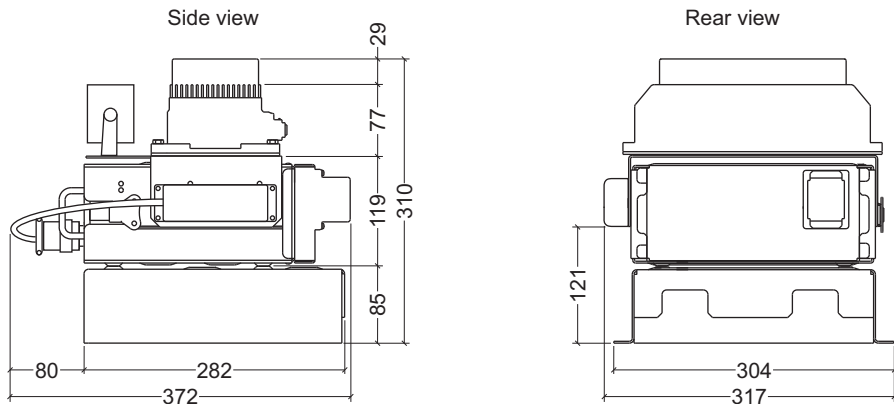

All dimensions in mm

Table 2: Dimensions

Item	Size
Power amplifier	286 mm W × 146 mm D × 77 mm H (11.3 in W × 5.7 in D × 3.0 in H) (includes allowance for connectors)
Power amplifier with fan	286 mm W × 146 mm D × 106 mm H (11.3 in W × 5.7 in D × 4.1 in H)
Transceiver in cradle with interface adaptor and 2110 amplifier adaptor panel	307 mm W × 372 mm D × 112 mm H (12.1 in W × 14.6 in D × 4.4 in H) (includes allowance for connectors)
Power supply cover	304 mm W × 282 mm D × 83 mm H (12.0 in W × 11.1 in D × 3.3 in H)

Table 3: Weights for accessories

Item	Weight
Power amplifier	2.2 kg (4.9 lb)
2110 amplifier adaptor panel	0.3 kg (0.7 lb)
Fan	0.3 kg (0.7 lb)
Power amplifier mounting bracket	0.5 kg (1.1 lb)
Power supply cover, including brackets	1.0 kg (2.2 lb)

4 Accessories

Table 4: Accessories for the 3160 Power Amplifier

Codan part number	Description
15-00147	Power supply cover
15-00148	Power amplifier mounting bracket
08-06900-001	Fan
08-06808-500	Cable, control and power, 0.5 m
08-06808-002	Cable, control and power, 2 m
08-06809-002	Cable, coaxial, 0.7 m
08-06809-001	Cable, coaxial, 2.5 m

This page has been left blank intentionally.

Figure 15: Front view of the 12-way connector on the 3160

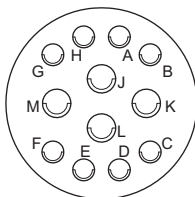

Table 5: Pinouts for the 12-way connector on the 3160

Pin no.	Function	Input/output	Signal level
A	ALC	Output	3.5 V = ALC control
B	Fan (-) switched	Output	0 V
C	DC supply ground (-)	Input	0 V
D	Fan (+)	Output	13.6 V nominal
E	I ² C clock	Input	3.3 V data
F	I ² C data	Input/output	3.3 V data
G	DC supply positive (+)	Input	13.6 V nominal
H	Screen ground	Input	0 V
J	DC supply positive (+)	Input	13.6 V nominal
K	DC supply ground (-)	Input	0 V
L	DC supply ground (-)	Input	0 V
M	DC supply positive (+)	Input	13.6 V nominal

Figure 16: Front view of the 6-way connector on the 2110 amplifier adaptor panel

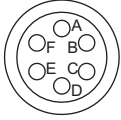

Table 6: Pinouts for the 6-way connector on the 2110 amplifier adaptor panel

Pin no.	Function	Input/output	Signal level
A	Screen ground	Input	0 V
B	DC supply ground (-)	Input	0 V
C	I ² C clock	Input	3.3 V data
D	I ² C data	Input/output	3.3 V data
E	ALC	Output	3.5 V = ALC control
F	DC supply positive (+)	Input	13.6 V nominal

Appendix B—Compliance



This section contains the following topics:

[Introduction \(46\)](#)

[European R&TTE Directive \(46\)](#)

[EMC and safety notices \(47\)](#)

[C-tick approval \(48\)](#)

[IC approval \(52\)](#)

[Register of hazardous substances \(53\)](#)

Introduction

This section describes how to ensure the 3160 Power Amplifier complies with the European EMC Directive 89/336/EEC and the European Low Voltage Directive 73/23/EEC as called up in the European R&TTE Directive 1999/5/EC.



This section also contains the requirements for FCC compliance.

European R&TTE Directive

The 3160 Power Amplifier has been tested and complies with the following standards and requirements (articles of the R&TTE Directive):

- Article 3.1b: ETSI EN301489-1 V1.4.1
- Article 3.1b: ETSI EN301489-15 V1.2.1
- Article 3.1a: EN60950-1

Product marking and labelling

Any equipment supplied by Codan that satisfies these requirements is identified by the **CE0191** , **CE0191**, **CE**  or **CE** markings on the model label of the product.

Declaration of Conformity

The CE Declaration of Conformity for the product is listed on [page 60, *Associated documents*](#). This document can be made available upon request to Codan or a Codan-authorized supplier.

EMC and safety notices

Non-ionising radiation safety

To ensure optimal transceiver performance and to avoid exposure to excessive electromagnetic fields, the antenna system must be installed according to the instructions provided.

WARNING High voltages exist on the antenna during transmission and tuning. Do not touch the antenna during these activities. RF burns may result.

WARNING Install the earthing system or counterpoise as directed to prevent RF burns from any metal part of the transceiver.

WARNING You should not transmit from your transceiver or tune the antenna unless people are beyond the safe working distance of:

- 1.5 m (5 ft) of any part of a mobile antenna
- 2 m (7 ft) of any part of a fixed antenna in a data installation of up to 125 W output

Safe working distance is based on continuous exposure to CW-type transmissions, as set out in the ICNIRP Exposure Guidelines (1998) for occupational exposure. Safe working distance can be reduced with normal voice communication.

EMC

To ensure compliance with the EMC Directive is maintained, you must:

- Use the standard shielded cables supplied from Codan (where applicable).

Electrical safety

To ensure compliance with the European Low Voltage Directive is maintained, you must install the 3160 Power Amplifier in accordance with the instructions in this handbook, and operate the 3160 Power Amplifier in accordance with the instructions in the relevant Getting Started Guide and Reference Manual for your transceiver.

C-tick approval

The 3160 Power Amplifier meets the requirements of the Australian Communications and Media Authority: Radiocommunications (MF and HF equipment—Land Mobile Service) Standards 2003 (AS/NZS 4470).

FCC compliance

FCC Part 90 certification

The 3160 Power Amplifier has been tested and certified to FCC Part 90 (FCC identifier code DYY3160).

FCC Part 15 compliance

Any modifications made to the 3160 Power Amplifier that are not approved by the party responsible for compliance may void your equipment's compliance under Part 15 of the FCC rules.

The 3160 Power Amplifier has been tested and found to comply with the limits for a Class B device, pursuant to Part 15 of the FCC rules. These limits are designed to provide reasonable protection against harmful interference in a residential installation. This equipment generates, uses and can radiate radio frequency energy and, if not installed and used in accordance with the instructions, may cause harmful interference to radio communications. However, there is no guarantee that interference will not occur in a particular installation. If this equipment does cause harmful interference to radio or television reception, which can be determined by switching the equipment off and on, the user is encouraged to try to correct the interference by one or more of the following measures:

- reorient or relocate the receiving antenna
- increase the separation between the equipment and receiver
- connect the equipment into an outlet on a circuit different from that to which the receiver is connected
- consult the dealer or an experienced radio/TV technician for help

Compliance with RF exposure standards

Your Codan HF transceiver system is designed and tested to comply with a number of national and international standards and guidelines (listed below) regarding human exposure to RF electromagnetic energy. This transceiver system complies with the IEEE and ICNIRP exposure limits for occupational/controlled RF exposure environments at duty factors of up to 50% talk (100% listen), and is authorised by the FCC for occupational use.

Your Codan HF transceiver system complies with the following RF energy exposure standards and guidelines:

- United States Federal Communications Commission, Code of Federal Regulations; 47 CFR §§ 2 sub-part J
- American National Standards Institute/Institute of Electrical and Electronic Engineers C95.1–1992
- Institute of Electrical and Electronic Engineers C95.1–1999 Edition

Operating instructions to control RF exposure

To control exposure of yourself and others and ensure compliance with the occupational/controlled environment exposure limits, always adhere to the following procedures:

- Transmit no more than the rated duty factor of 50% of the time, and remain at least 1.5 m from the antenna.
- Do not transmit from the transceiver or tune the antenna unless people outside the vehicle are beyond the safe operating distance of 1.5 m (5 ft) of any part of a mobile antenna.

Mobile antennas

The antenna installation should be in accordance with the supplied installation handbook. Use only Codan's approved supplied antenna.

Approved accessories

The Codan HF transceiver system has been tested and meets the FCC RF exposure guidelines when used with the Codan accessories supplied or designated for this product. Use of other accessories may not ensure compliance with the FCC's RF exposure guidelines, and may violate FCC regulations.

Contact information

For additional information on exposure requirements or other information, see Codan's website (www.codan.com.au).

IC approval

The 3160 Power Amplifier meets the requirements of RSS-131.

The following information is relevant for the 3160 Power Amplifier:

Nominal passband gain	10 dB
Nominal bandwidth	28.4 MHz
Rated mean output power	125 W
Input/output impedance	50 Ω

The manufacturer's rated output power of this equipment is for single carrier operation. For situations when multiple carrier signals are present, the rating would have to be reduced by 3.5 dB, especially where the output signal is re-radiated and can cause interference to adjacent band users. This power reduction is to be by means of input power or gain reduction and not by an attenuator at the output of the device.

Register of hazardous substances

Table 7: 有毒有害物质列表 (Register of hazardous substances)

零件项目 (Component Name)	有毒有害物质或元素 (Hazardous Substances or Elements)					
3160 功率放大器 (3160 Power Amplifier)	铅	汞	镉	六价铬	多溴联苯	多溴二苯醚
3160 主体装配 (3160 Main Assembly)	X	O	O	O	O	O
控制电缆 (Control Cable)	O	O	O	O	O	O
同轴电缆 (Coaxial Cable)	O	O	O	O	O	O
接地线 08-04515-001 (Earth Wire 08-04515-001)	O	O	O	O	O	O
功率放大器 3160 安装手册 (Power Amplifier 3160 Installation Handbook)	O	O	O	O	O	O

- 0 表示该有毒有害物质在该部件的所有均质材料中的含量，均在 SJ/T 11363-2006 标准所规定的限量要求以下。

Indicates that this toxic or hazardous substance, contained in all of the homogeneous materials for this part, is below the limit requirement in SJ/T 11363-2006.

- X 表示该有毒有害物质在该部件的至少一种均质材料中的含量，超出 SJ/T 11363-2006 标准所规定的限量要求。

Indicates that this toxic or hazardous substance, contained in at least one of the homogeneous materials used for this part, is above the limit requirement in SJ/T 11363-2006.

怎么阅读制造日期 - 方法如下：

How to read the date of manufacture:

产品序列号中的第一个数字或字母表示该产品在 2000 年或以后的制造年份。举例来说（数字 0-9）0=2000, 1=2001... 之后接着以字母代表制造年份 A=2010, B=2011...

The first character of the serial number provides the year of manufacture starting from the year 2000, that is, 0=2000, 1=2001...A=2010, B=2011...

产品序列号中的第二个数字或字母表示该产品的制造月份。举例来说（数字 1-9）1=一月份, 2=二月份... 之后接着以字母 A, B, C 代表剩下的制造月份 A=十月份, B=十一月份, C=十二月份。

The second character of the serial number provides the month of manufacture, that is, 1 to 9, A to C; A=10th month, B=11th month and C= 12th month.

Standards and icons

The following standards and icons are used in this handbook:

This typeface **Means...**

Italic a cross-reference or text requiring emphasis

This icon **Means...**



a step within a task

NOTE

the text provided next to this icon may be of interest to you

CAUTION

proceed with caution as your actions may lead to loss of data, privacy or signal quality

WARNING

your actions may cause harm to yourself or the equipment

Acronyms and abbreviations

This term...	Means...
ANSI	American National Standards Institute
CW	continuous wave
DC	direct current
EPR	ethylene propylene rubber
ETSI	European Telecommunications Standards Institute
FCC	Federal Communications Commission
HF	high frequency
ICNIRP	International Commission on Non-Ionizing Radiation Protection
IEEE	Institute of Electrical and Electronic Engineers
PIB	poly isobutylene
R&TTE	radio and telecommunications terminal equipment
RF	radio frequency

Glossary

This term...	Means...
fixed station	A transceiver that is permanently installed and cannot be moved without significant effort. It consists of a transceiver, a transceiver supply, an antenna, control and accessory devices, a 3160, ancillary equipment, and appropriate connecting cables.
mobile station	A station that is usually mounted in a vehicle or is portable and easily transportable. It consists of a transceiver, a power supply, an antenna, control and accessory devices, a 3160, ancillary equipment, and appropriate connecting cables.
basic layout	The layout of the manpack transceiver and 3160 without frames and brackets.
stacked layout	The layout of the manpack transceiver and 3160 with various frames and brackets.

Units

NOTE Imperial dimensions are in United States Customary Units.

Measurement	Unit	Abbreviation
Current	ampere	A
Frequency	hertz	Hz
Impedance	ohm	Ω
Length	metre (inch/feet)	m (in/ft)
Power	watt	W
Power ratio	decibel	dB
Temperature	degrees Celsius (Fahrenheit)	$^{\circ}\text{C}$ ($^{\circ}\text{F}$)
Voltage	volt	V
Weight	gram (pound)	g (lb)

Unit multipliers

NOTE

Units are expressed in accordance with ISO 1000:1992 'SI units and recommendations for the use of their multiples and of certain other units'.

Unit	Name	Multiplier
M	mega	1 000 000
d	deci	0.1
m	milli	0.001

About this issue

This is the second issue of the Power Amplifier 3160 Installation Handbook. Requirements for FCC compliance and IC approval have been added.

Associated documents

This handbook is one of a series of documents associated with the 3160 Power Amplifier. The other documents are:

- Manpack Transceiver 2110M Getting Started Guide (Codan part number 15-04152-EN)
- Manpack Transceiver 2110M Reference Manual (Codan part number 15-04153-EN)
- Manpack Transceiver 2110 series Getting Started Guide (Codan part number 15-04136-EN)
- Manpack Transceiver 2110 series Reference Manual (Codan part number 15-04135-EN)
- Fitting Instruction: 2110 Manpack Transceiver cradle 15-00140 (c/w interface adaptor) (Codan part number 15-00140-001)
- Fitting Instruction: Power supply cover for 2110 Manpack Transceiver 15-00147 (Codan part number 15-00147-001)
- Declaration of Conformity for the 3160 Power Amplifier (Codan part number 19-40330)

Numerics

3160

- components 5
- mounting cradle 20

B

basic layout 17

C

cabling 19

care and safety instructions 13

compliance

- C-tick 48
- EMC and safety notices 47
 - electrical safety 48
 - EMC 48
 - radiation safety 47
- FCC 49
 - approved accessories 51
 - contact information 51
 - mobile antennas 51
 - Part 15 compliance 49
 - Part 90 certification 49
 - RF exposure
 - controlling 50
 - standards 50
- IC 52
- R&TTE Directive 46
 - declaration of conformity 46
 - product marking and labelling 46

connecting equipment 33

connectors 43

C-tick approval 48

E

EMC and safety notices

- compliance
 - electrical safety 48
 - EMC 48
 - radiation safety 47

equipment

- optional 5
- typical 5

F

FCC compliance 49

- approved accessories 51
- contact information 51
- mobile antennas 51
- Part 15 compliance 49
- Part 90 certification 49
- RF exposure
 - controlling 50
 - standards 50

fixed station 20

G

grounding 20, 34

H

hazardous substances 53

I

IC approval 52

installation 15

- 2110 amplifier adaptor panel 24
- 3160 26, 31
- basic layout 17, 21
- cabling 19
- external speaker 26, 31
- fixed station 20
- grounding 20
- mobile station 18
- mounting 20
- power amplifier mounting bracket 27, 31
- power supply 27
- stacked layout 18, 22
- transceiver cradle 24, 27
- voltage regulator 26

L

layout

- basic 17, 21
- stacked 18, 22

M

- mobile station 18
- mounting cradle 20

O

- optional equipment 5
- overview 3

R

R&TTE Directive

- compliance 46
 - declaration of conformity 46
 - product marking and labelling 46

S

safety

- electrical 48
- radiation 47

specifications 37

stacked layout 18

station

- fixed 20
- installing 35
- mobile 18

T

transceiver

- setting up 34

typical equipment 5



CODAN

www.codan.com.au

Head Office

Codan Limited
ABN 77 007 590 605
81 Graves Street
Newton SA 5074
AUSTRALIA
Telephone +61 8 8305 0311
Facsimile +61 8 8305 0411
asiasales@codan.com.au

Codan (UK) Ltd
Unit C4 Endeavour Place
Coxbridge Business Park
Farnham Surrey GU10 5EH
UNITED KINGDOM
Telephone +44 1252 717 272
Facsimile +44 1252 717 337
uksales@codan.com.au

Codan US, Inc.
8430 Kao Circle
Manassas VA 20110
USA
Telephone +1 703 361 2721
Facsimile +1 703 361 3812
ussales@codan.com.au