

## Introduction

TAC has designed a device that allows Andover Continuum controllers to communicate with other controllers across a wireless field bus mesh network. The Andover Continuum Wireless Adapter/Repeater is a single device that can perform two roles — adapter and repeater.

As a **Wireless Adapter**, the device is attached to the service port of a controller and allows the controller to communicate across a wireless mesh network with other controllers. The Wireless Adapter replaces the normal hard-wired network connection between controllers. Power to the Adapter is supplied by the controller, through the service port.

As a **Wireless Repeater**, the device is used to strengthen the mesh network by providing redundant routes to circumvent temporary or permanent obstructions. A robust mesh network is able to self heal by dynamically creating optimal routes. A Repeater may be needed when there are long distances between wireless-enabled controllers, or to compensate for obstructions, such as pipes or walls that can attenuate or weaken the wireless signal between controllers.

When the device is used as a wireless repeater, it is not connected to a controller, can be installed almost anywhere, and only requires a power source to function.

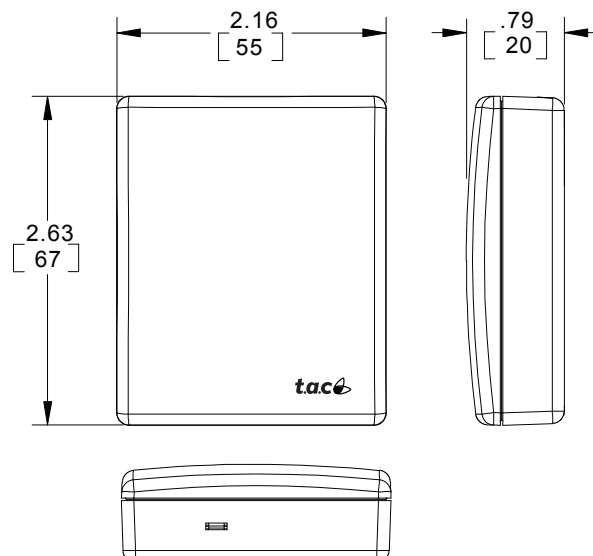

## Wireless Adapter/Repeater Installation Steps

### To install on a wall:

- 1) Locate an appropriate area to install the unit.
- 2) Locate the cover latch on the bottom of the unit and use a small screwdriver to squeeze the latch and remove the cover from the unit.

*Note: The PC board is exposed. Handle with care to prevent damage to the components by electrostatic discharge.*

- 3) Place the unit in position. Mark the location of the mounting hole.
- 4) Use a drill to create a small pilot hole for a #6 (3.5mm) mounting screw, or for the wall anchor, if necessary. (Screw and wall anchor are provided.)
- 5) Insert the #6 mounting screw through the unit and into the wall, being careful not to over tighten and damage the electronics.
- 6) Snap the cover back in place.

*Note: The wireless adapter may be positioned so the cable comes out the top or bottom of the device. The cover can be installed in either direction.*

### To hang vertically from a ceiling or object:

- 1) Make sure the unit is closed.
- 2) Insert a tywrap, wire, or thin cord through the mounting recess located in the top center of the unit.

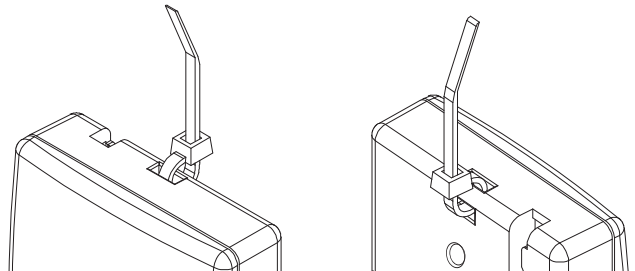

- 3) Secure the unit, fastening the tywrap, wire, or thin cord over, through, or around the mounting object. (i.e., eyehook, exposed screw, pipe, ceiling support, etc.)
- 4) Make sure the unit is secure.

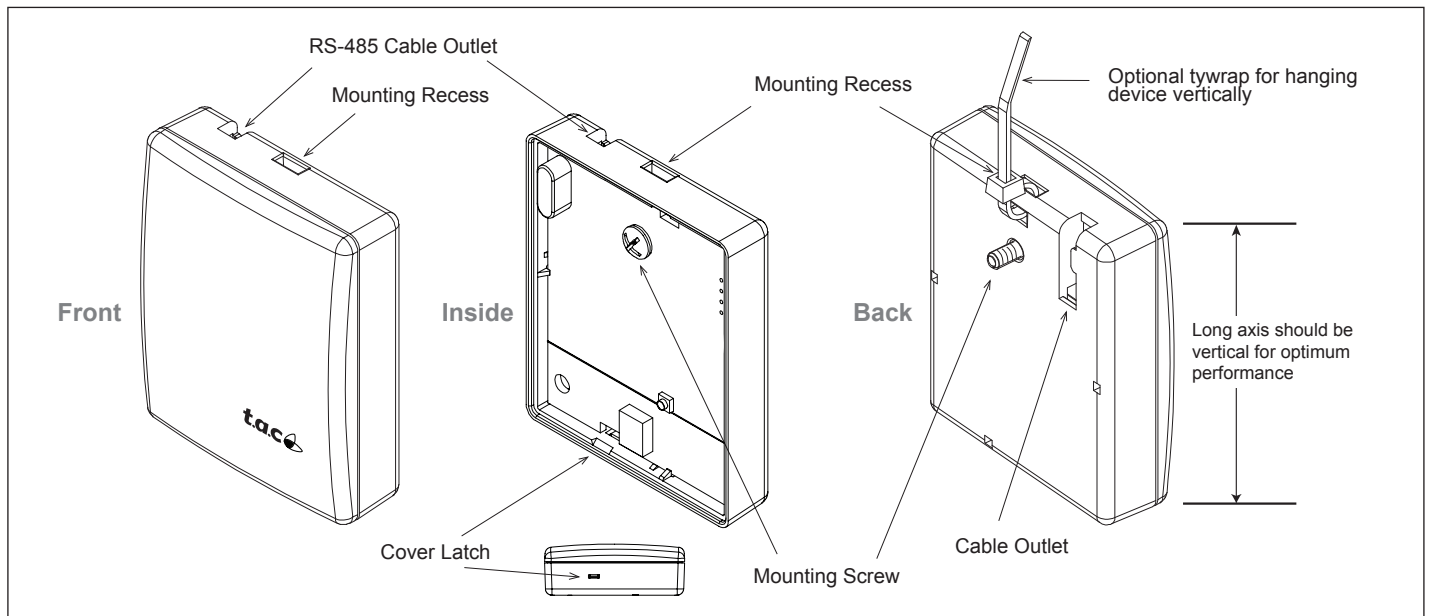

## Installation Notes

- 1) Install the Adapter/Repeater with the long axis vertical for optimum performance.
- 2) Install away from metal or water-filled objects. These objects block or diminish the signal.
- 3) Install at a horizontal plane height where there are as few objects as possible. For example, in an office with cubicles, install the units two feet or so above the average cubicle wall height. This placement allows the adapters/repeaters to transmit across a horizontal plane that does not contain a lot of objects that can potentially block or diminish the signal.
- 4) Once installed, select a channel that is not normally used by other wireless applications. The default channel is 3, but you can reset the channel using the Andover Continuum Wireless Maintenance Tool. (Note: The frequencies of the TAC Wireless Adapter (802.15.4) channels do not line-up with Wi-Fi (802.11) channels. For example, TAC channel 3 is between Wi-Fi channels 1 and 2.)

## Connecting the Adapter to a Controller

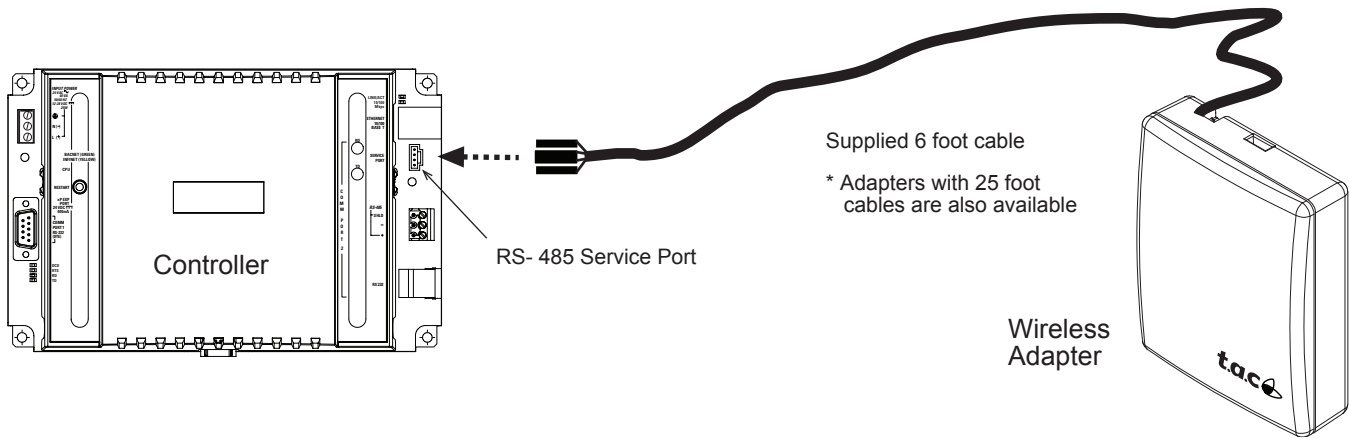

- 1) Connect the Wireless Adapter to a controller's service port using the RS-485 4-pin connector.
- 2) The controller will automatically recognize ("learn") the other wireless devices on the wireless field bus (mesh network).

*Notes: On the bCX fieldbus, you must set the default mode of COMM2 to "Wireless."  
A learn will discover wireless i2/b3 controllers that are properly configured*

## Controllers with Hidden Service Port Connections

On most Andover Continuum controllers, the service port connection is located outside the cover and labelled appropriately. However, there are a few controllers where the service port connections are only accessible by removing the controller covers.

The following illustration lists the controllers with internal service ports and identifies their approximate location on the controller circuit boards. Some of the controllers have service port connectors, so the correct pin orientation is guaranteed. For controllers that only have the four individual service port pins, the following illustration shows the correct orientation of the Wireless Adapter cable's connector, using the location of the connector's raised tab.

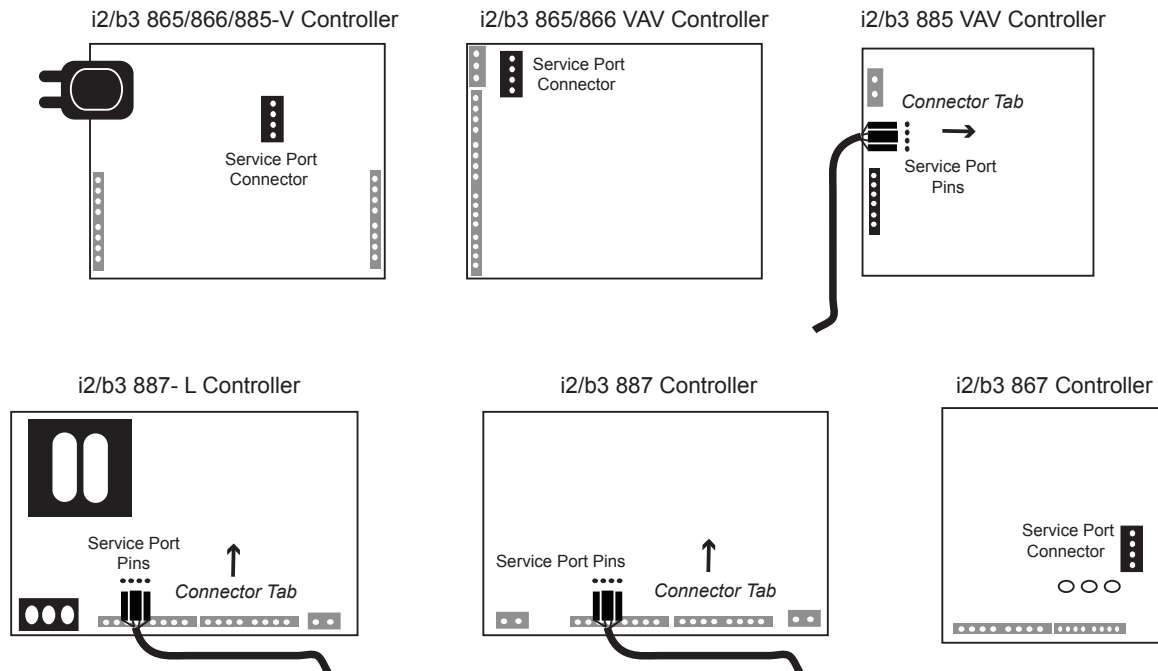

Controller Circuit Board Locations of Service Port Connector or Pins

## Connecting the Repeater to a Power Supply

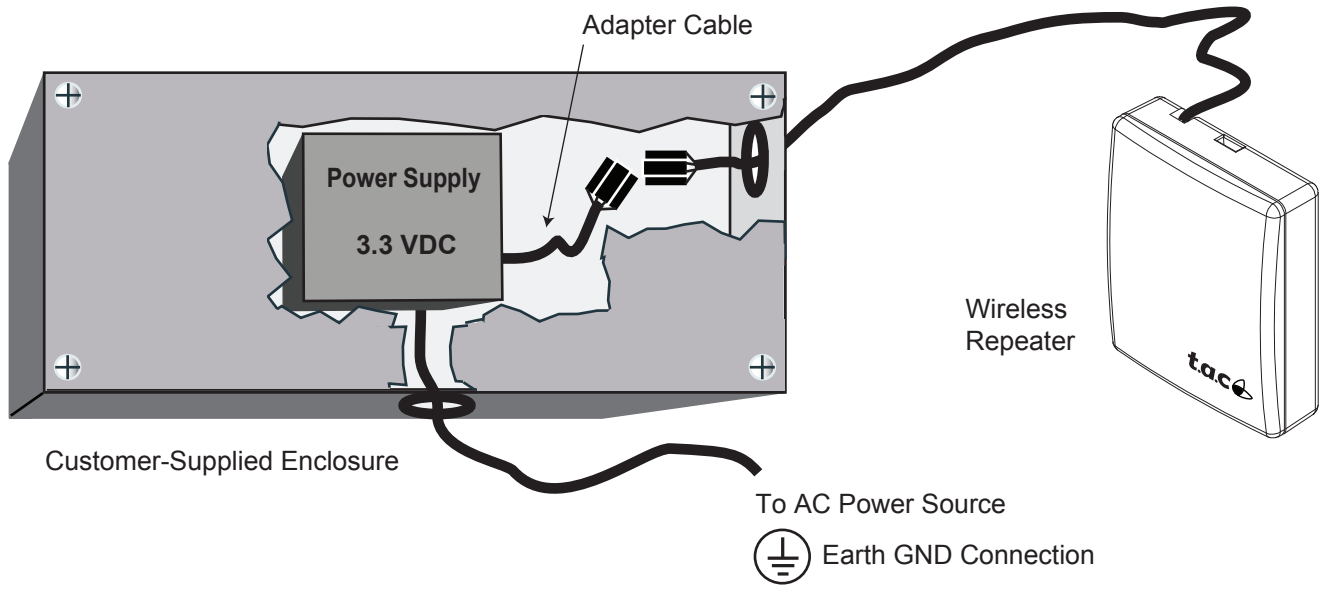

- 1) Connect the attached Wireless Adapter/Repeater cable to the power supply adapter cable.
- 2) Connect the power supply adapter cable to the power supply.

*Note: The power supply is not part of the Wireless Adapter/Repeater and is sold separately.*

## Specifications

### Environment

#### Standard Operating Temperatures

-40 to 185 degrees F (-40 to 85 degrees C)

#### Storage Temperature

-40 to 185 degrees F (-40 to 85 degrees C)

#### Humidity (non-condensing)

0 to 95%

### Power Requirements

#### Wireless Adapter

Power = 3.3 volts +/- 5% @ 75 mA

Supplied by the controller via the service port connection.

#### Wireless Repeater

Power = 3.3 VDC to 5 VDC +/- 5% @ 75 mA

Supplied by a 3.3 VDC to 5 VDC power supply.

### Wireless Communications

#### Frequency Range

16 Software selectable channels

2405 MHz to 2480 MHz, 5 MHz channel spacing

#### Modulation Type

O-QPSK Direct Sequence Spread Spectrum (DSSS) per IEEE 802.15.4 standard

#### Output Power

0 to +10dBm typical

Software selectable

#### Speed

250 Kbps

#### Transmission Range

200 meters (650 feet) Outdoors Line of Sight

10 to 60 meters (30 to 200 feet) indoor range

Distances vary based on environmental conditions

#### Antenna

Internal

#### Connection

RS-485 Speed: 38.4K to 50K baud

RS-485 Connector: Four pins (two pins data, one power, one ground)

# Regulatory Notices

## Federal Communications Commission

FCC Rules and Regulations CFR 47, Part 15, Class C

This device complies with part 15 of the FCC Rules. Operation is subject to the following two conditions: (1) This device may not cause harmful interference, and (2) this device must accept any interference received, including interference that may cause undesired operation.

*Caution: The user that changes or makes modifications not expressly approved by Tour Andover Controls, Inc. for compliance could void the user's authority to operate the equipment.*

FCC ID: DVE-WIRELESS

This product meets FCC Radiation Exposure requirements. Make sure to install and operate the device in such a way as to maintain a minimum of 20cm separation distance between the device and a person's body.

## Industry Canada Radio Equipment

IC RSS 210 Industry Canada

This digital apparatus does not exceed the wireless requirements for Industry Canada IC RSS-210 and is listed on the Industry Canada Radio Equipment List.

IC: 1026A-WIRE

## CE - Compliance to European Union (EU)

89/336/EEC - EMC Directive

EN300328/EN30149, EMC - Radio Spectrum Matters

This equipment complies with the rules of the Official Journal of the European Communities specified in the EMC directive 89/336/EEC governing the Self Declaration of the CE Marking for the European Union.



## N1831 C-Tick (Australian Communications Authority (ACA))

AS/NZS 3548

This equipment carries the C-Tick label and complies with EMC and radio communications regulations of the Australian Communications Authority (ACA), governing the Australian and New Zealand (AS/NZS) communities.



## WEEE - Directive of the European Union (EU)

This equipment and its packaging carry the waste of electrical and electronic equipment (WEEE) label, in compliance with European Union (EU) Directive 2002/96/EC, governing the disposal and recycling of electrical and electronic equipment in the European community.

TAC / Tour Andover Controls, Inc.  
One High Street  
North Andover, MA 01845  
(978) 470-0555  
Fax: (978) 975-9782  
<http://www.tac.com>

