

ELECTROMAGNETIC DISTURBANCE TEST REPORT

Doc. No. 20010305R/Project No. 607

TEST STANDARDS: USA CFR 47 PART 15 REQUIREMENTS

RFID TAG PAD READER (SERIAL) MODEL 741407
FCC ID: DO4PRO7100

DIAMOND CHECKPOINT DEVELOPMENT GROUP
THOROFARE, NEW JERSEY

TEST DATE: 10/20/00 TO 12/6/00
ISSUE: January 19, 2001

Prepared by: *Paul Banker*
Paul Banker
Technical Staff Engineer

Approved: *Wallace E. Amos*
Wallace E. Amos
Group Manager, PCTC/ICC

The results described in this report relate only to the item(s) tested.
This document shall not be reproduced except in full without written permission of Unisys - PCTC.



PREFACE

This report documents product testing conducted to verify compliance of the specified EUT with applicable standards and requirements as identified herein. EUT, test instrument configurations, test procedures and recorded data are generally described in this report. The reader is referred to the applicable test standards for detailed procedures. The following table summarizes the test results obtained during this evaluation.

SUMMARY

The Diamond Checkpoint Development Group, Inc., RFID Tag Pad Reader (Serial) Model 741407 was tested to the standards listed below, and found to have the following characteristics:

| TEST | STANDARD | REQUIREMENT | RESULT |
|---|--------------------|---|------------------|
| Radiated Emissions - Intentional Radiator | FCC 15.225, 15.209 | 13 MHz - 1 GHz | Below Limit |
| Radiated Emissions Digital Device | FCC Class A | General Requirements 30 MHz - 1 GHz | Below Limit |
| Conducted Emissions | FCC 15.207 | General Requirements 450 kHz to 30 MHz | Below Limit |
| Frequency Stability | FCC 15.225 | ±0.01% | Within Tolerance |

TABLE OF CONTENTS

| | | |
|---------|---|----|
| 1.0 | Client Information..... | 5 |
| 1.1 | Requested Service..... | 5 |
| 1.2 | Purpose of Test(s)..... | 5 |
| 2.0 | Description of the Equipment Under Test (EUT)..... | 6 |
| 2.1 | General Description and Operational Overview | 6 |
| 2.2 | Equipment Sample | 7 |
| 2.2.1 | Identification..... | 7 |
| 2.2.2 | Condition of Received Sample..... | 7 |
| 3.0 | Applicable Requirements, Methods and Procedures | 7 |
| 3.1 | Applicable Requirements..... | 7 |
| 3.1.1 | USA | 7 |
| 3.2 | Basic Test Methods and Procedures | 8 |
| 4.0 | Deviations or Exclusions from the Requirements and Standards..... | 8 |
| 5.0 | Operation of the EUT during Testing | 8 |
| 5.1 | Test Environment..... | 8 |
| 5.1.1 | Climatic Environment | 8 |
| 5.1.2 | Electrical Power | 8 |
| 5.1.2.1 | Radio Disturbance Measurements..... | 8 |
| 5.2 | Grounding | 9 |
| 5.3 | Operating Mode | 9 |
| 5.3.1 | Rationale for the Chosen Mode of Operation | 9 |
| 5.4 | Test Configuration | 10 |
| 5.4.1 | Test Configuration Block Diagram | 10 |
| 5.4.2 | EUT Details | 11 |
| 5.4.3 | Rationale for the Chosen Test Configuration..... | 11 |
| 5.5 | EUT Classification..... | 11 |
| 5.6 | EUT Modifications | 11 |
| 6.0 | Summary of Tests Performed, Procedures and Test Results | 12 |
| 6.1 | Radiated Emission Test..... | 12 |
| 6.1.1 | Radiated Emission Test Procedure | 12 |
| 6.1.1.1 | Test Facilities..... | 12 |
| 6.1.1.2 | Emissions Test Procedure | 12 |
| 6.1.2 | Radiated Emissions Test Results – 30 MHz to 5 GHz (10/20/2000)..... | 15 |
| 6.1.3 | Radiated Emissions Test Equipment..... | 17 |
| 6.2 | Conducted Emission Test | 18 |
| 6.2.1 | Conducted Emission Test Procedure | 18 |
| 6.2.2 | Conducted Emissions Test Results 150kHz – 30 MHz (10/30/2000)..... | 19 |
| 6.2.3 | Conducted Emissions Test Equipment..... | 20 |
| 6.3 | Frequency Stability Test (11/9/00) | 20 |
| 6.3.1 | Frequency Stability Test Procedure | 20 |
| 6.3.2 | Frequency Stability Test Results..... | 22 |
| 6.3.3 | Frequency Stability Test Equipment..... | 23 |

INDEX OF PHOTOGRAPHS

Photo 1 – RFID Tag Pad Reader (Serial) Model 741407 6
Photo 2 – Radiated Emissions Test Setup – Front View 14
Photo 3 – Radiated Emissions Test Setup – Rear View 14
Photo 4 – Radiated Emissions Test Setup – Rear View 17
Photo 5 – Conducted Emissions Test Setup – Front View 19

INDEX OF FIGURES

Figure 1 – Block Diagram, EUT Configuration for EMI Testing..... 10

INDEX OF TABLES

Table 1 – List of Cable Interconnections 10
Table 2 – Equipment Under Test 11
Table 3 – Support Equipment 11
Table 4 – Radiated Emissions Data – 1.707 to 30 MHz 15
Table 5 – Radiated Emissions Data – 30MHz to 1 GHz -Transmitter Harmonics..... 15
Table 6 – Radiated Emissions Data 30 MHz to 1 GHz – Digital Circuitry 16
Table 7 – Radiated Disturbance Test Equipment..... 17
Table 8 – Conducted Emissions, RFID Tag Pad Reader (Serial) Model 741407, Neutral line (120 VAC/60 Hz) 19
Table 9 – Conducted Emissions, RFID Tag Pad Reader (Serial) Model 741407, Phase Line (120 Vac/60 Hz) 20
Table 10 – Temperature Stability Table..... 22
Table 11 – Frequency Stability Test Equipment..... 23

1.0 Client Information

Client Name: Diamond Checkpoint Development Group
550 Grove Road
Thorofare, NJ 08086

Coordinator: Anthony Mignogna

PCTC Personnel: Paul Banker
Ray Rashied

1.1 Requested Service

- Measurement of radio disturbance characteristics of sample product to FCC Part 15.225 for intentional radiators operating at 13.553 - 13.567 MHz.
- Measurement of radio disturbance characteristics of sample product to FCC Part 15, Class A for unintentional radiators.
- Measurement of frequency stability characteristics of sample product to FCC Part 15.225 for intentional radiators operating at 13.553 - 13.567 MHz.

1.2 Purpose of Test(s)

The purpose of testing was to verify compliance of the sample EUT to regulatory and/or qualification requirements adhered to by the client for product sale, distribution and use.

2.0 Description of the Equipment Under Test (EUT)



Photo 1 – RFID Tag Pad Reader (Serial) Model 741407

2.1 General Description and Operational Overview

The RFID Tag Pad Reader (Serial) Model 741407 is also identified as a TPRO7100. The TPRO7100 function is to read RFID tags, which contain product information. The TPRO can read RFID tag data within twelve inches above the reader's surface.

The TPRO7100 consists of a TR4090 transceiver board and an antenna. The TR4090 continuously drives the antenna at a carrier frequency of 13.56MHz.

The antenna field powers the RFID tag. Once the tag has power, it sends out information by tuning and de-tuning its resonant circuit. When tuned, the tag loads the reader antenna, which causes small amplitude perturbations of the reader field. The transceiver receives this signal using AM detection, applies gain, and filters the signal.

The TR4090 converts tag data to ASCII and transmits this data over its serial port to a host PC.

2.2 Equipment Sample

2.2.1 Identification

| | |
|-------------------|------------------------------------|
| Description: | RFID Tag Pad Reader Model # 741407 |
| Serial Number: | Prototype |
| Received by PCTC: | October 20, 2000 |
| Sample Type: | Pre-production |

2.2.2 Condition of Received Sample

The RFID Tag Pad Reader (Serial) Model 741407 was conducted to verify test subject identity and condition and to ensure suitability for testing. No evidence of physical damages was noticed. The test item condition was deemed acceptable for the performance of the requested test services.

3.0 Applicable Requirements, Methods and Procedures

3.1 Applicable Requirements

The results of the measurement of the radio disturbance characteristics of the EUT described herein may be applied, and where appropriate provide a presumption of compliance to one or more of the following requirements or to other requirement at the discretion of the client, regulatory agencies, or other entities.

3.1.1 USA

- 47 CFR, part 15, Subpart B, "Unintentional Radiators, General Rules and Regulations".
- 47 CFR, part 15, Subpart C, "Intentional Radiators".

3.2 Basic Test Methods and Procedures

The applicable regulatory product family or generic standards require that radio disturbance/interference tests be performed in accordance with the following:

- C63.4, 1992 “Methods of Measurement of Radio-Noise Emissions from Low-Voltage Electrical and Electronic Equipment in the Range of 9 kHz to 40 GHz.”

4.0 Deviations or Exclusions from the Requirements and Standards

There were no deviations or exclusions from the requirements.

5.0 Operation of the EUT during Testing

5.1 Test Environment

5.1.1 Climatic Environment

The following were the ambient conditions in the laboratory during testing:

| | |
|-------------------|--------------|
| Temperature: | 22° C ± 5° C |
| Relative Humidity | 50% ± 10% RH |

5.1.2 Electrical Power

The EUT was operated at electrical power voltage and frequencies sufficient to ensure that the measured results were representative of operation of the EUT in the power environments in which it would be installed, as specified by the client.

5.1.2.1 Radio Disturbance Measurements

Radiated and conducted disturbance measurements were performed with the RFID Tag Pad Reader (Serial) Model 741407 operating at 120 Vac/60Hz.

5.2 Grounding

Earth grounding of the EUT was accomplished through the AC mains power cord of the test item and the RS232 I/O cable shield.

5.3 Operating Mode

During testing, the Tag Pad was continuously transmitting and monitoring for the presence of an ID tag. A tag was placed in the vicinity of the Tag Pad such that it would continuously detect and transmit data.

5.3.1 Rationale for the Chosen Mode of Operation

The presence of an ID tag, constantly being read and verified, exhibits the full functionality of the RFID Tag Pad Reader (Serial) Model 741407 as would exist in a customer installation.

5.4 Test Configuration

5.4.1 Test Configuration Block Diagram

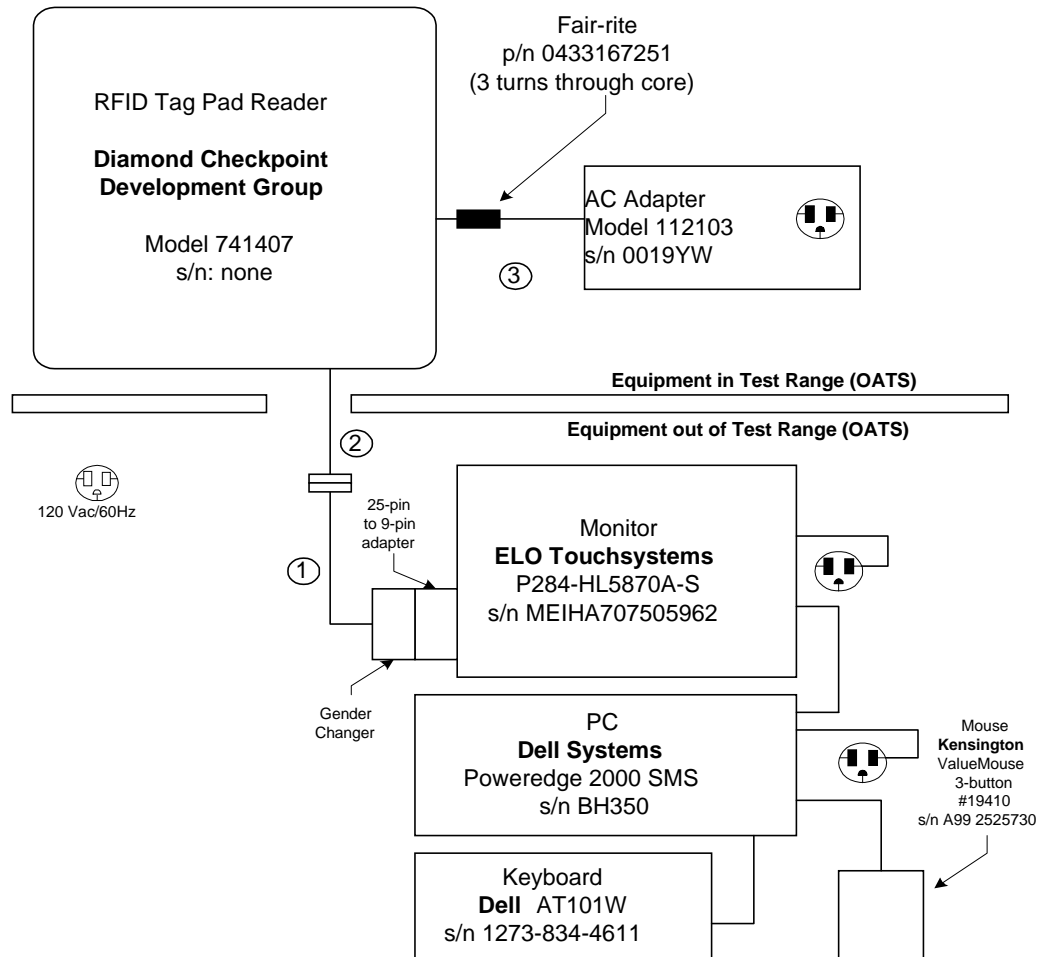

Figure 1 – Block Diagram, EUT Configuration for EMI Testing

Table 1 – List of Cable Interconnections

| # | Description | Manufacturer | Part Number | Length | Shielding |
|---|-----------------|--------------------|-------------|--------|-----------|
| 1 | RS232 Cable | Belken | F2L088-06 | 6' | Foil |
| 2 | RS232 Extension | Unisys | 2820468-38 | 25' | Braid |
| 3 | DC Power cable | Diamond Checkpoint | Unknown | 6' | None |

5.4.2 EUT Details

Table 2 – Equipment Under Test

| Item Description | Manufacturer | Model Number | Serial Number |
|-------------------------|---------------------|---------------------|----------------------|
| RFID Tag Pad Reader | Diamond Checkpoint | 741407 | - |
| AC Adapter | Diamond Checkpoint | 112103 | 0019YW |

Table 3 – Support Equipment

| Item Description | Manufacturer | Model Number | Serial Number |
|-------------------------|---------------------|---------------------|----------------------|
| Personal Computer | Dell Systems | Poweredge 2000 SMS | BH350 |
| Monitor | ELO Touchsystems | P284-HL5870A-S | MEIHA707505962 |
| Keyboard | Dell Systems | AT101W | 1273-834-4611 |
| Mouse | Kensington | ValueMouse 3-button | A99 2525730 |
| Gender Changer | Belken | F4A251 | - |
| 25-pin to 9-pin adapter | Roline | - | - |

5.4.3 Rationale for the Chosen Test Configuration

The configuration of the RFID Tag Pad Reader (Serial) Model 741407 was chosen to demonstrate the emission characteristics of the RS232 interface. The AC Adapter used is the model sold with the RFID Tag Pad Reader (Serial) Model 741407.

5.5 EUT Classification

The test item has been defined an intentional radiator operating in the band 13.553 MHz to 13.567 MHz. For this reason the emissions testing was carried out in accordance with the requirements of FCC 15.225. In addition, the test item contains digital control and signal processing circuitry. Signals identified as related to the digital circuitry were compared to the FCC Class A limits for digital devices.

5.6 EUT Modifications

A block of ferrite was attached to the DC power cable, from the AC Adapter. The ferrite block has a part number of 0433167251 and is manufactured by Fair-Rite. The DC wire, from the AC Adapter, was passed through the core of the block three times and was attached four inches from the Tag Pad DC connector.

6.0 Summary of Tests Performed, Procedures and Test Results

6.1 Radiated Emission Test

6.1.1 Radiated Emission Test Procedure

6.1.1.1 Test Facilities

The test site is an all-weather, open-field measurement facility defined by an elliptical area of 3258 square meters, which is free of reflective metallic objects and extraneous electromagnetic signals. A non-metallic A-Frame enclosure covers 172 square meters of the ellipse. This enclosure contains a ground level 5-meter diameter turntable, capable of rotating equipment through a complete 360 degrees, and a 3-meter and 10 meter test range with remotely controlled antennae masts. The floor of the A-Frame and surface of the turntable are covered with a flat metal continuous ground plane. The ground plane extends outside the A-Frame to a distance of 35.6 meters from the center of the turntable. The width of the extension is 2.4 meters.

The ground plane is partially covered with protective insulating material. A cellar located beneath the ground level of the A-Frame structure houses personnel and instrumentation for remote control of the antennae, the turntable, and other equipment above ground level. Reference the attached drawing for a view of the test facility. The test site complies with the Attenuation Measurements specified in ANSI C63.4 - 1992, and is registered with FCC, and accredited by AALA, VCCI, BSMI, and NEMKO.

For electric field radiated emissions, the EUT and support peripherals or devices required to facilitate EUT operation were positioned either directly on the turntable surface or on a wooden table 80 cm. in height, depending on the size of the sample. Hardware not needed in the test field such as remote terminals or non standard exercisers, were placed in the basement below the turntable

6.1.1.2 Emissions Test Procedure

9kHz to 30 MHz

Testing below 30 MHz was performed with the test item configured on the test site as above. An H-field measuring antenna was placed at a distance of 30 meters from the test item. The height of the antenna is 1 meter above the ground plane. The test item was rotated 360° in order to obtain a maximum indication on the measuring receiver. This was repeated for each of the three polarization of the antenna. In some cases the measuring antenna was taken off the ground plane and placed in the adjacent grass area. The position of the antenna relative to the ground plane was noted in the reported data.

30 MHz to 1000 MHz

Initial measurements, for the purpose of identifying suspect emissions from the equipment under test, were performed by dividing the test frequency range into the following twenty bands:

| | | | | | |
|----|---------------|-----|---------------|-----|----------------|
| 1) | 30 - 40 MHz | 8) | 108 - 148 MHz | 15) | 570 - 670 MHz |
| 2) | 40 - 50 MHz | 9) | 148 - 165 MHz | 16) | 670 - 770 MHz |
| 3) | 50 - 88 MHz | 10) | 165 - 200 MHz | 17) | 770 - 855 MHz |
| 4) | 88 - 93 MHz | 11) | 200 - 300 MHz | 18) | 855 - 875 MHz |
| 5) | 93 - 98 MHz | 12) | 300 - 450 MHz | 19) | 875 - 892 MHz |
| 6) | 98 - 103 MHz | 13) | 450 - 470 MHz | 20) | 892 - 1000 MHz |
| 7) | 103 - 108 MHz | 14) | 470 - 570 MHz | | |

Each of these bands was monitored on a spectrum analyzer display while the turntable was initially positioned at the reference 0-degree point. A mast mounted broadband antenna was located at a distance of 10 meters from the periphery of the EUT(s). The antenna was set to 1-meter height, for the vertical polarity and 2.5 meters height, for horizontal polarity for these suspect emission scans. All emissions with amplitudes 8 dB or less below the appropriate regulatory limit were identified and saved for later source identification and investigation. This initial suspect identification procedure was repeated for turntable positions of 90, 180 and 270 degrees.

The source of questionable emissions was verified by powering off the EUT(s). Those emissions remaining were removed from the suspect list. Valid suspect emissions were then maximized through cable manipulation. The highest six signals or all within 4 dB of the limit, identified during this initial investigation, were then maximized by rotating the turntable through a complete 360 degrees of azimuth and raising the antenna from 1 to 4 meters of elevation. When the EUT(s) azimuth, antenna height and polarization that produced the maximum indication were found, the emission amplitude and frequency were re-measured to obtain maximum peak and quasi-peak field strength. The frequencies and amplitudes of RFI emissions are recorded in this report in units derived as follows:

Field Strength (dBuV/m) = Meter reading (dBuV)+ Antenna factor (dB/m)+ Cable Loss (dB)



Photo 2 – Radiated Emissions Test Setup – Front View



Photo 3 – Radiated Emissions Test Setup – Rear View

6.1.2 Radiated Emissions Test Results – 30 MHz to 5 GHz (10/20/2000)

Transmitter related signals 13 - 30 MHz - FCC 15.225, 15.209

The table below shows the detected field strengths as measured from the test sample(s) over the frequency range from 13 MHz to 30 MHz. The emissions were measured at a distance of 10 meters and compared to the maximum permissible FCC limit at extrapolated (using limit - $20\log(10/30) = \text{limit} + 9.5 \text{ dB}$) to 10 meters for signals and harmonics of an intentional radiator. Notes: Signals were measured with antenna on ground plane. Preliminary testing showed the field strength decreased more than 20 dB/decade. Thus the 20-dB/decade correction used during final testing was judged to be acceptable.

Table 4 – Radiated Emissions Data – 1.707 to 30 MHz

| Freq [MHz] | Height, Pol [cm H/V] | Angle [Deg] | Quasi Peak Voltage [dBuV] | Corr' Factor [dB/m] | Field Strength [dBuV/m] | FCC Class B Limit @ 10m [dBuV/m] | Delta Limit [dB] | Result |
|------------|----------------------|-------------|---------------------------|----------------------|-------------------------|----------------------------------|------------------|--------------------|
| 13.56 | 100 V | 338 | 59.2 (PK) | -1.2 | 58.0 | 89.5 | -30.3 | Below 15.225 limit |
| 27.12 | 100 V | 338 | 18.5 (QP) | 1.7 | 20.2 | 39.0 | -18.8 | Below 15.209 limit |

- Overall Result: All measured transmitter related radiated emissions below 30 MHz from the RFID Tag Pad Reader (Serial) Model 741407 are below the FCC limits by a margin of 18.8 dB.

Transmitter related signals 30 to 1000 MHz - FCC 15.209

Transmitter related radiated emission signals were measured at a distance of 3 meters from the test sample(s) over the frequency range from 30 MHz to 1000 MHz. The levels were then compared to the maximum permissible FCC limit at 3 meters for spurious signals and harmonics of an intentional radiator. Transmitter harmonics from the RFID Tag Pad Reader (Serial) Model 741407 are below the FCC 15.209 general radiation limits by a margin of 13 dB.

Table 5 – Radiated Emissions Data – 30MHz to 1 GHz -Transmitter Harmonics

| Freq [MHz] | Height, Pol [cm H/V] | Angle [Deg] | Quasi Peak Voltage [dBuV] | Corr' Factor [dB/m] | Field Strength [dBuV/m] | FCC Class B Limit @ 3m [dBuV/m] | Delta Limit [dB] | Result |
|------------|----------------------|-------------|---------------------------|----------------------|-------------------------|---------------------------------|------------------|-------------|
| 67.814 | 101, V | 330 | 13.6 | 11.8 | 25.4 | 40.0 | -14.6 | Below limit |
| 81.632 | 136, V | 006 | 15.2 | 10.9 | 26.1 | 40.0 | -13.9 | Below limit |
| 94.920 | 100, V | 343 | 18.7 | 11.8 | 30.5 | 43.5 | -13.0 | Below limit |
| 108.485 | 102, V | 357 | 11.9 | 12.9 | 24.8 | 43.5 | -18.7 | Below limit |
| 122.033 | 102, V | 356 | 10.5 | 13.0 | 23.5 | 43.5 | -20.0 | Below limit |
| 149.163 | 103, V | 332 | 12.6 | 11.7 | 24.3 | 43.5 | -19.2 | Below limit |

Digital circuitry related signals 30 to 1000 MHz - FCC 15.109b

The table below shows the detected field strengths as measured from the test sample(s) over the frequency range from 30 MHz to 1000 MHz, at a distance of 10 meters compared to the maximum permissible FCC Class A limit.

Table 6 – Radiated Emissions Data 30 MHz to 1 GHz – Digital Circuitry

| Freq [MHz] | Height, Pol [cm H/V] | Angle [Deg] | Quasi Peak Voltage [dBuV] | Corr' Factor [dB/m] | Field Strength [dBuV/m] | FCC Class A Limit @ 10m [dBuV/m] | Delta Limit [dB] | Result |
|------------|----------------------|-------------|---------------------------|---------------------|-------------------------|----------------------------------|------------------|-------------|
| 42.000 | 100, V | 000 | 6.3 | 10.2 | 16.5 | 39.08 | -22.6 | Below limit |
| 80.013 | 342, H | 095 | 11.3 | 9.7 | 21.0 | 39.08 | -18.1 | Below limit |
| 267.382 | 337, H | 146 | 9.7 | 16.1 | 25.8 | 43.52 | -17.7 | Below limit |
| 275.759 | 396, H | 350 | 10.4 | 16.3 | 26.7 | 43.52 | -16.8 | Below limit |
| 426.108 | 101, V | 348 | 5.8 | 19.1 | 24.9 | 43.52 | -18.6 | Below limit |
| 459.580 | 255, H | 326 | 8.8 | 19.8 | 28.6 | 43.52 | -14.9 | Below limit |

- Overall Results: The RFID Tag Pad Reader (Serial) Model 741407 complied with the requirements of 47 CFR Part 15B for Class A equipment by a margin of at least 14.9 dB.

Fundamental Spectral Plot

This picture is the fundamental frequency of 13.56 MHz displayed on a spectrum analyzer using a resolution bandwidth of 1 kHz.

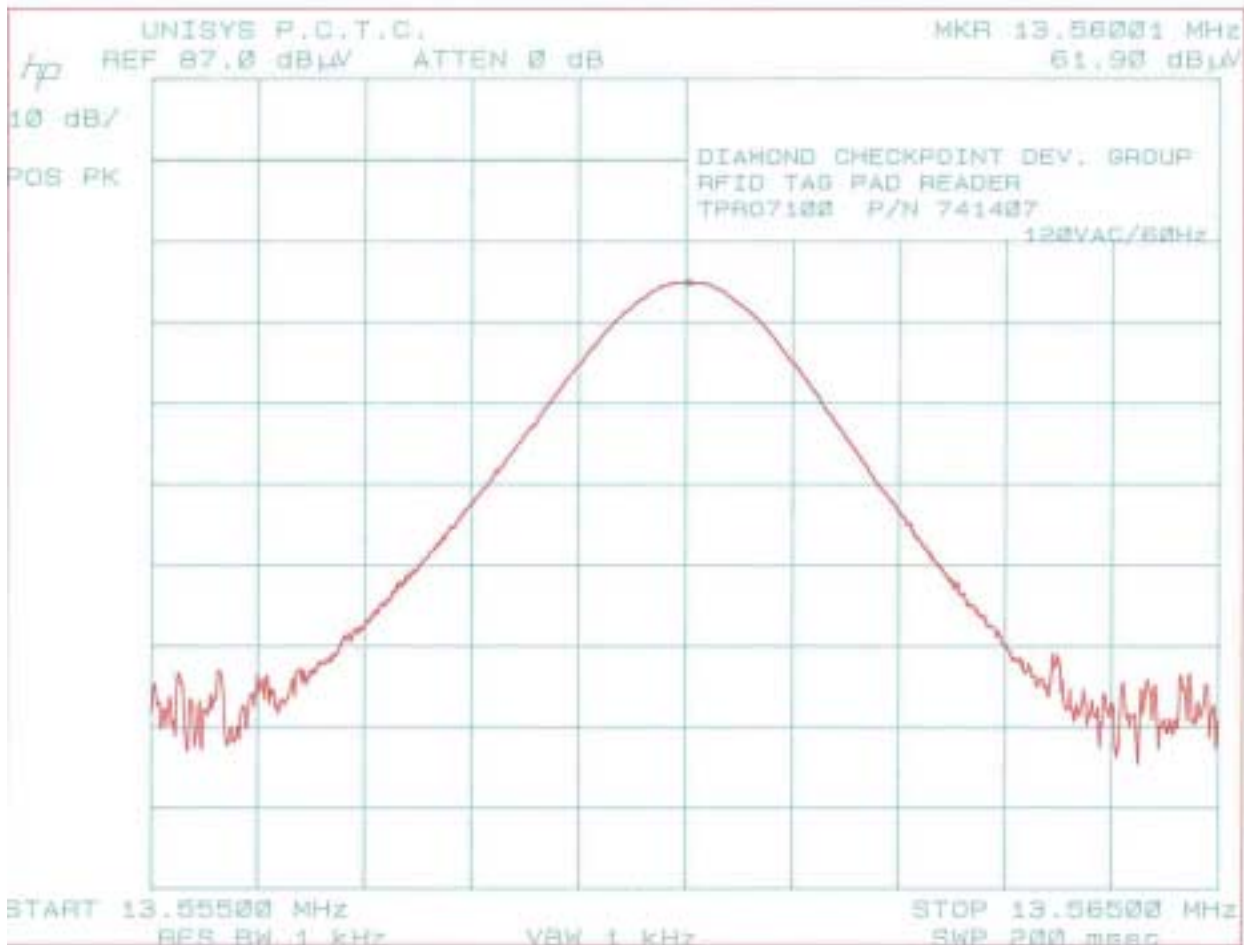

Photo 4 – Radiated Emissions Test Setup – Rear View

6.1.3 Radiated Emissions Test Equipment

Table 7 – Radiated Disturbance Test Equipment

| <u>Equipment</u> | <u>Model</u> | <u>Manufacturer</u> | <u>ID No.</u> | <u>Last Cal Date</u> |
|---------------------------------------|--------------|---------------------|---------------|----------------------|
| QuasiPeak Adapter (10 kHz – 1 GHz) | 85650A | Hewlett Packard | U182 | 3/3/00 |
| Spectrum Analyzer Display | 85662A | Hewlett Packard | U181 | 3/2/00 |

| | | | | |
|---|----------------|--------------------------------|-------|--------------------------------------|
| Spectrum Analyzer (10 kHz - 1.5 GHz) | 8568B | Hewlett Packard | X718 | 3/2/00 |
| RF Receiver | ESV | Polorad | U965 | 8/3/00 |
| Magnetic Field Antenna (300 Hz to 100 MHz) | BBH – 500/B | Antenna Research Associates | V640 | 11/05/99 |
| Bi-Log Antenna (25 MHz to 1000 MHz) | LFB-2520 | ARA | B-962 | 6/23/99 (extended to 12/23/00) |

6.2 Conducted Emission Test

6.2.1 Conducted Emission Test Procedure

Peak amplitude terminal voltage emissions at the power line input to the EUT(s) were measured with a spectrum analyzer, using a peak detector and the appropriate CISPR bandwidth, connected to the RF output of a 50 Ohm, 50 micro-henry Line Impedance Stabilization Network (LISN) installed in each power line. Measurements were made over the frequency range from 150 kHz to 30 MHz while the EUT(s) was operating as described in paragraph 5.3.

The significant amplitudes of emissions measured on the AC power lines of the EUT(s) are recorded in this report in units derived as follows:

$$\text{Peak Emission (dBuV PK)} = \text{Meter reading (dBuV)} + \text{LISN factor (dB)} + \text{Limiter Loss (dB)}$$

Note: For speed and convenience, a spectrum analyzer employing a peak detector was used as the measuring receiver to sweep through and record the spectrum. As a tool to judge compliance of the emissions, the peak detector sweep is displayed and graphed against the appropriate average limit. This type of measurement is valid given that the peak reading will always be greater than or equal to the average or quasi-peak reading. Peak emissions recorded with the spectrum analyzer that exceed the average limit, or are found to be within 1 dB of the average limit are re-measured using an manually tuned receiver with the detector function first set to quasi-peak and then to average. These measurements are recorded and presented in the Section 6.2.2 of this report.



Photo 5 – Conducted Emissions Test Setup – Front View

6.2.2 Conducted Emissions Test Results 150kHz – 30 MHz (10/30/2000)

The conducted emissions recorded on the AC power cord of the RFID Tag Pad Reader (Serial) Model 741407, displayed against the limits for FCC Class B devices are presented as below. The quasi-peak detector reading exceeded the average detector reading for each frequency by more than 6 dB. Therefore according to 47 CFR Part 15.207 (d), the quasi-peak reading is reduced by 13 dB.

Table 8 – Conducted Emissions, RFID Tag Pad Reader (Serial) Model 741407, Neutral line (120 VAC/60 Hz)

| Frequency (MHz) | Quasi-peak Emission Amplitude (dBuV) | Correction Factor (dB) | Corrected Level (dBuV) | Broadband Adjustment -13 dB | FCC Class B Limit (dBuV) | QP Limit Margin (dB) |
|-----------------|--------------------------------------|------------------------|------------------------|-----------------------------|--------------------------|----------------------|
| .45217 | 33.20 | 10.459 | 43.659 | 30.66 | 47.96 | -17.30 |
| .47966 | 31.32 | 10.442 | 41.762 | 28.76 | 47.96 | -19.20 |
| .50586 | 28.33 | 10.427 | 38.757 | 25.76 | 47.96 | -22.20 |
| .52692 | 25.45 | 10.414 | 35.864 | 22.86 | 47.96 | -25.10 |
| .82535 | 29.40 | 10.265 | 39.665 | 26.67 | 47.96 | -21.29 |
| .84040 | 29.13 | 10.250 | 39.380 | 26.38 | 47.96 | -21.58 |

Table 9 – Conducted Emissions, RFID Tag Pad Reader (Serial) Model 741407, Phase Line (120 Vac/60 Hz)

| Frequency (MHz) | Quasi-Peak Emission Amplitude (dBuV) | Correction Factor (dB) | Corrected Level (dBuV) | Broadband Adjustment -13 dB | FCC Class B Limit (dBuV) | QP Limit Margin (dB) |
|-----------------|--------------------------------------|------------------------|------------------------|-----------------------------|--------------------------|----------------------|
| .46082 | 35.38 | 10.451 | 45.831 | 32.83 | 47.96 | -15.13 |
| .47060 | 35.54 | 10.444 | 45.984 | 32.98 | 47.96 | -14.98 |
| .49596 | 35.02 | 10.423 | 45.443 | 32.44 | 47.96 | -15.52 |
| .51500 | 34.06 | 10.411 | 44.471 | 31.47 | 47.96 | -16.49 |
| .53886 | 32.36 | 10.397 | 42.757 | 29.76 | 47.96 | -18.20 |
| 2.0359 | 42.87 | 10.142 | 53.012 | 40.01 | 47.96 | -7.95 |

- Overall Results: All conducted emissions measured on the input AC power lines of the RFID Tag Pad Reader (Serial) Model 741407, are below the FCC Class B limit.

6.2.3 Conducted Emissions Test Equipment

The following equipment was used during conducted disturbance testing of the EUT.

| <u>Equipment</u> | <u>Model</u> | <u>Manufacturer</u> | <u>ID No.</u> | <u>Last Cal Date</u> |
|---|--------------|---------------------|---------------|----------------------|
| QuasiPeak Adapter (10 KHz – 1 GHz) | 85650A | Hewlett Packard | X717 | 3/2/00 |
| Spectrum Analyzer Display | 85662A | Hewlett Packard | U181 | 3/2/00 |
| Spectrum Analyzer (10 kHz - 1.5 GHz) | 8568B | Hewlett Packard | X718 | 3/2/00 |
| LISN | 8121 | Schwarzbeck | U774 | 2/2/00 |

6.3 Frequency Stability Test (11/9/00)

6.3.1 Frequency Stability Test Procedure

The test sample was placed in an environmental chamber at 20°C and allowed to stabilize (minimum 30-minute soak). The nominal operating frequency was measured at this time with a small loop probe connected to a spectrum analyzer.

The test sample was then powered off and allowed to stabilize. With the AC input voltage at 115% of nominal, the test sample was powered on and operating frequency measurements were

made at 0, 2, 5 and 10 minutes after power on. This procedure was repeated for all required temperature and voltage conditions.

6.3.2 Frequency Stability Test Results

The following table shows the frequency deviation measured on a sample of the transmitter board compared to FCC 15.225 limits of .01% with respect to temperature and input AC voltage.

Table 10 – Temperature Stability Table

| Condition | Time[min] | Frequency[Hz] | % Deviation from nominal | Result |
|-------------------------------|-----------|---------------|--------------------------|-------------|
| 20°C/122VAC (Nominal) | N/A | 13560000 | N/A | N/A |
| 20°C/138 VAC (115% Nom AC) | 0 | 13560000 | <<0.01% | Below limit |
| | 2 | 13560000 | <<0.01% | Below limit |
| | 5 | 13560004 | <<0.01% | Below limit |
| 20°C/102 VAC (85% Nom AC) | 10 | 13560010 | <<0.01% | Below limit |
| | 0 | 13560000 | <<0.01% | Below limit |
| | 2 | 13560002 | <<0.01% | Below limit |
| 50°C/122 VAC (High Temp) | 5 | 13560005 | <<0.01% | Below limit |
| | 10 | 13560005 | <<0.01% | Below limit |
| | 0 | 13560000 | <<0.01% | Below limit |
| -20°C/122 VAC (Low Temp) | 2 | 13560003 | <<0.01% | Below limit |
| | 5 | 13559991 | <<0.01% | Below limit |
| | 10 | 13559986 | <<0.01% | Below limit |
| -20°C/122 VAC (Low Temp) | 0 | 13560000 | <<0.01% | Below limit |
| | 2 | 13560000 | <<0.01% | Below limit |
| | 5 | 13555999 | <<0.01% | Below limit |
| | 10 | 13559996 | <<0.01% | Below limit |

Overall Results: The RFID Tag Pad Reader (Serial) Model 741407 complied with the requirements of FCC 15.225 for frequency stability by a worst case deviation of 14 Hz or $100 \times 14 / 13560000 = 1.032E-4$ %.

6.3.3 Frequency Stability Test Equipment**Table 11 – Frequency Stability Test Equipment**

| <u>Equipment</u> | <u>Model</u> | <u>Manufacturer</u> | <u>ID No.</u> | <u>Last Cal Date</u> |
|-------------------------------------|---------------------|----------------------------|----------------------|-----------------------------|
| Temperature/Humidity Chamber | SM32C | Thermotron | V733 | 6/21/00 |
| Spectrum Analyzer Display | 85662A | Hewlett Packard | Y0314 | 3/3/00 |
| Spectrum Analyzer (100 Hz - 22 GHz) | 8566B | Hewlett Packard | Y0313 | 3/3/00 |
| Multimeter | 8021 | Fluke | X743 | 10/21/00 |
| Variable Transformer | 136-2 | Powerstat | W582 | N/R |