

**10071753**

**USER'S MANUAL  
NP10 AND NP20**

**Title:**

**NOTICE TO PERSONS RECEIVING THIS DRAWING  
AND/OR TECHNICAL INFORMATION:**

Checkpoint Systems claims propriety rights to the material disclosed hereon. This drawing and/or technical information is issued in confidence for engineering information only and may not be reproduced or used to manufacture anything shown or referred to hereon without direct written permission from Checkpoint Systems to the user. This drawing and/or technical information is the property of Checkpoint Systems and is loaned for mutual assistance, to be returned when its purpose has been served.

**THIS DRAWING AND/OR TECHNICAL INFORMATION IS THE PROPERTY OF  
CHECKPOINT SYSTEMS, INC.**

**REVISIONS**

**REVISIONS**

REV	DESCRIPTION	DATE	ENGINEER
00	CR2660AB	05/30/18	S. SINGH

REV	DESCRIPTION	DATE	APPROVED

		DOC SPEC	DATES
		DWN M. KEGELMAN	05/30/18
		CHK	
		ENG S. SINGH, K. ZENG, R. OLSON	05/30/18
		APPD	



**Used On**

<b>Size A4</b>	<b>10071753</b>
Scale: N/A	© Checkpoint Systems, Inc. 2018 Page 1 of 14

## Important Information to our Users in North America

### FCC Regulatory Compliance Statement

Checkpoint Systems, Inc., offers Electronic Article Surveillance (EAS) or Radio Frequency Identification Products that have been FCC certified or verified to 47 CFR Part 15 Subparts B/C. Appropriately, one of the following labels will apply to the approval:

NOTE: This equipment has been tested and found compliant within the limits for a class A digital device, pursuant to Part 15 of the FCC Rules. These limits are designed to provide reasonable protection against harmful interference when the equipment is operated in a commercial environment. This equipment generates, uses, and can radiate interference to radio communications. Operation of this equipment in a residential area is likely to cause harmful interference in which case the user will be required to correct the interference at own expense.

- OR -

This device complies with Part 15 of the FCC Rules. Operation is subject to the following two conditions: (1) including this device may not cause harmful interference, and (2) this device must accept any interference received, including interference that may cause undesired operation, which may include intermittent decreases in detection and/or intermittent increases in alarm activity.

**WARNING:** Changes or modifications to Checkpoint's EAS or Radio Frequency Identification (RFID) equipment not expressly approved by the party responsible for assuring compliance could void the user's authority to operate the equipment in a safe or otherwise regulatory compliant manner.

The installation location of the NEO Antenna radiating structure must provide a minimum of 20cm [8in] separation between the antenna and the human body.

### Industry Canada Regulatory Compliance Statement

This device complies with the Industry Canada license-exempt RSS standard(s). Operation is subject to the following two conditions:

1. This device may not cause interference, and
2. This device must accept any interference, including interference that may cause undesired operation of the device.

Le fonctionnement de l'appareil est soumis aux deux conditions suivantes:

- (1) Cet appareil ne doit pas perturber les communications radio, et
- (2) cet appareil doit supporter toute perturbation, y compris les perturbations qui pourraient provoquer son dysfonctionnement.

### Equipment Safety Compliance Statement

Checkpoint's Electronic Article Surveillance (EAS) products have been designed for safeness during normal use and, where applicable have been certified, listed, or recognized in accordance with one or more of the following safety standards; UL 60950-1, CSA C22.2 No. 60950-1-07. Additional approvals may be pending.

**WARNING:** Changes or modifications to Checkpoint's EAS equipment not expressly approved by the party responsible for assuring compliance could void the user's authority to operate the equipment in a safe or otherwise regulatory compliant manner.

## Important Information to our Users in Europe

### CE Regulatory Compliance Statement

Where applicable, Checkpoint Systems, Inc. offers certain Electronic Article Surveillance (EAS) products that have CE Declarations of Conformity according to R&TTE Directive 99/5/EC, EMC Directive 2004/108/EC, and Low Voltage Directive 2006/95/EC.

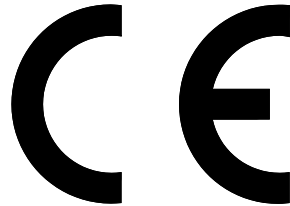

System Electromagnetic Compatibility (EMC) has been tested and notified through Spectrum Management Authorities if necessary, using accredited laboratories, whereby, conformity is declared by voluntarily accepted European Telecommunications Standards Institute (ETSI) standards EN 301489-3 and EN 302208 and/or EN 300330, as applicable.

NOTE: Certain Electronic Article Surveillance (EAS) equipment have been tested and found to conform to the CE emission and immunity requirement in Europe. This equipment generates, uses, and can radiate radio frequency energy and, if not installed and used in accordance with the instruction manual, may cause harmful interference to radio communications. Under unusual circumstances, interference from external sources may degrade the system performance, which may include intermittent decreases in detection and/or intermittent increases in alarm activity. However, there is no guarantee that interference will not occur in a particular installation. If this equipment experiences frequent interference from external sources or does cause harmful interference to radio communications reception, which can be determined by turning the equipment off and on, please contact a Checkpoint Systems representative for further assistance.

### RoHS Compliance Statement

The RoHS Directive stands for "the restriction of the use of certain hazardous substances in electrical and electronic equipment." A RoHS compliant product means that electrical and electronic equipment cannot contain more than maximum permitted levels of lead, cadmium, mercury, hexavalent chromium, polybrominated biphenyl (PBB) and polybrominated diphenyl ether (PBDE). Checkpoint is in compliance with the RoHS directive.

### WEEE Compliance Statement

The Waste Electrical and Electronic Equipment Directive (WEEE) applies to companies that manufacture, sell, distribute, or treat electrical and electronic equipment in the European Union. There are a number of obligations imposed on Checkpoint as a supplier of electrical and electronic equipment. Checkpoint's compliance approach for each of these obligations is provided below.

### **WEEE Marking**

All products that are subject to the WEEE Directive supplied by Checkpoint are compliant with the WEEE marking requirements. Such products are marked with the "crossed out wheellie bin" WEEE symbol shown below in accordance with European Standard EN 50419.

### **Information for Users**

According to the requirements of European Union member state WEEE legislation, the following user information is provided in English for all Checkpoint supplied products subject to the WEEE directive.



This symbol on the product or on its packaging indicates that the product must not be disposed of with normal waste. Instead, it is your responsibility to dispose of your waste equipment by arranging to return it to a designated collection point for the recycling of waste electrical and electronic equipment. By separating and recycling your waste equipment at the time of disposal you will help to conserve natural resources and ensure that the equipment is recycled in a manner that protects human health and the environment. For information about how to recycle your Checkpoint supplied waste equipment, please contact the Checkpoint Systems, Inc. Field Service office in your region. Customers can obtain this information from their system User Guide.

### **REACH Compliance Statement**

The European REACH Regulation 1907/2006 on Registration, Evaluation, Authorization, and Restriction of Chemicals (REACH), Annex XVII entered into force in June 2009, and affects all companies producing, importing, using, or placing products on the European market. The aim of the REACH regulation is to ensure a high level of protection of human health and the environment from chemical substances.

Checkpoint Systems' substances management system follows and complies with the current revision of the REACH Regulation on the substances as identified by ECHA (European Chemical Agency).

Checkpoint Systems' products are considered articles as defined in REACH Article 3 (3).

These products/articles under normal and reasonable conditions of use do not have intended release of substances. Therefore the requirement in REACH Article 7 (1) (b) for registration of substances contained in these products/articles does not apply.

Checkpoint Systems' products/articles do not contain Substances of Very High Concern or if there are SVHC in the product/article, the content is less than the 0.1% (wt/wt) as defined by REACH Article 57, Annex XIV, Directive 67/548/EEC. Therefore the requirement in REACH Article 7 (2) to notify ECHA if a product/article contains more than 0.1% wt/wt of an SVHC and tonnage exceeding 1 tonne per importer per year is not applicable.

Checkpoint Systems' European operations do not manufacture or import chemicals, therefore Checkpoint Systems no obligation to register substances.

### **Packaging Compliance Statement**

No CFCs (chlorofluorocarbons), HCFCs (hydrofluorocarbons) or other ozone depleting sub-stances are used in packaging material. Chromium, lead, mercury, or cadmium are not intentionally added to packaging materials and are not present in a cumulative concentration greater than 100 ppm as incidental impurities. No halogenated plastics or polymers are used for packaging material. Checkpoint complies with the EU Directive 94/62/E.

## TABLE OF CONTENTS

1.0	INTRODUCTION.....	6
1.1	<i>Comparing NP10 and NP20</i> .....	6
1.2	<i>System Models in Product Family</i> .....	7
2.0	GENERAL DESCRIPTION .....	8
2.1	<i>EAS Features</i> .....	8
2.1.1	Radio Frequency Band .....	8
2.1.2	Electronic Mode of Operation.....	8
2.1.3	Configurable alarm sound/light color.....	8
2.1.4	External USB Interface, GPIO Interfaces.....	8
2.2	<i>System Controller</i> .....	8
2.2.1	Light and Speaker Board.....	9
2.2.2	USB Port Usage .....	9
2.3	<i>EAS Sensor</i> .....	9
2.4	<i>Remaining Hardware</i> .....	9
3.0	SPECIFICATIONS .....	10
3.1	<i>Overall Size</i> .....	10
3.2	<i>EAS Sensor</i> .....	10
3.3	<i>System Controller</i> .....	11
3.4	<i>Light and Speaker Board</i> .....	11
3.5	<i>IO Board (GPIO Module)</i> .....	12
3.6	<i>Audio Speaker</i> .....	12
3.7	<i>LED Board</i> .....	13
3.8	<i>Environmental</i> .....	13
4.0	USING DMS TO APPLY SOFTWARE SETTINGS.....	13
5.0	POWER SUPPLY REQUIREMENTS .....	13
6.0	DEVICE LABELING .....	14

## LIST OF FIGURES

FIGURE 1: NP10 .....	5
FIGURE 2: NP20 .....	6

## LIST OF TABLES

TABLE 1: AVAILABLE SYSTEM MODELS .....	7
TABLE 2: POWER CONNECTOR PIN ASSIGNMENTS .....	14

### 1.0 INTRODUCTION

NEO Antennas NP10 and NP20 are advanced solutions for product protection, anti-theft and retail operations support. The NEO system has been designed with upgrades in mind. This document introduces the TR4300 (CKP P/N 1005310) – the reader board that yields NEO’s functionality as an Electronic Article Surveillance (EAS) platform.

Each NEO Antenna is outfitted with one TR4300 and just like previous EAS pedestals developed and sold by Checkpoint Systems, detection can be achieved in the single pedestal configuration and also in a two-pedestal (called “Single Aisle”) and multi-aisle floorplans/layouts.

NEO’s System Controller interfaces with the TR4300. This on-board computer sends and receives communications. NEO is to be configured at the time of installation by Checkpoint Field Service.

### 1.1 Comparing NP10 and NP20

The differences between NP10 and NP20 are minimal. The NP10 has larger antenna loops because the mechanical frame is wider.

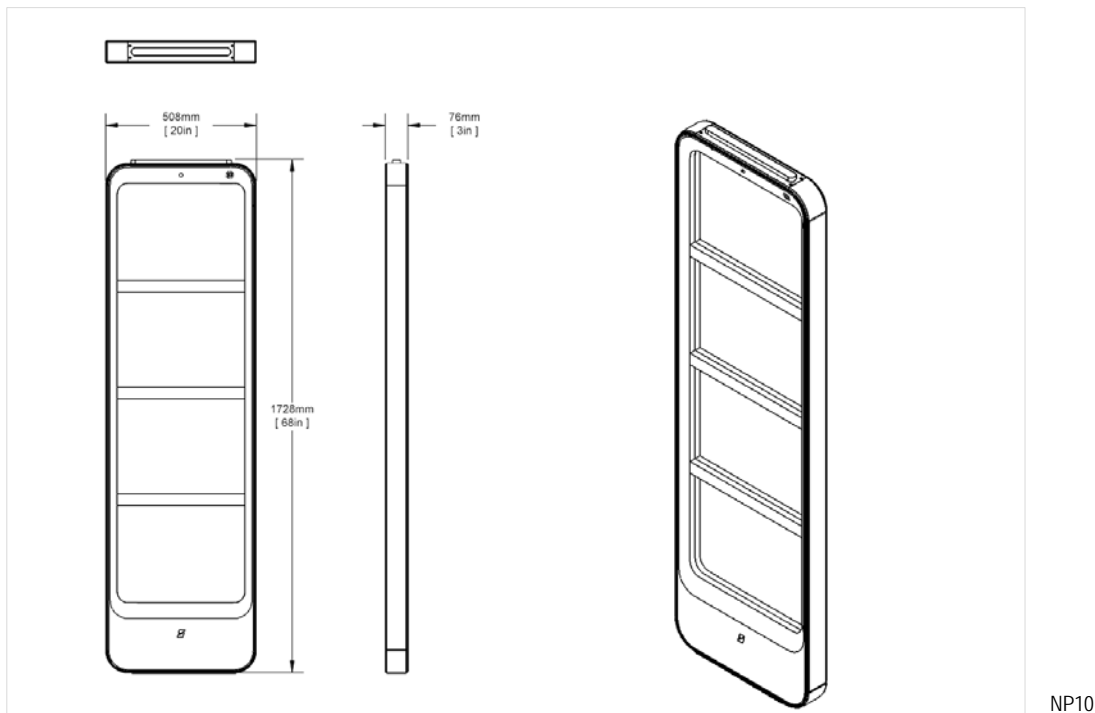

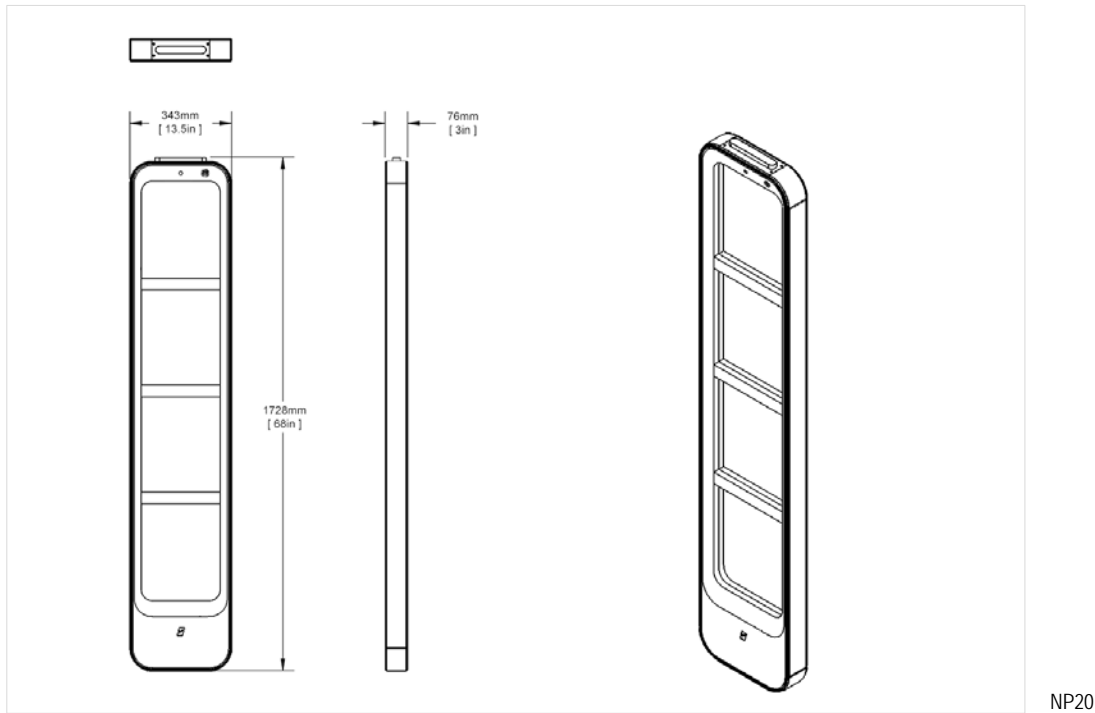

Measurements rounded to nearest mm and nearest 1/8th inch.

Besides some cabling differences and the selection of the LED Board and Antenna Matching Coupler Board tuned to match the RF loop characteristics of the larger system, NP10 and NP20 systems are very consistent. In general, NP10 and NP20 are the same platform.

## 1.2 System Models in Product Family

Table 1 below shows the main system SKUs. All NEO units listed are “PRI” (Primary), with an EAS Sensor and System Controller, as well as the supporting PCB boards and USB devices described in this document.

Table 1: Available System Models

Model Name	System SKU	Description
<b>NP10</b>	10039741	*NP10 PRI WHT
	10054864	*NP10 PRI GREY RAL 7024
<b>NP20</b>	10066694	*NP20 PRI WHT
	10048562	*NP20 PRI GREY RAL 7024

Accessories (such as an Ad Panel) are outside the scope of this document. Dual RF/RFID models (both technologies in the same pedestal) are currently under development.

## 2.0 GENERAL DESCRIPTION

### 2.1 EAS Features

#### 2.1.1 Radio Frequency Band

##### **Detection Limited to 8.2 MHz**

- No “Application Based Detection Mode” (7.6, 9.0 detection).
- NEO is tuned to achieve detection of HF targets at 8.2MHz  $\pm$ 5% radio frequency.
- Tags tuned to other frequencies may or may not produce the alarm; expect a noticeable drop in performance for any non 8.2 tag.
- By product management and design team choice, working from voice of customer, the feature was removed intentionally. Now the only supported band is 8.2 - different from Evolve/Liberty Systems. Currently for NEO Antennas, please consider alternative tuning & dual frequency no longer supported.

#### 2.1.2 Electronic Mode of Operation

Each NEO operates as an EAS detector with pulse-listen technology (same platform as Evolve).

Currently NEO **does not support the Primary/Secondary configuration.**

#### 2.1.3 Configurable alarm sound/light color

Using DMS (see [section 4.0](#)), the Field Service Technician is able to choose from a set of pre-loaded Sound Files (.mp3 format) or otherwise import a file, a replacement sound requested by the customer, then assign it as the default EAS Alarm sound. The color is also selectable from a range of visual colors and intensities.

#### 2.1.4 External USB Interface, GPIO Interfaces

NEO's EAS Sensor has a USB Type B port at the top. A long USB cable extends from the EAS Sensor's location to the system controller. This is called the **lower to upper bay data connection**.

NEO also features a simple I/O board. It has RJ-45 connectors to provide inputs/outputs and an RS-232 interface. Some (or even most) installations will not feature anything connected to these ports. External devices that use a relay contact pair (for example, a DVR Trigger) can be supported.

## 2.2 System Controller

Every NEO has an EAS Sensor and the (factory installed) antenna wiring, a system controller and control cabling, and the power supply. The System Controller is one of the central devices. USB devices and the Light and Speaker board interface directly with it.

The 64-Bit processor manages alarms from the EAS sensor, and other critical aspects such as storage of configuration data and event data. It relies on the USB ports (one high-speed USB 3.0 port for the EAS Sensor) and an Ethernet port (used only by field service).

The system controller receives 5.0V / 3A regulated DC power from a Light and Speaker Board covered in section 2.2.1 below.



### 2.2.1 Light and Speaker Board

The Lights and Speaker board mates directly with the system controller. +24V DC power arrives from the lower bay. The PCB features power regulators, an Audio amplifier, and a RGB Light driver.

### 2.2.2 USB Port Usage

Wi-Fi and Bluetooth USB dongles are two independent devices that are featured standard. As mentioned, the third available port is a USB 3.0/2.0 connector that is for the EAS Sensor, covered next.

## 2.3 EAS Sensor

The TR4300 TX/RX transceiver is the electronics PCB system of a pulse-listen Electronic Article Surveillance (EAS) detection system which utilizes targets that are applied to merchandise. There are no jumpers on the TR4300. Like earlier “Evolve” main boards, the TR4300 has an FPGA (field programmable gate array) with processor and memory functions. There is a USB interface with the system controller. Metal Shields are equipped (separate shields for Rx and Tx circuit sections). Check for tightness.

For the device to detect real alarm events and not trigger due to “phantoms,” the EAS Sensor has electronic tuning and digital signal processing.

The tuning of the system is the Field Service Technician’s responsibility. The NEO Installation Manual (CKP P/N 10078945) will provide instructions.

## 2.4 Remaining Hardware

The LED Board is a 24V DC / 60mA powered device with three individual LED colors per LED. The varying voltages applied to the set of three LEDs will illuminate the overall LED in the color of light to be produced. This control is achieved by the Light and Speaker board, which gets the instructions from the controller where user settings can be applied (i.e. change the default).

NEO also has a speaker which is quite different from earlier Checkpoint “Buzzers.” (Piezoelectric transducers were formerly used, whereas this is a magnetically driven voice-coil and pole-piece type loudspeaker.) It can play back an infinite range of acoustic sounds. The frequency range is roughly 150 Hz to 20 kHz. More details on the audio speaker are covered in Specifications below.

The wiring harnesses are all installed and tested at the time of manufacture.

Depending on application, the controller will utilize a different device than the standard Wi-Fi antenna (USB device). At the time of installation or service visit for reconfiguration, the Wi-Fi antenna can be replaced by a cell-modem module. There are 3 versions for FCC, EU and APAC specific regulatory approval. All devices provide the same functionality of 4G LTE cellular data upload/download.

## 3.0 SPECIFICATIONS

### 3.1 Overall Size

NP10:

Height: 172.78cm [68.02in]

Width: 50.75cm [19.98in]

Depth (front to back): 7.62cm [3.00in]

NP20:

Height: 172.78cm [68.02in]

Width: 34.26cm [13.49in]

Depth (front to back): 7.62cm [3.00in]

### 3.2 EAS Sensor

Mechanical Specs:

PCB Layers: 8

PCB Materials: FR4

Dimensions: L X W: 116mm X 170mm [4.567in X 6.693in]

Electrical Specs:

DC Input / Output: +24V (other voltages are available using GPIO and connectors)

Clock Speed: 100 MHz

Clock Speed: 12.000 MHz

Connector function (Number): Connector type

Power Input / Output (2): 3-Pin 3.5mm connector, keyed

Power Output to Upper Bay (1): 3-Pin 3.5mm connector, keyed

Power Output for expansion module (1): 3-Pin 3.5mm connector, keyed

RF Antenna outputs (2): 2-Pin 3.5mm connector, keyed

USB Serial port (1): USB Type B connector, shielded

IO Board (GPIO module) B2B connector (1): 2 x 12 Header PCB-mount, Right Angle

Expansion (e.g. Hub board) B2B connector (1): 2 x 12 Header PCB-mount, Right Angle

### 3.3 System Controller

Mechanical Specs:  
Small PCB about the size of a credit card

Electrical Specs:  
CPU: 64-Bit Processor  
Memory: 1GB 1600MHz LPDDR3 memory; 16GB

Connector function (Number): Connector type  
Data Interface to/ from LnS Board (1): Header 2 x 20 PCB mounted, Female socket  
Power input: DC power supplied from the Light and Speaker board (thru 2 x 20 header pins)  
USB serial interface: USB Type A ports (3). All 3 ports in use.  
Exchange Wi-Fi module for your region's cell-modem module when the Site Architecture is cellular data reporting and/or cloud-based site monitoring.  
Audio output: Stereo output, bare leads are soldered to the PCB terminals to reduce space  
Ethernet connector: Not in use (except for field service and/or MFG needs)  
HDMI port: \*not in use

### 3.4 Light and Speaker Board

Mechanical Specs:  
PCB Layers: 4  
PCB Materials: FR4  
Dimensions: L X W: 56mm X 100mm [2.2in X 3.94in]

Electrical Specs:  
DC Power Input: 24V DC  
Regulated Outputs: 5V DC

Connector function (Number): Connector type:  
Power Input (1): 2-Pin Euro Plug F connector (CKP P/N 7100784) included as part of PWR cable assemblies (for lower to upper power NP10 uses 10045277; NP20 uses 10090050).  
Data Interface to/ from controller (1): Header 2 x 20 pins, Male pins

Light and Speaker Board continued...

Speaker 2-Pin mini jack (1): Hirose 2-Pin port, keyed  
LED 7-Pin mini jack (1): Hirose 7-Pin port, keyed  
System Controller Audio Input 3-Pin mini jack (1) Hirose 3-Pin port, keyed  
USB Connector (1): USB Mini-C connector for interface to controller

### **3.5 IO Board (GPIO Module)**

Mechanical Specs:  
PCB Layers: 4  
PCB Materials: FR4  
Dimensions: 32.5mm X 76.5mm [1.28in X 3.01in]

Electrical Specs:  
Inputs: 4. RJ-45 connector (2 pins per input).  
Outputs: 2. The GPO RJ-45 connector has 4 relay contact pairs in total. 2 Normally Open (N.O.) and 2 Normally Closed (N.C.). Each output drives an open and closed contact pair.  
RS-232 serial data interface (intended only for support of CPiD-RF): 1  
Connectors: 3 RJ-45, and 2 x 12 header male, pre-installed B2B with EAS Sensor.

### **3.6 Audio Speaker**

Mechanical Specs:  
Dimensions: 2" diameter  
Square frame: OD of frame is approximately

Electrical Specs:  
Impedance: 4 Ohm  
Frequency response: Full range speaker (150 Hz - 20 KHz)  
Terminals: Soldered  
Wire type: 26 AWG PVC, stranded wires (Red and Black color)  
Connector, Lights and Sound Board side (speaker output terminal): Hirose DF13-2S-1.25C  
Crimp Terminals: Hirose DF13-2630SCFA(04), Qty 2.

### 3.7 LED Board

Mechanical specs:

PCB Layers: 2

PCB Materials: FR4

Dimensions: NP10 - 319.5mm X 12mm [12.58in X 0.47in]

NP20 - 156.0mm X 12mm [6.14in X 0.47in]

Features: 10 LEDs aligned in a row.

Each LED can illuminate in various colors, relying on 3 individual LEDs (Red, Green, and Blue) inside each of the 10 PCB-mounted LEDs.

Electrical specs:

Connector port (1): 7-Pin Hirose connector

Required Cable (available as a FS spare): ^CABLE ASSY,LED NEO (10056250)

Power input rating: 24V / 60mA

### 3.8 Environmental

All the internal electronics shall meet or surpass the listed environment specifications:

Operating Temperature: 0° to + 60° C

Non-Condensing Relative Humidity: 5% to 95%

## 4.0 USING DMS TO APPLY SOFTWARE SETTINGS

Checkpoint DMS is **by-license-only** software, which will be used by field service, engineering and manufacturing to set up NEO.

Tuning can be performed using DMS. Transmit Power and other critical settings are checked/set with the help of Analog View and similar software features. DMS is also used at the time System installation to pick the LED color, pattern and the sound file (.mp3) played when the EAS Alarm Event occurs.

## 5.0 POWER SUPPLY REQUIREMENTS

NEO requires +24 VDC supplied at J6 or J14 of the EAS Sensor.

An external AC-DC converter power supply rated at 24VDC nominal, with 90W max. power limiting feature, complying with IEC/UL 60950-1 2nd Ed.+Am1 and evaluated to clause 2.5 (LPS) of the mentioned standards is required. Only use 1 power connector as

the DC Power input (i.e. do not connect 2 power supplies directly to 1 reader). J6 and J14 are wired in parallel, allowing the installer to daisy chain a second RF Only system; use only the approved power supply for your region; in FCC use 10043582. The third bottom row connector port (J3) is for future expansion.

The DC power wire must be 3 conductor (2C w/ drain wire), 18 AWG or greater, maximum 10m [32.8ft]. The PSU drain wire is grounded to chassis GND with crimp terminal. A small bracket with ground lugs will be described in the installation manual.

The connector pinout for DC power INPUT connector is below:

Table 2: Power Connector Pin Assignments

PIN # ON TR4300 (J6/J14)	COLOR	SIGNAL	EXAMPLE
1	Bare wire (shield/ drain wire)	Chassis Ground (GND)	
2	Red	+24V	
3	Black	GND	

Note: Other internal factory wiring will be detailed in reference sections in the Field Service manual.

## 6.0 DEVICE LABELING

Each NEO will have a label, found in the base region, which indicates this specific unit's Model Name, part number, revision and the serial number of the unit manufactured, as well as regulatory information. For example:

FCC ID: DO4NEO

This device complies with Part 15 of the FCC Rules.

Operation is subject to the following two conditions:

- (1) this device may not cause harmful interference, and
- (2) this device must accept any interference received, including interference that may cause undesirable operation.