

**ELECTROMAGNETIC INTERFERENCE TEST REPORT**

**Doc. 20040104R**

**Project No. 980**

**TEST STANDARDS: USA 47 CFR PART 15**

**ILS Non-contact Programmer 2.0**

**FCC ID: DO4NCPRW7000**

**CHECKPOINT SYSTEMS, INC.**

**THOROFARE, NEW JERSEY**

**TEST DATE: September 03 to September 22, 2003**

**ISSUE: January 10, 2004**

Prepared by: \_\_\_\_\_



Paul Banker  
Technical Staff Engineer

Approved by: \_\_\_\_\_



John Baumeister  
Group Manager, PCTC/ICC

The results described in this report relate only to the item(s) tested.  
This document shall not be reproduced except in full without written permission of Unisys - PCTC.



**AMERICAN ASSOCIATION FOR LABORATORY ACCREDITATION**

Certificate No: 1028.01

### PREFACE

This report documents product testing conducted to verify compliance of the specified EUT with applicable standards and requirements as identified herein. EUT, test instrument configurations, test procedures and recorded data are generally described in this report. The reader is referred to the applicable test standards for detailed procedures. The following table summarizes the test results obtained during this evaluation.

### SUMMARY

The ILS Non-contact Programmer 2.0 was tested to the standards listed below, and found to have the following characteristics:

TEST	STANDARD	Frequency Range	RESULT
Radiated Emissions Intentional Radiator, Fundamental	FCC Part 15.225	13.553 to 13.567 MHz	Below Max. Permissible Limit
Radiated Emissions Intentional Radiator, Harmonics	FCC Part 15.209	10 MHz to 1 GHz	Below Max. Permissible Limit
Radiated Emissions Unintentional Radiator (Related to Digital Circuitry)	FCC Part 15.109	30 MHz to 1 GHz	Below Max. Permissible Limit
Conducted Emissions Unintentional & Intentional Radiators	FCC Part 15.107 Part 15.207	150 kHz to 30 MHz	Below Max. Permissible Limit
Frequency Tolerance	47 CFR Part 15.225	13.553 – 13.567 MHz	Within .01 % tolerance

### EUT Modifications

Two ferrite cores were added to each end of the DC output line of the Deltron 11985A Adapter.

MEASUREMENT UNCERTAINTY				
Measurement Type	Measurement Distance	Frequency Range	Measurement Limit	Expanded Combined Uncertainty
Radio Disturbance	10 meters	30 MHz to 1 GHz	Class A	4.3 dB
Radio Disturbance	3 meters	30 MHz to 1 GHz	Class B	4.3 dB
Conducted Disturbance	N/A	150 kHz to 30 MHz	Class A or B	3.6 dB

As all values of uncertainty are less than the CISPR/A/355/FDIS (CISPR 16-4/FDIS) recommendations, no adjustments to measured data presented in this report are required.

TABLE OF CONTENTS

1.0	Description of The Equipment Under Test (EUT).....	4
1.1	General Description .....	4
1.2	Test Configurations.....	5
1.3	Rationale for The Chosen Configuration.....	6
1.4	EUT Modifications.....	6
2.0	Operation of The EUT During Testing .....	7
2.1	General.....	7
2.2	Operating Mode .....	7
2.3	Rationale for The Chosen Mode of Operation .....	7
3.0	Applicable Requirements, Methods and Procedures.....	8
3.1	Applicable Requirements .....	8
3.2	Basic Test Methods and Procedures.....	8
3.3	Deviations Or Exclusions From The Requirements And Standards.....	8
4.0	Test Results .....	8
4.1	Radiated Emissions .....	8
4.1.1	Test Facility.....	8
4.1.2	Radiated Emissions Test Procedure .....	9
4.1.3	Radiated Emissions Test Results (9/16 – 9/19/2003).....	10
4.2	Conducted Emissions .....	14
4.2.1	Conducted Emission Test Procedure.....	14
4.2.2	Conducted Emissions Test Results (9/22/2003).....	14
4.3	Frequency Tolerance Test .....	17
4.3.1	Frequency Tolerance Test Procedure .....	17
4.3.2	Frequency Tolerance Test Results (10/3/2003).....	17
	Appendix A – Test Equipment.....	19
	Appendix B: E-mail from FCC describing band-edge measurements.....	20

**1.0 Description of The Equipment Under Test (EUT)**

Equipment Identification	ILS Non-Contact Programmer
Model/Style Number	7267385
Serial Number	None
Manufacturer	Checkpoint Systems, Inc. 101 Wolf Drive Thorofare, NJ 08086
Technical Contact	Phil Lanese
Condition Received	Acceptable for Test
Date Received	5 September, 2003
Sample Type	Pre-production Unit
Equipment Classification	Professional Use Information technology Equipment (ITE)
Unisys Test Personnel	Paul Banker

Unless otherwise noted in the individual test results sections, testing was performed on the EUT configured as follows.

**1.1 General Description**

The ILS non-contact programmer is a 13.56 MHz based RFID read/write device for the purpose of programming RFID tags with user-defined data via an RF interface. The RFID tags are based upon the Microchip MCRF450 read/write IC. The non-contact programmer:

- Puts out a polling sequence seeking tags in its interrogation field.
- Reports the presence of those tags to the non-contact programmer software application via an Ethernet link
- Receives commands from the s/w application defining what user defined data is to be written to the detected tag.
- Translates the user-defined data into a command modulation sequence to write the data to the tag via the RF interface.
- Automatically handles errors and retry attempts in the tag processing
- Reports back to the s/w application the disposition of tag processing.



**Photograph of ILS Non-contact Programmer 2.0 and Deltron 11985 AC Adapter**

**1.2 Test Configurations**

**Block Diagram and Cable listing**

A block diagram of the EUT configuration showing interconnection cables is shown on the next page for reference. The drawing shows the physical hardware layout used for the tests along with I/O cables connection and AC power distribution. A description of any external interface cable present during the test is attached to this drawing for reference.

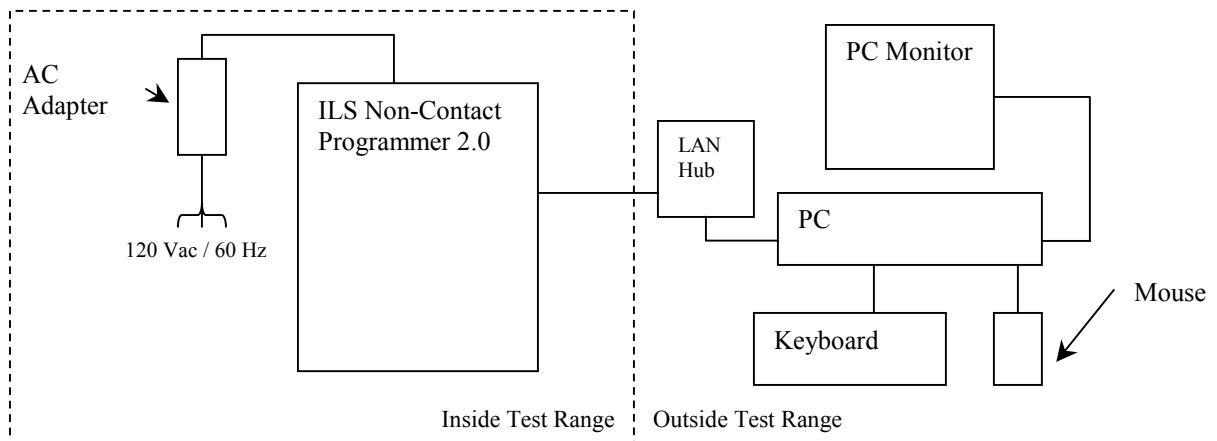

**EMI Test Setup Block Diagram of ILS Non-contact Programmer 2.0**

**Interconnection Cable List**

Cable Function	Cable shield Type	Cable Length
LAN cable PC to ILS	None	25'
DC power	None	7'
AC Power Line	None	6'

**Test Support Items**

Description	Manufacturer	Model/Part Number	Serial Number
Millenia Xru Personal Computer	Micron	Portland-PII-266-MT	996542-004
PC Monitor	elo Touchsystems	P284-ML6870A-5	MDIHA707505962
Keyboard	NMB Technologies	RT5862TW	C0851210
Mouse	Radio Shack	26-372	LZA7310289207A7
LAN Hub	CentreCom, Inc.	3016 SL, V3	S0N69311A

**Detailed EUT Hardware Listing**

Description	Manufacturer	Style/Part Number	Serial Number
ILS Non-Contact Programmer 2.0	Checkpoint Systems, Inc.	ILS Non-Contact Programmer	Prototype
AC Adapter	Deltron, Inc.	11985A	701200000143

**1.3 Rationale for The Chosen Configuration**

The above configuration contains all of the components, interface and power connections that will exist in field installations.

**1.4 EUT Modifications**

Two Ferrite cores were added each end of the power supply DC line. The modification was required to meet the radiated emission requirements. The manufacturer and part number are either: FairRite, p/n 2661540002 or Steward, p/n 25B0562-200

## **2.0 Operation of The EUT During Testing**

Unless otherwise noted in the individual test results sections, testing was performed on the EUT as follows.

### **2.1 General**

#### **Climatic Environment**

The following were the ambient conditions in the laboratory during testing:

Temperature:  $22^{\circ}\text{C} \pm 5^{\circ}\text{C}$

Relative Humidity  $50\% \pm 10\% \text{RH}$

#### **Selection of AC Power Voltage/Frequencies**

120 Volts AC / 60 Hertz power was used for all testing described in this report.

### **2.2 Operating Mode**

The ILS Non-contact Programmer 2.0 was connected to a 10 BaseT LAN that in turn connected to a PC host running Microsoft Windows NT version 4.0. The application used to read and write the RFID tags was titled "RFID Tag Programmer," a product of Checkpoint Systems, Inc. The version of RFID Tag Programmer was 1.00.0022.

An RFID programmable tag was attached to the end of a stick attached to the housing of an oscillating fan. The motion of the fan moved the tag in and out of the magnetic field produced by the EUT. The software would read the tag and automatically increment the tag identification number during each pass of the tag.

### **2.3 Rationale for The Chosen Mode of Operation**

The software used in test is the same software that the manufacturer delivers with the ILS system.

### **3.0 Applicable Requirements, Methods and Procedures**

#### **3.1 Applicable Requirements**

The results of the measurement of the radio disturbance characteristics of the EUT described herein may be applied and, where appropriate, provide a presumption of compliance to one or more of the following requirements or to other requirement at the discretion of the client, regulatory agencies, or other entities.

##### **USA**

47 CFR, Part 15, Subpart B, "Unintentional Radiators, General Rules and Regulations"

#### **3.2 Basic Test Methods and Procedures**

The applicable regulatory product family or generic standards require that radio disturbance/interference tests be performed in accordance with the following:

- C63.4, 2001 "Methods of Measurement of Radio-Noise Emissions from Low-Voltage Electrical and Electronic Equipment in The Range of 9 kHz to 40 GHz".

#### **3.3 Deviations Or Exclusions From The Requirements And Standards**

### **4.0 Test Results**

#### **4.1 Radiated Emissions**

##### **4.1.1 Test Facility**

The test site is an all weather, open field measurement facility defined by an elliptical area of 3258 square meters, which is free of reflective metallic objects and extraneous electromagnetic signals. A non-metallic A-Frame enclosure covers 172 square meters of the ellipse. This enclosure contains a ground level 5-meter diameter turntable, capable of rotating equipment through a complete 360 degrees, and a 3-meter and 10-meter test range with a remotely controlled antenna mast. The floor of the A-Frame and surface of the turntable are covered with a flat metal continuous ground plane. The ground plane extends outside the A-Frame to a distance of 35.6 meters from the center of the turntable. The width of the extension is 2.4 meters.

The ground plane, under the A-Frame enclosure, is covered with protective insulating material. A cellar located beneath the ground level of the A-Frame structure houses personnel and instrumentation for remote control of the antenna mast, the turntable, and other equipment above ground level. The test site complies with the Attenuation Measurements specified in ANSI C63.4 - 1992, and is registered with FCC, VCCI, BSMI, NEMKO and EZU.

For electric field radiated emissions, the EUT and support peripherals or devices required to facilitate EUT operation were positioned either directly on the turntable surface (floor standing equipment) or on a wooden table 80 cm. in height (tabletop equipment), depending on the size



and status of the sample. Hardware not needed in the test field such as remote terminals or non-standard exercisers were placed in the basement below the turntable.

**4.1.2 Radiated Emissions Test Procedure**

**Intentional Radiator Emissions Measurement 9 kHz – 30 MHz**

Testing below 30 MHz was performed with the EUT configured on the test site as above. An H-field measuring antenna was placed at a distance of 30 meters from the EUT at a height of 1 meter above the ground plane. The EUT was rotated 360° in order to obtain a maximum indication on the measuring receiver. This was repeated for each of the three polarizations of the antenna; vertically perpendicular, vertically parallel and horizontal.

**Radiated Emissions 30 MHz – 1000 MHz**

Initial measurements, for the purpose of identifying suspect emissions from the equipment under test, were performed by dividing the test frequency range into the following twenty bands:

Band	Frequency Range	Band	Frequency Range	Band	Frequency Range
1)	30 - 40 MHz	8)	108 - 148 MHz	15)	570 - 670 MHz
2)	40 - 50 MHz	9)	148 - 165 MHz	16)	670 - 770 MHz
3)	50 - 88 MHz	10)	165 - 200 MHz	17)	770 - 855 MHz
4)	88 - 93 MHz	11)	200 - 300 MHz	18)	855 - 875 MHz
5)	93 - 98 MHz	12)	300 - 450 MHz	19)	875 - 892 MHz
6)	98 - 103 MHz	13)	450 - 470 MHz	20)	892 - 1000 MHz
7)	103 - 108 MHz	14)	470 - 570 MHz		

Each of these bands was monitored on a spectrum analyzer display while the turntable was initially positioned at the reference 0 degree point. A mast mounted broadband antenna was located at a distance of 10 meters from the periphery of the EUT(s). The antenna was set to a height of 1 meter, for the vertical polarity and a height of 2.5 meters, for horizontal polarity for these suspect emission scans. All emissions with amplitudes 8 dB or less below the appropriate regulatory limit were identified and saved for later source identification and investigation. This initial suspect identification procedure was repeated for turntable positions of 90, 180 and 270 degrees.

The source of questionable emissions was verified by powering off the EUT(s). Those emissions remaining were removed from the suspect list. Valid suspect emissions were then maximized through cable manipulation. The highest six signals or all within 4 dB of the limit, identified during this initial investigation, were then maximized by rotating the turntable through a complete 360 degrees of azimuth and then raising the antenna from 1 to 4 meters of elevation with the turntable positioned at the angle of maximum signal level. When the EUT(s) azimuth, antenna height and polarization that produced the maximum indication were found, the emission amplitude and frequency were re-measured to obtain maximum peak and quasi-peak field strength. The frequencies and amplitudes of RFI emissions are recorded in this report in units derived as follows:

*Field Strength (dBuV/m) = meter reading (dBuV) + antenna factor (dB/m)+ Cable Loss (dB)*

**Band-edge measurements 13.553 – 13.567 MHz**

Measurement of the frequencies within the 13.553-13.567 MHz band was performed using the “Marker Delta” method suggested by the Federal Communications Commission. The method is described in an E-mail from a representative of the FCC. The e-mail is attached in this report as appendix B.

**4.1.3 Radiated Emissions Test Results (9/16 – 9/19/2003)**

**MEASUREMENT OF THE FUNDAMENTAL**

The electric field emission of the fundamental transmission frequency measured at a distance of 30 meters and compared to the 47 CFR Part 15C, 15.223 limit of 10,000 micro-volts/meter.

Frequency (MHz)	Description	Polarity	Azimuth	Indicated Level (dBuV)	Antenna Factor (dB 1/m)	Cable Loss (dB)	Corrected Level (dBuV/m)	Limit (dBuV/m)	Δ
13.56	Fundamental	Vert ⊥	165	39.07	16.19	0.65	55.91	80	-24.09
		Vert =	158	29.77			45.96		-34.04
		Horiz	162	7.67			23.86		-56.14

**MEASUREMENT OF HARMONICS BELOW 30 MHz**

The electric field emission of the fundamental transmission frequency measured at a distance of 30 meters and compared to the 47 CFR Part 15C, 15.209 limit of 30 micro-volts/meter. No other signals between 9 kHz and 30 MHz were detected.

Frequency (MHz)	Description	Polarity	Azimuth	Indicated Level (dBuV)	Antenna Factor (dB 1/m)	Cable Loss (dB)	Corrected Level (dBuV/m)	Limit (dBuV/m)	Δ
27.12	2nd Harmonic	Vert ⊥	0	2.38	15.67	1.00	19.05	29.54	-10.49
		Vert =	0	2.63			18.30		-11.24
		Horiz	0	-16.12			-0.45		-29.99

**MEASUREMENT OF SPURIOUS EMISSIONS IN THE RANGE 30 MHz - 1000 MHz**

The following table shows the highest amplitude quasi-peak detected field strengths as recorded from the EUT. These measurements, between 30 and 1000 MHz, were made at a distance of 3 meters and compared to the maximum permissible of 47 CFR Part 15C 15.207.

Freq	Pk	Q-Pk	Pol	Angle	Ht	CF	Limit	Delta
[MHz]	[dBuV/m]	[dBuV/m]	H/V	[deg]	[cm]	[dB]	[dBuV/m]	[dB]
189.829	38.68	36.34	H	153	143	11.81	43.5	-7.16
189.829	39.81	37.69	V	264	100	11.81	43.5	-5.81
203.381	38.73	36.83	H	163	143	12.07	43.5	-6.67
203.381	40.79	38.22	V	293	100	12.07	43.5	-5.28
216.945	36.22	35	H	172	116	13.09	46	-11
216.945	38.67	37.21	V	258	100	13.09	46	-8.79
230.504	39.41	37.37	H	124	145	13.85	46	-8.63
230.504	41.39	38.39	V	221	110	13.85	46	-7.61
257.624	45.66	43.6	H	330	118	14.85	46	-2.4
284.747	40.82	38.79	H	144	106	15.95	46	-7.21

**MEASUREMENT OF NON-SPURIOUS EMISSIONS**

Signals not related to the fundamental transmission frequency are listed below. The limit for these signals is the 10-meter, FCC Class A limit.

Freq	Pk	Q-Pk	Pol	Angle	Ht	CF	Limit	Delta
[MHz]	[dBuV/m]	[dBuV/m]	H/V	[deg]	[cm]	[dB]	[dBuV/m]	[dB]
263.235	47.21	45.54	H	355	103	15.14	46	-0.46
300.842	43.4	41.58	H	156	101	16.31	46	-4.42
309.198	44.74	43.45	H	157	100	16.41	46	-2.55
320.001	44.84	41.62	H	152	100	16.54	46	-4.38
401.127	47.29	43.5	H	212	162	18.94	46	-2.5

**Overall Results:** All radiated emissions complied with the requirements of 47 CFR Part15C.

**Band-edge measurements 13.553 – 13.567 MHz**

The measurement of the emissions between 13.553 and 13.567 MHz was not accomplished using the 30 kHz resolution bandwidth suggested by the FCC. The measurement of a band edge 7 kHz from the carrier using a 30 kHz bandwidth, measures more carrier than band edge. The bandwidth was reduced to 9 kHz and the “marker delta” method was used in the following table.

Frequency Span: 27.5 kHz, RBW: 9 kHz, VBW: 10 kHz						
Frequency (MHz)	Peak (dBuV/m)	Delta (dBuV)	Fundamental Quasi-Peak	Adjusted band-edge	15.225 Limit @ 30 M	Margin
13.5530	44.32	9.35	54.21	44.86	50.47	-5.61
13.5593	53.67					
13.5701	44.03	9.64	54.21	44.57	50.47	-5.9

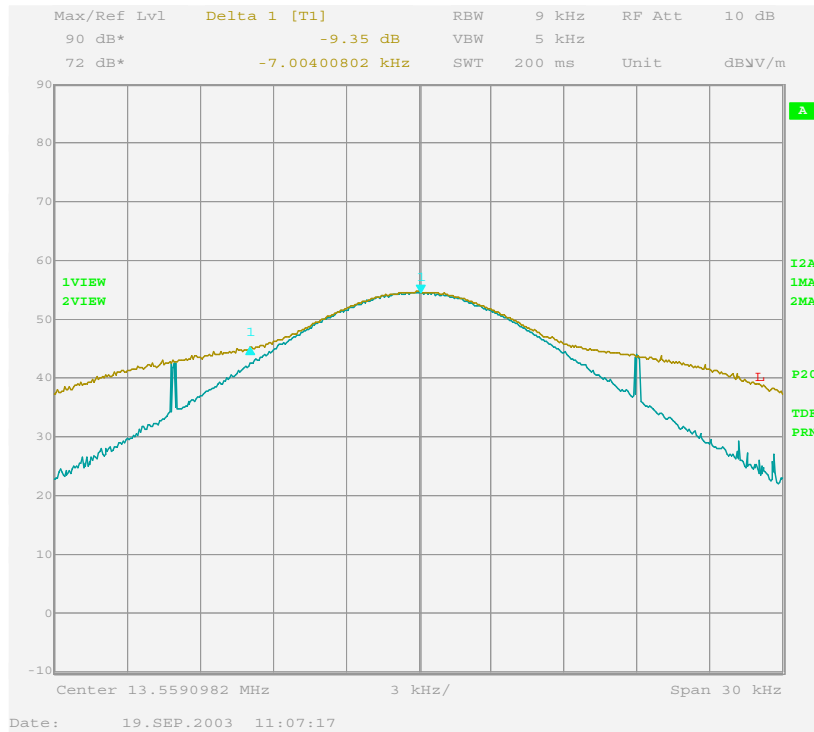

**Spectrum Analyzer display: 13.553 MHz band-edge measurement**

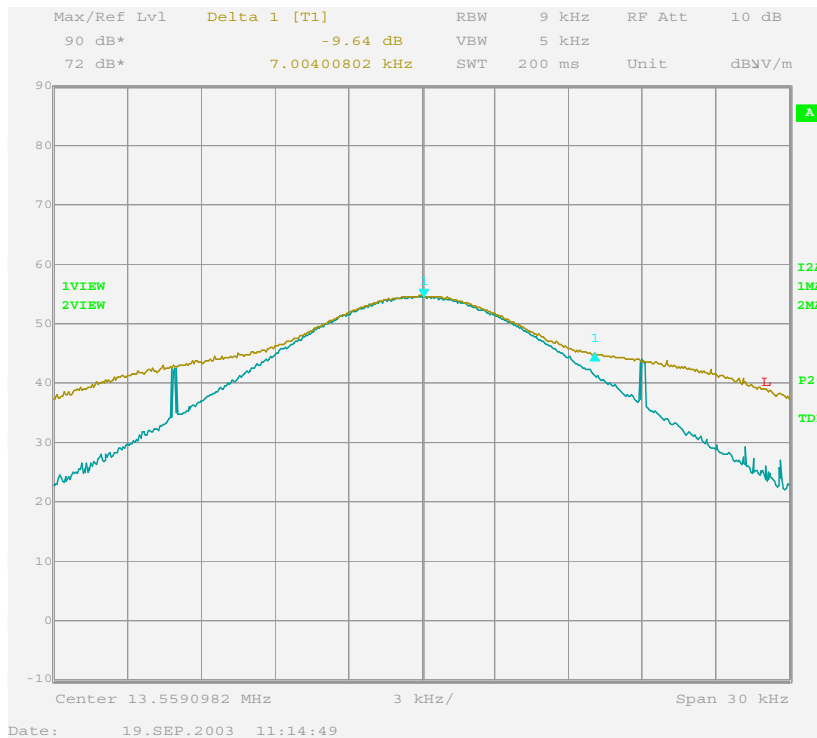

**Spectrum Analyzer display: 13.567 MHz band-edge measurement**

**Test Set-up Photos**

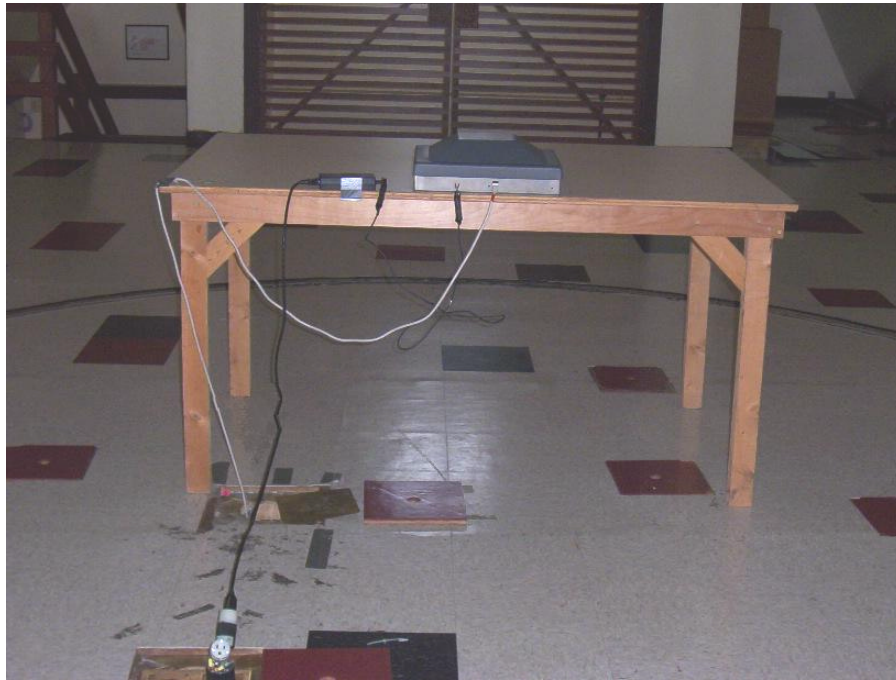

**Radiated Emission Test Setup**

## 4.2 Conducted Emissions

### 4.2.1 Conducted Emission Test Procedure

Peak amplitude terminal voltage emissions at the power line input to the EUT(s) were measured with a spectrum analyzer, using a peak detector and the appropriate CISPR bandwidth, connected to the RF output of a 50 Ohm, 50 micro-henry Line Impedance Stabilization Network (LISN) installed in each power line. Measurements were made over the frequency range from 150 kHz to 30 MHz while the EUT(s) was operating as described in paragraph 2.2.

The amplitudes of emissions measured on the AC power lines of the EUT(s) are recorded in this report in units derived as follows:

$$\text{Peak Emission (dBuV PK)} = \text{Meter reading (dBuV)} + \text{Correction Factor}^*$$

\* Correction Factor = Cable Loss (dB) + LISN factor (dB) + Limiter Loss (dB)

**Note:** For speed and convenience, a spectrum analyzer employing a peak detector was used as the measuring receiver to sweep through and record the spectrum. As a tool to judge compliance of the emissions, the peak detector sweep is displayed and graphed against the appropriate average limit. This type of measurement is valid given that the peak reading will always be greater than or equal to the average or quasi-peak reading. Peak emissions recorded with the spectrum analyzer, that exceed the average limit, or are found to be within 1 dB of the average limit, are re-measured using either a manually tuned receiver with the detector function first set to quasi-peak and then to average, or a spectrum analyzer under remote program control with quasi-peak and average detector functions. These measurements are recorded and presented in the Conducted Emissions Test Results section of this report.

### 4.2.2 Conducted Emissions Test Results (9/22/2003)

The conducted emissions recorded on the EUT AC power cord, displayed against the limits for 47 CFR Part 15C devices are presented on the following pages. Conducted emission amplitudes (dBuV PK) measured with a peak detector are compared with the 15.207 limit for intentional radiators. Where the measured peak detector emission exceeded the average limit, or found to be within 1 dB of average limit, re-measurement using quasi-peak and average detector functions was made. The re-measured emissions are presented in a table next to the appropriate table of peak detector emissions, which displays quasi-peak measurements vs. the quasi-peak limit and the average measurements vs. the average limit.

A termination load of 50 ohms was used instead of the loop antenna normally used by the EUT. This termination load reduced the ambient 13.56 MHz transmitter carrier emission in the shielded enclosure and provided a more accurate evaluation of power supply conducted emissions.

**Deltron 11985A AC Adapter, Neutral Line 120Vac/60Hz**

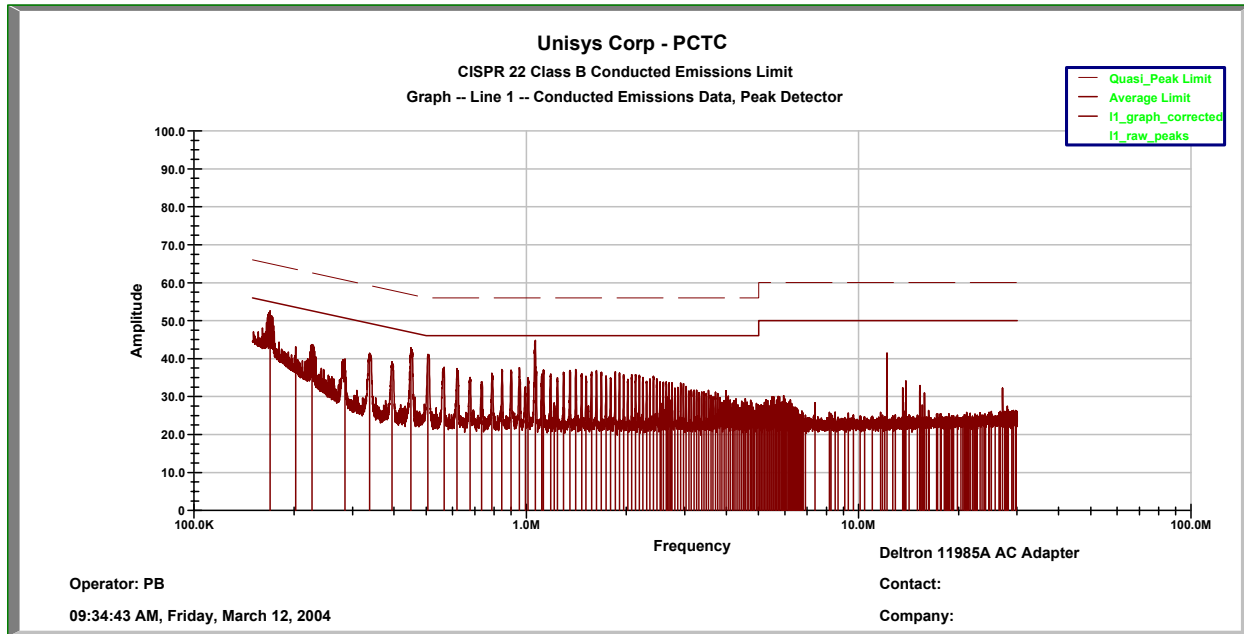

Frequency (Hertz)	Measured Peaks (dbuV)	Average Limit (dBuV)	Margin with Average Limit (dBuV)	Correction Factor (dB)
169,379	52.508	54.991	-2.483	12.808
337,949	41.345	49.254	-7.909	10.645
394,208	39.096	47.975	-8.879	10.596
449,222	42.780	46.889	-4.109	10.580
505,352	41.033	46.000	-4.967	10.533
566,265	37.654	46.000	-8.346	10.454
618,318	37.295	46.000	-8.705	10.395
953,802	37.630	46.000	-8.370	10.230
1,063,440*	44.726	46.000	-1.274	10.226

\*Ambient: Local AM radio station



**Deltron 11985A AC Adapter, Phase Line 120Vac/60Hz**

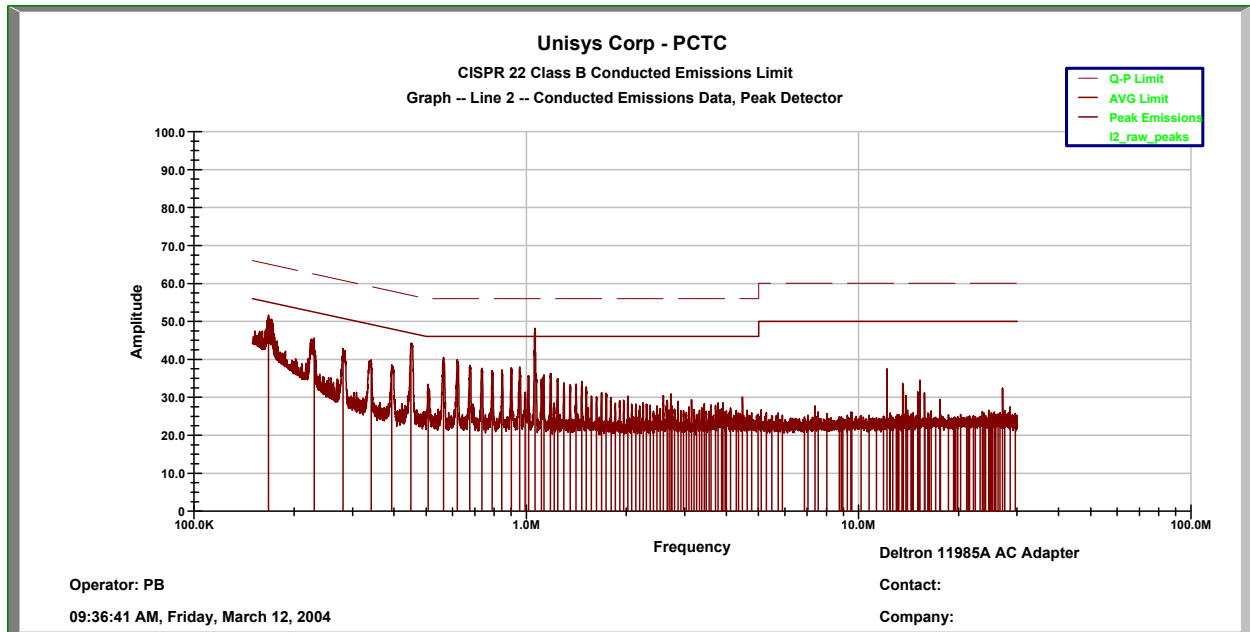

Frequency (Hertz)	Measured Peaks (dbuV)	Average Limit (dBuV)	Margin with Average Limit (dBuV)	Correction Factor (dB)
167,745	51.578	55.071	-3.493	12.878
230,085	45.515	52.447	-6.932	11.115
280,859	42.806	50.790	-7.985	10.706
449,637	44.190	46.882	-2.692	10.590
563,312	40.463	46.000	-5.537	10.463
619,795	39.914	46.000	-6.086	10.414
675,909	38.369	46.000	-7.631	10.369
901,939	37.750	46.000	-8.250	10.250
955,771	37.950	46.000	-8.050	10.250
1,061,470*	48.144	46.000	2.144	10.244

\*Ambient: Local AM radio station

**Overall Results:** The Deltron 11985A AC adapter, connected to the ILS Non-contact Programmer 2.0, complied with the limits of 47 CFR Part 15C.

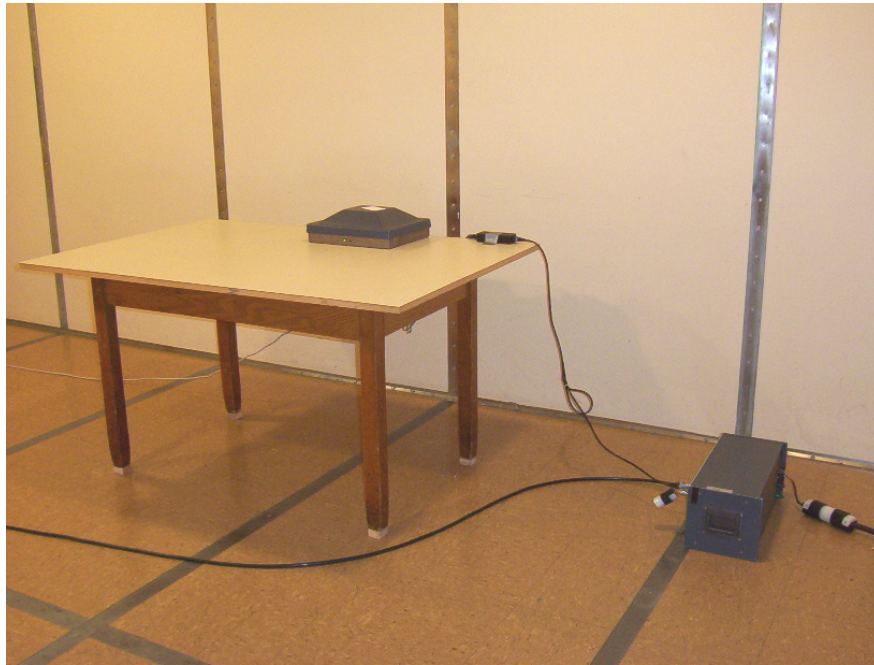

**Test Setup Photos****Photo 2 – Conducted Emissions Test Setup****4.3 Frequency Tolerance Test****4.3.1 Frequency Tolerance Test Procedure**

The EUT was installed in a temperature/humidity chamber. The temperature was reduced to minus 20°C and raised to +50°C. The frequency of the transmitter was measured at the temperature extremes to ensure the .01% tolerance. The AC input voltage to the AC adapter was reduced to 85% of nominal and 115% of nominal. The frequency of the transmitter was again measured at the voltage extremes and compared to the .01% tolerance limit.

**4.3.2 Frequency Tolerance Test Results (10/3/2003)**

Elapsed Time	Temperature	Fundamental Frequency	Frequency Deviation	% Deviation
(minutes)	(°C)	(Hz)	(Hz)	
Begin	23	13.5590930	0.0000000	
5	15	13.5590907	0.0000023	0.0000170
10	7	13.5590895	0.0000035	0.0000258
15	-8	13.5591095	-0.0000165	-0.0001217
18	-10	13.5591245	-0.0000315	-0.0002323
20	-12	13.5591835	-0.0000905	-0.0006674
30	-20	13.5591300	-0.0000370	-0.0002729

Begin	23	13.5590930	0.0000000	
5	29	13.5591077	-0.0000147	-0.0001084
10	35	13.5591185	-0.0000255	-0.0001881
15	40	13.5591085	-0.0000155	-0.0001143
20	45	13.5591890	-0.0000960	-0.0007080
30	50	13.5591245	-0.0000315	-0.0002323
40	50	13.5591005	-0.0000075	-0.0000553

Elapsed Time	Mains Voltage	Frequency	Frequency Deviation	% Deviation
(minutes)	V ac	(Hz)	(Hz)	
Begin	120	13.5590930	0.0000000	
5	102	13.5590927	0.0000003	0.0000022
10	102	13.5590928	0.0000002	0.0000015
15	102	13.5590929	0.0000001	0.0000007

Begin	120	13.5590930	0.0000000	
5	138	13.5590930	0.0000000	0.0000000
10	138	13.5590935	-0.0000005	-0.0000037
15	138	13.5590933	-0.0000003	-0.0000022

**Overall Results:** The ILS Non-contact Programmer 2.0 maintained frequency tolerance less than the .01 % required by 47 CFR Part 15C, 15.225.

**Appendix A – Test Equipment**

<b>Description</b>	<b>Freq Range (Hz)</b>	<b>Model Number</b>	<b>Manufacturer</b>	<b>ID / SN</b>	<b>Last Cal Date</b>
EMI Test Receiver	20 Hz – 26.5 GHz	ESIB 26	Rohde & Schwarz	C232	1/10/03
Antenna, Active Loop	10 k to 30 M	6507	EMCO	D244	11/26/02
Antenna	25M - 2G	LPB-2520/A	ARA	B962	1/28/03
Adapter, Quasi Peak	10k - 1G	85650A	HP	X717	8/8/02 ext. to 10/1/03
Analyzer, Spectrum	100 – 22 G	8566B	HP	Y0313	10/31/02
Analyzer, Spectrum	100Hz - 1.5G	8568B	HP	X718	6/17/03
Controller, Tower and Turntable	NA	2090	EMCO	B812	NA
Display, Analyzer	NA	85662A	HP	X719	6/17/03
Display, Analyzer	NA	OPT 462	HP	Y0314	10/31/02
Filter, Bandpass	0.15M - 30M	NA	Unisys	NA	NA
Limiter, Pulse	DC - 30M	ESH3-Z2	Polarad	NA	NA
LISN	9k - 30M	MN 2053	Chase	U775	8/12/03
Power Supply	NA	5001ix	California Instruments	A-116	10/21/02
Temperature/Humidity Chamber	NA	SM32C	Thermotron	V733	10/24/02

**Appendix B: E-mail from FCC describing band-edge measurements.**

-----Original Message-----

From: GREG.SLEET@checkpt.com [mailto:GREG.SLEET@checkpt.com]  
Sent: Friday, July 25, 2003 5:06 PM  
To: Baumeister, John T.; Mis, Daniel J; Banker, Paul M  
Cc: RONALD.SALESKY@checkpt.com; NIMESH.SHAH@checkpt.com;  
GARY.MAZOKI@checkpt.com; ERIC.ECKSTEIN@checkpt.com  
Subject: Re: Request for measurement guidance for Part 15.225

Gentlemen,

FYI, the attachment and e-mails below from Mr. Joe Dichoso, an OET Engineer with the FCC, gives some guidance when making measurements in Part 15.225. This should help with 13.56 MHz Read/Write approvals testing going forward.

If any further clarification is needed, please follow up directly with Mr. Dichoso with copy to myself and Ron Salesky here at Checkpoint.

Thanks,  
...Greg

Hello Greg,

We have used the same procedure in other Sections other than 15.247 and 15.249. In determining the "Delta" in step two, a lower RBW can be used as long as you can still properly resolve the signal. One method to check for linearity is by adding/removing attenuation. The signal should decrease/increase accordingly.

Regards,  
Joe

>>> GREG.SLEET@checkpt.com 07/23/03 05:32PM >>>

Hi Joe:

Yes, we are trying to determine bandedge compliance of a 13.56 MHz pulsed emission where C63.4 measurement bandwidth is specified to be 9 KHz. Unfortunately, Part 15.225 bandedge is only 7 KHz away from the pulsed emission. (see attached "FCC question.doc" showing C63.4 method)

The "marker delta method" you forwarded was intended for Parts 15.247 or 15.249 using a minimum RBW of 30 KHz. In the case under Part 15.225, this method could be adapted using analyzer settings of RBW=300 Hz with a 3 Second sweep time and max hold to help capture pulsed emissions. (see attached "Spectrograph.pdf" showing adapted method)

What method and settings will the commission support for pulsed emissions under part 15.225?

"Joe Dichoso" <JDICHOSO@fcc.gov>

To: <GREG.SLEET@checkpoint.com>

Subject: Re:Request for measurement  
guidance for Part 15.225

Hello Greg,

Your inquiry was forwarded to me for reply. I am assuming you are trying to determine compliance at or near the bandedge. Please follow the Marker Delta

Method in the attached for determining compliance.

For your information, please be aware of the 15.215(c) which requires that the 20 dB bandwidth fit within the operating band.

(See attached file: Below is a copy of our recommended procedure for measuring band.doc)

(See attached file: FCC question.doc) (See attached file: Spectrograph.pdf)

This message contains information proprietary to Checkpoint Systems Inc. It is intended to be read only by the individual or entity named above or their designee. Any distribution of this message or the information contained herein without written permission from Checkpoint Systems Inc. is strictly prohibited. If the reader of this message is not the intended recipient or an agent responsible for delivering it to the intended recipient, you are hereby notified that you have received this document in error and that any review, dissemination, distribution, or copying of this message is strictly prohibited. If you have received this communication in error, please notify us immediately by e-mail, and delete the original message.

**Attachement: procedure for band-edge measurement using "marker delta" method:**

Below is a copy of our recommended procedure for measuring band-edge emissions from devices operating under 15.249 or 15.247. Band-edge radiated emission measurements may be necessary to demonstrate compliance with radiated emission limits in Sections 15.249(c) or 15.205 when a restricted band is located adjacent to a 15.247 band (e.g., the restricted band beginning at 2483.5 MHz).

In making band-edge measurements, there can be a problem obtaining meaningful data since a measurement instrument that is tuned to a band-edge frequency may also capture some in-band signals when using the resolution bandwidth (RBW) required by measurement procedure ANSI C63.4-1992 (hereafter C63.4). In an effort to compensate for this problem, we have developed the following technique for determining band-edge compliance.

STEP 1) Perform an in-band field strength measurement of the fundamental emission using the RBW and detector function required by C63.4 and our Rules for the frequency being measured. For example, for a device operating in the 902-928 MHz band under Section 15.249, use a 120 kHz RBW with a CISPR QP detector (a peak detector with 100 kHz RBW may alternatively be used). For transmitters operating above 1 GHz, use a 1 MHz RBW and a peak detector (as required by Section 15.35). Repeat the measurement with an average detector (i.e., 1 MHz RBW with 10 Hz video bandwidth). Note: For pulsed emissions, other factors must be included. Please contact us for details if the emission under investigation is pulsed. Also, please note that radiated measurements of the fundamental emission of a transmitter operating under 15.247 are not normally required, but they are necessary in connection with this procedure.

STEP 2) Choose a spectrum analyzer span that encompasses both the peak of the fundamental emission and the band-edge emission under investigation. Set the analyzer RBW to 1% of the total span (but never less than 30 kHz) with a video bandwidth equal to or greater than the RBW. Record the peak levels of the fundamental emission and the relevant band-edge emission (i.e., run several sweeps in peak hold mode). Observe the stored trace and measure the amplitude delta between the peak of the fundamental and the peak of the band-edge emission. This is not a field strength measurement, it is only a relative measurement to determine how much the emission drops at the band-edge relative to the highest fundamental emission level.

STEP 3) Subtract the delta measured in step (2) from the field strengths measured in step (1). The resultant field strengths (CISPR QP, average, or peak, as appropriate) are then used to determine band-edge compliance as required by either 15.249(c) or 15.205.

STEP 4) You can use the above "delta" measurement technique for measuring emissions that are up to two "standard" bandwidths away from the band-edge, where a "standard" bandwidth is the bandwidth specified by C63.4 for the frequency being measured. For example, for band-edge measurements in the restricted band that begins at 2483.5 MHz, C63.4 specifies a measurement bandwidth of at least 1 MHz. Therefore you may use the "delta" technique for measuring emissions up to 2 MHz removed from the band-edge. Radiated emissions that are removed by more than two bandwidths must be measured in the conventional manner.