



## RFID POS READER V2 User's Manual

10092348

Last Updated: April 29, 2014

Revision \*

Checkpoint Systems International GmbH

Brentanostraße 27-29

69434 Hirschhorn

(06272)928-0



Copyright © 2014 by Checkpoint Systems, Inc.  
Released April 29

Published by:

Checkpoint Systems International GmbH.  
Brentanostraße 27-29  
69434 Hirschhorn  
Germany

RFID POS READER V2 Users Manual

Part Number: 10065513

### ***Trademarks***

Checkpoint is a registered trademark of Checkpoint Systems, Inc.

Other product and company names herein may be trademarks of their respective owners.

Other products © or ® their respective manufacturers or copyright holders.

### ***Copyright and Warranty Information***

The information in this guide is subject to change without notice.

Because of the changing nature of this product information presented in the RFID POS READER V2 Reader Users Manual, Checkpoint Systems, Inc. is not liable for any omissions, misstatements, or other errors of information.

The information presented in the Users Manual may not be copied, used or disclosed to others for the purpose of procurement or manufacturing without the written permission of Checkpoint Systems, Inc. This guide and the products discussed in this guide are the exclusive property of Checkpoint Systems Inc. Copyright laws of the United States protects all information and products.

Copyright© 2011 Checkpoint Systems, Inc. All rights reserved.

**Table of contents**

<b>1</b>	<b>REVISION CONTROL</b> .....	<b>4</b>
1.1	REVISION HISTORY .....	4
<b>2</b>	<b>BASIC SAFETY INFORMATION</b> .....	<b>5</b>
2.2	NOTE ABOUT THE DISPOSAL OF OLD UNITS .....	6
<b>3</b>	<b>OPERATING INSTRUCTIONS</b> .....	<b>6</b>
3.1	INTRODUCTION .....	6
3.2	INSTALLATION .....	7
3.3	ACCESSORIES .....	8
3.3.1	Power Supply .....	8
3.3.2	Antennae .....	8
3.4	SETUP FOR TEST AND DEMO .....	9
3.5	BATTERY REPLACEMENT .....	12
<b>4</b>	<b>TECHNICAL DATA</b> .....	<b>13</b>
4.1	MECHANICAL DATA .....	13
4.2	FRONT VIEW .....	14
4.3	REAR VIEW .....	14
4.4	READER SPECIFICATIONS .....	15
4.5	ENVIRONMENT SPECIFICATIONS .....	16
4.6	DIGITAL I/O SPECIFICATION .....	16
4.7	ETHERNET LAN SPECIFICATION .....	17
4.8	RS-232 SPECIFICATIONS .....	17
4.9	USB SPECIFICATION .....	18
<b>5</b>	<b>ORDERING INFORMATION</b> .....	<b>19</b>
<b>6</b>	<b>GLOSSARY</b> .....	<b>19</b>
<b>7</b>	<b>ANNEX DECLARATION OF CONFORMITY</b> .....	<b>20</b>

# 1 Revision Control

## 1.1 Revision History

Content changes to this document from its previous version to the current level are indicated by Microsoft Word track changes bars (|) in the left margin of the document unless a complete rewrite is indicated. Accept all tracked changes to the current document before updating it. This procedure highlights the new changes made to the document by the author thus facilitating efficient review of the document.

Revision #	Revision Date	Change Description and Explanation	Created/Changed By
*	29/04/14		Hans-Günter Meuthen

## 2 Basic safety information



- Read these operating instructions before using the RFID POS READER V2 for the first time! Make yourself completely familiar with the installation and operation of the RFID POS READER V2 ! Retain these operating instructions for later reference.
- The RFID POS READER V2 is used for contact less reading of RFID (Radio Frequency Identification) Tags. Only use the RFID POS READER V2 in the manner described in these operating instructions!
- Note all the detailed safety information given within the individual work steps. All safety information in these operating instructions is identified with the warning symbol shown here.
- Never use the RFID POS READER V2 in areas where there is a danger of explosion.
- Note that the electric installation of RFID POS READER V2 may only be done by a professional.
- It is essential to comply with the electrical, mechanical and climatic specifications given in the Technical Data section. For further information see Chapter Technical data.
- Do not make any changes or modifications to the RFID POS READER V2. If changes or modifications are made, all guarantee claims are voided. Furthermore, the radio approval required for its operation is void!
- Have a faulty RFID POS READER V2 inspected and repaired by our repair center. Never make any repairs yourself under any circumstances.
- Dispose of the RFID POS READER V2 properly after taking out of service. Never put the RFID POS READER V2 into the normal household waste.

### **Federal Communications Commission (FCC) Approval Note:**

This equipment has been tested and found to comply with the limits for a Class A digital device, pursuant to part 15 of the FCC Rules. These limits are designed to provide reasonable protection against harmful interference when the equipment is operated in a commercial environment. This equipment generates, uses, and can radiate radio frequency energy and, if not installed and used in accordance with the instruction manual, may cause harmful interference to radio communications. Operation of this equipment in a residential area is likely to cause harmful interference in which case the user will be required to correct the interference at his own expense.

### **Industry Canada Approval**

This Class A digital apparatus complies with Canadian ICES-003.

Cet appareil numérique de la classe A est conforme à la norme NMB-003 du Canada.

This device complies with Industry Canada licence-exempt RSS standard(s). Operation is subject to the following two conditions: (1) this device may not cause interference, and (2) this device must accept any interference, including interference that may cause undesired operation of the device.

Le présent appareil est conforme aux CNR d'Industrie Canada applicables aux appareils radio exempts de licence. L'exploitation est autorisée aux deux conditions suivantes : (1) l'appareil ne doit pas produire de brouillage, et (2) l'utilisateur de l'appareil doit accepter tout brouillage radioélectrique subi, même si le brouillage est susceptible d'en compromettre le fonctionnement.

## 2.2 Note about the disposal of old units

Within the member countries of the European Union In accordance with the European Union guideline 2002/96/EC, Checkpoint Systems takes back old devices within the member countries of the European Union and disposes of them in an appropriate way. The devices concerned by this are marked with the symbol shown aside.



- For further information on the return procedure, please contact your local sales contact. You will find the addresses of all sales partners in the internet on [www.checkpointsystems.com](http://www.checkpointsystems.com). Please take into consideration also the national implementation of the EU guideline 2002/96/EC of your country.

For all other countries

- Dispose of RFID POS READER V2 properly after taking out of service.
- Observe the regulations valid in your country for the disposal of electronic devices.
- Never put the RFID POS READER V2 into the normal household waste.

## 3 Operating Instructions

### 3.1 Introduction

RFID POS READER V2 is the electronics system of an Ultra High Frequency (UHF) radio frequency identification (RFID) system (typically called an interrogator or reader) which communicates with targets that are applied to or incorporated into an item. The targets (typically referred to as tags or labels) serve to identify the item to which it is attached based on a unique ID stored on the target.



**ATTENTION**



The RFID POS READER V2 antenna ports may be susceptible to damage from static discharge or other high voltage. Use proper Electrostatic Discharge (ESD) precautions to avoid static discharge when handling or making connections to the RFID POS READER V2 antenna or communication ports. Equipment failure can result if the antenna or communication ports are subjected to ESD.

**3.2 Installation**

The RFID POS READER V2 is build in a Point of Sale System, for the installation guidelines refer to the **User Manual MODULAR POINT OF SALE SYSTEM.**

Block Diagram of the Point of Sale System.

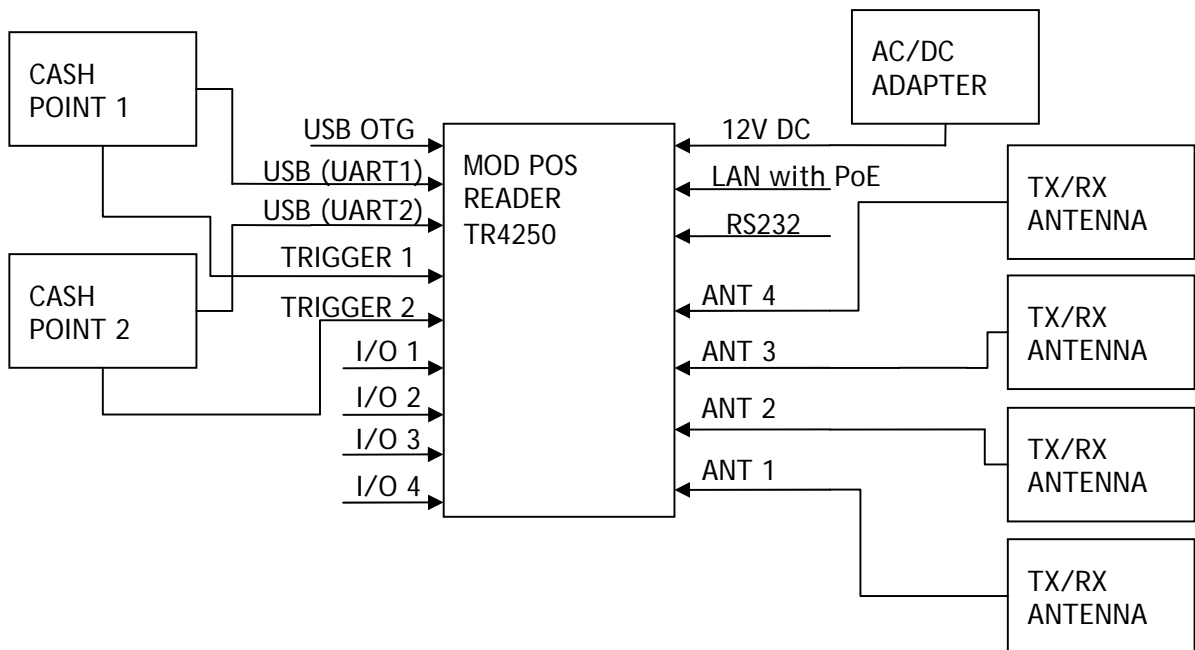

### 3.3 Accessories

#### 3.3.1 Power Supply

The RFID POS READER V2 can be powered either by suitable AC/DC-Adapter or by Power over Ethernet (PoE). When using AC/DC-Adapter, PoE is switched off automatically.

RFID POS READER V2 does not have power switch. If it is necessary to switch off power, simply unplug 12V DC connector or Ethernet Cable in case of PoE.

List of tested AC/DC-Adapter:

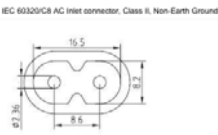
Model	Manufacturer	Description
GT-41082-1812-T2	GlobTek Inc.	 Desktop Version
EPSA120100UE	CUI INC	Wall Plug EU-Version, modified with DC Plug 767K from Switchcraft

List of tested PoE:

Model	Manufacturer	Description
SF100D-08P V2	Cisco	8-way Network Switch
3504G	PowerDsine	8-way Network Switch

#### 3.3.2 Antennae

List of tested antennae:

Model	Manufacturer	Description
10052611	Checkpoint Systems	PoS on Desk RFID only
10049661	Checkpoint Systems	PoS on Desk RFID + RF combined



10034527	Checkpoint Systems	PoS under Desk RFID only
10090241	Checkpoint Systems	PoS under Desk RFID + RF
10045992	Checkpoint Systems	PoS under Desk shielded RFID only
10052028	Checkpoint Systems	PoS on Desk Detacher RFID only
7378457	Checkpoint Systems	PoS under Desk shielded deactivation PAD EU

### 3.4 Setup for Test and Demo

- Set up PC with Checkpoint's Demo Software
- Configure network adapter of PC with suitable IP-Address
- Connect power supply for reader and check if Power LED is on
- Connect antenna to port ANT1
- Put some RFID labels on antenna
- Link RFID POS READER V2 with Ethernet cable to PC
- Start Demo Software

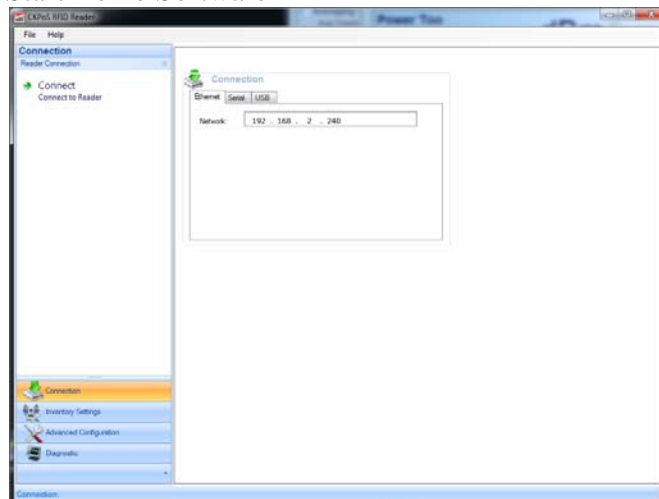

- Connect reader

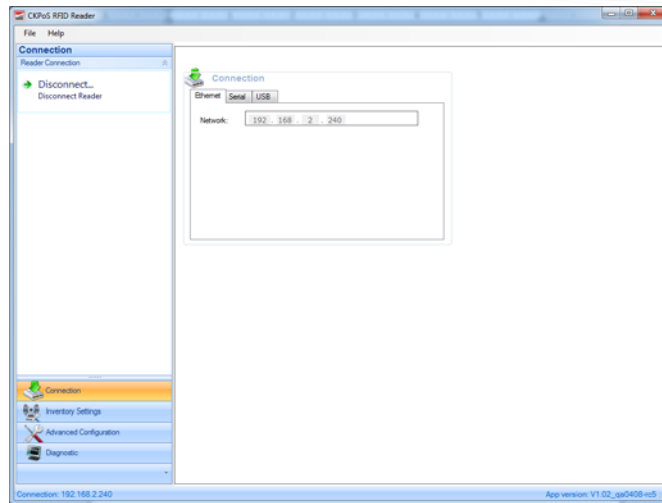

- Select: Inventory Settings

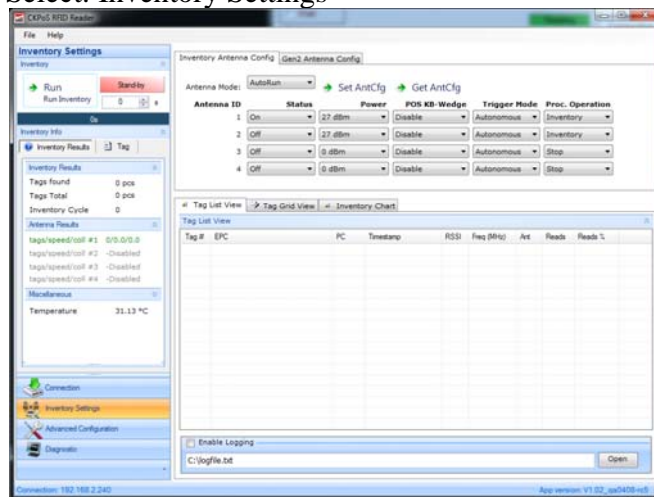

- Configure: Antenna Mode, RF-Power, Trigger Mode, etc.

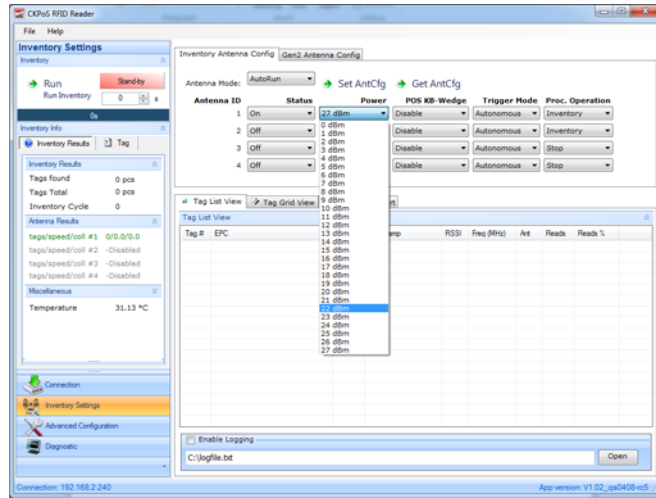

- Configure advanced Gen2 settings and start inventory

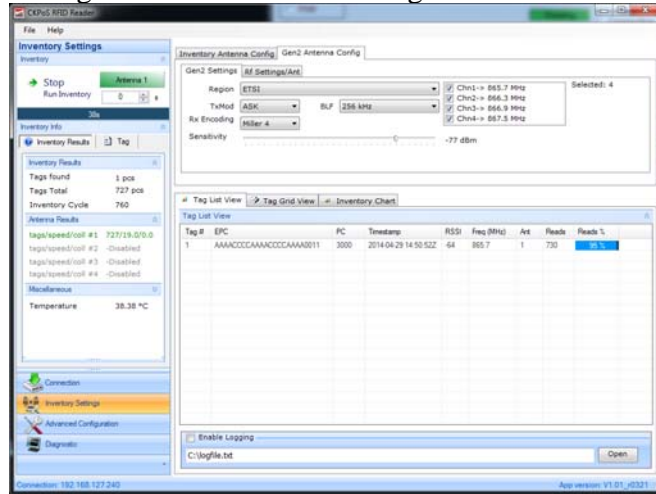

- TAGs in RF-field are listed in Tag List View

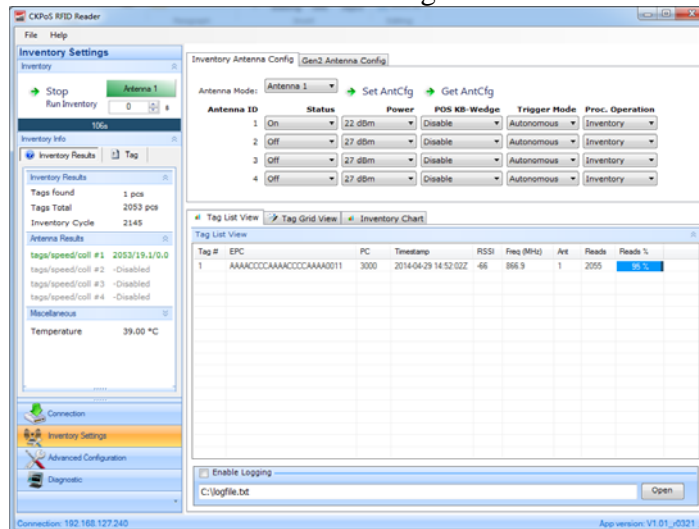

### 3.5 Battery Replacement

Picture shows battery in holder

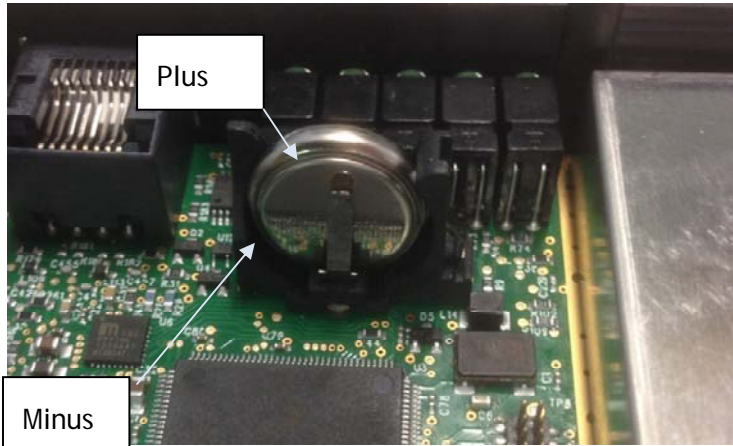

- Battery: Coin Cell CR1632 3V 110mAh
- Before replacing battery measure battery voltage with voltmeter. New battery has 3V. Buffered SRAM and clock work with voltage down to 2V. Replace battery so soon as voltage is down to 2.2V
- Pull out discharged battery and replace it. Take care not to short-circuit Plus and Minus.
- Check battery for right position

List of tested batteries

CR1632	Panasonic	140mAh
CR1632	Energizer	130mAh
CR1632	Renata	125mAh

## 4 Technical Data

### 4.1 Mechanical Data

Size : 7.1 x 4.6 x 1.2 in (180 x 115 x 30 mm)

Weight: 0.7 lbs (320g)

Case material Plastic

Color Black

#### Connectors

Ethernet with PoE\* RJ45 8pin \*PoE Power over Ethernet

RS232 RJ45 8pin

DC-Input Barrel Type, 2.1/5.5/12.1 mm, center pin +

I/O Connector 4 x RJ12 6pin

Digital Inputs 2 x RJ12 6pin

USB1 OTG Micro AB 5pin

USB2 – USB3 Type B 4pin

ANT 1 – ANT 4 SMA-female

## 4.2 Front view

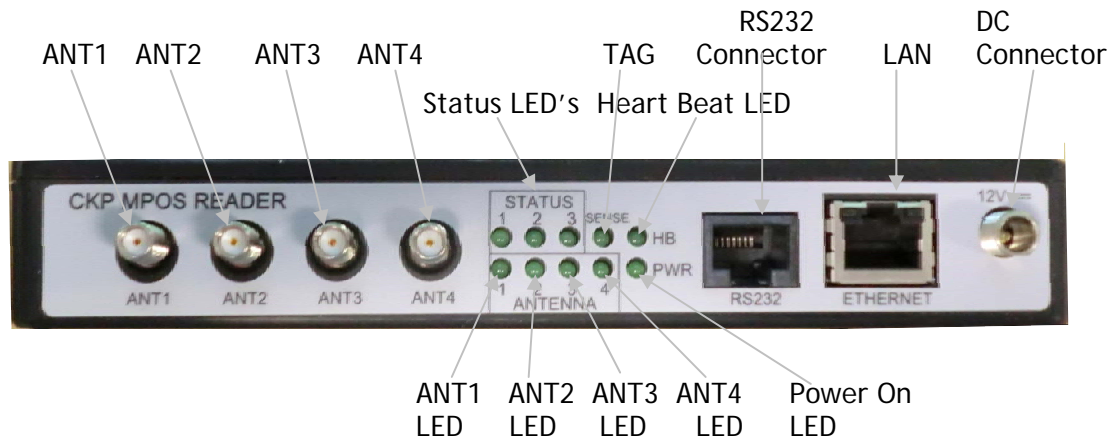

## 4.3 Rear view

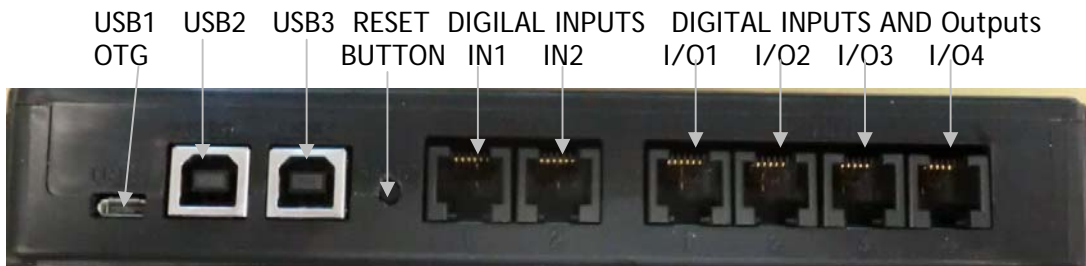

## 4.4 Reader Specifications

### Power Connection

Input Voltage	12 VDC, Minimum 10V, Maximum 24V
Input current	0.75 A at 12 VDC
Power Consumption	3W ( typical while idle)
	6 W ( typical at 500 mW conducted RF output power)
	9 W ( Maximum with USB-Device and Digital Outputs powered )

### Power over Ethernet (PoE)

IEEE class 802.3af 12.95W, LAN connector RJ45

### RF Specifications

Frequency Range	865-868 MHz 902-928 MHz
RF Output Power max	500 mW conducted (27 dBm)
RF Output Power adjustment range	2 mW - 500 mW conducted (3 - 27 dBm) in 1dB steps
RF Output Power settings accuracy	+ - 1dB

### RF Connections

RF Outputs	4
Impedance	50 Ohm



**Caution:** *This device has been designed to operate with no more than 1 Watt into the antenna and an antenna gain of no more than 6 dBic. Antenna having a higher gain is strictly prohibited per regulations of Industry Canada, unless power into the antenna is decreased to compensate for the increased antenna gain. The required antenna impedance is 50 ohms.*

*To reduce potential radio interference to other users, the antenna type and its gain should be so chosen that the equivalent isotropic radiated power (EIRP) is not more than that required for successful communication.*

*The installer of this radio equipment must ensure that the antenna is located or pointed such that it does not emit an RF field in excess of Health Canada limits for the general population; consult Safety Code 6, obtainable from Health Canada's website at [www.hc-sc.gc.ca](http://www.hc-sc.gc.ca)*

## 4.5 Environment Specifications

Operating temperature	23°F to 113°F ( -5°C to 45°C )
Storage temperature	- 40°F to 158°F ( -40°C to 70°C )
Relative Humidity	5% to 95 % non-condensing

## 4.6 Digital I/O Specification

### Cash Point Trigger (dual)

Connector RJ12 6P

2 Input 5 VDC, 1 mA Minimum 3V, Maximum 8V

Signals	Pin 1	+5VDC
	Pin 2	free
	Pin 3	Digital IN
	Pin 4	Digital IN
	Pin 5	free
	Pin 6	GND

### LEDs & Buzzer (quad)

Connector RJ12 6P

1 Input 5 VDC, 1 mA

3 Outputs Open Collector (3 to 5 V, 20 mA Max)

Signals	Pin 1	+5VDC
	Pin 2	Digital OUT
	Pin 3	Digital OUT
	Pin 4	Digital OUT
	Pin 5	Digital IN
	Pin 6	GND



## 4.7 Ethernet LAN Specification

Connector	RJ-45
Ethernet	10/100 BaseT
Indicators	Yellow      Indicates link is operational
	Green        Indicates network traffic detected.
Signals	Pin 1        TXD+ (Transmit Data +)
	Pin 2        TXD- (Transmit Data -)
	Pin 3        RXD+ (Receive Data +)
	Pin 4        POE (Power over Ethernet)
	Pin 5        POE (Power over Ethernet)
	Pin 6        RXD- (Receive Data -)
	Pin 7        POE (Power over Ethernet)
	Pin 8        POE (Power over Ethernet)

## 4.8 RS-232 Specifications

Connector	RJ45
Baud rate	600 - 115200 (Default = 115200)
Parity	None
Data bits	8
Stop bits	1
Signals	Pin 1        RXD
	Pin 2        TXD
	Pin 3        GND
	Pin 4        +3.3V
	Pin 5        GND
	Pin 6        Local Alarm Disable (Low active)
	Pin 7        Reset (High active)
	Pin 8        Global Alarm Disable (Low active)

## 4.9 USB Specification

### USB UART Converter (dual)

Connector	Female USB Type B	
Signals	Pin 1	VCC (+5V)
	Pin 2	- DATA
	Pin 3	+ DATA
	Pin 4	GND

### USB OTG

Connector	Female USB Type Micro AB	
Signals	Pin 1	VCC (+5V max 500mA)
	Pin 2	- DATA
	Pin 3	+ DATA
	Pin 4	Identifier Pin
	Pin 5	GND

## 5 Ordering Information

The UHF-RFID Reader is available with the following number

Order Number: 10112394 RFID POS READER V2

## 6 Glossary

**RFID** Radio Frequency Identification.

**EPC** Electronic Product Code, a unique item identification number

**EPC Global** A new global standard that combines RFID technology, existing communications network infrastructure and the Electronic Product Code to enable immediate and automatic identification and tracking of an item through the whole supply chain globally, resulting in improved efficiency and visibility of the supply chain

## 7 Annex Declaration of Conformity

### EMC limits and radio approvals

EMV for Short Range Device ETSI EN 301 489-3

Safety of equipment of low voltage device EN 60950-1

Approval for UHF RFID READER; Europe ETSI EN 302 208-1

Approval for Short Range Device; USA FCC 47 CFR Part 15

Approval for Short Range Device; Canada RSS 210 Issue 7

<b>DECLARATION OF CONFORMITY</b> Directive 99/5/EC (R&TTED)	
Manufacturer or Authorized representative:	<b>Checkpoint Systems International GmbH</b>
Address:	<b>Brentanostraße 27 – 29</b> <b>69434 Hirschhorn/N.</b>
We declare on our sole responsibility, that the following product:	
<b>Kind of equipment:</b>	<b>Radio Frequency Identification System (RFID)</b>
<b>Type-designation:</b>	<b>RFID POS Reader V2</b>
is in compliance with the essential requirements of §3 of the R&TTED.	
- Health and safety requirements pursuant to §3(1)a: Applied Standard(s) or other means of providing conformity: <b>EN 60950-1 : 2006 (2<sup>nd</sup> Edition) + A12: 2011</b> <b>EN 50364 : 2010</b> <b>EN 62369-1 : 2009</b>	
- Protection requirements concerning EMC §3(1)b: Applied Standard(s) or other means of providing conformity: <b>EN 301 489-1 V1.9.2 : 2011</b> <b>EN 301 489-3 V1.6.1 : 2013</b>	
- Measures for the efficient use of the radio frequency spectrum §3(2) Applied Standard(s) or other means of providing conformity: <b>EN 302 208 – 2 (V1.3.1) : 02/2010 (RFID)</b> <b>EN 302 208 – 1 (V1.3.1) : 02/2010 (RFID)</b>	
<b>Hirschhorn, 10. April 2014</b>	 Checkpoint Systems International GmbH Ersheimer Str. 69 + D-69434 Hirschhorn/N. <i>P.P.a.</i>  <b>Peter Bremer</b> Senior Director R&D Europe
Place and date of issue	
<b>Accredited test laboratory:</b>	<b>CSA Group Bayern GmbH, Ohmstrasse 1-4</b> 94342 Strasskirchen, Germany