

TEST REPORT

CERTIFICATE OF CONFORMITY

Standard: 47 CFR FCC Part 15, Subpart E (Section 15.407)

Report No.: RFCDFY-WTW-P23020154-1

FCC ID: DMOTCBARM

Product: TeamConnect Bar

Brand: SENNHEISER

Model No.: TC Bar M

Received Date: 2023/2/6

Test Date: 2023/2/14 ~ 2023/3/16

Issued Date: 2023/6/2

Applicant: Sennheiser Electronic Corp

Address: 1 Enterprise Drive Old Lyme, Connecticut 06371 United States

Issued By: Bureau Veritas Consumer Products Services (H.K.) Ltd., Taoyuan Branch
Lin Kou Laboratories

Lab Address: No. 47-2, 14th Ling, Chia Pau Vil., Lin Kou Dist., New Taipei City, Taiwan

Test Location: No. 47-2, 14th Ling, Chia Pau Vil., Lin Kou Dist., New Taipei City, Taiwan

FCC Registration / 198487 / TW2021

Designation Number:

Approved by: Jeremy Lin, **Date:** 2023/6/2
Jeremy Lin / Project Engineer

This test report consists of 107 pages in total. It may be duplicated completely for legal use with the approval of the applicant. It should not be reproduced except in full, without the written approval of our laboratory. The test results in the report only apply to the tested sample. The test results in this report are traceable to the national or international standards.



Prepared by : Annie Chang / Senior Specialist

This report is governed by, and incorporates by reference, the Conditions of Testing as posted at the date of issuance of this report at <http://www.bureauveritas.com/home/about-us/our-business/cps/about-us/terms-conditions/> and is intended for your exclusive use. Any copying or replication of this report to or for any other person or entity, or use of our name or trademark, is permitted only with our prior written permission. This report sets forth our findings solely with respect to the test samples identified herein. The results set forth in this report are not indicative or representative of the quality or characteristics of the lot from which a test sample was taken or any similar or identical product unless specifically and expressly noted. Our report includes all of the tests requested by you and the results thereof based upon the information that you provided to us. Measurement uncertainty is only provided upon request for accredited tests. Statements of conformity are based on simple acceptance criteria without taking measurement uncertainty into account, unless otherwise requested in writing. You have 60 days from date of issuance of this report to notify us of any material error or omission caused by our negligence or if you require measurement uncertainty; provided, however, that such notice shall be in writing and shall specifically address the issue you wish to raise. A failure to raise such issue within the prescribed time shall constitute your unqualified acceptance of the completeness of this report, the tests conducted and the correctness of the report contents.

Table of Contents

Release Control Record	4
1 Certificate	5
2 Summary of Test Results	6
2.1 Measurement Uncertainty	6
2.2 Supplementary Information	6
3 General Information	7
3.1 General Description of EUT	7
3.2 Antenna Description of EUT	8
3.3 Channel List	9
3.4 Test Mode Applicability and Tested Channel Detail	11
3.5 Duty Cycle of Test Signal	13
3.6 Test Program Used and Operation Descriptions	15
3.7 Connection Diagram of EUT and Peripheral Devices	15
3.8 Configuration of Peripheral Devices and Cable Connections	16
4 Test Instruments	17
4.1 26 dB Bandwidth	17
4.2 RF Output Power	17
4.3 Power Spectral Density	17
4.4 6 dB Bandwidth	17
4.5 Occupied Bandwidth	17
4.6 Frequency Stability	17
4.7 AC Power Conducted Emissions	18
4.8 Unwanted Emissions below 1 GHz	19
4.9 Unwanted Emissions above 1 GHz	20
5 Limits of Test Items	21
5.1 26 dB Bandwidth	21
5.2 RF Output Power	21
5.3 Power Spectral Density	21
5.4 6 dB Bandwidth	21
5.5 Occupied Bandwidth	21
5.6 Frequency Stability	21
5.7 AC Power Conducted Emissions	22
5.8 Unwanted Emissions below 1 GHz	22
5.9 Unwanted Emissions above 1 GHz	23
6 Test Arrangements	24
6.1 26 dB Bandwidth	24
6.1.1 Test Setup	24
6.1.2 Test Procedure	24
6.2 RF Output Power	24
6.2.1 Test Setup	24
6.2.2 Test Procedure	24
6.3 Power Spectral Density	24
6.3.1 Test Setup	24
6.3.2 Test Procedure	24
6.4 6 dB Bandwidth	26
6.4.1 Test Setup	26
6.4.2 Test Procedure	26
6.5 Occupied Bandwidth	26
6.5.1 Test Setup	26
6.5.2 Test Procedure	26
6.6 Frequency Stability	27
6.6.1 Test Setup	27
6.6.2 Test Procedure	27
6.7 AC Power Conducted Emissions	28



6.7.1	Test Setup	28
6.7.2	Test Procedure	28
6.8	Unwanted Emissions below 1 GHz	29
6.8.1	Test Setup	29
6.8.2	Test Procedure	30
6.9	Unwanted Emissions above 1 GHz	31
6.9.1	Test Setup	31
6.9.2	Test Procedure	31
7	Test Results of Test Item	32
7.1	26 dB Bandwidth	32
7.2	RF Output Power	35
7.3	Power Spectral Density	38
7.4	6 dB Bandwidth	42
7.5	Occupied Bandwidth	44
7.6	Frequency Stability	49
7.7	AC Power Conducted Emissions	50
7.8	Unwanted Emissions below 1 GHz	52
7.9	Unwanted Emissions above 1 GHz	54
8	Pictures of Test Arrangements	106
9	Information of the Testing Laboratories	107



Release Control Record

Issue No.	Description	Date Issued
RFCDFY-WTW-P23020154-1	Original release.	2023/6/2

1 Certificate

Product: TeamConnect Bar

Brand: SENNHEISER

Test Model: TC Bar M

Sample Status: Engineering sample

Hardware version: DVT1.1 sample

Software version: V.0.8.6

Serial number: Conducted: 0482000171; Radiated: 0502000193

Applicant: Sennheiser Electronic Corp

Test Date: 2023/2/14 ~ 2023/3/16

Standard: 47 CFR FCC Part 15, Subpart E (Section 15.407)

Measurement ANSI C63.10-2013

procedure: KDB 789033 D02 General UNII Test Procedure New Rules v02r01

The above equipment has been tested by **Bureau Veritas Consumer Products Services (H.K.) Ltd., Taoyuan Branch**, and found compliance with the requirement of the above standards. The test record, data evaluation & Equipment Under Test (EUT) configurations represented herein are true and accurate accounts of the measurements of the sample's RF characteristics under the conditions specified in this report.

2 Summary of Test Results

47 CFR FCC Part 15, Subpart E (Section 15.407)			
Clause	Test Item	Result	Remark
15.407(a)(2)	26 dB Bandwidth	Pass	For U-NII-2A U-NII-2C Band output power limitation is determined based on 26dBc bandwidth.
15.407(a)(1) 15.407(a)(2) 15.407(a)(3)	RF Output Power	Pass	Meet the requirement of limit.
15.407(a)(1) 15.407(a)(2) 15.407(a)(3)	Power Spectral Density	Pass	Meet the requirement of limit.
15.407(e)	6 dB Bandwidth	Pass	Meet the requirement of limit. (U-NII-3 Band only)
---	Occupied Bandwidth	-	Reference only.
15.407(g)	Frequency Stability	Pass	Meet the requirement of limit.
15.407(b)(9)	AC Power Conducted Emissions	Pass	Minimum passing margin is -16.59 dB at 15.90611 MHz
15.407(b)(9)	Unwanted Emissions below 1 GHz	Pass	Minimum passing margin is -5.0 dB at 165.02 MHz
15.407(b) (1/10) 15.407(b) (2/10) 15.407(b) (3/10) 15.407(b) (4(i)/10)	Unwanted Emissions above 1 GHz	Pass	Minimum passing margin is -3.2 dB at 5150.00, 5470.00 MHz
15.203	Antenna Requirement	Pass	No antenna connector is used.

Note: Determining compliance based on the results of the compliance measurement, not taking into account measurement instrumentation uncertainty.

2.1 Measurement Uncertainty

Where relevant, the following measurement uncertainty levels have been estimated for tests performed on the EUT as specified in CISPR 16-4-2:

Measurement	Specification	Expanded Uncertainty (k=2) (±)
AC Power Conducted Emissions	150 kHz ~ 30 MHz	3.00 dB
Unwanted Emissions below 1 GHz	9 kHz ~ 30 MHz	2.38 dB
	30 MHz ~ 1 GHz	5.7 dB
Unwanted Emissions above 1 GHz	1 GHz ~ 6 GHz	4.83 dB
	6 GHz ~ 18 GHz	5.37 dB
	18 GHz ~ 40 GHz	5.24 dB

The other instruments specified are routine verified to remain within the calibrated levels, no measurement uncertainty is required to be calculated.

2.2 Supplementary Information

There is not any deviation from the test standards for the test method, and no modifications required for compliance.

3 General Information

3.1 General Description of EUT

Product	TeamConnect Bar
Brand	SENNHEISER
Test Model	TC Bar M
Status of EUT	Engineering sample
Hardware version	DVT1.1 sample
Software version	V.0.8.6
Serial number	Conducted: 0482000171; Radiated: 0502000193
Power Supply Rating	18Vdc from adapter
Modulation Type	CCK, DQPSK, DBPSK for DSSS 64QAM, 16QAM, QPSK, BPSK for OFDM 256QAM for OFDM in VHT mode
Modulation Technology	DSSS, OFDM
Transfer Rate	Up to 433.3Mbps
Operating Frequency	5.18 ~ 5.24 GHz, 5.26 ~ 5.32 GHz, 5.5 ~ 5.7 GHz, 5.745 ~ 5.825 GHz
Number of Channel	802.11a, 802.11n (HT20), 802.11ac (VHT20):24 802.11n (HT40), 802.11ac (VHT40):11 802.11ac (VHT80):5
Output Power	5.18 GHz ~ 5.24 GHz : 35.727 mW (15.53 dBm) 5.26 GHz ~ 5.32 GHz : 36.058 mW (15.57 dBm) 5.5 GHz ~ 5.7 GHz : 37.068 mW (15.69 dBm) 5.745 GHz ~ 5.825 GHz : 35.645 mW (15.52 dBm)
EUT Category	Client device

Note:

1. There are Bluetooth and WLAN (2.4 GHz & 5 GHz) technology used for the EUT.
2. WLAN 2.4 GHz & WLAN 5 GHz & Bluetooth technology cannot transmit at same time.
3. The EUT uses following adapter.

Item	Brand	Model	Rating
Adapter	SENNHEISER	E096-1A180500B3	AC I/P: 100-240Vac, 50/6Hz, 1.5A DC O/P: 18Vdc, 5A, 90.0W AC 3-Pin, Non-shielded DC cable (1.8m)

4. The EUT has following accessories:

Item	Specification
USB A to C cable	Shielded 2.9m
HDMI cable	Shielded 1.5m
Remote	-

5. PCB information is as follows.

PCB name	TYM part NO.	PCB version
QCS610_SOM_Board	T651000018350	SEP.06.2022
TC BAR M ETH IO	T651000017350	OCT.06.2022
TC-BAR M_HDMI IO	T651000017360	OCT.06.2022
TC-BAR M LED+Button	T651000017380	2022.JUL.05
TC-BAR M_Light-Bar	T651000017390	OCT.03.2022
TC-BAR M MAIN	T651000017400	OCT.07.2022
TC-BAR M_Mic Array + IrDA	T651000017340	SEP.29.2022

6. The EUT doesn't support OFDMA and Partial RU mode.
7. The above EUT information is declared by manufacturer and for more detailed features description, please refers to the manufacturer's specifications or user's manual.

3.2 Antenna Description of EUT

1. The antenna information is listed as below.

Frequency Band (MHz)	Gain (dBi)		Antenna Type	Connector Type
	Max.	Min.		
2400~2480	4.30	3.25	PIFA	ipex(MHF)
5175~5225	3.97	3.70		
5250~5350	3.72	3.33		
5725~5470	4.54	3.31		
5725~5825	4.54	3.88		

* Detail antenna specification please refer to antenna datasheet and/or antenna measurement report.

2. The EUT incorporates a SISO function:

5 GHz Band		
Modulation Mode	TX & RX Configuration	
802.11a	1TX	1RX
802.11n (HT20)	1TX	1RX
802.11n (HT40)	1TX	1RX
802.11ac (VHT20)	1TX	1RX
802.11ac (VHT40)	1TX	1RX
802.11ac (VHT80)	1TX	1RX

Note: The modulation and bandwidth are similar for 802.11n mode for 20 MHz (40 MHz) and 802.11ac mode for 20 MHz (40 MHz), therefore investigated worst case to representative mode in test report.

3.3 Channel List

FOR 5180 ~ 5320 MHz

8 channels are provided for 802.11a, 802.11n (HT20), 802.11ac (VHT20):

Channel	Frequency	Channel	Frequency
36	5180 MHz	52	5260 MHz
40	5200 MHz	56	5280 MHz
44	5220 MHz	60	5300 MHz
48	5240 MHz	64	5320 MHz

4 channels are provided for 802.11n (HT40), 802.11ac (VHT40):

Channel	Frequency	Channel	Frequency
38	5190 MHz	54	5270 MHz
46	5230 MHz	62	5310 MHz

2 channels are provided for 802.11ac (VHT80):

Channel	Frequency	Channel	Frequency
42	5210 MHz	58	5290 MHz

FOR 5500 ~ 5700 MHz

11 channels are provided for 802.11a, 802.11n (HT20), 802.11ac (VHT20):

Channel	Frequency	Channel	Frequency
100	5500 MHz	124	5620 MHz
104	5520 MHz	128	5640 MHz
108	5540 MHz	132	5660 MHz
112	5560 MHz	136	5680 MHz
116	5580 MHz	140	5700 MHz
120	5600 MHz		

5 channels are provided for 802.11n (HT40), 802.11ac (VHT40):

Channel	Frequency	Channel	Frequency
102	5510 MHz	126	5630 MHz
110	5550 MHz	134	5670 MHz
118	5590 MHz		

2 channels are provided for 802.11ac (VHT80):

Channel	Frequency	Channel	Frequency
106	5530 MHz	122	5610 MHz

FOR 5745 ~ 5825 MHz:

5 channels are provided for 802.11a, 802.11n (HT20), 802.11ac (VHT20):

Channel	Frequency	Channel	Frequency
149	5745 MHz	161	5805 MHz
153	5765 MHz	165	5825 MHz
157	5785 MHz		

2 channels are provided for 802.11n (HT40), 802.11ac (VHT40):

Channel	Frequency	Channel	Frequency
151	5755 MHz	159	5795 MHz

1 channel is provided for 802.11ac (VHT80):

Channel	Frequency
155	5775 MHz

3.4 Test Mode Applicability and Tested Channel Detail

Pre-Scan:	1. EUT can be used in the following ways: XYZ 3-axis. Pre-scan in these ways and find the worst case as a representative test condition.
Worst Case:	1. X/ Y/ Z Worst Condition: X Axis for Unwanted Emission above 1GHz and Unwanted Emission below 1GHz.

Following channel(s) was (were) selected for the final test as listed below:

Test Item	Mode	Signal Mode	Tested Channel	Modulation	Data Rate Parameter
26 dB Bandwidth	802.11a	CDD	52, 60, 64, 100, 116, 140	BPSK	6Mb/s
	802.11ac (VHT20)	CDD	52, 60, 64, 100, 116, 140	BPSK	MCS0
	802.11ac (VHT40)	CDD	54, 62, 102, 110, 134	BPSK	MCS0
	802.11ac (VHT80)	CDD	58, 106, 122	BPSK	MCS0
RF Output Power / Power Spectral Density	802.11a	CDD	36, 40, 48, 52, 60, 64, 100, 116, 140, 149, 157, 165	BPSK	6Mb/s
	802.11ac (VHT20)	CDD	36, 40, 48, 52, 60, 64, 100, 116, 140, 149, 157, 165	BPSK	MCS0
	802.11ac (VHT40)	CDD	38, 46, 54, 62, 102, 110, 134, 151, 159	BPSK	MCS0
	802.11ac (VHT80)	CDD	42, 58, 106, 122, 155	BPSK	MCS0
6 dB Bandwidth	802.11a	CDD	149, 157, 165	BPSK	6Mb/s
	802.11ac (VHT20)	CDD	149, 157, 165	BPSK	MCS0
	802.11ac (VHT40)	CDD	151, 159	BPSK	MCS0
	802.11ac (VHT80)	CDD	155	BPSK	MCS0
Occupied Bandwidth	802.11a	CDD	36, 40, 48, 52, 60, 64, 100, 116, 140, 149, 157, 165	BPSK	6Mb/s
	802.11ac (VHT20)	CDD	36, 40, 48, 52, 60, 64, 100, 116, 140, 149, 157, 165	BPSK	MCS0
	802.11ac (VHT40)	CDD	38, 46, 54, 62, 102, 110, 134, 151, 159	BPSK	MCS0
	802.11ac (VHT80)	CDD	42, 58, 106, 122, 155	BPSK	MCS0
Frequency Stability	802.11a	-	36	unmodulated	-
AC Power Conducted Emissions	802.11ac (VHT20)	CDD	100	BPSK	MCS0
Unwanted Emissions below 1 GHz	802.11ac (VHT20)	CDD	100	BPSK	MCS0



Test Item	Mode	Signal Mode	Tested Channel	Modulation	Data Rate Parameter
Unwanted Emissions above 1 GHz	802.11a	CDD	36, 40, 48, 52, 60, 64, 100, 116, 140, 149, 157, 165	BPSK	6Mb/s
	802.11ac (VHT20)	CDD	36, 40, 48, 52, 60, 64, 100, 116, 140, 149, 157, 165	BPSK	MCS0
	802.11ac (VHT40)	CDD	38, 46, 54, 62, 102, 110, 134, 151, 159	BPSK	MCS0
	802.11ac (VHT80)	CDD	42, 58, 106, 122, 155	BPSK	MCS0



3.5 Duty Cycle of Test Signal

802.11a: Duty cycle = 2.028 ms / 2.064 ms x 100% = 98.3%

802.11ac (VHT20): Duty cycle = 1.901 ms / 1.936 ms x 100% = 98.2%

802.11ac (VHT40): Duty cycle = 0.937 ms / 0.97 ms x 100% = 96.6%, duty factor = 10 * log (1/Duty cycle) = 0.15 dB

802.11ac (VHT80): Duty cycle = 0.463 ms / 0.494 ms x 100% = 93.7%, duty factor = 10 * log (1/Duty cycle) = 0.28 dB

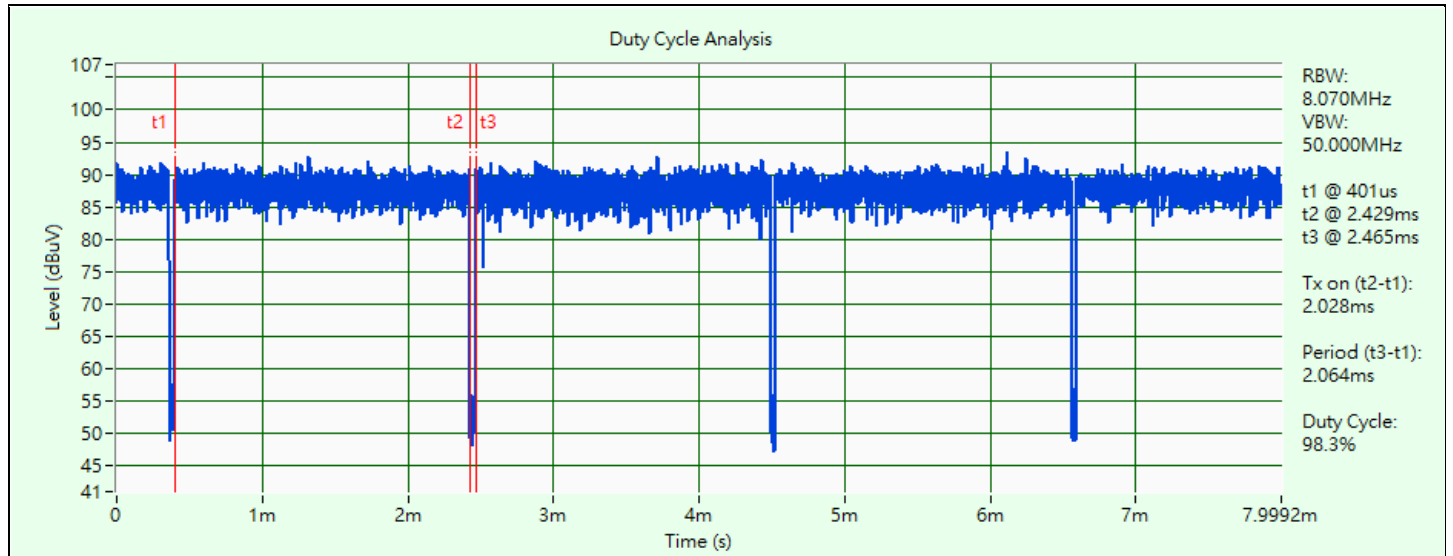

802.11a

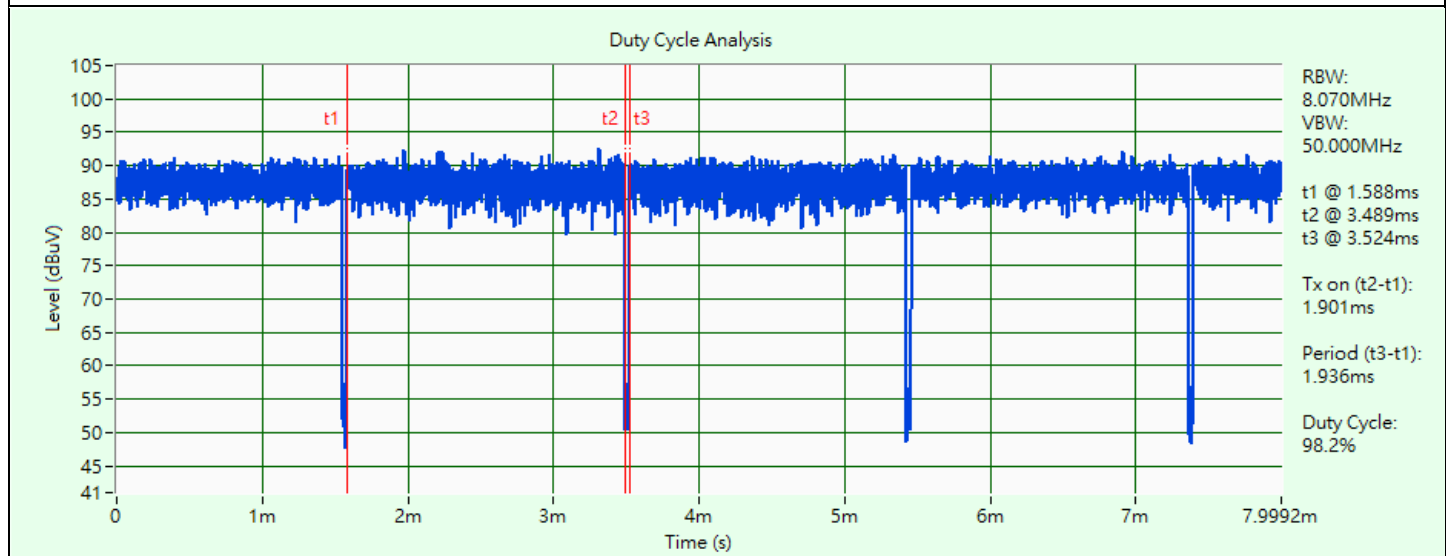

802.11ac (VHT20)

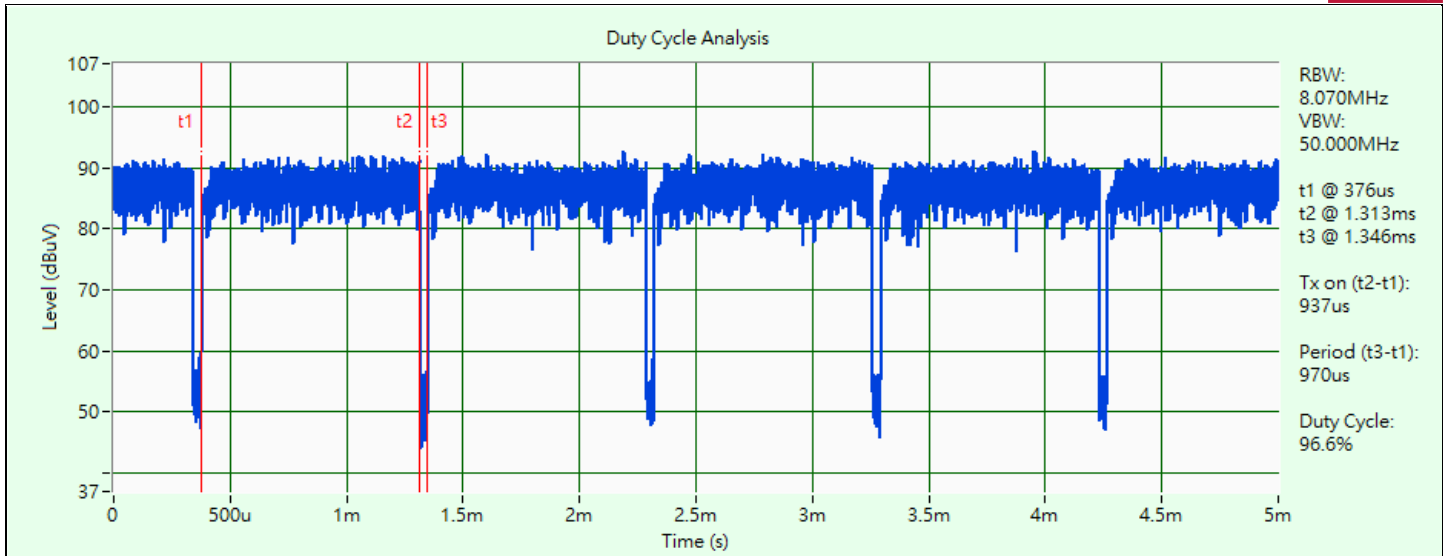

802.11ac (VHT40)

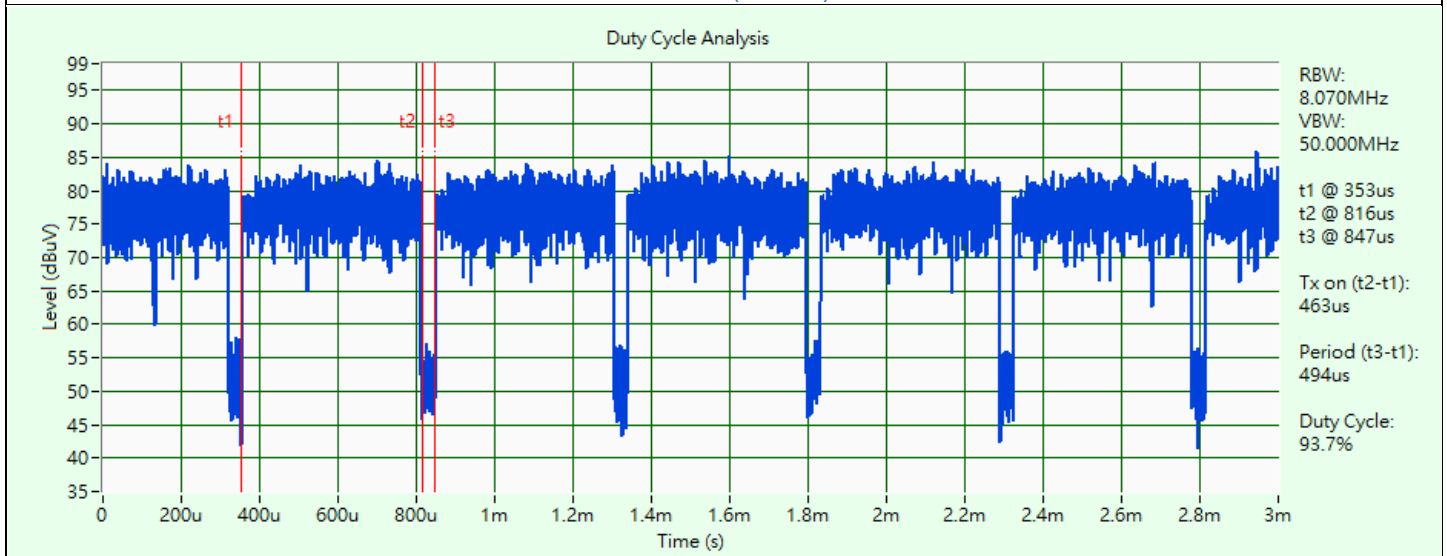

802.11ac (VHT80)

3.6 Test Program Used and Operation Descriptions

Controlling software (QRCT V4.0) has been activated to set the EUT under transmission condition continuously at specific channel frequency.

3.7 Connection Diagram of EUT and Peripheral Devices

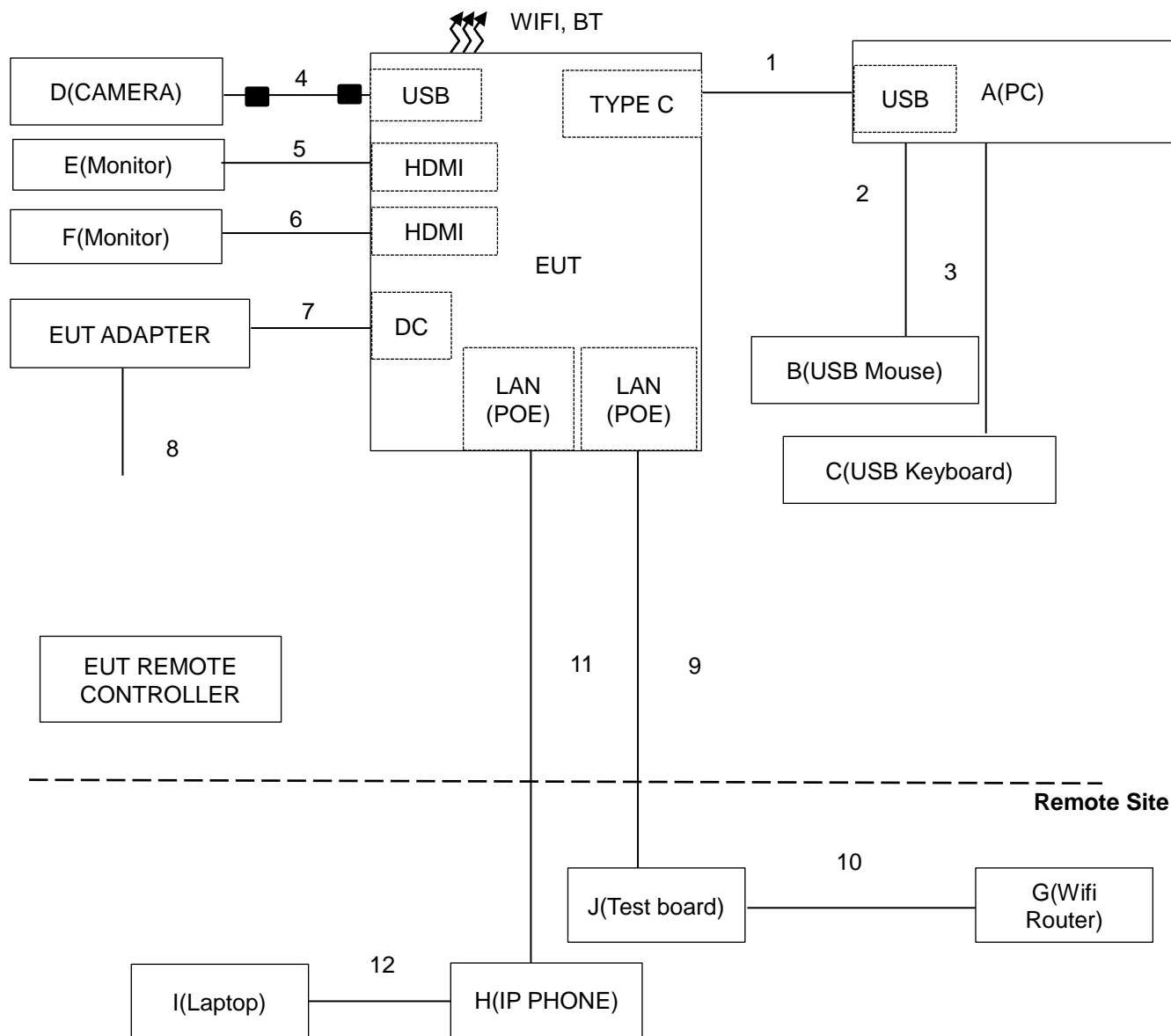

3.8 Configuration of Peripheral Devices and Cable Connections

ID	Product	Brand	Model No.	Serial No.	FCC ID	Remarks
A	PC	HP	Elite Desk 800G4	4CE92711L1	N/A	Provided by Lab
B	USB Mouse	DELL	MOCZUL	CN-049TWY- PRC00-77B-0083	N/A	Provided by Lab
C	USB Keyboard	DELL	KB216t	CN-0W33XP- LO300-7CL-191E	N/A	Provided by Lab
D	CAMERA	LOGITECH	C925e	N/A	N/A	Supplied by applicant
E	Monitor	ASUS	PA279CV	M7LMTF235956	DoC	Provided by Lab
F	Monitor	ASUS	PA279CV	M7LMTF235971	DoC	Provided by Lab
G	Wifi Router	ASUS	RT-AX88U	K8ITHP000169	MSQ- RTAXHP00	Provided by Lab
H	IP PHONE	AUDIOCODES	405HDG	AK12277044	N/A	Supplied by applicant
I	Laptop	LENOVO	T480	PF1EZSA2	N/A	Provided by Lab
J	Test board	TI	TPS23754EVM-383	N/A	N/A	Supplied by applicant

ID	Cable Descriptions	Qty.	Length (m)	Shielding (Yes/No)	Cores (Qty.)	Remarks
1	USB A to C cable	1	2.9	Yes	0	Supplied by applicant
2	USB cable	1	1.8	Yes	0	Provided by Lab
3	USB cable	1	1.8	Yes	0	Provided by Lab
4	USB cable	1	1.8	Yes	2	Supplied by applicant
5	HDMI cable	1	1.5	Yes	0	Supplied by applicant
6	HDMI cable	1	2	Yes	0	Provided by Lab
7	DC power cable	1	1.8	No	0	Supplied by applicant
8	AC power cable	1	2	No	0	Supplied by applicant
9	RJ45 (Cat. 5e) cable	1	10	Yes	0	Provided by Lab
10	RJ45 (Cat. 5e) cable	1	3	Yes	0	Provided by Lab
11	RJ45 (Cat. 5e) cable	1	10	Yes	0	Provided by Lab
12	RJ45 (Cat. 5e) cable	1	3	Yes	0	Provided by Lab

4 Test Instruments

The calibration interval of the all test instruments are 12 months and the calibrations are traceable to NML/ROC and NIST/USA.

4.1 26 dB Bandwidth

Description Manufacturer	Model No.	Serial No.	Calibrated Date	Calibrated Until
MIMO Power measurement Test set (4X4) KEYSIGHT	U2021XA	U2021XA_001	2022/6/13	2023/6/12
MXG Vector Signal Generator KEYSIGHT	N5182B	MY53052658	2022/5/9	2023/5/8
Peak Power meter Anritsu	ML2495A	0842014	2022/4/27	2023/4/26
Pulse Power Sensor Anritsu	MA2411B	0738404	2022/4/27	2023/4/26
Spectrum Analyzer KEYSIGHT	N9030A	MY54490260	2022/7/14	2023/7/13
Spectrum Analyzer R&S	FSV40	101042	2022/9/5	2023/9/4
		101544	2022/5/9	2023/5/8
Temperature & Humidity Chamber TERCHY	MHU-225AU	920409	2022/6/27	2023/6/26
Voltage Meter FLUKE	179	89610322	2022/10/3	2023/10/2

Notes:

1. The test was performed in LK - Oven
2. Tested Date: 2023/3/16

4.2 RF Output Power

Refer to section 4.1 to get information of the instruments.

4.3 Power Spectral Density

Refer to section 4.1 to get information of the instruments.

4.4 6 dB Bandwidth

Refer to section 4.1 to get information of the instruments.

4.5 Occupied Bandwidth

Refer to section 4.1 to get information of the instruments.

4.6 Frequency Stability

Refer to section 4.1 to get information of the instruments.

4.7 AC Power Conducted Emissions

Description Manufacturer	Model No.	Serial No.	Calibrated Date	Calibrated Until
50 ohm terminal LYNICS	0900510	E1-011285	2022/9/19	2023/9/18
		E1-011286	2022/9/19	2023/9/18
50 Ohms Terminator LYNICS	0900510	E1-01-305	2023/2/13	2024/2/12
Attenuator STI	STI02-2200-10	NO.4	2022/9/2	2023/9/1
DC LISN R&S	ESH3-Z6	100219	2022/8/2	2023/8/1
		844950/018	2022/8/2	2023/8/1
DC LISN Schwarzbeck	NNLK 8121	8121-808	2022/4/29	2023/4/28
High Voltage Probe Schwarzbeck	TK9420	00982	2022/12/14	2023/12/13
Isolation Transformer Erika Fiedler	D-65396	017	2022/9/8	2023/9/7
LISN R&S	ENV216	101196	2022/5/24	2023/5/23
LISN Schwarzbeck	NNLK 8121	8121-731	2022/5/26	2023/5/25
		8121-00759	2022/8/18	2023/8/17
	NNLK8129	8129229	2022/6/8	2023/6/7
	NSLK 8128	8128-244	2022/11/8	2023/11/7
RF Coaxial Cable Commate	5D-FB	Cable-CO5-01	2023/1/19	2024/1/18
Software BVADT	Cond_V7.3.7.4	N/A	N/A	N/A
Test Receiver R&S	ESR3	102412	2022/12/21	2023/12/20

Notes:

1. The test was performed in Linkou Conduction 5.
2. Tested Date: 2023/2/22

4.8 Unwanted Emissions below 1 GHz

Description Manufacturer	Model No.	Serial No.	Calibrated Date	Calibrated Until
* LOOP ANTENNA EMCI	LPA600	270	2021/9/2	2023/9/1
Bi_Log Antenna Schwarzbeck	VULB 9168	137	2022/10/21	2023/10/20
Coupling/Dcoupling Network Schwarzbeck	CDNE-M2	00097	2022/6/1	2023/5/31
	CDNE-M3	00091	2022/6/1	2023/5/31
Pre_Amplifier EMCI	EMC001340	980269	2022/6/28	2023/6/27
Pre_Amplifier HP	8447D	2432A03504	2023/2/16	2024/2/15
RF Coaxial Cable Pacific	8D-FB	Cable-CH6-02	2022/6/30	2023/6/29
Software BVADT	Radiated_V7.7.1.1.1	N/A	N/A	N/A
	Radiated_V8.7.08	N/A	N/A	N/A
Spectrum Analyzer R&S	FSV40	101544	2022/5/9	2023/5/8
Test Receiver Agilent	N9038A	MY51210129	2022/4/8	2023/4/7
		MY51210137	2022/6/9	2023/6/8
Tower ADT	AT100	0306	N/A	N/A
Turn Table ADT	TT100	0306	N/A	N/A

Notes:

- * The calibration interval of the above test instruments is 24 months and the calibrations are traceable to NML/ROC and NIST/USA
- The test was performed in Linkou 966 Chamber 6 (CH 6).
- Tested Date: 2023/2/21

4.9 Unwanted Emissions above 1 GHz

Description Manufacturer	Model No.	Serial No.	Calibrated Date	Calibrated Until
Band Pass Filter MICRO-TRONICS	BRM17690	005	2022/5/26	2023/5/25
Boresight antenna tower fixture BV	BAF-02	6	N/A	N/A
High Pass Filter Wainwright Instruments	WHK 3.1/18G-10SS	SN 8	2022/5/26	2023/5/25
Horn Antenna EMCO	3115	00028257	2022/11/13	2023/11/12
Horn Antenna ETS-Lindgren	3117-PA	00215857	2023/2/3	2024/2/2
Horn Antenna Schwarzbeck	BBHA 9170	212	2022/10/20	2023/10/19
Notch Filter MICRO-TRONICS	BRC50703-01	010	2022/5/26	2023/5/25
Pre-amplifier HP	8449B	3008A01201	2022/2/17 2023/2/16	2023/2/16 2024/2/15
Pre-amplifier (18GHz-40GHz) EMCI	EMC184045B	980175	2022/9/3	2023/9/2
Pre_Amplifier EMCI	EMC0126545	980076	2022/2/17 2023/2/16	2023/2/16 2024/2/15
	EMC184045B	980235	2022/2/17 2023/2/16	2023/2/16 2024/2/15
RF Coaxial Cable EM	EM102-KMKM-3.5+1M	EM102-KMKM-3.5+1M-01	2022/7/7	2023/7/6
RF Coaxial Cable EMCI	EMC104	190801	2022/9/20	2023/9/19
		190804	2022/9/20	2023/9/19
RF Coaxial Cable HUBER SUHNER	SF-104	Cable-CH6-01	2022/9/20	2023/9/19
Software BVADT	Radiated_V7.7.1.1.1	N/A	N/A	N/A
	Radiated_V8.7.08	N/A	N/A	N/A
Spectrum Analyzer R&S	FSV40	101042	2022/9/5	2023/9/4
		101544	2022/5/9	2023/5/8
Test Receiver Agilent	N9038A	MY51210129	2022/4/8	2023/4/7
		MY51210137	2022/6/9	2023/6/8
Tower ADT	AT100	0306	N/A	N/A
Turn Table ADT	TT100	0306	N/A	N/A

Notes:

1. The test was performed in Linkou 966 Chamber 6 (CH 6).
2. Tested Date: 2023/2/14 ~ 2023/2/17

5 Limits of Test Items

5.1 26 dB Bandwidth

The results are for reference only.

5.2 RF Output Power

Operation Band	EUT Category	Limit
U-NII-1	Outdoor Access Point	1 Watt (30 dBm) (Max. e.i.r.p \leq 125mW(21 dBm) at any elevation angle above 30 degrees as measured from the horizon)
	Fixed point-to-point Access Point	1 Watt (30 dBm)
	Indoor Access Point	1 Watt (30 dBm)
	Mobile and Portable client device	250mW (24 dBm)

Operation Band	Limit
U-NII-2A	250 mW (24 dBm) or 11 dBm+10 log B*
U-NII-2C	250 mW (24 dBm) or 11 dBm+10 log B*
U-NII-3	1 Watt (30 dBm)

*B is the 26 dB emission bandwidth in megahertz

5.3 Power Spectral Density

Operation Band	EUT Category	Limit
U-NII-1	Outdoor Access Point	17 dBm/MHz
	Fixed point-to-point Access Point	
	Indoor Access Point	
	Mobile and Portable client device	11 dBm/MHz

Operation Band	Limit
U-NII-2A	11 dBm/MHz
U-NII-2C	11 dBm/MHz
U-NII-3	30 dBm/500 kHz

5.4 6 dB Bandwidth

Within the 5.725-5.850 GHz band, the minimum 6 dB bandwidth of U-NII devices shall be at least 500 kHz.

5.5 Occupied Bandwidth

The results are for reference only.

5.6 Frequency Stability

The frequency of the carrier signal shall be maintained within band of operation.

5.7 AC Power Conducted Emissions

Frequency (MHz)	Conducted Limit (dBuV)	
	Quasi-peak	Average
0.15 - 0.5	66 - 56	56 - 46
0.50 - 5.0	56	46
5.0 - 30.0	60	50

Notes:

1. The lower limit shall apply at the transition frequencies.
2. The limit decreases in line with the logarithm of the frequency in the range of 0.15 to 0.50 MHz.

5.8 Unwanted Emissions below 1 GHz

Radiated emissions which fall in the restricted bands must comply with the radiated emission limits specified as below table.

Frequencies (MHz)	Field Strength (microvolts/meter)	Measurement Distance (meters)
0.009 ~ 0.490	2400/F(kHz)	300
0.490 ~ 1.705	24000/F(kHz)	30
1.705 ~ 30.0	30	30
30 ~ 88	100	3
88 ~ 216	150	3
216 ~ 960	200	3
Above 960	500	3

Notes:

1. The lower limit shall apply at the transition frequencies.
2. Emission level (dBuV/m) = 20 log Emission level (uV/m).

5.9 Unwanted Emissions above 1 GHz

Radiated emissions which fall in the restricted bands must comply with the radiated emission limits specified as below table.

Frequencies (MHz)	Field Strength (microvolts/meter)	Measurement Distance (meters)
Above 960	500	3

Notes:

1. The lower limit shall apply at the transition frequencies.
2. Emission level (dBuV/m) = 20 log Emission level (uV/m).
3. For frequencies above 1000 MHz, the field strength limits are based on average detector, however, the peak field strength of any emission shall not exceed the maximum permitted average limits, specified above by more than 20 dB under any condition of modulation.

Limits of unwanted emission out of the restricted bands

Applicable To	Limit	
789033 D02 General UNII Test Procedure New Rules v02r01	Field Strength at 3 m	
	PK: 74 (dBμV/m)	AV: 54 (dBμV/m)

For transmitters operating in the 5.15-5.25 GHz band:

Applicable To	EIRP Limit	Equivalent Field Strength at 3 m
15.407(b)(1)	PK: -27 (dBm/MHz)	PK: 68.2 (dBμV/m)

For transmitters operating in the 5.25-5.35 GHz band:

Applicable To	EIRP Limit	Equivalent Field Strength at 3 m
15.407(b)(2)	PK: -27 (dBm/MHz)	PK: 68.2 (dBμV/m)

For transmitters operating in the 5.47-5.725 GHz band:

Applicable To	EIRP Limit	Equivalent Field Strength at 3 m
15.407(b)(3)	PK: -27 (dBm/MHz)	PK: 68.2 (dBμV/m)

For transmitters operating in the 5.725-5.850 GHz band:

Applicable To	EIRP Limit	Equivalent Field Strength at 3 m
15.407(b)(4)(i)	PK: -27 (dBm/MHz) ^{*1}	PK: 68.2 (dBμV/m) ^{*1}
	PK: 10 (dBm/MHz) ^{*2}	PK: 105.2 (dBμV/m) ^{*2}
	PK: 15.6 (dBm/MHz) ^{*3}	PK: 110.8 (dBμV/m) ^{*3}
	PK: 27 (dBm/MHz) ^{*4}	PK: 122.2 (dBμV/m) ^{*4}

^{*1} beyond 75 MHz or more above of the band edge.

^{*2} below the band edge increasing linearly to 10 dBm/MHz at 25 MHz above.

^{*3} below the band edge increasing linearly to a level of 15.6 dBm/MHz at 5 MHz above.

^{*4} from 5 MHz above or below the band edge increasing linearly to a level of 27 dBm/MHz at the band edge.

Note: The following formula is used to convert the equipment isotropic radiated power (eirp) to field strength:

$$E = \frac{1000000\sqrt{30P}}{3} \mu\text{V/m, where P is the eirp (Watts).}$$

6 Test Arrangements

6.1 26 dB Bandwidth

6.1.1 Test Setup

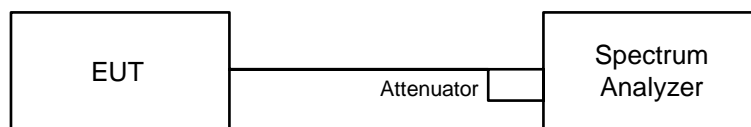

6.1.2 Test Procedure

- Set RBW = approximately 1% of the emission bandwidth.
- Set the VBW > RBW.
- Detector = Peak.
- Trace mode = max hold.
- Measure the maximum width of the emission that is 26 dB down from the peak of the emission. Compare this with the RBW setting of the analyzer. Readjust RBW and repeat measurement as needed until the RBW/EBW ratio is approximately 1%.

6.2 RF Output Power

6.2.1 Test Setup

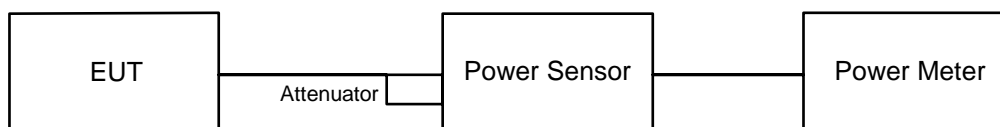

6.2.2 Test Procedure

Method PM is used to perform output power measurement, trigger and gating function of wide band power meter is enabled to measure max output power of TX on burst and set the detector to average. Duty factor is not added to measured value.

6.3 Power Spectral Density

6.3.1 Test Setup

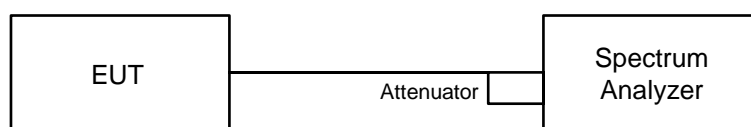

6.3.2 Test Procedure

For specified measurement bandwidth 1 MHz:

Method SA-1

- Set span to encompass the entire emission bandwidth (EBW) of the signal.
- Set RBW = 1 MHz, Set VBW ≥ 3 MHz, Detector = RMS
- Sweep points ≥ $[2 \times \text{span} / \text{RBW}]$. (This gives bin-to-bin spacing ≤ RBW / 2, so that narrowband signals are not lost between frequency bins.)
- Sweep time = auto, trigger set to "free run".
- Trace average at least 100 traces in power averaging mode.

- f. Record the max value

For specified measurement bandwidth 1 MHz:

Method SA-2

- a. Set span to encompass the entire emission bandwidth (EBW) of the signal.
- b. Set RBW = 1 MHz, Set VBW \geq 3 MHz, Detector = RMS
- c. Sweep points \geq $[2 \times \text{span} / \text{RBW}]$. (This gives bin-to-bin spacing \leq RBW / 2, so that narrowband signals are not lost between frequency bins.)
- d. Sweep time = auto, trigger set to “free run”.
- e. Trace average at least 100 traces in power averaging mode.
- f. Use the peak search function on the instrument to find the peak of the spectrum and record its value.
- g. Record the max value and add 10 log (1/duty cycle).

For specified measurement bandwidth 500 kHz:

Method SA-1

- a. Set span to encompass the entire emission bandwidth (EBW) of the signal.
- b. Set RBW = 300 kHz, Set VBW \geq 1 MHz, Detector = RMS
- c. Scale the observed power level to an equivalent value in 500 kHz by adjusting (increasing) the measured power by a bandwidth correction factor (BWCF) where $\text{BWCF} = 10\log(500 \text{ kHz}/300 \text{ kHz})$
- d. Sweep points \geq $[2 \times \text{span} / \text{RBW}]$. (This gives bin-to-bin spacing \leq RBW / 2, so that narrowband signals are not lost between frequency bins.)
- e. Sweep time = auto, trigger set to “free run”.
- f. Trace average at least 100 traces in power averaging mode.
- g. Record the max value

For specified measurement bandwidth 500 kHz:

Method SA-2

- a. Set span to encompass the entire emission bandwidth (EBW) of the signal.
- b. Set RBW = 300 kHz, Set VBW \geq 1 MHz, Detector = RMS
- c. Scale the observed power level to an equivalent value in 500 kHz by adjusting (increasing) the measured power by a bandwidth correction factor (BWCF) where $\text{BWCF} = 10\log(500 \text{ kHz}/300 \text{ kHz})$
- d. Sweep points \geq $[2 \times \text{span} / \text{RBW}]$. (This gives bin-to-bin spacing \leq RBW / 2, so that narrowband signals are not lost between frequency bins.)
- e. Sweep time = auto, trigger set to “free run”.
- f. Trace average at least 100 traces in power averaging mode.
- g. Use the peak search function on the instrument to find the peak of the spectrum and record its value.
- h. Record the max value and add 10 log (1/duty cycle).

6.4 6 dB Bandwidth

6.4.1 Test Setup

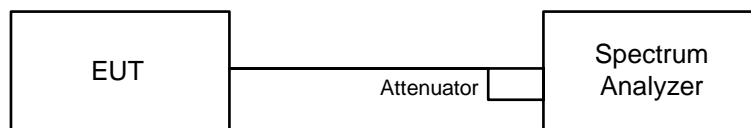

6.4.2 Test Procedure

- Set resolution bandwidth (RBW) = 100 kHz.
- Set the video bandwidth (VBW) $\geq 3 \times$ RBW, Detector = Peak.
- Trace mode = max hold.
- Sweep = auto couple.
- Measure the maximum width of the emission that is constrained by the frequencies associated with the two amplitude points (upper and lower) that are attenuated by 6 dB relative to the maximum level measured in the fundamental emission.

6.5 Occupied Bandwidth

6.5.1 Test Setup

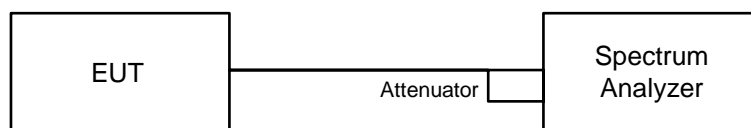

6.5.2 Test Procedure

The transmitter output was connected to the spectrum analyzer through an attenuator. The bandwidth of the fundamental frequency was measured by spectrum analyzer with resolution bandwidth in the range of 1% to 5% of the anticipated emission bandwidth, and a video bandwidth at least 3x the resolution bandwidth and set the detector to Sampling. The width of a frequency band such that, below the lower and above the upper frequency limits, the mean powers emitted are each equal to a specified percentage 0.5% of the total mean power of a given emission.

6.6 Frequency Stability

6.6.1 Test Setup

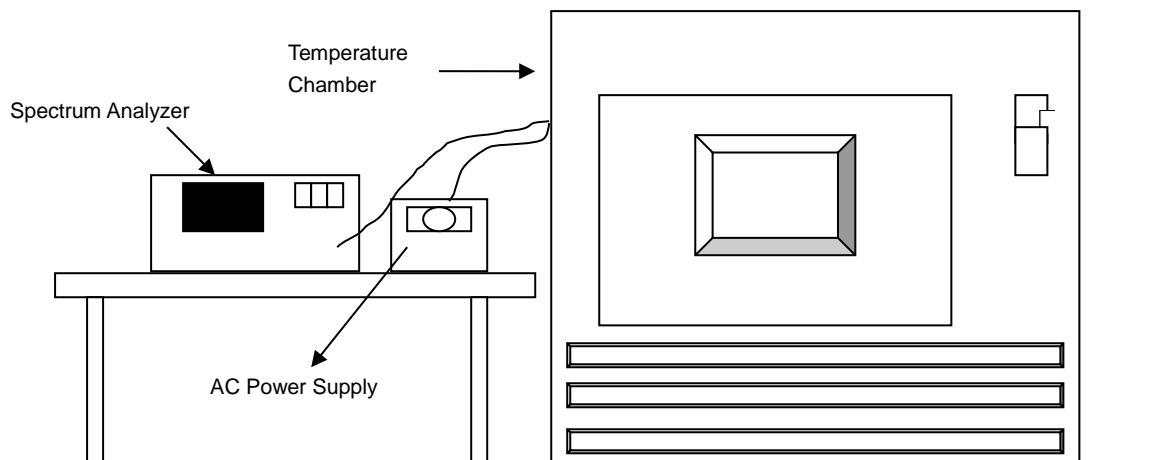

6.6.2 Test Procedure

- The EUT was placed inside the environmental test chamber and powered by nominal AC voltage.
- Turn the EUT on and couple its output to a spectrum analyzer.
- Turn the EUT off and set the chamber to the highest temperature specified.
- Allow sufficient time (approximately 30 min) for the temperature of the chamber to stabilize, turn the EUT on and measure the operating frequency after 2, 5, and 10 Minutes.
- Repeat step (d) with the temperature chamber set to the next desired temperature until measurements down to the lowest specified temperature have been completed.
- The test chamber was allowed to stabilize at +20 degree C for a minimum of 30 Minutes. The supply voltage was then adjusted on the EUT from 85% to 115% and the frequency record.

6.7 AC Power Conducted Emissions

6.7.1 Test Setup

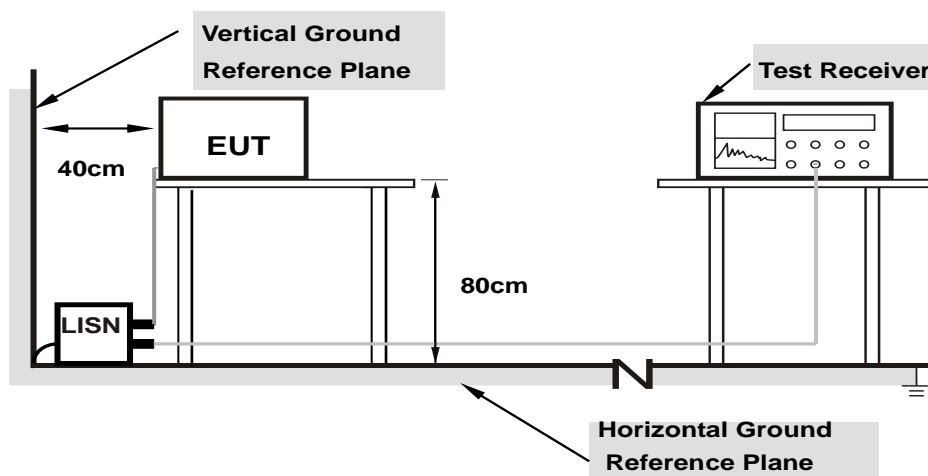

Note: 1.Support units were connected to second LISN.

For the actual test configuration, please refer to the attached file (Test Setup Photo).

6.7.2 Test Procedure

- The EUT was placed on a 0.8 meter to the top of table and placed 0.4 meters from the conducting wall of the shielded room with EUT being connected to the power mains through a line impedance stabilization network (LISN). Other support units were connected to the power mains through another LISN. The two LISNs provide 50 ohm/ 50 uH of coupling impedance for the measuring instrument.
- Both lines of the power mains connected to the EUT were checked for maximum conducted interference.
- The frequency range from 150 kHz to 30 MHz was searched. Emission levels under (Limit – 20 dB) was not recorded.

Note: The resolution bandwidth and video bandwidth of test receiver is 9 kHz for quasi-peak detection (QP) and average detection (AV) at frequency 0.15 MHz-30 MHz.

6.8 Unwanted Emissions below 1 GHz

6.8.1 Test Setup

For Radiated emission below 30 MHz

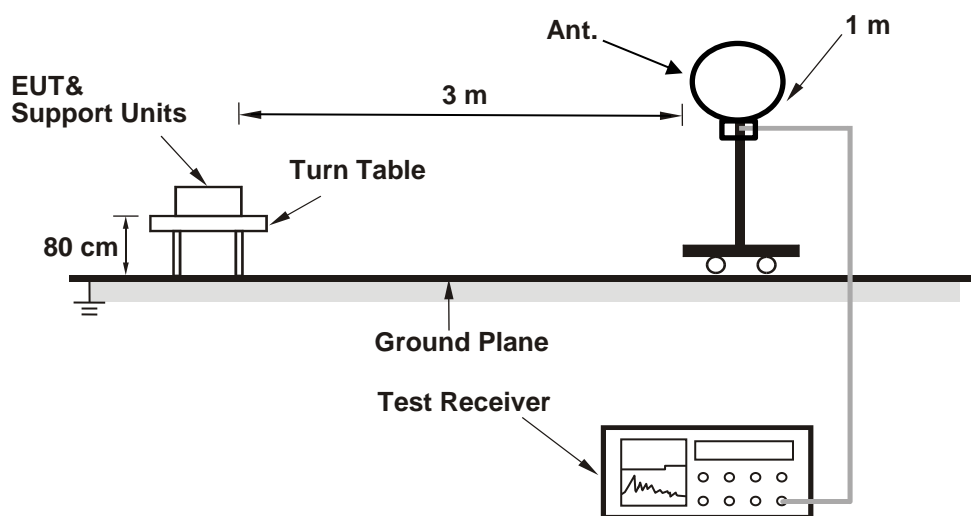

For Radiated emission above 30 MHz

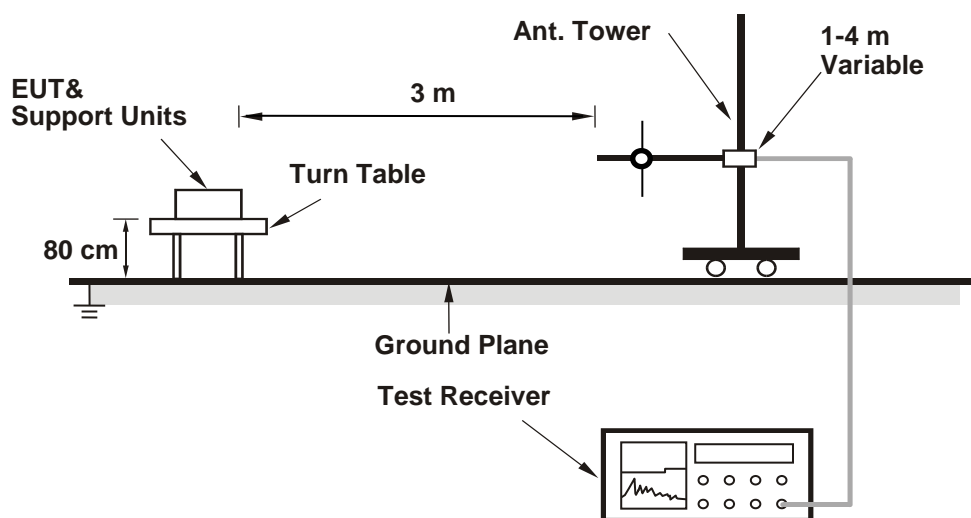

For the actual test configuration, please refer to the attached file (Test Setup Photo).

6.8.2 Test Procedure

For Radiated emission below 30 MHz

- a. The EUT was placed on the top of a rotating table 0.8 meters above the ground at 3 meter chamber room for test. The table was rotated 360 degrees to determine the position of the highest radiation.
- b. The EUT was set 3 meters away from the interference-receiving antenna, which was mounted on the top of a variable-height antenna tower.
- c. Parallel, perpendicular, and ground-parallel orientations of the antenna are set to make the measurement.
- d. For each suspected emission, the EUT was arranged to its worst case and the rotatable table was turned from 0 degrees to 360 degrees to find the maximum reading.
- e. The test-receiver system was set to Quasi-Peak Detect Function and Specified Bandwidth with Maximum Hold Mode, except for the frequency band (9 kHz to 90 kHz and 110 kHz to 490 kHz) set to average detect function and peak detect function.

Notes:

1. The resolution bandwidth and video bandwidth of test receiver/spectrum analyzer is 200 Hz at frequency below 150 kHz.
2. The resolution bandwidth and video bandwidth of test receiver/spectrum analyzer is 9 kHz or 10 kHz at frequency (150 kHz to 30 MHz).
3. All modes of operation were investigated and the worst-case emissions are reported.

For Radiated emission above 30 MHz

- a. The EUT was placed on the top of a rotating table 0.8 meters above the ground at 3 meter chamber room for test. The table was rotated 360 degrees to determine the position of the highest radiation.
- b. The EUT was set 3 meters away from the interference-receiving antenna, which was mounted on the top of a variable-height antenna tower.
- c. The height of antenna is varied from one meter to four meters above the ground to determine the maximum value of the field strength. Both horizontal and vertical polarizations of the antenna are set to make the measurement.
- d. For each suspected emission, the EUT was arranged to its worst case and then the antenna was tuned to heights from 1 meter to 4 meters and the rotatable table was turned from 0 degrees to 360 degrees to find the maximum reading.
- e. The test-receiver system was set to quasi-peak detect function and specified bandwidth with maximum hold mode when the test frequency is below 1 GHz.

Notes:

1. The resolution bandwidth and video bandwidth of test receiver/spectrum analyzer is 120 kHz for Quasi-peak detection (QP) at frequency below 1 GHz.
2. All modes of operation were investigated and the worst-case emissions are reported.

6.9 Unwanted Emissions above 1 GHz

6.9.1 Test Setup

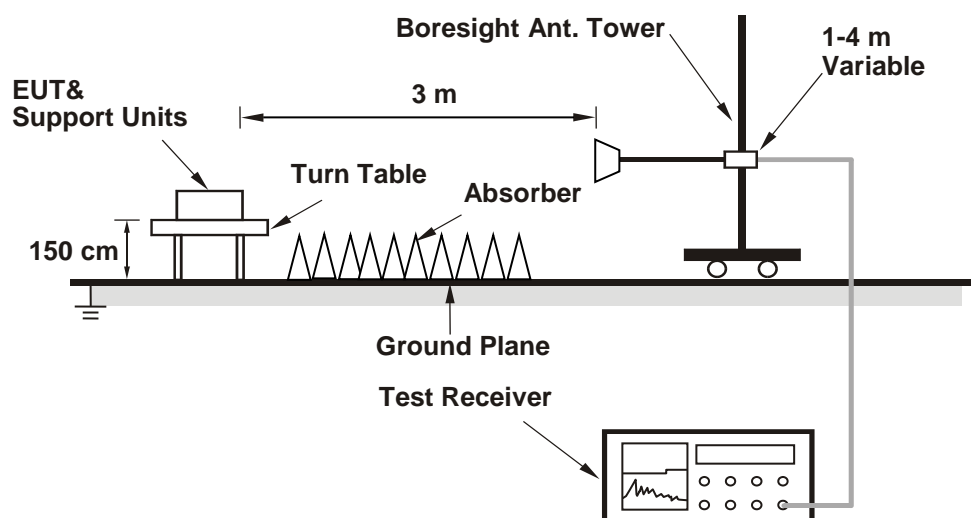

For the actual test configuration, please refer to the attached file (Test Setup Photo).

6.9.2 Test Procedure

- The EUT was placed on the top of a rotating table 1.5 meters above the ground at 3 meter chamber room for test. The table was rotated 360 degrees to determine the position of the highest radiation.
- The EUT was set 3 meters away from the interference-receiving antenna, which was mounted on the top of a variable-height antenna tower.
- The height of antenna is varied from one meter to four meters above the ground to determine the maximum value of the field strength. Both horizontal and vertical polarizations of the antenna are set to make the measurement.
- For each suspected emission, the EUT was arranged to its worst case and then the antenna was tuned to heights from 1 meter to 4 meters and the rotatable table was turned from 0 degrees to 360 degrees to find the maximum reading.
- The test-receiver system was set to peak and average detects function and specified bandwidth with maximum hold mode when the test frequency is above 1 GHz. If the peak reading value also meets average limit, measurement with the average detector is unnecessary.

Notes:

- The resolution bandwidth of test receiver/spectrum analyzer is 1 MHz and the video bandwidth is 3 MHz for Peak detection (PK) and Average detection (AV) at frequency above 1 GHz.
- For fundamental and harmonic signal measurement, the resolution bandwidth of test receiver/spectrum analyzer is 1 MHz and the video bandwidth is $\geq 1/T$ (Duty cycle $< 98\%$) or 10 Hz (Duty cycle $\geq 98\%$) for Average detection (AV) at frequency above 1 GHz.
- All modes of operation were investigated and the worst-case emissions are reported.

7 Test Results of Test Item

7.1 26 dB Bandwidth

Input Power:	120 Vac, 60 Hz	Environmental Conditions:	25°C, 76% RH	Tested By:	Dalen Dai
--------------	----------------	---------------------------	--------------	------------	-----------

802.11a

Channel	Frequency (MHz)	26dB Bandwidth (MHz)
52	5260	25.14
60	5300	24.28
64	5320	24.03
100	5500	24.87
116	5580	24.21
140	5700	24.26

Determined Output Power Limit			
Channel Number	Freq.(MHz)	Min. B(MHz)	Determined Conducted Power Limit (dBm)
52	5260	25.14	25 > 24
60	5300	24.28	24.85 > 24
64	5320	24.03	24.8 > 24
100	5500	24.87	24.95 > 24
116	5580	24.21	24.83 > 24
140	5700	24.26	24.84 > 24

Note: For U-NII-2A, U-NII-2C Band output power limitation is determined based on 26dBc bandwidth.

802.11ac (VHT20)

Channel	Frequency (MHz)	26dB Bandwidth (MHz)
52	5260	25.66
60	5300	25.61
64	5320	25.93
100	5500	25.79
116	5580	25.22
140	5700	26.07

Determined Output Power Limit			
Channel Number	Freq.(MHz)	Min. B(MHz)	Determined Conducted Power Limit (dBm)
52	5260	25.66	25.09 > 24
60	5300	25.61	25.08 > 24
64	5320	25.93	25.13 > 24
100	5500	25.79	25.11 > 24
116	5580	25.22	25.01 > 24
140	5700	26.07	25.16 > 24

Note: For U-NII-2A, U-NII-2C Band output power limitation is determined based on 26dBc bandwidth.

802.11ac (VHT40)

Channel	Frequency (MHz)	26dB Bandwidth (MHz)
54	5270	42.39
62	5310	42.62
102	5510	42.05
110	5550	42.59
134	5670	42.74

Determined Output Power Limit			
Channel Number	Freq.(MHz)	Min. B(MHz)	Determined Conducted Power Limit (dBm)
54	5270	42.39	27.27 > 24
62	5310	42.62	27.29 > 24
102	5510	42.05	27.23 > 24
110	5550	42.59	27.29 > 24
134	5670	42.74	27.3 > 24

Note: For U-NII-2A, U-NII-2C Band output power limitation is determined based on 26dBc bandwidth.

802.11ac (VHT80)

Channel	Frequency (MHz)	26dB Bandwidth (MHz)
58	5290	86.1
106	5530	85.05
122	5610	84.49

Determined Output Power Limit

Channel Number	Freq.(MHz)	Min. B(MHz)	Determined Conducted Power Limit (dBm)	
58	5290	86.10	30.35	> 24
106	5530	85.05	30.29	> 24
122	5610	84.49	30.26	> 24

Note: For U-NII-2A, U-NII-2C Band output power limitation is determined based on 26dBc bandwidth.

Spectrum Plot of Minimum Value

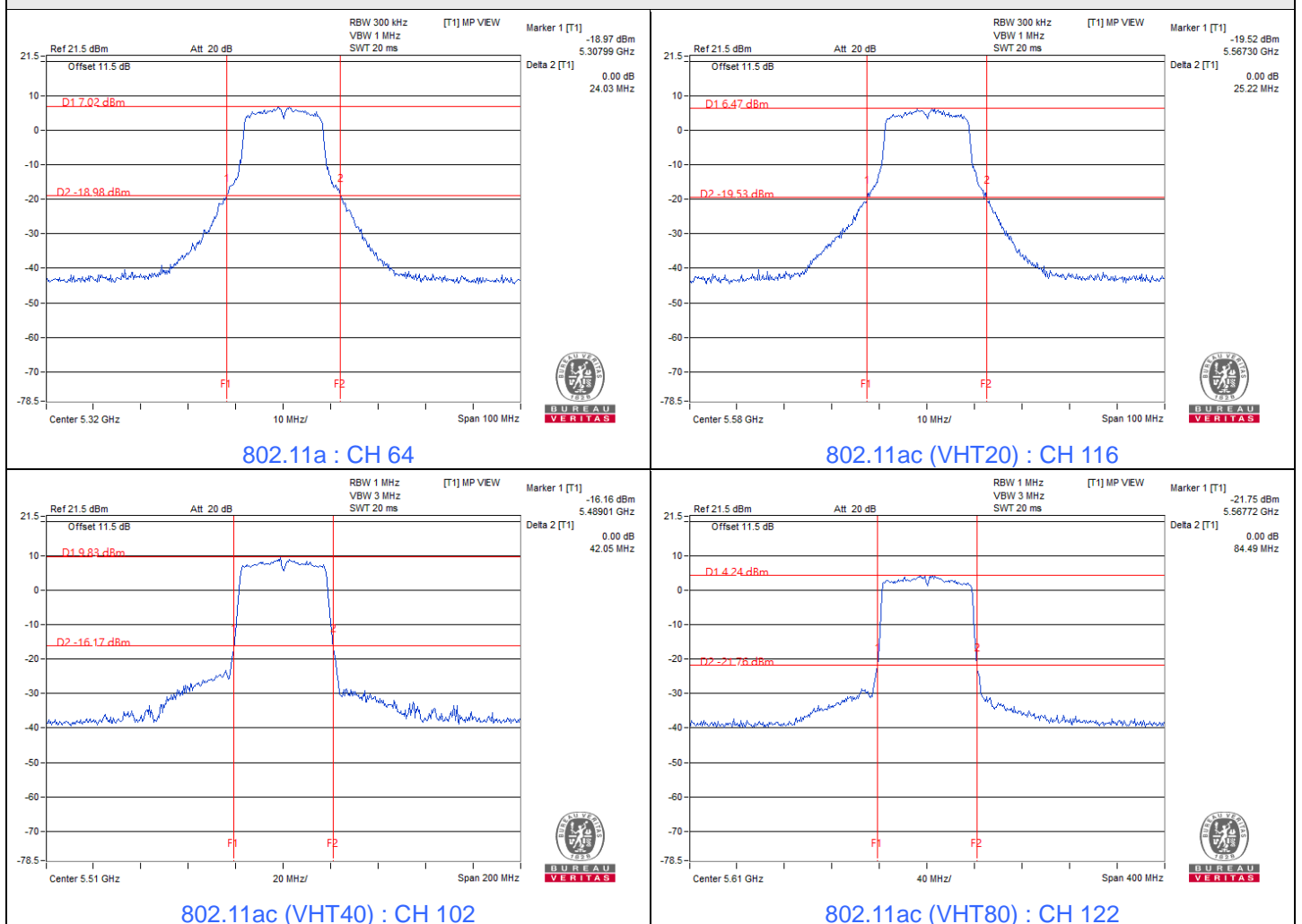

7.2 RF Output Power

Input Power:	120 Vac, 60 Hz	Environmental Conditions:	25°C, 76% RH	Tested By:	Dalen Dai
--------------	----------------	---------------------------	--------------	------------	-----------

802.11a

Chan.	Chan. Freq. (MHz)	Average Power (mW)	Average Power (dBm)	Power Limit (dBm)	Test Result
36	5180	34.754	15.41	24	Pass
40	5200	34.514	15.38	24	Pass
48	5240	35.727	15.53	24	Pass
52	5260	36.058	15.57	24	Pass
60	5300	33.963	15.31	24	Pass
64	5320	34.198	15.34	24	Pass
100	5500	34.754	15.41	24	Pass
116	5580	34.356	15.36	24	Pass
140	5700	36.308	15.60	24	Pass
149	5745	34.277	15.35	30	Pass
157	5785	34.594	15.39	30	Pass
165	5825	33.651	15.27	30	Pass

Notes:

1. For U-NII-1, the antenna gain is 4.54 dBi < 6 dBi, so the output power limit shall not be reduced.
2. For U-NII-2A, the antenna gain is 4.54 dBi < 6 dBi, so the output power limit shall not be reduced.
3. For U-NII-2C, the antenna gain is 4.54 dBi < 6 dBi, so the output power limit shall not be reduced.
4. For U-NII-3, the antenna gain is 4.54 dBi < 6 dBi, so the output power limit shall not be reduced.

802.11ac (VHT20)

Chan.	Chan. Freq. (MHz)	Average Power (mW)	Average Power (dBm)	Power Limit (dBm)	Test Result
36	5180	34.754	15.41	24	Pass
40	5200	34.514	15.38	24	Pass
48	5240	34.834	15.42	24	Pass
52	5260	35.481	15.50	24	Pass
60	5300	34.435	15.37	24	Pass
64	5320	34.594	15.39	24	Pass
100	5500	37.068	15.69	24	Pass
116	5580	34.198	15.34	24	Pass
140	5700	34.834	15.42	24	Pass
149	5745	34.041	15.32	30	Pass
157	5785	34.119	15.33	30	Pass
165	5825	35.645	15.52	30	Pass

Notes:

1. For U-NII-1, the antenna gain is 4.54 dBi < 6 dBi, so the output power limit shall not be reduced.
2. For U-NII-2A, the antenna gain is 4.54 dBi < 6 dBi, so the output power limit shall not be reduced.
3. For U-NII-2C, the antenna gain is 4.54 dBi < 6 dBi, so the output power limit shall not be reduced.
4. For U-NII-3, the antenna gain is 4.54 dBi < 6 dBi, so the output power limit shall not be reduced.

802.11ac (VHT40)

Chan.	Chan. Freq. (MHz)	Average Power (mW)	Average Power (dBm)	Power Limit (dBm)	Test Result
38	5190	27.733	14.43	24	Pass
46	5230	27.925	14.46	24	Pass
54	5270	27.416	14.38	24	Pass
62	5310	27.606	14.41	24	Pass
102	5510	29.174	14.65	24	Pass
110	5550	27.479	14.39	24	Pass
134	5670	27.861	14.45	24	Pass
151	5755	27.542	14.40	30	Pass
159	5795	27.925	14.46	30	Pass

Notes:

1. For U-NII-1, the antenna gain is 4.54 dBi < 6 dBi, so the output power limit shall not be reduced.
2. For U-NII-2A, the antenna gain is 4.54 dBi < 6 dBi, so the output power limit shall not be reduced.
3. For U-NII-2C, the antenna gain is 4.54 dBi < 6 dBi, so the output power limit shall not be reduced.
4. For U-NII-3, the antenna gain is 4.54 dBi < 6 dBi, so the output power limit shall not be reduced.

802.11ac (VHT80)

Chan.	Chan. Freq. (MHz)	Average Power (mW)	Average Power (dBm)	Power Limit (dBm)	Test Result
42	5210	13.243	11.22	24	Pass
58	5290	21.232	13.27	24	Pass
106	5530	11.83	10.73	24	Pass
122	5610	22.856	13.59	24	Pass
155	5775	24.322	13.86	30	Pass

Notes:

1. For U-NII-1, the antenna gain is 4.54 dBi < 6 dBi, so the output power limit shall not be reduced.
2. For U-NII-2A, the antenna gain is 4.54 dBi < 6 dBi, so the output power limit shall not be reduced.
3. For U-NII-2C, the antenna gain is 4.54 dBi < 6 dBi, so the output power limit shall not be reduced.
4. For U-NII-3, the antenna gain is 4.54 dBi < 6 dBi, so the output power limit shall not be reduced.

7.3 Power Spectral Density

Input Power:	120 Vac, 60 Hz	Environmental Conditions:	25°C, 76% RH	Tested By:	Dalen Dai
--------------	----------------	---------------------------	--------------	------------	-----------

802.11a

Chan.	Chan. Freq. (MHz)	PSD (dBm/MHz)	Max. PSD Limit (dBm/MHz)	Test Result
36	5180	2.24	11.00	Pass
40	5200	2.31	11.00	Pass
48	5240	2.28	11.00	Pass
52	5260	2.17	11.00	Pass
60	5300	2.25	11.00	Pass
64	5320	2.20	11.00	Pass
100	5500	2.18	11.00	Pass
116	5580	2.09	11.00	Pass
140	5700	2.11	11.00	Pass

Notes:

1. For U-NII-1, the antenna gain is 4.54 dBi < 6dBi, so the power density limit shall not be reduced.
2. For U-NII-2A, the antenna gain is 4.54 dBi < 6 dBi, so the power density limit shall not be reduced.
3. For U-NII-2C, the antenna gain is 4.54 dBi < 6 dBi, so the power density limit shall not be reduced.

802.11ac (VHT20)

Chan.	Chan. Freq. (MHz)	PSD (dBm/MHz)	Max. PSD Limit (dBm/MHz)	Test Result
36	5180	1.90	11.00	Pass
40	5200	1.91	11.00	Pass
48	5240	2.00	11.00	Pass
52	5260	1.77	11.00	Pass
60	5300	1.89	11.00	Pass
64	5320	1.98	11.00	Pass
100	5500	2.02	11.00	Pass
116	5580	1.65	11.00	Pass
140	5700	1.78	11.00	Pass

Notes:

1. For U-NII-1, the antenna gain is 4.54 dBi < 6dBi, so the power density limit shall not be reduced.
2. For U-NII-2A, the antenna gain is 4.54 dBi < 6 dBi, so the power density limit shall not be reduced.
3. For U-NII-2C, the antenna gain is 4.54 dBi < 6 dBi, so the power density limit shall not be reduced.

802.11ac (VHT40)

Chan.	Chan. Freq. (MHz)	PSD w/o Duty Factor (dBm/MHz)	Duty Factor (dB)	PSD (dBm/MHz)	Max. PSD Limit (dBm/MHz)	Test Result
38	5190	-1.72	0.15	-1.57	11.00	Pass
46	5230	-1.78	0.15	-1.63	11.00	Pass
54	5270	-1.90	0.15	-1.75	11.00	Pass
62	5310	-1.81	0.15	-1.66	11.00	Pass
102	5510	-1.59	0.15	-1.44	11.00	Pass
110	5550	-1.77	0.15	-1.62	11.00	Pass
134	5670	-1.68	0.15	-1.53	11.00	Pass

Notes:

1. For U-NII-1, the antenna gain is 4.54 dBi < 6dBi, so the power density limit shall not be reduced.
2. For U-NII-2A, the antenna gain is 4.54 dBi < 6 dBi, so the power density limit shall not be reduced.
3. For U-NII-2C, the antenna gain is 4.54 dBi < 6 dBi, so the power density limit shall not be reduced.

802.11ac (VHT80)

Chan.	Chan. Freq. (MHz)	PSD w/o Duty Factor (dBm/MHz)	Duty Factor (dB)	PSD (dBm/MHz)	Max. PSD Limit (dBm/MHz)	Test Result
42	5210	-8.27	0.28	-7.99	11.00	Pass
58	5290	-6.24	0.28	-5.96	11.00	Pass
106	5530	-8.87	0.28	-8.59	11.00	Pass
122	5610	-6.05	0.28	-5.77	11.00	Pass

Notes:

1. For U-NII-1, the antenna gain is 4.54 dBi < 6dBi, so the power density limit shall not be reduced.
2. For U-NII-2A, the antenna gain is 4.54 dBi < 6 dBi, so the power density limit shall not be reduced.
3. For U-NII-2C, the antenna gain is 4.54 dBi < 6 dBi, so the power density limit shall not be reduced.

802.11a

Channel	Freq. (MHz)	PSD (dBm/300kHz)	PSD (dBm/500kHz)	PSD Limit (dBm/500kHz)	Test Result
149	5745	-5.75	-3.53	30	Pass
157	5785	-5.83	-3.61	30	Pass
165	5825	-5.93	-3.71	30	Pass

Note: For U-NII-3, the antenna gain is 4.54 dBi < 6 dBi, so the power density limit shall not be reduced.

802.11ac (VHT20)

Channel	Freq. (MHz)	PSD (dBm/300kHz)	PSD (dBm/500kHz)	PSD Limit (dBm/500kHz)	Test Result
149	5745	-6.06	-3.84	30	Pass
157	5785	-6.21	-3.99	30	Pass
165	5825	-6.39	-4.17	30	Pass

Note: For U-NII-3, the antenna gain is 4.54 dBi < 6 dBi, so the power density limit shall not be reduced.

802.11ac (VHT40)

Channel	Freq. (MHz)	PSD w/o Duty Factor (dBm/300kHz)	PSD w/o Duty Factor (dBm/500kHz)	Duty Factor (dB)	Total PSD With Duty Factor (dBm/500kHz)	PSD Limit (dBm/500kHz)	Test Result
151	5755	-10.6	-8.38	0.15	-8.23	30	Pass
159	5795	-10.63	-8.41	0.15	-8.26	30	Pass

Note: For U-NII-3, the antenna gain is 4.54 dBi < 6 dBi, so the power density limit shall not be reduced.

802.11ac (VHT80)

Channel	Freq. (MHz)	PSD w/o Duty Factor (dBm/300kHz)	PSD w/o Duty Factor (dBm/500kHz)	Duty Factor (dB)	Total PSD With Duty Factor (dBm/500kHz)	PSD Limit (dBm/500kHz)	Test Result
155	5775	-14.63	-12.41	0.28	-12.13	30	Pass

Note: For U-NII-3, the antenna gain is 4.54 dBi < 6 dBi, so the power density limit shall not be reduced.

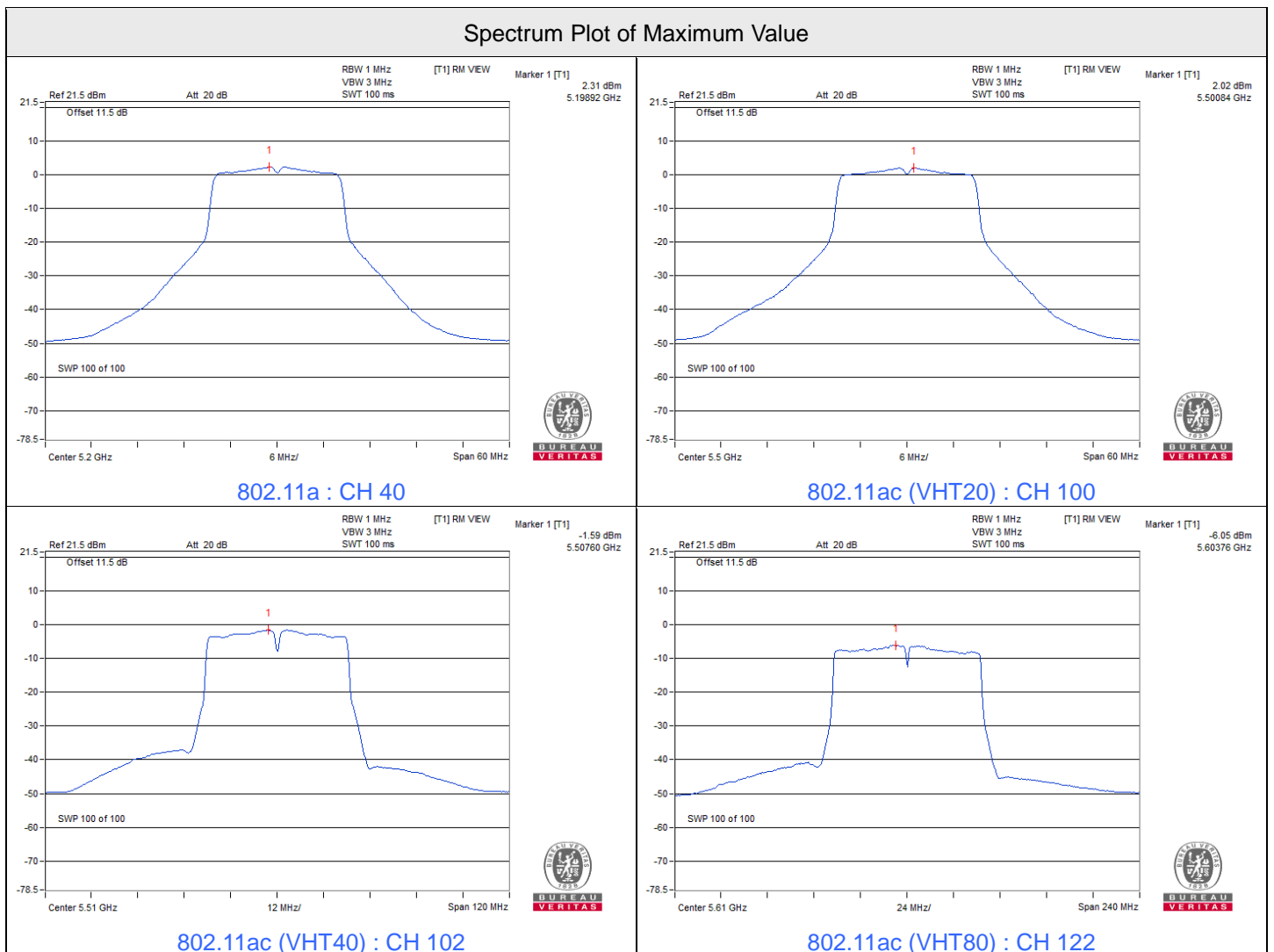



Spectrum Plot of Maximum Value

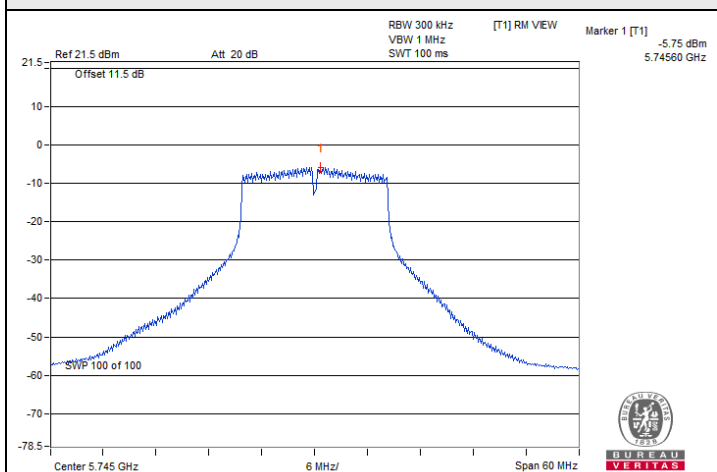

802.11a : CH 149

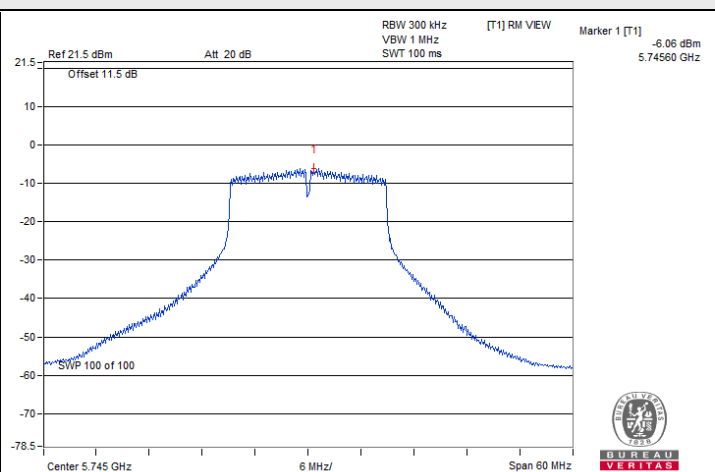

802.11ac (VHT20) : CH 149

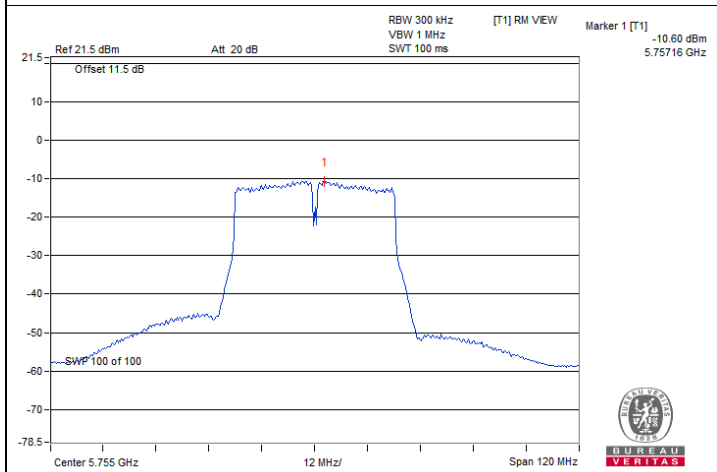

802.11ac (VHT40) : CH 151

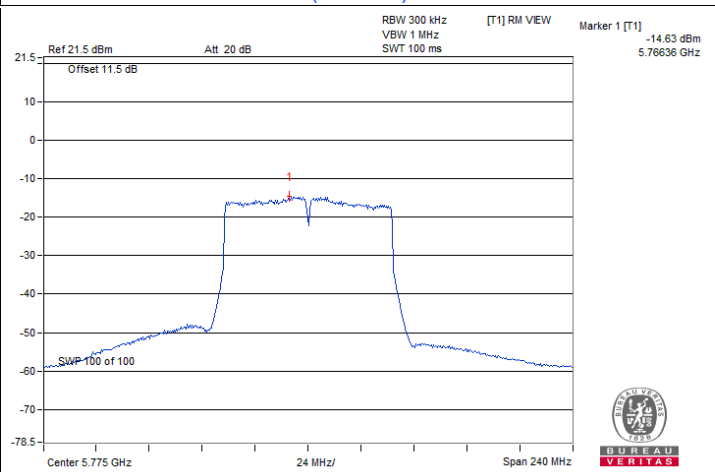

802.11ac (VHT80) : CH 155

7.4 6 dB Bandwidth

Input Power:	120 Vac, 60 Hz	Environmental Conditions:	25°C, 76% RH	Tested By:	Dalen Dai
--------------	----------------	---------------------------	--------------	------------	-----------

802.11a

Channel	Frequency (MHz)	6dB Bandwidth (MHz)	Minimum Limit (MHz)	Test Result
149	5745	15.85	0.5	Pass
157	5785	15.67	0.5	Pass
165	5825	15.84	0.5	Pass

802.11ac (VHT20)

Channel	Frequency (MHz)	6dB Bandwidth (MHz)	Minimum Limit (MHz)	Test Result
149	5745	16.07	0.5	Pass
157	5785	15.75	0.5	Pass
165	5825	15.38	0.5	Pass

802.11ac (VHT40)

Channel	Frequency (MHz)	6dB Bandwidth (MHz)	Minimum Limit (MHz)	Test Result
151	5755	36.12	0.5	Pass
159	5795	35.81	0.5	Pass

802.11ac (VHT80)

Channel	Frequency (MHz)	6dB Bandwidth (MHz)	Minimum Limit (MHz)	Test Result
155	5775	75.45	0.5	Pass



Spectrum Plot of Minimum Value

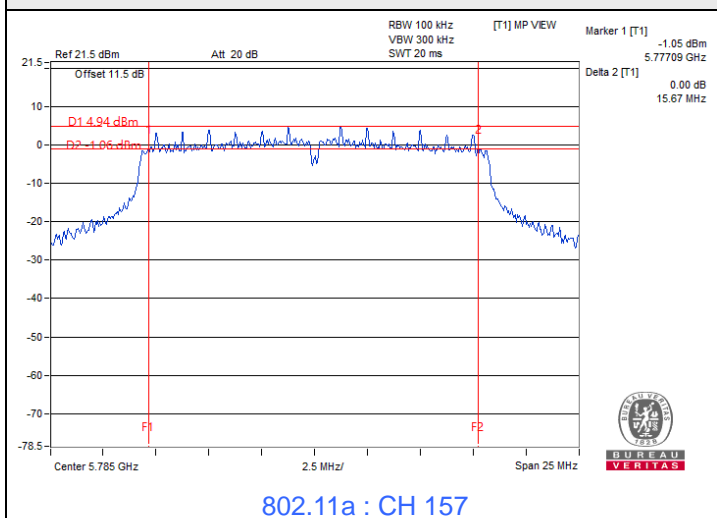

802.11a : CH 157

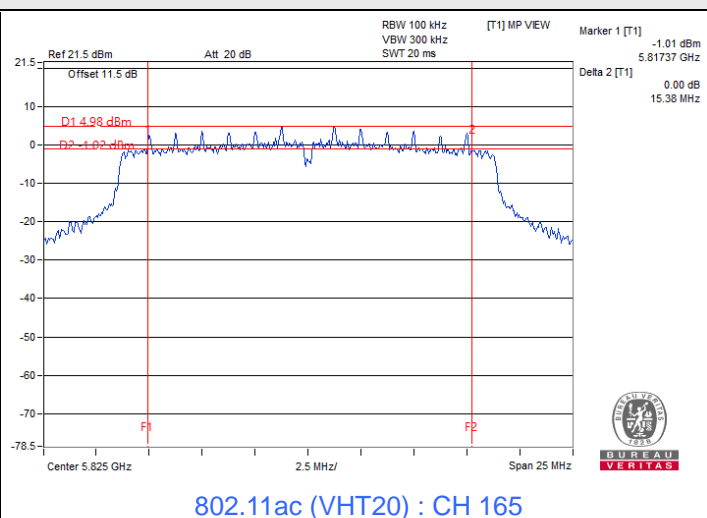

802.11ac (VHT20) : CH 165

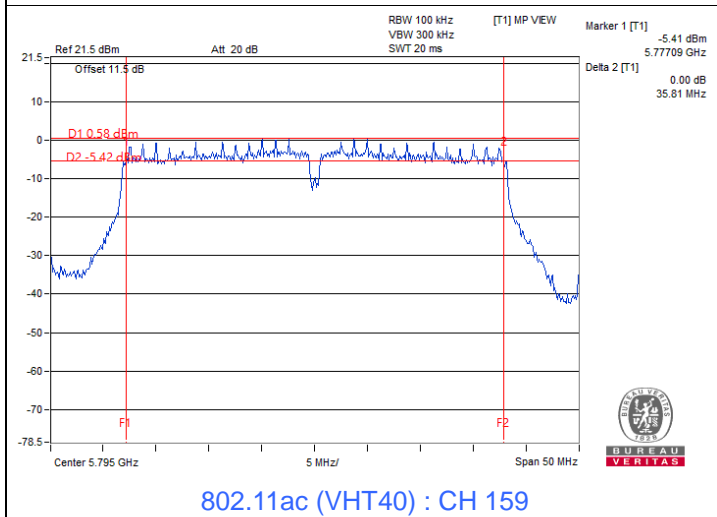

802.11ac (VHT40) : CH 159

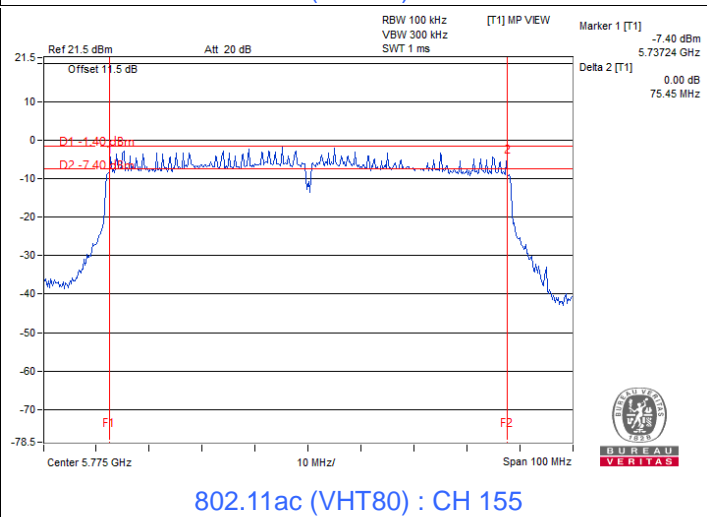

802.11ac (VHT80) : CH 155

7.5 Occupied Bandwidth

Input Power:	120 Vac, 60 Hz	Environmental Conditions:	25°C, 76% RH	Tested By:	Dalen Dai
--------------	----------------	---------------------------	--------------	------------	-----------

802.11a

Channel	Frequency (MHz)	Occupied Bandwidth (MHz)
36	5180	16.8
40	5200	16.8
48	5240	16.8
52	5260	16.92
60	5300	16.8
64	5320	16.8
100	5500	16.92
116	5580	16.92
140	5700	16.92
149	5745	16.92
157	5785	16.92
165	5825	16.8

802.11ac (VHT20)

Channel	Frequency (MHz)	Occupied Bandwidth (MHz)
36	5180	17.88
40	5200	18.12
48	5240	18
52	5260	18
60	5300	18
64	5320	18
100	5500	18
116	5580	17.88
140	5700	18.12
149	5745	17.88
157	5785	18
165	5825	17.88

802.11ac (VHT40)

Channel	Frequency (MHz)	Occupied Bandwidth (MHz)
38	5190	36.72
46	5230	36.48
54	5270	36.48
62	5310	36.72
102	5510	36.48
110	5550	36.48
134	5670	36.48
151	5755	36.72
159	5795	36.72

802.11ac (VHT80)

Channel	Frequency (MHz)	Occupied Bandwidth (MHz)
42	5210	76.8
58	5290	75.84
106	5530	75.84
122	5610	75.84
155	5775	76.32



Spectrum Plot of Maximum Value

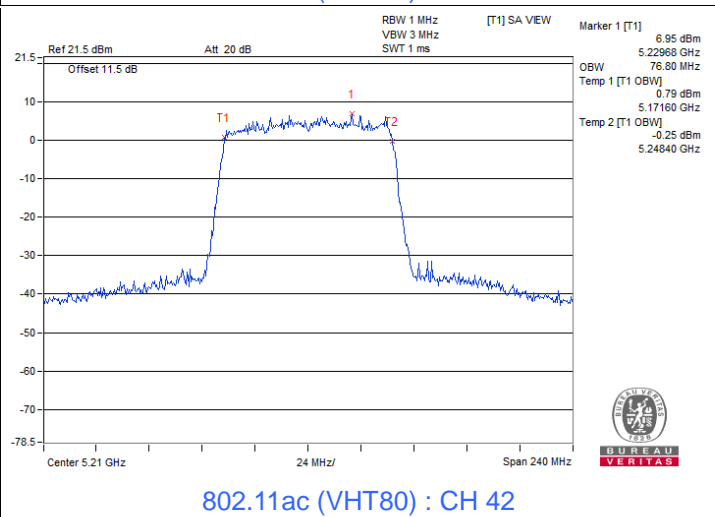
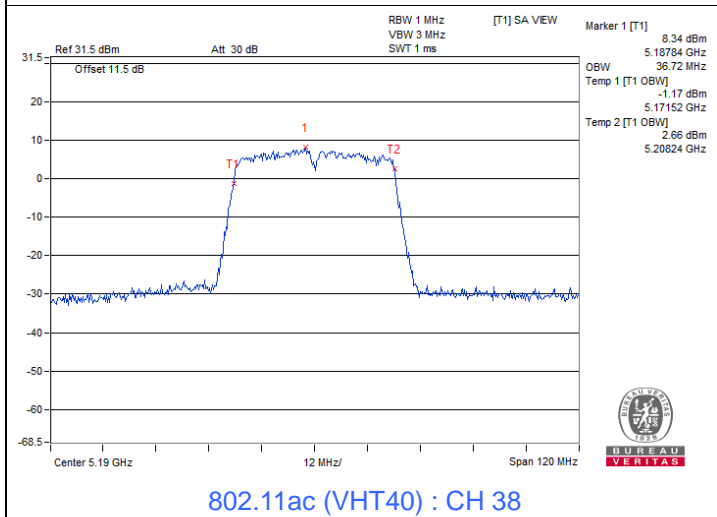
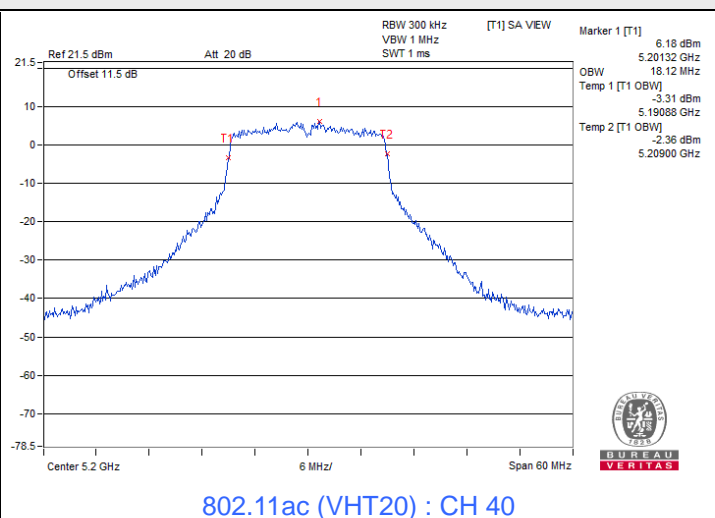
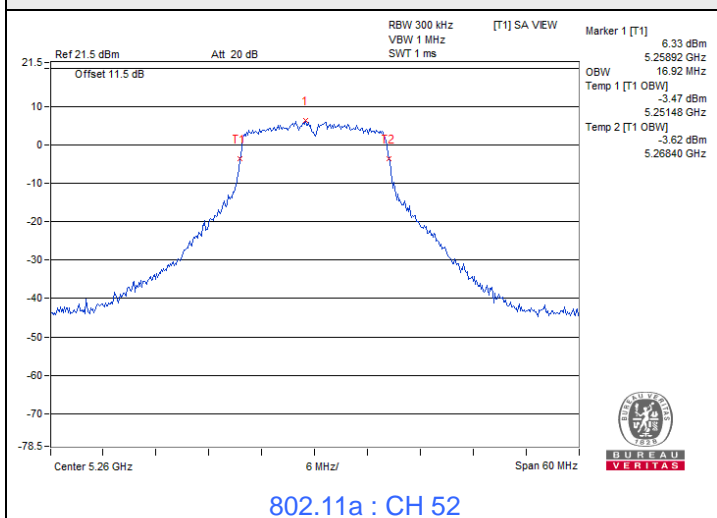



Spectrum Plot for nearby DFS band (DFS is required, if 99% OCP straddle into U-NII-2A)

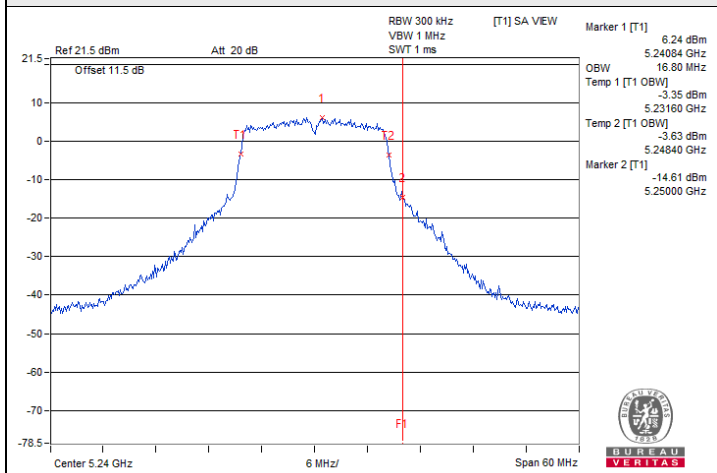

802.11a : CH 48

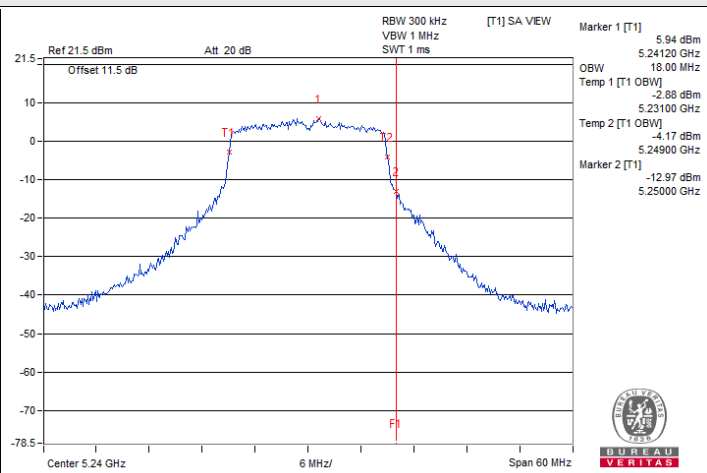

802.11a (VHT20) : CH 48

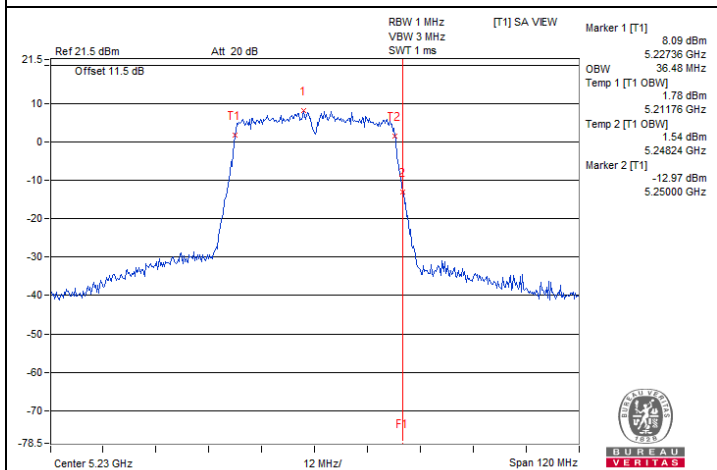

802.11ac (VHT40) : CH 46

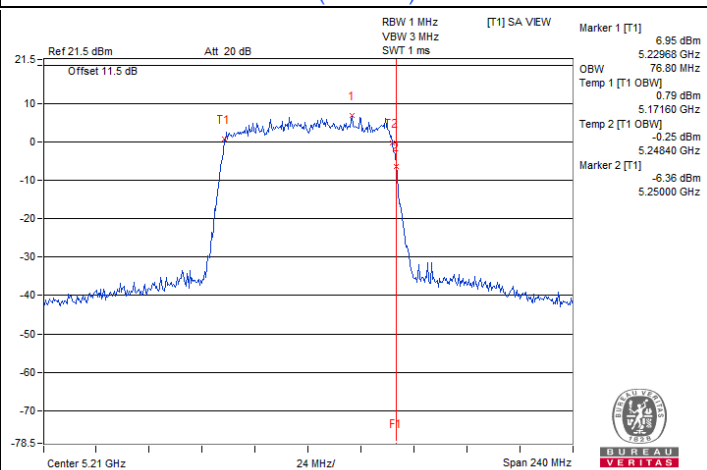

802.11ac (VHT80) : CH 42



Spectrum Plot for nearby DFS band (DFS is required, if 99% OCP straddle into U-NII-2C)

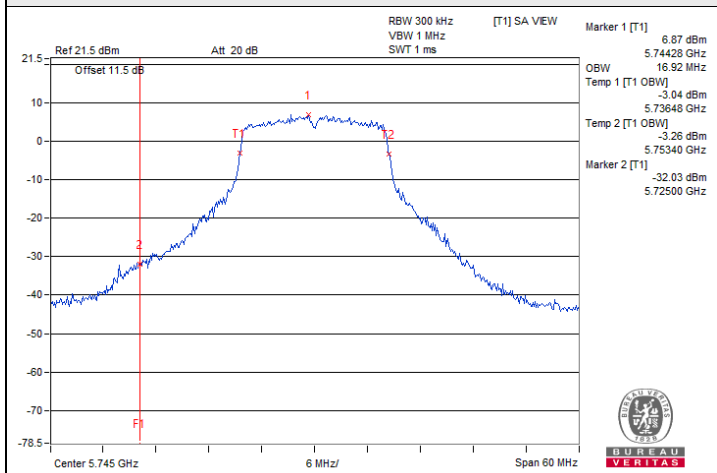

802.11a : CH 149

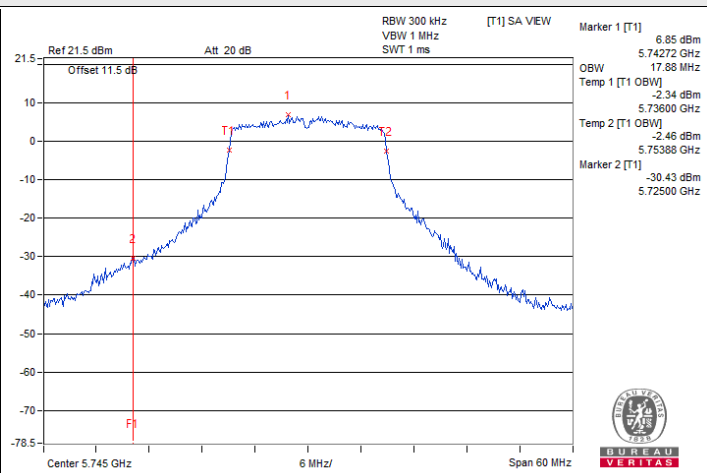

802.11ac (VHT20) : CH 149

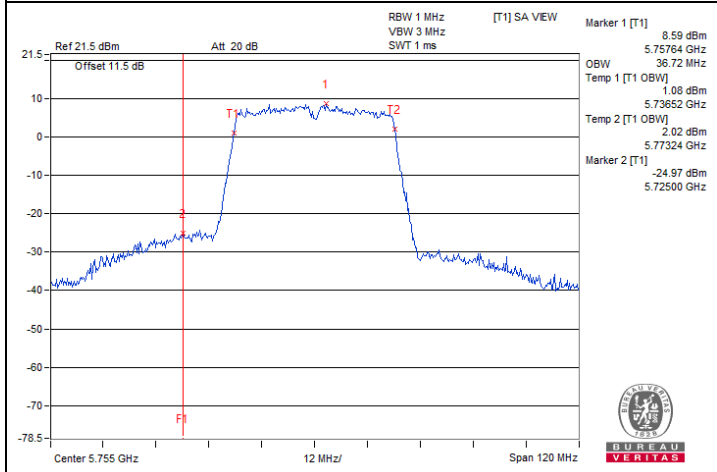

802.11ac (VHT40) : CH 151

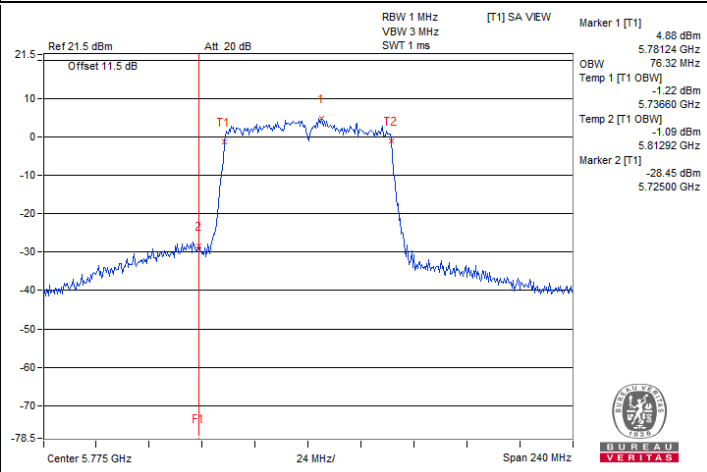

802.11ac (VHT80) : CH 155

7.6 Frequency Stability

Input Power:	120 Vac, 60 Hz	Environmental Conditions:	25°C, 76% RH	Tested By:	Dalen Dai
--------------	----------------	---------------------------	--------------	------------	-----------

802.11a

Frequency Stability Versus Temperature									
Operating Frequency: 5180 MHz									
Temp. (°C)	Power Supply (Vac)	0 Minute		2 Minutes		5 Minutes		10 Minutes	
		Measured Frequency (MHz)	Test Result	Measured Frequency (MHz)	Test Result	Measured Frequency (MHz)	Test Result	Measured Frequency (MHz)	Test Result
55	120	5180.0178	Pass	5180.0167	Pass	5180.0146	Pass	5180.0188	Pass
50	120	5180.0105	Pass	5180.0115	Pass	5180.015	Pass	5180.015	Pass
40	120	5180.0063	Pass	5180.009	Pass	5180.0061	Pass	5180.0073	Pass
30	120	5180.0176	Pass	5180.0194	Pass	5180.018	Pass	5180.0184	Pass
20	120	5179.9827	Pass	5179.9824	Pass	5179.9818	Pass	5179.9784	Pass
10	120	5179.9752	Pass	5179.9774	Pass	5179.9747	Pass	5179.9752	Pass
0	120	5179.9952	Pass	5179.9955	Pass	5179.997	Pass	5179.994	Pass
-10	120	5179.9956	Pass	5179.9965	Pass	5179.996	Pass	5179.9938	Pass
-20	120	5180.0044	Pass	5180.0012	Pass	5180.0031	Pass	5180.0026	Pass

Frequency Stability Versus Voltage									
Operating Frequency: 5180 MHz									
Temp. (°C)	Power Supply (Vac)	0 Minute		2 Minutes		5 Minutes		10 Minutes	
		Measured Frequency (MHz)	Test Result	Measured Frequency (MHz)	Test Result	Measured Frequency (MHz)	Test Result	Measured Frequency (MHz)	Test Result
20	138	5179.982	Pass	5179.9777	Pass	5179.9778	Pass	5179.9776	Pass
	120	5179.9827	Pass	5179.9824	Pass	5179.9818	Pass	5179.9784	Pass
	102	5179.9788	Pass	5179.9781	Pass	5179.9788	Pass	5179.9766	Pass

7.7 AC Power Conducted Emissions

RF Mode	802.11ac (VHT20)	Channel	CH 100 : 5500 MHz
Frequency Range	150kHz ~ 30MHz	Detector Function & Resolution Bandwidth	Quasi-Peak (QP) / Average (AV), 9 kHz
Input Power	120 Vac, 60 Hz	Environmental Conditions	25°C, 75% RH
Tested By	Jed Wu		

Phase Of Power : Line (L)										
No	Frequency (MHz)	Correction Factor (dB)	Reading Value (dBuV)		Emission Level (dBuV)		Limit (dBuV)		Margin (dB)	
			Q.P.	AV.	Q.P.	AV.	Q.P.	AV.	Q.P.	AV.
1	0.15719	10.00	27.24	12.36	37.24	22.36	65.61	55.61	-28.37	-33.25
2	0.41125	10.06	20.80	13.40	30.86	23.46	57.62	47.62	-26.76	-24.16
3	0.71896	10.08	22.93	17.95	33.01	28.03	56.00	46.00	-22.99	-17.97
4	4.08350	10.18	19.85	11.76	30.03	21.94	56.00	46.00	-25.97	-24.06
5	10.41006	10.35	26.57	18.63	36.92	28.98	60.00	50.00	-23.08	-21.02
6	15.78884	10.46	29.50	22.34	39.96	32.80	60.00	50.00	-20.04	-17.20

Remarks:

1. Q.P. and AV. are abbreviations of quasi-peak and average individually.
2. The emission levels of other frequencies were very low against the limit.
3. Margin value = Emission level – Limit value
4. Correction factor = Insertion loss + Cable loss
5. Emission Level = Correction Factor + Reading Value

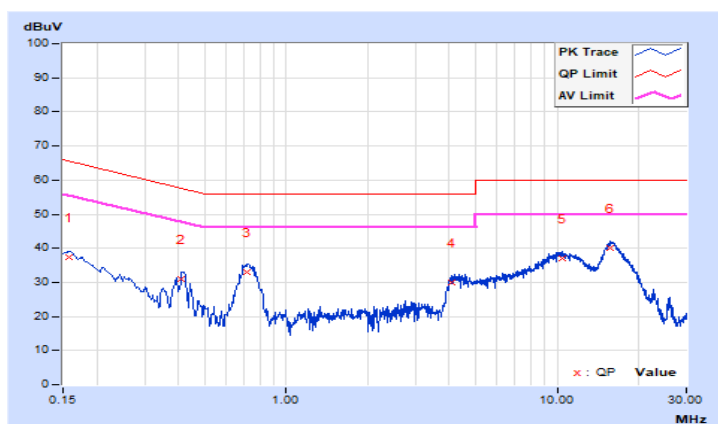

RF Mode	802.11ac (VHT20)	Channel	CH 100 : 5500 MHz
Frequency Range	150kHz ~ 30MHz	Detector Function & Resolution Bandwidth	Quasi-Peak (QP) / Average (AV), 9 kHz
Input Power	120 Vac, 60 Hz	Environmental Conditions	25°C, 75% RH
Tested By	Jed Wu		

Phase Of Power : Neutral (N)										
No	Frequency (MHz)	Correction Factor (dB)	Reading Value (dBuV)		Emission Level (dBuV)		Limit (dBuV)		Margin (dB)	
			Q.P.	AV.	Q.P.	AV.	Q.P.	AV.	Q.P.	AV.
1	0.15391	10.01	27.82	17.90	37.83	27.91	65.79	55.79	-27.96	-27.88
2	0.41190	10.06	21.19	14.97	31.25	25.03	57.61	47.61	-26.36	-22.58
3	0.73063	10.09	24.19	18.58	34.28	28.67	56.00	46.00	-21.72	-17.33
4	4.17731	10.19	20.07	13.01	30.26	23.20	56.00	46.00	-25.74	-22.80
5	9.86670	10.35	26.11	18.19	36.46	28.54	60.00	50.00	-23.54	-21.46
6	15.90611	10.47	29.94	22.94	40.41	33.41	60.00	50.00	-19.59	-16.59

Remarks:

1. Q.P. and AV. are abbreviations of quasi-peak and average individually.
2. The emission levels of other frequencies were very low against the limit.
3. Margin value = Emission level – Limit value
4. Correction factor = Insertion loss + Cable loss
5. Emission Level = Correction Factor + Reading Value

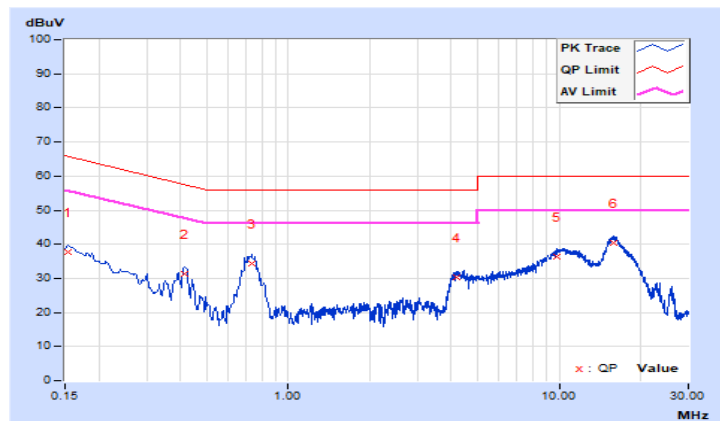

7.8 Unwanted Emissions below 1 GHz

RF Mode	802.11ac (VHT20)	Channel	CH 100 : 5500 MHz
Frequency Range	30 MHz ~ 1 GHz	Detector Function & Bandwidth	(QP) RB = 120kHz
Input Power	120 Vac, 60 Hz	Environmental Conditions	19°C, 60% RH
Tested By	Jed Wu		

Antenna Polarity & Test Distance : Horizontal at 3 m								
No	Frequency (MHz)	Emission Level (dBuV/m)	Limit (dBuV/m)	Margin (dB)	Antenna Height (m)	Table Angle (Degree)	Raw Value (dBuV)	Correction Factor (dB/m)
1	99.02	35.9 QP	43.5	-7.6	1.71 H	248	49.1	-13.2
2	132.00	33.6 QP	43.5	-9.9	1.82 H	119	43.4	-9.8
3	165.02	38.0 QP	43.5	-5.5	1.93 H	176	46.4	-8.4
4	375.03	36.3 QP	46.0	-9.7	1.47 H	314	40.7	-4.4
5	469.94	35.2 QP	46.0	-10.8	1.58 H	234	37.4	-2.2
6	561.46	34.3 QP	46.0	-11.7	1.69 H	223	34.8	-0.5

Remarks:

1. Emission Level(dBuV/m) = Raw Value(dBuV) + Correction Factor(dB/m)
2. Correction Factor(dB/m) = Antenna Factor(dB/m) + Cable Factor(dB) – Pre-Amplifier Factor(dB)
3. Margin value = Emission Level – Limit value
4. The other emission levels were very low against the limit of frequency range 30 MHz ~ 1 GHz.
5. The emission levels were very low against the limit of frequency range 9 kHz ~ 30 MHz: the amplitude of spurious emissions attenuated more than 20 dB below the permissible value to be report.

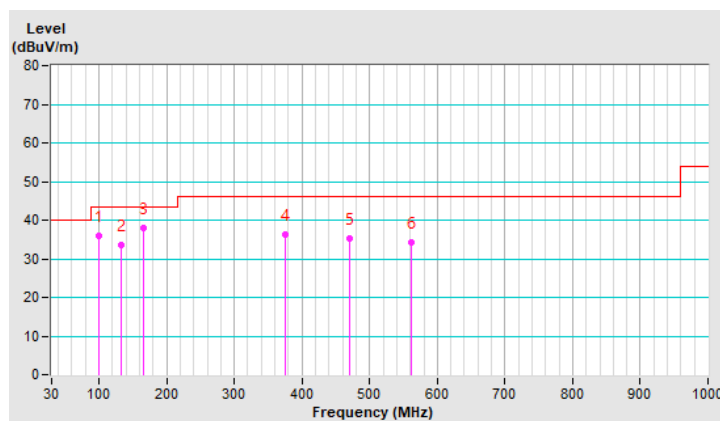

RF Mode	802.11ac (VHT20)	Channel	CH 100 : 5500 MHz
Frequency Range	30 MHz ~ 1 GHz	Detector Function & Bandwidth	(QP) RB = 120kHz
Input Power	120 Vac, 60 Hz	Environmental Conditions	19°C, 60% RH
Tested By	Jed Wu		

Antenna Polarity & Test Distance : Vertical at 3 m								
No	Frequency (MHz)	Emission Level (dBuV/m)	Limit (dBuV/m)	Margin (dB)	Antenna Height (m)	Table Angle (Degree)	Raw Value (dBuV)	Correction Factor (dB/m)
1	64.10	32.7 QP	40.0	-7.3	1.73 V	300	42.8	-10.1
2	132.04	35.5 QP	43.5	-8.0	1.91 V	38	45.3	-9.8
3	165.02	38.5 QP	43.5	-5.0	1.82 V	252	46.9	-8.4
4	383.52	31.4 QP	46.0	-14.6	1.46 V	147	35.7	-4.3
5	433.28	32.0 QP	46.0	-14.0	1.28 V	0	34.8	-2.8
6	500.45	30.5 QP	46.0	-15.5	1.64 V	197	32.2	-1.7

Remarks:

1. Emission Level(dBuV/m) = Raw Value(dBuV) + Correction Factor(dB/m)
2. Correction Factor(dB/m) = Antenna Factor(dB/m) + Cable Factor(dB) – Pre-Amplifier Factor(dB)
3. Margin value = Emission Level – Limit value
4. The other emission levels were very low against the limit of frequency range 30 MHz ~ 1 GHz.
5. The emission levels were very low against the limit of frequency range 9 kHz ~ 30 MHz: the amplitude of spurious emissions attenuated more than 20 dB below the permissible value to be report.

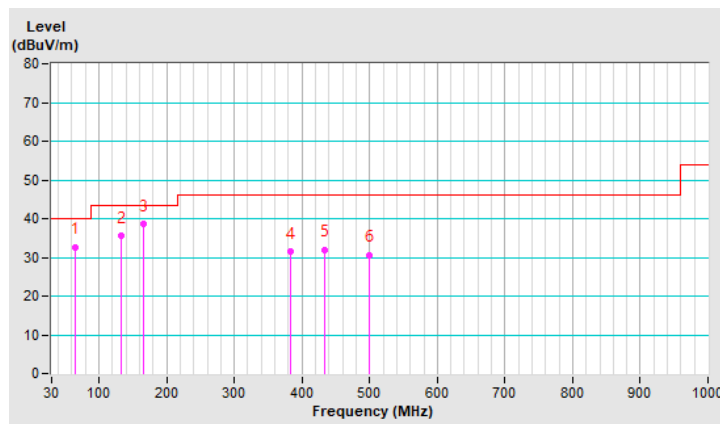

7.9 Unwanted Emissions above 1 GHz

RF Mode	802.11a	Channel	CH 36 : 5180 MHz
Frequency Range	1 GHz ~ 40 GHz	Detector Function & Bandwidth	(PK) RB = 1 MHz, VB = 3 MHz (AV) RB = 1 MHz, VB = 10 Hz
Input Power	120 Vac, 60 Hz	Environmental Conditions	20°C, 74% RH
Tested By	Jed Wu		

Antenna Polarity & Test Distance : Horizontal at 3 m

No	Frequency (MHz)	Emission Level (dBuV/m)	Limit (dBuV/m)	Margin (dB)	Antenna Height (m)	Table Angle (Degree)	Raw Value (dBuV)	Correction Factor (dB/m)
1	5150.00	59.1 PK	74.0	-14.9	1.22 H	315	51.6	7.5
2	5150.00	45.7 AV	54.0	-8.3	1.22 H	315	38.2	7.5
3	*5180.00	103.3 PK			1.22 H	315	95.8	7.5
4	*5180.00	92.8 AV			1.22 H	315	85.3	7.5
5	#10360.00	54.5 PK	68.2	-13.7	3.56 H	263	39.1	15.4

Antenna Polarity & Test Distance : Vertical at 3 m

No	Frequency (MHz)	Emission Level (dBuV/m)	Limit (dBuV/m)	Margin (dB)	Antenna Height (m)	Table Angle (Degree)	Raw Value (dBuV)	Correction Factor (dB/m)
1	5150.00	60.1 PK	74.0	-13.9	1.71 V	19	52.6	7.5
2	5150.00	46.6 AV	54.0	-7.4	1.71 V	19	39.1	7.5
3	*5180.00	107.5 PK			1.71 V	19	100.0	7.5
4	*5180.00	96.9 AV			1.71 V	19	89.4	7.5
5	#10360.00	55.3 PK	68.2	-12.9	2.31 V	102	39.9	15.4

Remarks:

1. Emission Level(dBuV/m) = Raw Value(dBuV) + Correction Factor(dB/m)
2. Correction Factor(dB/m) = Antenna Factor(dB/m) + Cable Factor(dB) – Pre-Amplifier Factor(dB)
3. Margin value = Emission Level – Limit value
4. The other emission levels were very low against the limit.
5. " * " : Fundamental frequency, the limit was restricted at the RF Output Power.
6. " # " : The radiated frequency is out of the restricted band.



RF Mode	802.11a	Channel	CH 40 : 5200 MHz
Frequency Range	1 GHz ~ 40 GHz	Detector Function & Bandwidth	(PK) RB = 1 MHz, VB = 3 MHz (AV) RB = 1 MHz, VB = 10 Hz
Input Power	120 Vac, 60 Hz	Environmental Conditions	20°C, 74% RH
Tested By	Jed Wu		

Antenna Polarity & Test Distance : Horizontal at 3 m

No	Frequency (MHz)	Emission Level (dBuV/m)	Limit (dBuV/m)	Margin (dB)	Antenna Height (m)	Table Angle (Degree)	Raw Value (dBuV)	Correction Factor (dB/m)
1	*5200.00	103.9 PK			1.23 H	304	96.4	7.5
2	*5200.00	93.6 AV			1.23 H	304	86.1	7.5
3	#10400.00	55.2 PK	68.2	-13.0	3.55 H	252	39.7	15.5

Antenna Polarity & Test Distance : Vertical at 3 m

No	Frequency (MHz)	Emission Level (dBuV/m)	Limit (dBuV/m)	Margin (dB)	Antenna Height (m)	Table Angle (Degree)	Raw Value (dBuV)	Correction Factor (dB/m)
1	*5200.00	108.1 PK			1.70 V	8	100.6	7.5
2	*5200.00	97.7 AV			1.70 V	8	90.2	7.5
3	#10400.00	56.0 PK	68.2	-12.2	2.32 V	90	40.5	15.5

Remarks:

1. Emission Level(dBuV/m) = Raw Value(dBuV) + Correction Factor(dB/m)
2. Correction Factor(dB/m) = Antenna Factor(dB/m) + Cable Factor(dB) – Pre-Amplifier Factor(dB)
3. Margin value = Emission Level – Limit value
4. The other emission levels were very low against the limit.
5. " * ": Fundamental frequency, the limit was restricted at the RF Output Power.
6. " # ": The radiated frequency is out of the restricted band.



RF Mode	802.11a	Channel	CH 48 : 5240 MHz
Frequency Range	1 GHz ~ 40 GHz	Detector Function & Bandwidth	(PK) RB = 1 MHz, VB = 3 MHz (AV) RB = 1 MHz, VB = 10 Hz
Input Power	120 Vac, 60 Hz	Environmental Conditions	20°C, 74% RH
Tested By	Jed Wu		

Antenna Polarity & Test Distance : Horizontal at 3 m

No	Frequency (MHz)	Emission Level (dBuV/m)	Limit (dBuV/m)	Margin (dB)	Antenna Height (m)	Table Angle (Degree)	Raw Value (dBuV)	Correction Factor (dB/m)
1	*5240.00	105.3 PK			1.05 H	316	97.4	7.9
2	*5240.00	95.2 AV			1.05 H	316	87.3	7.9
3	5350.00	59.1 PK	74.0	-14.9	1.05 H	316	50.5	8.6
4	5350.00	46.5 AV	54.0	-7.5	1.05 H	316	37.9	8.6
5	#10480.00	55.8 PK	68.2	-12.4	3.39 H	262	39.9	15.9

Antenna Polarity & Test Distance : Vertical at 3 m

No	Frequency (MHz)	Emission Level (dBuV/m)	Limit (dBuV/m)	Margin (dB)	Antenna Height (m)	Table Angle (Degree)	Raw Value (dBuV)	Correction Factor (dB/m)
1	*5240.00	108.7 PK			1.54 V	20	100.8	7.9
2	*5240.00	98.3 AV			1.54 V	20	90.4	7.9
3	5350.00	59.4 PK	74.0	-14.6	1.54 V	20	50.8	8.6
4	5350.00	46.7 AV	54.0	-7.3	1.54 V	20	38.1	8.6
5	#10480.00	56.6 PK	68.2	-11.6	2.48 V	103	40.7	15.9

Remarks:

1. Emission Level(dBuV/m) = Raw Value(dBuV) + Correction Factor(dB/m)
2. Correction Factor(dB/m) = Antenna Factor(dB/m) + Cable Factor(dB) – Pre-Amplifier Factor(dB)
3. Margin value = Emission Level – Limit value
4. The other emission levels were very low against the limit.
5. " * ": Fundamental frequency, the limit was restricted at the RF Output Power.
6. " # ": The radiated frequency is out of the restricted band.



RF Mode	802.11a	Channel	CH 52 : 5260 MHz
Frequency Range	1 GHz ~ 40 GHz	Detector Function & Bandwidth	(PK) RB = 1 MHz, VB = 3 MHz (AV) RB = 1 MHz, VB = 10 Hz
Input Power	120 Vac, 60 Hz	Environmental Conditions	20°C, 74% RH
Tested By	Jed Wu		

Antenna Polarity & Test Distance : Horizontal at 3 m

No	Frequency (MHz)	Emission Level (dBuV/m)	Limit (dBuV/m)	Margin (dB)	Antenna Height (m)	Table Angle (Degree)	Raw Value (dBuV)	Correction Factor (dB/m)
1	5150.00	58.7 PK	74.0	-15.3	1.44 H	312	51.2	7.5
2	5150.00	45.5 AV	54.0	-8.5	1.44 H	312	38.0	7.5
3	*5260.00	105.0 PK			1.44 H	312	96.9	8.1
4	*5260.00	94.6 AV			1.44 H	312	86.5	8.1
5	#10520.00	55.6 PK	68.2	-12.6	3.34 H	260	39.6	16.0

Antenna Polarity & Test Distance : Vertical at 3 m

No	Frequency (MHz)	Emission Level (dBuV/m)	Limit (dBuV/m)	Margin (dB)	Antenna Height (m)	Table Angle (Degree)	Raw Value (dBuV)	Correction Factor (dB/m)
1	5150.00	59.0 PK	74.0	-15.0	1.93 V	22	51.5	7.5
2	5150.00	45.8 AV	54.0	-8.2	1.93 V	22	38.3	7.5
3	*5260.00	108.6 PK			1.93 V	22	100.5	8.1
4	*5260.00	98.2 AV			1.93 V	22	90.1	8.1
5	#10520.00	56.4 PK	68.2	-11.8	2.53 V	105	40.4	16.0

Remarks:

1. Emission Level(dBuV/m) = Raw Value(dBuV) + Correction Factor(dB/m)
2. Correction Factor(dB/m) = Antenna Factor(dB/m) + Cable Factor(dB) – Pre-Amplifier Factor(dB)
3. Margin value = Emission Level – Limit value
4. The other emission levels were very low against the limit.
5. " * " : Fundamental frequency, the limit was restricted at the RF Output Power.
6. " # " : The radiated frequency is out of the restricted band.



RF Mode	802.11a	Channel	CH 60 : 5300 MHz
Frequency Range	1 GHz ~ 40 GHz	Detector Function & Bandwidth	(PK) RB = 1 MHz, VB = 3 MHz (AV) RB = 1 MHz, VB = 10 Hz
Input Power	120 Vac, 60 Hz	Environmental Conditions	20°C, 74% RH
Tested By	Jed Wu		

Antenna Polarity & Test Distance : Horizontal at 3 m

No	Frequency (MHz)	Emission Level (dBuV/m)	Limit (dBuV/m)	Margin (dB)	Antenna Height (m)	Table Angle (Degree)	Raw Value (dBuV)	Correction Factor (dB/m)
1	*5300.00	105.9 PK			1.49 H	318	97.5	8.4
2	*5300.00	95.4 AV			1.49 H	318	87.0	8.4
3	10600.00	54.4 PK	74.0	-19.6	3.29 H	266	38.3	16.1
4	10600.00	41.7 AV	54.0	-12.3	3.29 H	266	25.6	16.1

Antenna Polarity & Test Distance : Vertical at 3 m

No	Frequency (MHz)	Emission Level (dBuV/m)	Limit (dBuV/m)	Margin (dB)	Antenna Height (m)	Table Angle (Degree)	Raw Value (dBuV)	Correction Factor (dB/m)
1	*5300.00	110.1 PK			1.44 V	16	101.7	8.4
2	*5300.00	99.6 AV			1.44 V	16	91.2	8.4
3	10600.00	55.2 PK	74.0	-18.8	2.04 V	105	39.1	16.1
4	10600.00	42.5 AV	54.0	-11.5	2.04 V	105	26.4	16.1

Remarks:

1. Emission Level(dBuV/m) = Raw Value(dBuV) + Correction Factor(dB/m)
2. Correction Factor(dB/m) = Antenna Factor(dB/m) + Cable Factor(dB) – Pre-Amplifier Factor(dB)
3. Margin value = Emission Level – Limit value
4. The other emission levels were very low against the limit.
5. " * " : Fundamental frequency, the limit was restricted at the RF Output Power.



RF Mode	802.11a	Channel	CH 64 : 5320 MHz
Frequency Range	1 GHz ~ 40 GHz	Detector Function & Bandwidth	(PK) RB = 1 MHz, VB = 3 MHz (AV) RB = 1 MHz, VB = 10 Hz
Input Power	120 Vac, 60 Hz	Environmental Conditions	20°C, 74% RH
Tested By	Jed Wu		

Antenna Polarity & Test Distance : Horizontal at 3 m

No	Frequency (MHz)	Emission Level (dBuV/m)	Limit (dBuV/m)	Margin (dB)	Antenna Height (m)	Table Angle (Degree)	Raw Value (dBuV)	Correction Factor (dB/m)
1	*5320.00	106.6 PK			1.34 H	320	98.1	8.5
2	*5320.00	96.4 AV			1.34 H	320	87.9	8.5
3	5350.00	60.5 PK	74.0	-13.5	1.34 H	320	51.9	8.6
4	5350.00	46.8 AV	54.0	-7.2	1.34 H	320	38.2	8.6
5	10640.00	54.7 PK	74.0	-19.3	3.43 H	264	38.7	16.0
6	10640.00	42.0 AV	54.0	-12.0	3.43 H	264	26.0	16.0

Antenna Polarity & Test Distance : Vertical at 3 m

No	Frequency (MHz)	Emission Level (dBuV/m)	Limit (dBuV/m)	Margin (dB)	Antenna Height (m)	Table Angle (Degree)	Raw Value (dBuV)	Correction Factor (dB/m)
1	*5320.00	110.6 PK			1.59 V	18	102.1	8.5
2	*5320.00	100.0 AV			1.59 V	18	91.5	8.5
3	5350.00	60.8 PK	74.0	-13.2	1.59 V	18	52.2	8.6
4	5350.00	47.1 AV	54.0	-6.9	1.59 V	18	38.5	8.6
5	10640.00	55.5 PK	74.0	-18.5	1.88 V	107	39.5	16.0
6	10640.00	42.8 AV	54.0	-11.2	1.88 V	107	26.8	16.0

Remarks:

1. Emission Level(dBuV/m) = Raw Value(dBuV) + Correction Factor(dB/m)
2. Correction Factor(dB/m) = Antenna Factor(dB/m) + Cable Factor(dB) – Pre-Amplifier Factor(dB)
3. Margin value = Emission Level – Limit value
4. The other emission levels were very low against the limit.
5. " * ": Fundamental frequency, the limit was restricted at the RF Output Power.



RF Mode	802.11a	Channel	CH 100 : 5500 MHz
Frequency Range	1 GHz ~ 40 GHz	Detector Function & Bandwidth	(PK) RB = 1 MHz, VB = 3 MHz (AV) RB = 1 MHz, VB = 10 Hz
Input Power	120 Vac, 60 Hz	Environmental Conditions	20°C, 74% RH
Tested By	Jed Wu		

Antenna Polarity & Test Distance : Horizontal at 3 m

No	Frequency (MHz)	Emission Level (dBuV/m)	Limit (dBuV/m)	Margin (dB)	Antenna Height (m)	Table Angle (Degree)	Raw Value (dBuV)	Correction Factor (dB/m)
1	5460.00	60.1 PK	74.0	-13.9	1.42 H	305	51.3	8.8
2	5460.00	46.9 AV	54.0	-7.1	1.42 H	305	38.1	8.8
3	#5470.00	60.9 PK	68.2	-7.3	1.42 H	305	52.1	8.8
4	*5500.00	110.2 PK			1.42 H	305	101.3	8.9
5	*5500.00	99.8 AV			1.42 H	305	90.9	8.9
6	11000.00	56.9 PK	74.0	-17.1	3.00 H	268	40.0	16.9
7	11000.00	44.2 AV	54.0	-9.8	3.00 H	268	27.3	16.9

Antenna Polarity & Test Distance : Vertical at 3 m

No	Frequency (MHz)	Emission Level (dBuV/m)	Limit (dBuV/m)	Margin (dB)	Antenna Height (m)	Table Angle (Degree)	Raw Value (dBuV)	Correction Factor (dB/m)
1	5460.00	61.9 PK	74.0	-12.1	1.67 V	4	53.1	8.8
2	5460.00	48.0 AV	54.0	-6.0	1.67 V	4	39.2	8.8
3	#5470.00	63.1 PK	68.2	-5.1	1.67 V	4	54.3	8.8
4	*5500.00	113.2 PK			1.67 V	4	104.3	8.9
5	*5500.00	102.8 AV			1.67 V	4	93.9	8.9
6	11000.00	57.3 PK	74.0	-16.7	2.27 V	92	40.4	16.9
7	11000.00	44.6 AV	54.0	-9.4	2.27 V	92	27.7	16.9

Remarks:

1. Emission Level(dBuV/m) = Raw Value(dBuV) + Correction Factor(dB/m)
2. Correction Factor(dB/m) = Antenna Factor(dB/m) + Cable Factor(dB) – Pre-Amplifier Factor(dB)
3. Margin value = Emission Level – Limit value
4. The other emission levels were very low against the limit.
5. " * " : Fundamental frequency, the limit was restricted at the RF Output Power.
6. " # " : The radiated frequency is out of the restricted band.



RF Mode	802.11a	Channel	CH 116 : 5580 MHz
Frequency Range	1 GHz ~ 40 GHz	Detector Function & Bandwidth	(PK) RB = 1 MHz, VB = 3 MHz (AV) RB = 1 MHz, VB = 10 Hz
Input Power	120 Vac, 60 Hz	Environmental Conditions	20°C, 74% RH
Tested By	Jed Wu		

Antenna Polarity & Test Distance : Horizontal at 3 m

No	Frequency (MHz)	Emission Level (dBuV/m)	Limit (dBuV/m)	Margin (dB)	Antenna Height (m)	Table Angle (Degree)	Raw Value (dBuV)	Correction Factor (dB/m)
1	*5580.00	108.1 PK			1.44 H	331	99.5	8.6
2	*5580.00	97.7 AV			1.44 H	331	89.1	8.6
3	11160.00	57.2 PK	74.0	-16.8	2.98 H	242	40.2	17.0
4	11160.00	44.5 AV	54.0	-9.5	2.98 H	242	27.5	17.0

Antenna Polarity & Test Distance : Vertical at 3 m

No	Frequency (MHz)	Emission Level (dBuV/m)	Limit (dBuV/m)	Margin (dB)	Antenna Height (m)	Table Angle (Degree)	Raw Value (dBuV)	Correction Factor (dB/m)
1	*5580.00	110.9 PK			1.65 V	30	102.3	8.6
2	*5580.00	100.4 AV			1.65 V	30	91.8	8.6
3	11160.00	57.6 PK	74.0	-16.4	2.29 V	118	40.6	17.0
4	11160.00	44.9 AV	54.0	-9.1	2.29 V	118	27.9	17.0

Remarks:

1. Emission Level(dBuV/m) = Raw Value(dBuV) + Correction Factor(dB/m)
2. Correction Factor(dB/m) = Antenna Factor(dB/m) + Cable Factor(dB) – Pre-Amplifier Factor(dB)
3. Margin value = Emission Level – Limit value
4. The other emission levels were very low against the limit.
5. " * ": Fundamental frequency, the limit was restricted at the RF Output Power.



RF Mode	802.11a	Channel	CH 140 : 5700 MHz
Frequency Range	1 GHz ~ 40 GHz	Detector Function & Bandwidth	(PK) RB = 1 MHz, VB = 3 MHz (AV) RB = 1 MHz, VB = 10 Hz
Input Power	120 Vac, 60 Hz	Environmental Conditions	20°C, 74% RH
Tested By	Jed Wu		

Antenna Polarity & Test Distance : Horizontal at 3 m

No	Frequency (MHz)	Emission Level (dBuV/m)	Limit (dBuV/m)	Margin (dB)	Antenna Height (m)	Table Angle (Degree)	Raw Value (dBuV)	Correction Factor (dB/m)
1	*5700.00	106.8 PK			1.62 H	327	98.7	8.1
2	*5700.00	96.5 AV			1.62 H	327	88.4	8.1
3	#5725.00	59.8 PK	68.2	-8.4	1.62 H	327	51.7	8.1
4	11400.00	57.6 PK	74.0	-16.4	2.80 H	246	40.0	17.6
5	11400.00	45.0 AV	54.0	-9.0	2.80 H	246	27.4	17.6

Antenna Polarity & Test Distance : Vertical at 3 m

No	Frequency (MHz)	Emission Level (dBuV/m)	Limit (dBuV/m)	Margin (dB)	Antenna Height (m)	Table Angle (Degree)	Raw Value (dBuV)	Correction Factor (dB/m)
1	*5700.00	109.5 PK			1.87 V	342	101.4	8.1
2	*5700.00	99.0 AV			1.87 V	342	90.9	8.1
3	#5725.00	60.7 PK	68.2	-7.5	1.87 V	342	52.6	8.1
4	11400.00	58.1 PK	74.0	-15.9	2.51 V	166	40.5	17.6
5	11400.00	45.4 AV	54.0	-8.6	2.51 V	166	27.8	17.6

Remarks:

1. Emission Level(dBuV/m) = Raw Value(dBuV) + Correction Factor(dB/m)
2. Correction Factor(dB/m) = Antenna Factor(dB/m) + Cable Factor(dB) – Pre-Amplifier Factor(dB)
3. Margin value = Emission Level – Limit value
4. The other emission levels were very low against the limit.
5. " * " : Fundamental frequency, the limit was restricted at the RF Output Power.
6. " # " : The radiated frequency is out of the restricted band.



RF Mode	802.11a	Channel	CH 149 : 5745 MHz
Frequency Range	1 GHz ~ 40 GHz	Detector Function & Bandwidth	(PK) RB = 1 MHz, VB = 3 MHz (AV) RB = 1 MHz, VB = 10 Hz
Input Power	120 Vac, 60 Hz	Environmental Conditions	20°C, 74% RH
Tested By	Jed Wu		

Antenna Polarity & Test Distance : Horizontal at 3 m

No	Frequency (MHz)	Emission Level (dBuV/m)	Limit (dBuV/m)	Margin (dB)	Antenna Height (m)	Table Angle (Degree)	Raw Value (dBuV)	Correction Factor (dB/m)
1	#5633.12	58.7 PK	68.2	-9.5	2.09 H	293	50.4	8.3
2	*5745.00	108.2 PK			2.09 H	293	100.2	8.0
3	*5745.00	97.8 AV			2.09 H	293	89.8	8.0
4	#6018.35	59.4 PK	68.2	-8.8	2.09 H	293	50.9	8.5
5	11490.00	57.5 PK	74.0	-16.5	2.33 H	256	40.5	17.0
6	11490.00	44.8 AV	54.0	-9.2	2.33 H	256	27.8	17.0

Antenna Polarity & Test Distance : Vertical at 3 m

No	Frequency (MHz)	Emission Level (dBuV/m)	Limit (dBuV/m)	Margin (dB)	Antenna Height (m)	Table Angle (Degree)	Raw Value (dBuV)	Correction Factor (dB/m)
1	#5608.90	59.2 PK	68.2	-9.0	1.00 V	352	50.8	8.4
2	*5745.00	110.8 PK			1.00 V	352	102.8	8.0
3	*5745.00	100.4 AV			1.00 V	352	92.4	8.0
4	#5983.68	59.9 PK	68.2	-8.3	1.00 V	352	51.5	8.4
5	11490.00	57.9 PK	74.0	-16.1	1.60 V	80	40.9	17.0
6	11490.00	45.2 AV	54.0	-8.8	1.60 V	80	28.2	17.0

Remarks:

1. Emission Level(dBuV/m) = Raw Value(dBuV) + Correction Factor(dB/m)
2. Correction Factor(dB/m) = Antenna Factor(dB/m) + Cable Factor(dB) – Pre-Amplifier Factor(dB)
3. Margin value = Emission Level – Limit value
4. The other emission levels were very low against the limit.
5. " * ": Fundamental frequency, the limit was restricted at the RF Output Power.



RF Mode	802.11a	Channel	CH 157 : 5785 MHz
Frequency Range	1 GHz ~ 40 GHz	Detector Function & Bandwidth	(PK) RB = 1 MHz, VB = 3 MHz (AV) RB = 1 MHz, VB = 10 Hz
Input Power	120 Vac, 60 Hz	Environmental Conditions	20°C, 74% RH
Tested By	Jed Wu		

Antenna Polarity & Test Distance : Horizontal at 3 m

No	Frequency (MHz)	Emission Level (dBuV/m)	Limit (dBuV/m)	Margin (dB)	Antenna Height (m)	Table Angle (Degree)	Raw Value (dBuV)	Correction Factor (dB/m)
1	#5639.77	58.6 PK	68.2	-9.6	2.03 H	294	50.4	8.2
2	*5785.00	108.7 PK			2.03 H	294	100.7	8.0
3	*5785.00	98.3 AV			2.03 H	294	90.3	8.0
4	#5964.68	59.4 PK	68.2	-8.8	2.03 H	294	51.1	8.3
5	11570.00	58.2 PK	74.0	-15.8	2.39 H	257	40.7	17.5
6	11570.00	45.5 AV	54.0	-8.5	2.39 H	257	28.0	17.5

Antenna Polarity & Test Distance : Vertical at 3 m

No	Frequency (MHz)	Emission Level (dBuV/m)	Limit (dBuV/m)	Margin (dB)	Antenna Height (m)	Table Angle (Degree)	Raw Value (dBuV)	Correction Factor (dB/m)
1	#5641.68	59.2 PK	68.2	-9.0	1.06 V	353	51.1	8.1
2	*5785.00	111.6 PK			1.06 V	353	103.6	8.0
3	*5785.00	101.5 AV			1.06 V	353	93.5	8.0
4	#5984.62	60.2 PK	68.2	-8.0	1.06 V	353	51.8	8.4
5	11570.00	58.6 PK	74.0	-15.4	1.66 V	81	41.1	17.5
6	11570.00	45.9 AV	54.0	-8.1	1.66 V	81	28.4	17.5

Remarks:

1. Emission Level(dBuV/m) = Raw Value(dBuV) + Correction Factor(dB/m)
2. Correction Factor(dB/m) = Antenna Factor(dB/m) + Cable Factor(dB) – Pre-Amplifier Factor(dB)
3. Margin value = Emission Level – Limit value
4. The other emission levels were very low against the limit.
5. " * " : Fundamental frequency, the limit was restricted at the RF Output Power.
6. " # " : The radiated frequency is out of the restricted band.



RF Mode	802.11a	Channel	CH 165 : 5825 MHz
Frequency Range	1 GHz ~ 40 GHz	Detector Function & Bandwidth	(PK) RB = 1 MHz, VB = 3 MHz (AV) RB = 1 MHz, VB = 10 Hz
Input Power	120 Vac, 60 Hz	Environmental Conditions	20°C, 74% RH
Tested By	Jed Wu		

Antenna Polarity & Test Distance : Horizontal at 3 m

No	Frequency (MHz)	Emission Level (dBuV/m)	Limit (dBuV/m)	Margin (dB)	Antenna Height (m)	Table Angle (Degree)	Raw Value (dBuV)	Correction Factor (dB/m)
1	#5607.00	59.1 PK	68.2	-9.1	2.03 H	295	50.7	8.4
2	*5825.00	109.2 PK			2.03 H	295	101.2	8.0
3	*5825.00	99.0 AV			2.03 H	295	91.0	8.0
4	#6005.05	59.8 PK	68.2	-8.4	2.03 H	295	51.5	8.3
5	11650.00	58.1 PK	74.0	-15.9	2.39 H	256	40.1	18.0
6	11650.00	45.4 AV	54.0	-8.6	2.39 H	256	27.4	18.0

Antenna Polarity & Test Distance : Vertical at 3 m

No	Frequency (MHz)	Emission Level (dBuV/m)	Limit (dBuV/m)	Margin (dB)	Antenna Height (m)	Table Angle (Degree)	Raw Value (dBuV)	Correction Factor (dB/m)
1	#5645.00	59.7 PK	68.2	-8.5	1.05 V	355	51.6	8.1
2	*5825.00	112.3 PK			1.05 V	355	104.3	8.0
3	*5825.00	102.0 AV			1.05 V	355	94.0	8.0
4	#6009.80	59.7 PK	68.2	-8.5	1.05 V	355	51.3	8.4
5	11650.00	58.5 PK	74.0	-15.5	1.65 V	83	40.5	18.0
6	11650.00	45.8 AV	54.0	-8.2	1.65 V	83	27.8	18.0

Remarks:

1. Emission Level(dBuV/m) = Raw Value(dBuV) + Correction Factor(dB/m)
2. Correction Factor(dB/m) = Antenna Factor(dB/m) + Cable Factor(dB) – Pre-Amplifier Factor(dB)
3. Margin value = Emission Level – Limit value
4. The other emission levels were very low against the limit.
5. " * " : Fundamental frequency, the limit was restricted at the RF Output Power.
6. " # " : The radiated frequency is out of the restricted band.

RF Mode	802.11ac (VHT20)	Channel	CH 36 : 5180 MHz
Frequency Range	1 GHz ~ 40 GHz	Detector Function & Bandwidth	(PK) RB = 1 MHz, VB = 3 MHz (AV) RB = 1 MHz, VB = 10 Hz
Input Power	120 Vac, 60 Hz	Environmental Conditions	20°C, 74% RH
Tested By	Jed Wu		

Antenna Polarity & Test Distance : Horizontal at 3 m

No	Frequency (MHz)	Emission Level (dBuV/m)	Limit (dBuV/m)	Margin (dB)	Antenna Height (m)	Table Angle (Degree)	Raw Value (dBuV)	Correction Factor (dB/m)
1	5150.00	59.7 PK	74.0	-14.3	1.82 H	303	52.2	7.5
2	5150.00	46.1 AV	54.0	-7.9	1.82 H	303	38.6	7.5
3	*5180.00	103.7 PK			1.82 H	303	96.2	7.5
4	*5180.00	93.5 AV			1.82 H	303	86.0	7.5
5	#10360.00	54.6 PK	68.2	-13.6	2.96 H	251	39.2	15.4

Antenna Polarity & Test Distance : Vertical at 3 m

No	Frequency (MHz)	Emission Level (dBuV/m)	Limit (dBuV/m)	Margin (dB)	Antenna Height (m)	Table Angle (Degree)	Raw Value (dBuV)	Correction Factor (dB/m)
1	5150.00	60.1 PK	74.0	-13.9	1.11 V	7	52.6	7.5
2	5150.00	46.5 AV	54.0	-7.5	1.11 V	7	39.0	7.5
3	*5180.00	107.7 PK			1.11 V	7	100.2	7.5
4	*5180.00	97.2 AV			1.11 V	7	89.7	7.5
5	#10360.00	55.5 PK	68.2	-12.7	1.72 V	90	40.1	15.4

Remarks:

1. Emission Level(dBuV/m) = Raw Value(dBuV) + Correction Factor(dB/m)
2. Correction Factor(dB/m) = Antenna Factor(dB/m) + Cable Factor(dB) – Pre-Amplifier Factor(dB)
3. Margin value = Emission Level – Limit value
4. The other emission levels were very low against the limit.
5. " * ": Fundamental frequency, the limit was restricted at the RF Output Power.
6. " # ": The radiated frequency is out of the restricted band.



RF Mode	802.11ac (VHT20)	Channel	CH 40 : 5200 MHz
Frequency Range	1 GHz ~ 40 GHz	Detector Function & Bandwidth	(PK) RB = 1 MHz, VB = 3 MHz (AV) RB = 1 MHz, VB = 10 Hz
Input Power	120 Vac, 60 Hz	Environmental Conditions	20°C, 74% RH
Tested By	Jed Wu		

Antenna Polarity & Test Distance : Horizontal at 3 m

No	Frequency (MHz)	Emission Level (dBuV/m)	Limit (dBuV/m)	Margin (dB)	Antenna Height (m)	Table Angle (Degree)	Raw Value (dBuV)	Correction Factor (dB/m)
1	*5200.00	103.0 PK			1.29 H	302	95.5	7.5
2	*5200.00	92.5 AV			1.29 H	302	85.0	7.5
3	#10400.00	54.3 PK	68.2	-13.9	3.49 H	251	38.8	15.5

Antenna Polarity & Test Distance : Vertical at 3 m

No	Frequency (MHz)	Emission Level (dBuV/m)	Limit (dBuV/m)	Margin (dB)	Antenna Height (m)	Table Angle (Degree)	Raw Value (dBuV)	Correction Factor (dB/m)
1	*5200.00	107.2 PK			1.78 V	6	99.7	7.5
2	*5200.00	96.6 AV			1.78 V	6	89.1	7.5
3	#10400.00	55.1 PK	68.2	-13.1	2.24 V	89	39.6	15.5

Remarks:

1. Emission Level(dBuV/m) = Raw Value(dBuV) + Correction Factor(dB/m)
2. Correction Factor(dB/m) = Antenna Factor(dB/m) + Cable Factor(dB) – Pre-Amplifier Factor(dB)
3. Margin value = Emission Level – Limit value
4. The other emission levels were very low against the limit.
5. " * ": Fundamental frequency, the limit was restricted at the RF Output Power.
6. " # ": The radiated frequency is out of the restricted band.

RF Mode	802.11ac (VHT20)	Channel	CH 48 : 5240 MHz
Frequency Range	1 GHz ~ 40 GHz	Detector Function & Bandwidth	(PK) RB = 1 MHz, VB = 3 MHz (AV) RB = 1 MHz, VB = 10 Hz
Input Power	120 Vac, 60 Hz	Environmental Conditions	20°C, 74% RH
Tested By	Jed Wu		

Antenna Polarity & Test Distance : Horizontal at 3 m

No	Frequency (MHz)	Emission Level (dBuV/m)	Limit (dBuV/m)	Margin (dB)	Antenna Height (m)	Table Angle (Degree)	Raw Value (dBuV)	Correction Factor (dB/m)
1	*5240.00	104.4 PK			1.54 H	318	96.5	7.9
2	*5240.00	94.8 AV			1.54 H	318	86.9	7.9
3	5350.00	59.4 PK	74.0	-14.6	1.54 H	318	50.8	8.6
4	5350.00	46.5 AV	54.0	-7.5	1.54 H	318	37.9	8.6
5	#10480.00	55.4 PK	68.2	-12.8	3.24 H	266	39.5	15.9

Antenna Polarity & Test Distance : Vertical at 3 m

No	Frequency (MHz)	Emission Level (dBuV/m)	Limit (dBuV/m)	Margin (dB)	Antenna Height (m)	Table Angle (Degree)	Raw Value (dBuV)	Correction Factor (dB/m)
1	*5240.00	108.3 PK			2.03 V	22	100.4	7.9
2	*5240.00	98.0 AV			2.03 V	22	90.1	7.9
3	5350.00	59.7 PK	74.0	-14.3	2.03 V	22	51.1	8.6
4	5350.00	46.7 AV	54.0	-7.3	2.03 V	22	38.1	8.6
5	#10480.00	56.2 PK	68.2	-12.0	2.63 V	105	40.3	15.9

Remarks:

1. Emission Level(dBuV/m) = Raw Value(dBuV) + Correction Factor(dB/m)
2. Correction Factor(dB/m) = Antenna Factor(dB/m) + Cable Factor(dB) – Pre-Amplifier Factor(dB)
3. Margin value = Emission Level – Limit value
4. The other emission levels were very low against the limit.
5. " * " : Fundamental frequency, the limit was restricted at the RF Output Power.
6. " # " : The radiated frequency is out of the restricted band.



RF Mode	802.11ac (VHT20)	Channel	CH 52 : 5260 MHz
Frequency Range	1 GHz ~ 40 GHz	Detector Function & Bandwidth	(PK) RB = 1 MHz, VB = 3 MHz (AV) RB = 1 MHz, VB = 10 Hz
Input Power	120 Vac, 60 Hz	Environmental Conditions	20°C, 74% RH
Tested By	Jed Wu		

Antenna Polarity & Test Distance : Horizontal at 3 m

No	Frequency (MHz)	Emission Level (dBuV/m)	Limit (dBuV/m)	Margin (dB)	Antenna Height (m)	Table Angle (Degree)	Raw Value (dBuV)	Correction Factor (dB/m)
1	5150.00	59.4 PK	74.0	-14.6	1.55 H	309	51.9	7.5
2	5150.00	45.5 AV	54.0	-8.5	1.55 H	309	38.0	7.5
3	*5260.00	104.9 PK			1.55 H	309	96.8	8.1
4	*5260.00	94.6 AV			1.55 H	309	86.5	8.1
5	#10520.00	54.2 PK	68.2	-14.0	3.23 H	255	38.2	16.0

Antenna Polarity & Test Distance : Vertical at 3 m

No	Frequency (MHz)	Emission Level (dBuV/m)	Limit (dBuV/m)	Margin (dB)	Antenna Height (m)	Table Angle (Degree)	Raw Value (dBuV)	Correction Factor (dB/m)
1	5150.00	59.7 PK	74.0	-14.3	1.38 V	7	52.2	7.5
2	5150.00	45.7 AV	54.0	-8.3	1.38 V	7	38.2	7.5
3	*5260.00	108.7 PK			1.38 V	7	100.6	8.1
4	*5260.00	98.1 AV			1.38 V	7	90.0	8.1
5	#10520.00	55.0 PK	68.2	-13.2	1.98 V	114	39.0	16.0

Remarks:

1. Emission Level(dBuV/m) = Raw Value(dBuV) + Correction Factor(dB/m)
2. Correction Factor(dB/m) = Antenna Factor(dB/m) + Cable Factor(dB) – Pre-Amplifier Factor(dB)
3. Margin value = Emission Level – Limit value
4. The other emission levels were very low against the limit.
5. " * ": Fundamental frequency, the limit was restricted at the RF Output Power.
6. " # ": The radiated frequency is out of the restricted band.



RF Mode	802.11ac (VHT20)	Channel	CH 60 : 5300 MHz
Frequency Range	1 GHz ~ 40 GHz	Detector Function & Bandwidth	(PK) RB = 1 MHz, VB = 3 MHz (AV) RB = 1 MHz, VB = 10 Hz
Input Power	120 Vac, 60 Hz	Environmental Conditions	20°C, 74% RH
Tested By	Jed Wu		

Antenna Polarity & Test Distance : Horizontal at 3 m

No	Frequency (MHz)	Emission Level (dBuV/m)	Limit (dBuV/m)	Margin (dB)	Antenna Height (m)	Table Angle (Degree)	Raw Value (dBuV)	Correction Factor (dB/m)
1	*5300.00	106.0 PK			1.84 H	321	97.6	8.4
2	*5300.00	95.5 AV			1.84 H	321	87.1	8.4
3	10600.00	54.9 PK	74.0	-19.1	2.94 H	269	38.8	16.1
4	10600.00	42.2 AV	54.0	-11.8	2.94 H	269	26.1	16.1

Antenna Polarity & Test Distance : Vertical at 3 m

No	Frequency (MHz)	Emission Level (dBuV/m)	Limit (dBuV/m)	Margin (dB)	Antenna Height (m)	Table Angle (Degree)	Raw Value (dBuV)	Correction Factor (dB/m)
1	*5300.00	109.1 PK			1.09 V	19	100.7	8.4
2	*5300.00	98.6 AV			1.09 V	19	90.2	8.4
3	10600.00	55.7 PK	74.0	-18.3	1.69 V	108	39.6	16.1
4	10600.00	43.0 AV	54.0	-11.0	1.69 V	108	26.9	16.1

Remarks:

1. Emission Level(dBuV/m) = Raw Value(dBuV) + Correction Factor(dB/m)
2. Correction Factor(dB/m) = Antenna Factor(dB/m) + Cable Factor(dB) – Pre-Amplifier Factor(dB)
3. Margin value = Emission Level – Limit value
4. The other emission levels were very low against the limit.
5. " * " : Fundamental frequency, the limit was restricted at the RF Output Power.



RF Mode	802.11ac (VHT20)	Channel	CH 64 : 5320 MHz
Frequency Range	1 GHz ~ 40 GHz	Detector Function & Bandwidth	(PK) RB = 1 MHz, VB = 3 MHz (AV) RB = 1 MHz, VB = 10 Hz
Input Power	120 Vac, 60 Hz	Environmental Conditions	20°C, 74% RH
Tested By	Jed Wu		

Antenna Polarity & Test Distance : Horizontal at 3 m

No	Frequency (MHz)	Emission Level (dBuV/m)	Limit (dBuV/m)	Margin (dB)	Antenna Height (m)	Table Angle (Degree)	Raw Value (dBuV)	Correction Factor (dB/m)
1	*5320.00	106.5 PK			1.84 H	320	98.0	8.5
2	*5320.00	96.0 AV			1.84 H	320	87.5	8.5
3	5350.00	60.0 PK	74.0	-14.0	1.84 H	320	51.4	8.6
4	5350.00	47.1 AV	54.0	-6.9	1.84 H	320	38.5	8.6
5	10640.00	54.5 PK	74.0	-19.5	2.93 H	268	38.5	16.0
6	10640.00	41.8 AV	54.0	-12.2	2.93 H	268	25.8	16.0

Antenna Polarity & Test Distance : Vertical at 3 m

No	Frequency (MHz)	Emission Level (dBuV/m)	Limit (dBuV/m)	Margin (dB)	Antenna Height (m)	Table Angle (Degree)	Raw Value (dBuV)	Correction Factor (dB/m)
1	*5320.00	110.2 PK			1.09 V	18	101.7	8.5
2	*5320.00	99.6 AV			1.09 V	18	91.1	8.5
3	5350.00	62.5 PK	74.0	-11.5	1.09 V	18	53.9	8.6
4	5350.00	47.5 AV	54.0	-6.5	1.09 V	18	38.9	8.6
5	10640.00	55.3 PK	74.0	-18.7	1.69 V	103	39.3	16.0
6	10640.00	42.6 AV	54.0	-11.4	1.69 V	103	26.6	16.0

Remarks:

1. Emission Level(dBuV/m) = Raw Value(dBuV) + Correction Factor(dB/m)
2. Correction Factor(dB/m) = Antenna Factor(dB/m) + Cable Factor(dB) – Pre-Amplifier Factor(dB)
3. Margin value = Emission Level – Limit value
4. The other emission levels were very low against the limit.
5. " * ": Fundamental frequency, the limit was restricted at the RF Output Power.



RF Mode	802.11ac (VHT20)	Channel	CH 100 : 5500 MHz
Frequency Range	1 GHz ~ 40 GHz	Detector Function & Bandwidth	(PK) RB = 1 MHz, VB = 3 MHz (AV) RB = 1 MHz, VB = 10 Hz
Input Power	120 Vac, 60 Hz	Environmental Conditions	20°C, 74% RH
Tested By	Jed Wu		

Antenna Polarity & Test Distance : Horizontal at 3 m

No	Frequency (MHz)	Emission Level (dBuV/m)	Limit (dBuV/m)	Margin (dB)	Antenna Height (m)	Table Angle (Degree)	Raw Value (dBuV)	Correction Factor (dB/m)
1	5460.00	60.6 PK	74.0	-13.4	1.84 H	336	51.8	8.8
2	5460.00	47.1 AV	54.0	-6.9	1.84 H	336	38.3	8.8
3	#5470.00	62.0 PK	68.2	-6.2	1.84 H	336	53.2	8.8
4	*5500.00	109.1 PK			1.84 H	336	100.2	8.9
5	*5500.00	98.8 AV			1.84 H	336	89.9	8.9
6	11000.00	58.4 PK	74.0	-15.6	3.42 H	299	41.5	16.9
7	11000.00	45.7 AV	54.0	-8.3	3.42 H	299	28.8	16.9

Antenna Polarity & Test Distance : Vertical at 3 m

No	Frequency (MHz)	Emission Level (dBuV/m)	Limit (dBuV/m)	Margin (dB)	Antenna Height (m)	Table Angle (Degree)	Raw Value (dBuV)	Correction Factor (dB/m)
1	5460.00	61.0 PK	74.0	-13.0	2.09 V	35	52.2	8.8
2	5460.00	47.5 AV	54.0	-6.5	2.09 V	35	38.7	8.8
3	#5470.00	63.6 PK	68.2	-4.6	2.09 V	35	54.8	8.8
4	*5500.00	111.7 PK			2.09 V	35	102.8	8.9
5	*5500.00	101.4 AV			2.09 V	35	92.5	8.9
6	11000.00	58.8 PK	74.0	-15.2	2.69 V	123	41.9	16.9
7	11000.00	46.1 AV	54.0	-7.9	2.69 V	123	29.2	16.9

Remarks:

1. Emission Level(dBuV/m) = Raw Value(dBuV) + Correction Factor(dB/m)
2. Correction Factor(dB/m) = Antenna Factor(dB/m) + Cable Factor(dB) – Pre-Amplifier Factor(dB)
3. Margin value = Emission Level – Limit value
4. The other emission levels were very low against the limit.
5. " * " : Fundamental frequency, the limit was restricted at the RF Output Power.
6. " # " : The radiated frequency is out of the restricted band.



RF Mode	802.11ac (VHT20)	Channel	CH 116 : 5580 MHz
Frequency Range	1 GHz ~ 40 GHz	Detector Function & Bandwidth	(PK) RB = 1 MHz, VB = 3 MHz (AV) RB = 1 MHz, VB = 10 Hz
Input Power	120 Vac, 60 Hz	Environmental Conditions	20°C, 74% RH
Tested By	Jed Wu		

Antenna Polarity & Test Distance : Horizontal at 3 m

No	Frequency (MHz)	Emission Level (dBuV/m)	Limit (dBuV/m)	Margin (dB)	Antenna Height (m)	Table Angle (Degree)	Raw Value (dBuV)	Correction Factor (dB/m)
1	*5580.00	108.9 PK			2.05 H	307	100.3	8.6
2	*5580.00	98.6 AV			2.05 H	307	90.0	8.6
3	11160.00	58.2 PK	74.0	-15.8	2.37 H	270	41.2	17.0
4	11160.00	45.5 AV	54.0	-8.5	2.37 H	270	28.5	17.0

Antenna Polarity & Test Distance : Vertical at 3 m

No	Frequency (MHz)	Emission Level (dBuV/m)	Limit (dBuV/m)	Margin (dB)	Antenna Height (m)	Table Angle (Degree)	Raw Value (dBuV)	Correction Factor (dB/m)
1	*5580.00	111.7 PK			1.04 V	2	103.1	8.6
2	*5580.00	100.3 AV			1.04 V	2	91.7	8.6
3	11160.00	58.6 PK	74.0	-15.4	1.64 V	90	41.6	17.0
4	11160.00	45.9 AV	54.0	-8.1	1.64 V	90	28.9	17.0

Remarks:

1. Emission Level(dBuV/m) = Raw Value(dBuV) + Correction Factor(dB/m)
2. Correction Factor(dB/m) = Antenna Factor(dB/m) + Cable Factor(dB) – Pre-Amplifier Factor(dB)
3. Margin value = Emission Level – Limit value
4. The other emission levels were very low against the limit.
5. " * " : Fundamental frequency, the limit was restricted at the RF Output Power.



RF Mode	802.11ac (VHT20)	Channel	CH 140 : 5700 MHz
Frequency Range	1 GHz ~ 40 GHz	Detector Function & Bandwidth	(PK) RB = 1 MHz, VB = 3 MHz (AV) RB = 1 MHz, VB = 10 Hz
Input Power	120 Vac, 60 Hz	Environmental Conditions	20°C, 74% RH
Tested By	Jed Wu		

Antenna Polarity & Test Distance : Horizontal at 3 m

No	Frequency (MHz)	Emission Level (dBuV/m)	Limit (dBuV/m)	Margin (dB)	Antenna Height (m)	Table Angle (Degree)	Raw Value (dBuV)	Correction Factor (dB/m)
1	*5700.00	107.4 PK			1.22 H	274	99.3	8.1
2	*5700.00	97.1 AV			1.22 H	274	89.0	8.1
3	#5725.00	61.5 PK	68.2	-6.7	1.22 H	274	53.4	8.1
4	11400.00	57.4 PK	74.0	-16.6	3.20 H	237	39.8	17.6
5	11400.00	44.7 AV	54.0	-9.3	3.20 H	237	27.1	17.6

Antenna Polarity & Test Distance : Vertical at 3 m

No	Frequency (MHz)	Emission Level (dBuV/m)	Limit (dBuV/m)	Margin (dB)	Antenna Height (m)	Table Angle (Degree)	Raw Value (dBuV)	Correction Factor (dB/m)
1	*5700.00	109.8 PK			1.47 V	35	101.7	8.1
2	*5700.00	99.2 AV			1.47 V	35	91.1	8.1
3	#5725.00	61.8 PK	68.2	-6.4	1.47 V	35	53.7	8.1
4	11400.00	57.8 PK	74.0	-16.2	1.21 V	123	40.2	17.6
5	11400.00	45.1 AV	54.0	-8.9	1.21 V	123	27.5	17.6

Remarks:

1. Emission Level(dBuV/m) = Raw Value(dBuV) + Correction Factor(dB/m)
2. Correction Factor(dB/m) = Antenna Factor(dB/m) + Cable Factor(dB) – Pre-Amplifier Factor(dB)
3. Margin value = Emission Level – Limit value
4. The other emission levels were very low against the limit.
5. " * ": Fundamental frequency, the limit was restricted at the RF Output Power.
6. " # ": The radiated frequency is out of the restricted band.



RF Mode	802.11ac (VHT20)	Channel	CH 149 : 5745 MHz
Frequency Range	1 GHz ~ 40 GHz	Detector Function & Bandwidth	(PK) RB = 1 MHz, VB = 3 MHz (AV) RB = 1 MHz, VB = 10 Hz
Input Power	120 Vac, 60 Hz	Environmental Conditions	20°C, 74% RH
Tested By	Jed Wu		

Antenna Polarity & Test Distance : Horizontal at 3 m

No	Frequency (MHz)	Emission Level (dBuV/m)	Limit (dBuV/m)	Margin (dB)	Antenna Height (m)	Table Angle (Degree)	Raw Value (dBuV)	Correction Factor (dB/m)
1	#5627.90	59.2 PK	68.2	-9.0	2.03 H	308	50.7	8.5
2	*5745.00	108.6 PK			2.03 H	308	100.3	8.3
3	*5745.00	98.4 AV			2.03 H	308	90.1	8.3
4	#5931.43	59.5 PK	68.2	-8.7	2.03 H	308	51.0	8.5
5	11490.00	58.4 PK	74.0	-15.6	2.39 H	271	40.6	17.8
6	11490.00	45.7 AV	54.0	-8.3	2.39 H	271	27.9	17.8

Antenna Polarity & Test Distance : Vertical at 3 m

No	Frequency (MHz)	Emission Level (dBuV/m)	Limit (dBuV/m)	Margin (dB)	Antenna Height (m)	Table Angle (Degree)	Raw Value (dBuV)	Correction Factor (dB/m)
1	#5581.35	58.6 PK	68.2	-9.6	1.06 V	7	49.8	8.8
2	*5745.00	111.2 PK			1.06 V	7	102.9	8.3
3	*5745.00	100.8 AV			1.06 V	7	92.5	8.3
4	#5992.23	59.5 PK	68.2	-8.7	1.06 V	7	50.7	8.8
5	11490.00	58.8 PK	74.0	-15.2	1.66 V	95	41.0	17.8
6	11490.00	46.1 AV	54.0	-7.9	1.66 V	95	28.3	17.8

Remarks:

1. Emission Level(dBuV/m) = Raw Value(dBuV) + Correction Factor(dB/m)
2. Correction Factor(dB/m) = Antenna Factor(dB/m) + Cable Factor(dB) – Pre-Amplifier Factor(dB)
3. Margin value = Emission Level – Limit value
4. The other emission levels were very low against the limit.
5. " * ": Fundamental frequency, the limit was restricted at the RF Output Power.



RF Mode	802.11ac (VHT20)	Channel	CH 157 : 5785 MHz
Frequency Range	1 GHz ~ 40 GHz	Detector Function & Bandwidth	(PK) RB = 1 MHz, VB = 3 MHz (AV) RB = 1 MHz, VB = 10 Hz
Input Power	120 Vac, 60 Hz	Environmental Conditions	20°C, 74% RH
Tested By	Jed Wu		

Antenna Polarity & Test Distance : Horizontal at 3 m

No	Frequency (MHz)	Emission Level (dBuV/m)	Limit (dBuV/m)	Margin (dB)	Antenna Height (m)	Table Angle (Degree)	Raw Value (dBuV)	Correction Factor (dB/m)
1	#5636.45	59.2 PK	68.2	-9.0	2.14 H	272	50.8	8.4
2	*5785.00	108.0 PK			2.14 H	272	99.8	8.2
3	*5785.00	97.8 AV			2.14 H	272	89.6	8.2
4	#5974.65	60.3 PK	68.2	-7.9	2.14 H	272	51.7	8.6
5	11570.00	57.9 PK	74.0	-16.1	2.38 H	235	40.1	17.8
6	11570.00	45.2 AV	54.0	-8.8	2.38 H	235	27.4	17.8

Antenna Polarity & Test Distance : Vertical at 3 m

No	Frequency (MHz)	Emission Level (dBuV/m)	Limit (dBuV/m)	Margin (dB)	Antenna Height (m)	Table Angle (Degree)	Raw Value (dBuV)	Correction Factor (dB/m)
1	#5639.77	59.1 PK	68.2	-9.1	1.05 V	23	50.7	8.4
2	*5785.00	110.6 PK			1.05 V	23	102.4	8.2
3	*5785.00	100.2 AV			1.05 V	23	92.0	8.2
4	#6014.07	60.0 PK	68.2	-8.2	1.05 V	23	51.1	8.9
5	11570.00	58.3 PK	74.0	-15.7	1.65 V	100	40.5	17.8
6	11570.00	45.6 AV	54.0	-8.4	1.65 V	100	27.8	17.8

Remarks:

1. Emission Level(dBuV/m) = Raw Value(dBuV) + Correction Factor(dB/m)
2. Correction Factor(dB/m) = Antenna Factor(dB/m) + Cable Factor(dB) – Pre-Amplifier Factor(dB)
3. Margin value = Emission Level – Limit value
4. The other emission levels were very low against the limit.
5. " * " : Fundamental frequency, the limit was restricted at the RF Output Power.
6. " # " : The radiated frequency is out of the restricted band.



RF Mode	802.11ac (VHT20)	Channel	CH 165 : 5825 MHz
Frequency Range	1 GHz ~ 40 GHz	Detector Function & Bandwidth	(PK) RB = 1 MHz, VB = 3 MHz (AV) RB = 1 MHz, VB = 10 Hz
Input Power	120 Vac, 60 Hz	Environmental Conditions	20°C, 74% RH
Tested By	Jed Wu		

Antenna Polarity & Test Distance : Horizontal at 3 m

No	Frequency (MHz)	Emission Level (dBuV/m)	Limit (dBuV/m)	Margin (dB)	Antenna Height (m)	Table Angle (Degree)	Raw Value (dBuV)	Correction Factor (dB/m)
1	#5636.93	58.5 PK	68.2	-9.7	2.13 H	334	50.1	8.4
2	*5825.00	108.1 PK			2.13 H	334	99.9	8.2
3	*5825.00	97.5 AV			2.13 H	334	89.3	8.2
4	#6005.52	59.8 PK	68.2	-8.4	2.13 H	334	51.0	8.8
5	11650.00	57.6 PK	74.0	-16.4	2.37 H	215	39.9	17.7
6	11650.00	44.9 AV	54.0	-9.1	2.37 H	215	27.2	17.7

Antenna Polarity & Test Distance : Vertical at 3 m

No	Frequency (MHz)	Emission Level (dBuV/m)	Limit (dBuV/m)	Margin (dB)	Antenna Height (m)	Table Angle (Degree)	Raw Value (dBuV)	Correction Factor (dB/m)
1	#5573.75	59.4 PK	68.2	-8.8	1.05 V	33	50.6	8.8
2	*5825.00	110.4 PK			1.05 V	33	102.2	8.2
3	*5825.00	100.0 AV			1.05 V	33	91.8	8.2
4	#5974.18	60.4 PK	68.2	-7.8	1.05 V	33	51.8	8.6
5	11650.00	58.0 PK	74.0	-16.0	1.64 V	110	40.3	17.7
6	11650.00	45.3 AV	54.0	-8.7	1.64 V	110	27.6	17.7

Remarks:

1. Emission Level(dBuV/m) = Raw Value(dBuV) + Correction Factor(dB/m)
2. Correction Factor(dB/m) = Antenna Factor(dB/m) + Cable Factor(dB) – Pre-Amplifier Factor(dB)
3. Margin value = Emission Level – Limit value
4. The other emission levels were very low against the limit.
5. " * ": Fundamental frequency, the limit was restricted at the RF Output Power.
6. " # ": The radiated frequency is out of the restricted band.



RF Mode	802.11ac (VHT40)	Channel	CH 38 : 5190 MHz
Frequency Range	1 GHz ~ 40 GHz	Detector Function & Bandwidth	(PK) RB = 1 MHz, VB = 3 MHz (AV) RB = 1 MHz, VB = 1 kHz
Input Power	120 Vac, 60 Hz	Environmental Conditions	20°C, 74% RH
Tested By	Jed Wu		

Antenna Polarity & Test Distance : Horizontal at 3 m

No	Frequency (MHz)	Emission Level (dBuV/m)	Limit (dBuV/m)	Margin (dB)	Antenna Height (m)	Table Angle (Degree)	Raw Value (dBuV)	Correction Factor (dB/m)
1	5150.00	63.8 PK	74.0	-10.2	1.38 H	318	56.3	7.5
2	5150.00	48.8 AV	54.0	-5.2	1.38 H	318	41.3	7.5
3	*5190.00	99.9 PK			1.38 H	318	92.4	7.5
4	*5190.00	90.1 AV			1.38 H	318	82.6	7.5
5	#10380.00	54.3 PK	68.2	-13.9	3.40 H	260	38.7	15.6

Antenna Polarity & Test Distance : Vertical at 3 m

No	Frequency (MHz)	Emission Level (dBuV/m)	Limit (dBuV/m)	Margin (dB)	Antenna Height (m)	Table Angle (Degree)	Raw Value (dBuV)	Correction Factor (dB/m)
1	5150.00	65.1 PK	74.0	-8.9	1.87 V	21	57.6	7.5
2	5150.00	50.8 AV	54.0	-3.2	1.87 V	21	43.3	7.5
3	*5190.00	103.7 PK			1.87 V	21	96.2	7.5
4	*5190.00	93.1 AV			1.87 V	21	85.6	7.5
5	#10380.00	55.1 PK	68.2	-13.1	2.15 V	100	39.5	15.6

Remarks:

1. Emission Level(dBuV/m) = Raw Value(dBuV) + Correction Factor(dB/m)
2. Correction Factor(dB/m) = Antenna Factor(dB/m) + Cable Factor(dB) – Pre-Amplifier Factor(dB)
3. Margin value = Emission Level – Limit value
4. The other emission levels were very low against the limit.
5. " * ": Fundamental frequency, the limit was restricted at the RF Output Power.
6. " # ": The radiated frequency is out of the restricted band.



RF Mode	802.11ac (VHT40)	Channel	CH 46 : 5230 MHz
Frequency Range	1 GHz ~ 40 GHz	Detector Function & Bandwidth	(PK) RB = 1 MHz, VB = 3 MHz (AV) RB = 1 MHz, VB = 1 kHz
Input Power	120 Vac, 60 Hz	Environmental Conditions	20°C, 74% RH
Tested By	Jed Wu		

Antenna Polarity & Test Distance : Horizontal at 3 m

No	Frequency (MHz)	Emission Level (dBuV/m)	Limit (dBuV/m)	Margin (dB)	Antenna Height (m)	Table Angle (Degree)	Raw Value (dBuV)	Correction Factor (dB/m)
1	*5230.00	101.4 PK			1.37 H	312	93.6	7.8
2	*5230.00	91.3 AV			1.37 H	312	83.5	7.8
3	5350.00	59.0 PK	74.0	-15.0	1.37 H	312	50.4	8.6
4	5350.00	46.5 AV	54.0	-7.5	1.37 H	312	37.9	8.6
5	#10460.00	55.8 PK	68.2	-12.4	3.41 H	266	39.9	15.9

Antenna Polarity & Test Distance : Vertical at 3 m

No	Frequency (MHz)	Emission Level (dBuV/m)	Limit (dBuV/m)	Margin (dB)	Antenna Height (m)	Table Angle (Degree)	Raw Value (dBuV)	Correction Factor (dB/m)
1	*5230.00	105.2 PK			1.86 V	22	97.4	7.8
2	*5230.00	94.8 AV			1.86 V	22	87.0	7.8
3	5350.00	59.4 PK	74.0	-14.6	1.86 V	22	50.8	8.6
4	5350.00	46.7 AV	54.0	-7.3	1.86 V	22	38.1	8.6
5	#10460.00	56.6 PK	68.2	-11.6	2.14 V	101	40.7	15.9

Remarks:

1. Emission Level(dBuV/m) = Raw Value(dBuV) + Correction Factor(dB/m)
2. Correction Factor(dB/m) = Antenna Factor(dB/m) + Cable Factor(dB) – Pre-Amplifier Factor(dB)
3. Margin value = Emission Level – Limit value
4. The other emission levels were very low against the limit.
5. " * ": Fundamental frequency, the limit was restricted at the RF Output Power.
6. " # ": The radiated frequency is out of the restricted band.



RF Mode	802.11ac (VHT40)	Channel	CH 54 : 5270 MHz
Frequency Range	1 GHz ~ 40 GHz	Detector Function & Bandwidth	(PK) RB = 1 MHz, VB = 3 MHz (AV) RB = 1 MHz, VB = 1 kHz
Input Power	120 Vac, 60 Hz	Environmental Conditions	20°C, 74% RH
Tested By	Jed Wu		

Antenna Polarity & Test Distance : Horizontal at 3 m

No	Frequency (MHz)	Emission Level (dBuV/m)	Limit (dBuV/m)	Margin (dB)	Antenna Height (m)	Table Angle (Degree)	Raw Value (dBuV)	Correction Factor (dB/m)
1	5150.00	58.9 PK	74.0	-15.1	1.14 H	297	51.4	7.5
2	5150.00	45.5 AV	54.0	-8.5	1.14 H	297	38.0	7.5
3	*5270.00	100.5 PK			1.14 H	297	92.4	8.1
4	*5270.00	90.2 AV			1.14 H	297	82.1	8.1
5	#10540.00	54.6 PK	68.2	-13.6	2.94 H	245	38.7	15.9

Antenna Polarity & Test Distance : Vertical at 3 m

No	Frequency (MHz)	Emission Level (dBuV/m)	Limit (dBuV/m)	Margin (dB)	Antenna Height (m)	Table Angle (Degree)	Raw Value (dBuV)	Correction Factor (dB/m)
1	5150.00	59.2 PK	74.0	-14.8	1.09 V	355	51.7	7.5
2	5150.00	45.8 AV	54.0	-8.2	1.09 V	355	38.3	7.5
3	*5270.00	104.8 PK			1.09 V	355	96.7	8.1
4	*5270.00	94.3 AV			1.09 V	355	86.2	8.1
5	#10540.00	55.4 PK	68.2	-12.8	2.39 V	126	39.5	15.9

Remarks:

1. Emission Level(dBuV/m) = Raw Value(dBuV) + Correction Factor(dB/m)
2. Correction Factor(dB/m) = Antenna Factor(dB/m) + Cable Factor(dB) – Pre-Amplifier Factor(dB)
3. Margin value = Emission Level – Limit value
4. The other emission levels were very low against the limit.
5. " * ": Fundamental frequency, the limit was restricted at the RF Output Power.
6. " # ": The radiated frequency is out of the restricted band.



RF Mode	802.11ac (VHT40)	Channel	CH 62 : 5310 MHz
Frequency Range	1 GHz ~ 40 GHz	Detector Function & Bandwidth	(PK) RB = 1 MHz, VB = 3 MHz (AV) RB = 1 MHz, VB = 1 kHz
Input Power	120 Vac, 60 Hz	Environmental Conditions	20°C, 74% RH
Tested By	Jed Wu		

Antenna Polarity & Test Distance : Horizontal at 3 m

No	Frequency (MHz)	Emission Level (dBuV/m)	Limit (dBuV/m)	Margin (dB)	Antenna Height (m)	Table Angle (Degree)	Raw Value (dBuV)	Correction Factor (dB/m)
1	*5310.00	102.5 PK			1.64 H	316	94.1	8.4
2	*5310.00	92.2 AV			1.64 H	316	83.8	8.4
3	5350.00	60.7 PK	74.0	-13.3	1.64 H	316	52.1	8.6
4	5350.00	48.1 AV	54.0	-5.9	1.64 H	316	39.5	8.6
5	10620.00	55.0 PK	74.0	-19.0	3.15 H	264	39.0	16.0
6	10620.00	42.3 AV	54.0	-11.7	3.15 H	264	26.3	16.0

Antenna Polarity & Test Distance : Vertical at 3 m

No	Frequency (MHz)	Emission Level (dBuV/m)	Limit (dBuV/m)	Margin (dB)	Antenna Height (m)	Table Angle (Degree)	Raw Value (dBuV)	Correction Factor (dB/m)
1	*5310.00	106.0 PK			1.59 V	18	97.6	8.4
2	*5310.00	95.5 AV			1.59 V	18	87.1	8.4
3	5350.00	62.2 PK	74.0	-11.8	1.59 V	18	53.6	8.6
4	5350.00	49.5 AV	54.0	-4.5	1.59 V	18	40.9	8.6
5	10620.00	55.8 PK	74.0	-18.2	1.89 V	107	39.8	16.0
6	10620.00	43.1 AV	54.0	-10.9	1.89 V	107	27.1	16.0

Remarks:

1. Emission Level(dBuV/m) = Raw Value(dBuV) + Correction Factor(dB/m)
2. Correction Factor(dB/m) = Antenna Factor(dB/m) + Cable Factor(dB) – Pre-Amplifier Factor(dB)
3. Margin value = Emission Level – Limit value
4. The other emission levels were very low against the limit.
5. " * ": Fundamental frequency, the limit was restricted at the RF Output Power.



RF Mode	802.11ac (VHT40)	Channel	CH 102 : 5510 MHz
Frequency Range	1 GHz ~ 40 GHz	Detector Function & Bandwidth	(PK) RB = 1 MHz, VB = 3 MHz (AV) RB = 1 MHz, VB = 1 kHz
Input Power	120 Vac, 60 Hz	Environmental Conditions	20°C, 74% RH
Tested By	Jed Wu		

Antenna Polarity & Test Distance : Horizontal at 3 m

No	Frequency (MHz)	Emission Level (dBuV/m)	Limit (dBuV/m)	Margin (dB)	Antenna Height (m)	Table Angle (Degree)	Raw Value (dBuV)	Correction Factor (dB/m)
1	5460.00	60.2 PK	74.0	-13.8	1.43 H	276	51.4	8.8
2	5460.00	47.1 AV	54.0	-6.9	1.43 H	276	38.3	8.8
3	#5470.00	62.8 PK	68.2	-5.4	1.43 H	276	54.0	8.8
4	*5510.00	102.6 PK			1.43 H	276	93.8	8.8
5	*5510.00	91.7 AV			1.43 H	276	82.9	8.8
6	11020.00	56.4 PK	74.0	-17.6	3.01 H	239	39.6	16.8
7	11020.00	43.8 AV	54.0	-10.2	3.01 H	239	27.0	16.8

Antenna Polarity & Test Distance : Vertical at 3 m

No	Frequency (MHz)	Emission Level (dBuV/m)	Limit (dBuV/m)	Margin (dB)	Antenna Height (m)	Table Angle (Degree)	Raw Value (dBuV)	Correction Factor (dB/m)
1	5460.00	63.2 PK	74.0	-10.8	1.68 V	33	54.4	8.8
2	5460.00	48.1 AV	54.0	-5.9	1.68 V	33	39.3	8.8
3	#5470.00	65.0 PK	68.2	-3.2	1.68 V	33	56.2	8.8
4	*5510.00	105.3 PK			1.68 V	33	96.5	8.8
5	*5510.00	95.0 AV			1.68 V	33	86.2	8.8
6	11020.00	56.8 PK	74.0	-17.2	1.42 V	121	40.0	16.8
7	11020.00	44.1 AV	54.0	-9.9	1.42 V	121	27.3	16.8

Remarks:

1. Emission Level(dBuV/m) = Raw Value(dBuV) + Correction Factor(dB/m)
2. Correction Factor(dB/m) = Antenna Factor(dB/m) + Cable Factor(dB) – Pre-Amplifier Factor(dB)
3. Margin value = Emission Level – Limit value
4. The other emission levels were very low against the limit.
5. " * " : Fundamental frequency, the limit was restricted at the RF Output Power.
6. " # " : The radiated frequency is out of the restricted band.



RF Mode	802.11ac (VHT40)	Channel	CH 110 : 5550 MHz
Frequency Range	1 GHz ~ 40 GHz	Detector Function & Bandwidth	(PK) RB = 1 MHz, VB = 3 MHz (AV) RB = 1 MHz, VB = 1 kHz
Input Power	120 Vac, 60 Hz	Environmental Conditions	20°C, 74% RH
Tested By	Jed Wu		

Antenna Polarity & Test Distance : Horizontal at 3 m

No	Frequency (MHz)	Emission Level (dBuV/m)	Limit (dBuV/m)	Margin (dB)	Antenna Height (m)	Table Angle (Degree)	Raw Value (dBuV)	Correction Factor (dB/m)
1	*5550.00	105.1 PK			1.56 H	332	96.3	8.8
2	*5550.00	94.7 AV			1.56 H	332	85.9	8.8
3	11100.00	56.7 PK	74.0	-17.3	3.14 H	295	40.2	16.5
4	11100.00	44.0 AV	54.0	-10.0	3.14 H	295	27.5	16.5

Antenna Polarity & Test Distance : Vertical at 3 m

No	Frequency (MHz)	Emission Level (dBuV/m)	Limit (dBuV/m)	Margin (dB)	Antenna Height (m)	Table Angle (Degree)	Raw Value (dBuV)	Correction Factor (dB/m)
1	*5550.00	107.9 PK			1.81 V	31	99.1	8.8
2	*5550.00	97.4 AV			1.81 V	31	88.6	8.8
3	11100.00	57.1 PK	74.0	-16.9	1.55 V	123	40.6	16.5
4	11100.00	44.4 AV	54.0	-9.6	1.55 V	123	27.9	16.5

Remarks:

1. Emission Level(dBuV/m) = Raw Value(dBuV) + Correction Factor(dB/m)
2. Correction Factor(dB/m) = Antenna Factor(dB/m) + Cable Factor(dB) – Pre-Amplifier Factor(dB)
3. Margin value = Emission Level – Limit value
4. The other emission levels were very low against the limit.
5. " * ": Fundamental frequency, the limit was restricted at the RF Output Power.



RF Mode	802.11ac (VHT40)	Channel	CH 134 : 5670 MHz
Frequency Range	1 GHz ~ 40 GHz	Detector Function & Bandwidth	(PK) RB = 1 MHz, VB = 3 MHz (AV) RB = 1 MHz, VB = 1 kHz
Input Power	120 Vac, 60 Hz	Environmental Conditions	20°C, 74% RH
Tested By	Jed Wu		

Antenna Polarity & Test Distance : Horizontal at 3 m

No	Frequency (MHz)	Emission Level (dBuV/m)	Limit (dBuV/m)	Margin (dB)	Antenna Height (m)	Table Angle (Degree)	Raw Value (dBuV)	Correction Factor (dB/m)
1	*5670.00	103.6 PK			1.50 H	326	95.5	8.1
2	*5670.00	93.2 AV			1.50 H	326	85.1	8.1
3	#5725.00	59.7 PK	68.2	-8.5	1.50 H	326	51.6	8.1
4	11340.00	58.2 PK	74.0	-15.8	3.08 H	289	40.8	17.4
5	11340.00	45.5 AV	54.0	-8.5	3.08 H	289	28.1	17.4

Antenna Polarity & Test Distance : Vertical at 3 m

No	Frequency (MHz)	Emission Level (dBuV/m)	Limit (dBuV/m)	Margin (dB)	Antenna Height (m)	Table Angle (Degree)	Raw Value (dBuV)	Correction Factor (dB/m)
1	*5670.00	106.6 PK			1.75 V	25	98.5	8.1
2	*5670.00	96.0 AV			1.75 V	25	87.9	8.1
3	#5725.00	60.0 PK	68.2	-8.2	1.75 V	25	51.9	8.1
4	11340.00	58.6 PK	74.0	-15.4	1.61 V	129	41.2	17.4
5	11340.00	45.9 AV	54.0	-8.1	1.61 V	129	28.5	17.4

Remarks:

1. Emission Level(dBuV/m) = Raw Value(dBuV) + Correction Factor(dB/m)
2. Correction Factor(dB/m) = Antenna Factor(dB/m) + Cable Factor(dB) – Pre-Amplifier Factor(dB)
3. Margin value = Emission Level – Limit value
4. The other emission levels were very low against the limit.
5. " * ": Fundamental frequency, the limit was restricted at the RF Output Power.
6. " # ": The radiated frequency is out of the restricted band.



RF Mode	802.11ac (VHT40)	Channel	CH 151 : 5755 MHz
Frequency Range	1 GHz ~ 40 GHz	Detector Function & Bandwidth	(PK) RB = 1 MHz, VB = 3 MHz (AV) RB = 1 MHz, VB = 1 kHz
Input Power	120 Vac, 60 Hz	Environmental Conditions	20°C, 74% RH
Tested By	Jed Wu		

Antenna Polarity & Test Distance : Horizontal at 3 m

No	Frequency (MHz)	Emission Level (dBuV/m)	Limit (dBuV/m)	Margin (dB)	Antenna Height (m)	Table Angle (Degree)	Raw Value (dBuV)	Correction Factor (dB/m)
1	#5626.48	59.1 PK	68.2	-9.1	2.46 H	310	50.6	8.5
2	*5755.00	105.2 PK			2.46 H	310	96.8	8.4
3	*5755.00	94.4 AV			2.46 H	310	86.0	8.4
4	#5997.45	60.6 PK	68.2	-7.6	2.46 H	310	51.8	8.8
5	11510.00	58.6 PK	74.0	-15.4	2.70 H	239	40.8	17.8
6	11510.00	45.9 AV	54.0	-8.1	2.70 H	239	28.1	17.8

Antenna Polarity & Test Distance : Vertical at 3 m

No	Frequency (MHz)	Emission Level (dBuV/m)	Limit (dBuV/m)	Margin (dB)	Antenna Height (m)	Table Angle (Degree)	Raw Value (dBuV)	Correction Factor (dB/m)
1	#5650.70	60.1 PK	68.7	-8.6	1.37 V	9	51.7	8.4
2	*5755.00	107.5 PK			1.37 V	9	99.1	8.4
3	*5755.00	96.8 AV			1.37 V	9	88.4	8.4
4	#6021.20	59.6 PK	68.2	-8.6	1.37 V	9	50.7	8.9
5	11510.00	59.0 PK	74.0	-15.0	1.97 V	97	41.2	17.8
6	11510.00	46.3 AV	54.0	-7.7	1.97 V	97	28.5	17.8

Remarks:

1. Emission Level(dBuV/m) = Raw Value(dBuV) + Correction Factor(dB/m)
2. Correction Factor(dB/m) = Antenna Factor(dB/m) + Cable Factor(dB) – Pre-Amplifier Factor(dB)
3. Margin value = Emission Level – Limit value
4. The other emission levels were very low against the limit.
5. " * ": Fundamental frequency, the limit was restricted at the RF Output Power.



RF Mode	802.11ac (VHT40)	Channel	CH 159 : 5795 MHz
Frequency Range	1 GHz ~ 40 GHz	Detector Function & Bandwidth	(PK) RB = 1 MHz, VB = 3 MHz (AV) RB = 1 MHz, VB = 1 kHz
Input Power	120 Vac, 60 Hz	Environmental Conditions	20°C, 74% RH
Tested By	Jed Wu		

Antenna Polarity & Test Distance : Horizontal at 3 m

No	Frequency (MHz)	Emission Level (dBuV/m)	Limit (dBuV/m)	Margin (dB)	Antenna Height (m)	Table Angle (Degree)	Raw Value (dBuV)	Correction Factor (dB/m)
1	#5627.90	59.5 PK	68.2	-8.7	2.80 H	332	51.0	8.5
2	*5795.00	104.3 PK			2.80 H	332	96.1	8.2
3	*5795.00	94.6 AV			2.80 H	332	86.4	8.2
4	#6013.60	60.4 PK	68.2	-7.8	2.80 H	332	51.6	8.8
5	11590.00	58.9 PK	74.0	-15.1	3.04 H	297	41.1	17.8
6	11590.00	46.2 AV	54.0	-7.8	3.04 H	297	28.4	17.8

Antenna Polarity & Test Distance : Vertical at 3 m

No	Frequency (MHz)	Emission Level (dBuV/m)	Limit (dBuV/m)	Margin (dB)	Antenna Height (m)	Table Angle (Degree)	Raw Value (dBuV)	Correction Factor (dB/m)
1	#5608.90	59.0 PK	68.2	-9.2	1.71 V	32	50.4	8.6
2	*5795.00	107.6 PK			1.71 V	32	99.4	8.2
3	*5795.00	96.9 AV			1.71 V	32	88.7	8.2
4	#6013.12	59.7 PK	68.2	-8.5	1.71 V	32	50.9	8.8
5	11590.00	59.3 PK	74.0	-14.7	2.31 V	120	41.5	17.8
6	11590.00	46.6 AV	54.0	-7.4	2.31 V	120	28.8	17.8

Remarks:

1. Emission Level(dBuV/m) = Raw Value(dBuV) + Correction Factor(dB/m)
2. Correction Factor(dB/m) = Antenna Factor(dB/m) + Cable Factor(dB) – Pre-Amplifier Factor(dB)
3. Margin value = Emission Level – Limit value
4. The other emission levels were very low against the limit.
5. " * ": Fundamental frequency, the limit was restricted at the RF Output Power.
6. " # ": The radiated frequency is out of the restricted band.

RF Mode	802.11ac (VHT80)	Channel	CH 42 : 5210 MHz
Frequency Range	1 GHz ~ 40 GHz	Detector Function & Bandwidth	(PK) RB = 1 MHz, VB = 3 MHz (AV) RB = 1 MHz, VB = 1 kHz
Input Power	120 Vac, 60 Hz	Environmental Conditions	20°C, 74% RH
Tested By	Jed Wu		

Antenna Polarity & Test Distance : Horizontal at 3 m

No	Frequency (MHz)	Emission Level (dBuV/m)	Limit (dBuV/m)	Margin (dB)	Antenna Height (m)	Table Angle (Degree)	Raw Value (dBuV)	Correction Factor (dB/m)
1	5150.00	62.9 PK	74.0	-11.1	1.37 H	317	55.4	7.5
2	5150.00	49.0 AV	54.0	-5.0	1.37 H	317	41.5	7.5
3	*5210.00	95.8 PK			1.37 H	317	88.1	7.7
4	*5210.00	85.9 AV			1.37 H	317	78.2	7.7
5	5350.00	59.6 PK	74.0	-14.4	1.37 H	317	51.0	8.6
6	5350.00	46.4 AV	54.0	-7.6	1.37 H	317	37.8	8.6
7	#10420.00	54.3 PK	68.2	-13.9	3.40 H	265	38.6	15.7

Antenna Polarity & Test Distance : Vertical at 3 m

No	Frequency (MHz)	Emission Level (dBuV/m)	Limit (dBuV/m)	Margin (dB)	Antenna Height (m)	Table Angle (Degree)	Raw Value (dBuV)	Correction Factor (dB/m)
1	5150.00	64.8 PK	74.0	-9.2	1.86 V	21	57.3	7.5
2	5150.00	50.6 AV	54.0	-3.4	1.86 V	21	43.1	7.5
3	*5210.00	100.0 PK			1.86 V	21	92.3	7.7
4	*5210.00	89.8 AV			1.86 V	21	82.1	7.7
5	5350.00	59.9 PK	74.0	-14.1	1.86 V	21	51.3	8.6
6	5350.00	46.7 AV	54.0	-7.3	1.86 V	21	38.1	8.6
7	#10420.00	55.0 PK	68.2	-13.2	2.16 V	105	39.3	15.7

Remarks:

1. Emission Level(dBuV/m) = Raw Value(dBuV) + Correction Factor(dB/m)
2. Correction Factor(dB/m) = Antenna Factor(dB/m) + Cable Factor(dB) – Pre-Amplifier Factor(dB)
3. Margin value = Emission Level – Limit value
4. The other emission levels were very low against the limit.
5. " * " : Fundamental frequency, the limit was restricted at the RF Output Power.
6. " # " : The radiated frequency is out of the restricted band.



RF Mode	802.11ac (VHT80)	Channel	CH 58 : 5290 MHz
Frequency Range	1 GHz ~ 40 GHz	Detector Function & Bandwidth	(PK) RB = 1 MHz, VB = 3 MHz (AV) RB = 1 MHz, VB = 1 kHz
Input Power	120 Vac, 60 Hz	Environmental Conditions	20°C, 74% RH
Tested By	Jed Wu		

Antenna Polarity & Test Distance : Horizontal at 3 m

No	Frequency (MHz)	Emission Level (dBuV/m)	Limit (dBuV/m)	Margin (dB)	Antenna Height (m)	Table Angle (Degree)	Raw Value (dBuV)	Correction Factor (dB/m)
1	5150.00	58.4 PK	74.0	-15.6	1.57 H	317	50.9	7.5
2	5150.00	45.6 AV	54.0	-8.4	1.57 H	317	38.1	7.5
3	*5290.00	97.0 PK			1.57 H	317	88.6	8.4
4	*5290.00	86.9 AV			1.57 H	317	78.5	8.4
5	5350.00	62.1 PK	74.0	-11.9	1.57 H	317	53.5	8.6
6	5350.00	48.0 AV	54.0	-6.0	1.57 H	317	39.4	8.6
7	#10580.00	54.7 PK	68.2	-13.5	3.21 H	265	38.6	16.1

Antenna Polarity & Test Distance : Vertical at 3 m

No	Frequency (MHz)	Emission Level (dBuV/m)	Limit (dBuV/m)	Margin (dB)	Antenna Height (m)	Table Angle (Degree)	Raw Value (dBuV)	Correction Factor (dB/m)
1	5150.00	58.6 PK	74.0	-15.4	1.52 V	16	51.1	7.5
2	5150.00	45.8 AV	54.0	-8.2	1.52 V	16	38.3	7.5
3	*5290.00	101.2 PK			1.52 V	16	92.8	8.4
4	*5290.00	90.8 AV			1.52 V	16	82.4	8.4
5	5350.00	63.1 PK	74.0	-10.9	1.52 V	16	54.5	8.6
6	5350.00	48.8 AV	54.0	-5.2	1.52 V	16	40.2	8.6
7	#10580.00	55.5 PK	68.2	-12.7	2.12 V	104	39.4	16.1

Remarks:

1. Emission Level(dBuV/m) = Raw Value(dBuV) + Correction Factor(dB/m)
2. Correction Factor(dB/m) = Antenna Factor(dB/m) + Cable Factor(dB) – Pre-Amplifier Factor(dB)
3. Margin value = Emission Level – Limit value
4. The other emission levels were very low against the limit.
5. " * " : Fundamental frequency, the limit was restricted at the RF Output Power.
6. " # " : The radiated frequency is out of the restricted band.



RF Mode	802.11ac (VHT80)	Channel	CH 106 : 5530 MHz
Frequency Range	1 GHz ~ 40 GHz	Detector Function & Bandwidth	(PK) RB = 1 MHz, VB = 3 MHz (AV) RB = 1 MHz, VB = 1 kHz
Input Power	120 Vac, 60 Hz	Environmental Conditions	20°C, 74% RH
Tested By	Jed Wu		

Antenna Polarity & Test Distance : Horizontal at 3 m

No	Frequency (MHz)	Emission Level (dBuV/m)	Limit (dBuV/m)	Margin (dB)	Antenna Height (m)	Table Angle (Degree)	Raw Value (dBuV)	Correction Factor (dB/m)
1	5460.00	61.1 PK	74.0	-12.9	1.64 H	304	52.3	8.8
2	5460.00	48.5 AV	54.0	-5.5	1.64 H	304	39.7	8.8
3	#5470.00	62.5 PK	68.2	-5.7	1.64 H	304	53.7	8.8
4	*5530.00	100.5 PK			1.64 H	304	91.7	8.8
5	*5530.00	90.2 AV			1.64 H	304	81.4	8.8
6	11060.00	57.1 PK	74.0	-16.9	3.22 H	267	40.5	16.6
7	11060.00	44.4 AV	54.0	-9.6	3.22 H	267	27.8	16.6

Antenna Polarity & Test Distance : Vertical at 3 m

No	Frequency (MHz)	Emission Level (dBuV/m)	Limit (dBuV/m)	Margin (dB)	Antenna Height (m)	Table Angle (Degree)	Raw Value (dBuV)	Correction Factor (dB/m)
1	5460.00	62.7 PK	74.0	-11.3	1.89 V	4	53.9	8.8
2	5460.00	50.0 AV	54.0	-4.0	1.89 V	4	41.2	8.8
3	#5470.00	64.9 PK	68.2	-3.3	1.89 V	4	56.1	8.8
4	*5530.00	103.4 PK			1.89 V	4	94.6	8.8
5	*5530.00	92.9 AV			1.89 V	4	84.1	8.8
6	11060.00	57.5 PK	74.0	-16.5	1.75 V	108	40.9	16.6
7	11060.00	44.8 AV	54.0	-9.2	1.75 V	108	28.2	16.6

Remarks:

1. Emission Level(dBuV/m) = Raw Value(dBuV) + Correction Factor(dB/m)
2. Correction Factor(dB/m) = Antenna Factor(dB/m) + Cable Factor(dB) – Pre-Amplifier Factor(dB)
3. Margin value = Emission Level – Limit value
4. The other emission levels were very low against the limit.
5. " * " : Fundamental frequency, the limit was restricted at the RF Output Power.
6. " # " : The radiated frequency is out of the restricted band.



RF Mode	802.11ac (VHT80)	Channel	CH 122 : 5610 MHz
Frequency Range	1 GHz ~ 40 GHz	Detector Function & Bandwidth	(PK) RB = 1 MHz, VB = 3 MHz (AV) RB = 1 MHz, VB = 1 kHz
Input Power	120 Vac, 60 Hz	Environmental Conditions	20°C, 74% RH
Tested By	Jed Wu		

Antenna Polarity & Test Distance : Horizontal at 3 m

No	Frequency (MHz)	Emission Level (dBuV/m)	Limit (dBuV/m)	Margin (dB)	Antenna Height (m)	Table Angle (Degree)	Raw Value (dBuV)	Correction Factor (dB/m)
1	*5610.00	100.9 PK			1.33 H	276	92.5	8.4
2	*5610.00	90.7 AV			1.33 H	276	82.3	8.4
3	#5725.00	59.1 PK	68.2	-9.1	1.33 H	276	51.0	8.1
4	11220.00	58.6 PK	74.0	-15.4	2.75 H	239	41.2	17.4
5	11220.00	46.0 AV	54.0	-8.0	2.75 H	239	28.6	17.4

Antenna Polarity & Test Distance : Vertical at 3 m

No	Frequency (MHz)	Emission Level (dBuV/m)	Limit (dBuV/m)	Margin (dB)	Antenna Height (m)	Table Angle (Degree)	Raw Value (dBuV)	Correction Factor (dB/m)
1	*5610.00	103.8 PK			1.58 V	33	95.4	8.4
2	*5610.00	93.0 AV			1.58 V	33	84.6	8.4
3	#5725.00	59.4 PK	68.2	-8.8	1.58 V	33	51.3	8.1
4	11220.00	59.0 PK	74.0	-15.0	1.44 V	137	41.6	17.4
5	11220.00	46.4 AV	54.0	-7.6	1.44 V	137	29.0	17.4

Remarks:

1. Emission Level(dBuV/m) = Raw Value(dBuV) + Correction Factor(dB/m)
2. Correction Factor(dB/m) = Antenna Factor(dB/m) + Cable Factor(dB) – Pre-Amplifier Factor(dB)
3. Margin value = Emission Level – Limit value
4. The other emission levels were very low against the limit.
5. " * ": Fundamental frequency, the limit was restricted at the RF Output Power.
6. " # ": The radiated frequency is out of the restricted band.



RF Mode	802.11ac (VHT80)	Channel	CH 155 : 5775 MHz
Frequency Range	1 GHz ~ 40 GHz	Detector Function & Bandwidth	(PK) RB = 1 MHz, VB = 3 MHz (AV) RB = 1 MHz, VB = 1 kHz
Input Power	120 Vac, 60 Hz	Environmental Conditions	20°C, 74% RH
Tested By	Jed Wu		

Antenna Polarity & Test Distance : Horizontal at 3 m

No	Frequency (MHz)	Emission Level (dBuV/m)	Limit (dBuV/m)	Margin (dB)	Antenna Height (m)	Table Angle (Degree)	Raw Value (dBuV)	Correction Factor (dB/m)
1	#5647.85	59.0 PK	68.2	-9.2	2.66 H	330	50.6	8.4
2	*5775.00	101.1 PK			2.66 H	330	92.9	8.2
3	*5775.00	90.6 AV			2.66 H	330	82.4	8.2
4	#5985.57	60.0 PK	68.2	-8.2	2.66 H	330	51.2	8.8
5	11550.00	58.4 PK	74.0	-15.6	2.90 H	299	40.6	17.8
6	11550.00	45.7 AV	54.0	-8.3	2.90 H	299	27.9	17.8

Antenna Polarity & Test Distance : Vertical at 3 m

No	Frequency (MHz)	Emission Level (dBuV/m)	Limit (dBuV/m)	Margin (dB)	Antenna Height (m)	Table Angle (Degree)	Raw Value (dBuV)	Correction Factor (dB/m)
1	#5582.77	58.9 PK	68.2	-9.3	1.57 V	32	50.2	8.7
2	*5775.00	103.3 PK			1.57 V	32	95.1	8.2
3	*5775.00	92.7 AV			1.57 V	32	84.5	8.2
4	#5980.35	59.9 PK	68.2	-8.3	1.57 V	32	51.2	8.7
5	11550.00	58.8 PK	74.0	-15.2	2.17 V	40	41.0	17.8
6	11550.00	46.1 AV	54.0	-7.9	2.17 V	40	28.3	17.8

Remarks:

1. Emission Level(dBuV/m) = Raw Value(dBuV) + Correction Factor(dB/m)
2. Correction Factor(dB/m) = Antenna Factor(dB/m) + Cable Factor(dB) – Pre-Amplifier Factor(dB)
3. Margin value = Emission Level – Limit value
4. The other emission levels were very low against the limit.
5. " * ": Fundamental frequency, the limit was restricted at the RF Output Power.

Plot of Band Edge

802.11a Channel 36

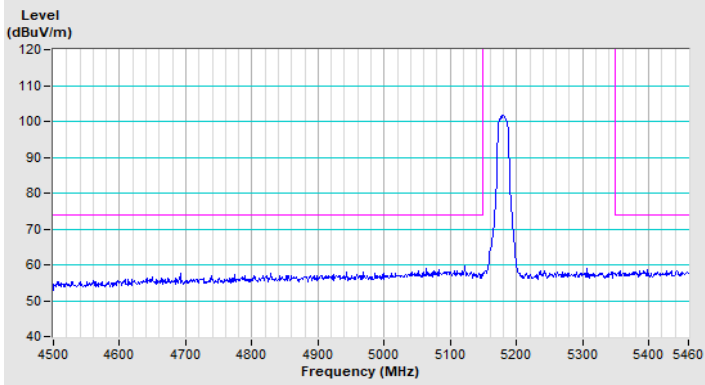

Horizontal (Peak)

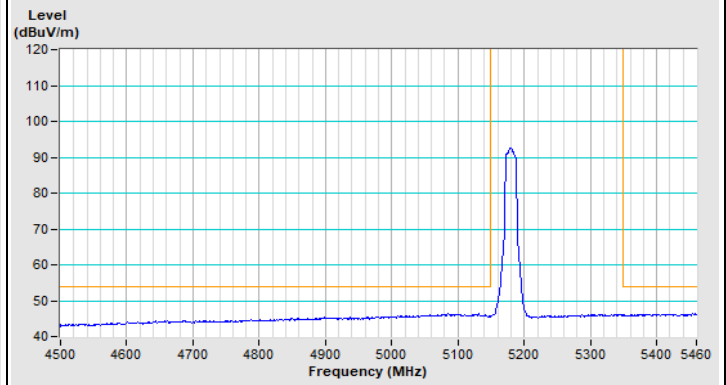

Horizontal (Average)

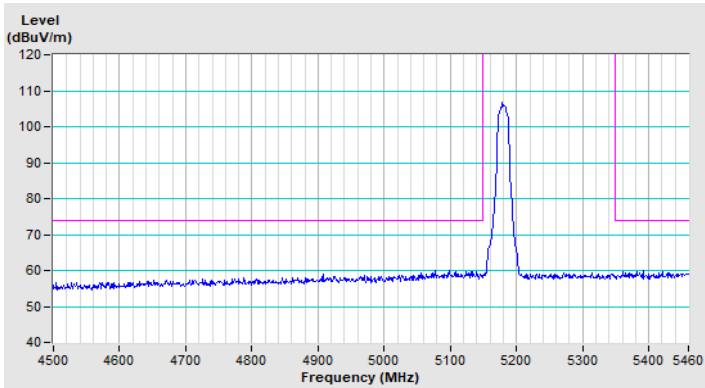

Vertical (Peak)

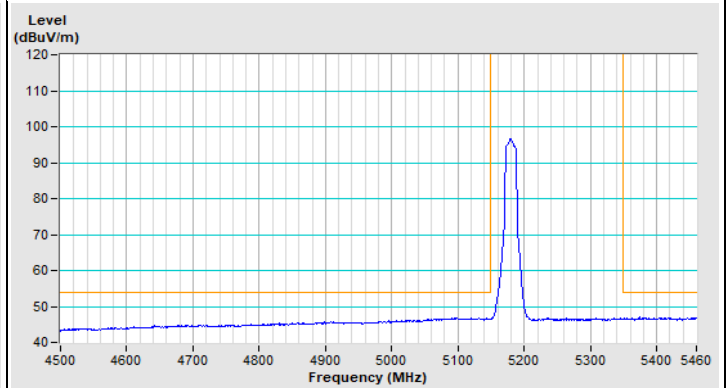

Vertical (Average)

802.11a Channel 48

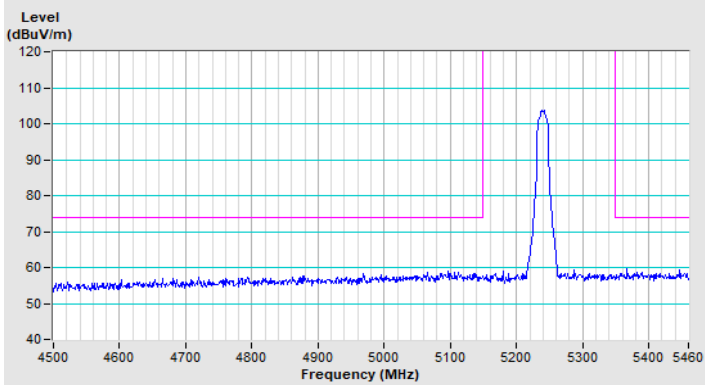

Horizontal (Peak)

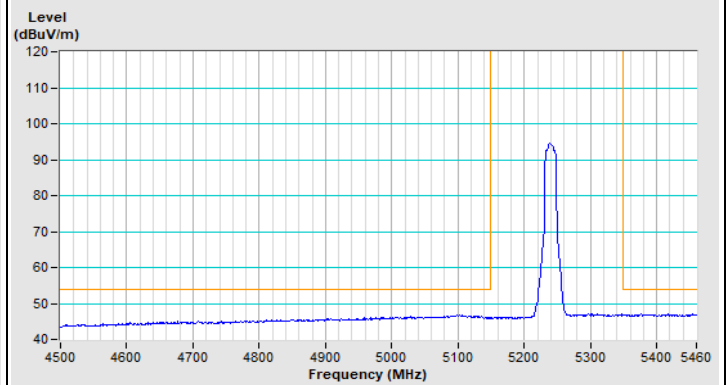

Horizontal (Average)

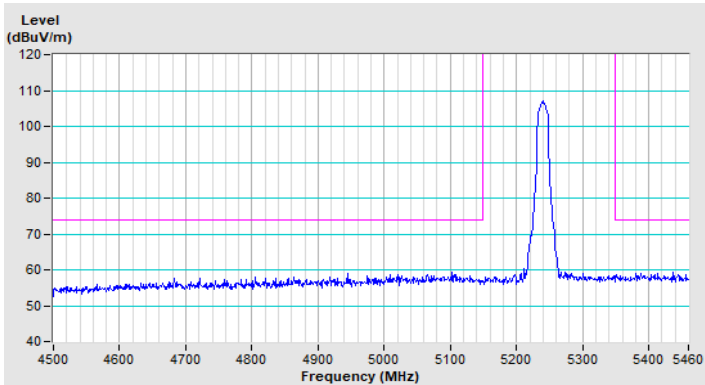

Vertical (Peak)

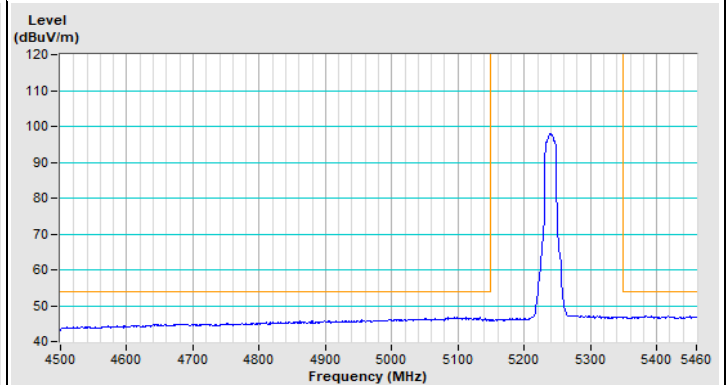

Vertical (Average)

802.11a Channel 52

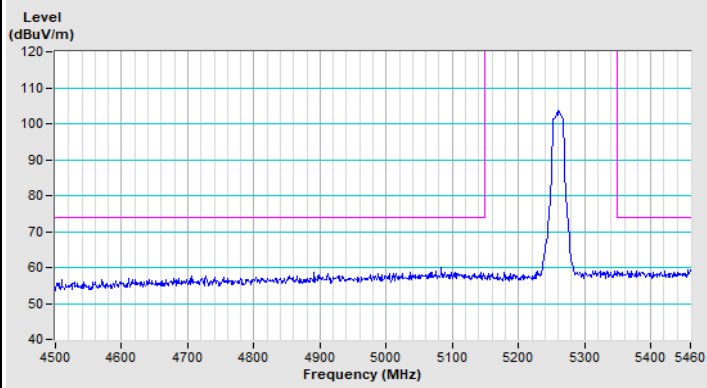

Horizontal (Peak)

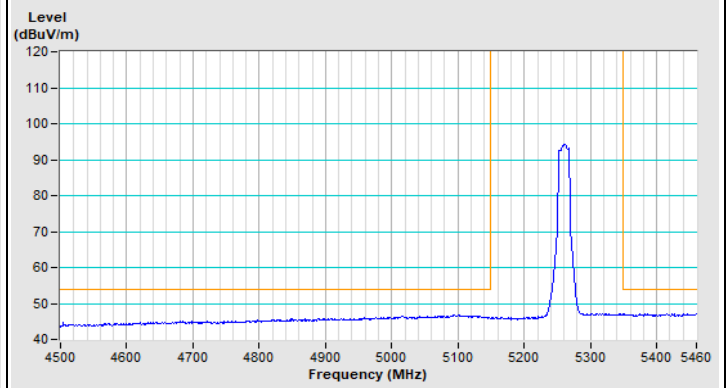

Horizontal (Average)

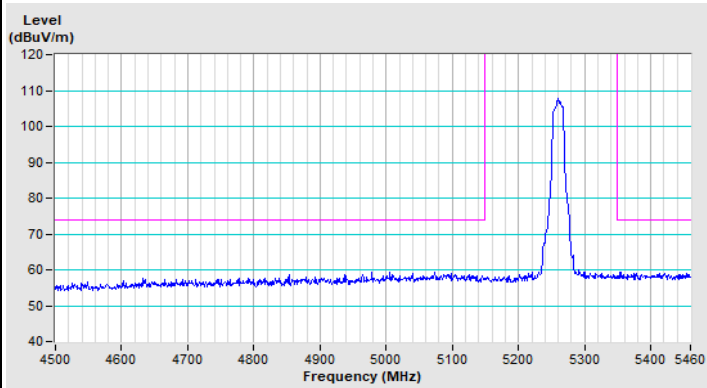

Vertical (Peak)

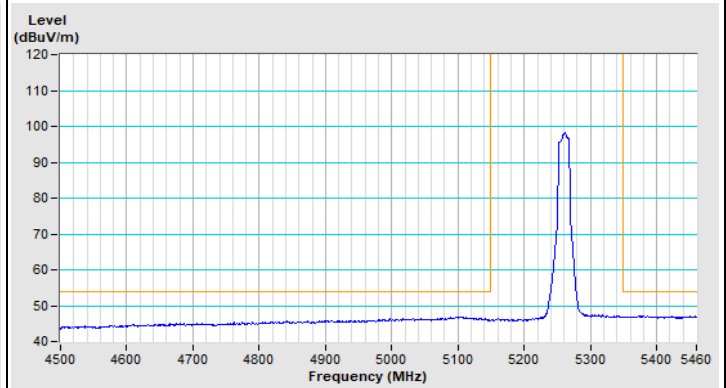

Vertical (Average)

802.11a Channel 64

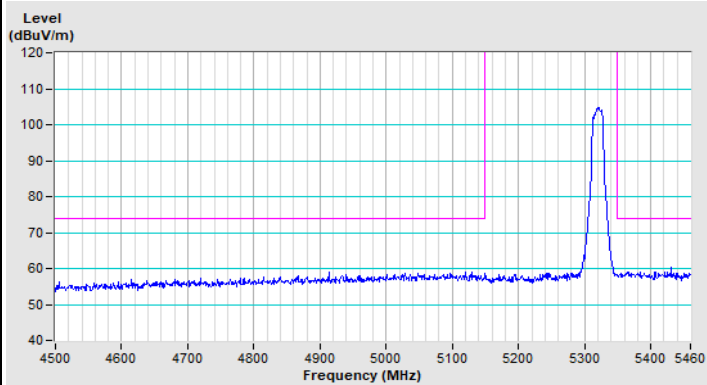

Horizontal (Peak)

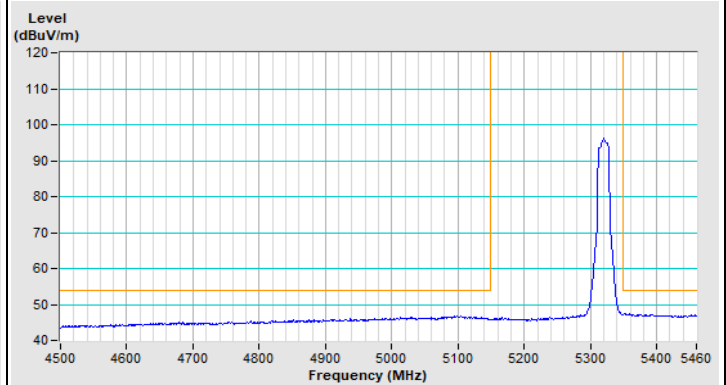

Horizontal (Average)

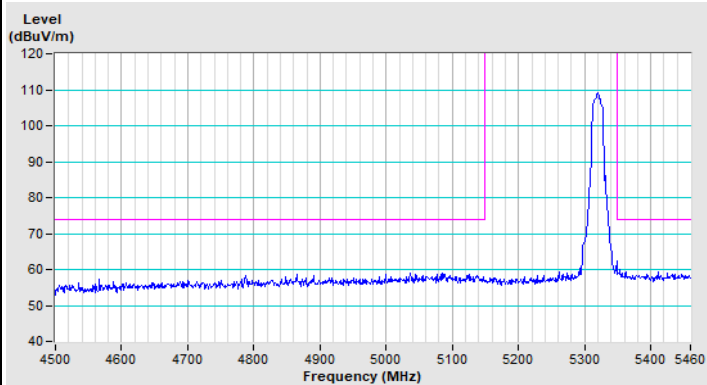

Vertical (Peak)

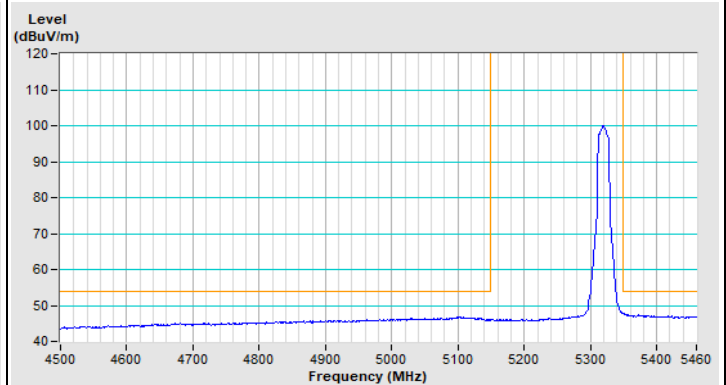

Vertical (Average)

802.11a Channel 100

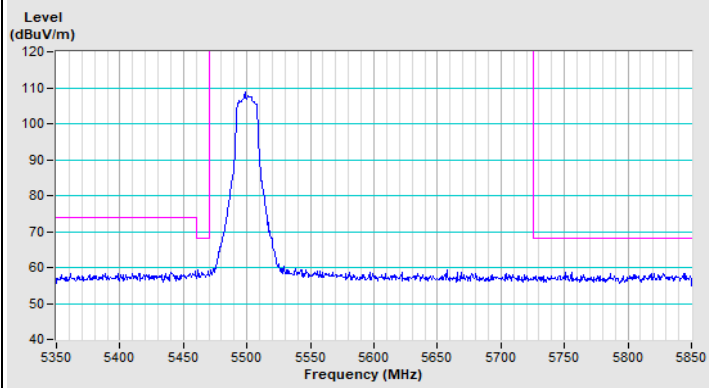

Horizontal (Peak)

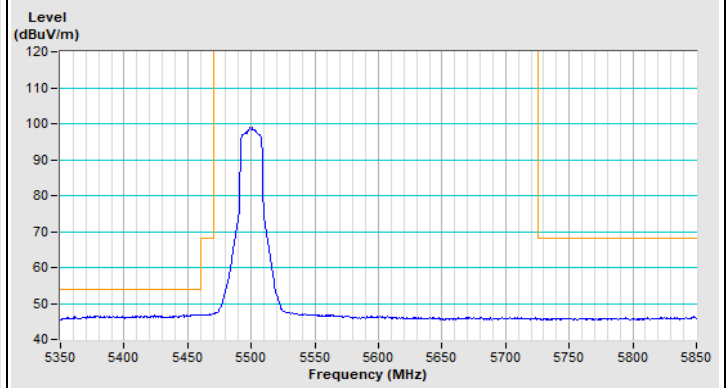

Horizontal (Average)

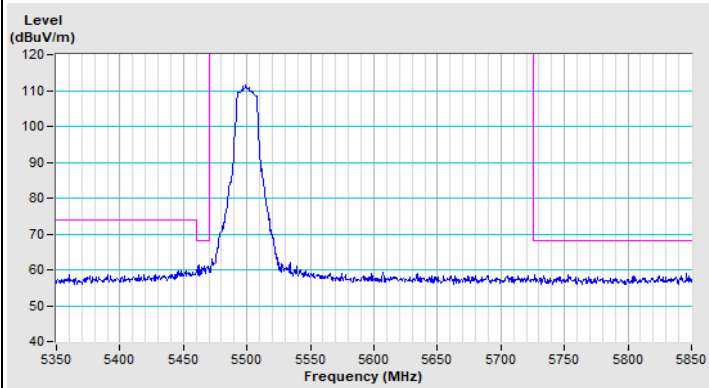

Vertical (Peak)

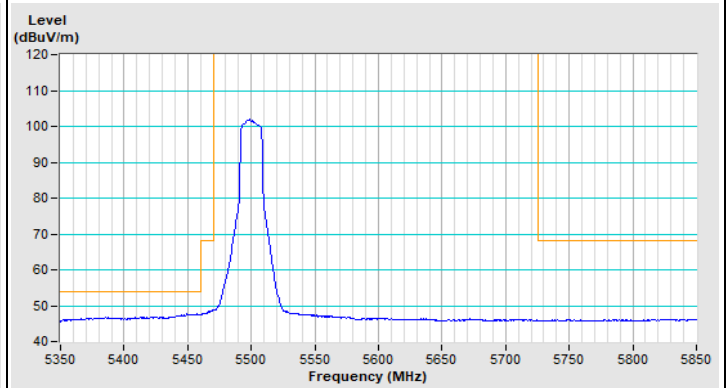

Vertical (Average)

802.11a Channel 140

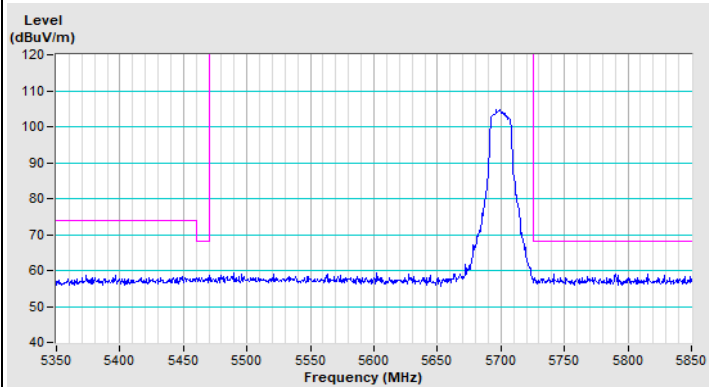

Horizontal (Peak)

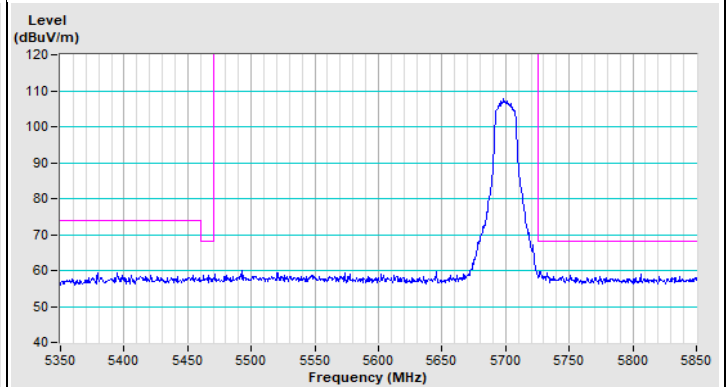

Vertical (Peak)

802.11a Channel 149

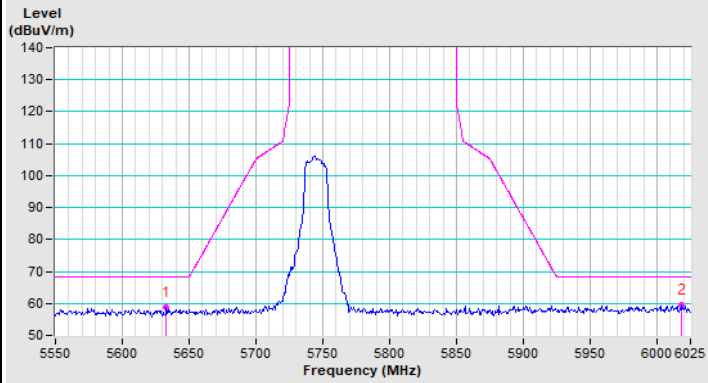

Horizontal (Peak)

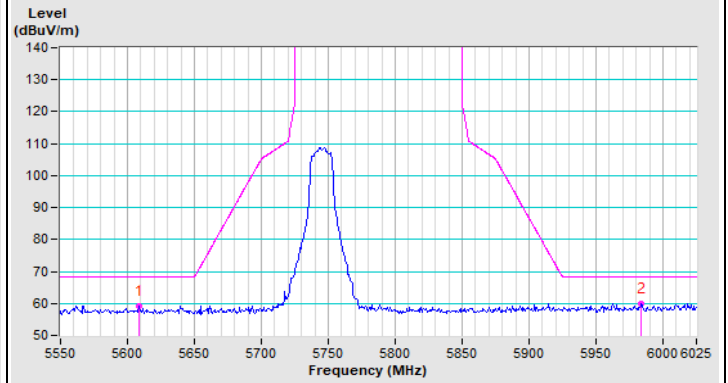

Vertical (Peak)

802.11a Channel 157

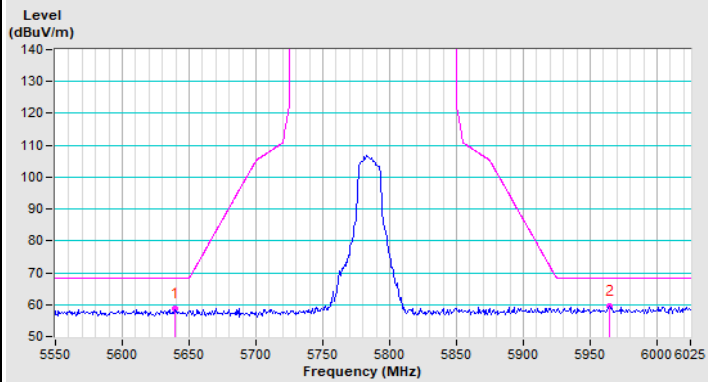

Horizontal (Peak)

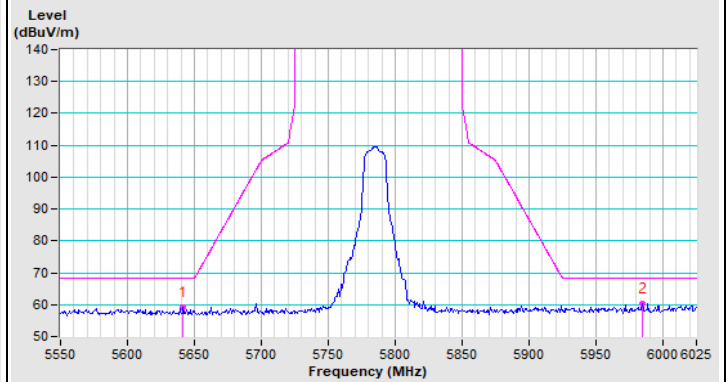

Vertical (Peak)

802.11a Channel 165

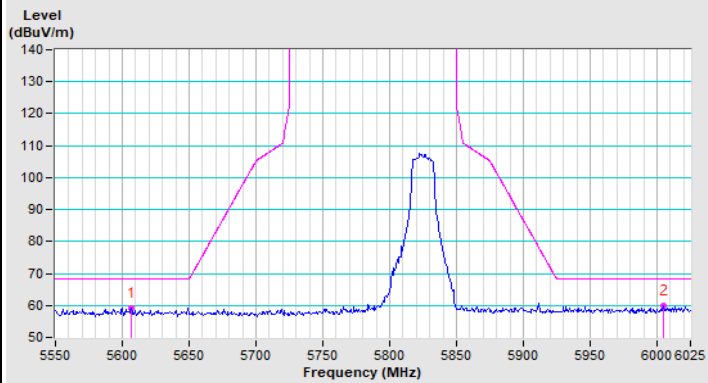

Horizontal (Peak)

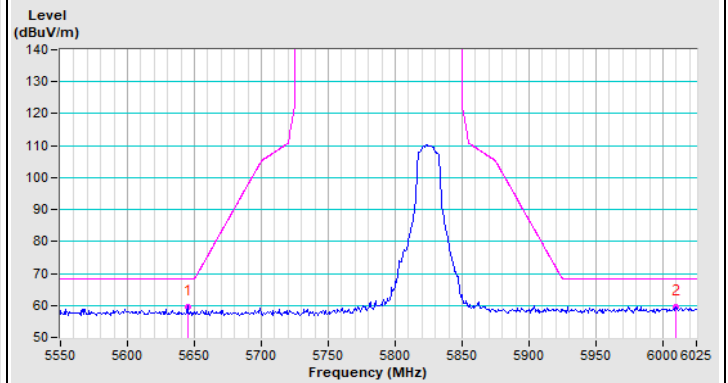

Vertical (Peak)

802.11ac (VHT20) Channel 36

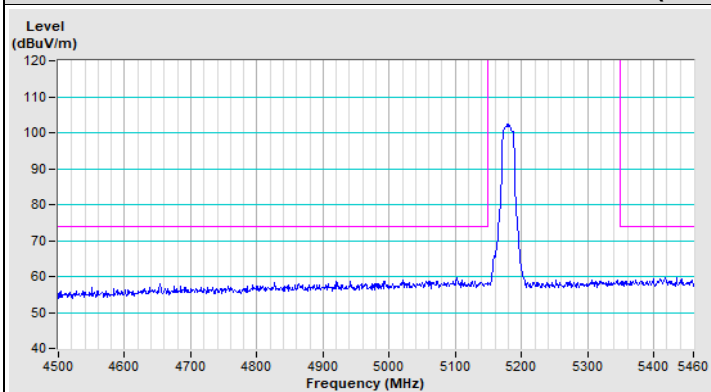

Horizontal (Peak)

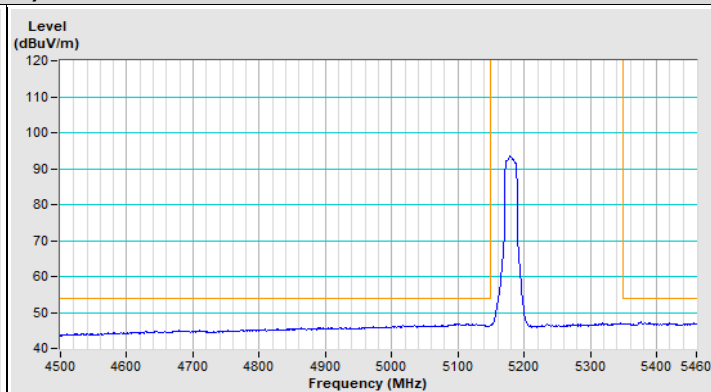

Horizontal (Average)

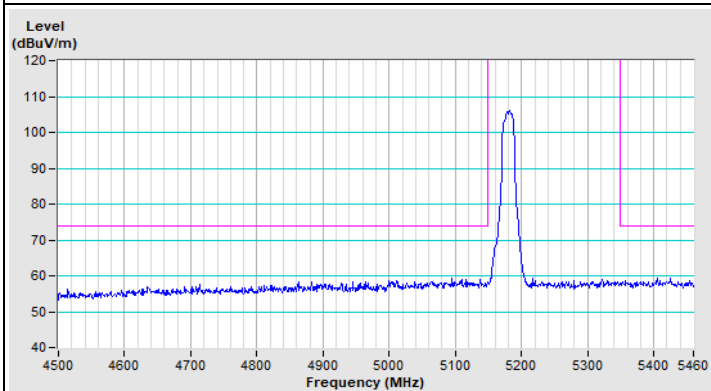

Vertical (Peak)

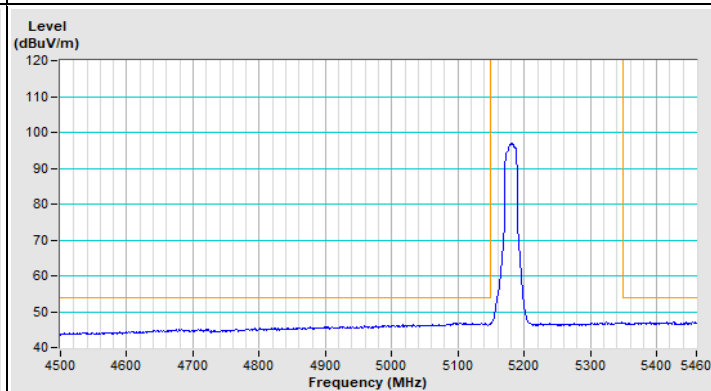

Vertical (Average)

802.11ac (VHT20) Channel 48

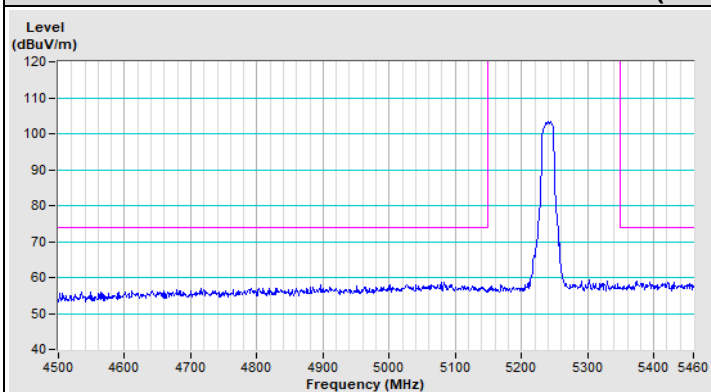

Horizontal (Peak)

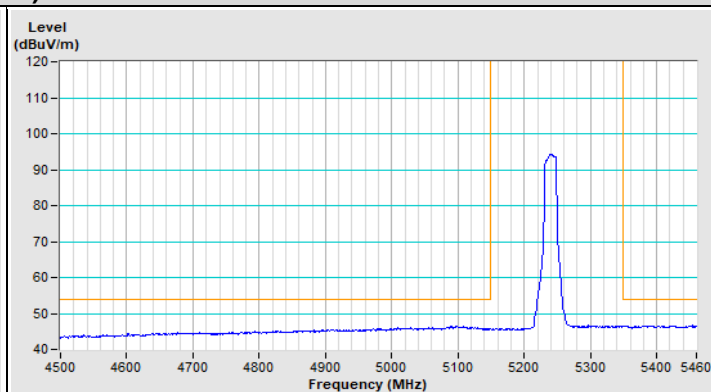

Horizontal (Average)

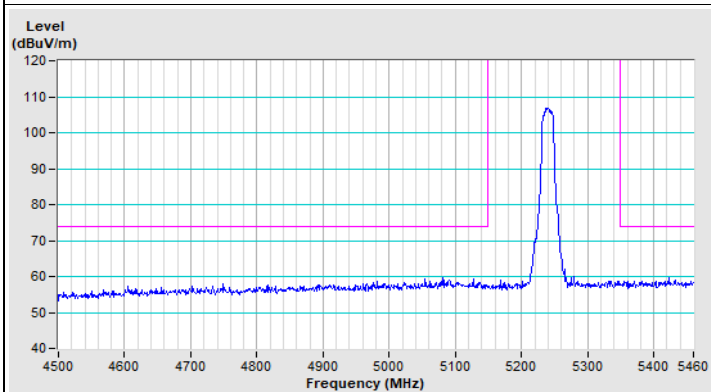

Vertical (Peak)

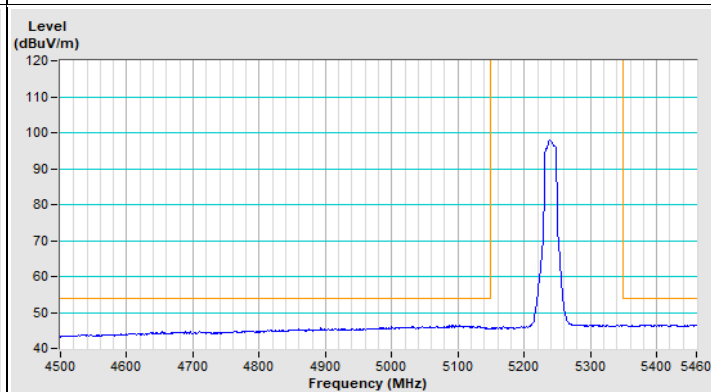

Vertical (Average)

802.11ac (VHT20) Channel 52

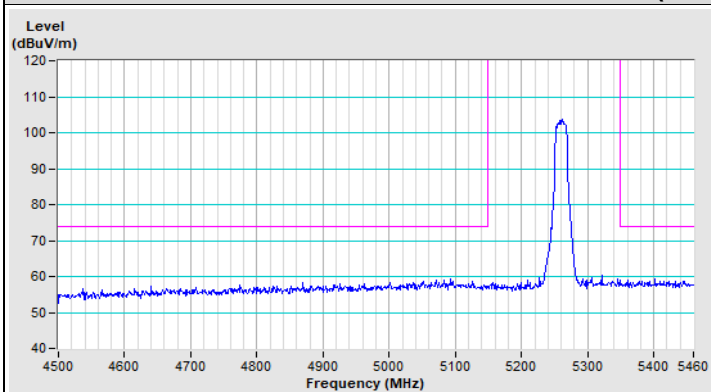

Horizontal (Peak)

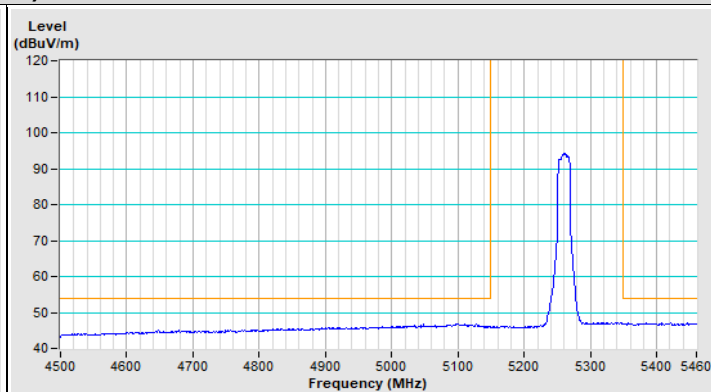

Horizontal (Average)

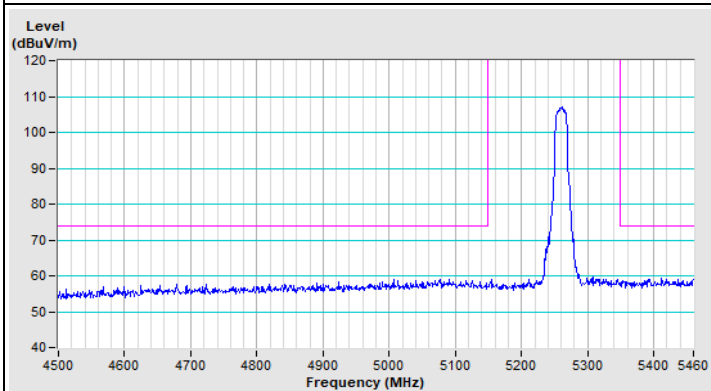

Vertical (Peak)

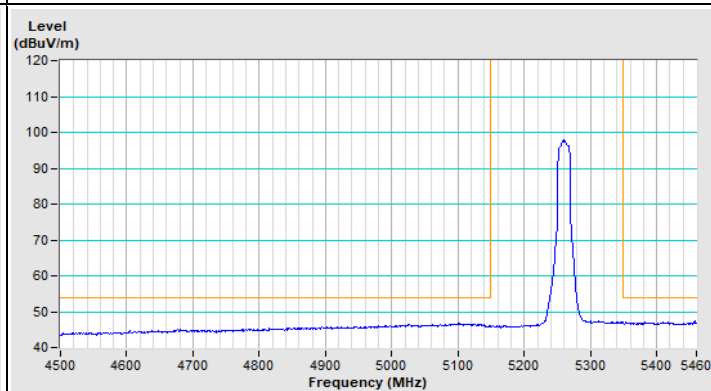

Vertical (Average)

802.11ac (VHT20) Channel 64

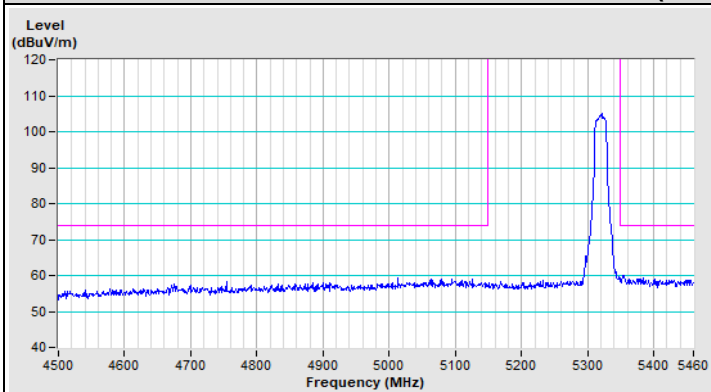

Horizontal (Peak)

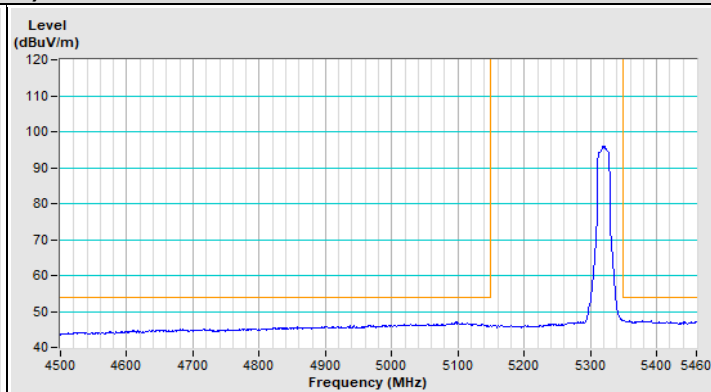

Horizontal (Average)

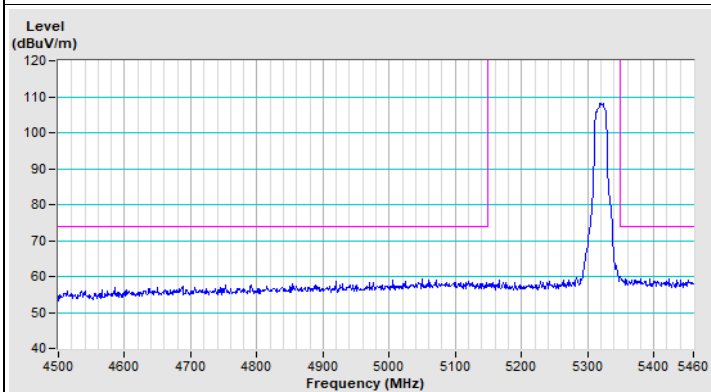

Vertical (Peak)

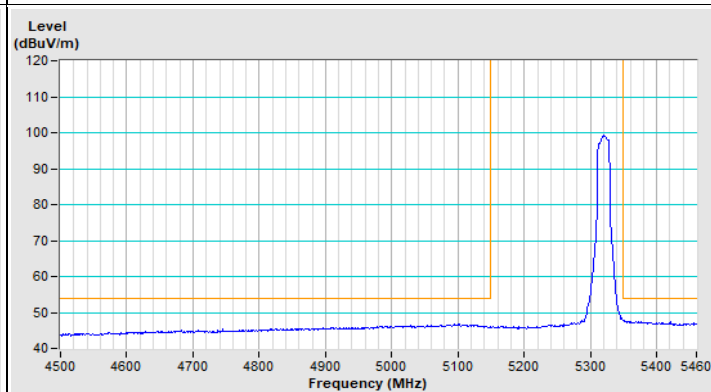

Vertical (Average)

802.11ac (VHT20) Channel 100

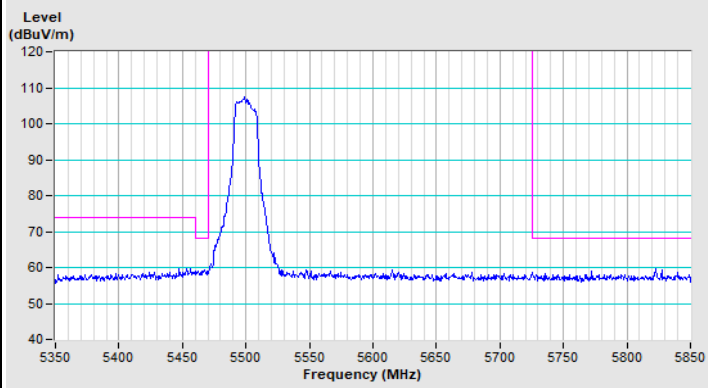

Horizontal (Peak)

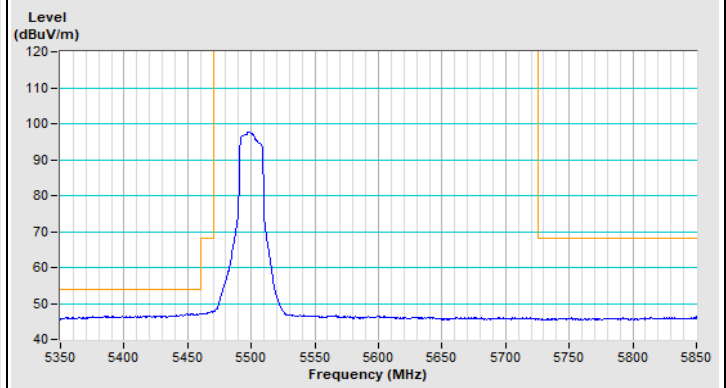

Horizontal (Average)

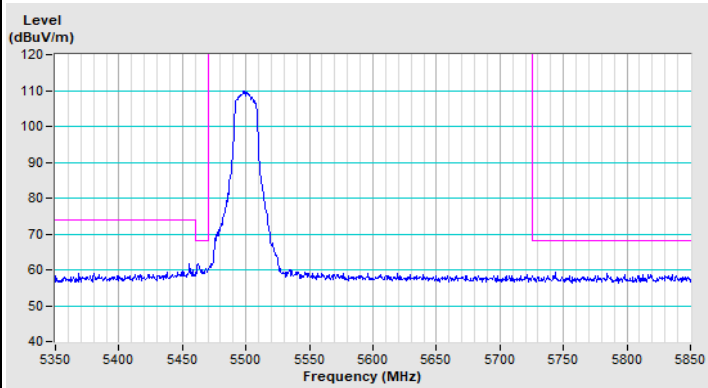

Vertical (Peak)

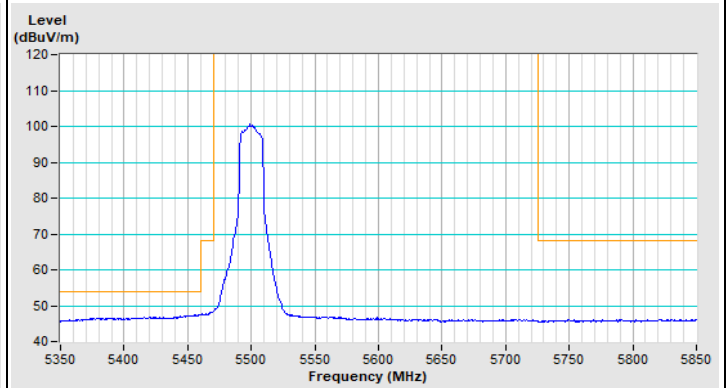

Vertical (Average)

802.11ac (VHT20) Channel 140

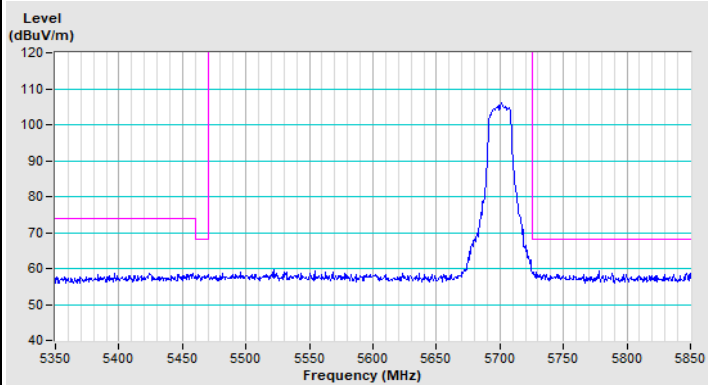

Horizontal (Peak)

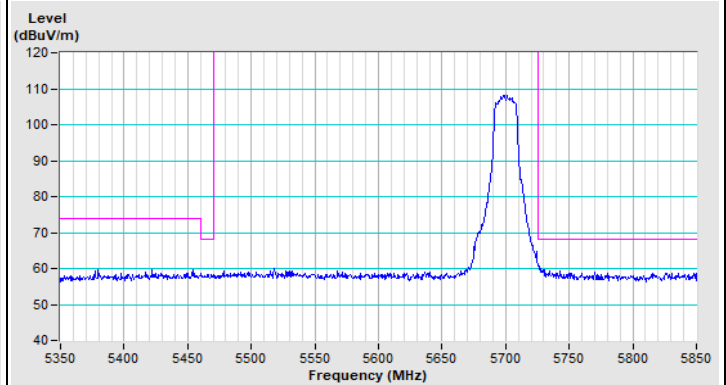

Vertical (Peak)

802.11ac (VHT20) Channel 149

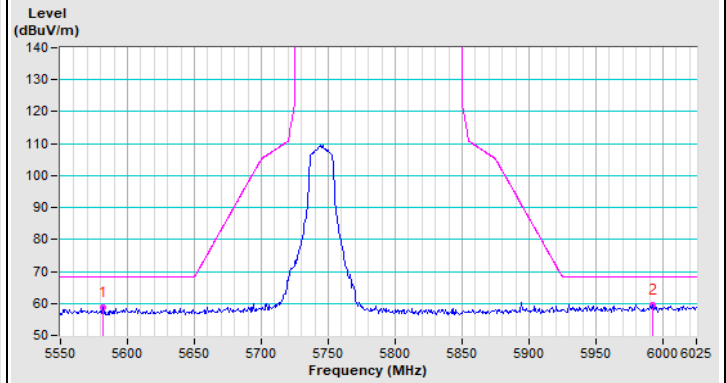
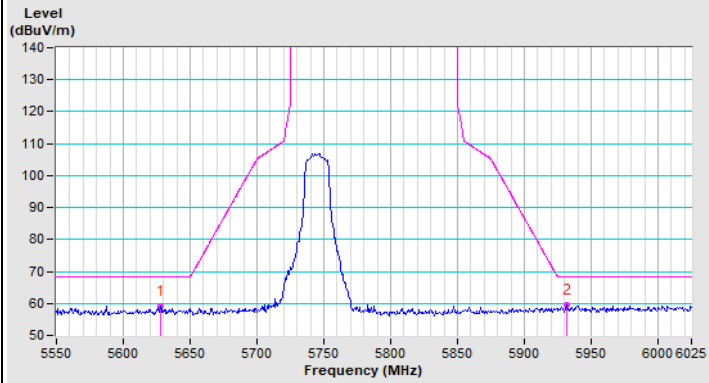

802.11ac (VHT20) Channel 157

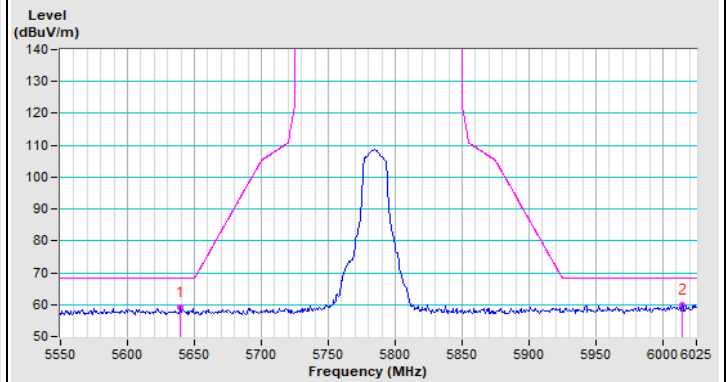
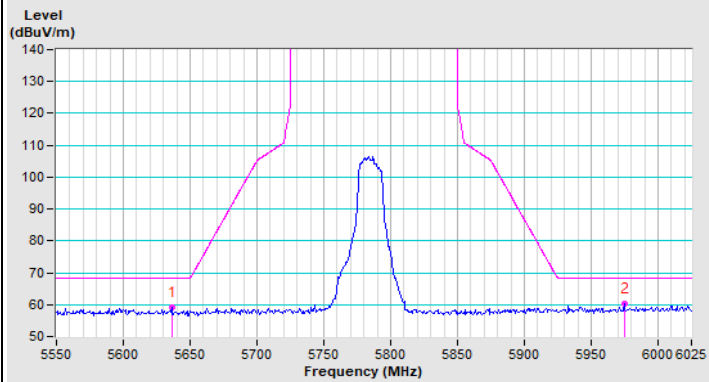

802.11ac (VHT20) Channel 165

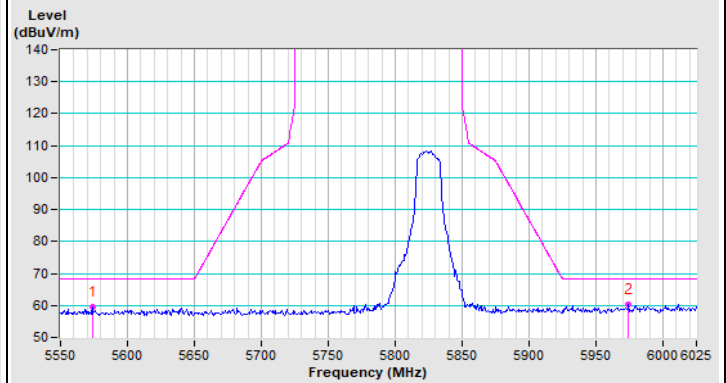
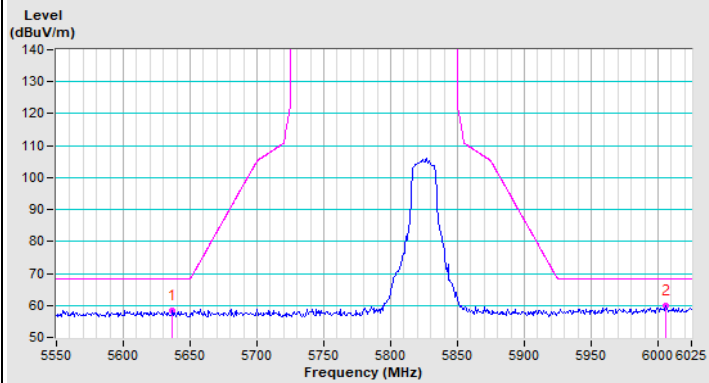

802.11ac (VHT40) Channel 38

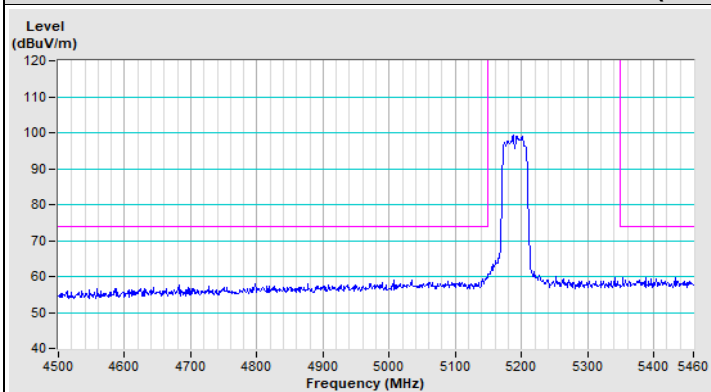

Horizontal (Peak)

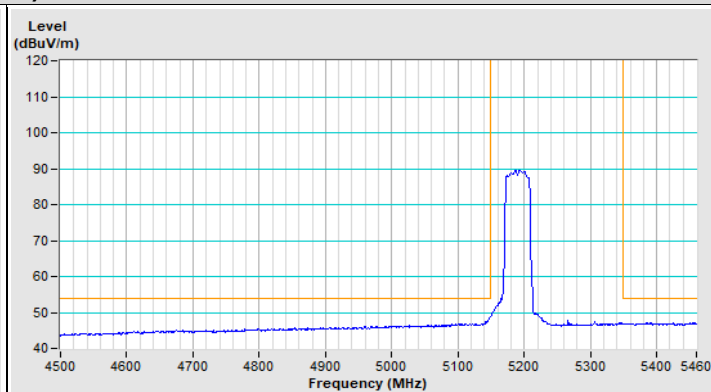

Horizontal (Average)

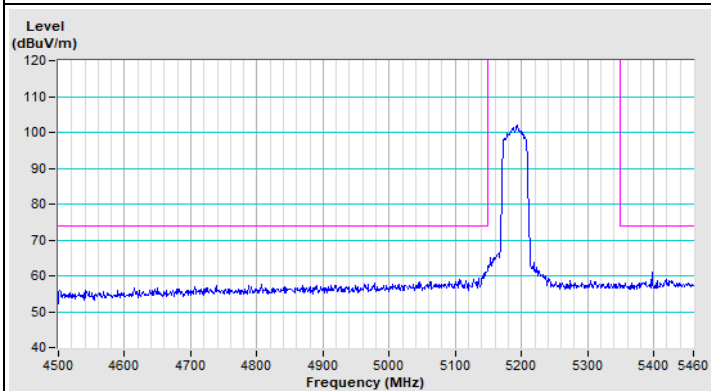

Vertical (Peak)

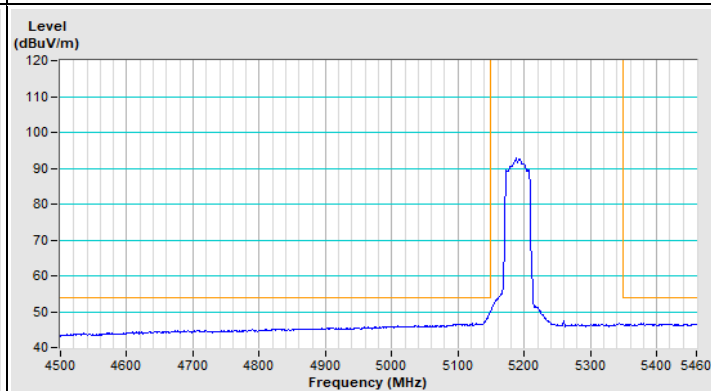

Vertical (Average)

802.11ac (VHT40) Channel 46

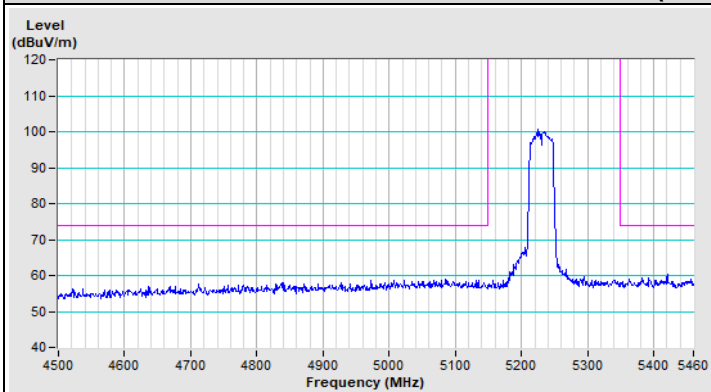

Horizontal (Peak)

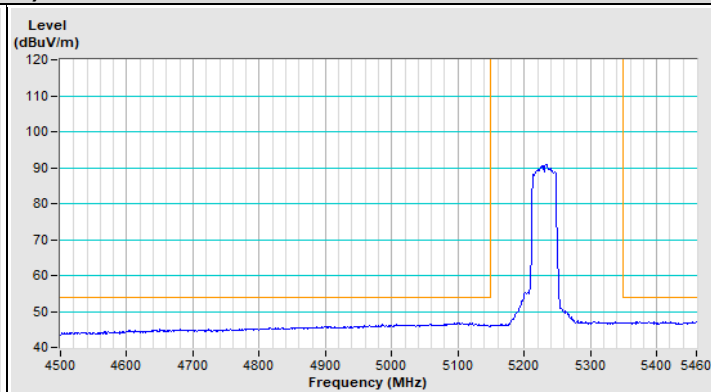

Horizontal (Average)

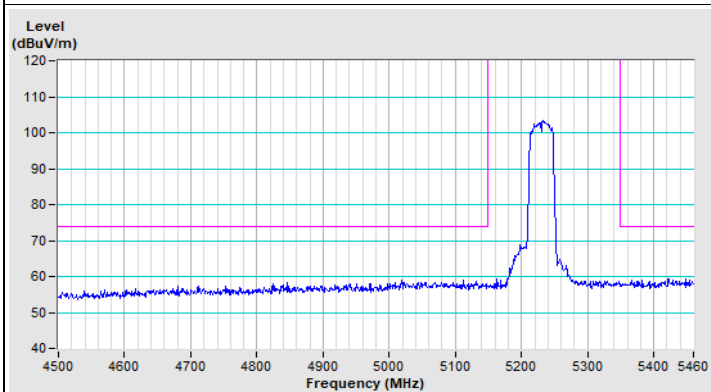

Vertical (Peak)

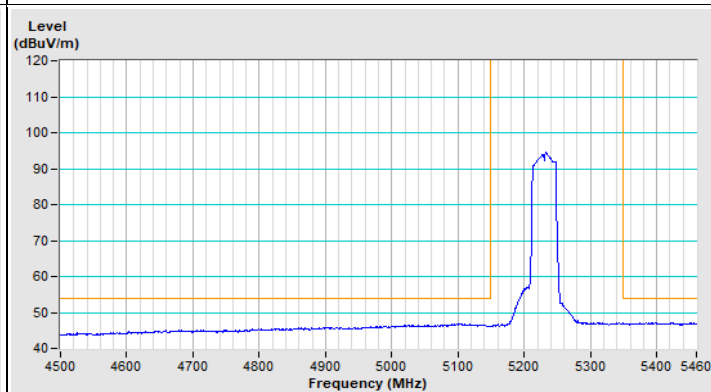

Vertical (Average)

802.11ac (VHT40) Channel 54

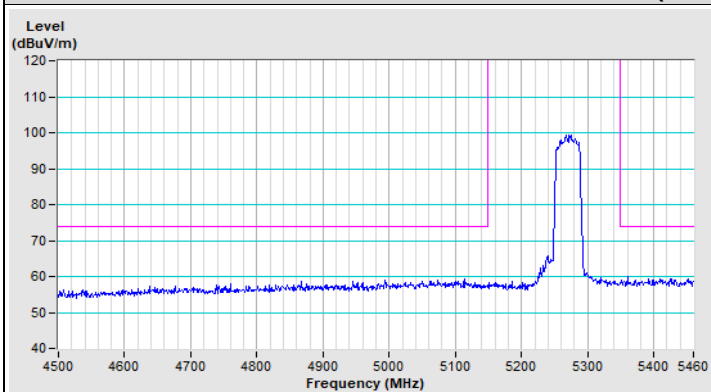

Horizontal (Peak)

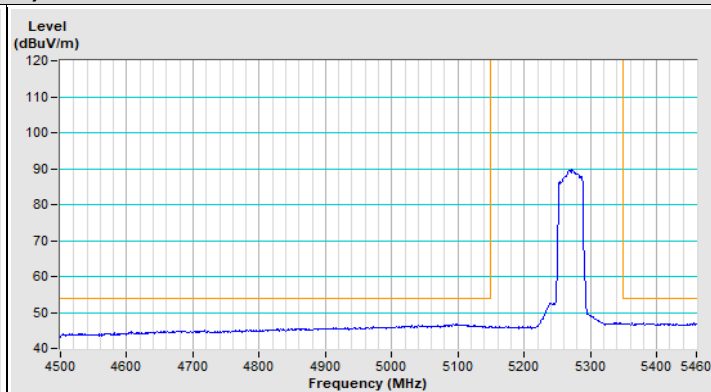

Horizontal (Average)

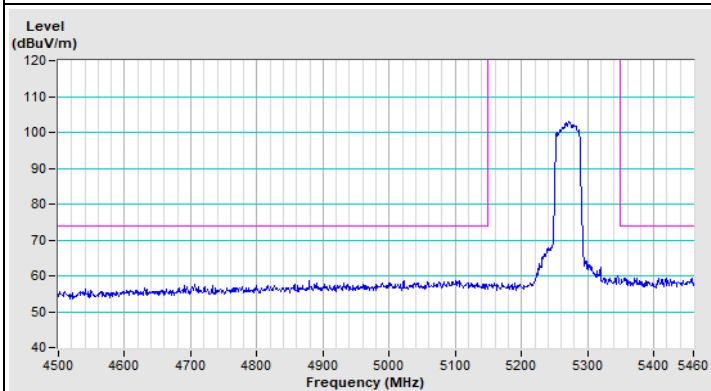

Vertical (Peak)

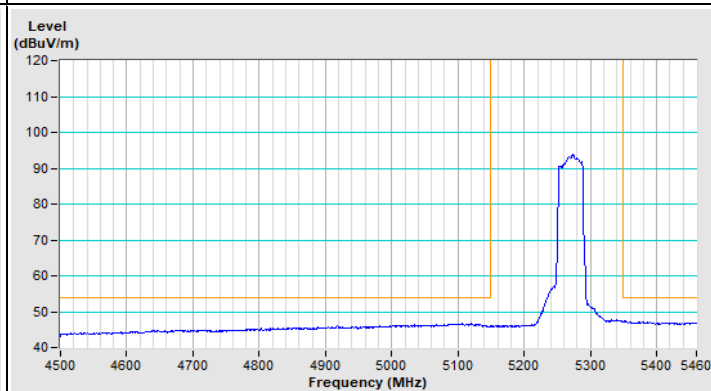

Vertical (Average)

802.11ac (VHT40) Channel 62

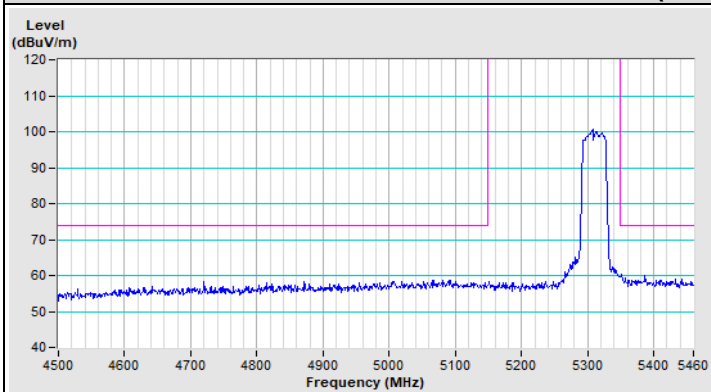

Horizontal (Peak)

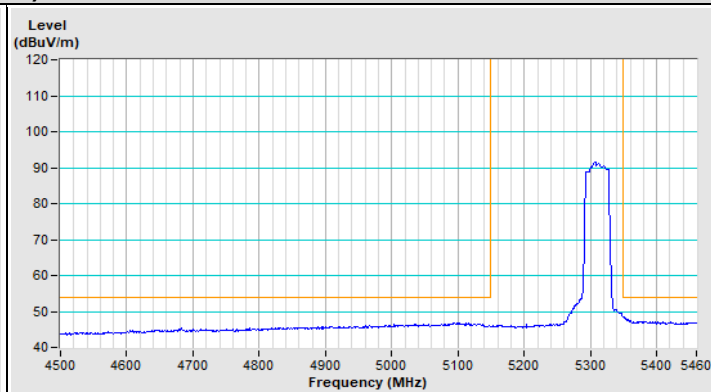

Horizontal (Average)

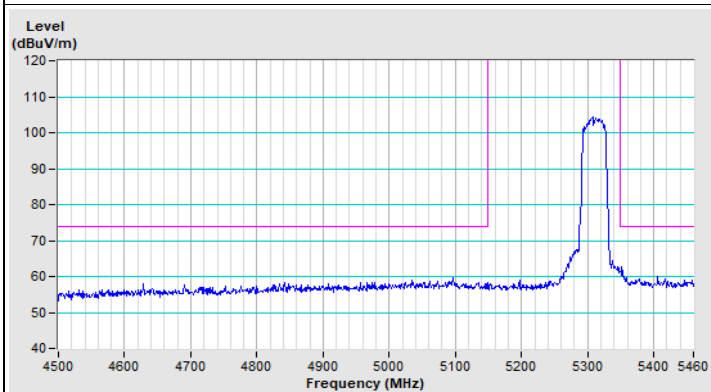

Vertical (Peak)

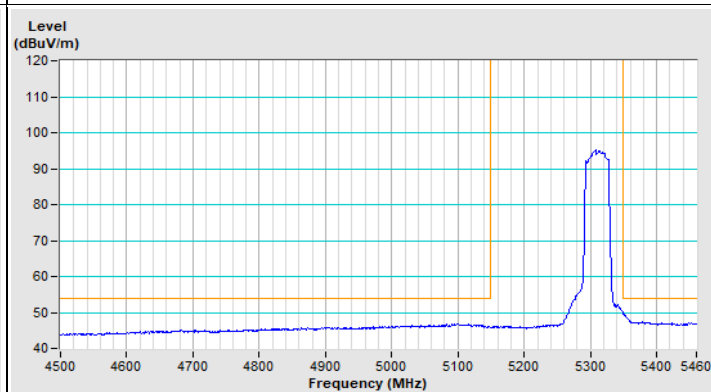

Vertical (Average)

802.11ac (VHT40) Channel 102

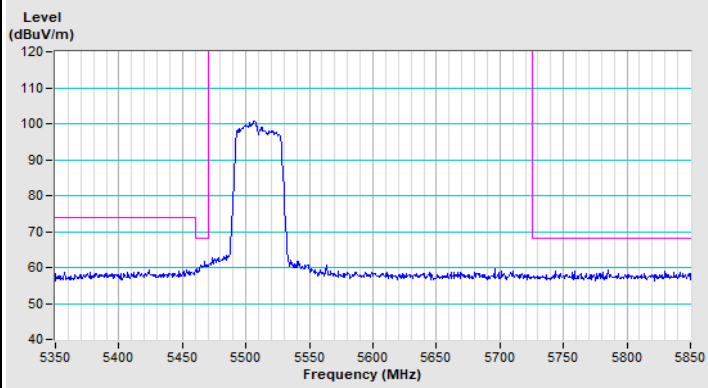

Horizontal (Peak)

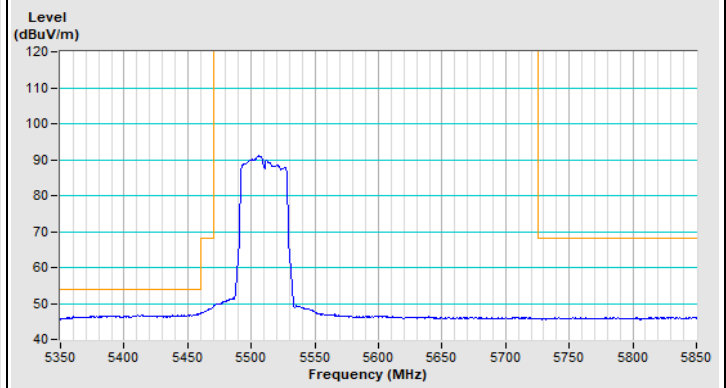

Horizontal (Average)

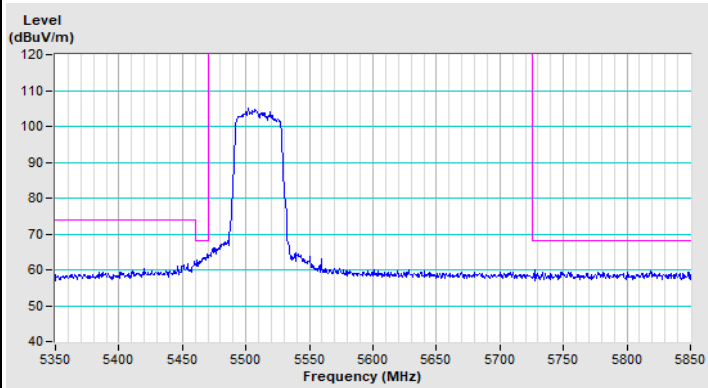

Vertical (Peak)

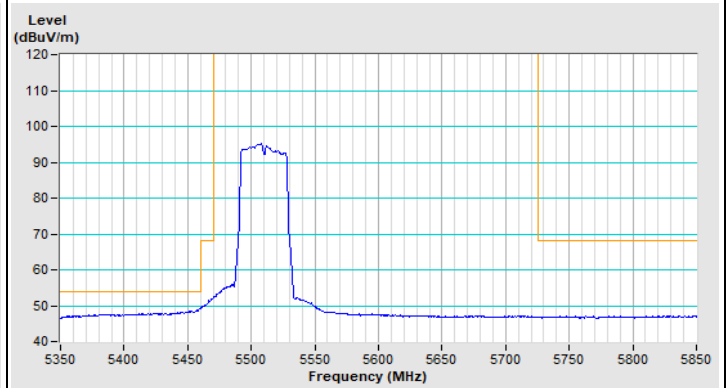

Vertical (Average)

802.11ac (VHT40) Channel 134

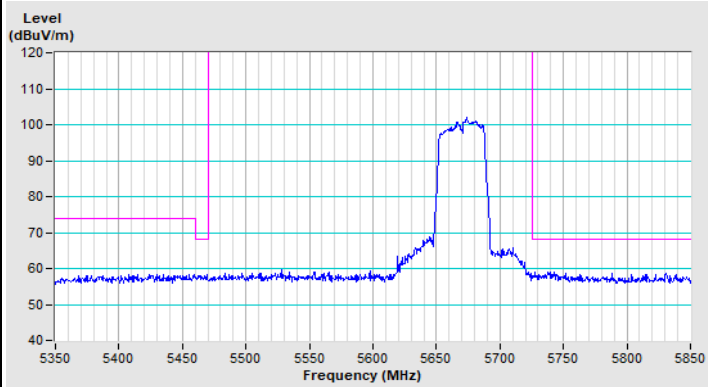

Horizontal (Peak)

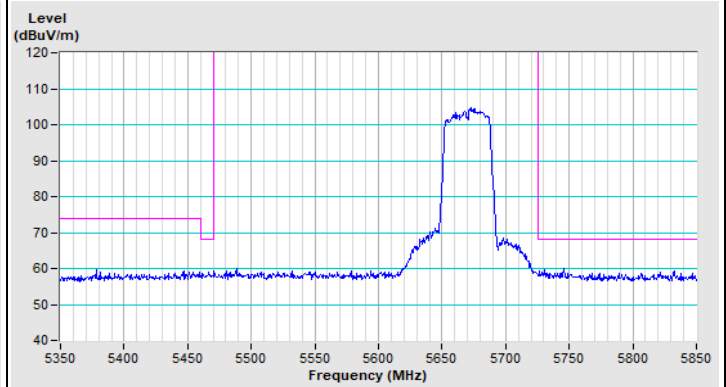

Vertical (Peak)

802.11ac (VHT40) Channel 151

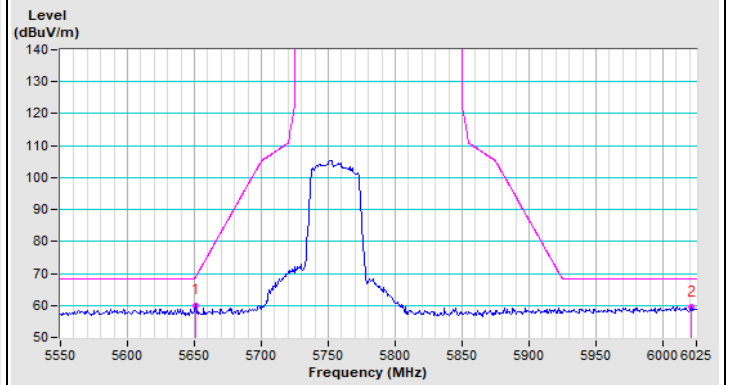
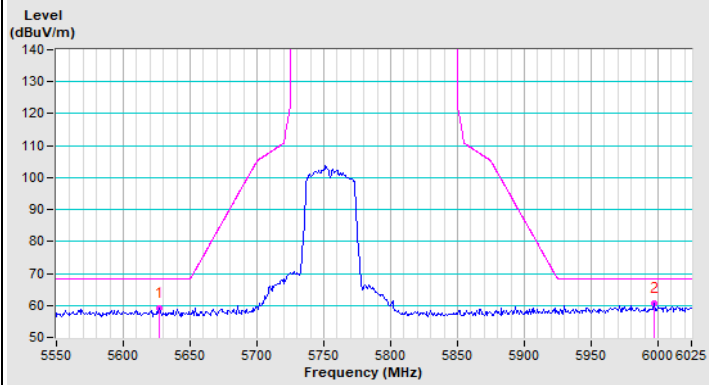

802.11ac (VHT40) Channel 159

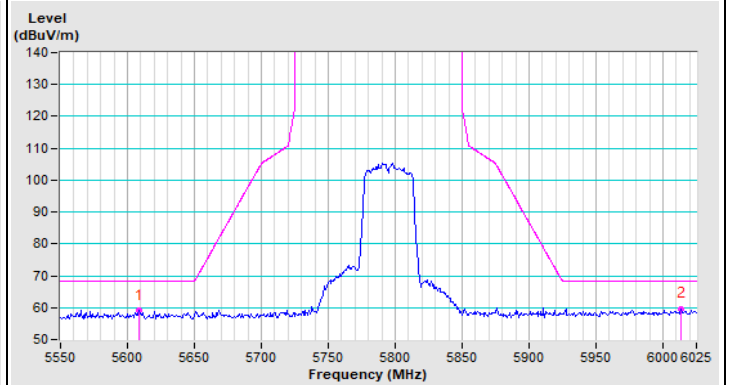
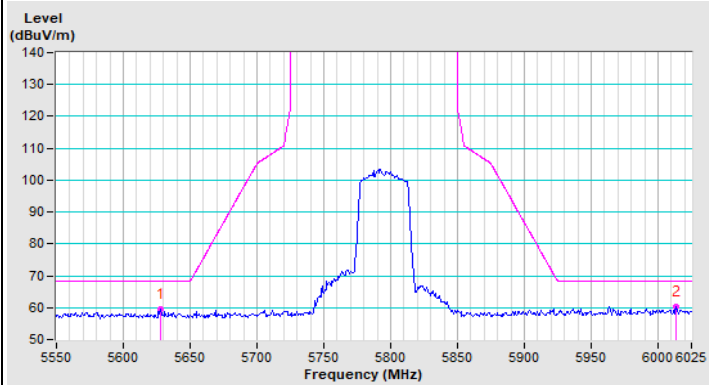

802.11ac (VHT80) Channel 42

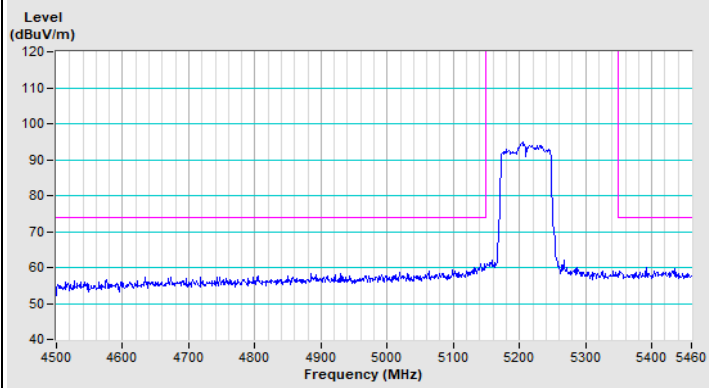

Horizontal (Peak)

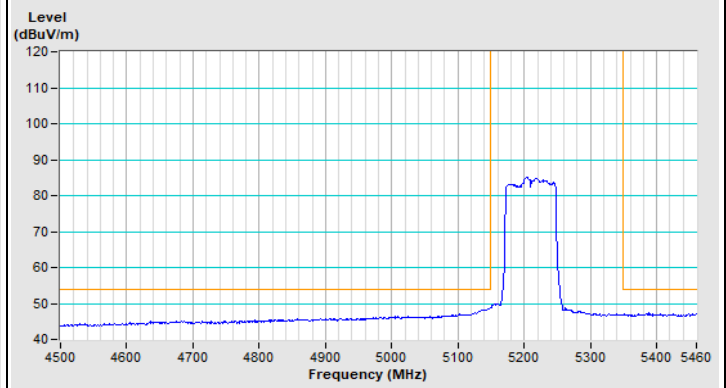

Horizontal (Average)

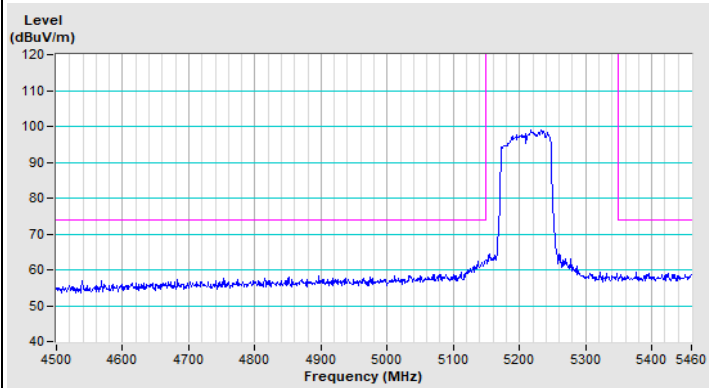

Vertical (Peak)

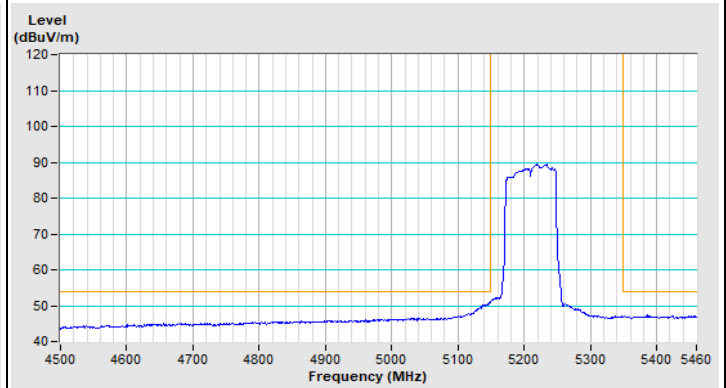

Vertical (Average)

802.11ac (VHT80) Channel 58

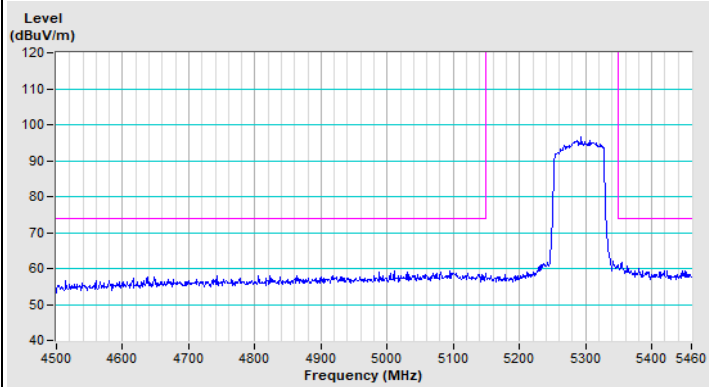

Horizontal (Peak)

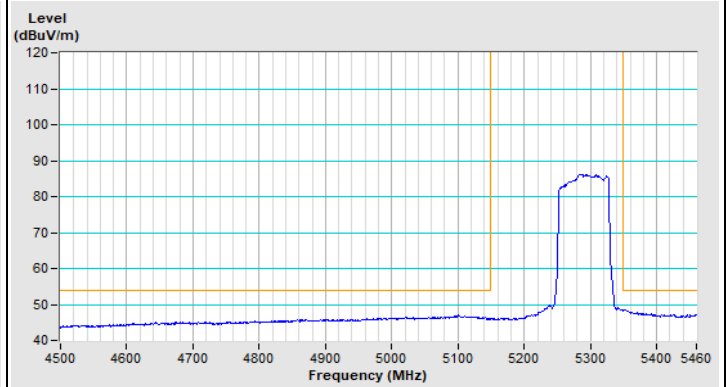

Horizontal (Average)

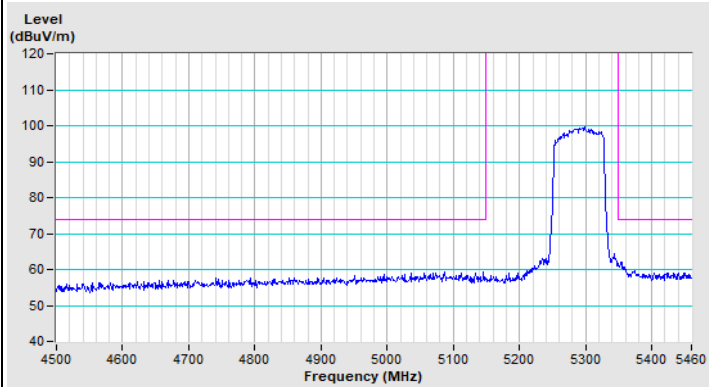

Vertical (Peak)

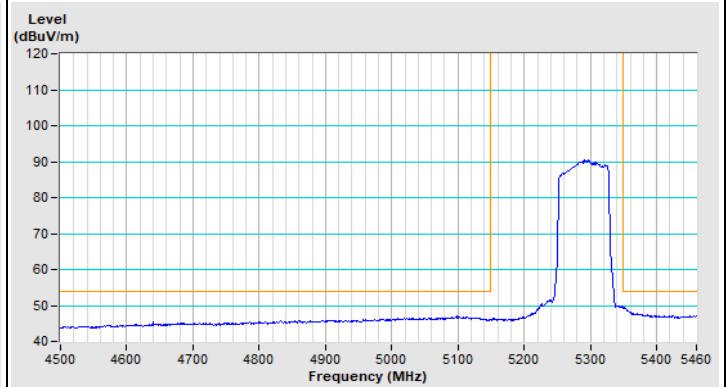

Vertical (Average)



802.11ac (VHT80) Channel 106

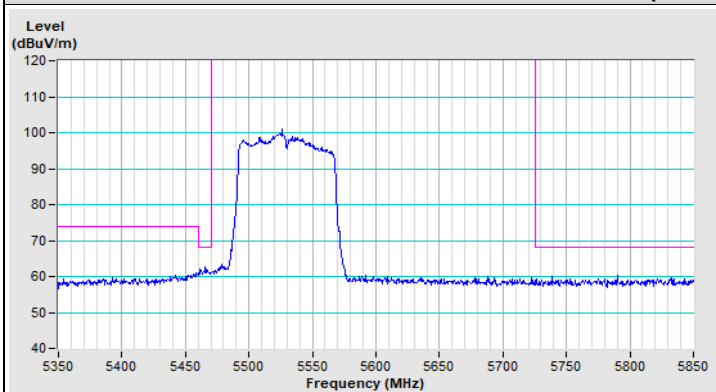

Horizontal (Peak)

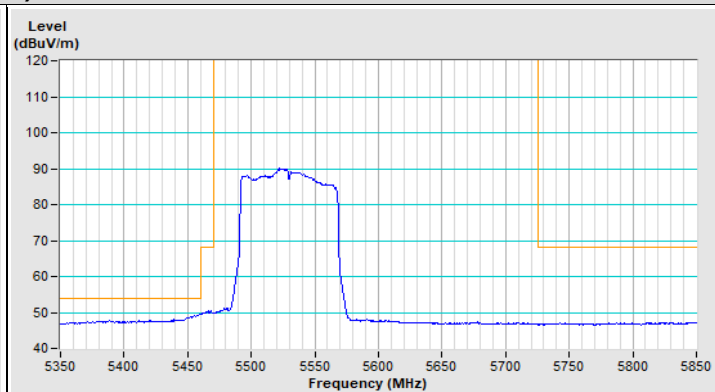

Horizontal (Average)

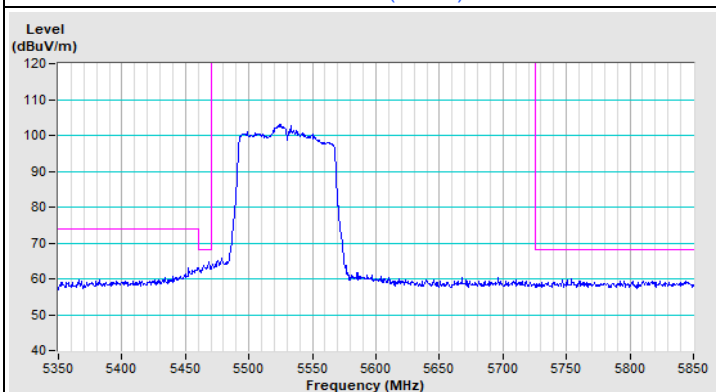

Vertical (Peak)

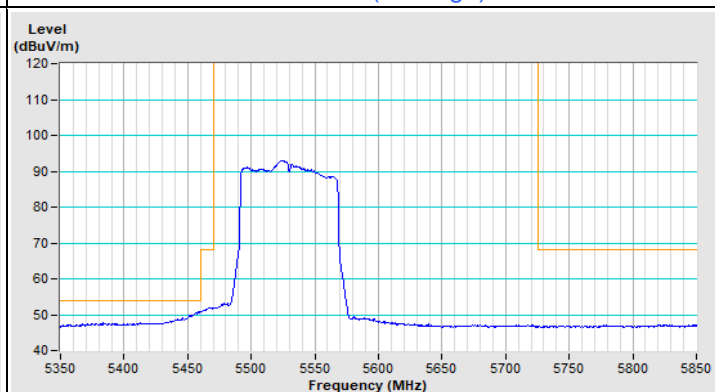

Vertical (Average)

802.11ac (VHT80) Channel 122

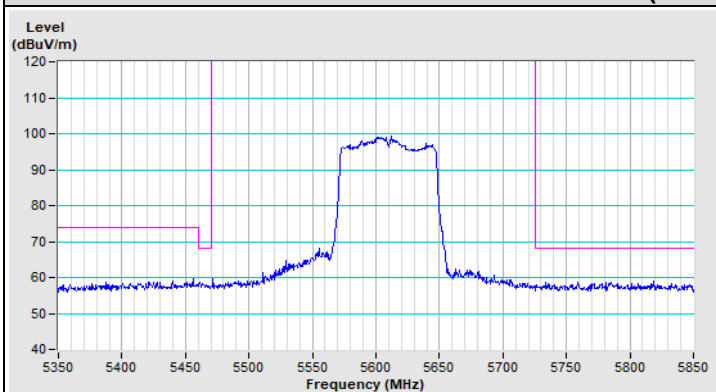

Horizontal (Peak)

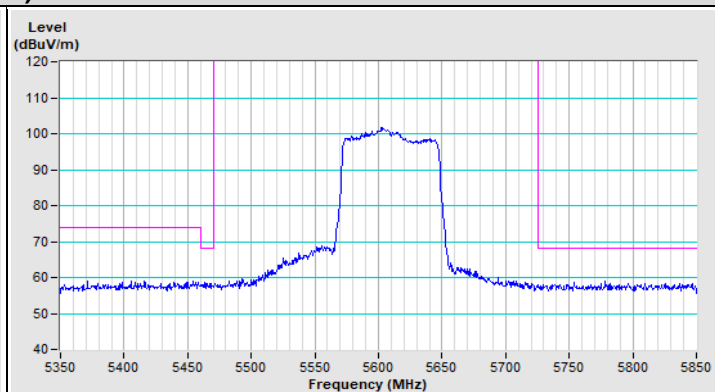

Vertical (Peak)

802.11ac (VHT80) Channel 155

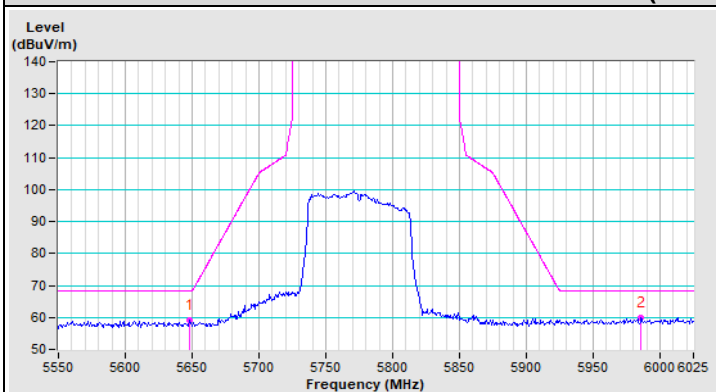

Horizontal (Peak)

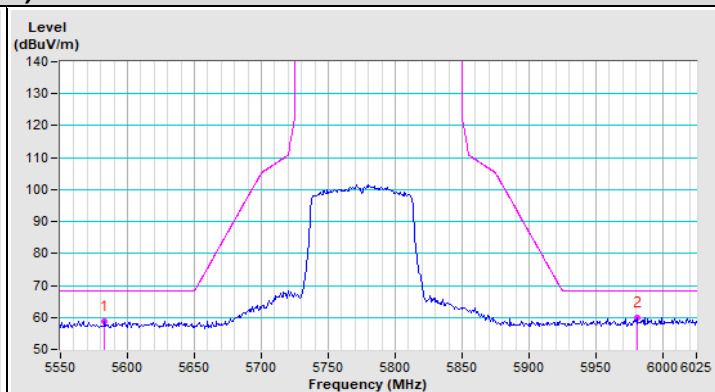

Vertical (Peak)

8 Pictures of Test Arrangements

Please refer to the attached file (Test Setup Photo)

9 Information of the Testing Laboratories

We, Bureau Veritas Consumer Products Services (H.K.) Ltd., Taoyuan Branch, were founded in 1988 to provide our best service in EMC, Radio, Telecom and Safety consultation. Our laboratories are FCC recognized accredited test firms and accredited according to ISO/IEC 17025.

If you have any comments, please feel free to contact us at the following:

Lin Kou EMC/RF Lab

Tel: 886-2-26052180

Fax: 886-2-26051924

Hsin Chu EMC/RF/Telecom Lab

Tel: 886-3-6668565

Fax: 886-3-6668323

Hwa Ya EMC/RF/Safety Lab

Tel: 886-3-3183232

Fax: 886-3-3270892

Email: service.adt@bureauveritas.com

Web Site: <http://ee.bureauveritas.com.tw>

The address and road map of all our labs can be found in our web site also.

--- END ---