



TEST REPORT

Test report no.: 1-1910/21-01-14

BNetzA-CAB-02/21-102

Testing laboratory

CTC advanced GmbH

Untertuerkheimer Strasse 6 – 10

66117 Saarbruecken / Germany

Phone: + 49 681 5 98 - 0

Fax: + 49 681 5 98 - 9075

Internet: <https://www.ctcadvanced.com>

e-mail: mail@ctcadvanced.com

Accredited Testing Laboratory:

The testing laboratory (area of testing) is accredited according to DIN EN ISO/IEC 17025 (2018-03) by the Deutsche Akkreditierungsstelle GmbH (DAkkS)

The accreditation is valid for the scope of testing procedures as stated in the accreditation certificate starting with the registration number: D-PL-12076-01.

Applicant

Sennheiser electronic GmbH & Co. KG

Am Labor 1

30900 Wedemark / GERMANY

Phone: +49 5130 600-0

Contact: Nils Knauer

e-mail: Nils.Knauer@sennheiser.com

Manufacturer

Sennheiser electronic GmbH & Co. KG

Am Labor 1

30900 Wedemark / GERMANY

Test standard/s

FCC - Title 47 CFR Part 74 FCC - Title 47 of the Code of Federal Regulations; Chapter I; Part 74 - Experimental radio, auxiliary, special broadcast and other program distributional services

RSS - 210 Issue 10 Spectrum Management and Telecommunications Radio Standards Specification - Licence-Exempt Radio Apparatus: Category I Equipment

For further applied test standards please refer to section 3 of this test report.

Test Item

Test item description: **Plug-On Transmitter**

Model No.: **EW-DP SKP**

FCC ID: **DMOSKPEWDP**

ISED certification number: **2099A-SKPEWDP**

Frequency: 470.2 MHz to 607.8 MHz

Technology tested: proprietary

Antenna: Internal dipole antenna

Power supply: 2.0 V to 4.35 V DC by battery Li-Ion BA 70 or 2x AA type 1.50 V DC

Temperature range: -10°C to +55°C

This test report is electronically signed and valid without handwritten signature. For verification of the electronic signatures, the public keys can be requested at the testing laboratory.

Test report authorized:



Christoph Schneider
Lab Manager
Radio Labs

Test performed:



Joachim Wolsdorfer
Lab Manager
Radio Labs

1 Table of contents

1	Table of contents	2
2	General information	3
2.1	Notes and disclaimer	3
2.2	Application details	3
2.3	Test laboratories sub-contracted	3
3	Test standard/s, references and accreditations	4
4	Reporting statements of conformity – decision rule	5
5	Test environment	6
6	Test item.....	6
6.1	General description	6
6.2	Additional information	7
7	Description of the test setup.....	7
7.1	Shielded fully anechoic chamber.....	8
7.2	Conducted measurements normal and extreme conditions.....	9
8	Sequence of testing	10
8.1	Sequence of testing radiated spurious 30 MHz to 12.75 GHz	10
9	Measurement uncertainty	11
10	Summary of measurement results.....	12
11	Additional comments	13
12	Measurement results.....	14
12.1	Transmitter output power.....	14
12.2	Occupied bandwidth	21
12.3	Transmitter frequency stability	27
12.4	Transmitter unwanted emissions (radiated).....	32
12.5	Necessary bandwidth (BN) for digital systems.....	39
13	Observations.....	43
14	Glossary	44
15	Document history	45
16	Accreditation Certificate – D-PL-12076-01-04	45
17	Accreditation Certificate – D-PL-12076-01-05	46

2 General information

2.1 Notes and disclaimer

The test results of this test report relate exclusively to the test item specified in this test report. CTC advanced GmbH does not assume responsibility for any conclusions and generalizations drawn from the test results with regard to other specimens or samples of the type of the equipment represented by the test item.

The test report may only be reproduced or published in full. Reproduction or publication of extracts from the report requires the prior written approval of CTC advanced GmbH.

The testing service provided by CTC advanced GmbH has been rendered under the current "General Terms and Conditions for CTC advanced GmbH".

CTC advanced GmbH will not be liable for any loss or damage resulting from false, inaccurate, inappropriate or incomplete product information provided by the customer.

Under no circumstances does the CTC advanced GmbH test report include any endorsement or warranty regarding the functionality, quality or performance of any other product or service provided.

Under no circumstances does the CTC advanced GmbH test report include or imply any product or service warranties from CTC advanced GmbH, including, without limitation, any implied warranties of merchantability, fitness for purpose, or non-infringement, all of which are expressly disclaimed by CTC advanced GmbH.

All rights and remedies regarding vendor's products and services for which CTC advanced GmbH has prepared this test report shall be provided by the party offering such products or services and not by CTC advanced GmbH. In no case this test report can be considered as a Letter of Approval.

This test report is electronically signed and valid without handwritten signature. For verification of the electronic signatures, the public keys can be requested at the testing laboratory.

2.2 Application details

Date of receipt of order:	2022-11-08
Date of receipt of test item:	2023-03-30
Start of test:*	2023-04-05
End of test:*	2023-04-26
Person(s) present during the test:	-/-

*Date of each measurement, if not shown in the plot, can be requested. Dates are stored in the measurement software.

2.3 Test laboratories sub-contracted

None

3 Test standard/s, references and accreditations

Test standard	Date	Description
FCC - Title 47 CFR Part 74		FCC - Title 47 of the Code of Federal Regulations; Chapter I; Part 74 - Experimental radio, auxiliary, special broadcast and other program distributional services
RSS - 210 Issue 10	December 2019	Spectrum Management and Telecommunications Radio Standards Specification - Licence-Exempt Radio Apparatus: Category I Equipment
ETSI EN 300 422-1 V1.4.2	2011-08	Electromagnetic compatibility and Radio spectrum Matters (ERM); Wireless microphones in the 25 MHz to 3 GHz frequency range; Part 1: Technical characteristics and methods of measurement

Guidance	Version	Description
ANSI C63.10-2013	-/-	American National Standard of Procedures for Compliance Testing of Unlicensed Wireless Devices

Accreditation	Description
D-PL-12076-01-04	Telecommunication and EMC Canada https://www.dakks.de/as/ast/d/D-PL-12076-01-04e.pdf
D-PL-12076-01-05	Telecommunication FCC requirements https://www.dakks.de/as/ast/d/D-PL-12076-01-05e.pdf



ISED Testing Laboratory Recognized Listing Number: DE0001
 FCC designation number: DE0002

4 Reporting statements of conformity – decision rule

Only the measured values related to their corresponding limits will be used to decide whether the equipment under test meets the requirements of the test standards listed in chapter 3.

The measurement uncertainty is mentioned in this test report, see chapter 9, but is not taken into account - neither to the limits nor to the measurement results. Measurement results with a smaller margin to the corresponding limits than the measurement uncertainty have a potential risk of more than 5% that the decision might be wrong."

measured value, measurement uncertainty, verdict

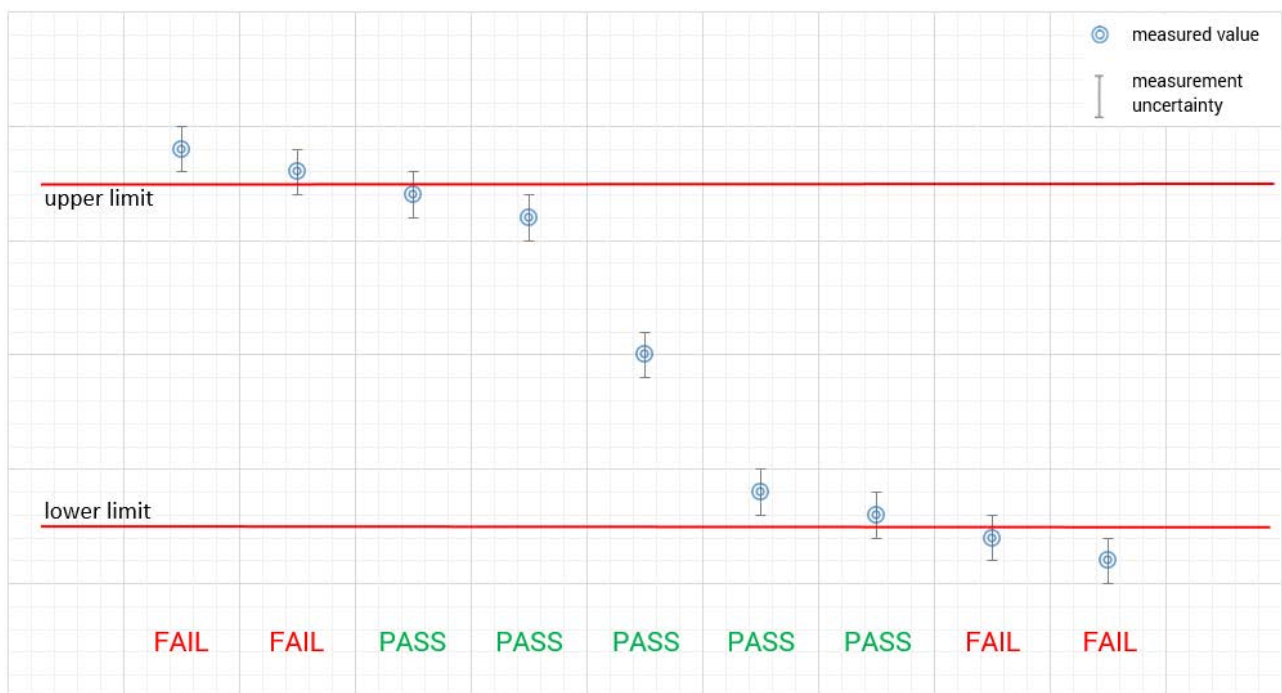

5 Test environment

Temperature	:	T _{nom}	+20 °C during room temperature tests
		T _{max}	+55 °C during high temperature tests
		T _{min}	-10 °C during low temperature tests
Relative humidity content	:		55 %
Barometric pressure	:		1021 hpa
Power supply	:	V _{nom}	3.80 V DC by battery Li-Ion BA 70 or 2x AA type 1.50 V DC
		V _{max}	4.35 V
		V _{min}	2.0 V

6 Test item

6.1 General description

Test item description	:	Plug-On Transmitter
Model No.	:	EW-DP SKP
Brand name	:	SENNHEISER
Product Serie	:	Evolution Wireless Digital
HMN	:	-/-
PMN	:	EW-DP SKP
HVIN	:	EW-DP SKP
FVIN	:	1.5.0.
S/N serial number	:	Rad. Q1-6, 470 MHz – 526 MHz: 1123000128 R1-6, 520 MHz – 576 MHz: 1123000031 R4-9, 552 MHz – 607.8 MHz: 1123000034 Cond. Q1-6, 470 MHz – 526 MHz: 1123000119 R1-6, 520 MHz – 576 MHz: 1123000026 R4-9, 552 MHz – 607.8 MHz: 1123000030
Hardware status	:	589600_06
Software status	:	1.5.0
Firmware status	:	-/-
Frequency band	:	470.2 MHz to 607.8 MHz
Type of radio transmission	:	modulated carrier
Use of frequency spectrum	:	
Type of modulation	:	PI/4 DQPSK
Number of channels	:	Tuning step size: 25 kHz
Antenna	:	Internal dipole antenna
Power ratings	:	2.0 V to 4.35 V DC by battery Li-Ion BA 70 or 2x AA type 1.50 V DC
Operating temperature range	:	-10°C to +55°C

7.1 Shielded fully anechoic chamber

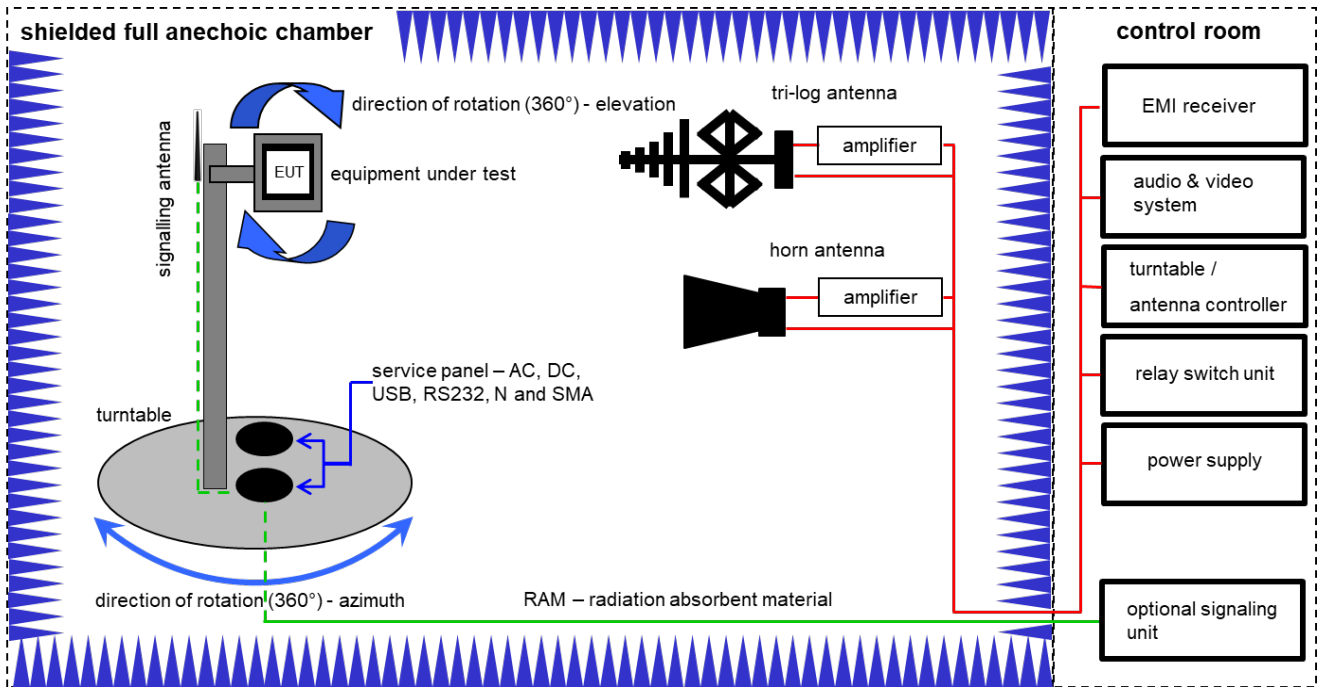

Measurement distance: tri-log antenna and horn antenna 3 meter

$$OP = AV + D - G + CA$$

(OP-radiated output power; AV-analyzer value; D-free field attenuation of measurement distance; G-antenna gain+amplifier gain; CA-loss signal path)

Example calculation:

$$OP [dBm] = -65.0 [dBm] + 50 [dB] - 20 [dBi] + 5 [dB] = -30 [dBm] (1 \mu W)$$

No.	Setup	Equipment	Type	Manufacturer	Serial No.	INV. No.	Kind of Calibration	Last Calibration	Next Calibration
1	A, B	Anechoic chamber	FAC 3/5m	MWB / TDK	87400/02	300000996	ev	-/-	-/-
2	A, B	Switch / Control Unit	3488A	HP	*	300000199	ne	-/-	-/-
3	B	Double-Ridged Waveguide Horn Antenna 1-18.0GHz	3115	EMCO	8812-3089	300000307	vKI!	11.02.2022	29.02.2024
4	A, B	EMI Test Receiver 20Hz- 26,5GHz	ESU26	R&S	100037	300003555	k	07.12.2022	31.12.2023
5	B	Highpass Filter	WHK1.1/15G-10SS	Wainwright	3	300003255	ev	-/-	-/-
6	A	TRILOG Broadband Test-Antenna 30 MHz - 3 GHz	VULB9163	Schwarzbeck Mess-Elektronik	318	300003696	vKI!	30.09.2021	29.09.2023
7	B	Broadband Amplifier 0.5-18 GHz	CBLU5184540	CERNEX	22049	300004481	ev	-/-	-/-
8	A, B	4U RF Switch Platform	L4491A	Agilent Technologies	MY50000037	300004509	ne	-/-	-/-
9	A, B	PC	ExOne	F+W		300004703	ne	-/-	-/-

7.2 Conducted measurements normal and extreme conditions

Conducted measurements normal & extreme conditions

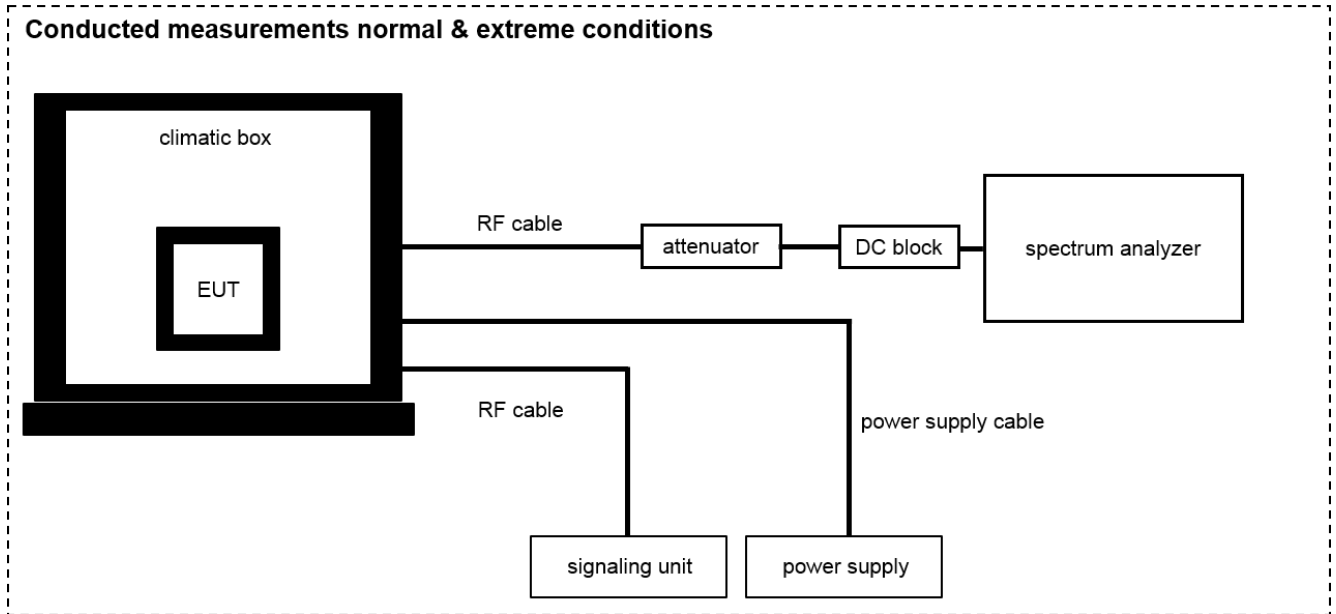

OP = AV + CA
 (OP-output power; AV-analyzer value; CA-loss signal path)

Example calculation:

OP [dBm] = 6.0 [dBm] + 11.7 [dB] = 17.7 [dBm] (58.88 mW)

Equipment table:

No.	Setup	Equipment	Type	Manufacturer	Serial No.	INV. No.	Kind of Calibration	Last Calibration	Next Calibration
1	B	Temperature Test Chamber	VT 4002	Heraeus Voetsch	521/83761	300002326	ev	12.05.2022	31.05.2024
2	A,B	Signal analyzer	FSW26	Rohde&Schwarz	101455	300004528	k	07.12.2022	31.12.2023
3	A,B	Power Supply	HMP2020	Rohde & Schwarz	102219	300006192	k	15.12.2022	31.12.2024
4	A,B	Arbitrary Function Generator	33220A	Agilent Technologies	MY44051717	300004164	vIKII	09.12.2021	31.12.2023

8 Sequence of testing

8.1 Sequence of testing radiated spurious 30 MHz to 12.75 GHz

Setup

- The equipment is set up to simulate normal operation mode as described in the user manual or defined by the manufacturer.
- If the EUT is a tabletop system, a 2-axis positioner with 1.5 m height is used.
- If the EUT is a floor standing device, it is placed directly on the turn table.
- Auxiliary equipment and cables are positioned to simulate normal operation conditions as described in ANSI C 63.4.
- The AC power port of the EUT (if available) is connected to a power outlet below the turntable.
- Measurement distance is 3 m (see ANSI C 63.4) – see test details.
- EUT is set into operation.

Premeasurement

- The turntable rotates from 0° to 315° using 45° steps.
- The antenna is polarized vertical and horizontal.
- The antenna height is 1.5 m.
- At each turntable position and antenna polarization the analyzer sweeps with positive peak detector to find the maximum of all emissions.

Final measurement

- The final measurement is performed for at least six highest peaks according to the requirements of the ANSI C63.4.
- Based on antenna and turntable positions at which the peak values are measured the software maximizes the peaks by rotating the turntable from 0° to 360°. This measurement is repeated for different EUT-table positions (0° to 150° in 30°-steps) and for both antenna polarizations.
- The final measurement is done in the position (turntable, EUT-table and antenna polarization) causing the highest emissions with Peak and RMS detector (as described in ANSI C 63.4).
- Final levels, frequency, measuring time, bandwidth, turntable position, EUT-table position, antenna polarization, correction factor, margin to the limit and limit are recorded. A plot with the graph of the premeasurement with marked maximum final results and the limit is stored.

9 Measurement uncertainty

Measurement uncertainty	
Test case	Uncertainty
Transmitter output power	± 3 dB
Occupied bandwidth	± 3 kHz to 10 kHz (depends on the used RBW)
Transmitter frequency stability	± 1 Hz to 1 kHz (depends on the used RBW)
Transmitter unwanted emissions (radiated or conducted)	Radiated: ± 3 dB Conducted: ± 0.5 dB
Modulation characteristics	-/-
Necessary bandwidth (BN) for analogue systems	± 1 kHz (depends on the used RBW)
Frequency modulation	± 3 kHz (depends on the used RBW)
Spurious emissions conducted below 30 MHz (AC conducted)	± 2.6 dB

10 Summary of measurement results

<input checked="" type="checkbox"/>	No deviations from the technical specifications were ascertained
<input type="checkbox"/>	There were deviations from the technical specifications ascertained
<input type="checkbox"/>	This test report is only a partial test report. The content and verdict of the performed test cases are listed below.

TC Identifier	Description	Verdict	Date	Remark
RF-Testing	FCC Part 74 RSS - 210, Issue 9 RSS-Gen Issue 4	See table!	2023-04-28	-/-

Test specification clause	Test case	Temperature conditions	Voltage conditions	C	NC	NA	NP	Remark
FCC Part 74.861 (e)(1)(ii) FCC Part 2.1046 RSS-210 – G.3.1 RSS-Gen – 6.12	Transmitter output power	Nominal	Nominal	<input checked="" type="checkbox"/>	<input type="checkbox"/>	<input type="checkbox"/>	<input type="checkbox"/>	-/-
FCC Part 74.861 (e)(5) FCC Part 2.1049 RSS-210 – G.3.2 RSS-Gen – 6.6	Occupied bandwidth	Nominal	Nominal	<input checked="" type="checkbox"/>	<input type="checkbox"/>	<input type="checkbox"/>	<input type="checkbox"/>	-/-
FCC Part 74.861 (e)(4) FCC Part 2.1055 RSS-210 – G.3.3 RSS-Gen – 6.11	Transmitter frequency stability	Nominal	Nominal	<input checked="" type="checkbox"/>	<input type="checkbox"/>	<input type="checkbox"/>	<input type="checkbox"/>	-/-
		Extreme	Extreme	<input checked="" type="checkbox"/>	<input type="checkbox"/>	<input type="checkbox"/>	<input type="checkbox"/>	
FCC Part 74.861 (e)(6) FCC Part 74.861 (e)(7) RSS-210 – G.3.4 ETSI EN 300 422-1 v1.4.2 (2011-08)	Transmitter unwanted emissions (radiated or conducted)	Nominal	Nominal	<input checked="" type="checkbox"/>	<input type="checkbox"/>	<input type="checkbox"/>	<input type="checkbox"/>	-/-
FCC Part 2.1047	Modulation characteristics	Nominal	Nominal	-/-				Digital modulation
FCC Part 74.861 (e)(7) ETSI EN 300 422-1 v1.4.2 (2011-08)	Necessary bandwidth (BN) for analogue systems	Nominal	Nominal	<input checked="" type="checkbox"/>	<input type="checkbox"/>	<input type="checkbox"/>	<input type="checkbox"/>	-/-
FCC Part 74.861 (e)(3) RSS-210 – G.3.5.2	Frequency modulation	Nominal	Nominal	<input type="checkbox"/>	<input type="checkbox"/>	<input checked="" type="checkbox"/>	<input type="checkbox"/>	Digital modulation
FCC Part 74.861 (e)(7) RSS-210 – G.3.4	Receiver spurious emissions	Nominal	Nominal	<input type="checkbox"/>	<input type="checkbox"/>	<input checked="" type="checkbox"/>	<input type="checkbox"/>	No receiver integrated!
FCC Part 15.107(a) FCC Part 15.207	Conducted emissions < 30 MHz	Nominal	Nominal	<input type="checkbox"/>	<input type="checkbox"/>	<input checked="" type="checkbox"/>	<input type="checkbox"/>	-/-

Note: C = Compliant; NC = Not compliant; NA = Not applicable; NP = Not performed

11 Additional comments

Reference documents: None

Special test descriptions: None

Configuration descriptions: None

Test mode: No test mode available.
Test signal is applied to the transmitter.

Special software is used.
EUT is transmitting pseudo random data by itself

Antennas and transmit operating modes: **Operating mode 1 (single antenna)**

- *Equipment with 1 antenna,*
- *Equipment with 2 diversity antennas operating in switched diversity mode by which at any moment in time only 1 antenna is used,*
- *Smart antenna system with 2 or more transmit/receive chains, but operating in a mode where only 1 transmit/receive chain is used)*

Operating mode 2 (multiple antennas, no beamforming)

- *Equipment operating in this mode contains a smart antenna system using two or more transmit/receive chains simultaneously but without beamforming.*

Operating mode 3 (multiple antennas, with beamforming)

- *Equipment operating in this mode contains a smart antenna system using two or more transmit/receive chains simultaneously with beamforming. In addition to the antenna assembly gain (G), the beamforming gain (Y) may have to be taken into account when performing the measurements.*

12 Measurement results

12.1 Transmitter output power

Measurement:

Measurement parameter	
Detector:	Peak (worst case) / Average (RMS)
Sweep time:	Auto / 20s
Resolution bandwidth:	> emission bandwidth
Video bandwidth:	> resolution bandwidth
Span:	> 2 times emissions bandwidth
Trace mode:	Max. hold
EUT configuration:	Peak: Unmodulated carrier RMS: Modulate the transmitter with a 2.5 kHz tone at a level 16 dB higher than that required to produce a frequency deviation of ± 75 kHz, or to produce 50% of the manufacturer's rated deviation, whichever is less.
Test setup:	See sub clause 7.2 – A
Measurement uncertainty:	See sub clause 9

Limits:

FCC (conducted)	
470 MHz to 608 MHz	250 mW (average) / 24 dBm (average)
IC (e.i.r.p.)	
470 MHz to 608 MHz	250 mW (average) / 24 dBm (average)

Result:

Transmitter output power conducted / dBm						
Channels	Q1-6			R1-6		
Frequencies / MHz	470.2	498.0	526.0	520.0	548.0	576.0
Peak	13.58	13.76	13.98	13.04	13.34	13.51
Average	9.67	10.01	10.26	9.18	9.56	9.73
Channels	R4-9					
Frequencies / MHz	552.0		580.0		607.8	
Peak	12.56		12.63		12.2	
Average	8.77		8.81		8.69	

Transmitter output power e.i.r.p. / dBm						
Channels	Q1-6			R1-6		
Frequencies / MHz	470.2	498.0	526.0	520.0	548.0	576.0
Peak	10.42	10.60	9.46	8.83	9.27	11.13
Average	6.51	6.85	5.74	4.97	5.49	7.35
Channels	R4-9					
Frequencies / MHz	552.0		580.0		607.8	
Peak	9.80		11.87		12.46	
Average	6.01		8.05		8.95	

Plots output power conducted, normal mode:

Plot 1: Q1-6, 470.200 MHz

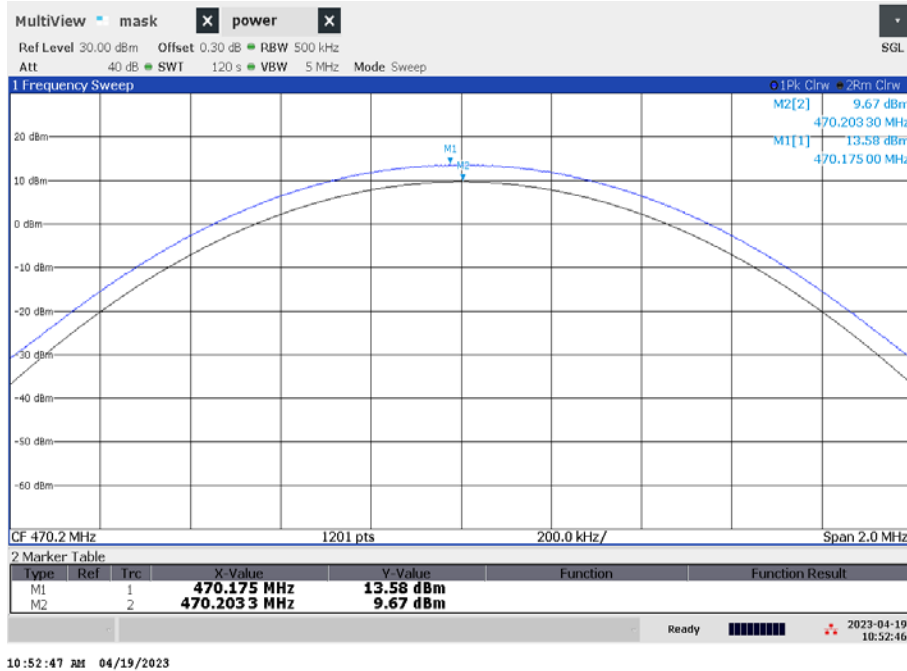

Plot 2: Q1-6, 498.000 MHz

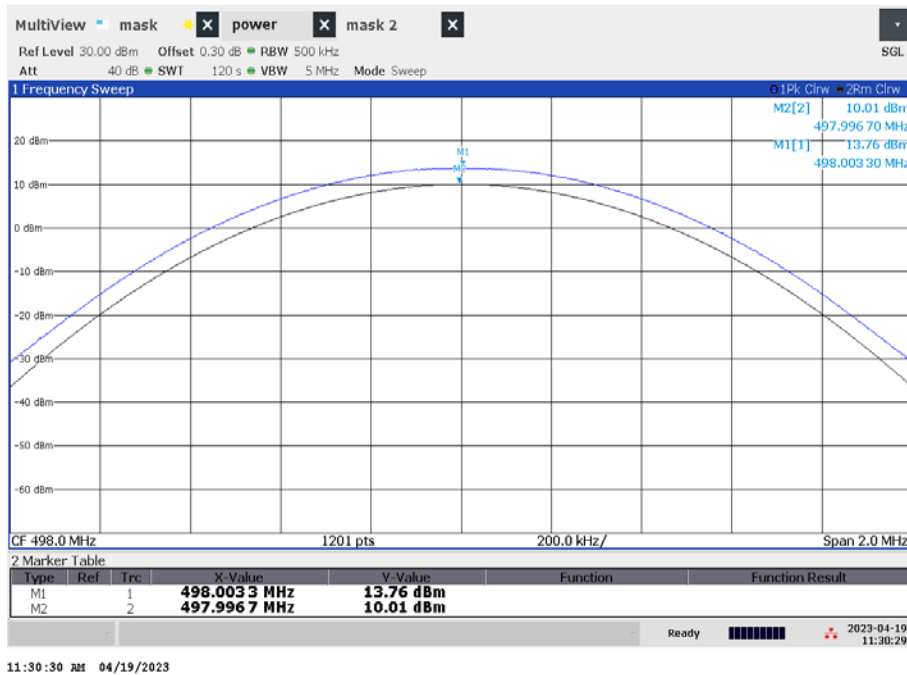

Plot 3: Q1-6, 526.0 MHz

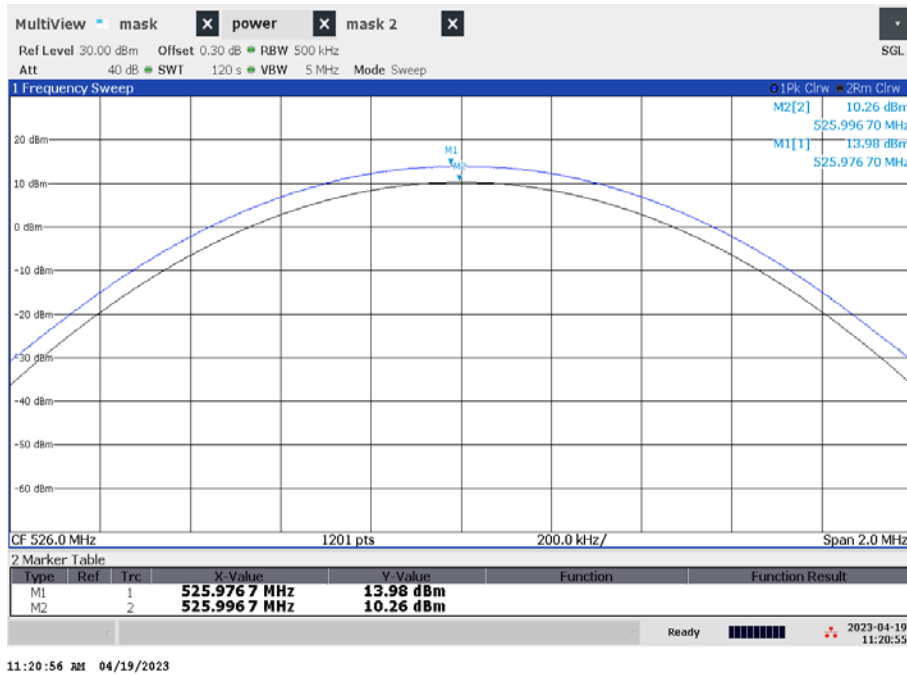

Plot 4: R1-6, 520.000 MHz

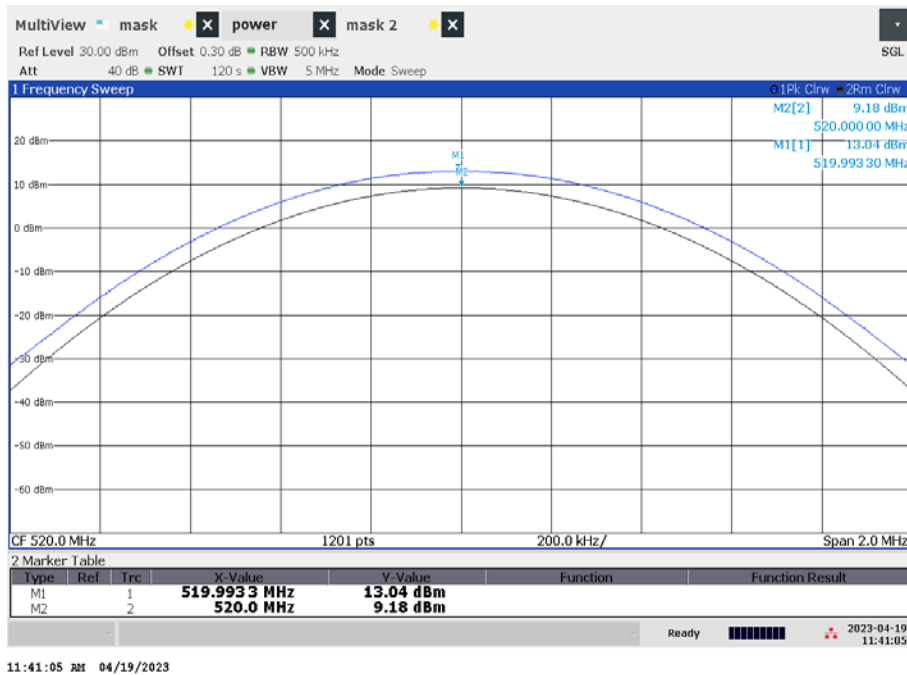

Plot 5: R1-6, 548.000 MHz

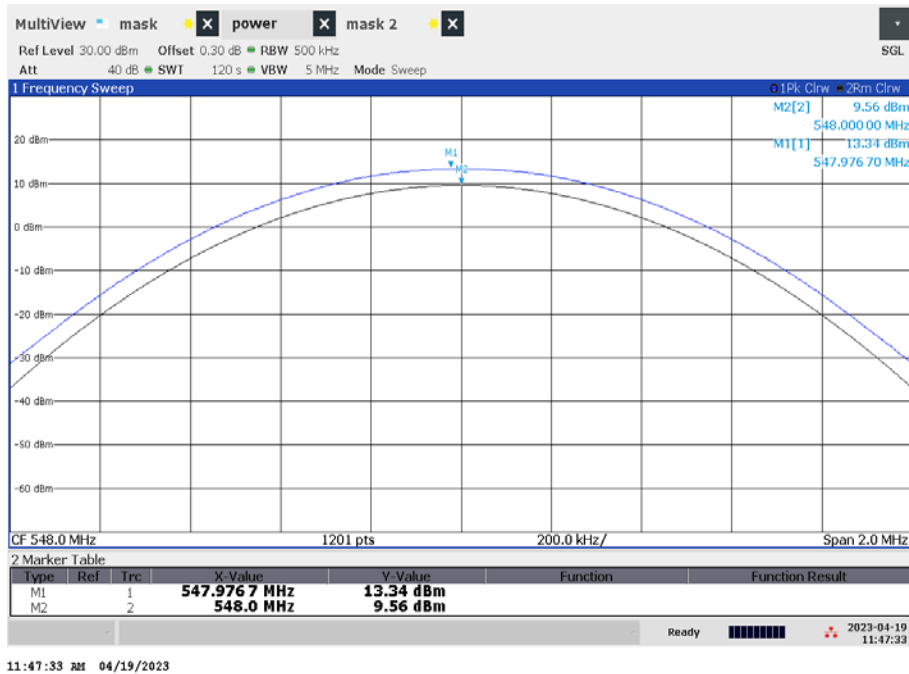

Plot 6: R1-6, 576.000 MHz

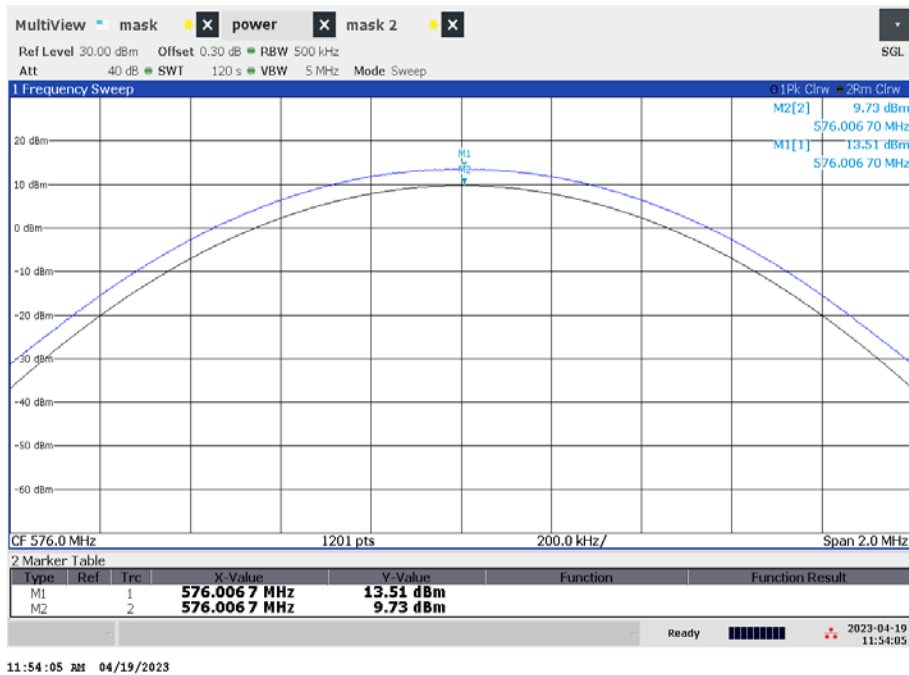

Plot 7: R4-9, 552.000 MHz

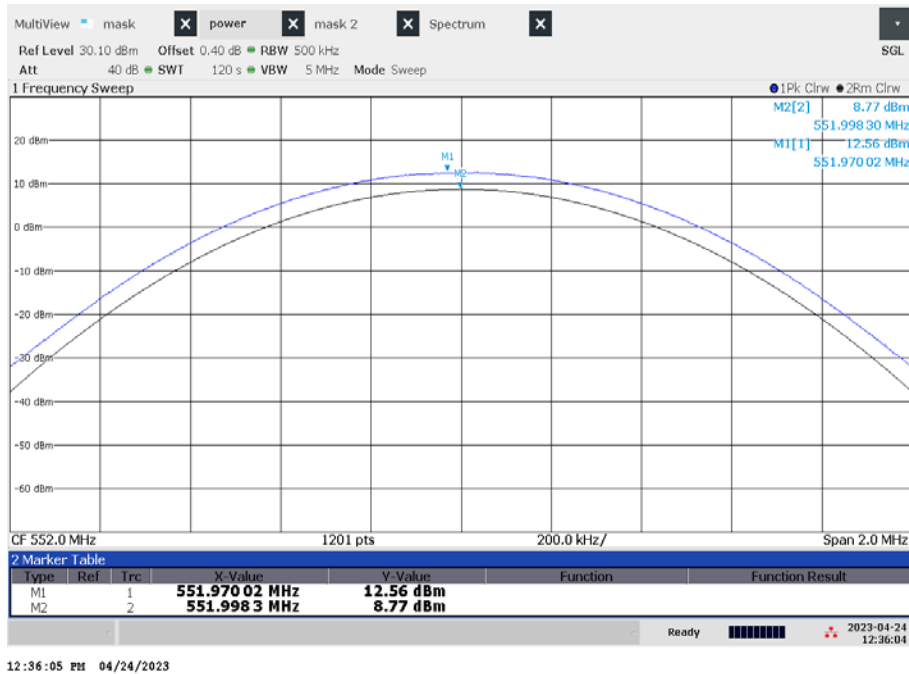

Plot 8: R4-9, 580.000 MHz

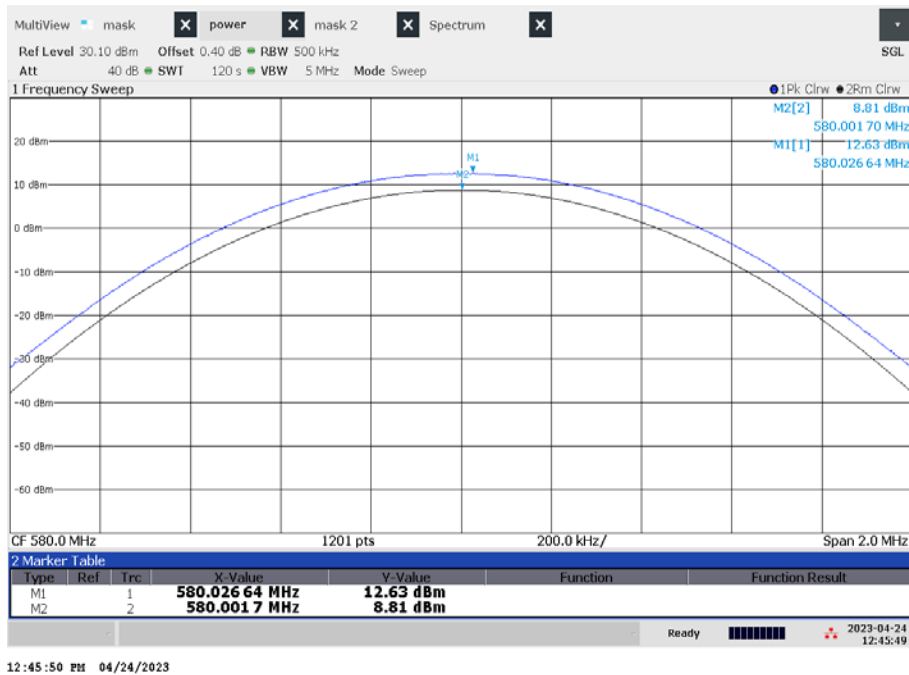

Plot 9: R4-9, 607.800 MHz

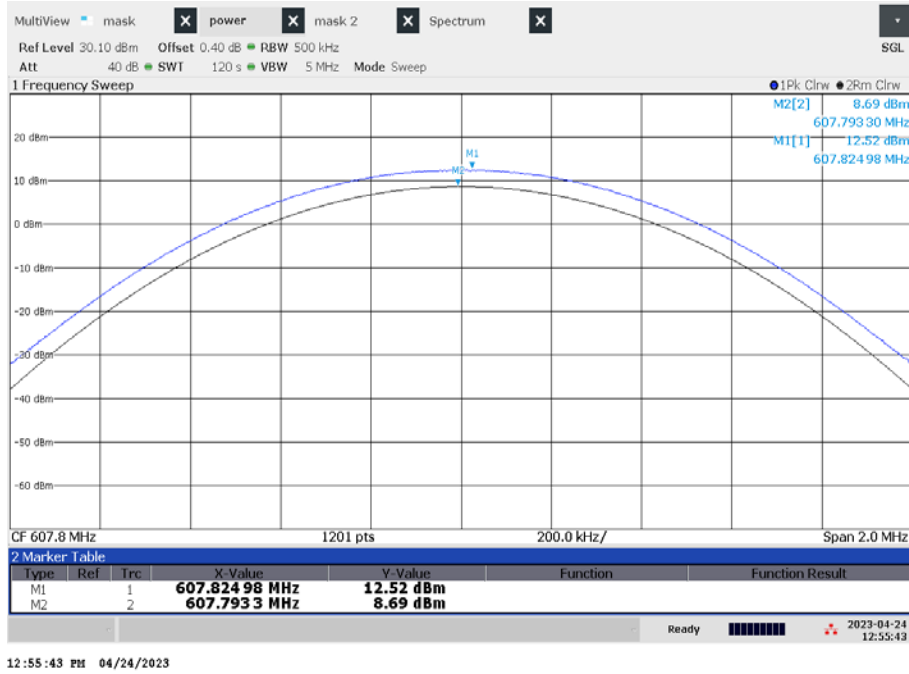

12.2 Occupied bandwidth

Measurement:

Measurement parameter	
Detector:	Peak
Sweep time:	Auto
Resolution bandwidth:	1 % to 5 % of the occupied bandwidth
Video bandwidth:	3 x resolution bandwidth
Span:	2 x emission bandwidth
Trace mode:	Max. hold
Analyzer function:	99% power occupied bandwidth function
EUT:	Modulated signal with max. frequency deviation
Test setup:	See sub clause 7.2 - A
Measurement uncertainty:	See sub clause 9

Limits:

FCC & IC
470 MHz to 608 MHz 200 kHz
Occupied bandwidth 99%. Other than single sideband or independent sideband transmitters - when modulated by a 2500 Hz tone at an input level 16 dB greater than that necessary to produce 50 percent modulation. The input level shall be established at the frequency of maximum response of the audio modulating circuit.

Result:

Centre frequency (fc)	OBW
470.200 MHz	170.29 kHz
498.000 MHz	171.32 kHz
526.000 MHz	170.21 kHz
520.000 MHz	170.57 kHz
548.000 MHz	169.78 kHz
576.000 MHz	172.29 kHz
552.000 MHz	171.63 kHz
580.000 MHz	169.56 kHz
607.800 MHz	171.36 kHz

Plots:

Plot 1: Q1-6, 470.200 MHz

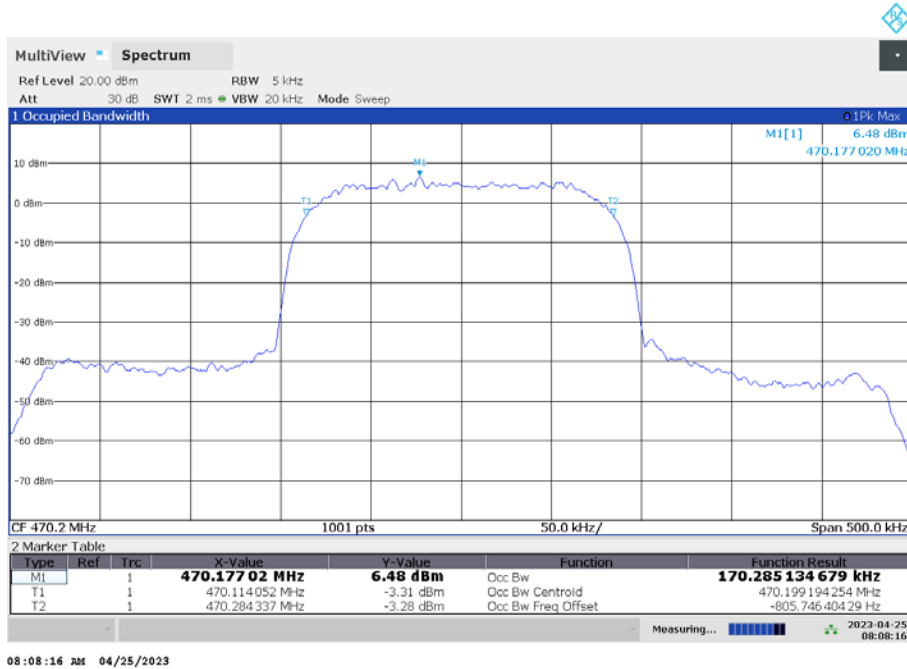

Plot 2: Q1-6, 498.000 MHz

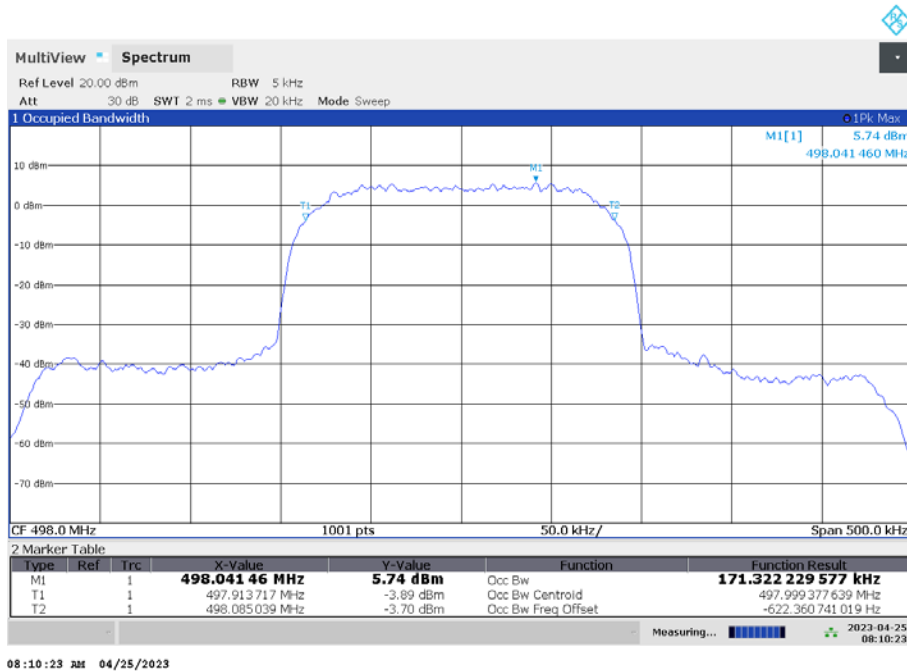

Plot 3: Q1-6, 526.0 MHz

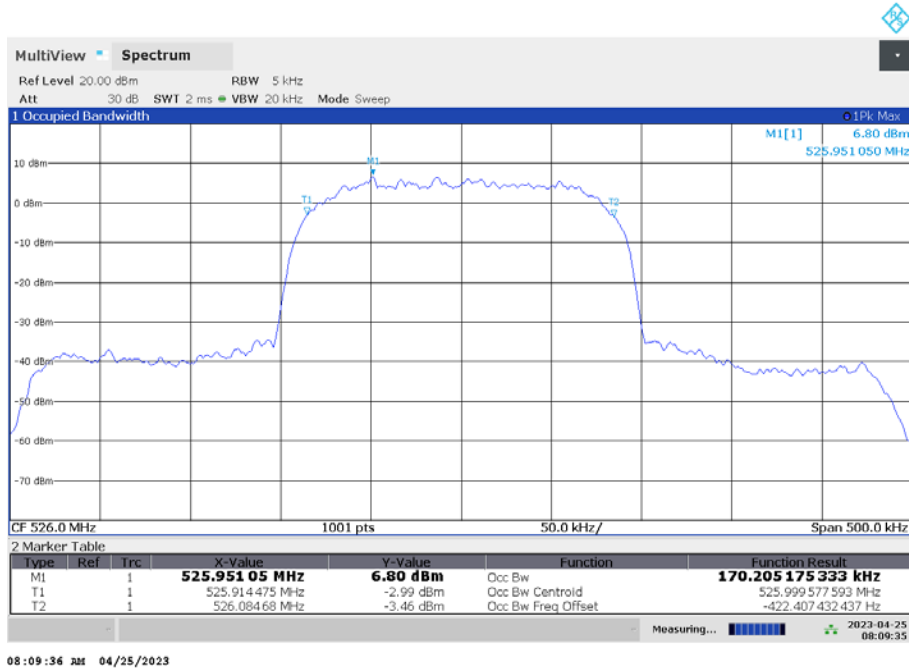

Plot 4: R1-6, 520.000 MHz

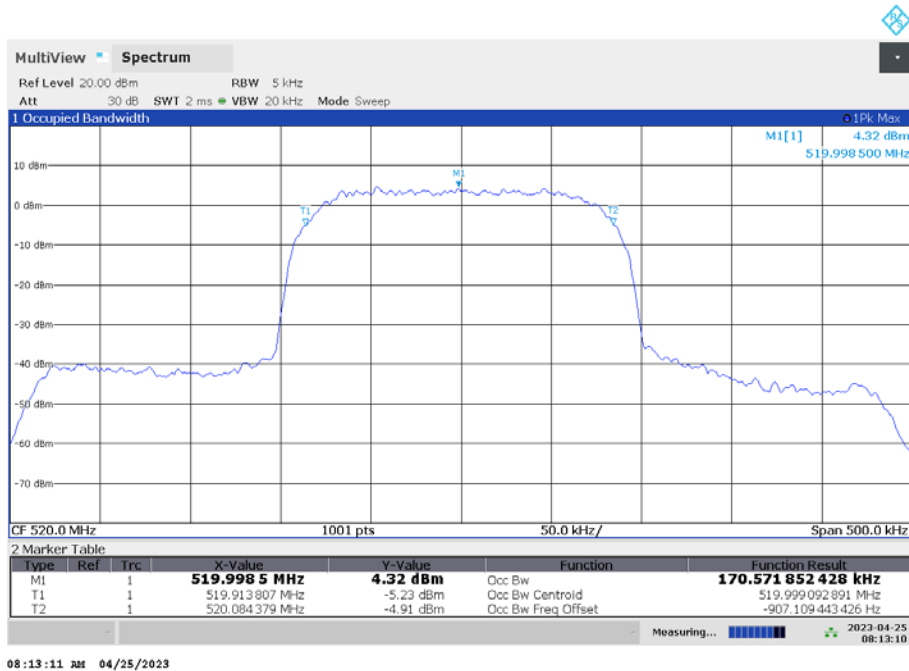

Plot 5: R1-6, 548.000 MHz

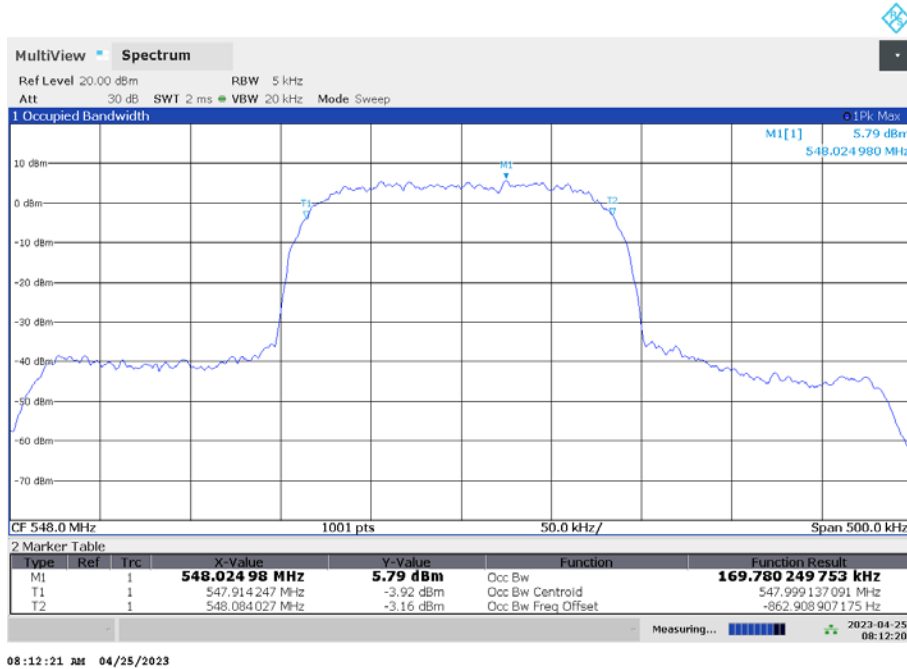

Plot 6: R1-6, 576.000 MHz

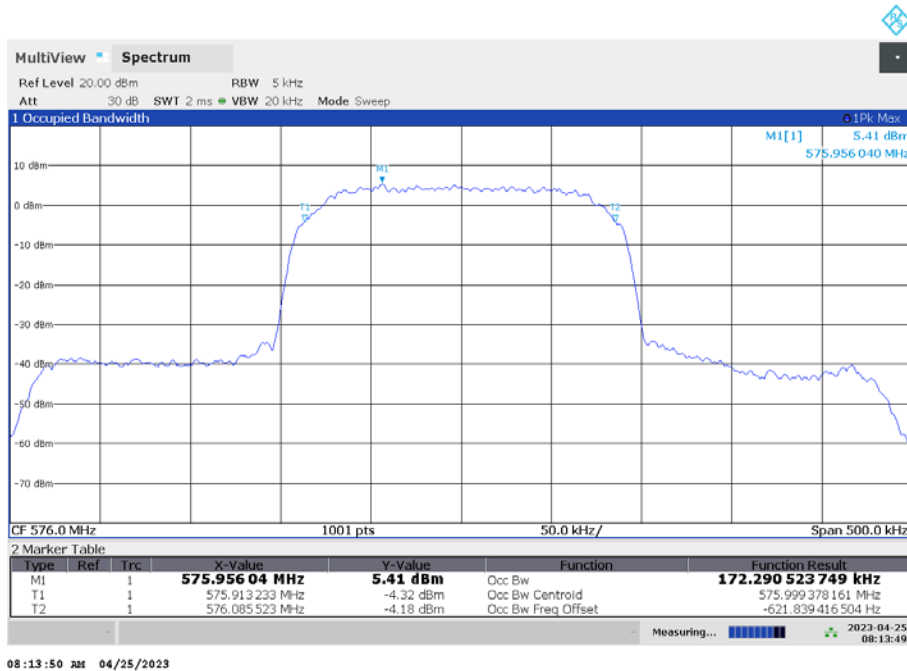

Plot 7: R4-9, 552.000 MHz

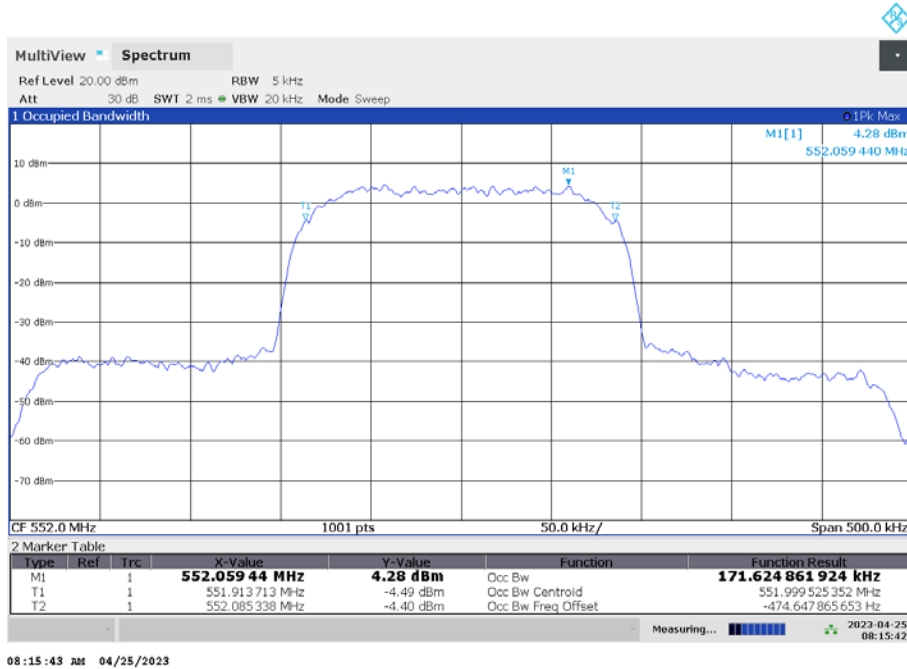

Plot 8: R4-9, 580.000 MHz

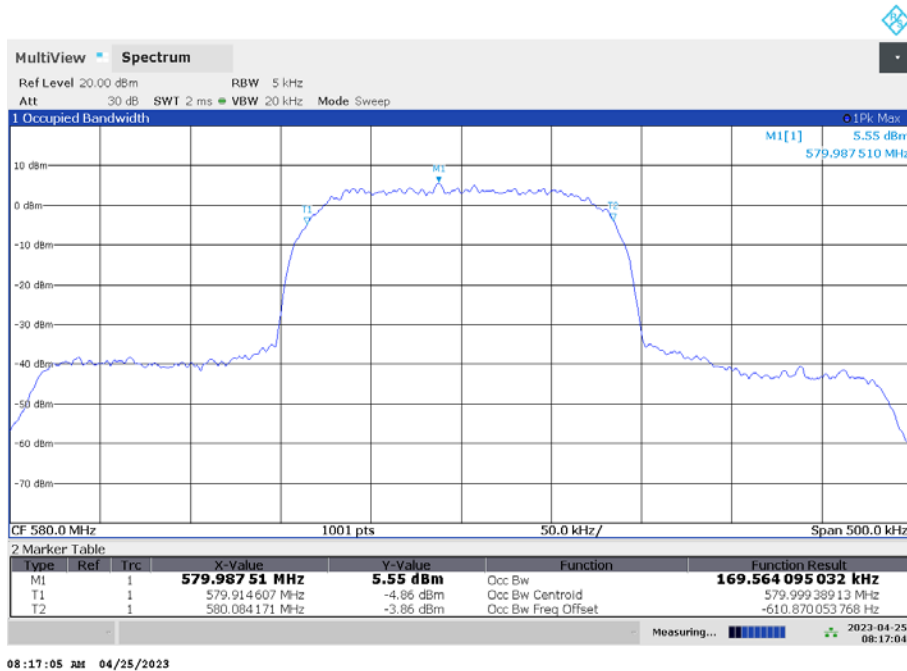

Plot 9: R4-9, 607.800 MHz

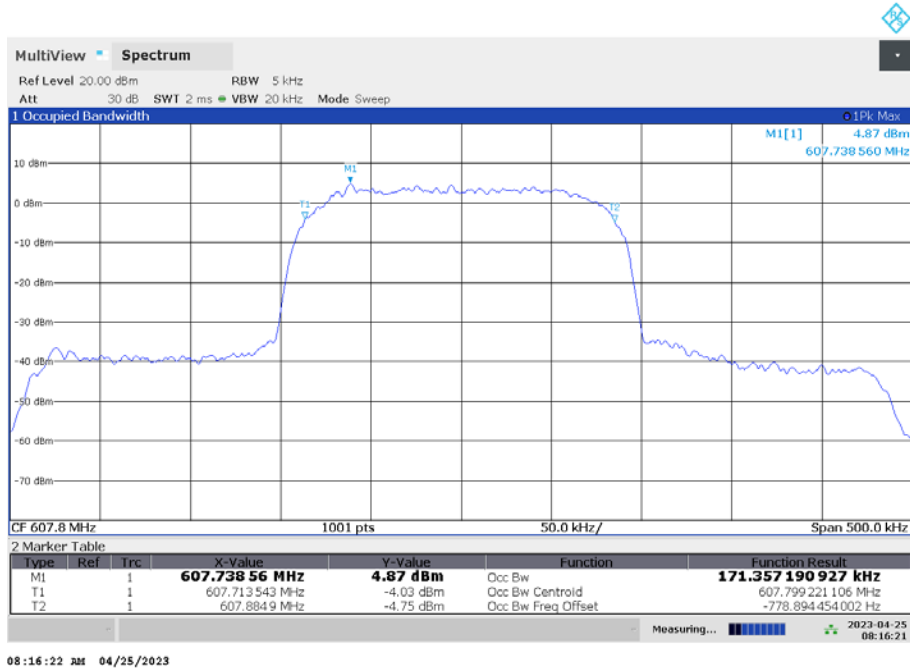

12.3 Transmitter frequency stability

Measurement:

Measurement parameter	
Detector:	Peak
Sweep time:	Auto
Resolution bandwidth:	20 Hz
Video bandwidth:	3 x resolution bandwidth
Span:	wide enough to follow the frequency drift
Trace mode:	clear/write/view
EUT:	CW signal or MC with measurement method description
Test setup:	See sub clause 7.2A/ B
Measurement uncertainty:	See sub clause 9

Limits:

FCC & IC
470 MHz to 608 MHz \pm 50 ppm

Results: 470.200 MHz

Temperature / Voltage	Frequency (MHz)	Deviation (kHz / ppm)
-30 °C / V_{nom}	470.199482	-0.518 / 1.10
-20 °C / V_{nom}	470.199939	-0.061 / 0.13
-10 °C / V_{nom}	470.200092	0.092 / 0.20
0 °C / V_{nom}	470.200197	0.197 / 0.42
+10 °C / V_{nom}	470.199705	-0.295 / 0.63
+20 °C / V_{nom}	470.200421	0.421 / 0.90
+30 °C / V_{nom}	470.200078	0.078 / 0.17
+40 °C / V_{nom}	470.199898	-0.102 / 0.22
+50 °C / V_{nom}	470.199723	-0.277 / 0.59
<hr/>		
+20 °C / $V_{nom} - 15\%$	470.200202	0.202 / 0.43
+20 °C / V_{nom}	470.200421	0.421 / 0.90
+20 °C / $V_{nom} + 15\%$	470.200066	0.066 / 0.14

Results: 498.000 MHz

Temperature / Voltage	Frequency (MHz)	Deviation (kHz / ppm)
-30 °C / V _{nom}	497.999621	-0.379 / 0.76
-20 °C / V _{nom}	497.999883	-0.117 / 0.24
-10 °C / V _{nom}	497.999373	-0.627 / 1.26
0 °C / V _{nom}	497.999767	-0.233 / 0.47
+10 °C / V _{nom}	498.000025	0.025 / 0.05
+20 °C / V _{nom}	498.000043	0.043 / 0.09
+30 °C / V _{nom}	497.999493	-0.507 / 1.02
+40 °C / V _{nom}	498.000115	0.115 / 0.23
+50 °C / V _{nom}	497.999828	-0.172 / 0.35
+20 °C / V _{nom} - 15%	498.000111	0.111 / 0.22
+20 °C / V _{nom}	498.000043	0.043 / 0.09
+20 °C / V _{nom} + 15%	498.000636	0.636 / 1.28

Results: 526.000 MHz

Temperature / Voltage	Frequency (MHz)	Deviation (kHz / ppm)
-30 °C / V _{nom}	525.999750	-0.250 / 0.48
-20 °C / V _{nom}	525.999500	-0.500 / 0.95
-10 °C / V _{nom}	526.000250	0.250 / 0.47
0 °C / V _{nom}	526.000500	0.500 / 0.95
+10 °C / V _{nom}	526.000000	0.000 / 0.00
+20 °C / V _{nom}	525.999750	-0.250 / 0.48
+30 °C / V _{nom}	526.000000	0.000 / 0.00
+40 °C / V _{nom}	526.000000	0.000 / 0.00
+50 °C / V _{nom}	526.000250	0.250 / 0.47
+20 °C / V _{nom} - 15%	525.999417	-0.583 / 1.11
+20 °C / V _{nom}	525.999750	-0.250 / 0.48
+20 °C / V _{nom} + 15%	525.999917	-0.083 / 0.16

Results: 520.000 MHz

Temperature / Voltage	Frequency (MHz)	Deviation (kHz / ppm)
-30 °C / V _{nom}	519.999251	-0.749 / 1.44
-20 °C / V _{nom}	519.999750	-0.250 / 0.48
-10 °C / V _{nom}	519.999750	-0.250 / 0.48
0 °C / V _{nom}	520.000000	0.000 / 0.00
+10 °C / V _{nom}	519.999750	-0.250 / 0.48
+20 °C / V _{nom}	520.000083	0.083 / 0.16
+30 °C / V _{nom}	519.999750	-0.250 / 0.48
+40 °C / V _{nom}	520.000000	0.000 / 0.00
+50 °C / V _{nom}	520.000250	0.250 / 0.48
+20 °C / V _{nom} - 15%	520.000167	0.167 / 0.32
+20 °C / V _{nom}	520.000083	0.083 / 0.16
+20 °C / V _{nom} + 15%	520.000167	0.167 / 0.32

Results: 548.000 MHz

Temperature / Voltage	Frequency (MHz)	Deviation (kHz / ppm)
-30 °C / V _{nom}	547.999908	-0.092 / 0.17
-20 °C / V _{nom}	547.999488	-0.512 / 0.93
-10 °C / V _{nom}	548.000141	0.141 / 0.26
0 °C / V _{nom}	547.999938	-0.062 / 0.11
+10 °C / V _{nom}	548.000518	0.518 / 0.95
+20 °C / V _{nom}	548.000316	0.316 / 0.58
+30 °C / V _{nom}	548.000142	0.142 / 0.26
+40 °C / V _{nom}	547.999807	-0.193 / 0.35
+50 °C / V _{nom}	547.999831	-0.169 / 0.31
+20 °C / V _{nom} - 15%	547.999979	-0.021 / 0.04
+20 °C / V _{nom}	548.000316	0.316 / 0.58
+20 °C / V _{nom} + 15%	547.999796	-0.204 / 0.37

Results: 576.0 MHz

Temperature / Voltage	Frequency (MHz)	Deviation (kHz / ppm)
-30 °C / V _{nom}	575.999251	-0.749 / 1.30
-20 °C / V _{nom}	575.999750	-0.250 / 0.43
-10 °C / V _{nom}	575.999750	-0.250 / 0.43
0 °C / V _{nom}	575.999500	-0.500 / 0.87
+10 °C / V _{nom}	576.000000	0.000 / 0.00
+20 °C / V _{nom}	576.000000	0.000 / 0.00
+30 °C / V _{nom}	575.999750	-0.250 / 0.43
+40 °C / V _{nom}	575.999750	-0.250 / 0.43
+50 °C / V _{nom}	576.000000	0.000 / 0.00
+20 °C / V _{nom} - 15%	575.999975	-0.250 / 0.43
+20 °C / V _{nom}	575.999667	-0.333 / 0.58
+20 °C / V _{nom} + 15%	575.999750	-0.250 / 0.43

Results: 552.0 MHz

Temperature / Voltage	Frequency (MHz)	Deviation (kHz / ppm)
-30 °C / V _{nom}	551.999251	-0.749 / 1.36
-20 °C / V _{nom}	551.999500	-0.500 / 0.90
-10 °C / V _{nom}	551.999750	-0.250 / 0.45
0 °C / V _{nom}	551.999750	-0.250 / 0.45
+10 °C / V _{nom}	551.999500	-0.500 / 0.90
+20 °C / V _{nom}	551.999500	-0.500 / 0.90
+30 °C / V _{nom}	551.999500	-0.500 / 0.90
+40 °C / V _{nom}	551.999500	-0.500 / 0.90
+50 °C / V _{nom}	552.000000	0.000 / 0.00
+20 °C / V _{nom} - 15%	551.999667	-0.333 / 0.60
+20 °C / V _{nom}	551.999833	-0.167 / 0.30
+20 °C / V _{nom} + 15%	551.999833	-0.167 / 0.30

Results: 580.0 MHz

Temperature / Voltage	Frequency (MHz)	Deviation (kHz / ppm)
-30 °C / V _{nom}	579.999500	-0.500 / 0.86
-20 °C / V _{nom}	579.999251	-0.749 / 1.29
-10 °C / V _{nom}	579.999500	-0.500 / 0.86
0 °C / V _{nom}	579.999500	-0.500 / 0.86
+10 °C / V _{nom}	579.999500	-0.500 / 0.86
+20 °C / V _{nom}	579.999750	-0.250 / 0.43
+30 °C / V _{nom}	579.999251	-0.749 / 1.29
+40 °C / V _{nom}	579.999500	-0.500 / 0.86
+50 °C / V _{nom}	579.999750	-0.250 / 0.43
+20 °C / V _{nom} - 15%	579.999667	-0.333 / 0.57
+20 °C / V _{nom}	579.999750	-0.250 / 0.43
+20 °C / V _{nom} + 15%	579.999667	-0.333 / 0.57

Results: 607.8 MHz

Temperature / Voltage	Frequency (MHz)	Deviation (kHz / ppm)
-30 °C / V _{nom}	607.799251	-0.749 / 1.23
-20 °C / V _{nom}	607.799500	-0.500 / 0.82
-10 °C / V _{nom}	607.799750	-0.250 / 0.41
0 °C / V _{nom}	607.800000	0.000 / 0.00
+10 °C / V _{nom}	607.799750	-0.250 / 0.41
+20 °C / V _{nom}	607.799750	-0.250 / 0.41
+30 °C / V _{nom}	607.799750	-0.250 / 0.41
+40 °C / V _{nom}	607.799750	-0.250 / 0.41
+50 °C / V _{nom}	607.799750	-0.250 / 0.41
+20 °C / V _{nom} - 15%	607.799417	-0.583 / 0.96
+20 °C / V _{nom}	607.799750	-0.250 / 0.41
+20 °C / V _{nom} + 15%	607.799750	-0.250 / 0.41

12.4 Transmitter unwanted emissions (radiated)

Measurement:

Measurement parameter							
Detector:	Peak (prescan) / RMS						
Sweep time:	Auto						
Resolution bandwidth:	<table border="0"> <tr> <td>25 MHz to 30 MHz</td> <td>9 kHz to 10 kHz</td> </tr> <tr> <td>30 MHz to 1 000 MHz</td> <td>100 kHz</td> </tr> <tr> <td>> 1 000 MHz</td> <td>1 MHz</td> </tr> </table>	25 MHz to 30 MHz	9 kHz to 10 kHz	30 MHz to 1 000 MHz	100 kHz	> 1 000 MHz	1 MHz
25 MHz to 30 MHz	9 kHz to 10 kHz						
30 MHz to 1 000 MHz	100 kHz						
> 1 000 MHz	1 MHz						
Video bandwidth:	3 * RBW						
Span:	100 MHz steps!						
Trace-Mode:	Max. hold						
EUT:	MC with max frequency deviation						
Used equipment:	See chapter 7.1- A / B						
Measurement uncertainty:	See chapter 9						

Limits:

Max. spurious level FCC & IC (according to ETSI EN 300 422-1 v1.4.2 (2011-08))			
State	47 MHz to 74 MHz 87.5 MHz to 118 MHz 174 MHz to 230 MHz 470 MHz to 862 MHz	Other frequencies ≤ 1000 MHz	All frequencies > 1000 MHz
Operating	4.0 nW	250 nW	1.00 µW
Standby	2.0 nW	2.0 nW	20.0 nW
FCC & IC			
The mean power of emissions shall be attenuated below the mean output power of the transmitter in accordance with the following schedule:			
On any frequency removed from the operating frequency by more than 50 percent up to and including 100 percent of the authorized bandwidth: at least			25 dB
On any frequency removed from the operating frequency by more than 100 percent up to and including 250 percent of the authorized bandwidth			35 dB
On any frequency removed from the operating frequency by more than 250 percent of the authorized bandwidth: at least			43 + 10log ₁₀ (mean output power in watts) dB

Results:

carrier frequency (MHz)	unwanted emission frequency (MHz)	Limit	level (dB) / (dBm) or remark
470.200 MHz	all detected emissions are more than 10 dB below the limit.		
498.000 MHz			
526.000 MHz			
520.000 MHz	all detected emissions are more than 10 dB below the limit.		
548.000 MHz	1096	-30	-52.17
576.000 MHz	all detected emissions are more than 10 dB below the limit.		
552.000 MHz	all detected emissions are more than 10 dB below the limit.		
580.000 MHz			
607.800 MHz			

Plots: radiated

Plot 1: Q1-6, 470.200 MHz, 25 MHz – 12.75 GHz

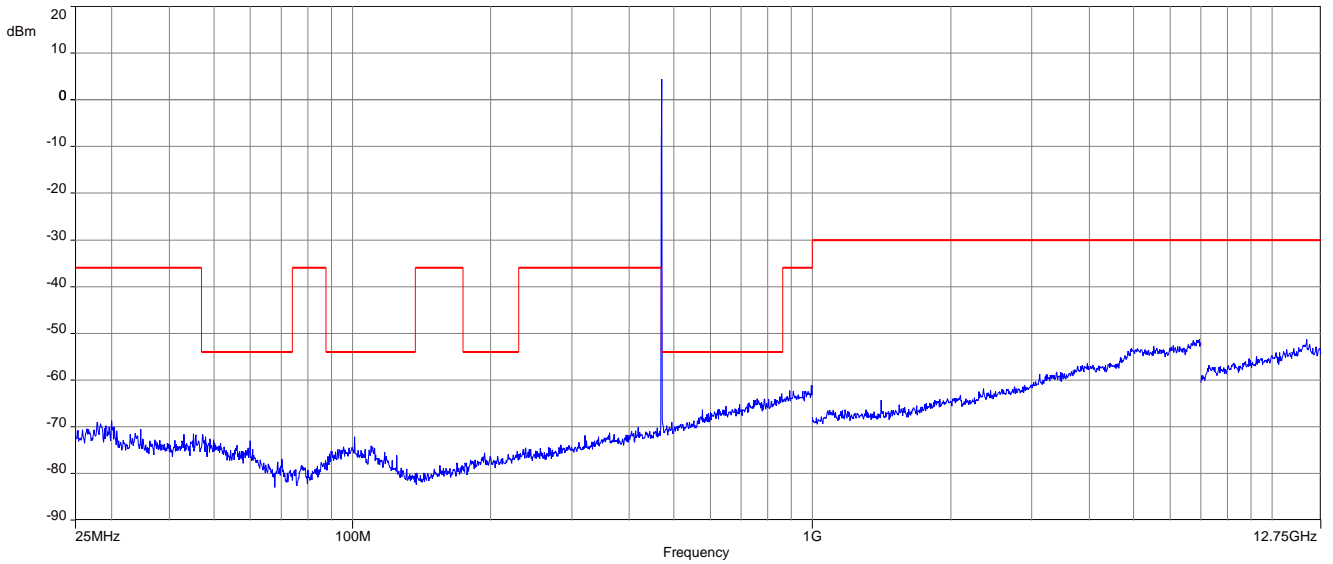

Plot 2: Q1-6, 498.000 MHz, 25 MHz – 12.75 GHz

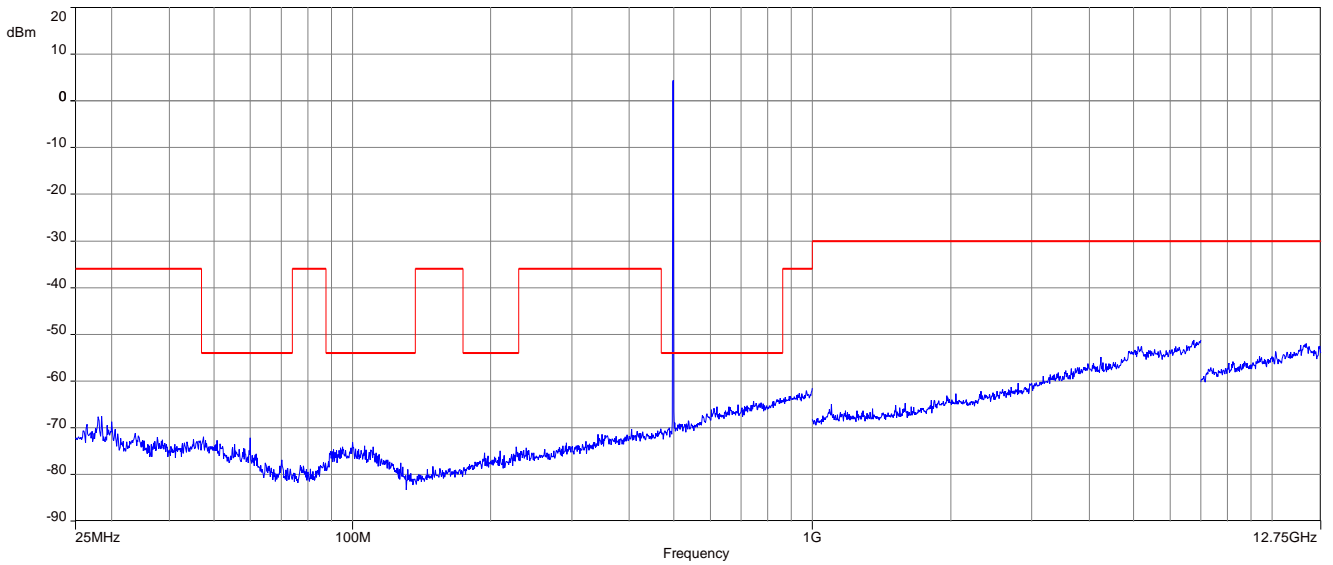

Plot 3: Q1-6, 526.000 MHz, 25 MHz – 12.75 GHz

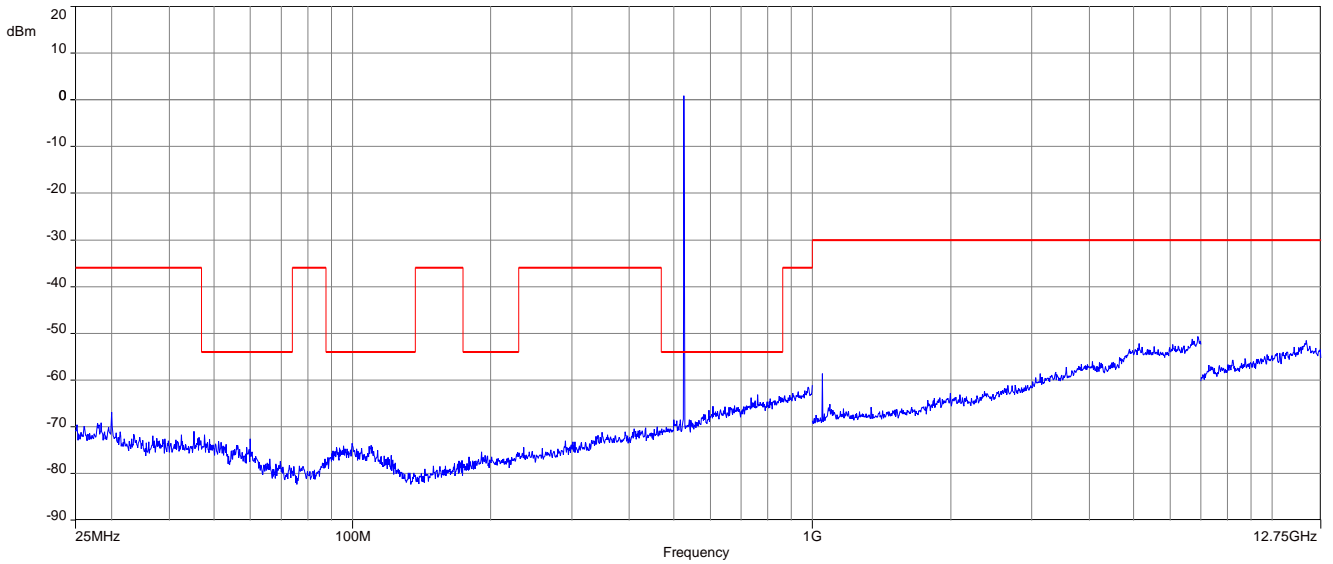

Plot 4: R1-6, 520.000 MHz, 25 MHz – 12.75 GHz

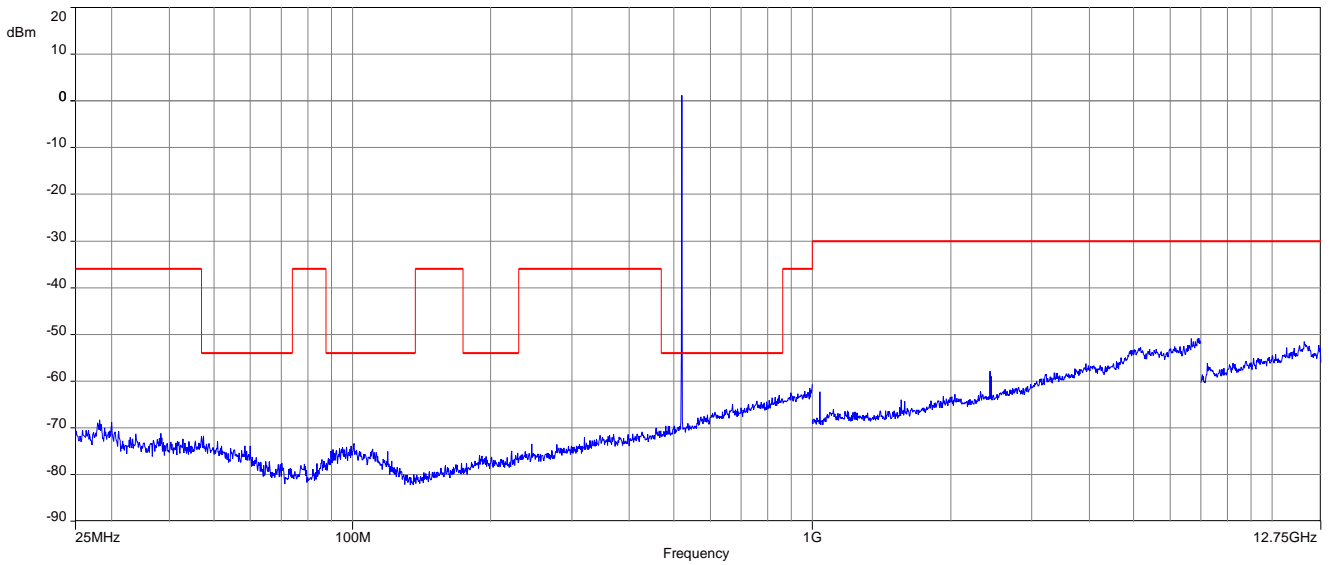

Plot 5: R1-6, 548.000 MHz, 25 MHz – 12.75 GHz

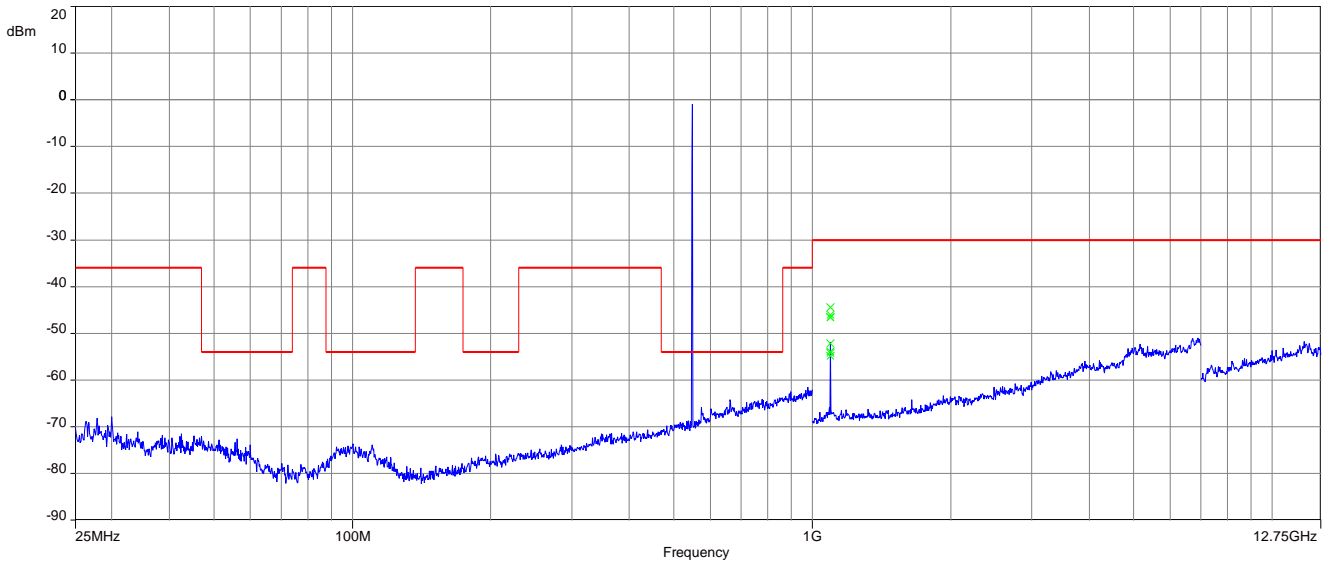

Plot 6: R1-6, 576.000 MHz, 25 MHz – 12.75 GHz

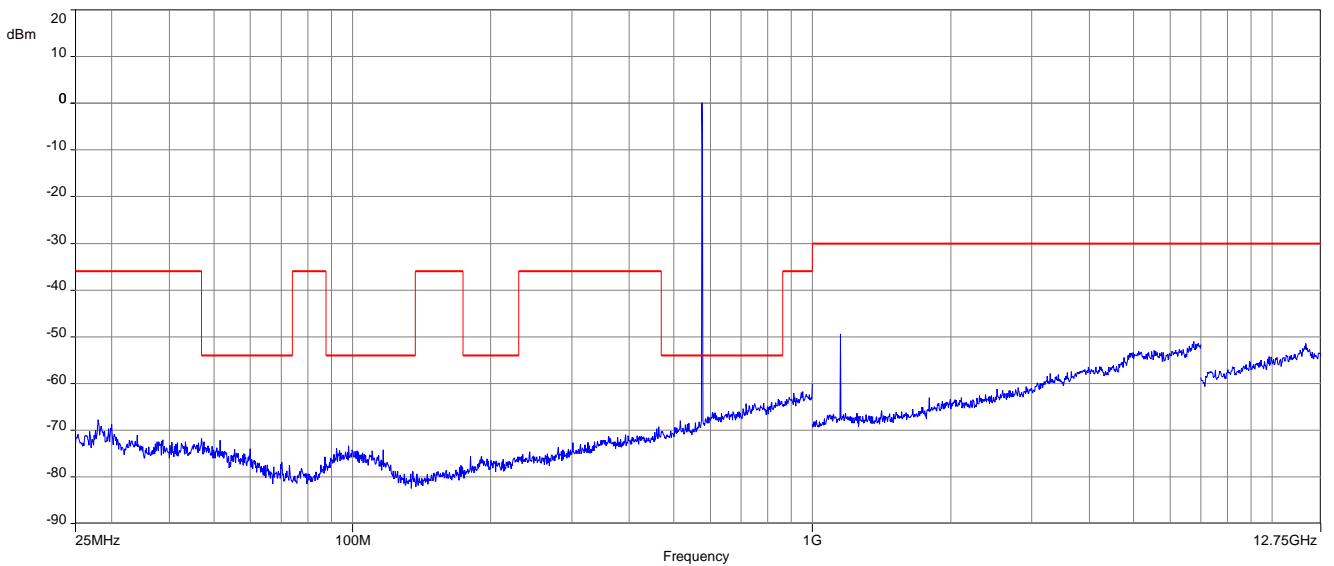

Plot 7: R4-9, 552.000 MHz, 25 MHz – 12.75 GHz

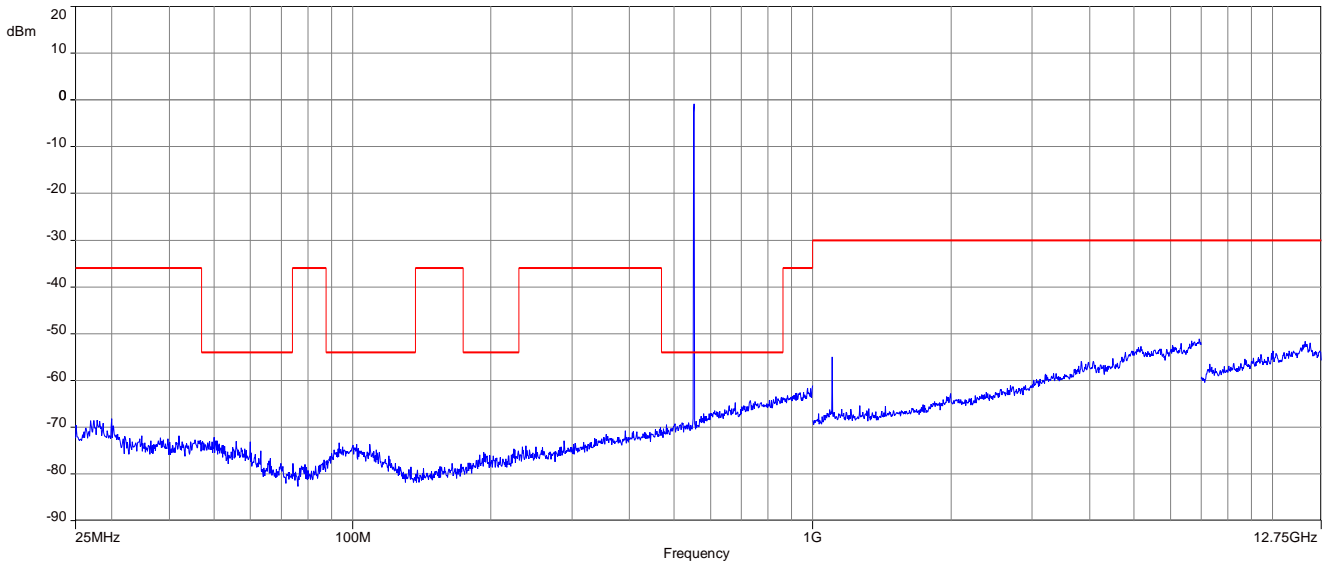

Plot 8: R4-9, 580.000 MHz, 25 MHz – 12.75 GHz

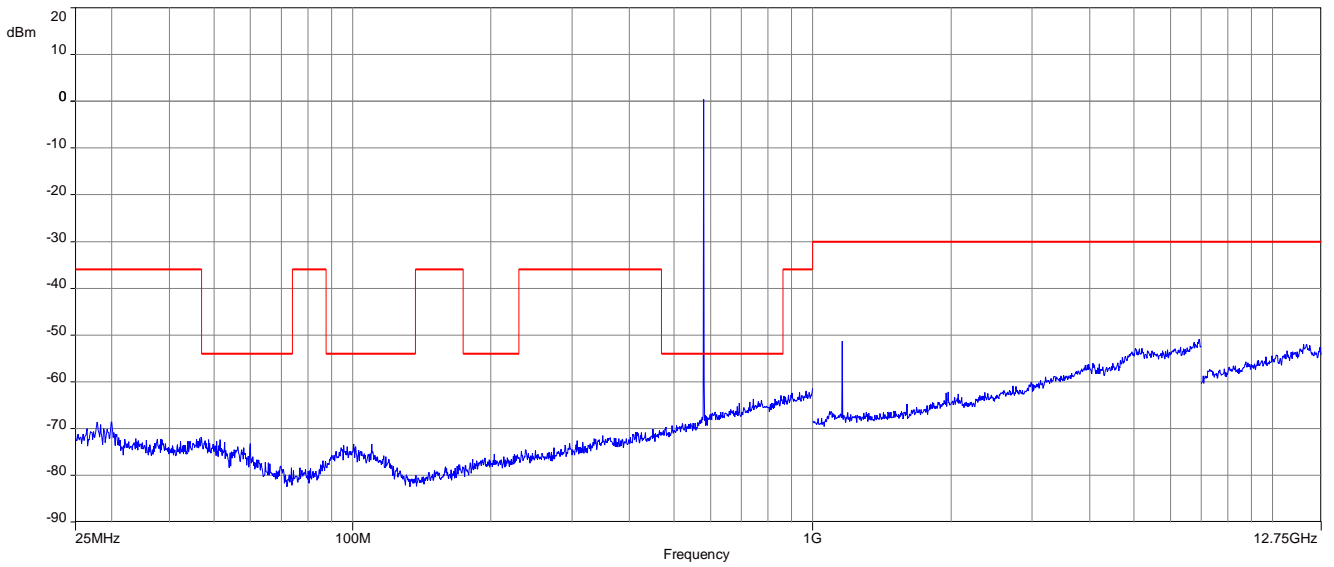

12.5 Necessary bandwidth (BN) for digital systems

Measurement:

Measurement parameter	
Detector:	Peak / Average (-90 dBc point only)
Sweep time:	Auto
Resolution bandwidth:	1 kHz
Video bandwidth:	1 kHz
Span:	$f_c - 1 \text{ MHz}$ to $f_c + 1 \text{ MHz}$ (2 MHz)
Trace mode:	Max hold/view
EUT:	CW and MC
Test setup:	See sub clause 7.2 - A
Measurement uncertainty:	See sub clause 9

Limits: according to ETSI EN 300 422-1 v1.4.2

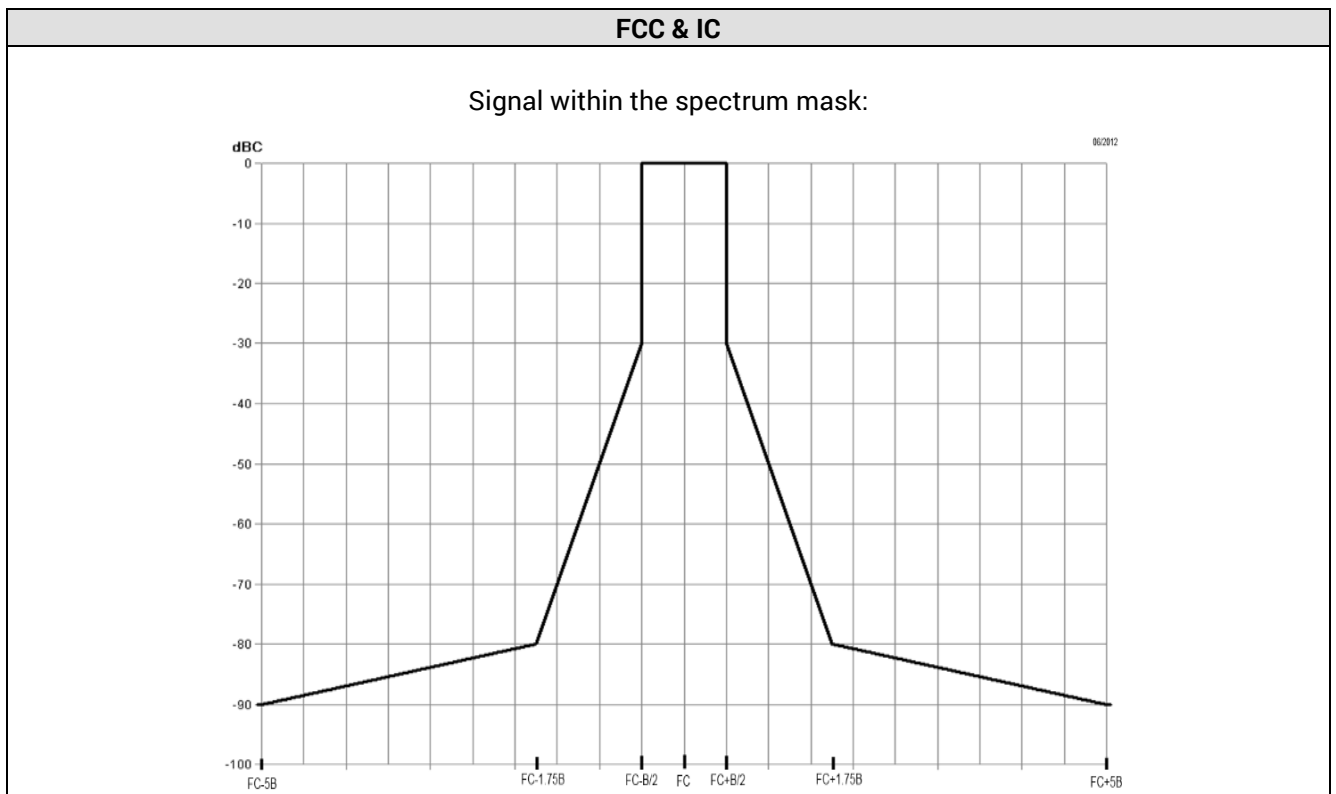

Plots:

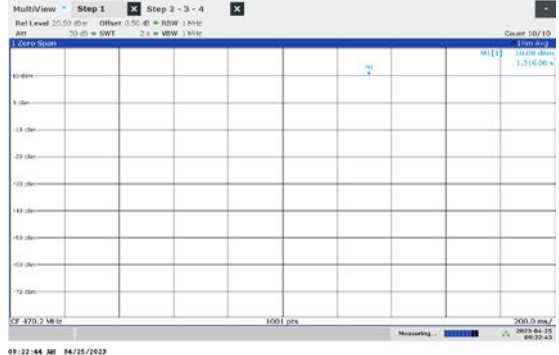
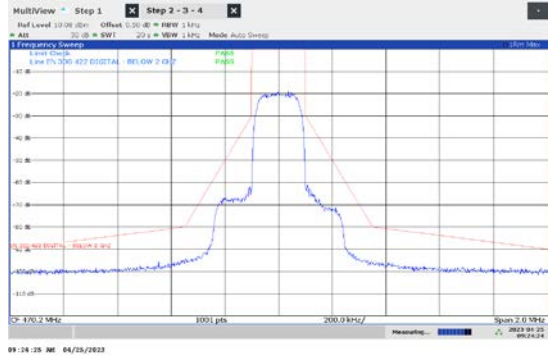
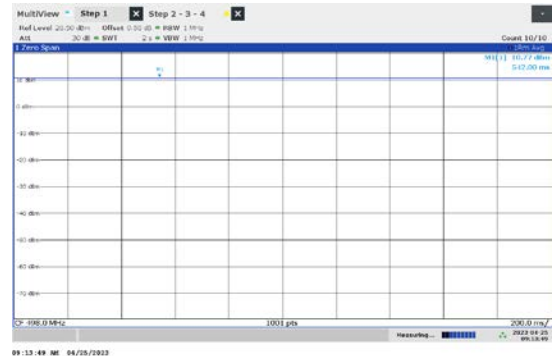
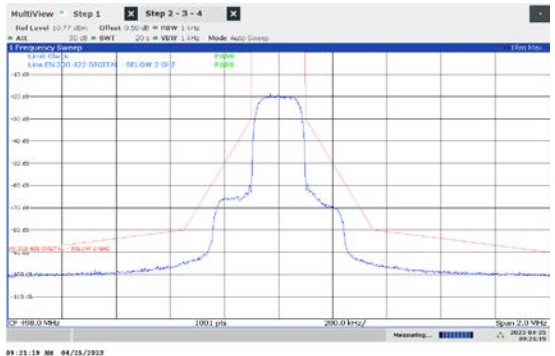
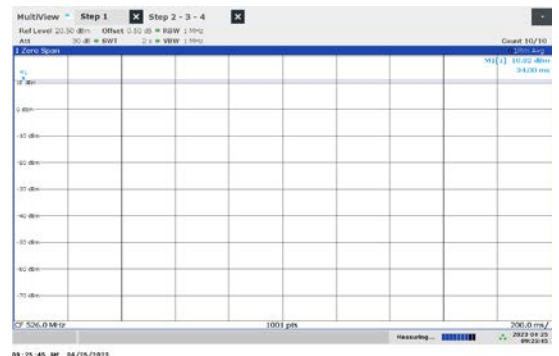
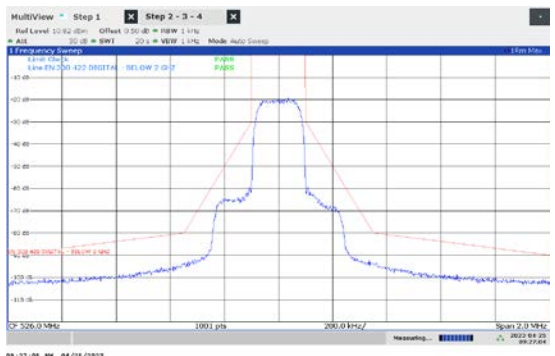
Frequency	Carrier power	Spectrum mask for digital systems
470.2 MHz		
498.0 MHz		
526.0 MHz		

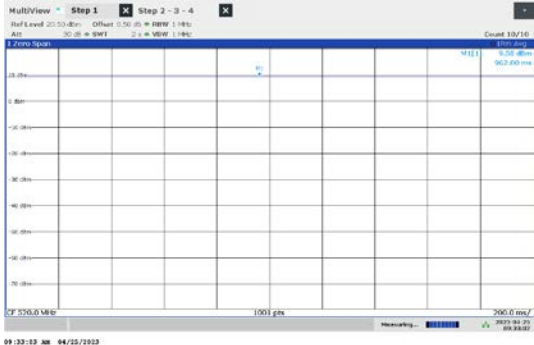
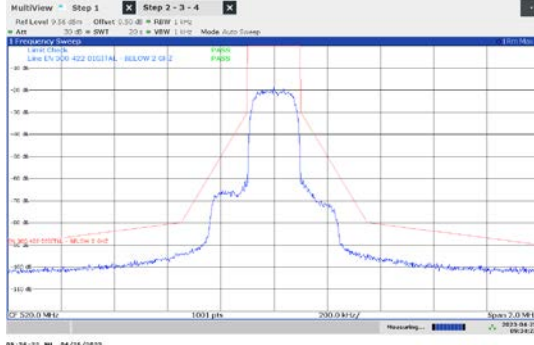
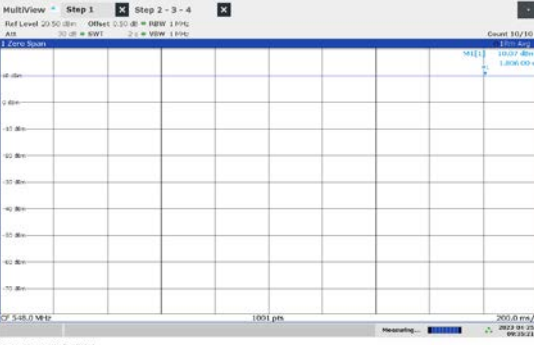
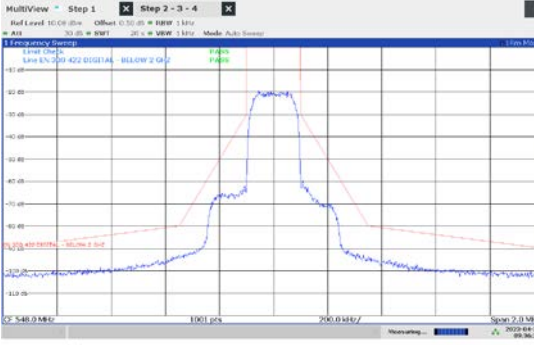
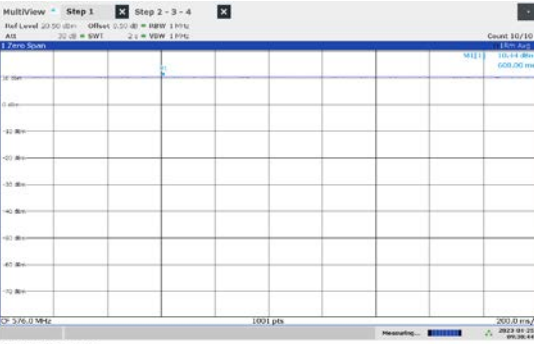
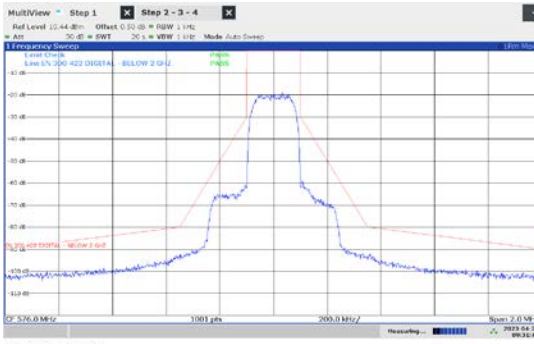
Frequency	Carrier power	Spectrum mask for digital systems
520.0 MHz	 <p>Carrier power plot for 520.0 MHz. The plot shows a single sharp peak at 520.0 MHz. The y-axis represents power in dBm, ranging from -70 to 18. The x-axis represents frequency in MHz, ranging from 519.9 to 520.1. The peak power is approximately 18 dBm. The plot includes a grid and various measurement parameters such as 'Count 10/10', 'Ref Level 20.50 dBm', and 'Offset 0.50 dB'.</p>	 <p>Spectrum mask plot for 520.0 MHz. The plot shows the measured signal (blue line) and the required spectrum mask (red lines). The y-axis represents power in dBm, ranging from -100 to 18. The x-axis represents frequency in MHz, ranging from 519.9 to 520.1. The measured signal is within the mask limits. The plot includes a grid and various measurement parameters such as 'Count 10/10', 'Ref Level 20.50 dBm', and 'Offset 0.50 dB'.</p>
548.0 MHz	 <p>Carrier power plot for 548.0 MHz. The plot shows a single sharp peak at 548.0 MHz. The y-axis represents power in dBm, ranging from -70 to 48. The x-axis represents frequency in MHz, ranging from 547.9 to 548.1. The peak power is approximately 48 dBm. The plot includes a grid and various measurement parameters such as 'Count 10/10', 'Ref Level 20.50 dBm', and 'Offset 0.50 dB'.</p>	 <p>Spectrum mask plot for 548.0 MHz. The plot shows the measured signal (blue line) and the required spectrum mask (red lines). The y-axis represents power in dBm, ranging from -100 to 48. The x-axis represents frequency in MHz, ranging from 547.9 to 548.1. The measured signal is within the mask limits. The plot includes a grid and various measurement parameters such as 'Count 10/10', 'Ref Level 20.50 dBm', and 'Offset 0.50 dB'.</p>
576.0 MHz	 <p>Carrier power plot for 576.0 MHz. The plot shows a single sharp peak at 576.0 MHz. The y-axis represents power in dBm, ranging from -70 to 38. The x-axis represents frequency in MHz, ranging from 575.9 to 576.1. The peak power is approximately 38 dBm. The plot includes a grid and various measurement parameters such as 'Count 10/10', 'Ref Level 20.50 dBm', and 'Offset 0.50 dB'.</p>	 <p>Spectrum mask plot for 576.0 MHz. The plot shows the measured signal (blue line) and the required spectrum mask (red lines). The y-axis represents power in dBm, ranging from -100 to 38. The x-axis represents frequency in MHz, ranging from 575.9 to 576.1. The measured signal is within the mask limits. The plot includes a grid and various measurement parameters such as 'Count 10/10', 'Ref Level 20.50 dBm', and 'Offset 0.50 dB'.</p>

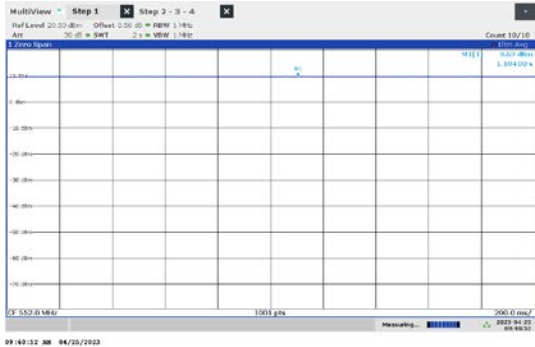
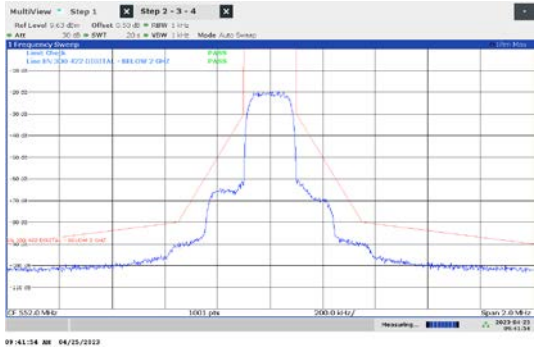
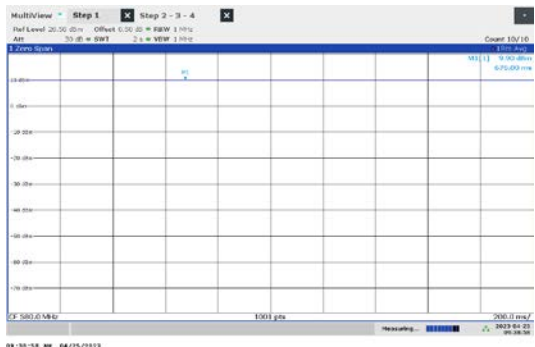
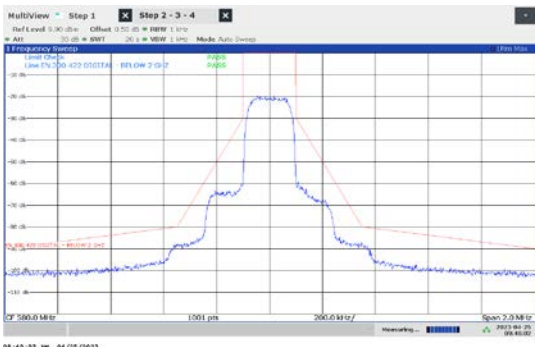
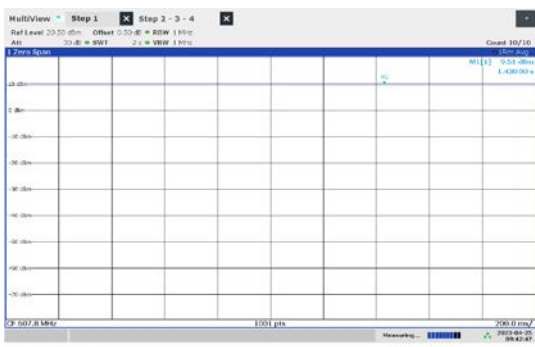
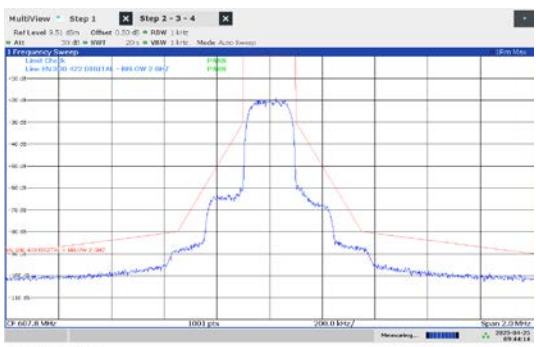
Frequency	Carrier power	Spectrum mask for digital systems
552.0 MHz	 <p>Carrier power plot for 552.0 MHz. The plot shows a flat line at approximately -100 dBm across the entire span. The y-axis ranges from -120 dBm to 10 dBm, and the x-axis ranges from 0 to 200 kHz. The plot title is 'MultiView - Step 1 Step 2 - 3 - 4'. Parameters include Ref Level: 20.00 dBm, Offset: 0.00 dB, RBW: 1 kHz, and Span: 200.0 MHz.</p>	 <p>Spectrum mask plot for 552.0 MHz. The plot shows a blue signal trace within a red mask. The signal is centered at 552.0 MHz with a bandwidth of approximately 20 MHz. The y-axis ranges from -120 dBm to 10 dBm, and the x-axis ranges from 0 to 200 kHz. The plot title is 'MultiView - Step 1 Step 2 - 3 - 4'. Parameters include Ref Level: 0.00 dBm, Offset: 0.00 dB, RBW: 1 kHz, and Span: 200.0 MHz.</p>
580.0 MHz	 <p>Carrier power plot for 580.0 MHz. The plot shows a flat line at approximately -100 dBm across the entire span. The y-axis ranges from -120 dBm to 10 dBm, and the x-axis ranges from 0 to 200 kHz. The plot title is 'MultiView - Step 1 Step 2 - 3 - 4'. Parameters include Ref Level: 20.00 dBm, Offset: 0.00 dB, RBW: 1 kHz, and Span: 200.0 MHz.</p>	 <p>Spectrum mask plot for 580.0 MHz. The plot shows a blue signal trace within a red mask. The signal is centered at 580.0 MHz with a bandwidth of approximately 20 MHz. The y-axis ranges from -120 dBm to 10 dBm, and the x-axis ranges from 0 to 200 kHz. The plot title is 'MultiView - Step 1 Step 2 - 3 - 4'. Parameters include Ref Level: 0.00 dBm, Offset: 0.00 dB, RBW: 1 kHz, and Span: 200.0 MHz.</p>
607.8 MHz	 <p>Carrier power plot for 607.8 MHz. The plot shows a flat line at approximately -100 dBm across the entire span. The y-axis ranges from -120 dBm to 10 dBm, and the x-axis ranges from 0 to 200 kHz. The plot title is 'MultiView - Step 1 Step 2 - 3 - 4'. Parameters include Ref Level: 20.00 dBm, Offset: 0.00 dB, RBW: 1 kHz, and Span: 200.0 MHz.</p>	 <p>Spectrum mask plot for 607.8 MHz. The plot shows a blue signal trace within a red mask. The signal is centered at 607.8 MHz with a bandwidth of approximately 20 MHz. The y-axis ranges from -120 dBm to 10 dBm, and the x-axis ranges from 0 to 200 kHz. The plot title is 'MultiView - Step 1 Step 2 - 3 - 4'. Parameters include Ref Level: 0.00 dBm, Offset: 0.00 dB, RBW: 1 kHz, and Span: 200.0 MHz.</p>

13 Observations

No observations except those reported with the single test cases have been made.

14 Glossary

EUT	Equipment under test
DUT	Device under test
UUT	Unit under test
GUE	GNSS User Equipment
ETSI	European Telecommunications Standards Institute
EN	European Standard
FCC	Federal Communications Commission
FCC ID	Company Identifier at FCC
IC	Industry Canada
PMN	Product marketing name
HMN	Host marketing name
HVIN	Hardware version identification number
FVIN	Firmware version identification number
EMC	Electromagnetic Compatibility
HW	Hardware
SW	Software
Inv. No.	Inventory number
S/N or SN	Serial number
C	Compliant
NC	Not compliant
NA	Not applicable
NP	Not performed
PP	Positive peak
QP	Quasi peak
AVG	Average
OC	Operating channel
OCW	Operating channel bandwidth
OBW	Occupied bandwidth
OOB	Out of band
DFS	Dynamic frequency selection
CAC	Channel availability check
OP	Occupancy period
NOP	Non occupancy period
DC	Duty cycle
PER	Packet error rate
CW	Clean wave
MC	Modulated carrier
WLAN	Wireless local area network
RLAN	Radio local area network
DSSS	Dynamic sequence spread spectrum
OFDM	Orthogonal frequency division multiplexing
FHSS	Frequency hopping spread spectrum
GNSS	Global Navigation Satellite System
C/N₀	Carrier to noise-density ratio, expressed in dB-Hz

15 Document history

Version	Applied changes	Date of release
-/-	Initial release	2023-04-28

16 Accreditation Certificate – D-PL-12076-01-04

first page	last page
 <p>The first page of the accreditation certificate features the DAKKS logo (Deutsche Akkreditierungsstelle) and the text: "Deutsche Akkreditierungsstelle GmbH", "Entrusted according to Section 8 subsection 1 AkkStelleG in connection with Section 1 subsection 1 AkkStelleGBV Signatory to the Multilateral Agreements of EA, ILAC and IAF for Mutual Recognition", "Accreditation" with the German eagle emblem, and "The Deutsche Akkreditierungsstelle GmbH attests that the testing laboratory CTC advanced GmbH Untertürkheimer Straße 6-10, 66117 Saarbrücken is competent under the terms of DIN EN ISO/IEC 17025:2018 to carry out tests in the following fields: Telecommunication (TC) and Electromagnetic Compatibility (EMC) for Canadian Standards". It also includes the registration number "D-PL-12076-01-04", a signature of the Head of Division, and a date of "Frankfurt am Main, 09.06.2020".</p>	 <p>The last page of the accreditation certificate lists the offices: "Office Berlin Spittelmarkt 10 10117 Berlin", "Office Frankfurt am Main Europa-Allee 52 60327 Frankfurt am Main", and "Office Braunschweig Bundesallee 100 38116 Braunschweig". It contains a disclaimer: "The publication of extracts of the accreditation certificate is subject to the prior written approval by Deutsche Akkreditierungsstelle GmbH (DAKKS). Exempted is the unchanged form of separate disseminations of the cover sheet by the conformity assessment body mentioned overleaf." and a statement: "No impression shall be made that the accreditation also extends to fields beyond the scope of accreditation attested by DAKKS." It also mentions the accreditation was granted pursuant to the Act on the Accreditation Body (AkkStelleG) of 31 July 2009 and provides websites for up-to-date membership information: EA: www.european-accreditation.org, ILAC: www.ilac.org, IAF: www.iaf.nu.</p>

Note: The current certificate annex is published on the websites (link see below).

<https://www.dakks.de/files/data/as/pdf/D-PL-12076-01-04e.pdf>

OR

https://ctcadvanced.com/app/uploads/2020/06/D-PL-12076-01-04_Canada_TCEMC.pdf

17 Accreditation Certificate – D-PL-12076-01-05

first page	last page			
 <p>Deutsche Akkreditierungsstelle GmbH</p> <p>Entrusted according to Section 8 subsection 1 AkkStelleG in connection with Section 1 subsection 1 AkkStelleGBV Signatory to the Multilateral Agreements of EA, ILAC and IAF for Mutual Recognition</p> <p>Accreditation </p> <p>The Deutsche Akkreditierungsstelle GmbH attests that the testing laboratory CTC advanced GmbH Untertürkheimer Straße 6-10, 66117 Saarbrücken is competent under the terms of DIN EN ISO/IEC 17025:2018 to carry out tests in the following fields: Telecommunication (FCC Requirements)</p> <p>The accreditation certificate shall only apply in connection with the notice of accreditation of 09.06.2020 with the accreditation number D-PL-12076-01. It comprises the cover sheet, the reverse side of the cover sheet and the following annex with a total of 05 pages. Registration number of the certificate: D-PL-12076-01-05</p> <p>Frankfurt am Main, 09.06.2020  by order of Dipl.-Ing. (FH) Stefan Egner Head of Division</p> <p><small>The certificate together with its annex reflects the status at the time of the date of issue. The current status of the scope of accreditation can be found in the database of accredited bodies of Deutsche Akkreditierungsstelle GmbH. https://www.dakks.de/en/content/accredited-bodies-dakks file name: mch04d</small></p>	<p>Deutsche Akkreditierungsstelle GmbH</p> <table border="0"> <tr> <td>Office Berlin Spittelmarkt 10 10117 Berlin</td> <td>Office Frankfurt am Main Europa-Allee 52 60327 Frankfurt am Main</td> <td>Office Braunschweig Bundesallee 100 38116 Braunschweig</td> </tr> </table> <p>The publication of extracts of the accreditation certificate is subject to the prior written approval by Deutsche Akkreditierungsstelle GmbH (DAkKS). Exempted is the unchanged form of separate disseminations of the cover sheet by the conformity assessment body mentioned overleaf.</p> <p>No impression shall be made that the accreditation also extends to fields beyond the scope of accreditation attested by DAkKS.</p> <p>The accreditation was granted pursuant to the Act on the Accreditation Body (AkkStelleG) of 31 July 2009 (Federal Law Gazette I p. 2625) and the Regulation (EC) No 765/2008 of the European Parliament and of the Council of 9 July 2008 setting out the requirements for accreditation and market surveillance relating to the marketing of products (Official Journal of the European Union L 218 of 9 July 2008, p. 30). DAkKS is a signatory to the Multilateral Agreements for Mutual Recognition of the European co-operation for Accreditation (EA), International Accreditation Forum (IAF) and International Laboratory Accreditation Cooperation (ILAC). The signatories to these agreements recognise each other's accreditations.</p> <p>The up-to-date state of membership can be retrieved from the following websites: EA: www.european-accreditation.org ILAC: www.ilac.org IAF: www.iaf.nu</p>	Office Berlin Spittelmarkt 10 10117 Berlin	Office Frankfurt am Main Europa-Allee 52 60327 Frankfurt am Main	Office Braunschweig Bundesallee 100 38116 Braunschweig
Office Berlin Spittelmarkt 10 10117 Berlin	Office Frankfurt am Main Europa-Allee 52 60327 Frankfurt am Main	Office Braunschweig Bundesallee 100 38116 Braunschweig		

Note: The current certificate annex is published on the websites (link see below).

<https://www.dakks.de/files/data/as/pdf/D-PL-12076-01-05e.pdf>

or

https://ctcadvanced.com/app/uploads/2020/06/D-PL-12076-01-05_TCB_USA.pdf

END OF TEST REPORT