

Testing Laboratory

CTC advanced GmbH

Untertuerkheimer Strasse 6 – 10

66117 Saarbruecken/Germany

Phone: + 49 681 5 98 - 0

Fax: + 49 681 5 98 - 9075

Internet: <http://www.ctcadvanced.com>

e-mail: mail@ctcadvanced.com

Accredited Test Laboratory:

The testing laboratory (area of testing) is accredited according to DIN EN ISO/IEC 17025 (2005) by the Deutsche Akkreditierungsstelle GmbH (DAKKS)

The accreditation is valid for the scope of testing procedures as stated in the accreditation certificate with the registration number: D-PL-12076-01-03

Applicant

Sennheiser electronic GmbH & Co. KG

Am Labor 1

30900 Wedemark/GERMANY

Phone: +49 5130 600-0

Contact: Nils Knauer

e-mail: Nils.Knauer@sennheiser.com

Phone: +49 5130/600-9524

Manufacturer

Sennheiser electronic GmbH & Co. KG

Am Labor 1

30900 Wedemark/GERMANY

Test Standards

IEEE 1528-2013

Recommended Practice for Determining the Peak Spatial-Average Specific Absorption Rate (SAR) in the Human Head from Wireless Communications Devices: Measurement Techniques

RSS-102 Issue 5

Radio Frequency Exposure Compliance of Radiocommunication Apparatus (All Frequency Bands)

For further applied test standards please refer to section 3 of this test report.

Test Item

Kind of test item:

Wireless Microphone

Device type:

portable device

Model name:

SKM 2000

S/N serial number:

1064289102 / 1084289123

FCC-ID:

DMOSKM2000

IC:

2099A-SKM2000

Product Marketing Name (PMN):

SKM 2000

Hardware Version Identification No. (HVIN):

SKM 2000; SKM 2000XP

Firmware Version Identification No. (FVIN):

1.8.1

Hardware status:

525479_21

Software status:

Software status: 1.8.1

Frequency:

see technical details

Antenna:

integrated antenna

Battery option:

2 x 1.5 V AA Batteries

Test sample status:

identical prototype

Exposure category:

general population / uncontrolled environment

This test report is electronically signed and valid without handwriting signature. For verification of the electronic signatures, the public keys can be requested at the testing laboratory.

Test Report authorised:

Alexander Hnatovskiy
Lab Manager
Radio Communications & EMC

Test performed:

Marco Scigliano
Testing Manager
Radio Communications & EMC

1 Table of contents

1 Table of contents.....2

2 General information3

2.1 Notes and disclaimer3

2.2 Application details3

2.3 Statement of compliance.....3

2.4 Technical details4

3 Test standards/ procedures references.....5

3.1 RF exposure limits6

4 Summary of Measurement Results7

5 Test Environment7

6 Test Set-up.....8

6.1 Measurement system.....8

 6.1.1 System Description.....8

 6.1.2 Test environment.....9

 6.1.3 Probe description.....9

 6.1.4 Phantom description.....10

 6.1.5 Device holder description11

 6.1.6 Scanning procedure12

 6.1.7 Spatial Peak SAR Evaluation13

 6.1.8 Data Storage and Evaluation.....14

 6.1.9 Tissue simulating liquids: dielectric properties16

 6.1.10 Tissue simulating liquids: parameters16

 6.1.11 Measurement uncertainty evaluation for SAR test.....17

 6.1.12 Measurement uncertainty evaluation for System Check.....20

 6.1.13 System check21

 6.1.14 System check procedure.....22

 6.1.15 System validation23

7 Detailed Test Results24

7.1 Conducted power measurements.....24

7.2 SAR test results.....24

 7.2.1 General description of test procedures24

 7.2.2 Results overview24

8 Test equipment and ancillaries used for tests25

9 Observations25

Annex A: System performance check.....26

Annex B: DASY5 measurement results.....28

Annex B.1: Liquid depth.....30

Annex C: Photo documentation31

Annex D: Calibration parameters.....31

Annex E: RSS-102 Annex A and B.....31

Annex F: Document History32

Annex G: Further Information32

2 General information

2.1 Notes and disclaimer

The test results of this test report relate exclusively to the test item specified in this test report. CTC advanced GmbH does not assume responsibility for any conclusions and generalisations drawn from the test results with regard to other specimens or samples of the type of the equipment represented by the test item. The test report may only be reproduced or published in full. Reproduction or publication of extracts from the report requires the prior written approval of CTC advanced GmbH.

This test report is electronically signed and valid without handwriting signature. For verification of the electronic signatures, the public keys can be requested at the testing laboratory.

The testing service provided by CTC advanced GmbH has been rendered under the current "General Terms and Conditions for CTC advanced GmbH".

CTC advanced GmbH will not be liable for any loss or damage resulting from false, inaccurate, inappropriate or incomplete product information provided by the customer.

Under no circumstances does the CTC advanced GmbH test report include any endorsement or warranty regarding the functionality, quality or performance of any other product or service provided.

Under no circumstances does the CTC advanced GmbH test report include or imply any product or service warranties from CTC advanced GmbH, including, without limitation, any implied warranties of merchantability, fitness for purpose, or non-infringement, all of which are expressly disclaimed by CTC advanced GmbH.

All rights and remedies regarding vendor's products and services for which CTC advanced GmbH has prepared this test report shall be provided by the party offering such products or services and not by CTC advanced GmbH.

In no case this test report can be considered as a Letter of Approval.

2.2 Application details

Date of receipt of order:	2019-01-16
Date of receipt of test item:	2019-01-01
Start of test:	2019-01-04
End of test:	2019-01-04

2.3 Statement of compliance

The SAR values found for the SKM 2000 Wireless Microphone are below the maximum recommended levels of 1.6 W/Kg as averaged over any 1 g tissue according to the FCC rule §2.1093, the ANSI/IEEE C 95.1:1992, the NCRP Report Number 86 for uncontrolled environment, according to the Health Canada's Safety Code 6 and the Industry Canada Radio Standards Specification RSS-102 for General Population/Uncontrolled exposure.

2.4 Technical details

Device	Frequency [MHz]	Serial No.	Type
Aw+	470-558	1064289102	Wireless Microphone MODEL: SKM 2000
Gw1	558-608	1084289123	

3 Test standards/ procedures references

Test Standard	Version	Test Standard Description
IEEE 1528-2013	2013-06	Recommended Practice for Determining the Peak Spatial-Average Specific Absorption Rate (SAR) in the Human Head from Wireless Communications Devices: Measurement Techniques
RSS-102 Issue 5	2015-03	Radio Frequency Exposure Compliance of Radiocommunication Apparatus (All Frequency Bands)
Canada's Safety Code No. 6	2015-06	Limits of Human Exposure to Radiofrequency Electromagnetic Fields in the Frequency Range from 3 kHz to 300 GHz
IEEE Std. C95-3	2002	IEEE Recommended Practice for the Measurement of Potentially Hazardous Electromagnetic Fields – RF and Microwave
IEEE Std. C95-1	2005	IEEE Standard for Safety Levels with Respect to Human Exposure to Radio Frequency Electromagnetic Fields, 3 kHz to 300 GHz.
IEC 62209-2	2010	Human exposure to radio frequency fields from hand-held and bodymounted wireless communication devices. Human models, instrumentation, and procedures. Procedure to determine the specific absorption rate (SAR) for wireless communication devices used in close proximity to the human body (frequency range of 30 MHz to 6 GHz)
FCC KDBs:		
KDB 865664D01v01	August 7, 2015	FCC OET SAR measurement requirements 100 MHz to 6 GHz
KDB 865664D02v01	October 23, 2015	RF Exposure Compliance Reporting and Documentation Considerations
KDB 447498D01v06	October 23, 2015	Mobile and Portable Devices RF Exposure Procedures and Equipment Authorization Policies
KDB 648474D04v01	October 23, 2015	SAR Evaluation Considerations for Wireless Handsets

3.1 RF exposure limits

Human Exposure	Uncontrolled Environment General Population	Controlled Environment Occupational
Spatial Peak SAR* (Brain and Trunk)	1.60 mW/g	8.00 mW/g
Spatial Average SAR** (Whole Body)	0.08 mW/g	0.40 mW/g
Spatial Peak SAR*** (Hands/Feet/Ankle/Wrist)	4.00 mW/g	20.00 mW/g

Table 1: RF exposure limits

The limit applied in this test report is shown in bold letters

Notes:

* The Spatial Peak value of the SAR averaged over any 1 gram of tissue (defined as a tissue volume in the shape of a cube) and over the appropriate averaging time

** The Spatial Average value of the SAR averaged over the whole body.

*** The Spatial Peak value of the SAR averaged over any 10 grams of tissue (defined as a tissue volume in the shape of a cube) and over the appropriate averaging time.

Uncontrolled Environments are defined as locations where there is the exposure of individuals who have no knowledge or control of their exposure.

Controlled Environments are defined as locations where there is exposure that may be incurred by persons who are aware of the potential for exposure, (i.e. as a result of employment or occupation).

4 Summary of Measurement Results

<input checked="" type="checkbox"/>	No deviations from the technical specifications ascertained	
<input type="checkbox"/>	Deviations from the technical specifications ascertained	
Maximum SAR value (W/kg)		
	reported	limit
body worn 0 mm distance for 1g	1.273	1.6
extremity 0 mm distance for 10g	0.675	4.0

5 Test Environment

Ambient temperature:	20 – 24 °C
Tissue Simulating liquid:	20 – 24 °C
Relative humidity content:	40 – 50 %
Air pressure:	not relevant for this kind of testing
Power supply:	230 V / 50 Hz

Exact temperature values for each test are shown in the table(s) under 7.1 and/or on the measurement plots.

6 Test Set-up

6.1 Measurement system

6.1.1 System Description

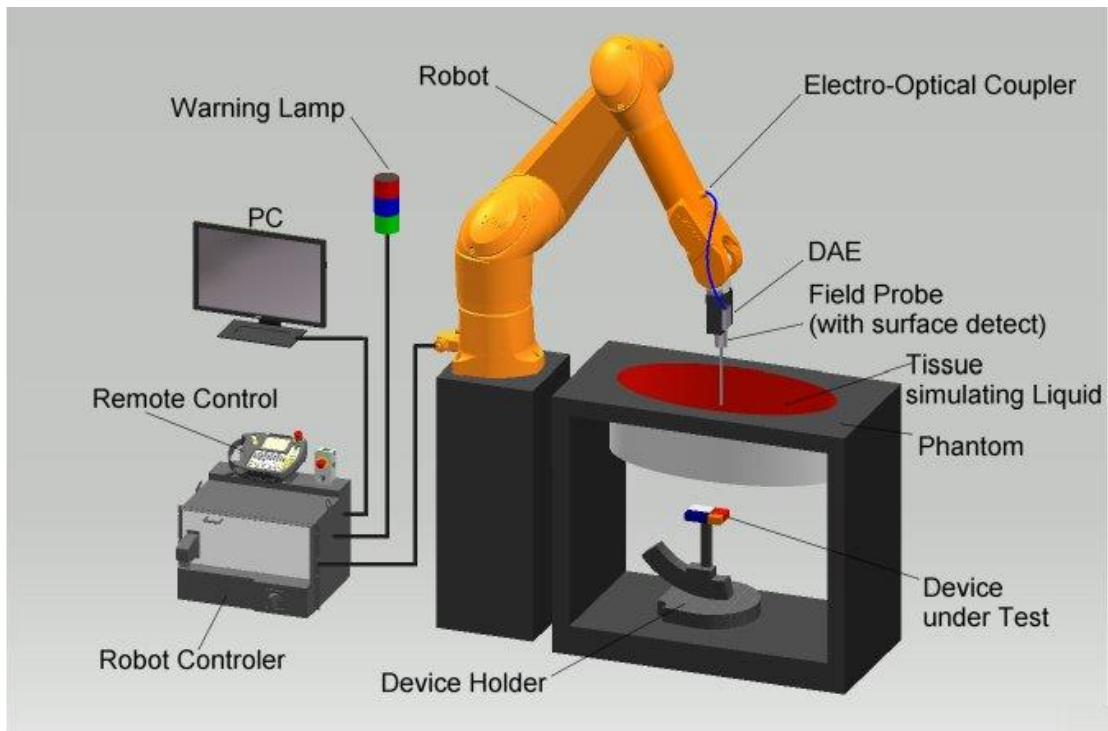

- The DAS system for performing compliance tests consists of the following items:
- A standard high precision 6-axis robot (Stäubli RX/TX family) with controller and software. An arm extension for accommodating the data acquisition electronics (DAE).
- A dosimetric probe, i.e. an isotropic E-field probe optimized and calibrated for usage in tissue simulating liquid.
- A data acquisition electronic (DAE) which performs the signal amplification, signal multiplexing, AD-conversion, offset measurements, mechanical surface detection, collision detection, etc. The unit is battery powered with standard or rechargeable batteries. The signal is optically transmitted to the EOC.
- The Electro-Optical Coupler (EOC) performs the conversion from the optical into a digital electric signal of the DAE. The EOC is connected to the DAS measurement server.
- The DAS measurement server, which performs all real-time data evaluation for field measurements and surface detection, controls robot movements and handles safety operation. A computer operating Windows 7.
- DAS software and SEMCAD data evaluation software.
- Remote control with teach panel and additional circuitry for robot safety such as warning lamps, etc.
- The generic twin phantom enabling the testing of left-hand and right-hand usage.
- The triple flat and eli phantom for the testing of handheld and body-mounted wireless devices.
- The device holder for handheld mobile phones and mounting device adaptor for laptops
- Tissue simulating liquid mixed according to the given recipes.
- System check dipoles allowing to validate the proper functioning of the system.

6.1.2 Test environment

The DASY measurement system is placed in a laboratory room within an environment which avoids influence on SAR measurements by ambient electromagnetic fields and any reflection from the environment. The pictures at the beginning of the photo documentation show a complete view of the test environment. The system allows the measurement of SAR values larger than 0.005 mW/g.

6.1.3 Probe description

Isotropic E-Field Probe ES3DV3 for Dosimetric Measurements	
Technical data according to manufacturer information	
Construction	Symmetrical design with triangular core Interleaved sensors Built-in shielding against static charges PEEK enclosure material (resistant to organic solvents, e.g., butyl diglycol)
Calibration	Calibration certificate in Appendix D
Frequency	10 MHz to 3 GHz (dosimetry); Linearity: ± 0.2 dB (30 MHz to 3 GHz)
Directivity	± 0.2 dB in HSL (rotation around probe axis) ± 0.3 dB in HSL (rotation normal to probe axis)
Dynamic range	5 μ W/g to > 100 mW/g; Linearity: ± 0.2 dB
Dimensions	Overall length: 330 mm Tip length: 20 mm Body diameter: 12 mm Tip diameter: 3.9 mm Distance from probe tip to dipole centers: 2.0 mm
Application	General dosimetry up to 3 GHz Compliance tests of mobile phones Fast automatic scanning in arbitrary phantoms (ES3DV3)
Isotropic E-Field Probe EX3DV4 for Dosimetric Measurements	
Technical data according to manufacturer information	
Construction	Symmetrical design with triangular core Interleaved sensors Built-in shielding against static charges PEEK enclosure material (resistant to organic solvents, e.g., DGBE)
Calibration	ISO/IEC 17025 calibration service available.
Frequency	10 MHz to >6 GHz (dosimetry); Linearity: ± 0.2 dB (30 MHz to 6 GHz)
Directivity	± 0.3 dB in HSL (rotation around probe axis) ± 0.5 dB in tissue material (rotation normal to probe axis)
Dynamic range	10 μ W/g to > 100 mW/g; Linearity: ± 0.2 dB (noise: typically <1 μ W/g)
Dimensions	Overall length: 337 mm (Tip: 20mm) Tip length: 2.5 mm (Body: 12mm) Typical distance from probe tip to dipole centers: 1mm
Application	High precision dosimetric measurements in any exposure scenario (e.g., very strong gradient fields). Only probe which enables compliance testing for frequencies up to 6 GHz with precision of better 30%.

6.1.4 Phantom description

The used SAM Phantom meets the requirements specified in FCC KDB865664 D01 for Specific Absorption Rate (SAR) measurements.

The phantom consists of a fibreglass shell integrated in a wooden table. It allows left-hand and right-hand head as well as body-worn measurements with a maximum liquid depth of 18 cm in head position and 22 cm in planar position (body measurements). The thickness of the Phantom shell is 2 mm +/- 0.1 mm.

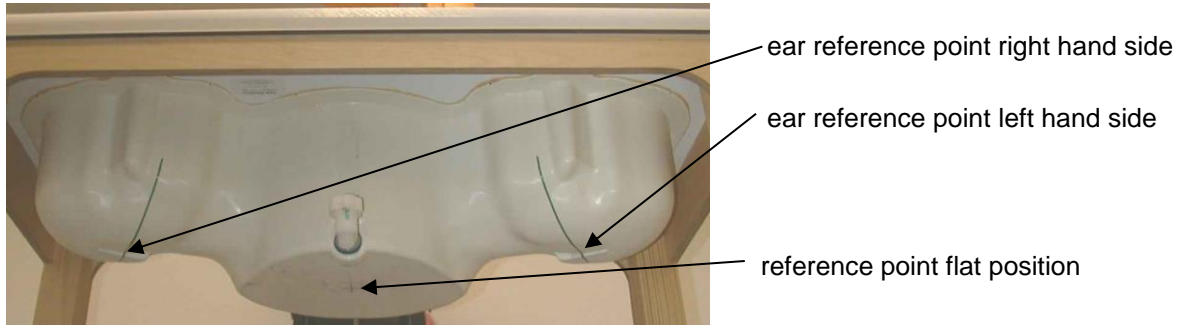

Triple Modular Phantom consists of three identical modules which can be installed and removed separately without emptying the liquid. It includes three reference points for phantom installation. Covers prevent evaporation of the liquid. Phantom material is resistant to DGBE based tissue simulating liquids.

6.1.5 Device holder description

The DASY device holder has two scales for device rotation (with respect to the body axis) and the device inclination (with respect to the line between the ear openings). The plane between the ear openings and the mouth tip has a rotation angle of 65°. The bottom plate contains three pair of bolts for locking the device holder. The device holder positions are adjusted to the standard measurement positions in the three sections. This device holder is used for standard mobile phones or PDA's only. If necessary an additional support of polystyrene material is used.



Larger DUT's (e.g. notebooks) cannot be tested using this device holder. Instead a support of bigger polystyrene cubes and thin polystyrene plates is used to position the DUT in all relevant positions to find and measure spots with maximum SAR values.

Therefore those devices are normally only tested at the flat part of the SAM.

6.1.6 Scanning procedure

- The DASY installation includes predefined files with recommended procedures for measurements and system check. They are read-only document files and destined as fully defined but unmeasured masks. All test positions (head or body-worn) are tested with the same configuration of test steps differing only in the grid definition for the different test positions.
- The „reference“ and „drift“ measurements are located at the beginning and end of the batch process. They measure the field drift at one single point in the liquid over the complete procedure. The indicated drift is mainly the variation of the DUT's output power and should vary max. +/- 5 %.
- The highest integrated SAR value is the main concern in compliance test applications. These values can mostly be found at the inner surface of the phantom and cannot be measured directly due to the sensor offset in the probe. To extrapolate the surface values, the measurement distances to the surface must be known accurately. A distance error of 0.5mm could produce SAR errors of 6% at 1800 MHz. Using predefined locations for measurements is not accurate enough. Any shift of the phantom (e.g., slight deformations after filling it with liquid) would produce high uncertainties. For an automatic and accurate detection of the phantom surface, the DASY5 system uses the mechanical surface detection. The detection is always at touch, but the probe will move backward from the surface the indicated distance before starting the measurement.
- The „area scan“ measures the SAR above the DUT or verification dipole on a parallel plane to the surface. It is used to locate the approximate location of the peak SAR with 2D spline interpolation. The robot performs a stepped movement along one grid axis while the local electrical field strength is measured by the probe. The probe is touching the surface of the SAM during acquisition of measurement values. The scan uses different grid spacings for different frequency measurements. Standard grid spacing for head measurements in frequency ranges ≤ 2 GHz is 15 mm in x- and y-dimension. For higher frequencies a finer resolution is needed, thus for the grid spacing is reduced according the following table:

Area scan grid spacing for different frequency ranges	
Frequency range	Grid spacing
≤ 2 GHz	≤ 15 mm
2 – 4 GHz	≤ 12 mm
4 – 6 GHz	≤ 10 mm

Grid spacing and orientation have no influence on the SAR result. For special applications where the standard scan method does not find the peak SAR within the grid, e.g. mobile phones with flip cover, the grid can be adapted in orientation. Results of this coarse scan are shown in annex B.

- A „zoom scan“ measures the field in a volume around the 2D peak SAR value acquired in the previous „coarse“ scan. It uses a fine meshed grid where the robot moves the probe in steps along all the 3 axis (x, y and z-axis) starting at the bottom of the Phantom. The grid spacing for the cube measurement is varied according to the measured frequency range, the dimensions are given in the following table:

Zoom scan grid spacing and volume for different frequency ranges			
Frequency range	Grid spacing for x, y axis	Grid spacing for z axis	Minimum zoom scan volume
≤ 2 GHz	≤ 8 mm	≤ 5 mm	≥ 30 mm
2 – 3 GHz	≤ 5 mm*	≤ 5 mm	≥ 28 mm
3 – 4 GHz	≤ 5 mm*	≤ 4 mm	≥ 28 mm
4 – 5 GHz	≤ 4 mm*	≤ 3 mm	≥ 25 mm
5 – 6 GHz	≤ 4 mm*	≤ 2 mm	≥ 22 mm

* When zoom scan is required and the reported SAR from the area scan based 1-g SAR estimation procedures of KDB Publication 447498 is ≤ 1.4 W/kg, ≤ 8 mm, ≤ 7 mm and ≤ 5 mm zoom scan resolution may be applied, respectively, for 2 GHz to 3 GHz, 3 GHz to 4 GHz and 4 GHz to 6 GHz.

DASY is also able to perform repeated zoom scans if more than 1 peak is found during area scan. In this document, the evaluated peak 1g and 10g averaged SAR values are shown in the 2D-graphics in annex B. Test results relevant for the specified standard (see section 3) are shown in table form in section 7.

6.1.7 Spatial Peak SAR Evaluation

The spatial peak SAR - value for 1 and 10 g is evaluated after the Cube measurements have been done. The basis of the evaluation are the SAR values measured at the points of the fine cube grid consisting of all points in the three directions x, y and z. The algorithm that finds the maximal averaged volume is separated into three different stages.

- The data between the dipole center of the probe and the surface of the phantom are extrapolated. This data cannot be measured since the center of the dipole is 1 to 2.7 mm away from the tip of the probe and the distance between the surface and the lowest measuring point is about 1 mm (see probe calibration sheet). The extrapolated data from a cube measurement can be visualized by selecting 'Graph Evaluated'.
- The maximum interpolated value is searched with a straight-forward algorithm. Around this maximum the SAR - values averaged over the spatial volumes (1g or 10 g) are computed using the 3d-spline interpolation algorithm. If the volume cannot be evaluated (i.e., if a part of the grid was cut off by the boundary of the measurement area) the evaluation will be started on the corners of the bottom plane of the cube.
- All neighbouring volumes are evaluated until no neighbouring volume with a higher average value is found.

Extrapolation

The extrapolation is based on a least square algorithm [W. Gander, Computermathematik, p.168-180]. Through the points in the first 3 cm along the z-axis, polynomials of order four are calculated. These polynomials are then used to evaluate the points between the surface and the probe tip. The points, calculated from the surface, have a distance of 1 mm from each other.

Interpolation

The interpolation of the points is done with a 3d-Spline. The 3d-Spline is composed of three one-dimensional splines with the "Not a knot"-condition [W. Gander, Computermathematik, p.141-150] (x, y and z -direction) [Numerical Recipes in C, Second Edition, p.123ff].

Volume Averaging

At First the size of the cube is calculated. Then the volume is integrated with the trapezoidal algorithm. 8000 points (20x20x20) are interpolated to calculate the average.

Advanced Extrapolation

DASY uses the advanced extrapolation option which is able to compensate boundary effects on E-field probes.

6.1.8 Data Storage and Evaluation

Data Storage

The DASY software stores the acquired data from the data acquisition electronics as raw data (in microvolt readings from the probe sensors), together with all necessary software parameters for the data evaluation (probe calibration data, liquid parameters and device frequency and modulation data) in measurement files with the extension ".DA4", ".DA5x". The software evaluates the desired unit and format for output each time the data is visualized or exported. This allows verification of the complete software setup even after the measurement and allows correction of incorrect parameter settings. For example, if a measurement has been performed with a wrong crest factor parameter in the device setup, the parameter can be corrected afterwards and the data can be re-evaluated.

The measured data can be visualized or exported in different units or formats, depending on the selected probe type ([V/m], [A/m], [°C], [mW/g], [mW/cm²], [dBrel], etc.). Some of these units are not available in certain situations or show meaningless results, e.g., a SAR output in a lossless media will always be zero. Raw data can also be exported to perform the evaluation with other software packages.

Data Evaluation by SEMCAD

The SEMCAD software automatically executes the following procedures to calculate the field units from the microvolt readings at the probe connector. The parameters used in the evaluation are stored in the configuration modules of the software:

Probe parameters:	- Sensitivity	Norm _i , a _{i0} , a _{i1} , a _{i2}
	- Conversion factor	ConvF _i
	- Diode compression point	Dcpi
Device parameters:	- Frequency	f
	- Crest factor	cf
Media parameters:	- Conductivity	σ
	- Density	ρ

These parameters must be set correctly in the software. They can be found in the component documents or they can be imported into the software from the configuration files issued for the DASY components. In the direct measuring mode of the multimeter option, the parameters of the actual system setup are used. In the scan visualization and export modes, the parameters stored in the corresponding document files are used.

The first step of the evaluation is a linearization of the filtered input signal to account for the compression characteristics of the detector diode. The compensation depends on the input signal, the diode type and the DC-transmission factor from the diode to the evaluation electronics.

If the exciting field is pulsed, the crest factor of the signal must be known to correctly compensate for peak power. The formula for each channel can be given as:

$$V_i = U_i + U_i^2 \cdot cf/dcp_i$$

with V_i = compensated signal of channel i (i = x, y, z)
 U_i = input signal of channel i (i = x, y, z)
 cf = crest factor of exciting field (DASY parameter)
 dcp_i = diode compression point (DASY parameter)

From the compensated input signals the primary field data for each channel can be evaluated:

E-field probes: $E_i = (V_i / Norm_i \cdot ConvF)^{1/2}$

H-field probes: $H_i = (V_i)^{1/2} \cdot (a_{i0} + a_{i1}f + a_{i2}f^2)/f$

with V_i = compensated signal of channel i (i = x, y, z)
 $Norm_i$ = sensor sensitivity of channel i (i = x, y, z)
 [mV/(V/m)²] for E-field Probes
 $ConvF$ = sensitivity enhancement in solution
 a_{ij} = sensor sensitivity factors for H-field probes
 f = carrier frequency [GHz]
 E_i = electric field strength of channel i in V/m
 H_i = magnetic field strength of channel i in A/m

The RSS value of the field components gives the total field strength (Hermitian magnitude):

$$E_{tot} = (E_x^2 + E_y^2 + E_z^2)^{1/2}$$

The primary field data are used to calculate the derived field units.

$$SAR = (E_{tot}^2 \cdot \sigma) / (\rho \cdot 1000)$$

with SAR = local specific absorption rate in mW/g
 E_{tot} = total field strength in V/m
 σ = conductivity in [mho/m] or [Siemens/m]
 ρ = equivalent tissue density in g/cm³

Note that the density is normally set to 1 (or 1.06), to account for actual brain density rather than the density of the simulation liquid. The power flow density is calculated assuming the excitation field to be a free space field.

$$P_{pwe} = E_{tot}^2 / 3770 \quad \text{or} \quad P_{pwe} = H_{tot}^2 \cdot 37.7$$

with P_{pwe} = equivalent power density of a plane wave in mW/cm²
 E_{tot} = total electric field strength in V/m
 H_{tot} = total magnetic field strength in A/m

6.1.9 Tissue simulating liquids: dielectric properties

The following materials are used for producing the tissue-equivalent materials.

(Liquids used for tests described in section 7. are marked with ☒):

Ingredients (% of weight)	Frequency (MHz)								
	<input checked="" type="checkbox"/> 450	<input type="checkbox"/> 750	<input type="checkbox"/> 835	<input type="checkbox"/> 900	<input type="checkbox"/> 1450	<input type="checkbox"/> 1750	<input type="checkbox"/> 1900	<input type="checkbox"/> 2450	<input type="checkbox"/> 5000
frequency band									
Water	51.16	51.7	52.4	56.0	71.40	71.45	71.56	71.65	64 - 78
Salt (NaCl)	1.49	0.9	1.40	0.76	0.55	0.5	0.39	0.3	2 - 3
Sugar	46.78	47.2	45.0	41.76	0.0	0.0	0.0	0.0	0.0
HEC	0.52	0.0	1.0	1.21	0.0	0.0	0.0	0.0	0.0
Bactericide	0.05	0.1	0.1	0.27	0.1	0.1	0.1	0.1	0.0
Tween 20	0.0	0.0	0.0	0.0	27.95	27.95	27.95	27.95	0.0
Emulsifiers	0.0	0.0	0.0	0.0	0.0	0.0	0.0	0.0	9 - 15
Mineral Oil	0.0	0.0	0.0	0.0	0.0	0.0	0.0	0.0	11 - 18

Table 2: Body tissue dielectric properties

Salt: 99+% Pure Sodium Chloride

Water: De-ionized, 16MΩ+ resistivity

Sugar: 98+% Pure Sucrose

HEC: Hydroxyethyl Cellulose

Tween 20: Polyoxyethylene (20) sorbitan monolaurate

6.1.10 Tissue simulating liquids: parameters

Liquid MSL	Freq. (MHz)	Target body tissue		Measurement body tissue					Measurement date
		Permittivity	Conductivity (S/m)	Permittivity	Dev.	Conductivity		Dev.	
						ε"	(S/m)		
450	450	56.70	0.94	57.0	0.5%	35.7	0.89	-4.9%	2019-01-04
	514	56.45	0.94	56.0	-0.7%	33.1	0.95	0.2%	
	558	56.28	0.95	55.5	-1.3%	31.8	0.99	4.1%	
	583	56.18	0.95	55.3	-1.6%	31.4	1.02	7.2%	
	600	56.12	0.95	55.1	-1.9%	31.1	1.04	9.1%	
	608	56.08	0.95	55.0	-1.9%	30.9	1.05	9.9%	

Table 3: Parameter of the body tissue simulating liquid

Note: The dielectric properties have been measured using the contact probe method at 22°C.

6.1.11 Measurement uncertainty evaluation for SAR test

DASY5 Uncertainty Budget									
According to IEEE 1528/2003 and IEC 62209-1 for the 300 MHz - 3 GHz range									
Source of uncertainty	uncertainty Value ± %	Probability Distribution	Divisor	c _i (1g)	c _i (10g)	Standard Uncertainty		v _i ² or v _{eff}	
						± %, (1g)	± %, (10g)		
Measurement System									
Probe calibration	± 6.0 %	Normal	1	1	1	± 6.0 %	± 6.0 %	∞	
Axial isotropy	± 4.7 %	Rectangular	√ 3	0.7	0.7	± 1.9 %	± 1.9 %	∞	
Hemispherical isotropy	± 9.6 %	Rectangular	√ 3	0.7	0.7	± 3.9 %	± 3.9 %	∞	
Boundary effects	± 1.0 %	Rectangular	√ 3	1	1	± 0.6 %	± 0.6 %	∞	
Probe linearity	± 4.7 %	Rectangular	√ 3	1	1	± 2.7 %	± 2.7 %	∞	
System detection limits	± 1.0 %	Rectangular	√ 3	1	1	± 0.6 %	± 0.6 %	∞	
Readout electronics	± 0.3 %	Normal	1	1	1	± 0.3 %	± 0.3 %	∞	
Response time	± 0.8 %	Rectangular	√ 3	1	1	± 0.5 %	± 0.5 %	∞	
Integration time	± 2.6 %	Rectangular	√ 3	1	1	± 1.5 %	± 1.5 %	∞	
RF ambient noise	± 3.0 %	Rectangular	√ 3	1	1	± 1.7 %	± 1.7 %	∞	
RF ambient reflections	± 3.0 %	Rectangular	√ 3	1	1	± 1.7 %	± 1.7 %	∞	
Probe positioner	± 0.4 %	Rectangular	√ 3	1	1	± 0.2 %	± 0.2 %	∞	
Probe positioning	± 2.9 %	Rectangular	√ 3	1	1	± 1.7 %	± 1.7 %	∞	
Max.SAR evaluation	± 1.0 %	Rectangular	√ 3	1	1	± 0.6 %	± 0.6 %	∞	
Test Sample Related									
Device positioning	± 2.9 %	Normal	1	1	1	± 2.9 %	± 2.9 %	145	
Device holder uncertainty	± 3.6 %	Normal	1	1	1	± 3.6 %	± 3.6 %	5	
Power drift	± 5.0 %	Rectangular	√ 3	1	1	± 2.9 %	± 2.9 %	∞	
Phantom and Set-up									
Phantom uncertainty	± 4.0 %	Rectangular	√ 3	1	1	± 2.3 %	± 2.3 %	∞	
Liquid conductivity (target)	± 10.0 %	Rectangular	√ 3	0.64	0.43	± 3.7 %	± 2.5 %	∞	
Liquid conductivity (meas.)	± 10.0 %	Rectangular	√ 3	0.64	0.43	± 3.7 %	± 2.5 %	∞	
Liquid permittivity (target)	± 5.0 %	Rectangular	√ 3	0.6	0.49	± 1.7 %	± 1.4 %	∞	
Liquid permittivity (meas.)	± 5.0 %	Rectangular	√ 3	0.6	0.49	± 1.7 %	± 1.4 %	∞	
Combined Std.						± 11.9 %	± 11.2 %	387	
Expanded Std.						± 23.9 %	± 22.4 %		

Table 4: Measurement uncertainties

Worst-Case uncertainty budget for DASY5 assessed according to IEEE 1528/2003.

The budget is valid for 2G and 3G communication signals and frequency range 300MHz - 3 GHz.

For these conditions it represents a worst-case analysis. For specific tests and configurations, the uncertainty could be considerable smaller.

Relative DASY5 Uncertainty Budget for SAR Tests									
According to IEEE 1528/2013 and IEC62209/2011 for the 0.3 - 3GHz range									
Error Description	Uncertainty Value ± %	Probability Distribution	Divisor	c _i (1g)	c _i (10g)	Standard Uncertainty		v _i ² or v _{eff}	
						± %, (1g)	± %, (10g)		
Measurement System									
Probe calibration	± 6.0 %	Normal	1	1	1	± 6.0 %	± 6.0 %	∞	
Axial isotropy	± 4.7 %	Rectangular	√3	0.7	0.7	± 1.9 %	± 1.9 %	∞	
Hemispherical isotropy	± 9.6 %	Rectangular	√3	0.7	0.7	± 3.9 %	± 3.9 %	∞	
Boundary effects	± 1.0 %	Rectangular	√3	1	1	± 0.6 %	± 0.6 %	∞	
Probe linearity	± 4.7 %	Rectangular	√3	1	1	± 2.7 %	± 2.7 %	∞	
System detection limits	± 1.0 %	Rectangular	√3	1	1	± 0.6 %	± 0.6 %	∞	
Modulation Response	± 2.4 %	Rectangular	√3	1	1	± 1.4 %	± 1.4 %	∞	
Readout electronics	± 0.3 %	Normal	1	1	1	± 0.3 %	± 0.3 %	∞	
Response time	± 0.8 %	Rectangular	√3	1	1	± 0.5 %	± 0.5 %	∞	
Integration time	± 2.6 %	Rectangular	√3	1	1	± 1.5 %	± 1.5 %	∞	
RF ambient noise	± 3.0 %	Rectangular	√3	1	1	± 1.7 %	± 1.7 %	∞	
RF ambient reflections	± 3.0 %	Rectangular	√3	1	1	± 1.7 %	± 1.7 %	∞	
Probe positioner	± 0.4 %	Rectangular	√3	1	1	± 0.2 %	± 0.2 %	∞	
Probe positioning	± 2.9 %	Rectangular	√3	1	1	± 1.7 %	± 1.7 %	∞	
Max. SAR evaluation	± 2.0 %	Rectangular	√3	1	1	± 1.2 %	± 1.2 %	∞	
Test Sample Related									
Device positioning	± 2.9 %	Normal	1	1	1	± 2.9 %	± 2.9 %	145	
Device holder uncertainty	± 3.6 %	Normal	1	1	1	± 3.6 %	± 3.6 %	5	
Power drift	± 5.0 %	Rectangular	√3	1	1	± 2.9 %	± 2.9 %	∞	
Phantom and Set-up									
Phantom uncertainty	± 6.1 %	Rectangular	√3	1	1	± 3.5 %	± 3.5 %	∞	
SAR correction	± 1.9 %	Rectangular	√3	1	0.84	± 1.1 %	± 0.9 %	∞	
Liquid conductivity (meas.)	± 10.0 %	Rectangular	√3	0.78	0.71	± 4.5 %	± 4.1 %	∞	
Liquid permittivity (meas.)	± 5.0 %	Rectangular	√3	0.26	0.26	± 0.8 %	± 0.8 %	∞	
Temp. Unc. - Conductivity	± 3.4 %	Rectangular	√3	0.78	0.71	± 1.5 %	± 1.4 %	∞	
Temp. Unc. - Permittivity	± 0.4 %	Rectangular	√3	0.23	0.26	± 0.1 %	± 0.1 %	∞	
Combined Uncertainty						± 12.0 %	± 11.8 %	330	
Expanded Std. Uncertainty						± 24.0 %	± 23.6 %		

Table 5: Measurement uncertainties

Worst-Case uncertainty budget for DASY5 assessed according to IEEE 1528/2013 and IEC 62209-1/2011 standards. The budget is valid for the frequency range 300MHz -3 GHz and represents a worst-case analysis. For specific tests and configurations, the uncertainty could be considerable smaller.

DASY5 Uncertainty Budget									
According to IEC 62209-2/2010 for the 300 MHz - 6 GHz range									
Source of uncertainty	Uncertainty Value	Probability Distribution	Divisor	c _i (1g)	c _i (10g)	Standard Uncertainty		v _i ² or v _{eff}	
						± %, (1g)	± %, (10g)		
Measurement System									
Probe calibration	± 6.6 %	Normal	1	1	1	± 6.6 %	± 6.6 %	∞	
Axial isotropy	± 4.7 %	Rectangular	√ 3	0.7	0.7	± 1.9 %	± 1.9 %	∞	
Hemispherical isotropy	± 9.6 %	Rectangular	√ 3	0.7	0.7	± 3.9 %	± 3.9 %	∞	
Boundary effects	± 2.0 %	Rectangular	√ 3	1	1	± 1.2 %	± 1.2 %	∞	
Probe linearity	± 4.7 %	Rectangular	√ 3	1	1	± 2.7 %	± 2.7 %	∞	
System detection limits	± 1.0 %	Rectangular	√ 3	1	1	± 0.6 %	± 0.6 %	∞	
Modulation Response	± 2.4 %	Rectangular	√ 3	1	1	± 1.4 %	± 1.4 %	∞	
Readout electronics	± 0.3 %	Normal	1	1	1	± 0.3 %	± 0.3 %	∞	
Response time	± 0.8 %	Rectangular	√ 3	1	1	± 0.5 %	± 0.5 %	∞	
Integration time	± 2.6 %	Rectangular	√ 3	1	1	± 1.5 %	± 1.5 %	∞	
RF ambient noise	± 3.0 %	Rectangular	√ 3	1	1	± 1.7 %	± 1.7 %	∞	
RF ambient reflections	± 3.0 %	Rectangular	√ 3	1	1	± 1.7 %	± 1.7 %	∞	
Probe positioner	± 0.8 %	Rectangular	√ 3	1	1	± 0.5 %	± 0.5 %	∞	
Probe positioning	± 6.7 %	Rectangular	√ 3	1	1	± 3.9 %	± 3.9 %	∞	
Post-processing	± 4.0 %	Rectangular	√ 3	1	1	± 2.3 %	± 2.3 %	∞	
Test Sample Related									
Device positioning	± 2.9 %	Normal	1	1	1	± 2.9 %	± 2.9 %	145	
Device holder uncertainty	± 3.6 %	Normal	1	1	1	± 3.6 %	± 3.6 %	5	
Power drift	± 5.0 %	Rectangular	√ 3	1	1	± 2.9 %	± 2.9 %	∞	
Phantom and Set-up									
Phantom uncertainty	± 7.9 %	Rectangular	√ 3	1	1	± 4.6 %	± 4.6 %	∞	
SAR correction	± 1.9 %	Rectangular	√ 3	1	0.84	± 1.1 %	± 0.9 %	∞	
Liquid conductivity (meas.)	± 10.0 %	Rectangular	√ 3	0.78	0.71	± 4.5 %	± 4.1 %	∞	
Liquid permittivity (meas.)	± 5.0 %	Rectangular	√ 3	0.26	0.26	± 0.8 %	± 0.8 %	∞	
Temp. Unc. - Conductivity	± 3.4 %	Rectangular	√ 3	0.78	0.71	± 1.5 %	± 1.4 %	∞	
Temp. Unc. - Permittivity	± 0.4 %	Rectangular	√ 3	0.23	0.26	± 0.1 %	± 0.1 %	∞	
Combined Uncertainty						± 13.3 %	± 13.1 %	330	
Expanded Std. Uncertainty						± 26.6 %	± 26.2 %		

Table 6: Measurement uncertainties.

Worst-Case uncertainty budget for DASY5 assessed according to IEC 62209-2/2010 standard. The budget is valid for the frequency range 300MHz - 6 GHz and represents a worst-case analysis. For specific tests and configurations, the uncertainty could be considerable smaller.

6.1.12 Measurement uncertainty evaluation for System Check

Uncertainty of a System Performance Check with DASY5 System for the 0.3 - 3 GHz range									
Source of uncertainty	Uncertainty Value	Probability Distribution	Divisor	c_i	c_i	Standard Uncertainty		v_i^2 or v_{eff}	
				(1g)	(10g)	± %, (1g)	± %, (10g)		
Measurement System									
Probe calibration	± 6.0 %	Normal	1	1	1	± 6.0 %	± 6.0 %	∞	
Axial isotropy	± 4.7 %	Rectangular	√ 3	0.7	0.7	± 1.9 %	± 1.9 %	∞	
Hemispherical isotropy	± 0.0 %	Rectangular	√ 3	0.7	0.7	± 0.0 %	± 0.0 %	∞	
Boundary effects	± 1.0 %	Rectangular	√ 3	1	1	± 0.6 %	± 0.6 %	∞	
Probe linearity	± 4.7 %	Rectangular	√ 3	1	1	± 2.7 %	± 2.7 %	∞	
System detection limits	± 1.0 %	Rectangular	√ 3	1	1	± 0.6 %	± 0.6 %	∞	
Readout electronics	± 0.3 %	Normal	1	1	1	± 0.3 %	± 0.3 %	∞	
Response time	± 0.0 %	Rectangular	√ 3	1	1	± 0.0 %	± 0.0 %	∞	
Integration time	± 0.0 %	Rectangular	√ 3	1	1	± 0.0 %	± 0.0 %	∞	
RF ambient conditions	± 3.0 %	Rectangular	√ 3	1	1	± 1.7 %	± 1.7 %	∞	
Probe positioner	± 0.4 %	Rectangular	√ 3	1	1	± 0.2 %	± 0.2 %	∞	
Probe positioning	± 2.9 %	Rectangular	√ 3	1	1	± 1.7 %	± 1.7 %	∞	
Max. SAR evaluation	± 1.0 %	Rectangular	√ 3	1	1	± 0.6 %	± 0.6 %	∞	
Test Sample Related									
Dev. of experimental dipole	± 0.0 %	Rectangular	√ 3	1	1	± 0.0 %	± 0.0 %	∞	
Source to liquid distance	± 2.0 %	Rectangular	√ 3	1	1	± 1.2 %	± 1.2 %	∞	
Power drift	± 3.4 %	Rectangular	√ 3	1	1	± 2.0 %	± 2.0 %	∞	
Phantom and Set-up									
Phantom uncertainty	± 4.0 %	Rectangular	√ 3	1	1	± 2.3 %	± 2.3 %	∞	
SAR correction	± 1.9 %	Rectangular	√ 3	1	0.84	± 1.1 %	± 0.9 %	∞	
Liquid conductivity (meas.)	± 10.0 %	Normal	1	0.78	0.71	± 7.8 %	± 7.1 %	∞	
Liquid permittivity (meas.)	± 5.0 %	Normal	1	0.26	0.26	± 1.3 %	± 1.3 %	∞	
Temp. unc. - Conductivity	± 1.7 %	Rectangular	√ 3	0.78	0.71	± 0.8 %	± 0.7 %	∞	
Temp. unc. - Permittivity	± 0.3 %	Rectangular	√ 3	0.23	0.26	± 0.0 %	± 0.0 %	∞	
Combined Uncertainty						± 11.3 %	± 10.9 %	330	
Expanded Std. Uncertainty						± 22.7 %	± 21.7 %		

Table 7: Measurement uncertainties of the System Check with DASY5 (0.3-3GHz)

Note: Worst case probe calibration uncertainty has been applied for all probes used during the measurements.

6.1.13 System check

The system check is performed for verifying the accuracy of the complete measurement system and performance of the software. The system check is performed with tissue equivalent material according to IEEE 1528. The following table shows system check results for all frequency bands and tissue liquids used during the tests (plot(s) see annex A).

System performance check (1000 mW)									
System validation Kit	Probe	Frequency	Target SAR _{1g} /mW/g (+/- 10%)	Target SAR _{10g} /mW/g (+/- 10%)	Measured SAR _{1g} / mW/g	SAR _{1g} dev.	Measured SAR _{10g} / mW/g	SAR _{10g} dev.	Measured date
D450V3 S/N: 1060	ES3DV3 S/N: 3320	450 MHz MSL	4.63	3.11	4.36	-5.8%	2.97	-4.5%	2019-01-04
D600V3 S/N: 1015	ES3DV3 S/N: 3320	600 MHz MSL	6.56	4.35	6.68	1.8%	4.37	0.5%	2019-01-04

Table 8: Results system check

6.1.14 System check procedure

The system check is performed by using a validation dipole which is positioned parallel to the planar part of the SAM phantom at the reference point. The distance of the dipole to the SAM phantom is determined by a plexiglass spacer. The dipole is connected to the signal source consisting of signal generator and amplifier via a directional coupler, N-connector cable and adaption to SMA. It is fed with a power of 1000 mW for frequencies below 2 GHz or 100 mW for frequencies above 2 GHz. To adjust this power a power meter is used. The power sensor is connected to the cable before the system check to measure the power at this point and do adjustments at the signal generator. At the outputs of the directional coupler both return loss as well as forward power are controlled during the validation to make sure that emitted power at the dipole is kept constant. This can also be checked by the power drift measurement after the test (result on plot).

System check results have to be equal or near the values determined during dipole calibration (target SAR in table above) with the relevant liquids and test system.

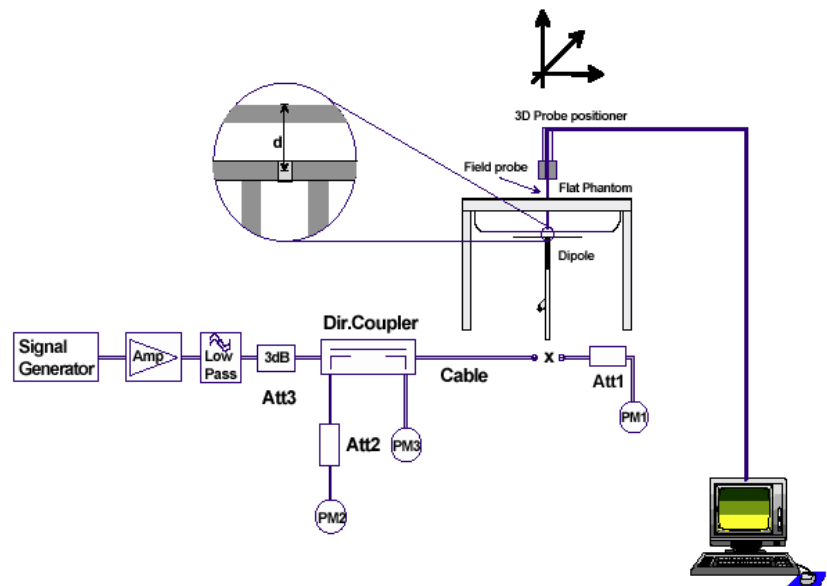

6.1.15 System validation

The system validation is performed in a similar way as a system check. It needs to be performed once a SAR measurement system has been established and allows an evaluation of the system accuracy with all components used together with the specified system. It has to be repeated at least once a year or when new system components are used (DAE, probe, phantom, dipole, liquid type).

In addition to the procedure used during system check a system validation also includes checks of probe isotropy, probe modulation factor and RF signal.

The following table lists the system validations relevant for this test report:

Frequency (MHz)	DASY SW	Dipole Type /SN	Probe Type / SN	Calibrated signal type(s)	DAE unit Type / SN	body validation
450	V52.8.7	D450V3 / 1060	ES3DV3 / 3320	CW	DAE3 / 413	2018-01-30
600	V52.8.7	D600V3 / 1015	ES3DV3 / 3320	CW	DAE3 / 413	2018-01-31

7 Detailed Test Results

7.1 Conducted power measurements

Freq. (MHz)	cond. P _{max} (dBm)	
	declared *	measured
470-558MHz		
470.1	20.5	18.9
514.0	20.5	20.1
558.0	20.5	19.8
558-608MHz		
558.0	21.0	19.1
583.0	21.0	20.9
607.9	21.0	20.8

Table 9: Test results conducted power measurements

*) Maximum declared by manufacturer

7.2 SAR test results

7.2.1 General description of test procedures

- Test positions as described in the tables above are in accordance with the specified test standard.
- Tests were performed in the high output power.
- According to IEEE 1528 the SAR test shall be performed at middle channel. Testing of top and bottom channel is optional.
- IEEE 1528-2013 requires the middle channel to be tested first. This generally applies to wireless devices that are designed to operate in technologies with tight tolerances for maximum output power variations across channels in the band. When the maximum output power variation across the required test channels is > ½ dB, instead of the middle channel, the highest output power channel must be used.

7.2.2 Results overview

measured / extrapolated SAR numbers										
Freq. (MHz)	Position	cond. P _{max} (dBm)		SAR _{1g} (W/kg)		SAR _{10g} (W/kg)		power drift (dB)	liquid (°C)	dist. (mm)
		decl.*	meas.	meas.	extrap.	meas.	extrap.			
AW+ 470-558MHz										
514.0	front	20.5	20.1	0.574	0.629	0.275	0.302	-0.05	21.5	0
514.0	left	20.5	20.1	0.591	0.648	0.316	0.346	-0.02	21.5	0
470.1	rear	20.5	18.9	0.506	0.731	0.247	0.357	-0.18	21.5	0
514.0	rear	20.5	20.1	0.745	0.817	0.379	0.416	-0.01	21.5	0
558.0	rear	20.5	19.8	0.270	0.317	0.143	0.168	-0.11	21.5	0
514.0	right	20.5	20.1	0.613	0.672	0.332	0.364	0.00	21.5	0
514.0	bottom	20.5	20.1	0.070	0.077	0.024	0.026	-0.06	21.5	0
GW1 P 550-608MHz										
583.0	front	21.0	20.9	0.487	0.498	0.257	0.263	-0.04	21.5	0
583.0	left	21.0	20.9	0.517	0.529	0.295	0.302	0.01	21.5	0
558.0	rear	21.0	19.1	0.822	1.273	0.436	0.675	-0.15	21.5	0
583.0	rear	21.0	20.9	0.641	0.656	0.353	0.361	0.02	21.5	0
607.9	rear	21.0	20.8	0.330	0.346	0.184	0.193	-0.01	21.5	0
583.0	right	21.0	20.9	0.542	0.555	0.392	0.401	-0.02	21.5	0
583.0	bottom	21.0	20.9	0.185	0.189	0.061	0.062	-0.01	21.5	0

Table 10: Test results body worn for SK 2000 Aw+ / Gw1

* - maximum possible output power declared by manufacturer

8 Test equipment and ancillaries used for tests

To simplify the identification of the test equipment and/or ancillaries which were used, the reporting of the relevant test cases only refer to the test item number as specified in the table below.

Equipment	Type	Manufacturer	Serial No.	Last Calibration	Frequency (months)
Dosimetric E-Field Probe	ES3DV3	Schmid & Partner Engineering AG	3320	January 15, 2018	12
450 MHz System Validation Dipole	D450V3	Schmid & Partner Engineering AG	1060	January 11, 2017	36
600 MHz System Validation Dipole	D600V3	Schmid & Partner Engineering AG	1015	January 12, 2018	36
Data acquisition electronics	DAE3V1	Schmid & Partner Engineering AG	413	January 10, 2018	12
Software	DASY52 52.8.7	Schmid & Partner Engineering AG	---	N/A	--
Triple Modular Flat Phantom V5.1	QD 000 P51 C	Schmid & Partner Engineering AG	1154	N/A	--
Universal Radio Communication Tester	CMU 200	Rohde & Schwarz	106826	December 17, 2018	24
Network Analyser 300 kHz to 6 GHz	8753ES	Agilent Technologies)*	US39174436	December 14, 2017	24
Dielectric Probe Kit	85070C	Hewlett Packard	US99360146	N/A	12
Signal Generator	8665A	Hewlett Packard	2833A00112	December 14, 2017	24
Amplifier	25S1G4 (25 Watt)	Amplifier Reasearch	20452	N/A	--
Power Meter	NRP	Rohde & Schwarz	101367	December 11, 2018	24
Power Meter Sensor	NRP Z22	Rohde & Schwarz	100227	December 11, 2018	12
Power Meter Sensor	NRP Z22	Rohde & Schwarz	100234	December 11, 2018	12
Directional Coupler	778D	Hewlett Packard	19171	December 10, 2017	12

)* : Network analyzer probe calibration against air, distilled water and a shorting block performed before measuring liquid parameters.

9 Observations

No observations exceeding those reported with the single test cases have been made.

Annex A: System performance check

Date/Time: 04.01.2019 16:54:40

SystemPerformanceCheck-D450 MSL 2019-01-04
DUT: Dipole 450 MHz; Type: D450V2; Serial: 1060

Communication System: UID 0, CW (0); Communication System Band: D450 (450.0 MHz); Frequency: 450 MHz; Communication System PAR: 0 dB; PMF: 1

 Medium parameters used: $f = 450$ MHz; $\sigma = 0.894$ S/m; $\epsilon_r = 56.961$; $\rho = 1000$ kg/m³

Phantom section: Center Section

Measurement Standard: DASY5

DASY5 Configuration:

- Probe: ES3DV3 - SN3320; ConvF(7.15, 7.15, 7.15); Calibrated: 15.01.2018;
- Sensor-Surface: 3mm (Mechanical Surface Detection), $z = 2.0, 27.0$
- Electronics: DAE3 Sn413; Calibrated: 10.01.2018
- Phantom: Triple Flat Phantom 5.1C; Type: QD 000 P51 CA; Serial: 1154
- DASY52 52.8.7(1137); SEMCAD X 14.6.10(7164)

MSL450/d=15mm, Pin=100mW/Area Scan (41x61x1): Interpolated grid: $dx=1.500$ mm, $dy=1.500$ mm

Maximum value of SAR (interpolated) = 0.504 W/kg

MSL450/d=15mm, Pin=100mW/Zoom Scan (5x5x7)/Cube 0: Measurement grid:
 $dx=7.5$ mm, $dy=7.5$ mm, $dz=5$ mm

Reference Value = 23.930 V/m; Power Drift = -0.09 dB

Peak SAR (extrapolated) = 0.688 W/kg

SAR(1 g) = 0.436 W/kg; SAR(10 g) = 0.297 W/kg

Maximum value of SAR (measured) = 0.505 W/kg

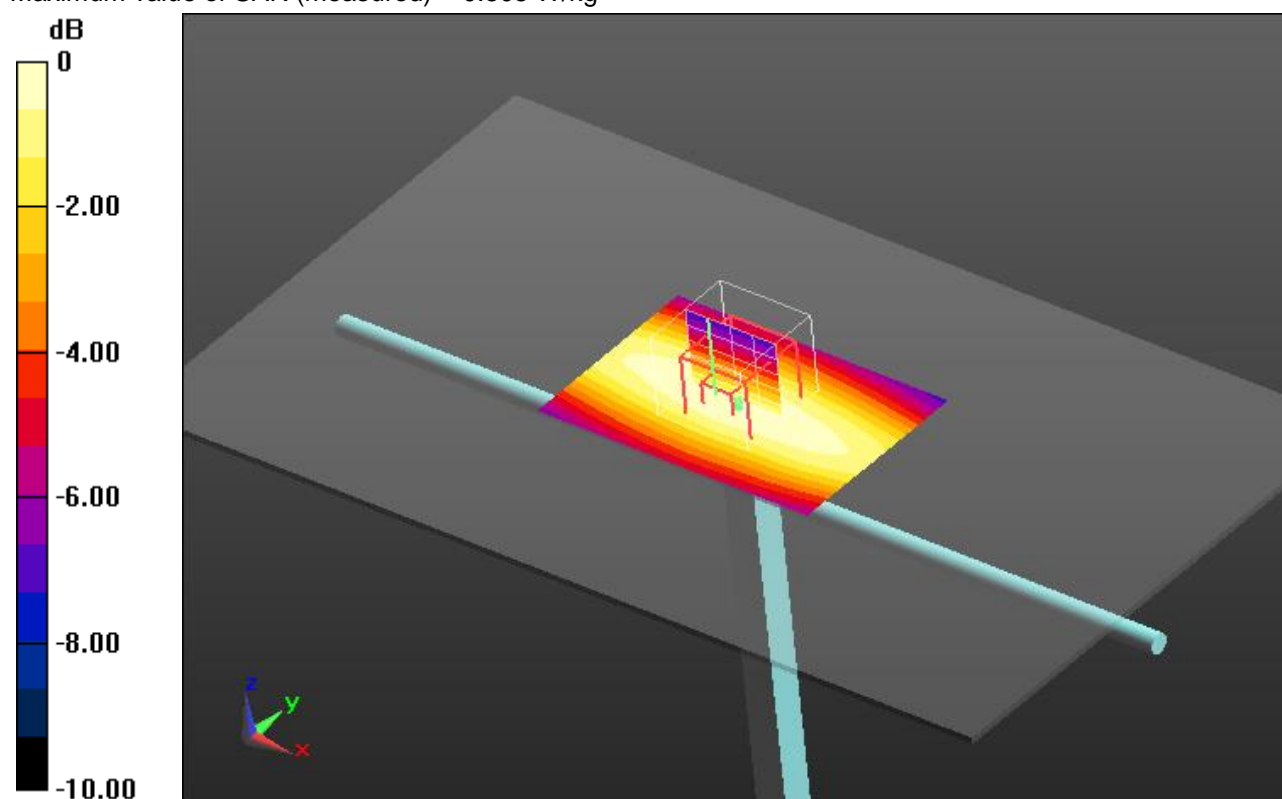

0 dB = 0.505 W/kg = -2.97 dBW/kg

Additional information:

ambient temperature: 23.6°C; liquid temperature: 21.5°C

SystemPerformanceCheck-D600 MSL 2019-01-04

DUT: Dipole 600 MHz; Type: D600V3; Serial: 1015

Communication System: UID 0, CW (0); Communication System Band: D600 (600.0 MHz); Frequency: 600 MHz; Communication System PAR: 0 dB; PMF: 1

Medium parameters used: $f = 600$ MHz; $\sigma = 1.038$ S/m; $\epsilon_r = 55.075$; $\rho = 1000$ kg/m³

Phantom section: Center Section

Measurement Standard: DASY5

DASY5 Configuration:

- Probe: ES3DV3 - SN3320; ConvF(6.77, 6.77, 6.77); Calibrated: 15.01.2018;
- Sensor-Surface: 3mm (Mechanical Surface Detection (Locations From Previous Scan Used)), Sensor-Surface: 3mm (Mechanical Surface Detection), $z = 2.0, 27.0$
- Electronics: DAE3 Sn413; Calibrated: 10.01.2018
- Phantom: Triple Flat Phantom 5.1C; Type: QD 000 P51 CA; Serial: 1154
- DASY52 52.8.7(1137); SEMCAD X 14.6.10(7164)

MSL450/d=15mm, Pin=100mW/Area Scan (41x61x1): Interpolated grid: $dx=1.500$ mm, $dy=1.500$ mm

Maximum value of SAR (interpolated) = 0.806 W/kg

MSL450/d=15mm, Pin=100mW/Zoom Scan (6x5x7)/Cube 0: Measurement grid:

$dx=7.5$ mm, $dy=7.5$ mm, $dz=5$ mm

Reference Value = 28.050 V/m; Power Drift = -0.13 dB

Peak SAR (extrapolated) = 1.08 W/kg

SAR(1 g) = 0.668 W/kg; SAR(10 g) = 0.437 W/kg

Maximum value of SAR (measured) = 0.783 W/kg

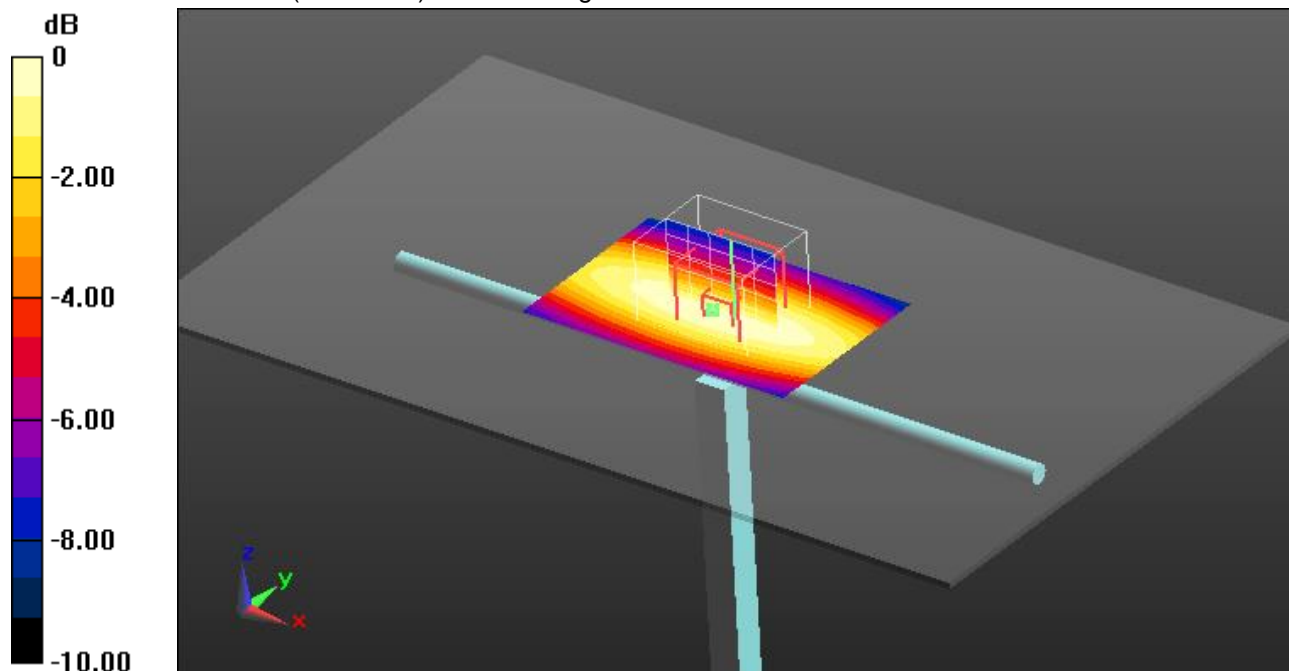

0 dB = 0.783 W/kg = -1.06 dBW/kg

Additional information:

position or distance of DUT to the phantom: 0 mm

ambient temperature: 23.6°C; liquid temperature: 21.5°C

Annex B: DASY5 measurement results

SAR plots for the highest measured SAR in each exposure configuration, wireless mode and frequency band combination according to FCC KDB 865664 D02

Date/Time: 04.01.2019 10:32:44

FCC_IEC62209-2_SKM2000

DUT: Sennheiser; Type: SKM 2000 AW+; Serial: 1064289102

Communication System: UID 0, FM (0); Communication System Band: FM-539; Frequency: 514 MHz;

Communication System PAR: 0 dB; PMF: 1.12202e-005

Medium parameters used: $f = 514$ MHz; $\sigma = 0.947$ S/m; $\epsilon_r = 56.046$; $\rho = 1000$ kg/m³

Phantom section: Center Section

Measurement Standard: DASY5

DASY5 Configuration:

- Probe: ES3DV3 - SN3320; ConvF(7.15, 7.15, 7.15); Calibrated: 15.01.2018;
- Sensor-Surface: 3mm (Mechanical Surface Detection (Locations From Previous Scan Used)), Sensor-Surface: 3mm (Mechanical Surface Detection), $z = -8.0, 27.0$
- Electronics: DAE3 Sn413; Calibrated: 10.01.2018
- Phantom: Triple Flat Phantom 5.1C; Type: QD 000 P51 CA; Serial: 1154
- DASY52 52.8.7(1137); SEMCAD X 14.6.10(7164)

AW+ 470-558MHz/Rear position - 514 MHz/Area Scan (61x191x1): Interpolated
 grid: $dx=1.500$ mm, $dy=1.500$ mm

Maximum value of SAR (interpolated) = 0.817 W/kg

AW+ 470-558MHz/Rear position - 514 MHz/Zoom Scan (5x5x7)/Cube 0:

Measurement grid: $dx=7.5$ mm, $dy=7.5$ mm, $dz=5$ mm

Reference Value = 27.250 V/m; Power Drift = -0.01 dB

Peak SAR (extrapolated) = 1.90 W/kg

SAR(1 g) = 0.745 W/kg; SAR(10 g) = 0.379 W/kg

Maximum value of SAR (measured) = 0.982 W/kg

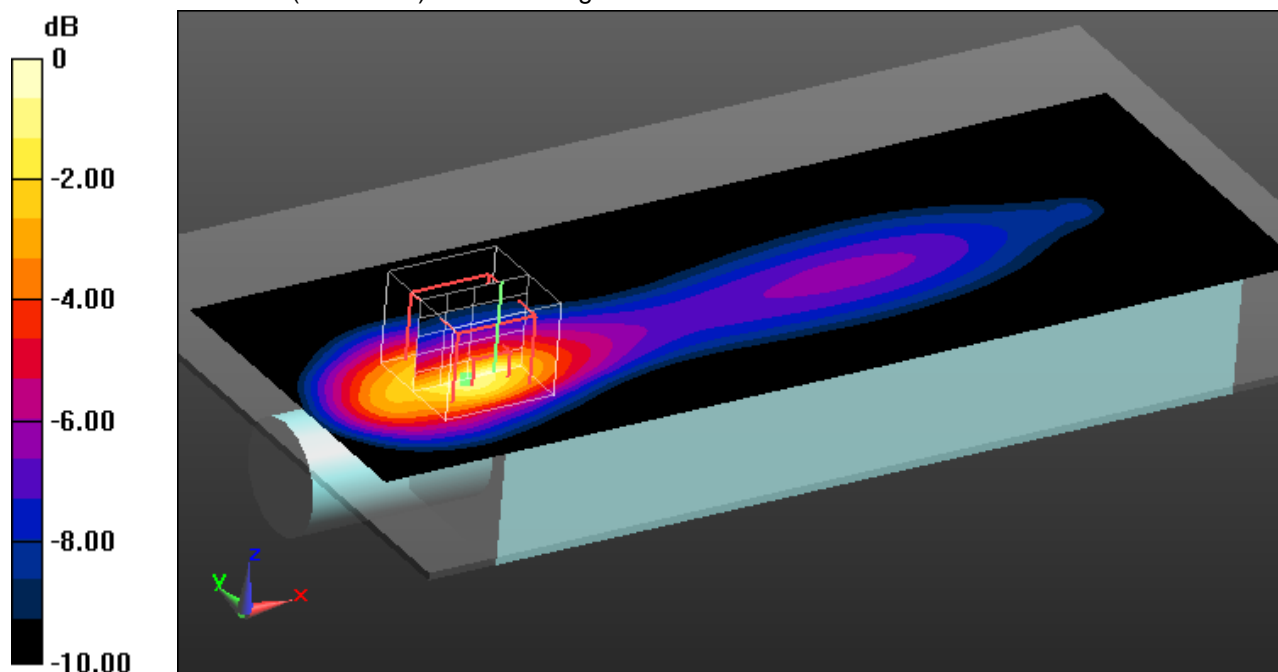

0 dB = 0.982 W/kg = -0.08 dBW/kg

Additional information:

position or distance of DUT to the phantom: 0 mm

ambient temperature: 23.6°C; liquid temperature: 21.5°C

FCC_IEC62209-2_SKM2000

DUT: Sennheiser; Type: SKM 2000 GW1 P; Serial: 1084289123

Communication System: UID 0, FM (0); Communication System Band: FM-583; Frequency: 558 MHz;

Communication System PAR: 0 dB; PMF: 1.12202e-005

Medium parameters used: $f = 558$ MHz; $\sigma = 0.987$ S/m; $\epsilon_r = 55.52$; $\rho = 1000$ kg/m³

Phantom section: Center Section

Measurement Standard: DASY5

DASY5 Configuration:

- Probe: ES3DV3 - SN3320; ConvF(6.77, 6.77, 6.77); Calibrated: 15.01.2018;
- Sensor-Surface: 3mm (Mechanical Surface Detection (Locations From Previous Scan Used)), Sensor-Surface: 3mm (Mechanical Surface Detection), $z = -8.0, 27.0$
- Electronics: DAE3 Sn413; Calibrated: 10.01.2018
- Phantom: Triple Flat Phantom 5.1C; Type: QD 000 P51 CA; Serial: 1154
- DASY52 52.8.7(1137); SEMCAD X 14.6.10(7164)

GW1 P 558-608MHz/Rear position - 558 MHz/Area Scan (61x191x1):

Interpolated grid: $dx=1.500$ mm, $dy=1.500$ mm

Maximum value of SAR (interpolated) = 0.967 W/kg

GW1 P 558-608MHz/Rear position - 558 MHz/Zoom Scan (6x6x7)/Cube 0:

Measurement grid: $dx=7.5$ mm, $dy=7.5$ mm, $dz=5$ mm

Reference Value = 23.403 V/m; Power Drift = -0.15 dB

Peak SAR (extrapolated) = 2.00 W/kg

SAR(1 g) = 0.822 W/kg; SAR(10 g) = 0.436 W/kg

Maximum value of SAR (measured) = 1.13 W/kg

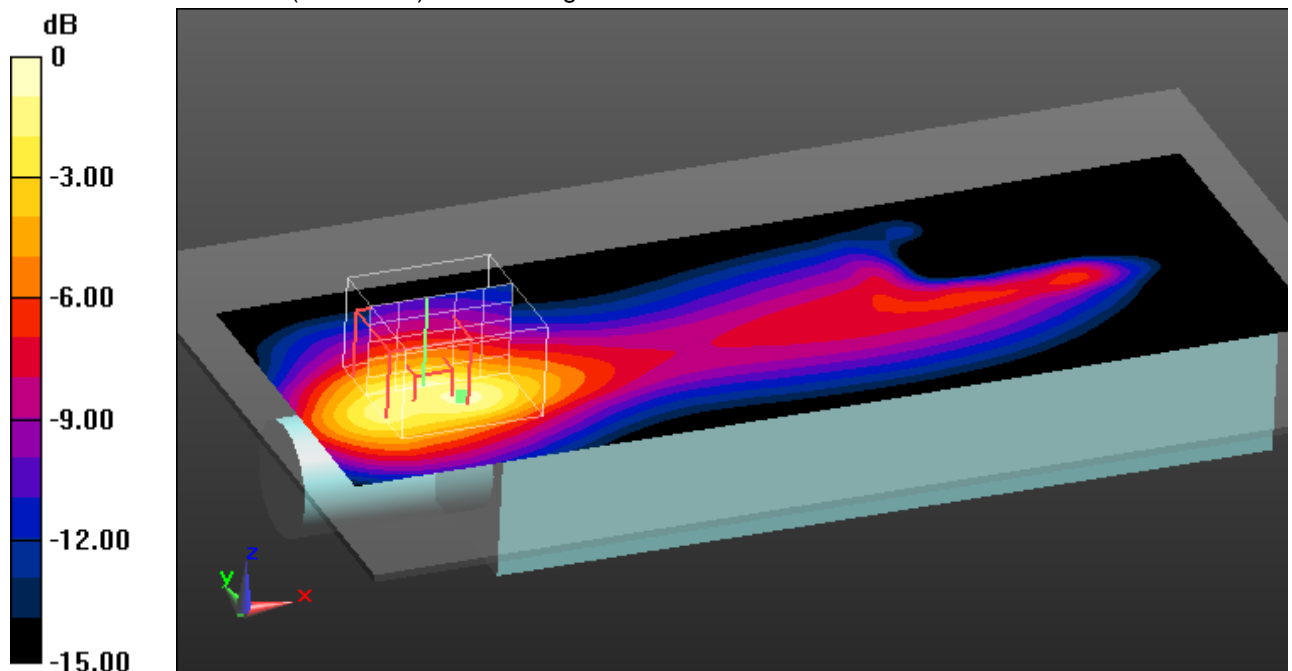

0 dB = 1.13 W/kg = 0.53 dBW/kg

Additional information:

position or distance of DUT to the phantom: 0 mm

ambient temperature: 23.6°C; liquid temperature: 21.5°C

Annex B.1: Liquid depth

Photo 1: Liquid depth 450 MHz body simulating liquid



Annex C: Photo documentation

Photo documentation is described in the additional document:

Appendix to test report no. 1-7215/18-03-03 Photo documentation

Annex D: Calibration parameters

Calibration parameters are described in the additional document:

Appendix to test report no. 1-7215/18-03-03 Calibration data, Phantom certificate and detail information of the DASY5 System

Annex E: RSS-102 Annex A and B

ICRF documents are described in the additional document:

Appendix to test report no. 1-7215/18-03-03_ICRF RF Technical Brief Cover Sheet acc. To RSS-102 Annex A and Declaration of RX Exposure Compliance Annex B

Annex F: Document History

Version	Applied Changes	Date of Release
	Initial Release	2019-02-01

Annex G: Further Information**Glossary**

DUT	-	Device under Test
EUT	-	Equipment under Test
FCC	-	Federal Communication Commission
FCC ID	-	Company Identifier at FCC
HW	-	Hardware
IC	-	Industry Canada
Inv. No.	-	Inventory number
N/A	-	not applicable
SAR	-	Specific Absorption Rate
S/N	-	Serial Number
SW	-	Software