

Wireless Conference System **WiCOS**



Deutsch

English

Français

Italiano

Español

Nederlands

Contents

Important safety instructions	2
WiCOS – the wireless conference system	5
Areas of application	5
The technology used	7
Available system components – scope of delivery	8
Overview of the components	9
WiCOS wireless conference units	10
WiCOS AP access point	18
Overview of the web server	19
WiCOS CASE transport case	20
Putting the conference system into operation	21
Putting the access point into operation	21
Putting the conference units into operation	25
Switching the components on/off	29
Switching the access point on/off	29
Switching a conference unit on/off	31
Running a conference	33
Operating a delegate unit	33
Operating a chairman unit	36
Configuring the conference system	43
Loading the factory default settings – “Reset”	43
Calling up the web server of the access point	44
Adjusting the basic settings – “Setup”	47
Adjusting the RF settings – “RF configuration”	52
Adjusting the conference settings – “Conference Management”	56
Additional functions – “Service”	66
Eavesdropping protection and encryption – “Encryption”	67
Transporting the conference system	70
Preparing the access point for transport	70
Preparing the conference units for transport	71
Using the transport case	72
Integrating WiCOS into a wired conference system	73
Connecting the access point to the SDC 8200 CU central unit	73
Initializing the conference units with the SDC 8200 CU central unit	75
Configuring the complete conference system - slave mode operation)	77
Using stand-alone operation in parallel with slave mode operation	78
Holding a conference in slave mode operation	79
Using the interpretation system	80
Cleaning the conference system	82
If a problem occurs	83
Accessories and spare parts	84
Specifications	85
Manufacturer Declarations	88
Index	90

Important safety instructions

- Read this instruction manual.
- Keep this instruction manual. Always include this instruction manual when passing the products on to third parties.
- Heed all warnings and follow all instructions in this instruction manual.
- Refer all servicing to qualified service personnel.
Servicing is required if the products have been damaged in any way, liquid has been spilled, objects have fallen inside, the products have been exposed to rain or moisture, do not operate properly or have been dropped.
- **WARNING:** To reduce the risk of fire or electric shock, do not use the products unit near water and do not expose them to rain or moisture. Do not place objects filled with liquids, such as vases or coffee cups, on the products.
- Only use the supplied mains units.
- Unplug the mains units from the wall socket
 - to completely disconnect the devices from the mains,
 - during lightning storms or
 - when unused for long periods of time.
- Only operate the mains units from the correct type of power source (see page 83).
- Ensure that the mains units are
 - in a safe operating condition and easily accessible,
 - properly plugged into the wall socket,
 - only operated within the permissible temperature range (see page 84).
 - not covered or exposed to direct sunlight for longer periods of time in order to prevent heat accumulation (see page 84).
- Do not block any ventilation openings. Install the products in accordance with the instructions given in this instruction manual.
- Do not install the products near any heat sources.
- Only use attachments/accessories specified by Sennheiser.

Overloading

Do not overload wall outlets and extension cables as this may result in fire and electric shock.

Replacement parts

When replacement parts are required, be sure the service technician uses replacement parts specified by Sennheiser or those having the same characteristics as the original part. Unauthorized substitutions may result in fire, electric shock, or other hazards.

Service and care

No user serviceable parts inside! Do not attempt to service devices yourself as opening or removing covers may expose dangerous voltage or other hazards. Refer all servicing to qualified service personnel.

Only use a slightly damp cloth to clean the devices. Do not use any cleansing agents or solvents.

Danger due to high volumes

These devices are capable of producing sound pressure exceeding 85 dB(A). 85 dB(A) is the sound pressure corresponding to the maximum permissible volume which is by law (in some countries) allowed to affect your hearing for the duration of a working day. It is used as a basis according to the specifications of industrial medicine. Higher volumes or longer durations can damage your hearing. At higher volumes, the duration must be shortened in order to prevent hearing damage. The following are sure signs that you have been subjected to excessive noise for too long a time:

- You can hear ringing or whistling sounds in your ears.
- You have the impression (even for a short time only) that you can no longer hear high notes.

Safety instructions for the Lithium-Ion battery pack

If abused or misused, the WiCOS BA battery pack may leak. In extreme cases, it may even present



- a heat hazard,
- a fire hazard,
- an explosion hazard,
- a smoke or gas hazard.

Please understand that Sennheiser does not accept liability for damage arising from abuse or misuse.

	Keep away from children.		Do not pack charged batteries loose – danger of shorting out/fire hazard.
	Observe correct polarity.		Do not short-circuit.
	Dispose of the battery pack at special collection points or return it to your specialist dealer.		Switch battery pack-powered devices off after use.
	Only charge the battery pack with the appropriate Sennheiser chargers.		When not using the battery pack for extended periods of time, charge it regularly (about every 3 months).
	Only charge the battery pack at ambient temperatures between 10 °C and 40 °C.		Do not heat above 70 °C/ 158 °F, e.g. do not expose to sunlight or throw into a fire.
	Do not mutilate or dismantle.		Do not continue to use a defective battery pack.
	Immediately remove the battery pack from an obviously defective device.		When not using the device for extended periods of time, remove the battery pack from the device.



Only use the original Sennheiser battery pack.



Do not expose to moisture.

Intended use

Intended use of the WiCOS wireless conference system includes:

- having read this instruction manual, especially the chapter “Important safety instructions” on page 2,
- using the system within the operating conditions and limitations described in this instruction manual.

“Improper use” means using the system other than as described in this instruction manual, or under operating conditions which differ from those described herein.

WiCOS – the wireless conference system

WiCOS stands for Wireless Conference System – the new generation of mobile and wireless conference equipment from Sennheiser. The WiCOS conference system utilizes all advantages of digital communications technology:

- Ease of use due to automatic configuration of the system
- Easy installation and straight-forward operation
- Conference units with up to 20 hrs operating time
- Decentralized, clear sound reproduction
- Conference units are extremely easy to operate
- Voting function
- Dynamic frequency management for intermodulation-free operation
- 2 usable frequency bands (2.4 GHz and 5 GHz)
- Easy integration of the wireless WiCOS system into the wired SDC 8200 digital conference system from Sennheiser
- Ideal for both small seminars with only a few participants and large conferences with any number of participants

Areas of application

The WiCOS conference system offers you reliable, wireless conferencing on the 2.4 GHz or 5 GHz frequency bands. The system architecture allows for different conference configurations:

Conference configuration	You can ...	You require ...
Standard operation	<ul style="list-style-type: none"> • run a discussion with optional assignment of the "speaking right" by a chairman 	<ul style="list-style-type: none"> • 1 WiCOS AP access point • WiCOS D delegate units • WiCOS C chairman unit (optional)
Extended operation	<ul style="list-style-type: none"> • run a discussion with assignment of the "speaking right" by a chairman • conduct voting session 	<ul style="list-style-type: none"> • 1 WiCOS AP access point • WiCOS DV delegate units • WiCOS CV chairman unit
integrated operation (slave mode operation)	<ul style="list-style-type: none"> • run a discussion with assignment of the "speaking right" by a chairman • offer simultaneous interpretation of the floor channel • conduct voting sessions • make use of the additional features of the Sennheiser SDC 8200 conference and interpretation system 	<ul style="list-style-type: none"> • WiCOS wireless conference system <ul style="list-style-type: none"> – 1 WiCOS AP access point – WiCOS DV delegate units – WiCOS CV chairman unit • wired SDC 8200 conference and interpretation system <ul style="list-style-type: none"> – SDC 8200 CU-M or CU central unit – SDC 8200 ID interpreter units – SDC 8200 conference units

Stand-alone operation – wireless conferencing

For stand-alone operation, you only require the WiCOS system components. You can use different conference modes and, in addition to running discussions, you can also conduct voting sessions.

The delegate and chairman units are wirelessly connected to the access point, which acts as the central unit and controls the conference system. The battery pack-powered conference units are wireless and can be placed as you wish.

The access point has an integrated web server for configuring and monitoring the WiCOS conference system. In order to control these functions, a computer with network connection and a web browser is needed.

Setup for stand-alone operation

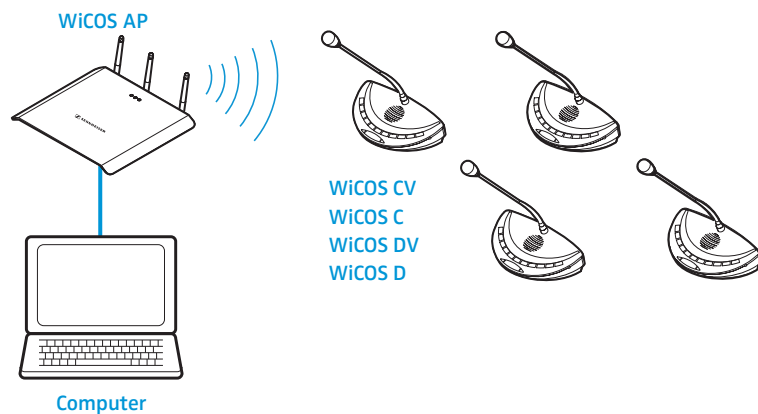

Integrated operation (slave mode operation) – with the wired SDC 8200 conference and interpretation system

The WiCOS wireless conference system can be integrated into the wired SDC 8200 conference and interpretation system. This allows you to expand the conference system and/or easily bridge relatively long distances. In slave mode operation, you can use the WiCOS system for simultaneous interpretation and add professional accessories such as room microphones, camera functions or the software control of the SDC 8200 conference and interpretation system.

For slave mode operation, you require the SDC 8200 conference and interpretation system with the SDC 8200 CU-M or SDC 8200 CU central unit. One or several access points can be connected to the central unit. As in stand-alone operation, the access point controls the wireless communication between the conference units. The conference system is configured via the SDC 8200 CU-M or SDC 8200 CU central unit. In integrated operation, all conference units of the wireless WiCOS system behave like conference units of the SDC 8200 system.

To use language distribution, you also require SDC 8200 interpreter units. The WiCOS DV and WiCOS CV conference units allow you to select between up to 16 interpretation channels.

Setup for integrated operation
(slave mode operation)

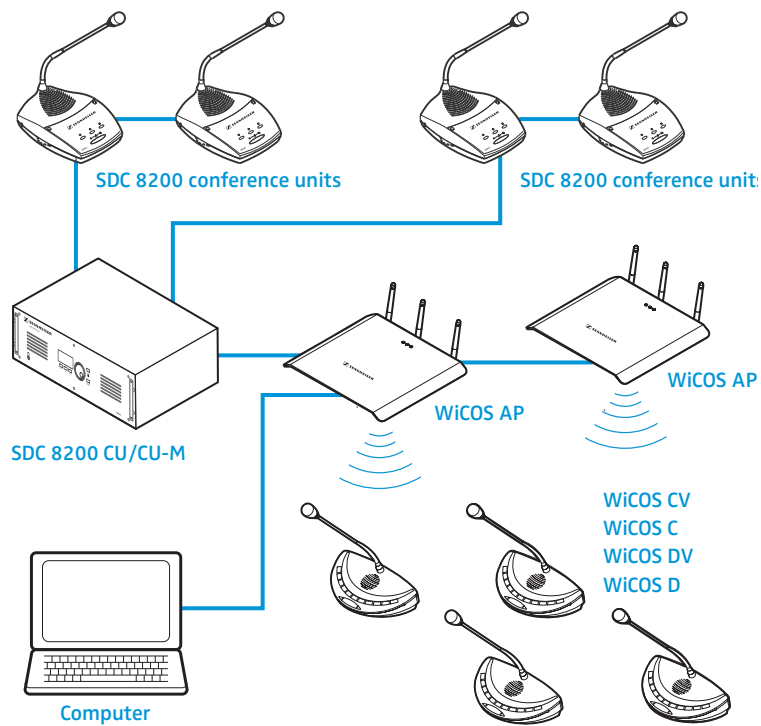

The technology used

The radio technology of the WiCOS conference system is based on the transmission standard for radio networks IEEE 802.11 a/g which is widespread in computer technology. This radio standard offers the largest possible operational reliability and transmission quality. The radio protocols are optimized for conferencing, thus avoiding intermodulations with existing radio networks. The dynamic frequency management of the WiCOS conference system automatically detects occupied frequency bands and changes to a free frequency band with no interruptions, even during operation.

Available system components – scope of delivery

The following WiCOS system components are available:

Delegate unit	<ul style="list-style-type: none">1 WiCOS D delegate unit (without voting function) or WiCOS DV delegate unit (with voting function and channel selection keys)1 WiCOS MIC gooseneck microphone1 WiCOS BA Lithium-Ion battery pack
Chairman unit	<ul style="list-style-type: none">1 WiCOS C chairman unit (without voting function) or WiCOS CV chairman unit (with voting function and channel selection keys)1 WiCOS MIC gooseneck microphone1 WiCOS BA Lithium-Ion battery pack
Charging power supply for battery pack	<ul style="list-style-type: none">1 WiCOS NT-BA charging power supply for WiCOS BA battery pack3 country adapters (EU/UK/US)
Access point	<ul style="list-style-type: none">1 WiCOS AP access point3 rod antennas3 country adapters (EU/UK/US)1 network cable (Cat5)1 CD ROM with instruction manual (PDF file)
DC power supply for access point	<ul style="list-style-type: none">1 WiCOS NT-AP DC power supply for WiCOS AP access point3 country adapters (EU/UK/US)
Transport case	<ul style="list-style-type: none">1 WiCOS CASE transport case (with wheels) for one conference system with up to 12 conference units and accessories

Overview of the components

Your conference system can comprise the following conferences units:

Conference unit	Functions	Overview
WiCOS D	Delegate unit for discussions <ul style="list-style-type: none"> • 2 headphone sockets for the floor channel 	page 10
WiCOS C	Chairman unit with moderator function <ul style="list-style-type: none"> • Next key and priority key • 2 volume control keys for the conference units' built-in loudspeakers • 2 headphone sockets for the floor channel 	page 11
WiCOS DV	Delegate unit for discussions including votes and language distribution <ul style="list-style-type: none"> • 3 voting keys • 2 channel selection keys • 2 headphones sockets for interpretation channels and the floor channel 	page 12
WiCOS CV	Chairman unit with moderator function and voting administrator function <ul style="list-style-type: none"> • Next key and priority key • 3 operating modes <ul style="list-style-type: none"> – voting mode – volume adjustment mode for the conference units' built-in loudspeakers – media control mode • 3 voting keys • 2 channel selection keys • 2 headphones sockets for interpretation channels and the floor channel 	page 14

The conference system also comprises:

Central unit	Function	Overview
WiCOS AP access point	<ul style="list-style-type: none"> • Controls the communication of the conference units • Configuration via web server • Can be integrated in a network 	page 18

You can also integrate the WiCOS conference system into the wired SDC 8200 conference system and interpretation system (see page 73).

WiCOS wireless conference units

WiCOS D delegate unit

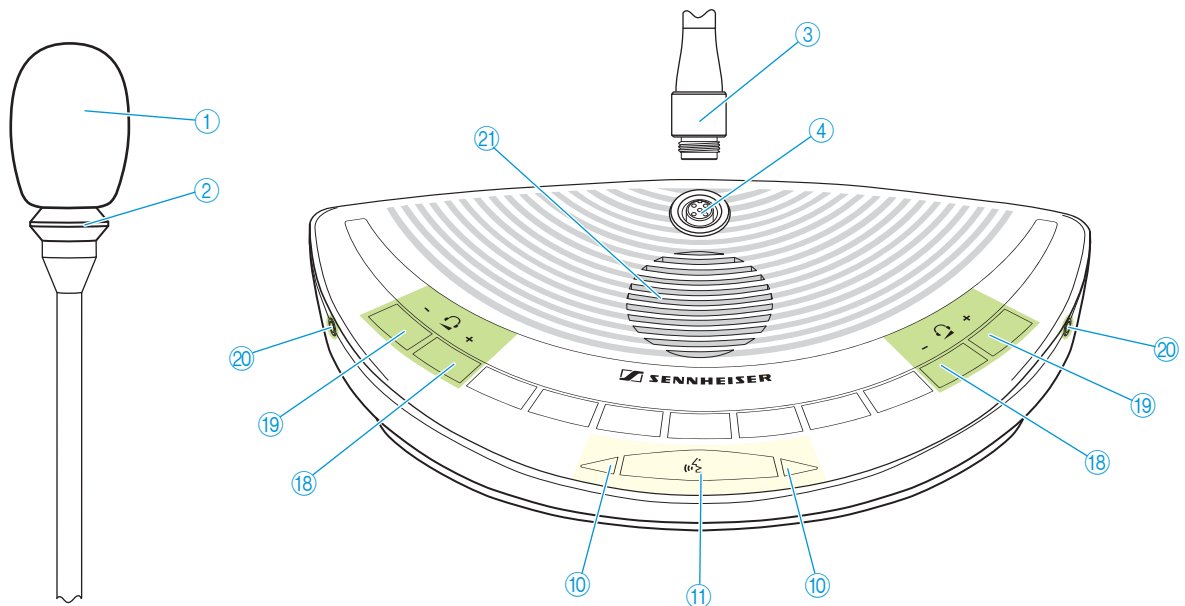

Operating element	Function/Meaning	Group
① Sound inlet basket	for contributing to the discussion	Gooseneck microphone
② Signal light ring	indicates the "speaking right" or a request to speak	
③ Coupling ring	locks the microphone	
④ Microphone socket	for connection of the microphone, with indentation for correct orientation	
⑩ Microphone LED	indicates a request to speak, the "speaking right" and the connection status of the conference unit	Conferencing
⑪ Microphone key	switches the conference unit on/off and controls the microphone	
⑱ Headphone volume UP	increases the headphone volume	Sound output
⑲ Headphone volume DOWN	reduces the headphone volume	
⑳ Headphone socket	outputs the floor channel to headphones	
㉑ Loudspeaker	outputs the floor channel	

For an overview of the operating elements at the rear of the conference unit, refer to page 17.

WiCOS C chairman unit

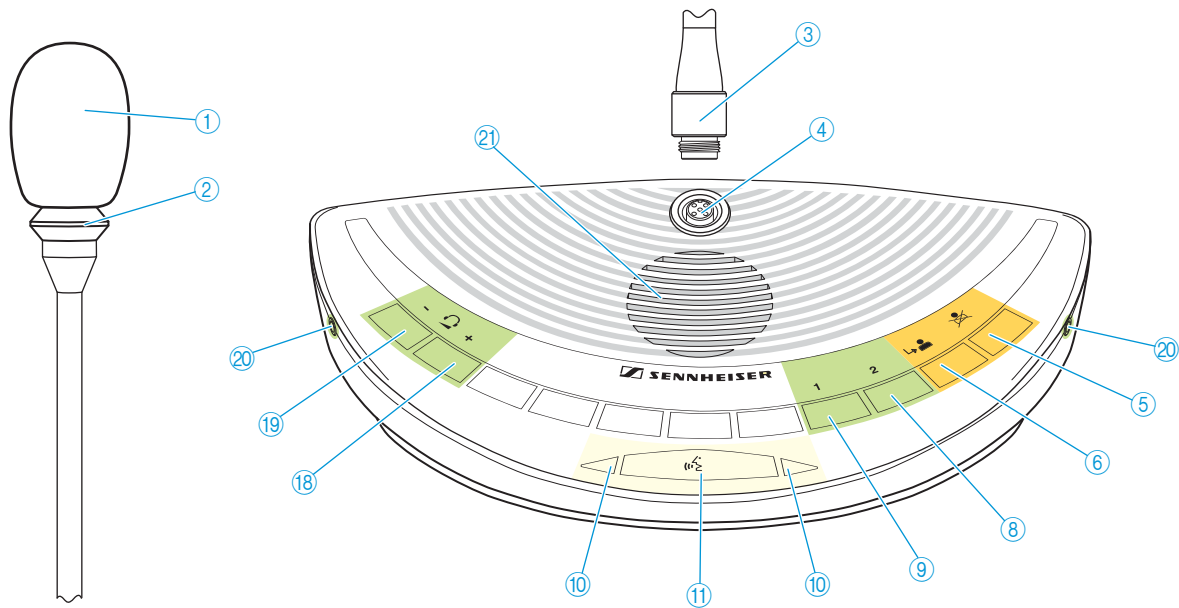

Operating element	Function/Meaning	Group
① Sound inlet basket	for contributing to the discussion	Gooseneck microphone
② Signal light ring	indicates the "speaking right" or a request to speak	
③ Coupling ring	locks the microphone	
④ Microphone socket	for connection of the microphone, with indentation for correct orientation	
⑤ Priority key	temporarily mutes all conference units or stops the discussion	Chairman functions
⑥ Next key	assigns the "speaking right" to a participant from the request-to-speak list	
⑩ Microphone LED	indicates a request to speak, the "speaking right" and the connection status of the conference unit	Conferencing
⑪ Microphone key	switches the conference unit on/off and controls the microphone	
⑧ Selection key A	increases the loudspeaker volume on the conference units, stops a voting session, controls external media devices (depending on the operating mode)	Sound output
⑨ Selection key B	reduces the loudspeaker volume on the conference units, starts a voting session, controls external media devices (depending on the operating mode)	
⑱ Headphone volume UP	increases the headphone volume	
⑲ Headphone volume DOWN	reduces the headphone volume	
⑳ Headphone socket	outputs the floor channel to headphones	
㉑ Loudspeaker	outputs the floor channel	Conference unit

For an overview of the operating elements at the rear of the conference unit, refer to page 17.

WiCOS DV delegate unit with voting function

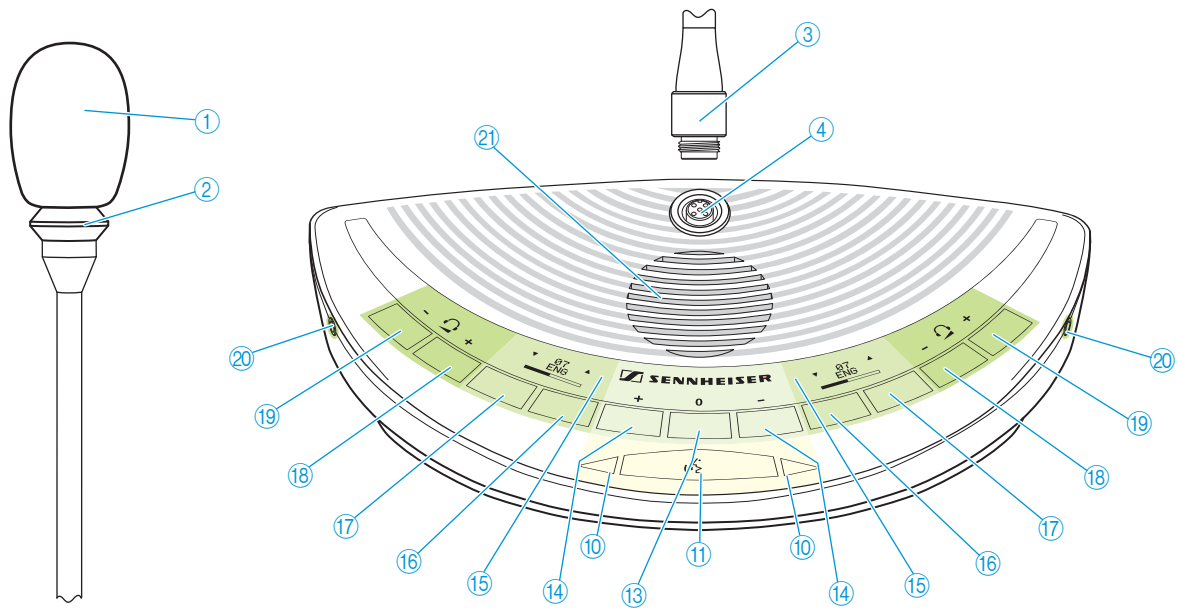

Operating element	Function/Meaning	Group
① Sound inlet basket	for contributing to the discussion	Gooseneck microphone
② Signal light ring	indicates the "speaking right" or a request to speak	
③ Coupling ring	locks the microphone	
④ Microphone socket	for connection of the microphone, with indentation for correct orientation	
⑩ Microphone LED	indicates a request to speak, the "speaking right" and the connection status of the conference unit	Conferecing
⑪ Microphone key	switches the conference unit on/off and controls the microphone	Conferecing
⑫ NO key	votes "no" in a voting session	Voting keys
⑬ ABSTAIN key	votes "abstain" in a voting session	
⑭ YES key	votes "yes" in a voting session	
⑮ Channel selection display	displays the interpretation channel, the voting results and the headphone volume	Language distribution
⑯ CHANNEL UP key	selects the next interpretation channel	
⑰ CHANNEL DOWN key	selects the previous interpretation channel	Sound output
⑱ Headphone volume UP	increases the headphone volume	
⑲ Headphone volume DOWN	reduces the headphone volume	Sound output
⑳ Headphone socket	outputs the floor channel and the interpretation channels to headphones	
㉑ Loudspeaker	outputs the floor channel	Sound output

For an overview of the operating elements at the rear of the conference unit, refer to page 17.

Channel selection display 15 of the WiCOS DV delegate unit

The channel selection display 15 can display two different views.

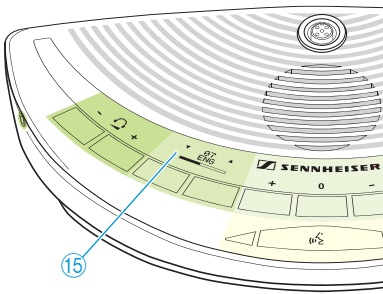

Interpretation channel selection	Display	Function/Meaning
	27 Direction of the CHANNEL UP key 16 and the CHANNEL DOWN key 17	selects the next or the previous channel
	28 Channel number and channel name	displays the current channel output via the headphones Default setting: floor channel "00 FLOOR"
	29 Headphone volume	displays the adjusted volume on the headphone socket 20
Voting result	Display	Function/Meaning
	30 Voting result	displays the voting result after the voting session has ended

The display has an automatic brightness control. Approx. 4 seconds after the last key press, the brightness will be reduced. With each key press, the display will light up with maximum brightness.

WiCOS CV chairman unit with voting function

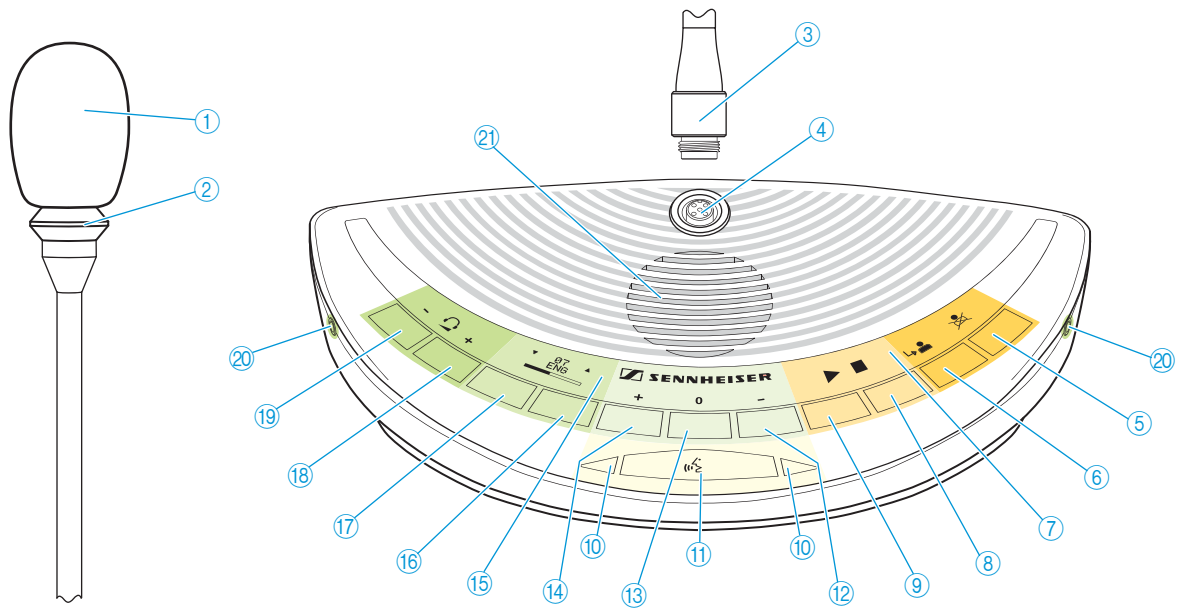

Operating element	Function/Meaning	Group
① Sound inlet basket	for contributing to the discussion	Gooseneck microphone
② Signal light ring	indicates the "speaking right" or a request to speak	
③ Coupling ring	locks the microphone	
④ Microphone socket	for connection of the microphone, with indentation for correct orientation	
⑤ Priority key	temporarily mutes all conference units or stops the discussion	Chairman functions
⑥ Next key	assigns the "speaking right" to a participant from the request-to-speak list	
⑦ Multi-function display	displays the voting mode, the loudspeaker mode of the conference units and the media control mode	Voting and media functions
⑧ Selection key A	increases the loudspeaker volume on the conference units, stops a voting session, controls external media devices (depending on the operating mode)	
⑨ Selection key B	reduces the loudspeaker volume on the conference units, starts a voting session, controls external media devices (depending on the operating mode)	Voting and media functions
⑩ Microphone LED	indicates a request to speak, the "speaking right" and the connection status of the conference unit	
⑪ Microphone key	switches the conference unit on/off and controls the microphone	Confereencing
⑫ NO key	votes "no" in a voting session	
⑬ ABSTAIN key	votes "abstain" in a voting session	Voting keys
⑭ YES key	votes "yes" in a voting session	
⑮ Channel selection display	displays the interpretation channel, the voting results and the headphone volume	Language distribution
⑯ CHANNEL UP key	selects the next interpretation channel	
⑰ CHANNEL DOWN key	selects the previous interpretation channel	Sound output
⑱ Headphone volume UP	increases the headphone volume	
⑲ Headphone volume DOWN	reduces the headphone volume	Sound output
⑳ Headphone socket	outputs the floor channel and the interpretation channels to headphones	
㉑ Loudspeaker	outputs the floor channel	Sound output

For an overview of the operating elements at the rear of the conference unit, refer to page 17.

Multi-function display ⑦ of the WiCOS CV chairman unit

The multi-function display ⑦ can display three different operating modes. To switch between the operating modes and displays:

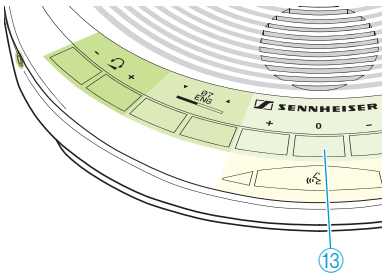

- ▶ Press the ABSTAIN key ⑬ for approx. 3 seconds. You can switch between the following modes and displays:
 - Voting mode (“Start/Stop Voting”)
 - Volume adjustment mode for loudspeakers (“Volume Control”) and
 - Media control mode (“Function key”).
 Depending on the mode, the selection key A ⑧ and the selection key B ⑨ are assigned different functions.

i You can also switch between the operating modes using the web server (see page 65).

Operating Mode	Display	Function/Meaning
Voting mode “Start/Stop Voting”	②② Start ②③ Stop	Selection key B ⑨ starts a voting session Selection key A ⑧ stops a voting session
Volume adjustment mode for loudspeakers “Volume Control”	②④ Volume of the conference units’ loudspeakers	Adjusted volume of the conference units’ loudspeakers ②① Selection key A ⑧ increases the volume Selection key B ⑨ reduces the volume
Media control mode “Function key”	②⑤ Media control 1 ②⑥ Media control 2	Selection key A ⑧ controls external media devices Selection key B ⑨ controls external media devices

The display has an automatic brightness control. Approx. 4 seconds after the last key press, the brightness will be reduced. With each key press, the display will light up with maximum brightness.

Channel selection display 15 of the WiCOS CV delegate unit

The channel selection display 15 can display two different views.

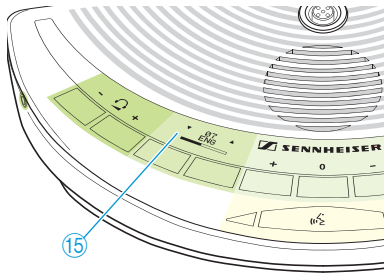

Interpretation channel selection	Display	Function/Meaning
	27 Direction of the CHANNEL UP key 16 and the CHANNEL DOWN key 17	selects the next or the previous channel
	28 Channel number and channel name	displays the current channel output via the headphones Default setting: floor channel "00 FLOOR"
	29 Headphone volume	displays the adjusted volume on the headphone socket 20
Voting result	Display	Function/Meaning
	30 Voting result	displays the voting result after the voting session has ended

The display has an automatic brightness control. Approx. 4 seconds after the last key press, the brightness will be reduced. With each key press, the display will light up with maximum brightness.

Rear of the conference console

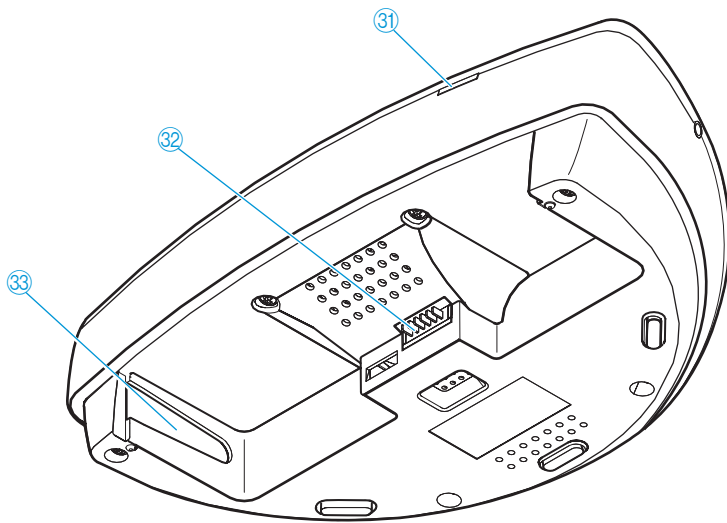

Operating element	Function/Meaning
31 RF link indicator	displays the connection status with the access point
32 Battery pack connection	for connection to the WiCOS BA battery pack
33 Battery guide rails	ensure correct insertion of the WiCOS BA battery pack

WiCOS BA Lithium-Ion battery pack

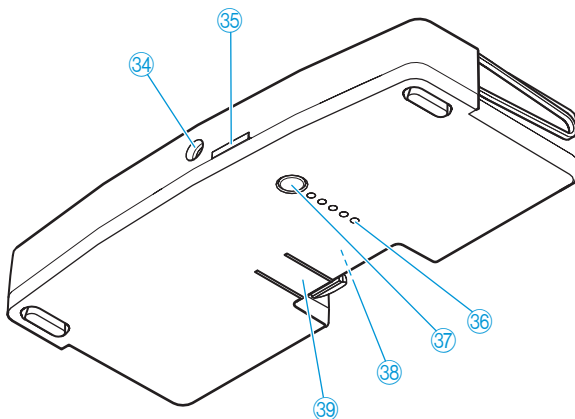

Operating element	Function/Meaning
34 Socket for charging power supply	for connection of the charging power supply, charges the battery pack and allows mains operation
35 Status indicator	displays the charging process and mains operation
36 Charge status indicator	displays the charge status and the status of the charging electronics
37 Key	activates the charge status indicator 36 and the charging electronics indicator
38 Contacts	for connecting the battery pack to the conference unit
39 Battery release clip	secures the battery pack against inadvertent detachment from the conference unit

WiCOS AP access point

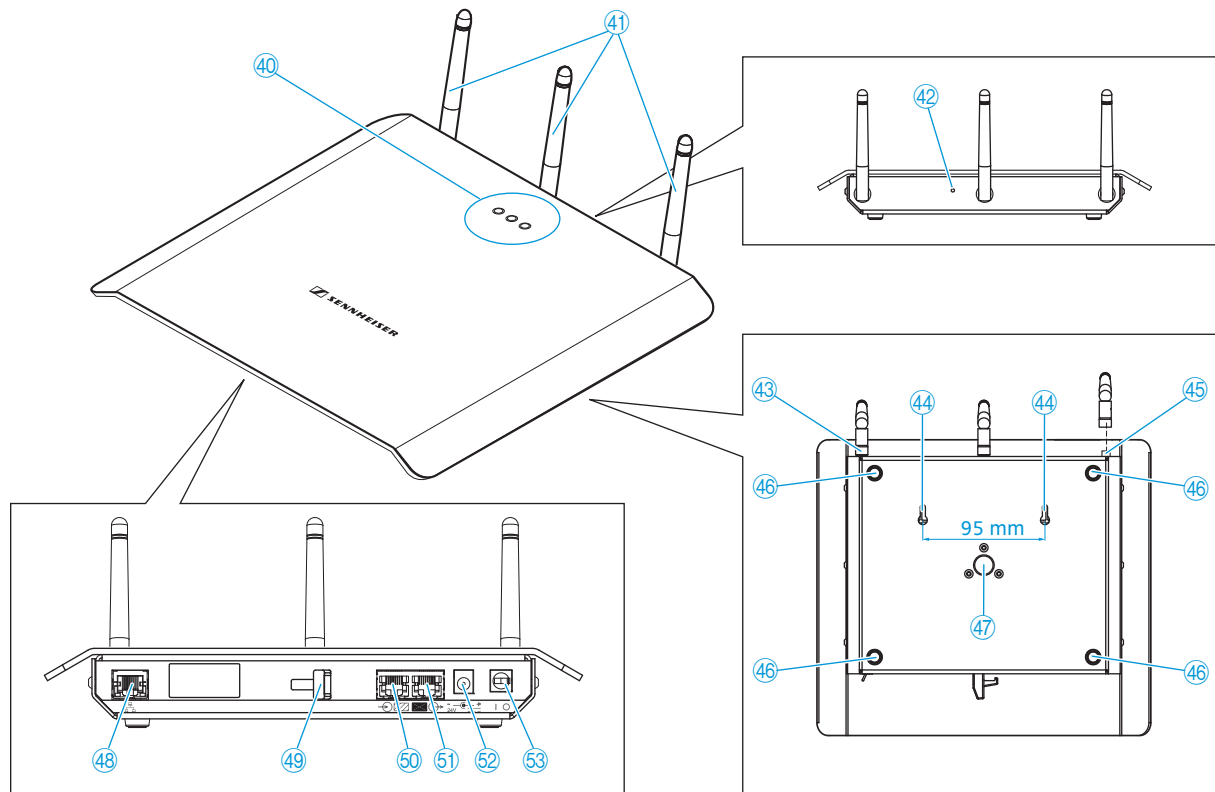

Operating element	Function/Meaning
④① Status indicators	displays the operating mode, the connection status and the RF signal quality
④① Antennas	transmit and receive RF signals, adjustable
④② Reset key	resets the access point to the factory default settings
④③ Antenna coupling ring	locks the antennas
④④ Eyelets for wall mounting	for mounting the access point to a wall
④⑤ Antenna sockets	for connection of the antennas
④⑥ Rubber feet	ensure that the access point cannot slip on the surface on which it is placed
④⑦ Stand mount	for mounting the access point to a stand with 5/8" mounting stud
④⑧ Network socket (RJ 45)	for connection to a network or computer to configure and monitor the conference system via the web server
④⑨ Cable grip	ensures that the cable cannot slip out of the socket for DC power supply
⑤① IN system socket (RJ 45)	for connection of the SDC 8200 conference and interpretation system
⑤② OUT system socket (RJ 45)	for connection of additional access points
⑤③ Socket for DC power supply	for connection of the WiCOS NT-AP DC power supply
⑤④ On/off switch	switches the access point on/off

Overview of the web server



Operating element	Function/Meaning
54 Main navigation	Tabs of the main navigation level, always visible
55 Subnavigation	Second navigation level, depending on the main navigation
56 Structure of the current category	Different topics and categories of the current configuration page
57 Overview and configuration contents	Selection possibilities and/or listing of the current configurations contents
58 Help on the current category	Explanations on the current configuration page

Main navigation	Subnavigation	Detailed information
"Setup"	"Summary"	page 47
	"TCP/IP settings"	page 48
	"Country Selection"	page 50
	"Admin"	page 51
"RF Configuration"	"General"	page 52
	"Quality 2.4 GHz ISM"	page 54
	"Quality 5.15-5.35 GHz"	page 54
	"Quality 5.47-5.725 GHz"	page 54
"Conference Management"	"Quality 5.8 GHz ISM"	page 54
	"General"	page 57
	"Unit Monitoring"	page 61
	"Init Units"	page 62
"Service"	"Chairman Config"	page 65
	"Logging"	page 66
"Encryption"	"Update"	page 67
	"Key assignment"	page 68

WiCOS CASE transport case

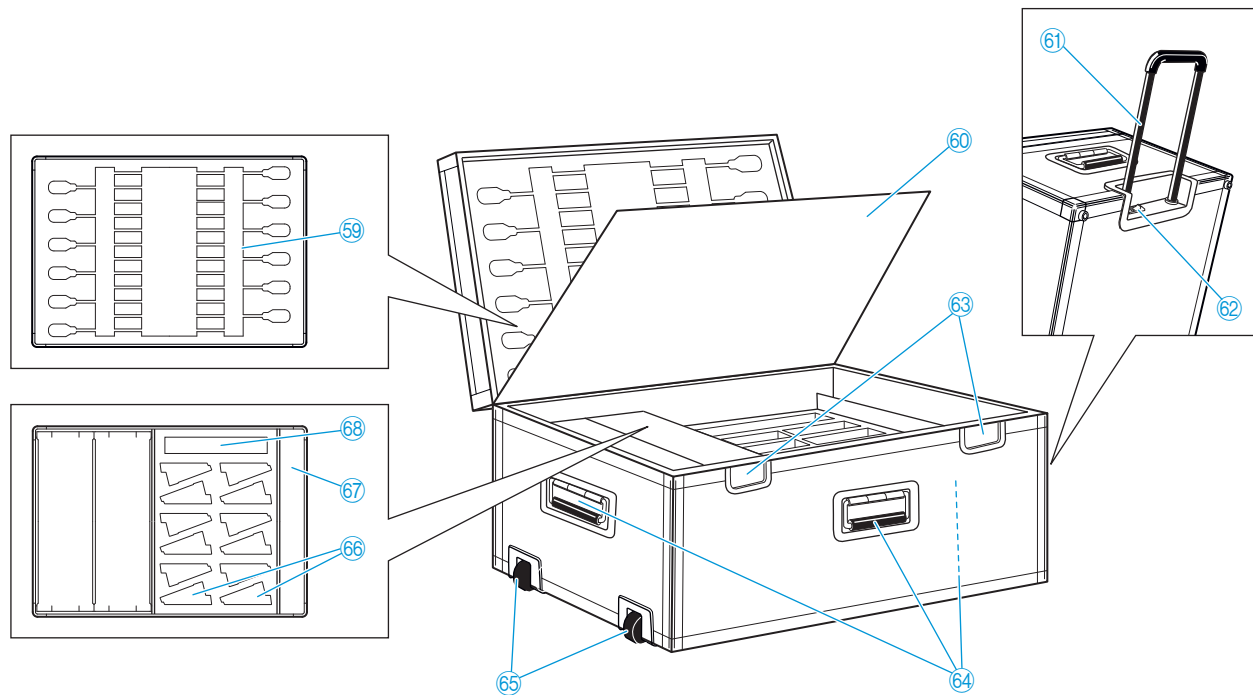

Operating element	Function/Meaning
59 Microphone holder	holds up to 12 gooseneck microphones
60 Lid	separates the upper and lower shell of the case
61 Telescopic handle	for pulling the transport case on its wheels
62 Catch	locks the telescopic handle
63 Lock	locks the transport case, can be locked with U-locks
64 Carrying handle	for carrying the transport case
65 Wheels	for easy transportation
66 Conference unit holder	holds up to 12 conference units with inserted battery packs
67 Accessory compartment	stores mains power supplies, accessories, cables, etc.
68 Access point holder	holds an access point

Putting the conference system into operation

Putting the access point into operation

The access point controls the wireless communication between the individual conference units.

Connecting the antennas

The supplied rod antennas are mounted quickly and easily. They ensure reliable radio transmission within buildings. The transmission range is approx. 30 m. Always connect all 3 antennas to ensure reliable radio communication.

CAUTION! Radio communication outside the legal requirements!

When connecting antennas other than the supplied ones, the transmission power of the conference system may not meet the legal requirements.

- ▶ Only connect the supplied antennas to the access point.

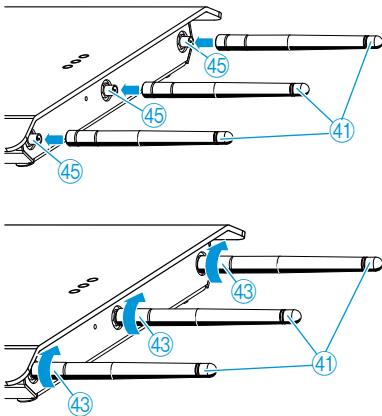

- ▶ Connect the 3 antennas (41) to the antenna sockets (45).

- ▶ Screw down the 3 antenna coupling rings (43) as shown. The antennas are locked.

Connecting the access point to the mains



When connecting the access point via a system cable to the SDC 8200 CU-M or SDC 8200 CU central unit of the SDC 8200 conference and interpretation system, you do not require the WiCOS NT-AP DC power supply.

CAUTION! Danger due to electric current!

If you use an unsuitable power supply, this can cause damage to the access point.

- ▶ Only connect the WiCOS NT-AP DC power supply to the access point.

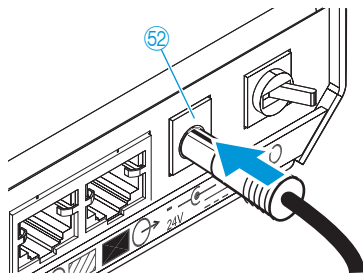

- ▶ Connect the DC power supply 69 to the socket 52.

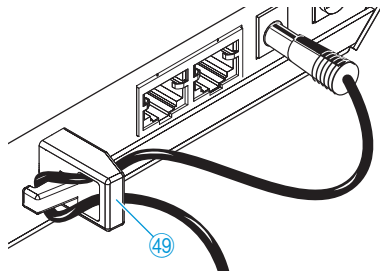

- ▶ Pass the cable of the DC power supply through the cable grip 49 as shown.

NT-AP

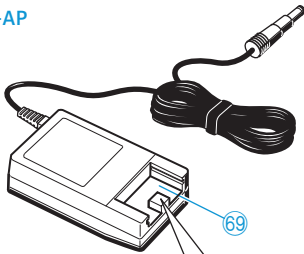

- ▶ Slide the supplied country adapter 70 onto the DC power supply 69.
- ▶ Plug the DC power supply into a wall socket.

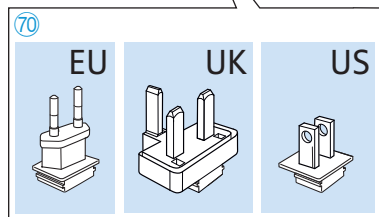

Connecting the access point to a computer/network

In order to change the configuration of the access point or to monitor the conference system, you require a computer with network connection (RJ 45) and a web browser.

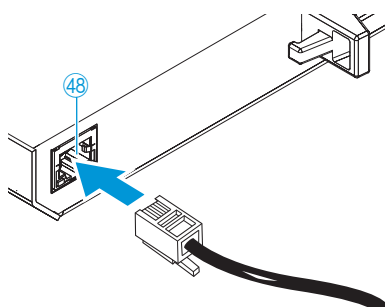

- ▶ Connect the supplied network cable (Cat5) to the network socket (RJ 45) 48.

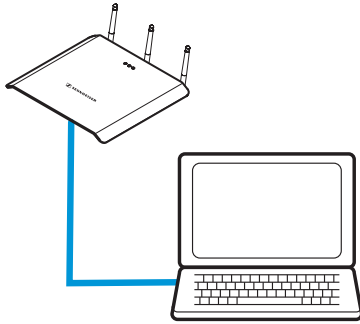

- ▶ Connect the network cable to your computer or network.
- ▶ Call up the web server (see page 44).

Connecting a system cable for integrated operation

To integrate the WiCOS conference system into a wired SDC 8200 conference and interpretation system:

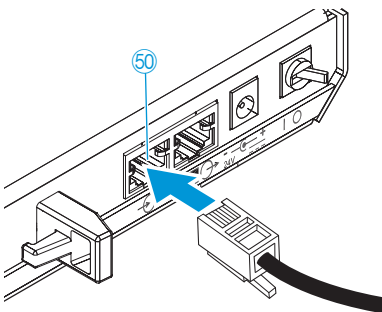

- ▶ Connect a system cable (Sennheiser SDC CBL RJ45, see "Accessories and spare parts" on page 83) to the IN system socket (RJ 45) 50.

- ▶ Connect the system cable to one of the six RJ 45 sockets ("PORT 1-6" of the SDC 8200 CU-M or SDC 8200 CU central unit (see page 70 and the instruction manual of the SDC 8200 conference and interpretation system).

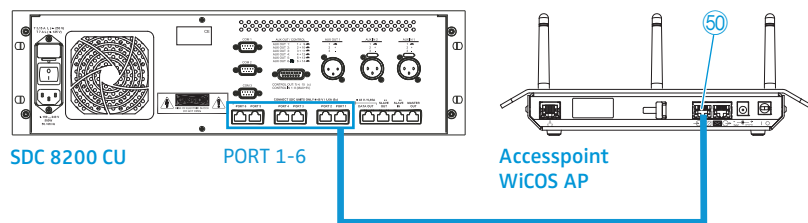

Setting up the access point

CAUTION! Danger of intermodulation!

If you set up the individual components of the conference system too close to one another, intermodulation can occur.

- ▶ Observe a minimum distance of 1.5 m between the access point and the conference units.
- ▶ Observe a minimum distance of 50 cm between the conference units.

- ▶ If possible, set up the devices so that there is a "free line of sight" between the conference units and the access point.

To obtain the optimum transmission range:

- ▶ Place the access point as centrally and as high as possible.

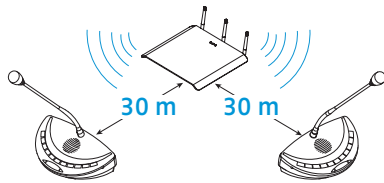

The transmission range of the conference units and the access point is approx. 30 m. The transmission range can vary depending on location and environmental conditions such as wall thickness, wall composition etc.

The access point can be

- mounted to a wall or ceiling or
- mounted on a stand or
- placed on a flat surface (e.g. table),

Mounting the access point to a wall or ceiling

- ▶ Use suitable screws and the eyelets for wall mounting (44) at the rear of the access point to mount the access point to a wall.

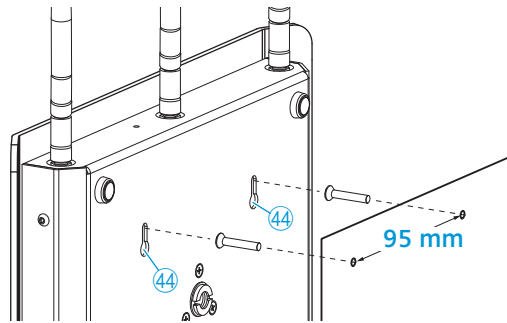

Mounting the access point on a stand

- ▶ Use a stand with 5/8" mounting stud (adapter to 3/8" mounting stud available as optional accessory, see "Accessories and spare parts" on page 83).
- ▶ Adjust the legs of the stand.
- ▶ Use the stand mount (47) to screw the access point on the stand.

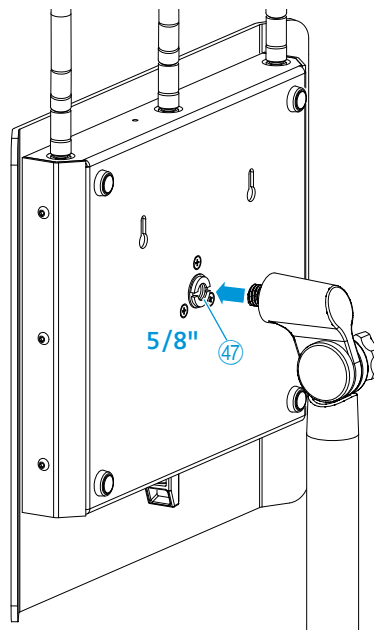

Placing the access point on a flat surface

CAUTION! Risk of staining of furniture surfaces!

Some furniture surfaces have been treated with varnish, polish or synthetics which might cause stains when they come into contact with other synthetics. Despite a thorough testing of the synthetics used by us, we cannot rule out the possibility of staining.

- ▶ Do not place the access point on delicate surfaces.

Aligning the antennas

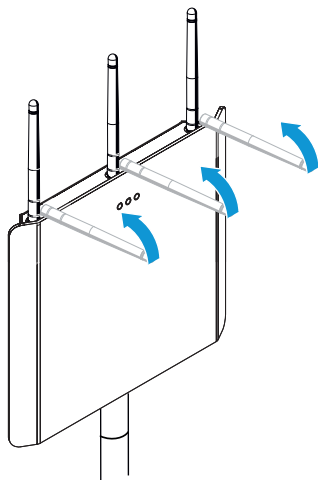

- ▶ Place the access point on a flat, horizontal surface.
- ▶ Align the 3 antennas vertically.
- ▶ Switch the access point on (see page 29).

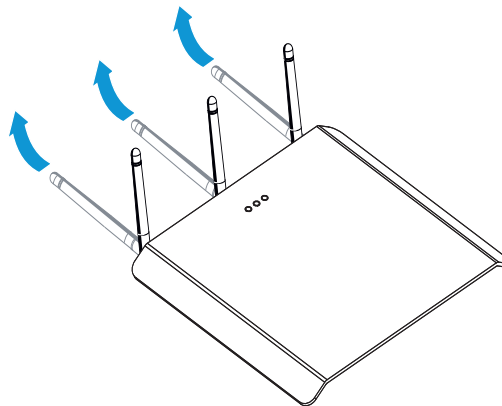

Putting the conference units into operation

Connecting the microphone

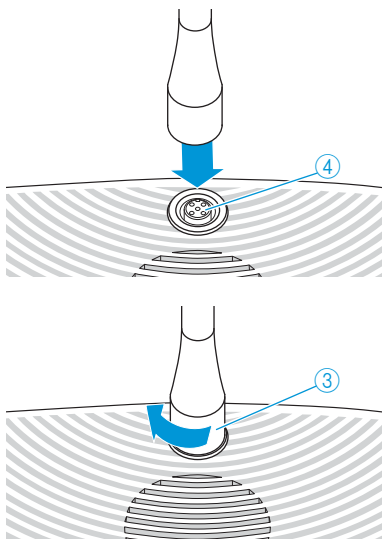

- ▶ Connect the gooseneck microphone to the microphone socket ④ so that the protrusion engages with the indentation.

- ▶ Screw down the coupling ring ③.
The microphone is securely connected to the conference unit.

- ▶ Set up the conference unit so that it can be comfortably operated by the participant.
- ▶ Tilt the microphone toward the participant.

Checking the charge status of the battery pack

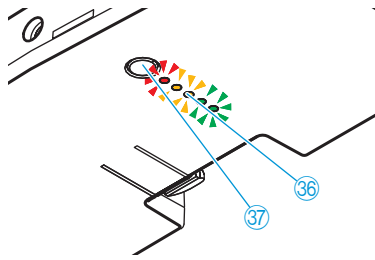

- ▶ Press the key 37.
The charge status indicator 36 displays the current charge status:

LED 36	lights up	Remaining capacity	Remaining operating time
1	red	0-20 %	approx. 4 hours
2	orange	20-40 %	approx. 4-8 hours
3	orange	40-60 %	approx. 8-12 hours
4	green	60-80 %	approx. 12-16 hours
5	green	80-100 %	approx. 16-20 hours

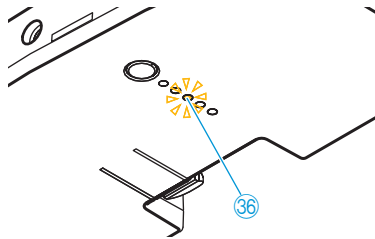

The charge status indicator 36 goes off after approx. 5 seconds. The LED 3 then display the status of the charging electronics.

LED 36	flashes	Charging electronics
3	orange	functions properly
3	–	defective

The LED 3 goes off after approx. 7 seconds.

CAUTION! Danger of burns and damage to the device!



A defective battery pack can ignite and destroy the conference unit!

- ▶ Disconnect the charging power supply from the defective battery pack.
- ▶ Remove the defective battery pack from the conference unit.
- ▶ Dispose of the defective battery pack in accordance with the regulations.

C CV D DV

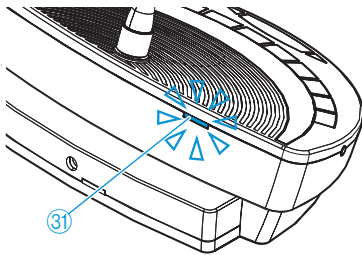

When the battery pack is almost flat, the status indicator 31 indicates the remaining operating time.

Red LED 31 flashes approx. ... per second	Remaining operating time
once	approx. 4 hours
twice	approx. 2 hours
four times	approx. 1 hour

Charging the battery pack

The WiCOS BA Lithium-Ion battery pack is pre-charged upon delivery, i.e. you can immediately use the conference unit without having to charge the battery pack first.

There are two ways to charge the battery pack, both using the WiCOS NT-BA charging power supply:

- You can charge the battery pack separately.
- You can charge the battery pack when it is inserted into the conference unit.

The conference unit can be operated during the charging process.

CAUTION! Danger due to electric current!

If you use an unsuitable charging power supply, this can cause damage to the battery pack.

- ▶ Only use the WiCOS NT-BA charging power supply to charge the WiCOS BA battery pack.

To connect the WiCOS NT-BA charging power supply:

- ▶ Slide the supplied country adapter ⑦⑩ onto the charging power supply ⑥⑨.

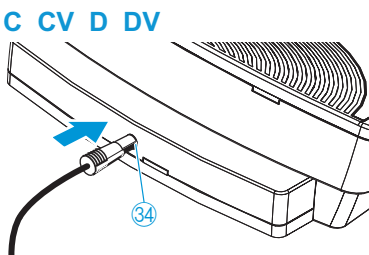
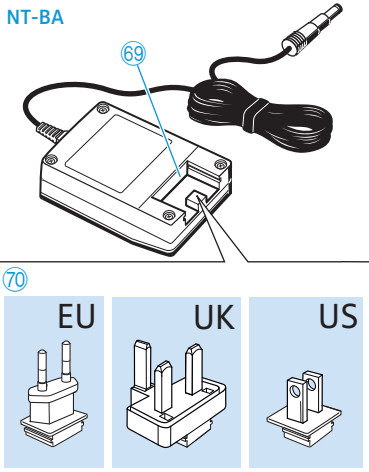

- ▶ Plug the charging power supply into a wall socket.
- ▶ Connect the plug of the charging power supply ⑥⑨ to the socket ③④ of the battery pack.
The charging process starts.

When you have connected the charging power supply to the battery pack, the status indicator ③⑤ and the charge status indicator ③⑥ provide information on the charging process and on mains operation:

Status indicator ③⑤	Charge status indicator ③⑥	Charging process
green and yellow	lights up (indicating the current charge status)	the battery pack is being charged, a complete charging process takes approx. 4 hours
green	off	the battery pack is fully charged, mains operation

Inserting/removing the battery pack

To **insert** the WiCOS BA into the conference unit:

- ▶ Check the battery pack before using it (see page 26) in order to ensure sufficient battery capacity and to exclude a defective battery pack.

- ▶ Slide the battery pack into the battery guide rails 33 of the conference unit.
The battery release clip 39 locks into place.

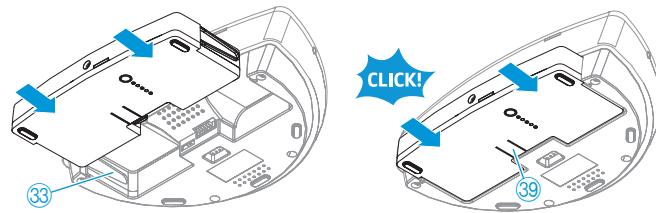

- ▶ Switch the conference unit on (see page 31).

To **remove** the battery pack from the conference unit:

- ▶ Press the battery release clip 39 and pull the battery pack out of the battery guide rails.

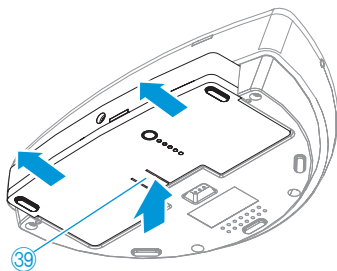

Setting up the conference units

CAUTION! Danger of intermodulation!

If you set up the individual components of the conference system too close to one another, intermodulation can occur.

- ▶ Observe a minimum distance of 1.5 m between the conference units and the access point.
- ▶ Observe a minimum distance of 50 cm between the conference units.

- ▶ If possible, set up the devices so that there is a "free line of sight" between the conference units and the access point.

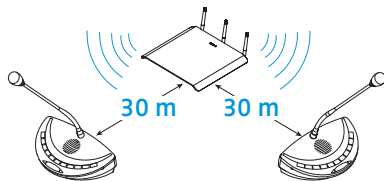

The transmission range of the conference units and the access point is approx. 30 m. The transmission range can vary depending on location and environmental conditions such as wall thickness, wall composition etc.

CAUTION! Risk of staining of furniture surfaces!

Some furniture surfaces have been treated with varnish, polish or synthetics which might cause stains when they come into contact with other synthetics. Despite a thorough testing of the synthetics used by us, we cannot rule out the possibility of staining.

- ▶ Do not place the access point on delicate surfaces.
- ▶ Place the conference units on a flat, horizontal surface.

Switching the components on/off

To switch the WiCOS conference system on, proceed as follows:

1. Switch the access point on (see next chapter).
2. Switch the conference units on (see page 31).

The connection is automatically established. The conference system loads the last configuration used (see next chapters).

Switching the access point on/off

To switch the access point **on**:

- ▶ Set the on/off switch **53** to position "1".
The last configuration used is loaded. The 3 status indicators **40** provide the following information:

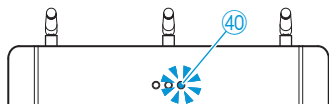
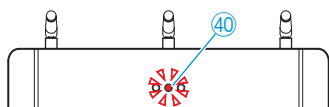
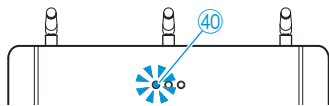
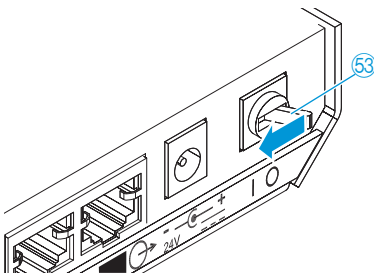

Blue LED 1	Operating mode of the access point
flashes slowly	integrated operation (slave mode)
lights up	stand-alone operation

Red LED 2	Link quality (RF signal quality)
off	excellent
flashes slowly	good
flashes rapidly	fair
lights up	low

Blue LED 3	Connection status with the conference units
flashes rapidly	no connection
lights up	connection with at least 1 conference unit

You can use the factory default settings or adapt the configuration to your needs (see page 43):

Configuration	Function/Meaning	Detailed information
Network settings (IP address)	To load the web server and to modify the configuration	see page 48
Country settings for radio communication	To set country-specific limit values for radio frequencies and transmission power	see page 50
Password protection	To protect the web server from unauthorized access	see page 51
RF signal strength	To set the transmission power	see page 52
Radio frequency	To set the radio frequencies to be used in the 2.4 GHz and 5 GHz frequency bands	see page 52

Configuration	Function/Meaning	Detailed information
Max. number of simultaneously active microphones	To set the max. number of simultaneously active microphones in a discussion	see page 56
Conference mode	To set the conference mode	see page 57
Loudspeaker volume	To set the volume of the conference units' loudspeakers	see page 59
Number of interpretation channels	To set the number of the interpretation channels	see page 59
Operating mode of the chairman units	To set the function of the selection key A (8) and B (9)	see page 65
Operating mode of the access point	To set the access point to stand-alone operation or integrated operation (slave mode) with SDC 8200	see page 60
Initialization mode of the conference units	To initialize the conference units on the access point	see page 56
Encryption mode	To set the encryption mode for radio transmission	see page 67

To switch the access point **off**:

- ▶ Set the on/off switch (53) to position "0".
The 3 status indicators (40) go off.

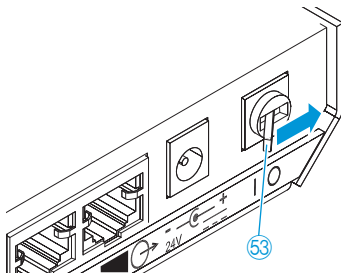

To **disconnect** the access point **from the mains**:

- ▶ Unplug the DC power supply from the wall socket.
The access point is completely switched off.

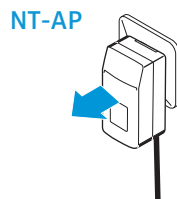

Switching a conference unit on/off

To switch a conference unit **on** :

- ▶ Press the microphone key ⑪.

The last configuration used is loaded.

The microphone LED ⑩ and the RF link indicator ③① display the connection status:

LED	Connection status with the access point
off: RF link indicator ③①, microphone LED ⑩	connection is established
flashes: RF link indicator ③①: blue microphone LED ⑩: red green	connection is being established
lights up: RF link indicator ③①: blue	malfunction

C CV D DV

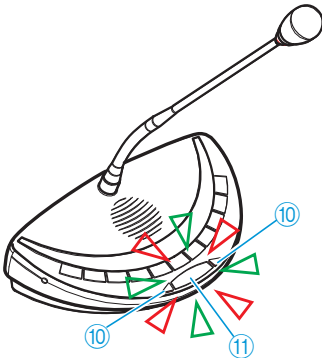

C CV D DV

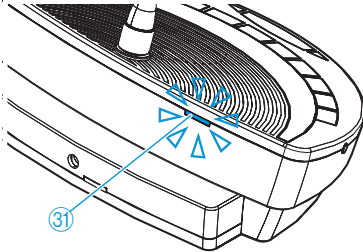

C CV D DV

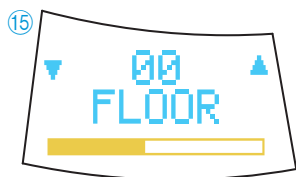
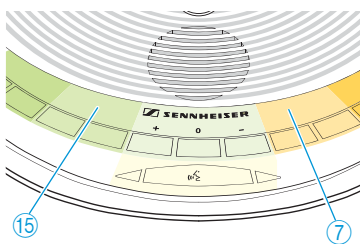

C CV D DV

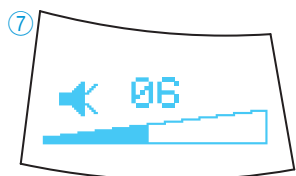

When the connection is established, the multi-function display ⑦ and the channel selection display ⑮ of the WiCOS DV and WiCOS CV conference units switch on.



If there are several access points within the transmission range, intermodulation can occur. In this case, use the dynamic frequency management (see page 52) and initialize the desired conference units on the access point (see page 76).

If no connection to an access point can be established within 2 minutes, the conference unit automatically switches off.

The following last used configurations are loaded. You can use the factory default settings or adapt the configuration to your needs (see page 43):

Configuration	Function/Meaning	Detailed information
Country settings for radio communication	To set country-specific limit values for radio frequencies and transmission power	see page 50
RF signal strength	To set the transmission power	see page 52
Radio frequency	To set the radio frequencies to be used in the 2.4 GHz and 5 GHz frequency bands	see page 52
Loudspeaker volume	To set the volume of the conference units' loudspeakers	see page 59
Operating mode of the chairman units	To set the function of the selection key A ⑧ and B ⑨	see page 65

Configuration	Function/Meaning	Detailed information
Setting the initialization mode of the conference units	To initialize the conference units on the access point	see page 56
Encryption mode	To set the encryption mode for radio transmission	see page 67

To manually switch a conference unit **off**:

- ▶ Press the microphone key **11** for 3 seconds.
The conference unit switches off. All LEDs and displays go off.

To automatically switch all conference units **off**:

- ▶ Switch the access point off (see page 29).
If there is no connection to an access point, the conference units will automatically switch off after 2 minutes.

To **completely** switch a conference unit **off** and disconnect it from the power supply:

- ▶ If necessary, unplug the charging power supply from the wall socket.

C CV D DV

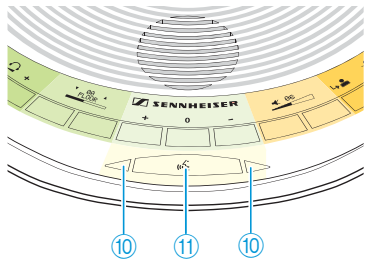

NT-BA

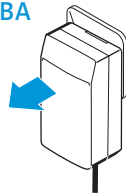

C CV D DV

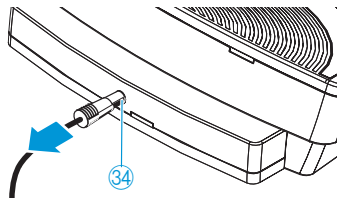

- ▶ Remove the battery pack from the conference unit (see page 27).

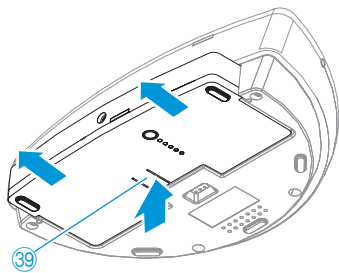

Running a conference

The character of your conference (i.e. the conditions under which the participants can take the floor, are assigned the "speaking right" or can listen to simultaneous interpretations) depends on the settings of the access point. You can adapt the conference system to your individual needs or use the factory default settings (see page 43).

Operating a delegate unit

The WiCOS D and WiCOS DV delegate units feature two headphone outputs and can therefore be used by one or two participants.

Taking the floor/Making a request to speak

Depending on the conference mode set (see page 58), you can

- take the floor immediately or
- make a request to speak.
You then have to wait until the chairman switches on your microphone.

If the conference mode is set so that you can take the floor immediately ("Direct Access" (factory default setting), "FIFO", "Override", "Group 1-4", see page 58):

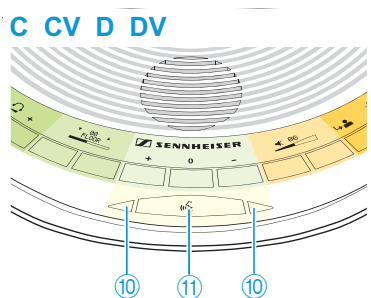

- ▶ Press the microphone key (11).
Your microphone switches on and you can take the floor immediately. The microphone LED (10) and the signal light ring (2) light up red. The loudspeaker (21) is muted. Depending on the conference mode and the speaker limit set, the microphone of the previous speaker will be switched off.

If the conference mode is set so that you first have to make a request to speak ("With request", "With request no clear", see page 58):

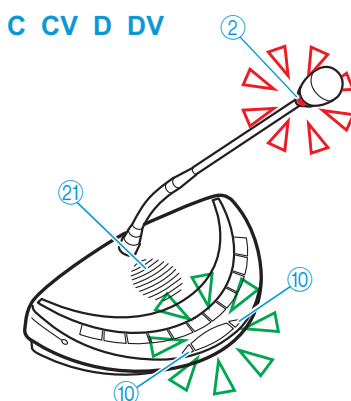

- ▶ Press the microphone key (11).
Your request to speak is added to the request-to-speak list. The microphone LED (10) flashes green and the signal light ring (2) flashes red.

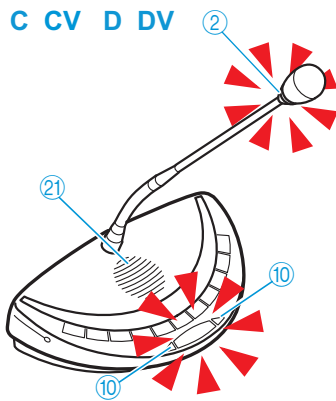

When the chairman assigns you the “speaking right”, your microphone switches on. The microphone LED ⑩ and the signal light ring ② light up red. The loudspeaker ⑳ is muted. Depending on the conference mode and the speaker limit set, the microphone of the previous speaker will be switched off.



With a chairman unit, you can take the floor at any time, without first having to be assigned the “speaking right”.

If you are only using delegate units, you can only choose conference modes where the “speaking right” does not have to be assigned by a chairman (“Direct Access” (factory default setting), “FIFO”, “Override”, “Group 1-4”, see page 58).

Switching the microphone off/Cancelling a request to speak

To switch off the microphone when you have finished speaking or to cancel a request to speak:

- ▶ Press the microphone key ⑪ once more. The microphone LED ⑩ and the signal light ring ② go off.

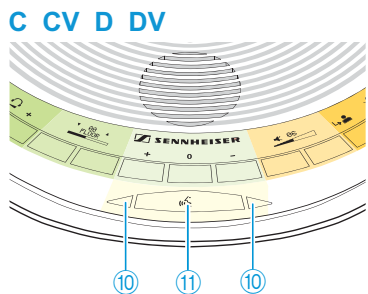

Participating in a voting session (WiCOS CV and WiCOS DV only)

You can participate in voting sessions which have to be started by the chairman (see page 38).

After the voting session has been started by the chairman, the LEDs of the voting keys ⑫, ⑬ and ⑭ flash.

- ▶ Press the corresponding key:
 - YES key ⑭: to vote “yes”
 - ABSTAIN key ⑬: to abstain from voting
 - NO key ⑫: to vote “no”

The LED next to the pressed voting key lights up permanently and your vote is counted.

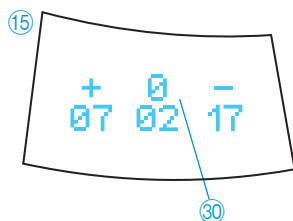
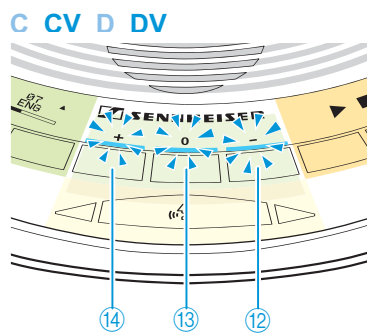

After the voting session has been stopped by the chairman (see page 38) the voting result ⑳ is shown on the channel selection display ⑮. The LED next to the pressed voting key goes off.

Connecting headphones (WiCOS CV and WiCOS DV only)

You can listen to the floor channel or the offered interpretation channels (where applies) via headphones (see next section).

C CV D DV

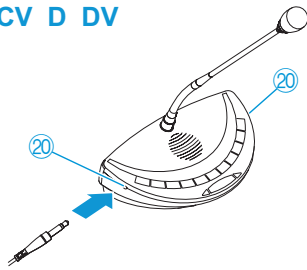

- ▶ Connect headphones with a 3.5 mm jack plug to one of the headphone sockets 20. You can connect mono or stereo headphones.

Listening to simultaneous interpretation (WiCOS CV and WiCOS DV only)

In order for you to be able to listen to a simultaneous interpretation of the floor channel via headphones, the conference system has to be connected to an interpretation system (see page 73).

- ▶ Ask the organizer on which channel your desired language is transmitted.
- ▶ Connect headphones to your conference unit (see above).
- ▶ Press the CHANNEL UP key 16 or the CHANNEL DOWN key 17 to select the desired interpretation channel. The selected interpretation channel is output via your headphones. The channel selection display 15 shows the currently set channel, e.g. "07 ENG" for channel 07 with interpretation into English (depending of the configuration of the interpretation system). If you select "00 FLOOR", the floor channel will be output (factory default setting).

C CV D DV

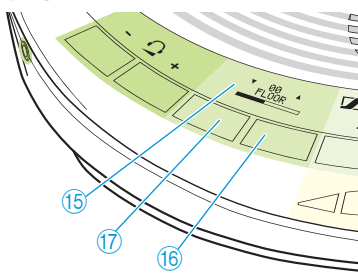

If the channel selection display 15 is showing a voting result, you can return to the channel display view by pressing the CHANNEL UP key 16 or the CHANNEL DOWN key 17. The voting result cannot be displayed again.

Adjusting the headphone volume

CAUTION! Hearing damage due to high volumes!



Listening at high volume levels for long periods can lead to permanent hearing defects.

- ▶ Before putting the headphones on, set the volume to a minimum level.
- ▶ Do not **continuously** expose yourself to high volumes.

- ▶ Put the headphones on.

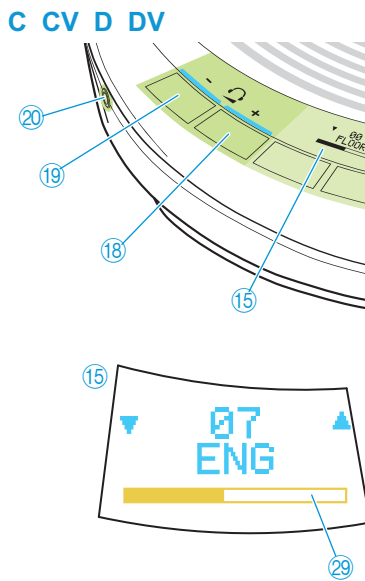

To adjust the volume:

- ▶ Press the headphone volume UP key (18) or the headphone volume DOWN key (19):
 "+" to increase the volume or
 "-" to reduce the volume.

The channel selection display (15) shows the volume on the headphone output (29). As long as you keep the key (18) or (19) pressed, the LED next to the key lights up.

If you switch the conference units off and on again (see page 31), the headphone volume is reset to a medium level.

With the WiCOS CV and WiCOS C conference units, the adjusted volume is common for both headphone sockets (20).



The volume of the conference units' loudspeakers can be adjusted via the web server of the access point (see page 59) or via the WiCOS CV or WiCOS C chairman unit (see page 40).

Operating a chairman unit

The chairman units have the same functions as the delegate units (see page 33).

You can

- take the floor,
- participate in a voting session,
- listen to simultaneous interpretations and
- use headphones.

A chairman unit allows you to take the floor at any time without having to "apply" for a comment. Active chairman units are not counted against the speaker limit.



In a conference system with several chairman units, all chairman units have the same rights.

The WiCOS C and WiCOS CV chairman units feature two headphone outputs and can therefore be used by one or two chairmen.

C CV D DV

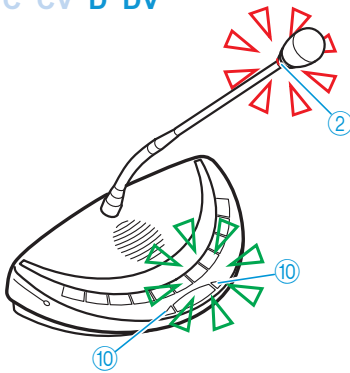

Assigning a participant the “speaking right”

If – in “With Request” or “With Req. No Clear” mode – a participant presses the microphone key on his conference unit, he makes a request to speak. All participants who have made a request to speak will join a request-to-speak list. On the conference unit, the microphone LED (10) flashes green and the signal light ring (2) flashes red, indicating that the participant has made a request to speak.

To assign the “speaking right” to the next participant from the request-to-speak list using the WiCOS C and WiCOS CV chairman units:

C CV D DV

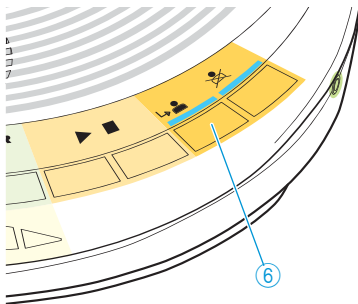

- ▶ Press the NEXT key (6).

The next participant from the request-to-speak list is assigned the “speaking right”. As long as you keep the key (6) pressed, the LED next to the key lights up.



In stand-alone operation, the “speaking right” can only be assigned using the WiCOS CV and WiCOS C chairman units. Conference control via the web server is not possible.

Ending a discussion

Using the cancel function, the chairman can end a discussion at any time.

C CV D DV

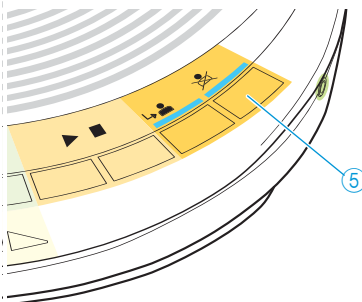

- ▶ Briefly press the priority key (5).

All conference units are muted. The request-to-speak list is not cleared. As long as you keep the key (5) pressed, the LED next to the key lights up.

Muting all delegate units temporarily

Using the priority function, the chairman can interrupt a discussion at any time.

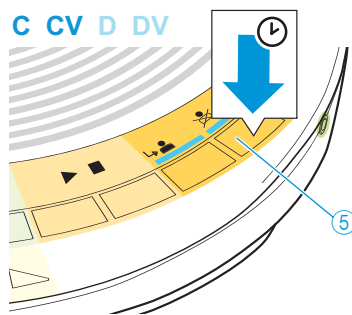

- ▶ Keep the priority key ⑤ pressed for as long as you want to mute the conference units (push-to-mute function). All conference units – except for the chairman units – are muted. The microphone LED ⑩ and the signal light ring ② of the previously active conference units flash red. As long as you keep the key ⑤ pressed, the LED next to the key lights up.

To take the floor while keeping the priority key pressed:

- ▶ Press the microphone key ⑪ (see page 33).



The “speaking right” of your chairman unit remains active, even if you cancel the conference or mute the conference units.

To cancel the muting of the conference units:

- ▶ Release the priority key ⑤. The muting of the conference units is canceled. The LED next to the key ⑤ goes off. The discussion is continued.

Starting a voting session

With the WiCOS C and WiCOS CV chairman unit with voting function, you can start, pause and stop a voting session.

CAUTION! Danger of loss of the voting result!

The voting results are not saved.

- ▶ Note down the voting results.
- ▶ Use the voting functions of the SDC 8200 conference and interpretation system, which allows you to save voting results (see page 73 and the instruction manual of the SDC 8200 conference and interpretation system).

If you are using the **WiCOS CV** chairman unit, you have to proceed as follows.

To **start** a voting session:

- ▶ Keep the ABSTAIN key ⑬ pressed until the “voting mode” is shown on the multi-function display ⑦. The multi-function display switches between “voting mode”, “volume adjustment mode for loudspeakers” and “media control mode”.



You can also switch between the operating modes using the web server (see page 65).

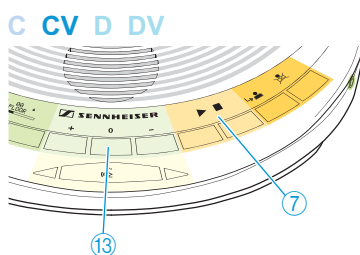

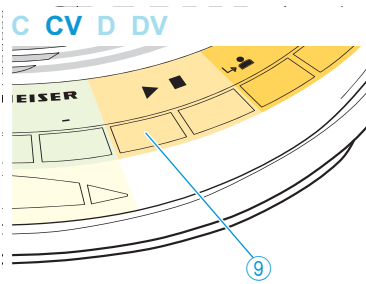

▶ Press the selection key B ⑨.

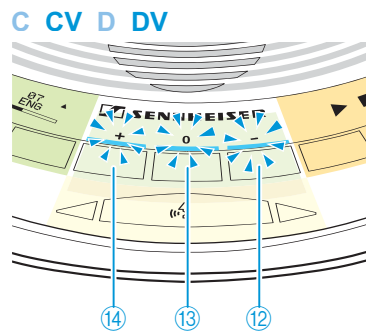

With the WiCOS DV and WiCOS CV conference units, the LEDs next to the keys ⑫, ⑬ and ⑭ light up. The participants can cast their vote (see page 34).

To **end** or **cancel** the voting session:

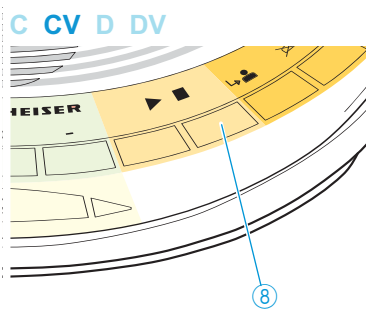

▶ Press the selection key A ⑧.

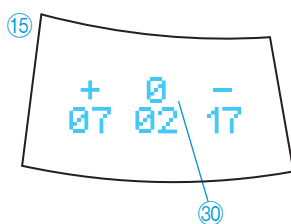

The voting session is stopped. The LEDs next to the keys ⑫, ⑬ and ⑭ go off. The voting result ③① is shown on the channel selection displays ⑮ of the conference units.

To **clear** the voting result:

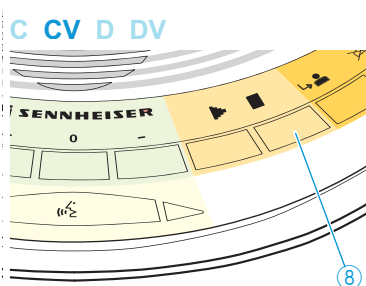

▶ Press the selection key A ⑧.

The voting result ③① on the channel selection display ⑮ is cleared and the display changes to the interpretation channel view.

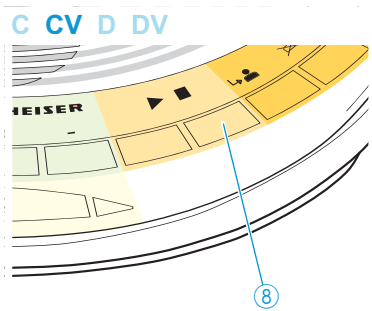

To **start** a **new** voting session:

- ▶ Press the selection key A (8).
The voting result (30) on the channel selection display (15) is cleared and the display changes to the interpretation channel view.

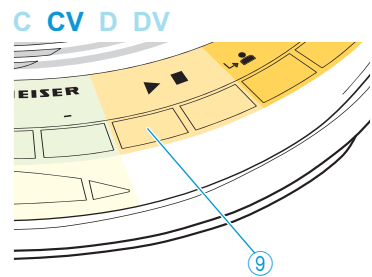

- ▶ Press the selection key B (9).
A new voting session is started.

If you are using the **WiCOS C** chairman unit, the set operating mode of the conference unit and the voting result cannot be displayed. You can nevertheless conduct voting session.

- ▶ Via the web server, set the function of the selection key A (8) and B (9) to “**Start/Stop Voting**” (see page 65).
- ▶ Start or stop voting session and delete voting results using the selection key A (8) and B (9) (for more information, see page 38).
As long as you keep the key (8) or (9) pressed, the LEDs next to the keys light up.

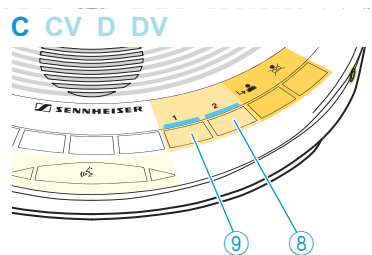

i With the **WiCOS C** chairman unit, you cannot participate in the voting session yourself.

Setting the volume of the conference units' loudspeakers

With the **WiCOS CV** or **WiCOS C** chairman units, you can set the loudspeaker volume of all conference units.

If you are using the **WiCOS CV** chairman unit:

- ▶ Keep the **ABSTAIN** key (13) pressed until the “volume adjustment mode for loudspeakers” is shown on the multi-function display (7).
The multi-function display switches between “voting mode”, “volume adjustment mode for loudspeakers” and “media control mode”.

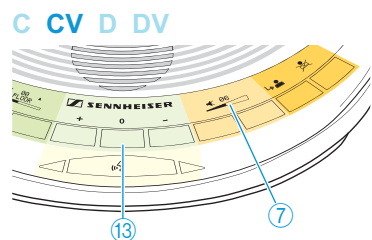

i You can also switch between the operating modes using the web server (see page 65).

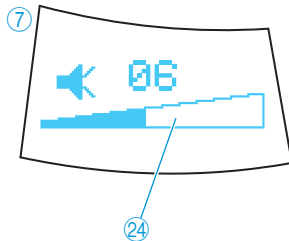
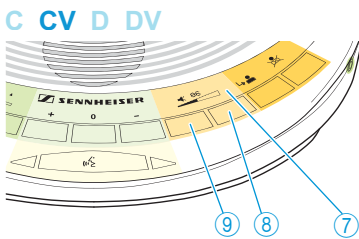

- ▶ Press the
 - selection key A (8) to increase the loudspeaker volume or
 - selection key B (9) to reduce the loudspeaker volume.

The loudspeaker volume is changed. The multi-function display (7) shows the volume of the conference units' loudspeakers (24).

If you are using the **WiCOS C** chairman unit:

- ▶ Via the web server, set the function of the selection key A (8) and B (9) to "Volume Control" (see page 65)

- ▶ Press the
 - selection key A (8) to increase the loudspeaker volume or
 - selection key B (9) to reduce the loudspeaker volume.

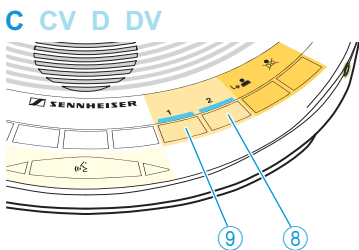

The loudspeaker volume is changed. As long as you keep the key (8) or (9) pressed, the LED next to the key lights up.



The volume of the conference units' loudspeakers can also be adjusted via the web server of the access point (see page 59).

Activating the media control mode

In the future, the WiCOS C and WiCOS CV chairman units will allow you to transmit commands to a media control system, for example in order to trigger circuits via a home controller. The corresponding commands can be programmed via the web server of the access point.

If you are using the **WiCOS CV** chairman unit, activate the media control mode as follows (e.g. to start or stop a camera system):

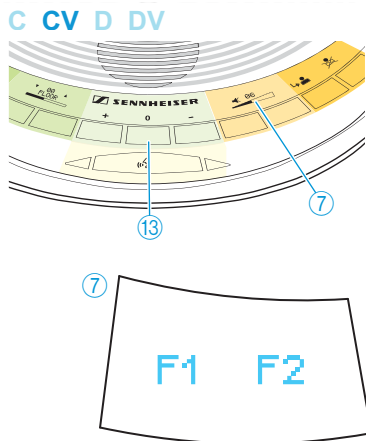

- ▶ Keep the ABSTAIN key (13) pressed until the "media control mode" is shown on the multi-function display (7). The multi-function display switches between "voting mode", "volume adjustment mode for loudspeakers" and "media control mode".



You can also switch between the operating modes using the web server (see page 65).

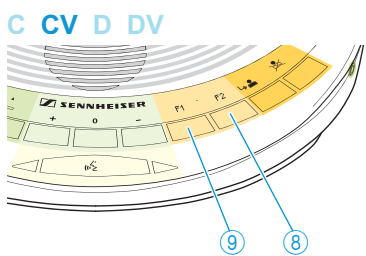

- ▶ Press the selection key A (8) or the selection key B (9) to trigger circuits via a home controller. Depending on the setting, pressing key (8) or (9) transmits a start signal or a stop signal.

If you are using the **WiCOS C** chairman unit:

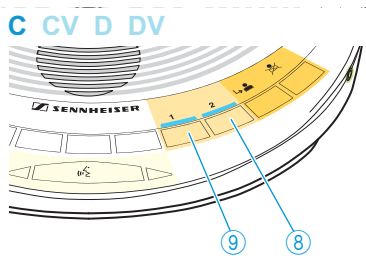

- ▶ Via the web server, set the function of the selection key A (8) and B (9) to "Function key" (see page 65).
- ▶ Press the selection key A (8) or the selection key B (9) to trigger circuits via a home controller. Depending on the setting, pressing key (8) or (9) transmits a start signal or a stop signal. As long as you keep the key (8) or (9) pressed, the LED next to the key lights up.

Configuring the conference system



If you change the factory default settings via the web server, the last settings used are loaded on a restart of the conference system.

Loading the factory default settings – “Reset”

CAUTION! Loss of settings!

If you reset the access point and the conference units to the factory default settings, custom settings are discarded.

▶ Before resetting the devices, note down the settings used.

To reset the access point and the conference units to the factory default settings:

- ▶ If necessary, unplug connected system cables and network cables from the IN system socket (RJ 45) ⑤①, the OUT system socket (RJ 45) ⑤② and the network socket (RJ 45) ④⑧.

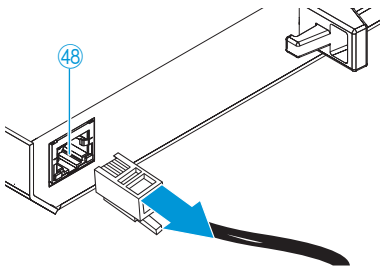
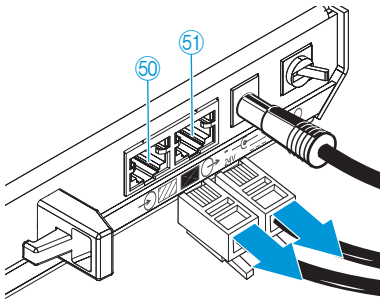

- ▶ Switch the access point on (see page 29).
- ▶ Switch on all the conference units that you want to reset to the factory default settings (see page 31).
- ▶ Use a pointed object (e.g. straightened paper clip) to press the reset key ④② on the access point for approx. 5 seconds. The 3 status indicators ④① of the access point flash while you press the reset key. All indicators and displays on the conference units light up. The access point and the conference units are reset to the factory default settings. The status indicators ④① of the access point and the indicators and displays on the conference units go off once resetting is completed. The conference units are initialized with the access point.

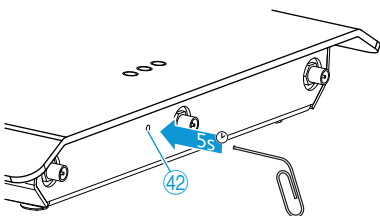

After the reset, the following factory default settings are loaded:

Configuration	Factory default setting
Network settings (IP address)	System name: "WiCOS" IP address mode: "Static" IP: "192.168.0.10" Subnet: "255.255.255.0"
Password protection	"123"
RF signal strength ("Room size")	"Big"
Radio frequency	"Automatically"
Country settings for radio communication ("Country selection")	"US/Canada"
Max. number of simultaneously active microphones	"4"
Conference mode	"Direct Access"
Loudspeaker volume	"6"
Number of interpretation channels	"0"
Operating mode of the chairman units WiCOS C and WiCOS CV	"Volume Control"
Operating mode of the access point	"Stand Alone"
Initialization mode of the conference units	"Open Access"
Encryption mode	"Use default key"

Calling up the web server of the access point

In order to be able to call up the web server of the access point, you require a computer with network connection (RJ 45) and a web browser.

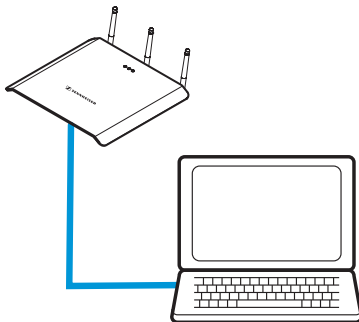

- ▶ Make sure that the access point is correctly connected to your computer or network via the network socket (RJ 45) ⁴⁸.

Setting the computer to the address range of the access point

In order to access the web server the first time, you have to set your computer to the address range of the access point.



You only require the fixed IP address of your computer in order to access the web server for the first time. Via the web server, you can adapt the IP address of the access point to match the ones in your network.

Microsoft Windows XP operating system

If you are using [Microsoft Windows XP](#), proceed as follows in order to set a static IP address (see also the instruction manual of the operating system):

- ▶ Click "Start" and select "Control Panel".
The "Control Panel" window opens.

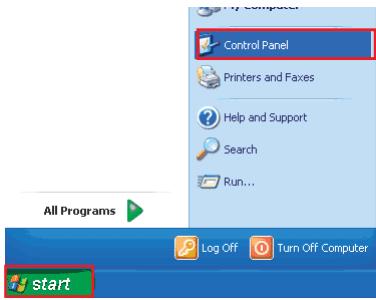

- ▶ Click "Network Connections"
A list of all the network connections on the computer appears.

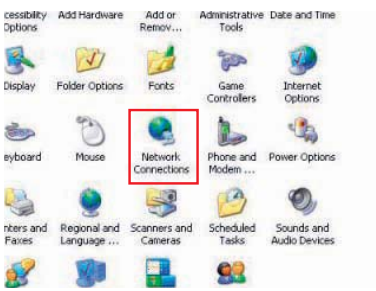

- ▶ Right-click "Local Area Connection".
A shortcut menu appears.
- ▶ On the shortcut menu, click "Properties".
The "Local Area Connection Properties" window appears.

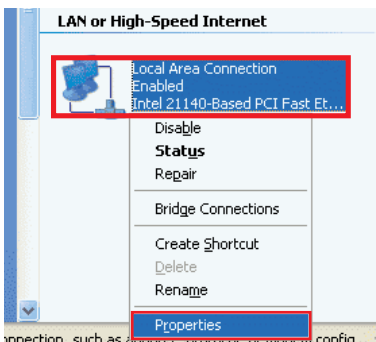

- ▶ Select "Internet Protocol (TCP/IP)" and click the "Properties" button.
The "Internet Protocol (TCP/IP) Properties" window appears.

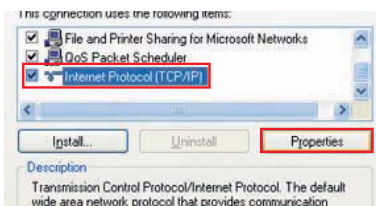

- ▶ Click the "Use the following IP address" option button.
- ▶ In the "IP address" field, type your desired IP address, e.g. 192.168.0.12.
- ▶ In the "Subnet mask" field, type the subnet mask 255.255.255.0.
Both addresses have to be within the address range of the access point.

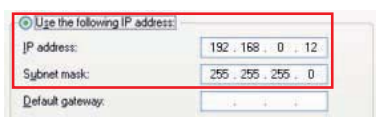

Do **not** use the IP address of the access point: 192.168.0.10.

- ▶ Confirm your entries by clicking "OK".

Apple MacOS X operating system

If you are using **Apple MacOS X**, proceed as follows in order to set a static IP address (see also the instruction manual of the operating system):

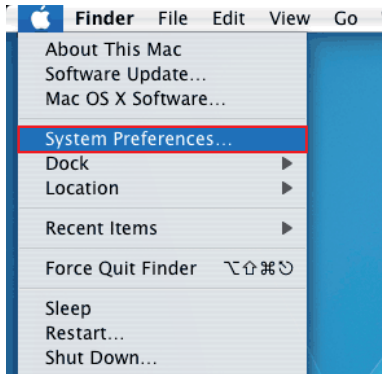

- ▶ Click the "Apple" icon and select "System Preferences".
The "System Preferences" window opens.



- ▶ Click "Network".
The "Network" window opens.

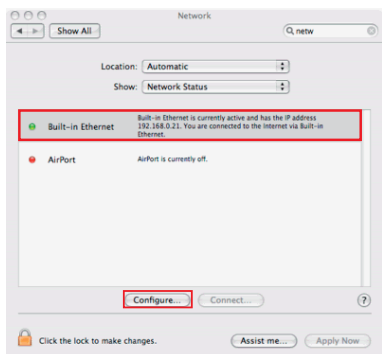

- ▶ From the "Show" drop-down list, select "Built-in Ethernet".
- ▶ Click "Configure...".
The "Built-in Ethernet" window opens.

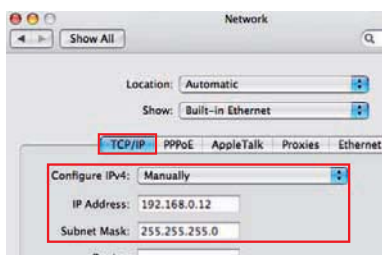

- ▶ From the "Configure IPv4" drop-down list, select "Manually".
- ▶ In the "IP address" field, type your desired IP address, e.g. 192.168.0.12.
- ▶ In the "Subnet mask" field, type the subnet mask 255.255.255.0.
Both addresses have to be within the address range of the access point.



Do **not** use the IP address of the access point: 192.168.0.10.

- ▶ Confirm your entries by clicking "Apply now".

Accessing the access point (overview screen)



Make sure the network communication between access point and computer is not blocked by a proxy server and/or a firewall.

- ▶ Switch the access point on (see page 29).
- ▶ Start a web browser (e.g. Internet Explorer or Firefox).
- ▶ In the address box of the browser, type the IP address of the access point: the factory default IP address 192.168.0.10 or your adapted IP address.
- ▶ Press the Enter key or click the “Refresh” button of your web browser. The web server appears in the browser window and prompts for a password.

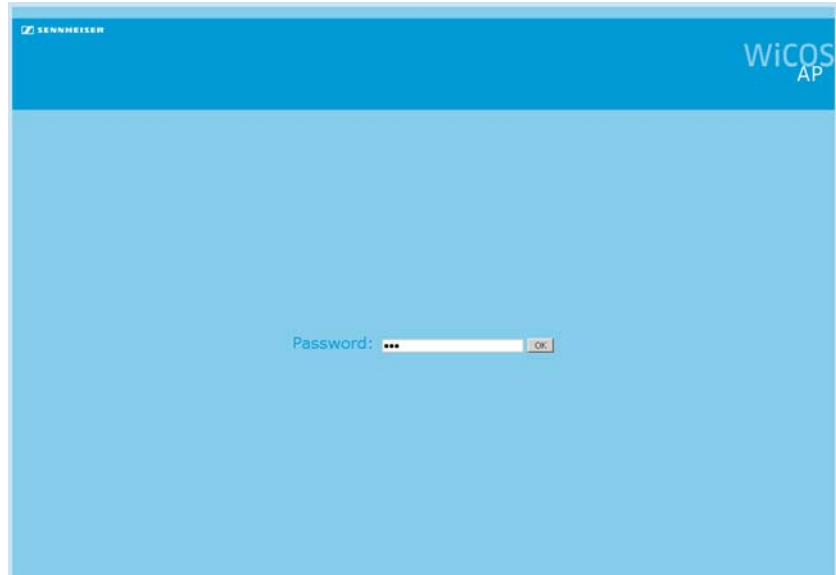

If you have not assigned a password:

- ▶ Type the default password “123” into the entry field.
- ▶ Click “OK”.
The “Summary” overview screen of the web server appears.

If you have assigned a password (see page 51):

- ▶ Type the password into the entry field.
- ▶ Click “OK”.
The “Summary” overview screen of the web server appears.



If you have forgotten the password, you can reset the access point to the factory default settings in order to be able to access the web server (see page 43).

Attention: If the access point is reset, any custom settings will be lost!

Adjusting the basic settings – “Setup”

Overview screen – “Summary”

The overview screen provides information on the system settings (“System Information”) and the device settings (“Device Information”), e.g. for servicing purposes.

- ▶ In the main navigation, click “Setup”.
The “Summary” overview screen appears.



Setting	Function/Meaning	Additional information
“System Name”	User selectable name for the network address of the conference system	see page 48
“IP Address”	IP address of the access point	
“Subnet Mask”	Subnet address of the address point	
“Address Mode”	Address mode of the network address	
“Base MAC Address”	MAC address of the access point	
“Serial Number”	Serial number of the access point	see page 67
“Model Name”	Model name of the access point	
“Hardware Version”	Version number of the hardware	
“Boot Version”	Version number of the boot firmware	
“Firmware Version”	Version number of the firmware	
“FPGA Version”	Version number of the conference units' firmware	
“RF Hardware 1 Version”	Version number of the transmission hardware	
“RF Hardware 2 Version”	Version number of the reception hardware	
“RF Firmware 1 Version”	Version number of the transmission firmware	
“RF Firmware 2 Version”	Version number of the reception firmware	

Setting the network address of the access point – “TCP/IP Settings”

The fixed IP address 192.168.0.10 and the subnet address 255.255.255.0 are factory preset. Using this address, you can access the web server.

There are two ways to integrate the access point into the network and to use the web server. You can

- integrate the access point into a network with static IP addresses or
- integrate the access point into a network with DHCP.

To call up the IP address settings:

- ▶ In the main navigation, click “Setup” > “TCP/IP Settings”. The “TCP/IP Settings” overview screen appears.

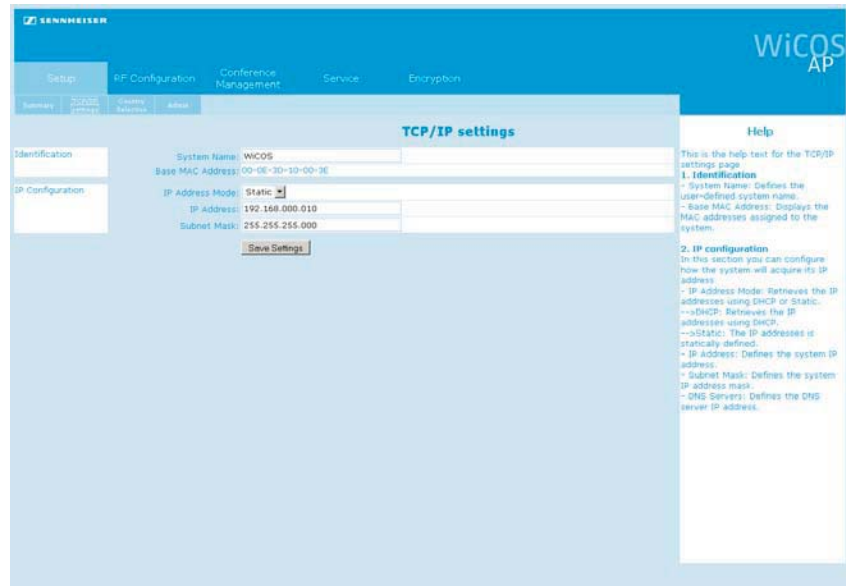

To set an unique **network identification** of the access point:

- ▶ In the “System Name” field, type a name for your conference system.

To use a **dynamic IP address** – “DHCP”:

- ▶ From the “IP Address Mode” drop-down list, select “DHCP”. The access point automatically obtains its IP address from a server. In order to be able to use this function, you need a DHCP server in your network that automatically assigns IP addresses.

To use a **static IP address** – “Static”:

- ▶ From the “IP Address Mode” drop-down list, select “Static”.
- ▶ In the “IP Address” field, type the desired IP address.
- ▶ In the “Subnet Mask” field, type the desired subnet mask.



Make sure that this IP address is not used in your network.

- ▶ Note down the IP address so that you can call up the web server again.
-
- ▶ Click “Save settings”. The settings are saved.
 - ▶ Switch the access point off and on again (see page 29). You can now access the web server via the new IP address.
 - ▶ In the address box of the browser, type the new IP address of the access point.
 - ▶ Press the Enter key. The web server appears in the browser window.



If you have forgotten the new IP address, you can reset the access point to the factory default settings in order to be able to access the web server (see page 43).

Attention: If the access point is reset, any custom settings will be lost!



If you want to integrate the access point into a managed network in which only selected devices are allowed to be integrated, you have to assign your router or switch the MAC address of the access point. You can find this MAC address on the “[Summary](#)” overview screen (see page 47).

Setting the country-specific limit values – “Country selection”

To set the conference system to the country-specific limit values for radio systems:

CAUTION! Risk of violation of legal requirements!

If you are using radio frequencies and transmission powers that cannot be used license-free in your country, there is a risk of violation of legal requirements.

- ▶ Use only radio frequencies and transmission powers that are approved and legal in your country.
- ▶ From the “[Country selection](#)” drop-down list, select the correct country in which the conference system is to be used.

- ▶ In the main navigation, click “[Setup](#)” > “[Country selection](#)”. The “[Country selection](#)” overview screen appears.

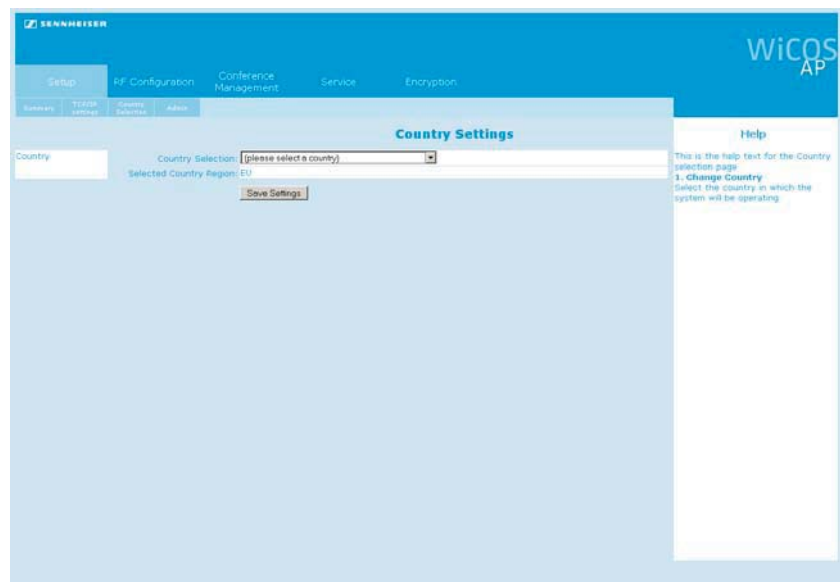

- ▶ From the “[Country selection](#)” drop-down list, select the country in which the conference system is to be used.
- ▶ Click “[Save settings](#)”. The settings are saved. The selected country is displayed in the “[Selected Country Region](#)” field. The conference system will only use

frequencies and transmission powers that are approved and legal in the selected country/region.



The country-specific radio settings for the United States and Canada, "US/Canada", are the most restricted radio settings in the conference system. These settings are used as the factory default settings.

Setting the password protection – "Admin"

You can protect the access point against unauthorized access and changes to the system by setting a password. The factory default setting is no password.

- ▶ In the main navigation, click "Setup" > "Admin".
The "Admin: authentication" overview screen appears.

The screenshot shows the Sennheiser WiCOS AP Admin interface. The main navigation includes Setup, RF Configuration, Conference Management, Service, and Encryption. The 'Admin' section is active, showing the 'Admin: authentication' page. The 'Change password' section has three input fields: 'Old Password', 'New Password', and 'Confirm New Password', each with a 'Show/Hide' toggle. A 'Save Settings' button is located below the fields. A 'Help' section on the right provides instructions for changing the password and a note about the old password.

- ▶ In the "Old password" field, type the old password.
If you want to use the factory default settings, leave the field blank.
- ▶ In the "New password" and "Confirm new password" fields, type the new password.
The password can consist of a maximum of 50 characters.
- ▶ Click "Save settings".
The new password is saved. The next time you switch the access point on, access to the web server is password protected.



If you reset the access point to the factory default settings, the password is "123".

For safety settings for encryption of the radio transmission, refer to the chapter "Eavesdropping protection and encryption – "Encryption"" on page 67.

Adjusting the RF settings – “RF configuration”

Setting the RF signal strength – “General”

The RF signal strength of the conference system can be set in two different ways:

- automatic setting of the RF signal strength (recommended)
- manual setting of the RF signal strength

- ▶ In the main navigation, click “RF Configuration”. The “General RF settings” overview screen appears.

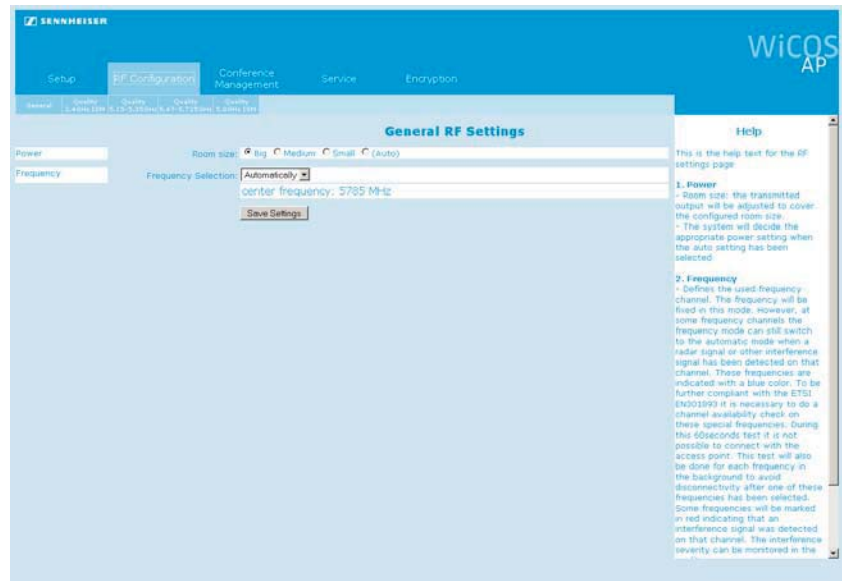

To set the RF signal strength to **automatic mode**:

- ▶ In the “Room size” box, select the “(Auto)” option button.
- ▶ Click “Save settings”. The setting is saved. The RF signal strength is automatically adapted to the operating conditions/room size.

To **manually** set the RF signal strength:

- ▶ In the “Room size” box, select the appropriate option button:

Option button	RF signal strength	Area of application
“Big”	maximum RF signal strength	large rooms of approx. 3000 m ²
“Medium”	medium RF signal strength	medium sized rooms of approx. 2000 m ²
“Small”	low RF signal strength	small rooms of approx. 1000 m ²

- ▶ Click “Save settings”. The setting is saved. The RF signal strength is set to the selected power.

Setting the frequencies – “General”

The frequency selection of the conference system can be set in two different ways:

- automatic frequency selection ([dynamic frequency management](#); recommended)
- manual frequency selection

The WiCOS conference system is factory preset to dynamic frequency management. This function automatically detects occupied frequency bands and switches to an unused frequency band, thus allowing for interruption-free operation and parallel use of the WiCOS conference system with other wireless conference systems, WLAN routers and other radio networks.

The maximum number of access points you can use simultaneously varies depending on the frequency range. If you want to use several conference systems in parallel, we recommend careful frequency planning in order to avoid mutual intermodulation between channels working in close proximity.

- ▶ Have the system scan the available frequency ranges (see page 54).
- ▶ Set a fixed available frequency (see page 52).

Frequency range	Max. number of access points	Minimum distance between access points
2.4 GHz	3	1.5 m
5.7-5.8 GHz	8	1.5 m
5.1-5.7 GHz	14	1.5 m



The scan of the available frequency ranges can take up to 60 seconds. This time is needed if the 2.4 GHz frequencies are occupied and the 5 GHz frequencies have to be scanned.

During scanning, conferencing is **not** possible.

- ▶ In the main navigation, click “[RF Configuration](#)”.
- The “[General RF settings](#)” overview screen appears.

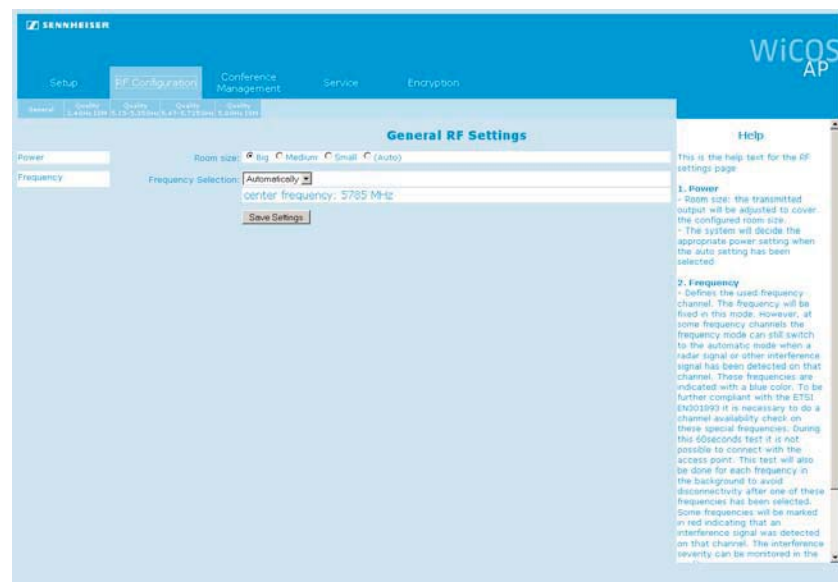

To set the frequency selection to automatic mode ([dynamic frequency management](#)):

- ▶ From the “[Frequency Selection](#)” drop-down list, select “[Automatically](#)”.

- ▶ Click **“Save settings”**.
The setting is saved. The conference system automatically selects the frequencies and switches to alternate frequencies if intermodulation occurs.

To **manually set** a frequency range:

CAUTION! Danger of intermodulation!

If the automatic frequency management is deactivated, the radio signals of the conference system and the radio signals of other devices can be subject to intermodulation.

- ▶ Make sure that the manually set frequency ranges are not used by other devices and are not subject to intermodulate (see **“Monitoring the frequency ranges – “Quality””** on page 54).
- ▶ Use the dynamic frequency management.

To select an unused frequency range, use the frequency range monitoring function which displays occupied and unused frequency ranges (see page 54).

- ▶ From the **“Frequency Selection”** drop-down list, select an unused frequency:

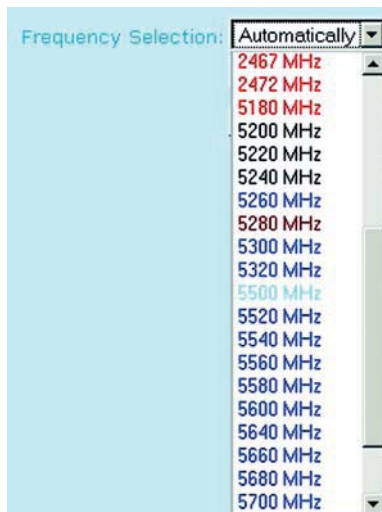

Color identification	Frequencies are ...	Function/Restriction
black	unused	You can use these frequencies.
blue	currently unused These frequencies can be used by other devices (e.g. radar equipment)	You can use these frequencies. If intermodulation occurs, the system switches to alternate frequencies.
light blue	occasionally used by other devices (e.g. radar equipment)	You can currently use these frequencies.
red	currently used by other devices (e.g. WLAN equipment)	You should not use these frequencies.
dark red	occasionally used by other devices (e.g. radar equipment)	You cannot use these frequencies.

The selected frequency is shown under the drop-down list.

- ▶ Click **“Save settings”**.
The setting is saved. The conference system uses the selected frequency.

Monitoring the frequency ranges – “Quality”

The frequency range monitoring function displays occupied and unused frequency bands.

- ▶ In the main navigation, click **“RF Configuration”**.
The **“General RF settings”** overview screen appears.

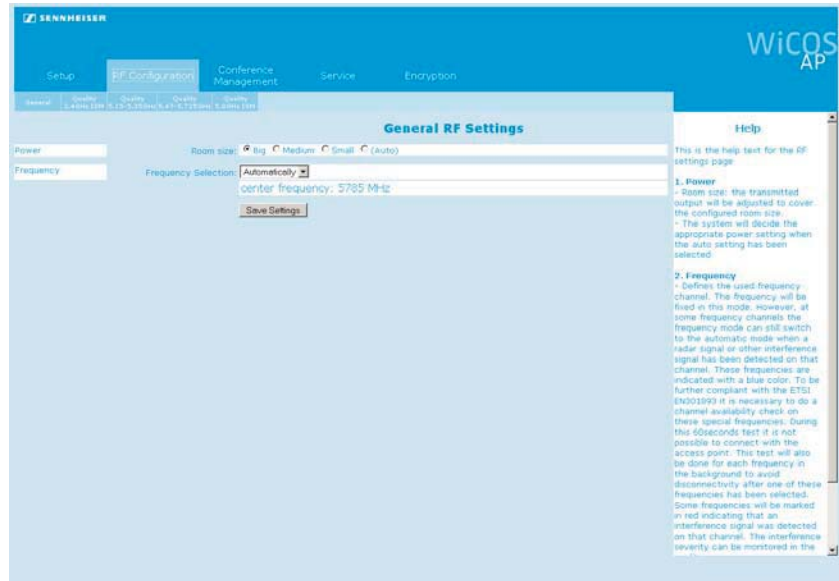

- ▶ Select the overview screen of the desired frequency range:
 - “Quality 2.4 GHz ISM”
 - “Quality 5.15-5.35 GHz”
 - “Quality 5.47-5.725 GHz”
 - “Quality 5.8 GHz ISM”

A bar chart of the selected frequency range is displayed. The colored bars indicate the currently occupied and/or unused frequencies. The red deflections indicate the amount of radio traffic.



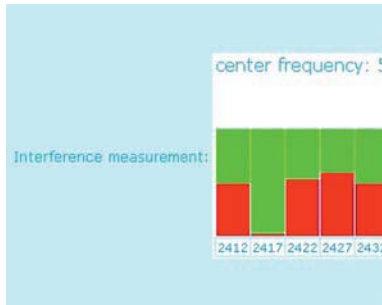

Color of bar	Radio traffic
green	No radio traffic on the corresponding frequency: Your conference system should use this frequency.
red	Heavy radio traffic on the corresponding frequency: Your conference system should not use this frequency.

i If you have manually set your conference system to a frequency range, it might be that the frequency range monitoring displays the radio traffic of the set frequency range that is used by the conference system itself.

This does not impair the operation of the conference system.

Adjusting the conference settings – “Conference Management”

i If you have integrated the WiCOS conference system into the wired SDC 8200 conference and interpretation system, the conference settings can be configured via the central unit of the wired system (see page 70 and the instruction manual of the SDC 8200 conference and interpretation system).

Setting the maximum number of simultaneously active microphones (speaker limit)

The speaker limit determines the maximum number of speakers who can take the floor simultaneously. In the conference modes “FIFO” and “Group 1-4”, the speaker limit is preset to a fixed value.

i If you set a high number of interpretation channels, the speaker limit will be reduced.

- ▶ Reduce the number of interpretations channels in order to be able to set the speaker limit to a maximum of 8 (see “Setting the number of interpretation channels” on page 59).

- ▶ In the main navigation, click “Conference management”. The “General Conference Settings” overview screen appears.

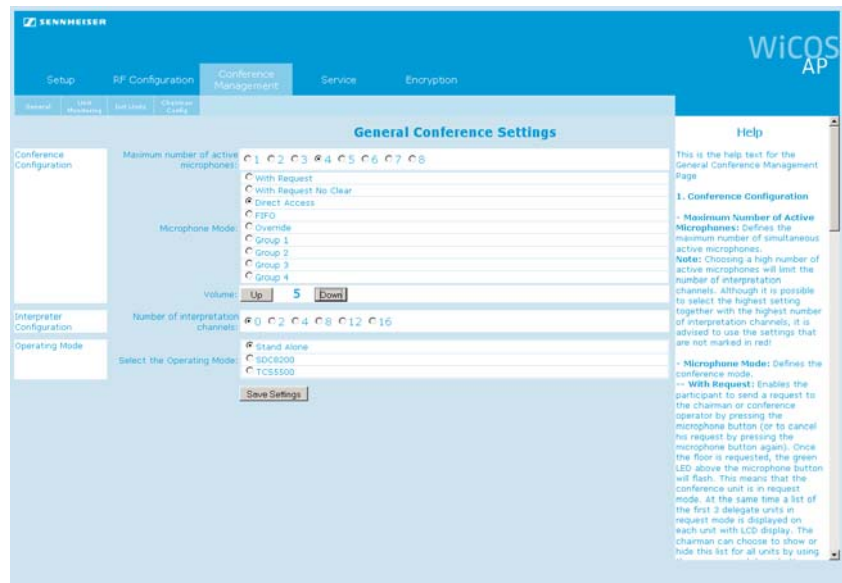

- ▶ In the “Maximum number of active microphones” box, select the desired option button.
The number of simultaneously active microphones can be between “1” and “8”.
- ▶ Click “Save settings”.
The setting is saved. The speaker limit is set to the selected value.



Regardless of the conference mode and speaker limit set, the following applies:

- With a chairman unity you can take the floor immediately without first having to be assigned the “speaking right”.
- Active chairman units are not counted against the speaker limit.

Setting the conference mode

The WICOS conference system offers different conference modes, allowing you to tailor a conference to your needs.

- ▶ In the main navigation, click “Conference management”.
The “General Conference Settings” overview screen appears.

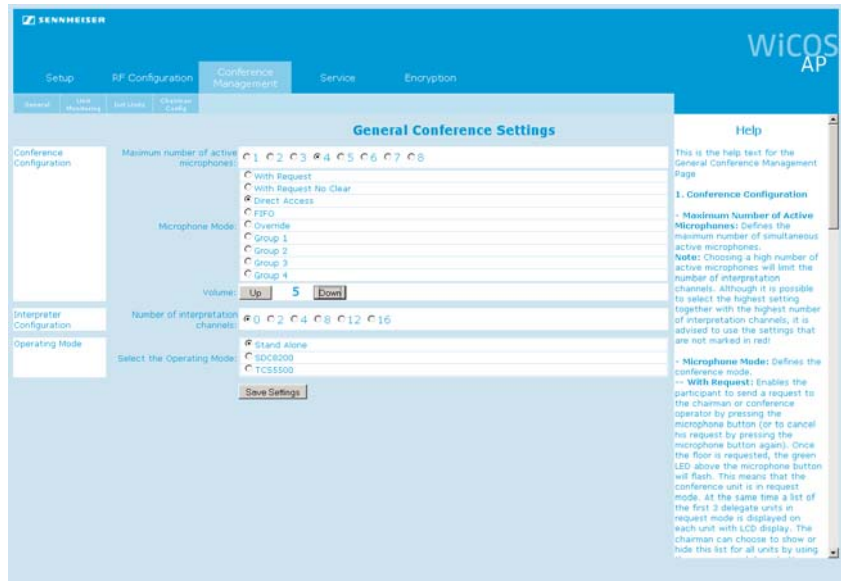

- ▶ In the “Microphone Mode” box, select the desired option button. Refer to the table below for more information on the individual conference modes.
- ▶ Click “Save settings”. The setting is saved. The conference system is set to the selected conference mode.

Conference mode	Speaker limit	By pressing the microphone key ⑪ ...	Chairman unit	Cancellation of a request to speak
“With request”	1 to 8	... you make a request to speak and join the request-to-speak list. You can only take the floor after you have been assigned the “speaking right”.	required – assigns the “speaking right”	possible
“With request no clear”				not possible
“Direct access” (factory default setting)	1 to 8 (factory default setting: 4)	... you can take the floor immediately – provided that the speaker limit has not yet been reached. If the speaker limit has been reached, you have to wait until one of the current speakers has finished speaking.	not required	–
“FIFO”	1	... you can take the floor immediately. The microphone of the previous speaker is switched off.	not required	–
“Override”	1 to 8	... you can take the floor immediately. The microphone of the speaker who is speaking for the longest time is switched off.	not required	–

Conference mode	Speaker limit	By pressing the microphone key Ⓜ ...	Chairman unit	Cancellation of a request to speak
"Group 1"	1 you can take the floor immediately – provided that the speaker limit has not yet been reached.	not required	possible
"Group 2"	2			
"Group 3"	3			
"Group 4"	4	If the speaker limit has been reached, you will join the request-to-speak list. You will automatically be assigned the "speaking right" as soon as another speaker has finished speaking.		

Setting the volume of the conference units' built-in loudspeakers

- ▶ In the main navigation, click "Conference management". The "General Conference Settings" overview screen appears.

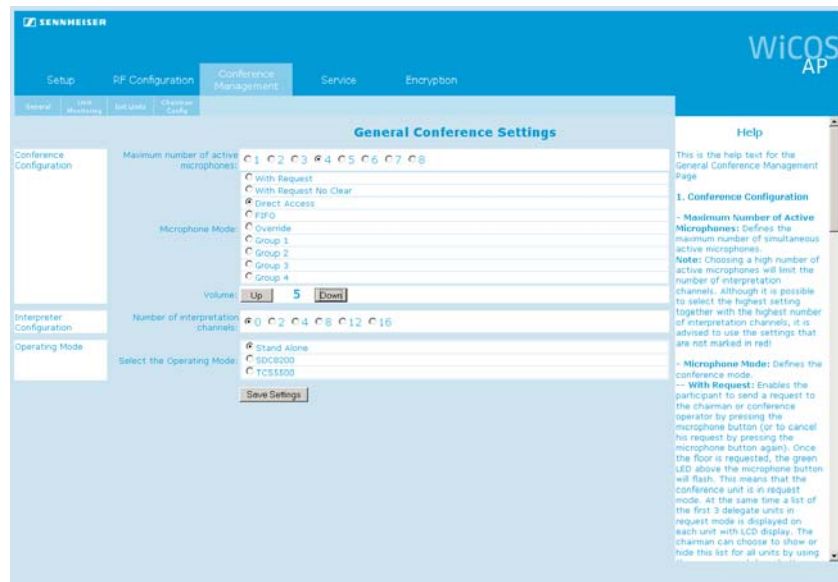

- ▶ in the "Volume" box, click the "Up" or the "Down" button.
 - "0" = off
 - "1" = low
 - "12" = very high

The selected volume level is displayed between the two buttons.
- ▶ Click "Save settings".
The setting is saved. The loudspeaker volume is set to the selected level.



The volume of the conference units' loudspeakers can also be set via the WICOS CV or WICOS C chairman unit (see page 40).

Setting the number of interpretation channels

- ▶ In the main navigation, click "Conference management". The "General Conference Settings" overview screen appears.

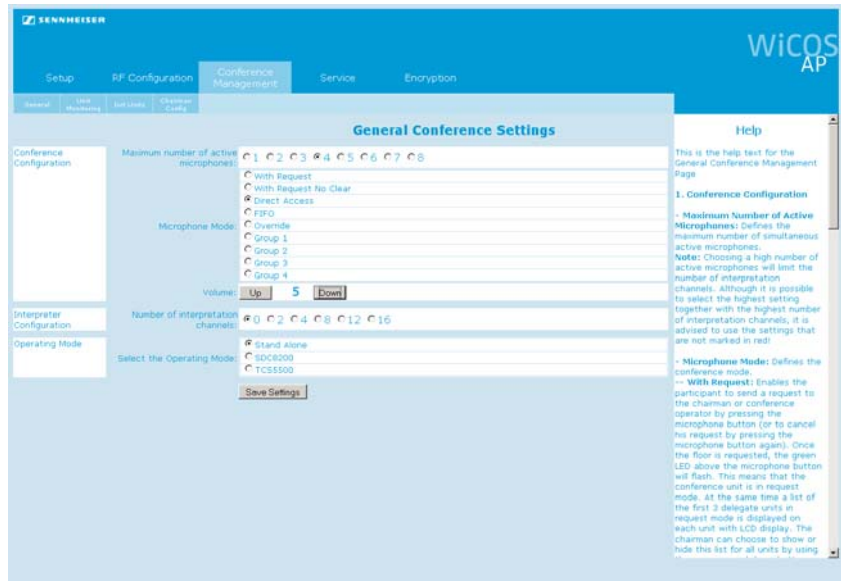

- ▶ In the “**Number of interpretation channels**” box, click the desired option button.
You can offer “0”, “2”, “4”, “8”, “12” or “16” interpretation channels.
- ▶ Click “**Save settings**”.
The setting is saved. The maximum number of interpretation channels is set (see also “Using the interpretation system” on page 79). If necessary, the maximum number of simultaneously active microphones (speaker limit) will be reduced (see page 56). Values that can no longer be selected will be displayed in red in the “**Maximum number of active microphones**” box.

Setting the operating mode of the access point

The access point is suitable for stand-alone operation or can be integrated into a wired SDC 8200 conference and interpretation system (slave mode operation).

- ▶ In the main navigation, click “**Conference management**”.
The “**General Conference Settings**” overview screen appears.

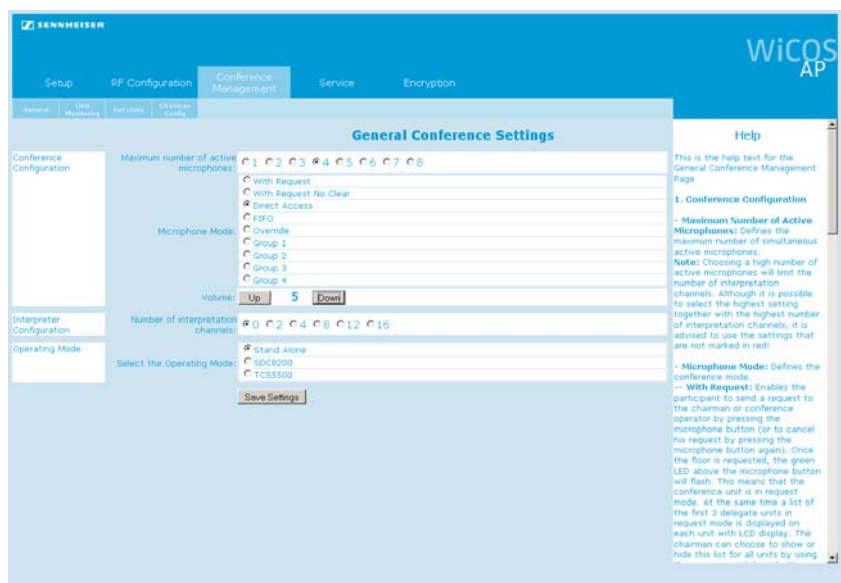

- ▶ In the “Select the Operating Mode” box, select the “Stand Alone”, “SDC 8200” or the “TCS 5500” option button.

Setting	Operating mode of the access point
“Stand Alone”	Stand-alone operation
“SDC 8200”	Integrated operation (slave mode operation)
“TCS 5500”	The WiCOS conference system is integrated into a wired conference and interpretation system and operates in slave mode (see page 73 and the instruction manual of the SDC 8200 or TCS 5500 system).

- ▶ Click “Save settings”.
The setting is saved. The access point is set to the desired operating mode.

The status indicator 40 provides information on the operating mode:

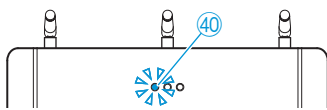

Blue LED 1 ...	Operating mode of the access point
flashes slowly	Integrated operation (slave mode)
lights up	Stand-alone operation

Monitoring initialized conference units – “Unit monitoring”

- ▶ In the main navigation, click “Conference management” > “Unit monitoring”.
The “Unit monitoring” overview screen is displayed.

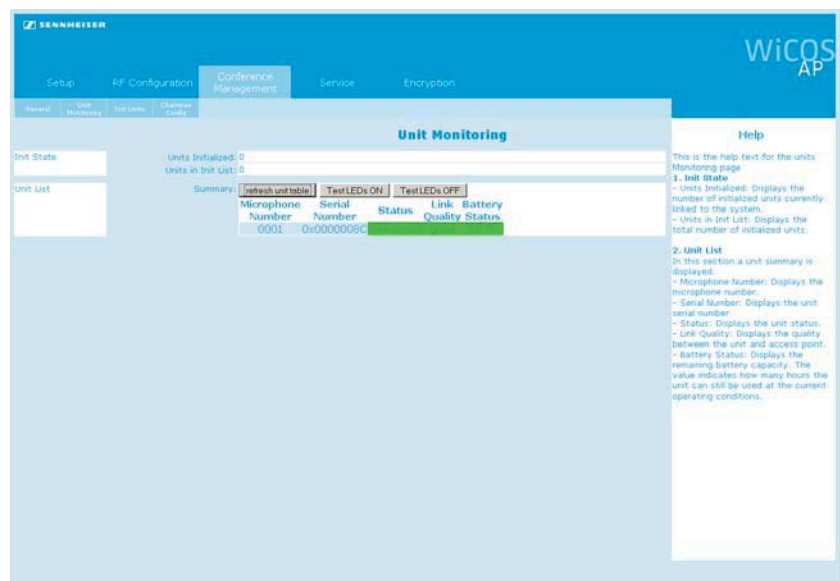

The following information on the initialized conference units is displayed:

Information	Function/Meaning
“Units initialized”	Number of conference units that are initialized with the access point and currently switched on
“Units in init list”	Number of conference units that are manually initialized with the access point
“Microphone Number”	4-digit microphone number
“Serial Number”	Serial number of the conference unit

Information	Function/Meaning
"Status"	Connection status between access point and conference units: <ul style="list-style-type: none"> • "Connected" • "Disconnected"
"Link Quality"	Link quality between access point and conference units: <ul style="list-style-type: none"> • "Excellent" • "Good" • "Fair" • "Low"
"Battery Status"	Remaining operating time in hours

The information on the conference units is not automatically refreshed.

To refresh the information:

- ▶ Click "[Refresh Unit Table](#)",
The information is refreshed.

To clearly identify the conference units initialized with the system:

- ▶ Click "[Test LEDs ON](#)".
The indicators and displays of the initialized conference units light up.

To switch the test mode off:

- ▶ Click "[Test LEDs OFF](#)".
The indicators and displays of the initialized conference units go off.

Initializing the conference units with the access point – "Init Units"

There are two ways to initialize the conference units with the access point:

- automatic initialization – "[Open access](#)"
- manual initialization – "[Manual](#)" (recommended when operating several WiCOS conference systems simultaneously and/or conference systems with encryption)
- ▶ In the main navigation, click "[Conference management](#)" > "[Init units](#)".
The "[Init units](#)" overview screen appears.

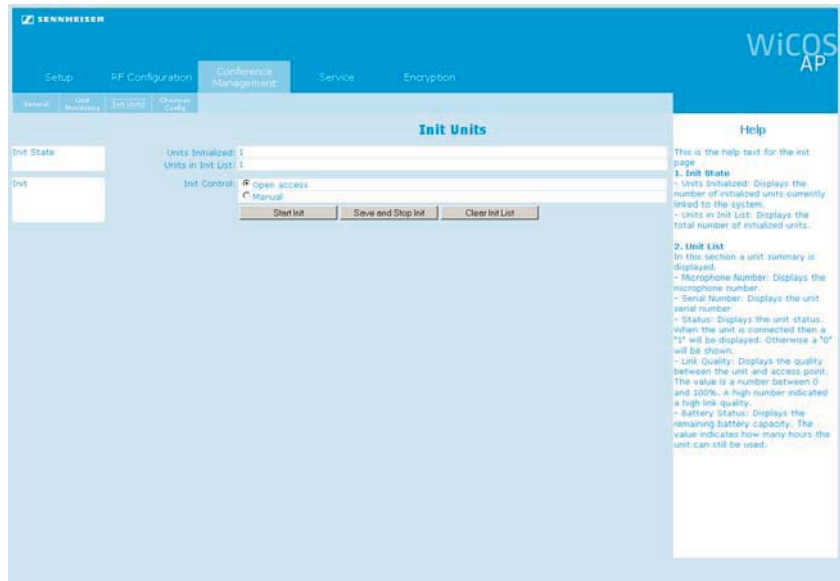

The following information is displayed:

Information	Function/Meaning
“Units initialized”	Number of conference units that are initialized with the access point and currently switched on
“Units in Init List”	Number of conference units that are manually initialized with the access point

To **automatically initialize** all conference units within the transmission range of the access point:

- ▶ In the “Init Control” box, select the “Open Access” option button. If you switch on a conference unit that is within the transmission range of the access point, the conference unit is automatically integrated into the conferences system. This conference unit is listed under “Units Initialized” and “Unit monitoring”.

CAUTION! Intermodulations in conferences!

If you operate several conference systems simultaneously in “Open Access” mode, this will cause intermodulations as the conference units will communicate with different access points.

- ▶ Initialize the conference units manually (see next section).

To **manually initialize** certain conference units with the access point:

- ▶ Switch on all conference units that you want to use in your conference system (see page 31).
- ▶ In the “Init Control” box, select the “Manual” option button.
- ▶ Click “Clear Init List”. The existing “Units in Init List” list will be deleted (where applies).
- ▶ Click “Start init”.

C CV D DV

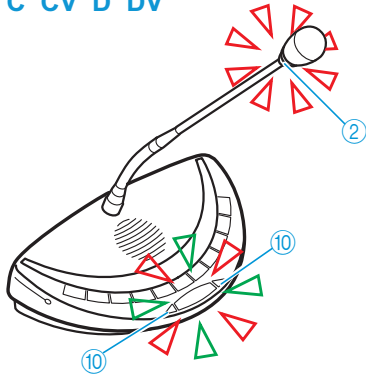

The initialization process starts. All conference units that are operational show a microphone LED ⑩ flashing green and red and a signal light ring ② flashing red.

C CV D DV

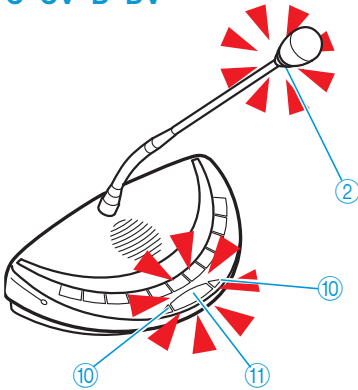

- ▶ Press the microphone key ⑪ of the conference unit that you want to initialize.

The microphone LED ⑩ and the signal light ring ② go off. The conference unit is initialized and listed in the "Units in Init List". The conference units are assigned microphone numbers in the order of initialization. These microphone numbers allow you to clearly identify the conference units.

- ▶ Repeat these steps for all conference units that you want to initialize.



Make sure that no conference units are initialized unintentionally.

- ▶ Use the "Unit Monitoring" function to check that only "wanted" conference units are initialized (see page 61).

- ▶ Click "Save and Stop Init".

The initialization process is stopped. The initialized conference units are saved in the "Units in Init List". The microphone LED ⑩ and the signal light ring ② go off.

When the conference system is switched on the next time, only the conference units listed in the "Units in Init List" will be used for conferencing.



In order to increase the safety of your conference system, you can individually adjust the encryption of the radio communication (see "Eavesdropping protection and encryption – "Encryption"" on page 67).

Setting the operating mode/functions of the selection keys A and B – “Chairman Config”

You can assign different operating modes and functions to the selection keys A (8) and B (9) of the WiCOS C and WiCOS CV chairman units.

- ▶ In the main navigation, click “Conference Management” > “Chairman Config”.

The “Chairman Configuration Settings” overview screen appears.

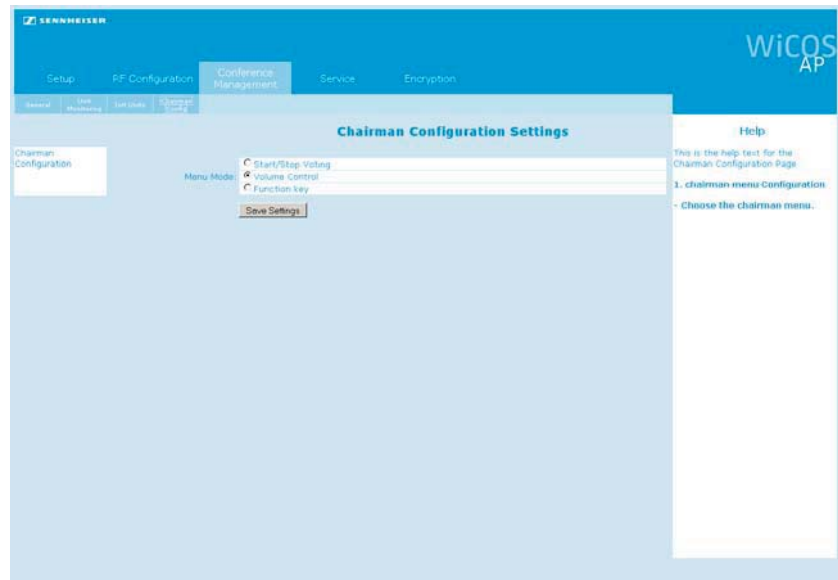
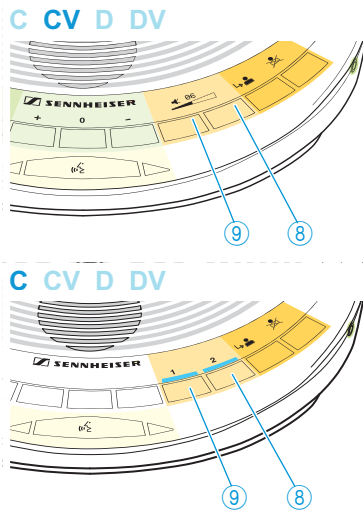

- ▶ In the “Menu Mode” box, select the desired option button:

Option button	Mode	Function
“Start/Stop Voting”	Voting mode	<ul style="list-style-type: none"> • Selection key A (8) starts a voting session • Selection key B (9) stops a voting session
“Volume Control”	Volume adjustment mode for loudspeakers	<ul style="list-style-type: none"> • Selection key A (8) increases the volume • Selection key B (9) reduces the volume
“Function key”	Media control mode	<ul style="list-style-type: none"> • Selection key A (8) controls external media devices • Selection key B (9) controls external media devices

- ▶ Click “Save settings”.

The setting is saved. The selection keys A (8) and B (9) of the WiCOS C and WiCOS CV chairman units are assigned the desired function/operating mode. With the WiCOS CV chairman unit, the multi-function display (7) displays the operating mode set.



With the WiCOS CV chairman unit, you can also set the operating modes directly on the device (see page 15).

Additional functions – “Service”

Logging function

The access point logs various operating procedures. This function is primarily used as a diagnostic aid for troubleshooting.

- ▶ In the main navigation, click “Service”.
The “Logging” overview screen appears.

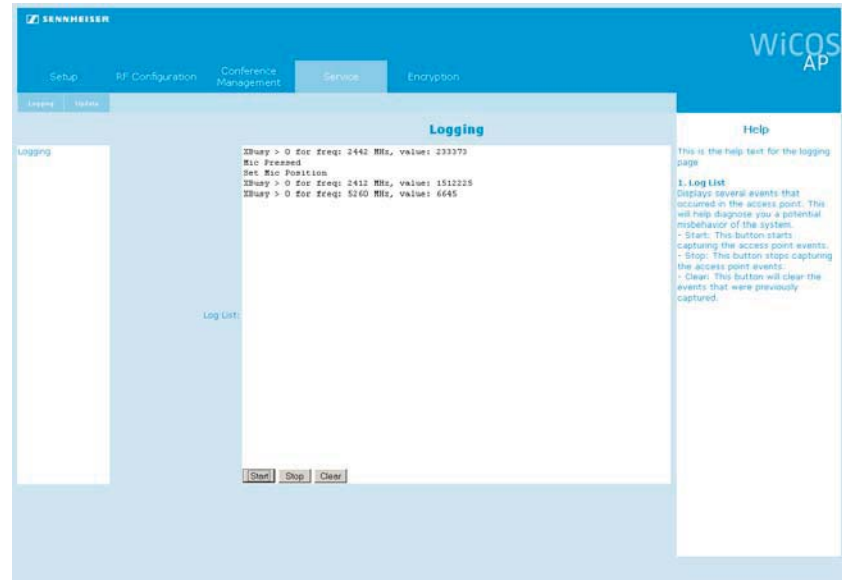

To **start** the logging:

- ▶ Click “Start”.
The logging starts.

To **stop** the logging:

- ▶ Click “Stop”.
The logging stops.

To **save** the log entries:

- ▶ Highlight the log entries.
- ▶ Cut and paste the log entries into your word processing program.

To **delete** the log entries:

- ▶ Click “Clear”.
The log entries are deleted.



The logging function does not log the voting results.

Updating the firmware of the access point and the conference units – “Update”

CAUTION! Danger of damage to the access point and the conference units!

Improper modification of the firmware (e.g. due to updates) can cause irreparable damage to the access point and the conference units.

- ▶ Only update the firmware if the function of your conference system is impaired or if the update is recommended by Sennheiser.
- ▶ Make sure that you use the correct update file.
- ▶ Follow the instructions given in the service information.
- ▶ While the update is in process, do not disconnect the access point and the conference units from the power supply.

For information on firmware updates for your WiCOS conference system, contact your Sennheiser partner or visit the download area of our website at www.sennheiser.com. There you will also find detailed service information on how to update the firmware.

Eavesdropping protection and encryption – “Encryption”

All radio signals in the conference system are automatically encrypted via a 128-bit algorithm. This function prevents that the signals can be eavesdropped upon.

There are two ways to use encryption:

- automatic encryption via default encryption (“Use default key”)
 - custom encryption for using the conference system in encryption-protected operation and adapting it to your requirements
- ▶ In the main navigation, click “Encryption”.
The “Key assignment” overview screen appears.

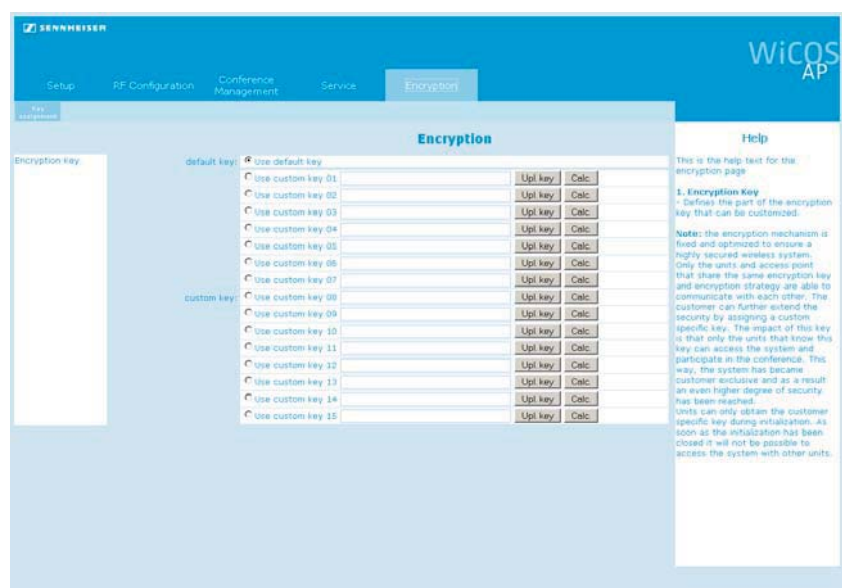

Using default encryption

- ▶ In the “default key” box, select the “Use default key” option button. The setting is saved. The system encrypts all radio signals with the default encryption key. All components of the WiCOS series can communicate with each other using this encryption key.



If you select the default encryption “default key”, you can use all WiCOS conference units without restrictions.

Using custom encryption

To use custom encryption and protect the system against unauthorized access by further WiCOS conference units:

- ▶ Initialize all required conference units with the access point (see page 62).
- ▶ If necessary, use the “Unit monitoring” function to check that only “wanted” conference units are initialized (see page 61).
- ▶ In the “custom key” box, select one of the “Use custom key ...” option buttons.
- ▶ Generate an encryption key by clicking “Calc.” (“Calculate”). An arbitrary key is generated in the corresponding “Use custom key ...” field. The key is saved in this field.

Or:

- ▶ Enter a custom key into one of the “Use custom key ...” fields. The key must consist of 32 hexadecimal characters. You can use
 - numbers from 0 to 9 and
 - letters from A to F.

If you enter a key shorter than 32 characters, the missing characters will be filled in with zeros. If you enter a key longer than 32 characters, the exceeding characters will be dropped. The entered key is saved in the corresponding “Use custom key ...” field.

To assign the custom encryption key to the currently initialized conference units:

- ▶ Click “Upl. key” (“Upload key”). A safety query appears.
- ▶ Click “OK” to assign the custom encryption key to the initialized conference units. The custom encryption key is transferred to all currently initialized conference units. During the transfer, the microphone LED ⑩ and the signal light ring ② of the conference units flash red. You can use the current conference configuration again the next time you switch the conference system on.



Only switched-on conference units that have been assigned the custom encryption key can be used in the encryption-protected conference configuration.

To **add** a conference unit to a conference configuration that uses custom encryption:

- ▶ Initialize all required conference units with the access point (see page 62).

- ▶ Assign these conference units the desired custom key as described on page 68.

To **no longer use** a custom key:

- ▶ Initialize all required conference units with the access point (see page 62).
- ▶ In the “**default key**” box, select the “**Use default key**” option button. The setting is saved. The system encrypts all radio signals with the default encryption key. The access point can now use all WiCOS conference units again.



Automatic encryption and individual encryption both have an identical encryption algorithm. The custom key allows you to adapt the conference system to your requirements and protect it against unauthorized access.

To **delete** a custom key:

- ▶ In the “**custom key**” box, select the custom key to be deleted by clicking the corresponding “**Use custom key ...**” option button.
- ▶ Press the Delete key to delete the selected custom key.

Or:

- ▶ Overwrite the selected custom key with a new custom key.

Using previously saved custom encryption keys

The conference units and the access point can manage up to 15 custom encryption keys. This allows you to specify which conference units are admitted to the conference.

- ▶ In the “**custom key**” box, select one of custom keys by clicking the corresponding “**Use custom key ...**” option button. All conference units that have been assigned this custom key can be linked to the access point and can be used for the conference configuration.



Note down which custom key “**Custom key ...**” is used by which conference configuration. Also note down the custom keys. The software does not save the custom keys as text, i.e. they cannot be restored.

Transporting the conference system

One of the advantages of the WiCOS wireless conference system is that it is easy to set up and dismantle again. This makes the conference system mobile and ensures flexibility of use.

Preparing the access point for transport

- ▶ Switch the access point off (see page 29).
- ▶ Unplug the DC power supply from the wall socket.
- ▶ If necessary, disconnect any cables connected to the access point.

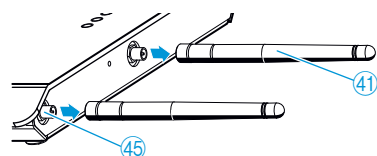
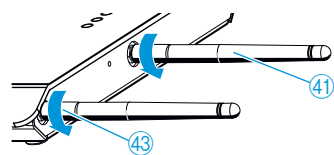
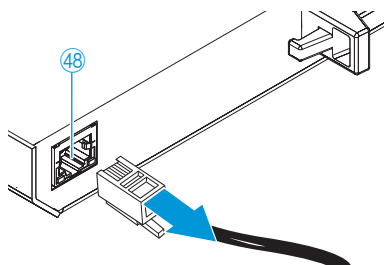
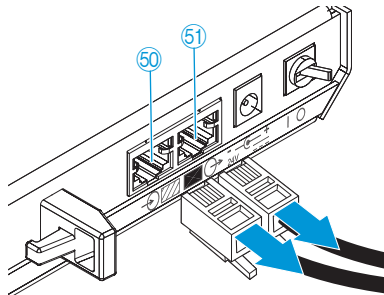
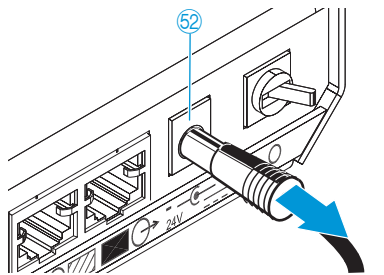

- ▶ Remove the 3 antennas (41) by unscrewing the coupling rings (43) and carefully pulling the antennas out of the antenna sockets (45).

- ▶ Pack the individual components of the access point up safely. Make sure that the components are protected against shocks and humidity.

Preparing the conference units for transport

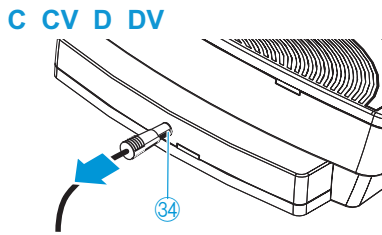

- ▶ If necessary, unplug the charging power supply from the wall socket
- ▶ Unplug the connector from the socket for charging power supply.

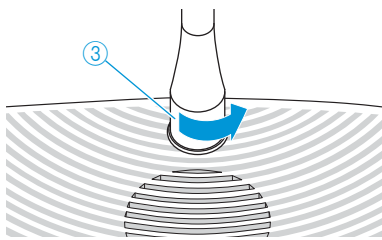

- ▶ If necessary, disconnect any headphones connected to the conference unit.
- ▶ Unscrew the coupling ring ③ of the gooseneck microphone.

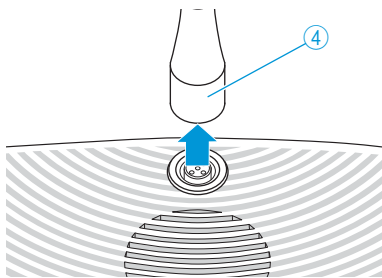

- ▶ Carefully pull the gooseneck microphone out of the microphone socket ④.

CAUTION! Risk of short-circuiting and fire!



If the Lithium-Ion battery pack is transported or stored incorrectly, it can short-circuit and catch fire.

- ▶ Make sure that the battery pack cannot come into contact with small electrically conducting parts or liquids.
- ▶ Wrap the battery pack individually in material which does not conduct electricity.



We recommend removing the battery pack from the conference unit for transport or storage (see page 27).

- ▶ Pack the individual components of the conference unit up safely. Make sure that the components are protected against shocks and humidity.

Using the transport case

For transporting the conference system, we recommend WiCOS CASE, an optionally available transport case on wheels. This case has padded compartments for an access point, 12 conference units and the microphones. It also allows you to pack and transport the power supply units and other accessories safely.

To pack the transport case:

- ▶ Prepare the access point and the conference units for transport (see page 70).
- ▶ Insert the access point into the access point holder 68.

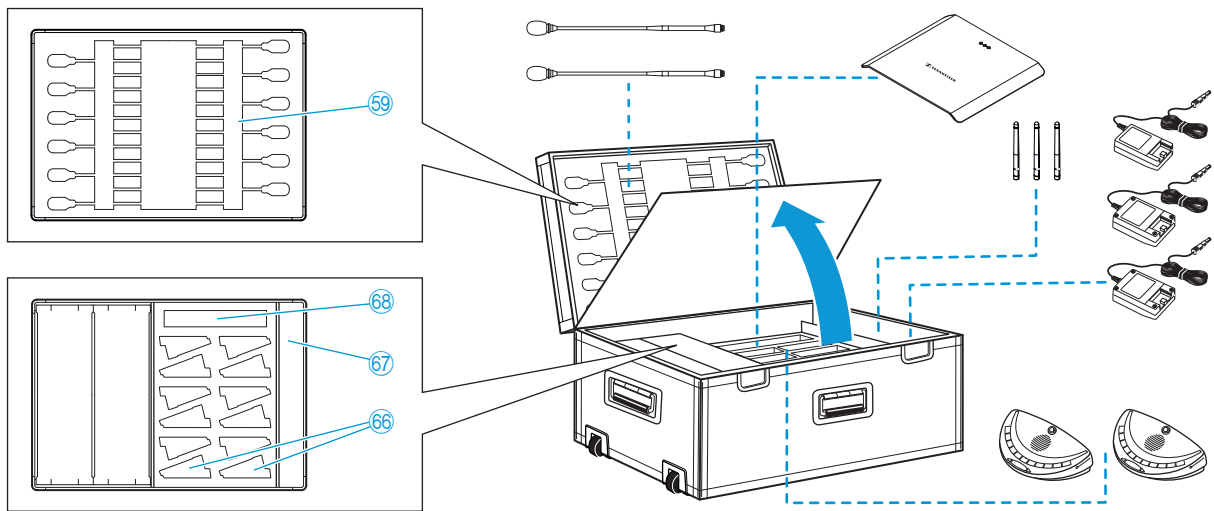

- ▶ Insert the conference units with the battery packs into the conference unit holder 66.
- ▶ Insert the gooseneck microphones into the microphone holder 59.
- ▶ Pack the accessories such as antennas, cables or power supply units into the compartment 67.
The conference system is securely packed and protected against shocks, dust and humidity.

To use the telescopic handle:

- ▶ Slide the catch 62 to the right and pull out the telescopic handle 61.
- ▶ Transport the case carefully.

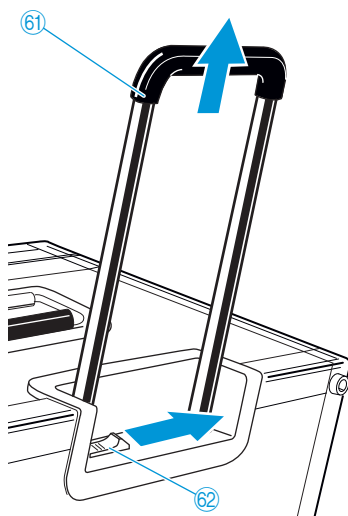

Integrating WiCOS into a wired conference system

You can integrate the WiCOS wireless conference system into the wired SDC 8200 conference and interpretation system.

The advantages of integrated operation (slave mode operation) are as follows:

- the wired SDC 8200 conference and interpretation system is easy to expand using the conference units of the WiCOS series, which are wireless and can be placed as you wish
- the WiCOS conference units are fully compatible with the SDC 8200 CU-M and SDC 8200 CU central units
- all conference modes and voting functions can be used (“yes”, “no” and “abstain”)
- language distribution with up to 16 interpretation channels

In addition, you can integrate the WiCOS wireless conference system into the wired Televic TCS 5500 conference and interpretation system. For more information, refer to the instruction manual of the TCS 5500 system.

Set up for integrated operation
(slave mode operation)

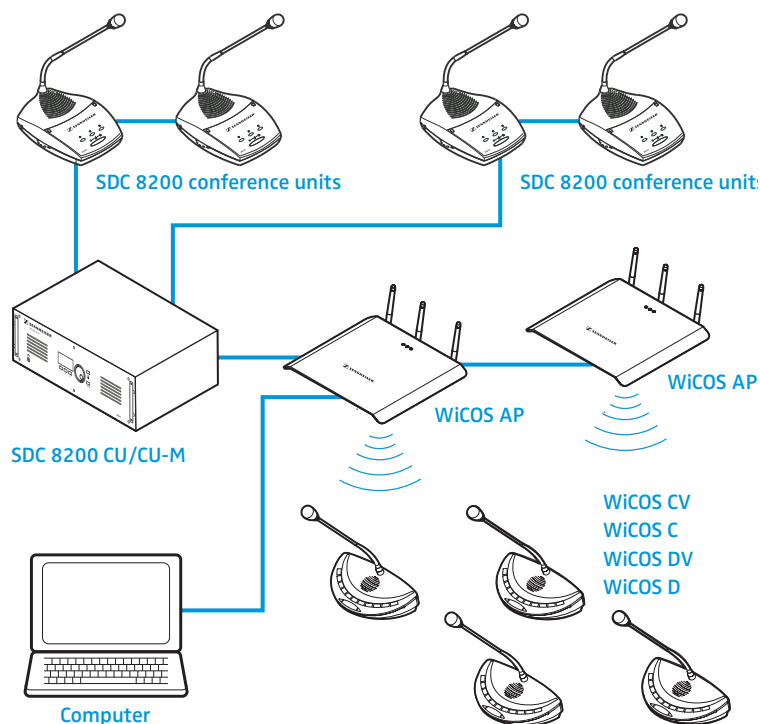

Connecting the access point to the SDC 8200 CU central unit

To integrate the WiCOS conference system into the wired SDC 8200 conference and interpretation system, proceed as you would to connect a conference unit to the SDC 8200 CU-M or SDC 8200 CU central unit. All wireless conference units are recognized by the SDC 8200 CU-M or SDC 8200 CU central unit, just like wired ones are.

For information on the configuration of your conference system, refer to the instruction manual of the SDC 8200 conference and interpretation system.

You require system cables for slave mode operation of the WiCOS system. The system cables are available in lengths of 2 m, 3 m, 5 m, 10 m, 20 m and 50 m (see "Accessories and spare parts" on page 83).

The system cables are used:

- to connect the access point to the SDC 8200 CU-M or SDC 8200 CU central unit or
- to interconnect several access points.

Several access points connected in series allow you to optimize the radio coverage, for example in order to hold a conference in several rooms at the same time.

The number of (wired and wireless) conference units is subject to the following restrictions in integrated operation (slave mode operation):

Number of conference units	SDC 8200 CU-M	SDC 8200 CU
< 50	yes	yes
> 50	–	yes

Connecting the access point to the central unit

i The length of the system cable between central unit and access point must not exceed 80 m.

- ▶ Connect the black RJ 45 plug of the system cable to one of the six RJ 45 sockets ("PORT 1- 6") of the SDC 8200 CU-M or SDC 8200 CU central unit.

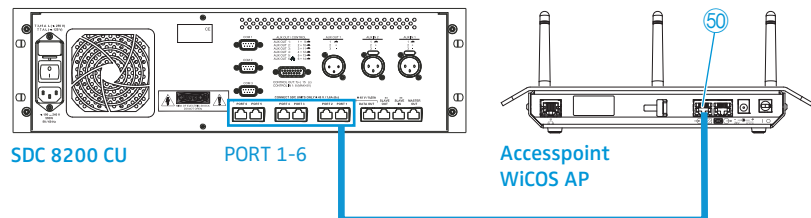

- ▶ Connect the grey RJ 45 plug of the system cable to the IN socket (RJ 45) ⑤ of the access point. The access point is connected to the central unit.

i In slave mode operation, the access point is powered via the central unit and the system cable. However, you can also connect the DC power supply. In this case, the power supply is automatically switched off via the system cable.

- ▶ Establish the network connection to your access point in order to be able to use the web server (see page 46).
- ▶ On the web server, set the operating mode of the access point to "Slave Mode" (see page 60). The conference system can now only be configured via the SDC 8200 CU-M or SDC 8200 CU central unit (see page 77).

Interconnecting several access points

Several interconnected access points are used:

- to operate small wireless conference systems in stand-alone operation in several rooms in parallel and to interconnect these systems for slave mode operation if required and
- to increase the radio coverage.



The length of the system cable between two access points must not exceed 80 m.

- ▶ Use a system cable to connect the OUT socket (RJ 45) ⑤1 of one access point to the IN socket (RJ 45) ⑤0 of the next access point.

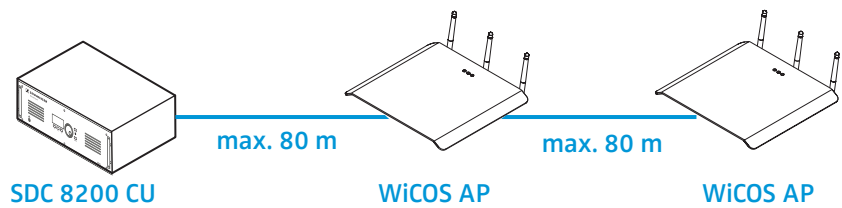

- ▶ To connect additional access points, proceed as described above.



You can connect a maximum of 15 interconnected access points to one of the six RJ 45 sockets ("PORT 1- 6") of the central unit.

Initializing the conference units with the SDC 8200 CU central unit

In slave mode operation, you initialize all conference units (wired and wireless) with the SDC 8200 CU-M or SDC 8200 CU central unit of the SDC 8200 conference and interpretation system.

Automatically initializing all conference units with the central unit

The automatic initialization allows you to initialize all conference units at once. In this case, the conference units are assigned microphone numbers automatically, in an arbitrary order.

- ▶ Switch on all wireless conference units that you want to use in your conference system (see page 31)
- ▶ Initialize the wireless conference units with the access point integrated into your SDC 8200 conference and interpretation system (see page 62).

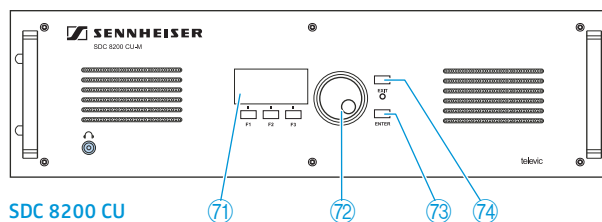

- ▶ Press the ENTER key ⑦3 on the SDC 8200 CU-M or SDC 8200 CU central unit to get into the central unit's operating menu. The first main menu "Conference" appears on the display ⑦1.

```
Initialise Units
2 Automatic Init
```

```
Automatic Init
Please wait
```

```
Automatic Init
Press ENTER to
Save Initialisation
```

- ▶ From the central unit's operating menu, choose with the jog wheel 72 "Conference", "Initialise Units" and "Automatic Init" one after the other. The text "Please wait" is shown on the display.

- ▶ When the text "Press ENTER to Save Initialisation" is shown on the display, press the ENTER key 73. The configuration is saved. All connected wired conference units and the switched-on wireless conference units that were initialized with the access point are initialized automatically. Any previous configuration is deleted.

Manually initializing all conference consoles with the central unit

If it is important that the conference units are assigned microphone numbers in a certain order or if you only want to use certain wireless conference units, we recommend choosing the manual initialization.

```
Initialise Units
1 Manual Init
```

- ▶ Switch on all wireless conference units that you want to use in your conference system (see page 31)
- ▶ Initialize the wireless conference units with the access point integrated into your SDC 8200 conference and interpretation system (see page 62).
- ▶ From the central unit's operating menu, choose with the jog wheel 71 "Conference", "Initialise Units" and "Manual Init" one after the other. The red signal light rings 78 and „Microphone active“ LED 77 on all wired conference consoles flash. With all wireless conference units, the microphone LED 10 flashes red and green and the signal light ring 2 flashes red.

SDC

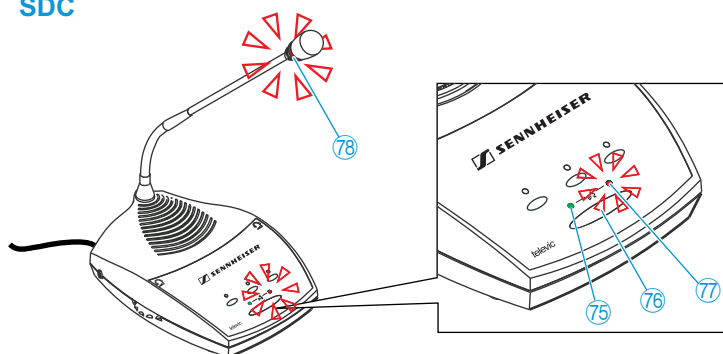

C CV D DV

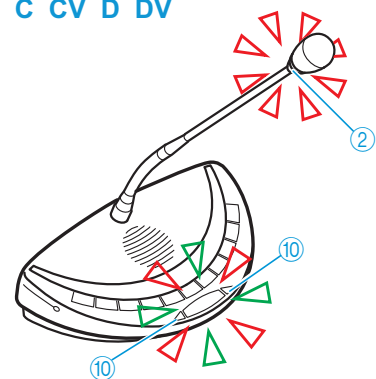

Only the signal light rings of the conference units are flashing while the signal light rings of the interpreter units remain dark. Initialization of the interpreter units is via the "Interpretation" menu (see the instruction manual of the SDC 8200 conference and interpretation system).

```
Full Init
Press ENTER to Save
```

- ▶ Choose with the jog wheel ⑦ "Full Init".
- ▶ One after the other, press the microphone key ⑪ or ⑦⑥ of all conference units in the order in which they are to be initialized.
As soon as the initialization of a wired conference unit is accepted by the central unit, the signal light ring ⑦⑧ and the „Microphone active“ LED ⑦ of this conference unit go off.
With the wireless conference units, the microphone LED ⑩ and the signal light ring ② go off.
- ▶ Press the ENTER key ⑦③ on the central unit to save this configuration.

Configuring the complete conference system - slave mode operation)

If the access point is in slave mode operation, you configure the conference system including the wireless conference units optionally via the :

- SDC 8200 CU-M central unit
- SDC 8200 CU central unit
- SDC 8200 SYS-M PC control software
- SDC 8200 SYS PC control software

(see the instruction manual of the SDC 8200 conference and interpretation system).

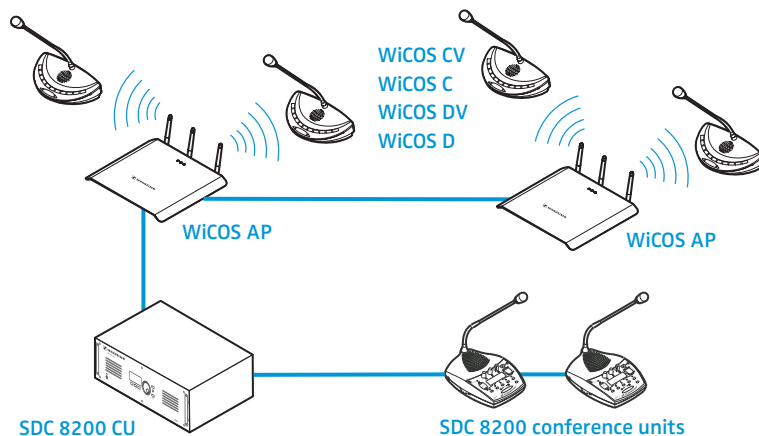

The web server of the access point offers you all setting and monitoring options as before. However, only the following settings have an effect on conference operation:

- In slave mode operation, you have to set the **“Maximum number of active microphones”** for the wired conference units via the SDC 8200 CU-M or SDC 8200 CU central unit and for the wireless conference units via the web server (see page 56).
- In slave mode operation, the **“Number of Interpretation channels”** also affects the maximum number of active microphones of the wireless conference units (see page 59).
- As a result of the different speaker limits of the central unit and the access point, it is not possible to use the **“FIFO”** conference mode in slave mode operation.

All other configurations can be changed, but in slave mode operation the changes do not affect conferencing.

Using stand-alone operation in parallel with slave mode operation

Once you have connected one or several access points to the SDC 8200 conference and interpretation system, you can continue to use an access point for stand-alone operation. For example, you can hold several conferences in parallel, in different rooms for instance. The SDC 8200 conference and interpretation system allows you to link all conferences to form one integrated conference.

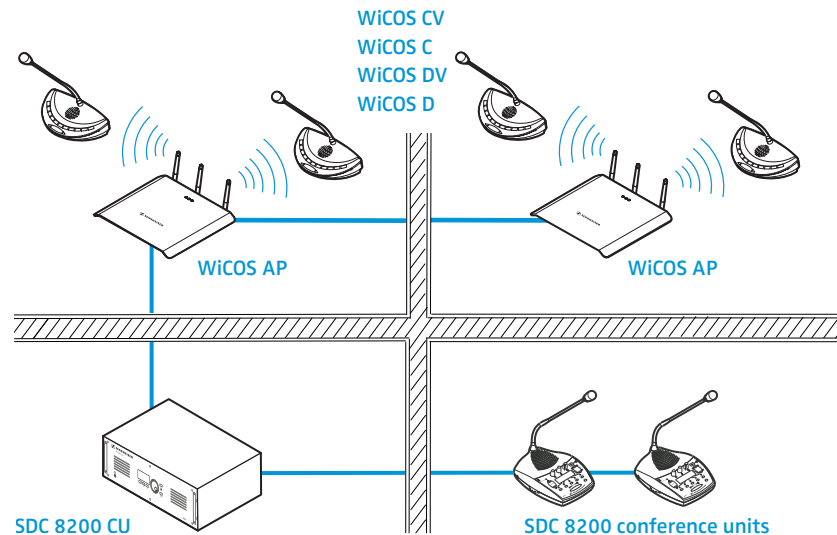

To use stand-alone operation in parallel to slave mode operation:

- ▶ Set the operating mode of the access point to **“Stand Alone”** (see page 60).
The WiCOS conference system functions completely independently of the SDC 8200 conference and interpretation system.

Holding a conference in slave mode operation

Discussion mode

The conference mode is set via the SDC 8200 CU-M or SDC 8200 CU central unit. (see the instruction manual of the SDC 8200 conference and interpretation system).

The conference units of the WiCOS conference system behave as they would in stand-alone operation. For detailed information on the use of the conference units, refer to page 33 and page 36.

Carrying out voting sessions

In order to start a voting session, you require the WiCOS CV or SDC 8200 CV chairman unit (see page 38 and the instruction manual of the SDC 8200 conference and interpretation system). You can also conveniently plan, manage and hold voting sessions via the SDC 8200 SYS-M or SDC 8200 SYS PC control software.

In order to be able to participate in voting sessions, you require a conference unit with voting function (see table below). For detailed information on how to participate in a voting session, refer to page 34 and

to the instruction manual of the SDC 8200 conference and interpretation system.

Only start voting sessions using the voting function with the parliamentary voting options (“yes”, “no”, “abstain”) as the WiCOS CV and WiCOS DV conference units support only this voting function. Otherwise, the result of the voting session could be falsified.

Conference unit	Voting function	Voting options	Voting administrator function
WiCOS CV	yes	3	yes
WiCOS DV	yes	3	no
WiCOS C	no	–	–
WiCOS D	no	–	–
SDC 8200 C	yes	3	no
SDC 8200 D	yes	3	no
SDC 8200 CC	yes	3	no
SDC 8200 DC	yes	3	no
SDC 8200 CV	yes	5	yes
SDC 8200 DV	yes	5	no
SDC 8200 ID	no	–	–

In slave mode operation, the SDC 8200 SYS-M or SDC 8200 SYS PC control software allows you to:

- conduct a secret ballot (all LEDs next to the voting keys ⑫, ⑬ and ⑭ will light up after you have pressed a key)
- log the voting result
- graphically display the voting result
- adjust additional voting options

For detailed information on the voting functions, refer to the instruction manual of the SDC 8200 SYS-M and SDC 8200 SYS PC control software.

Using the interpretation system

In order to be able to offer interpretations using the WiCOS system, you require the following components:

- SDC 8200 conference and interpretation system with SDC 8200 CU-M or SDC 8200 CU central unit
- up to 16 SDC 8200 ID interpreter units
- WiCOS CV chairman units
- WiCOS DV delegate units

In addition, you can also use the following wired SDC conference units: SDC 8200 DC, SDC 8200 CC, SDC 8200 DV and SDC 8200 CV.

Slave mode operation with an interpretation system

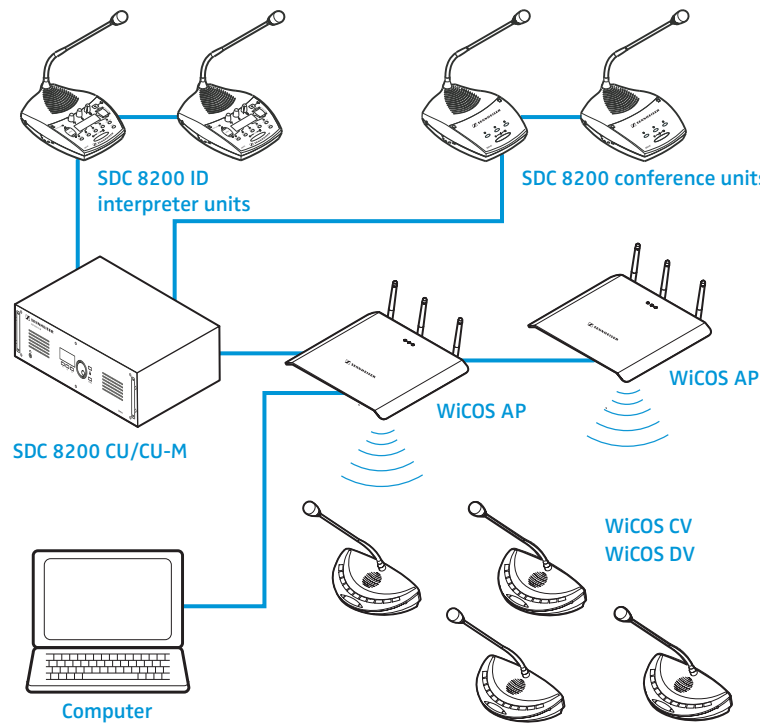

Configuring the interpretation system

For how to configure the interpretation system and how to use the SDC 8200 ID interpreter units, refer to the instruction manual of the SDC 8200 conference and interpretation system and to the instruction manual of the SDC 8200 SYS-M and SDC 8200 SYS PC control software.

Depending on the settings of the SDC 8200 conference and interpretation system, you have to adapt the following configuration of the access point to your interpretation system:

- ▶ Set the maximum number of interpretation channels “[Number of Interpretation channels](#)” (see page 59).
The WiCOS conference system can process up to 16 interpretation channels. In slave mode operation, the number of interpretation channels also affect the maximum number of simultaneously active microphones of the wireless conference units (see page 59).

Listening to the interpretation channels

For how to listen to interpretations using the WiCOS CV and WiCOS DV conference units, refer to page 35.

Cleaning the conference system

CAUTION! Liquids can damage the electronics of the devices!

Liquids entering the housing of the devices can cause a short-circuit and damage the electronics.

- ▶ Keep all liquids away from the devices.
 - ▶ Do not use any solvents or cleansing agents.
-

- ▶ Only use a slightly damp cloth to clean the devices from time to time.

If a problem occurs ...

Problem	Possible cause	Possible solution
Access point cannot be switched on even though it is connected to the DC power supply	The DC power supply is not suitable (e.g. you are using the WiCOS NT-BA charging power supply).	Use the WiCOS NT-AP DC power supply for powering the access point.
Web server cannot be called up	The network connection is not correctly established.	Make sure that the access point is correctly connected to the network/the computer (see page 22).
	The IP address of the access point has been changed.	Load the factory default settings and call up the web server using the address 192.168.0.10 (see page 43).
Conference unit does not establish a transmission link with the access point	The transmission range is exceeded.	Reduce the distance between conference units and access point. Place the access point as centrally and as high as possible (see page 23).
	The access point uses an encryption key that has not been assigned to the conference unit.	Set the encryption key of the access point to "default key" (automatic encryption) (see page 67). Assign the conference unit the same custom encryption key that is used by the access point (see page 67).
	The access point is just scanning the frequency bands.	Wait until the frequency bands have been scanned (this takes approx. 60 seconds).
Poor radio communication between access point and conference units	The transmission range is exceeded.	Reduce the distance between conference units and access point. Place the access point as centrally and as high as possible (see page 23). Increase the transmission power or set the transmission power to "Auto" (see page 52).
	The antennas are wrongly aligned or wrongly connected.	Only use the supplied antennas and make sure that they are correctly connected to the access point. Always align the antennas vertically and parallel to each other (see page 23).
Battery pack cannot be recharged	The charging power supply is not suitable (e.g. you are using the WiCOS NT-AP DC power supply).	Use the WiCOS NT-BA charging power supply for charging the battery pack.
	The battery pack is defective.	Check the status of the charging electronics (see page 26) and, if necessary, replace the defective battery pack by a new one.
Charge capacity drops rapidly	The battery pack is aged.	Replace the aged battery pack by a new one.
After switch-on, the delegate units only indicate requests to speak	You are using WiCOS D or WiCOS DV delegate units exclusively. The conference mode chosen requires a chairman unit for assigning the "speaking right" (e.g. "With request").	Use a chairman unit to assign the "speaking right" or set a conference mode which does not require the assignment of the "speaking right" (see page 56).
Conference unit is activated but the microphone does not work	The microphone is wrongly connected.	Make sure that the microphone is correctly connected to the conference unit (see page 25).

If a problem occurs that is not listed in the above table or if the problem cannot be solved with the proposed solutions, please contact your local Sennheiser partner for assistance.

To find a Sennheiser partner in your country, search at www.sennheiser.com under "Service & Support".

Accessories and spare parts

Cat. No. **Product name**

System components

502068	WiCOS AP	Access point
502062	WiCOS D	Delegate unit
502061	WiCOS C	Chairman unit
502066	WiCOS DV	Delegate unit with voting function and channel selection keys
502065	WiCOS CV	Chairman unit with voting function and channel selection keys

Battery pack

502882	WiCOS BA	Lithium-Ion battery pack for WiCOS conference units
--------	----------	---

Microphone

502883	WiCOS MIC	Gooseneck microphone
--------	-----------	----------------------

Power supplies

502897	WiCOS NT AP	DC power supply for access point
502885	WiCOS NT BA	Charging power supply for WiCOS BA battery pack

Transport case

502071	WiCOS CASE	Transport case (with wheels) for one conference system with up to 12 conference units and accessories
--------	------------	---

System cables

009842	SDC CBL RJ-45-2	System cable with two shielded RJ 45 plugs, 2 m
009853	SDC CBL RJ-45-3	System cable with two shielded RJ 45 plugs, 3 m
009844	SDC CBL RJ-45-5	System cable with two shielded RJ 45 plugs, 5 m
009845	SDC CBL RJ-45-10	System cable with two shielded RJ 45 plugs, 10 m
009846	SDC CBL RJ-45-20	System cable with two shielded RJ 45 plugs, 20 m
009847	SDC CBL RJ-45-50	System cable with two shielded RJ 45 plugs, 50 m

Accessory

043207	Thread insert (3/8" to 5/8")
--------	------------------------------

Specifications

WiCOS AP access point

Frequency response	150 - 15,000 Hz
Frequency ranges	2,4 GHz; 5,1 - 5,8 GHz
Signal-to-noise ratio	> 70 dB(A)
Supply voltage	24 V DC
Power consumption	6 W
Operating temperature	+5 °C to +45 °C
Dimensions	approx. 260 mm x 230 mm x 38 mm
Weight	approx. 1220 g
Color	RAL 7035

WiCOS D/WiCOS C/WiCOS DV/WiCOS CV conference units

Audio quality	16 bit / 32 kHz
Headphone socket	3.5 mm (> 32 Ω < 1 kΩ)
Output power at headphone output	16.5 mW / 32 Ω
Power consumption	approx. 3 W
Operating time	> 20 hrs (WiCOS BA battery pack)
Operating temperature	+5 °C to +45 °C
Dimensions	ca. 230 mm x 130 mm x 60 mm
Weight (incl. battery pack)	ca. 830 g
Color	RAL 9011

WiCOS BA Lithium-Ion battery pack

Nominal output voltage	7.2 V
Capacity	6600 mAh
Charging voltage	15 V ... 18 V
Charging current	2 A
Charging time	approx. 4 hrs
Operating temperature	0 °C to + 45 °C
Dimensions	approx. 170 mm x 75 mm x 25 mm
Weight	approx. 380 g
Color	RAL 9011

WiCOS MIC gooseneck microphone

Pick-up pattern	cardioid
Frequency response	50 - 20,000 Hz
Sensitivity (1 kHz)	8 mV / Pa +/- 2.5 dB
Max. SPL (1 kHz)	133 dB
Temperature range	0 °C to + 45 °C

Microphone gooseneck length	approx. 380 mm
Weight	approx. 70 g
Color	matt black

Certifications (WiCOS AP, WiCOS D, C, DV, CV, WiCOS BA)

In compliance with

Europe: CE	EMC	EN 301489-1/-17
	Radio	EN 300328 EN 301893 EN 300440-1/-2
	Safety	EN 60065 EN 62311 (SAR)

USA (WiCOS BA only): Meets the requirements of the UL 1642 safety standard.
The devices can be operated license-free in most countries of the European Union.

Approved by

Canada:	Industry Canada RSS 210 IC: 2099A-SDCW9000AP IC: 2099A-SDCW9000DU
USA:	FC 47 CFR Part 15 FCC ID: DMOSDCW9000AP FCC ID: DMOSDCW9000DU

Power supplies

	WiCOS NT-BA	WiCOS NT-AP
Input voltage	100 - 240 V / 50 - 60 Hz	100 - 240 V / 50 - 60 Hz
Input current (max.)	700 mA	400 mA
Output voltage	15 V ===	24 V ===
Output power	2 A	0.625 A
Operating temperature	0 °C to + 40 °C at maximum load	
Storage temperature	- 40 °C to + 70 °C	

Certifications (WiCOS NT-BA and WiCOS NT-AP)

In compliance with

Europe: CE	EMC	EN 55022, EN 55024
USA:	Safety	EN 60950
Canada:	47CFR Part 15 ICES 0003	

Certified by

Europe:	ENEC, VDE
USA/Canada:	cULus

Manufacturer Declarations

Warranty

Sennheiser electronic GmbH & Co. KG gives a warranty of 24 months on this product.

For the current warranty conditions, please visit our web site at www.sennheiser.com or contact your Sennheiser partner.

CE Declaration of Conformity

CE 0682

These devices are in compliance with the essential requirements and other relevant provisions of Directives 2004/108/EC, 2006/95/EC and 1999/05/EC.

The declaration is available at www.sennheiser.com.

Before putting the devices into operation, please observe the respective country-specific regulations.

Batteries or rechargeable batteries



The supplied batteries or rechargeable batteries can be recycled. Please dispose of them as special waste or return them to your specialist dealer. In order to protect the environment, only dispose of exhausted batteries.

Statements regarding FCC and Industry Canada

This device complies with Part 15 of the FCC Rules and with RSS-210 of Industry Canada. Operation is subject to the following two conditions: (1) this device may not cause harmful interference, and (2) this device must accept any interference received, including interference that may cause undesired operation.

This equipment has been tested and found to comply with the limits for a Class B digital device, pursuant to Part 15 of the FCC Rules. These limits are designed to provide reasonable protection against harmful interference in a residential installation. This equipment generates, uses and can radiate radio frequency energy and, if not installed and used in accordance with the instructions, may cause harmful interference to radio communications. However, there is no guarantee that interference will not occur in a particular installation. If this equipment does cause harmful interference to radio or television reception, which can be determined by turning the equipment off and on, the user is encouraged to try to correct the interference by one or more of the following measures:

- Reorient or relocate the receiving antenna.
- Increase the separation between the equipment and receiver.
- Connect the equipment into an outlet on a circuit different from that to which the receiver is connected.
- Consult the dealer or an experienced radio/TV technician for help.

This class B digital apparatus complies with the Canadian ICES-003

Changes or modifications made to this equipment not expressly approved by Sennheiser electronic Corp. may void the FCC authorization to operate this equipment.

Before putting the device into operation, please observe the respective country-specific regulations!

USA (WiCOS BA only): Meets the requirements of the UL 1642 safety standard. The devices can be operated license-free in most countries of the European Union. For more information, please contact your local regulatory authority for radio and telecommunications or your Sennheiser partner.

Index

A

Access point 9, 18, 21, 22, 23
 configuring the access point 46
 connecting to the SDC 8200 CU
 central unit 73
 initializing the conference units
 with the access point 62
 preparing the access point for
 transport 70
 setting the country-specific limit
 values 50
 setting the network address 48
 switching off 30
 switching on 29

Accessories 84

Address range 44

Admin 51

B

Battery pack
 charging 26
 checking the charge status 26
 inserting 27
 removing 27

C

Certifications 86

Chairman Config 65
 Function key 65
 Start/Stop Voting 65
 Volume Control 65

Channel selection display 13, 16

Cleaning 82

Conference Management 56

Conference mode 58
 setting the conference mode 57

Conference settings
 configuring the conference
 settings 56

Conference unit
 changing the volume of the con-
 ference units' loudspeakers 40
 initialization with the SDC 8200
 CU central unit 75
 monitoring initialized conference
 units 61
 muting the conference units
 temporarily 37
 preparing the conference unit for
 transport 71

setting the volume of the confe-
 rence units' loudspeakers 59
 setting up 28
 switching off all conference units
 automatically 32
 switching off manually 32
 switching on 31
 WiCOS C 9, 11
 WiCOS CV 9, 14
 WiCOS D 9, 10
 WiCOS DV 9, 12

Country selection 50

D

Direct access 58

Discussion
 ending a discussion 37

Dynamic frequency
 management 53

E

Encryption 67

Encryption keys 69

Extended operation 5

F

Factory default settings 43

FIFO 58

Firmware 67

Frequencies
 setting the frequencies 52

Frequency ranges
 monitoring the frequency
 ranges 54

G

General 52

Group 1 59

Group 2 59

Group 3 59

Group 4 59

H

Headphones
 adjusting the headphone
 volume 35
 connecting headphones 34

I

- Init Units 62
- Integrated operation 5, 7, 73
- Interpretation channels
 - setting the number of interpretation channels 59
- Interpretation system
 - using the interpretation system 80

M

- Maximum number of simultaneously active microphones 56
- Media control mode 15
 - activating the media control mode 41
- Microphone
 - activating the microphone 33
 - muting the microphone 37
 - switching off 34
- Multi-function display 15

N

- Network 22

O

- Operating modes of the selection keys
 - media control mode 65
 - setting 65
 - volume adjustment mode for loudspeakers 65
 - voting mode 65
- Override 58

P

- Password 51
- Password protection 51

Q

- Quality 54

R

- Request to speak
 - canceling a request to speak 34
 - making a request to speak 33
- Reset 43
- RF configuration 52
- RF signal strength
 - setting the RF signal strength 52

S

- Setup 47
- Slave mode operation 5, 7, 73
- Spare parts 84
- Speaking right
 - assigning the speaking right 36
- Specifications 85
- Stand-alone operation 6
- Standard operation 5
- Summary 47

T

- TCP/IP Settings 48
- Transport case 72
- Troubleshooting 83

U

- Unit monitoring 61
- Update 67

V

- Volume adjustment mode for loudspeakers 15
- Voting mode 15
- Voting session
 - canceling a voting session 39
 - clearing the voting result 39
 - ending a voting session 39
 - participating in a voting session 34
 - starting a voting session 38

W

- Web server 19, 44
- WiCOS BA 17
- WiCOS CASE 20
- Wired conference system 73
- With request 58
- With request no clear 58





Sennheiser electronic GmbH & Co. KG
Am Labor 1, 30900 Wedemark, Germany
www.sennheiser.com

Printed in Germany
Publ. 02/09
532842/A01