

TEST REPORT

Test report no.: 1-3400-01-03/11-A



Testing laboratory

CETECOM ICT Services GmbH
Untertuerkheimer Strasse 6 – 10
66117 Saarbruecken / Germany
Phone: + 49 681 5 98 - 0
Fax: + 49 681 5 98 - 9075
Internet: <http://www.cetecom.com>
e-mail: ict@cetecom.com

Accredited test laboratory:
The test laboratory (area of testing) is accredited according to DIN EN ISO/IEC 17025
DAkkS registration number: D-PL-12076-01-01
Area of Testing: Radio/Satellite Communications

Applicant

Sennheiser electronic GmbH & Co. KG
Am Labor 1
30900 Wedemark / GERMANY
Phone: +49 5130 600 -0
Fax: +49 5130 600-574
Contact: Volker Bartsch
e-mail: volker.bartsch@sennheiser.com
Phone: +49 5130 600-465

Manufacturer

Sennheiser electronic GmbH & Co. KG
Am Labor 1
30900 Wedemark / GERMANY

Test standard/s

47 CFR Part 15	Title 47 of the Code of Federal Regulations; Chapter I Part 15 - Radio frequency devices
RSS - 210 Issue 8	Spectrum Management and Telecommunications - Radio Standards Specification Low-power Licence-exempt Radiocommunication Devices (All Frequency Bands): Category I Equipment

For further applied test standards please refer to section 3 of this test report.

Test item

Kind of test item:	Headset with Bluetooth Interface
Model name:	S1 DIGITAL
FCC ID:	DMOS1CW3011
IC:	2099A-S1CW3011
Frequency:	2400.00 – 2483.50 MHz
Power supply:	3.0 V DC by Battery and Power Supply
Temperature range:	20°C



This test report is electronically signed and valid without handwriting signature. For verification of the electronic signatures, the public keys can be requested at the testing laboratory.

Test performed:

Jakob Reschke

Test report authorised:

Joerg Warken

1 Table of contents	
1	Table of contents2
2	General information3
2.1	Notes.....3
2.2	Application details.....3
3	Test standard/s3
4	Test environment.....3
5	Test item4
6	Test laboratories sub-contracted4
7	Summary of measurement results5
8	RF measurement testing.....6
8.1	Description of test setup6
8.1.1	Radiated measurements.....6
8.1.2	Conducted measurements.....7
8.2	Additional comments7
8.3	RSP100 test report cover sheet / performance test data8
9	Measurement results.....9
9.1	Antenna gain9
9.2	Power spectral density10
9.3	Carrier frequency separation11
9.4	Number of hopping channels.....13
9.5	Time of occupancy (dwell time)15
9.6	Spectrum bandwidth of a FHSS system – 20 dB bandwidth16
9.7	Maximum output power22
9.8	Band edge compliance conducted29
9.9	Band edge compliance radiated37
9.10	TX spurious emissions conducted42
9.11	TX spurious emissions radiated.....50
9.12	RX spurious emissions radiated58
9.13	TX spurious emissions radiated < 30 MHz62
9.14	TX spurious emissions conducted < 30 MHz.....64
10	Test equipment and ancillaries used for tests67
Annex A	Photographs of the test setup.....70
Annex B	External photographs of the EUT.....71
Annex C	Internal photographs of the EUT74
Annex D	Document history83
Annex E	Further information.....83

2 General information

2.1 Notes

The test results of this test report relate exclusively to the test item specified in this test report. CETECOM ICT Services GmbH does not assume responsibility for any conclusions and generalisations drawn from the test results with regard to other specimens or samples of the type of the equipment represented by the test item. The test report may only be reproduced or published in full. Reproduction or publication of extracts from the report requires the prior written approval of CETECOM ICT Services GmbH.

This test report is electronically signed and valid without handwriting signature. For verification of the electronic signatures, the public keys can be requested at the testing laboratory.

2.2 Application details

Date of receipt of order:	2011-05-04
Date of receipt of test item:	2011-05-05
Start of test:	2011-05-05
End of test:	2011-05-30
Person(s) present during the test:	Mr. Oliver Gelhard

3 Test standard/s

Test standard	Version	Test standard description
47 CFR Part 15	2009-10	Title 47 of the Code of Federal Regulations; Chapter I Part 15 - Radio frequency devices
RSS - 210 Issue 8	2010-12	Spectrum Management and Telecommunications - Radio Standards Specification Low-power Licence-exempt Radiocommunication Devices (All Frequency Bands): Category I Equipment

4 Test environment

Temperature:	T_{nom}	20	°C during room temperature tests
	T_{max}	-/-	°C during high temperature test
	T_{min}	-/-	°C during low temperature test
Relative humidity content:		33	%
Air pressure:			not relevant for this kind of testing
Power supply:	V_{nom}	3.0	V DC by Battery and Power Supply
	V_{max}	-/-	V
	V_{min}	-/-	V

5 Test item

Kind of test item	:	Headset with Bluetooth Interface
Type identification	:	S1 DIGITAL
S/N serial number	:	Not defined
HW hardware status	:	See pictures
SW software status	:	Bluetooth: 2901 Headset: 1001
Frequency band [MHz]	:	2400.00 – 2483.50 MHz
Type of modulation	:	GFSK, Pi/4 DQPSK, 8DPSK
Number of channels	:	79
Antenna	:	Integrated antenna
Power supply	:	3.0 V DC by Battery and Power Supply
Temperature range	:	20°C

6 Test laboratories sub-contracted

None

7 Summary of measurement results

- No deviations from the technical specifications were ascertained
- There were deviations from the technical specifications ascertained

TC Identifier	Description	Verdict	Date	Remark
RF-Testing	CFR Part 15 RSS 210, Issue 7, Annex 8	Passed	2011-06-30	-/-

Test specification clause	Test case	Temperature conditions	Power source voltages	Mode	Pass	Fail	NA	NP	Results (max.)
§15.247(b)(4) RSS 210 / A8.4(2)	Antenna gain	Nominal	Nominal	GFSK	<input checked="" type="checkbox"/>	<input type="checkbox"/>	<input type="checkbox"/>	<input type="checkbox"/>	complies
§15.247(e) RSS 210 / A8.2(b)	Power spectral density	Nominal	Nominal	GFSK Pi/4 DQPSK 8 DPSK	<input type="checkbox"/>	<input type="checkbox"/>	<input checked="" type="checkbox"/>	<input type="checkbox"/>	
§15.247(a)(1) RSS 210 / A8.1(b)	Carrier frequency separation	Nominal	Nominal	GFSK	<input checked="" type="checkbox"/>	<input type="checkbox"/>	<input type="checkbox"/>	<input type="checkbox"/>	complies
§15.247(a)(1) RSS 210 / A8.1(d)	Number of hopping channels	Nominal	Nominal	GFSK	<input checked="" type="checkbox"/>	<input type="checkbox"/>	<input type="checkbox"/>	<input type="checkbox"/>	complies
§15.247(a)(1) (iii) RSS 210 / A8.3(1)	Time of occupancy (dwell time)	Nominal	Nominal	GFSK Pi/4 DQPSK 8 DPSK	<input checked="" type="checkbox"/>	<input type="checkbox"/>	<input type="checkbox"/>	<input type="checkbox"/>	complies
§15.247(a)(1) RSS 210 / A8.2(a)	Spectrum bandwidth of a FHSS system 20dB bandwidth	Nominal	Nominal	GFSK Pi/4 DQPSK 8 DPSK	<input checked="" type="checkbox"/> <input checked="" type="checkbox"/> <input checked="" type="checkbox"/>	<input type="checkbox"/> <input type="checkbox"/> <input type="checkbox"/>	<input type="checkbox"/> <input type="checkbox"/> <input type="checkbox"/>	<input type="checkbox"/> <input type="checkbox"/> <input type="checkbox"/>	
§15.247(b)(1) RSS-210 / A8.4(2)	Maximum output power	Nominal	Nominal	GFSK Pi/4 DQPSK 8 DPSK	<input checked="" type="checkbox"/> <input checked="" type="checkbox"/> <input checked="" type="checkbox"/>	<input type="checkbox"/> <input type="checkbox"/> <input type="checkbox"/>	<input type="checkbox"/> <input type="checkbox"/> <input type="checkbox"/>	<input type="checkbox"/> <input type="checkbox"/> <input type="checkbox"/>	
§15.247(d) RSS-210 / A8.5	Band edge compliance conducted	Nominal	Nominal	GFSK Pi/4 DQPSK 8 DPSK	<input checked="" type="checkbox"/> <input checked="" type="checkbox"/> <input checked="" type="checkbox"/>	<input type="checkbox"/> <input type="checkbox"/> <input type="checkbox"/>	<input type="checkbox"/> <input type="checkbox"/> <input type="checkbox"/>	<input type="checkbox"/> <input type="checkbox"/> <input type="checkbox"/>	complies
§15.205 RSS-210 / A8.5	Band edge compliance radiated	Nominal	Nominal	GFSK Pi/4 DQPSK 8 DPSK	<input checked="" type="checkbox"/> <input checked="" type="checkbox"/> <input checked="" type="checkbox"/>	<input type="checkbox"/> <input type="checkbox"/> <input type="checkbox"/>	<input type="checkbox"/> <input type="checkbox"/> <input type="checkbox"/>	<input type="checkbox"/> <input type="checkbox"/> <input type="checkbox"/>	complies
§15.247(d) RSS-210 / A8.5	TX spurious emissions conducted	Nominal	Nominal	GFSK Pi/4 DQPSK 8 DPSK	<input checked="" type="checkbox"/> <input checked="" type="checkbox"/> <input checked="" type="checkbox"/>	<input type="checkbox"/> <input type="checkbox"/> <input type="checkbox"/>	<input type="checkbox"/> <input type="checkbox"/> <input type="checkbox"/>	<input type="checkbox"/> <input type="checkbox"/> <input type="checkbox"/>	complies
§15.247(d) RSS-210 / A8.5	TX spurious emissions radiated	Nominal	Nominal	GFSK	<input checked="" type="checkbox"/>	<input type="checkbox"/>	<input type="checkbox"/>	<input type="checkbox"/>	complies
§15.109 RSS-Gen.	RX spurious emissions radiated	Nominal	Nominal	-/-	<input checked="" type="checkbox"/>	<input type="checkbox"/>	<input type="checkbox"/>	<input type="checkbox"/>	complies
§15.209(a) RSS-Gen	TX spurious emissions radiated < 30 MHz	Nominal	Nominal	GFSK	<input checked="" type="checkbox"/>	<input type="checkbox"/>	<input type="checkbox"/>	<input type="checkbox"/>	complies
§15.107(a)	Conducted emissions < 30 MHz	Nominal	Nominal	GFSK	<input checked="" type="checkbox"/>	<input type="checkbox"/>	<input type="checkbox"/>	<input type="checkbox"/>	complies

Note: NA = Not Applicable; NP = Not Performed

8 RF measurement testing

8.1 Description of test setup

8.1.1 Radiated measurements

The radiated measurements are performed in vertical and horizontal plane in the frequency range from 9 kHz to 25 GHz in semi-anechoic chambers. The EUT is positioned on a non-conductive support with a height of 0.80 m above a conductive ground plane that covers the whole chamber. The receiving antennas are confirmed with specifications ANSI C63.2-1996 clause 15 and ANSI C63.4-2003 clause 4.1.5. These antennas can be moved over the height range between 1.0 m and 4.0 m in order to search for maximum field strength emitted from EUT. The measurement distances between EUT and receiving antennas are indicated in the test setups for the various frequency ranges. For each measurement, the EUT is rotated in all three axes until the maximum field strength is received. The wanted and unwanted emissions are received by spectrum analysers where the detector modes and resolution bandwidths over various frequency ranges are set according to requirement ANSI C63-4-2003 clause 4.2.

Antennas are confirmed with ANSI C63.2-1996 item 15.

Semi anechoic chamber

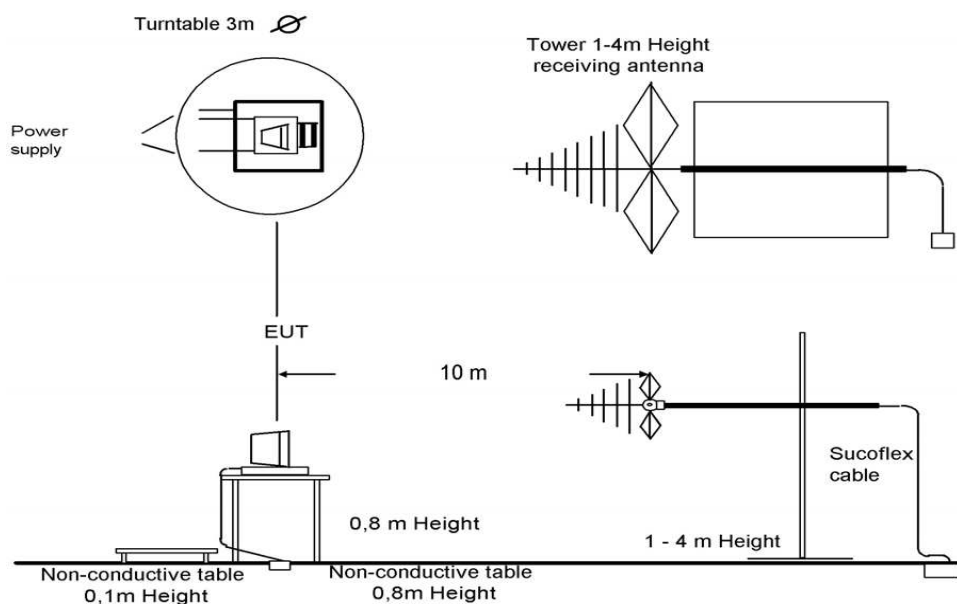

Picture 1: Diagram radiated measurements

9 kHz - 30 MHz:	active loop antenna
30 MHz – 1 GHz:	tri-log antenna
> 1 GHz:	horn antenna

All measurements are done in accordance with the Filing and Measurement Guidelines for Frequency Hopping Spread Spectrum Systems DA 00-705 and Appendix A "BLUETOOTH® APPROVALS"

The EUT is powered by an external power supply with nominal voltage. The signalling is performed from outside the chamber with a signalling unit (CMU200 or other) by air link using signalling antenna.

8.1.2 Conducted measurements

The EUT's RF signal is coupled out by the antenna connector which is supplied by the manufacturer. The signal is first 10dB attenuated before it is power divided (~6dB loss per branch). One of the signal paths is connected to the communication base Station (CMU200 or other), the other one is connected to the spectrum analyzer. The specific losses for both signal paths are first checked within a calibration. The measurement readings on the signalling unit/spectrum analyzer are corrected by the specific test set-up loss. The attenuator, power divider, signalling unit and the spectrum analyzer are impedance matched on 50 Ohm.

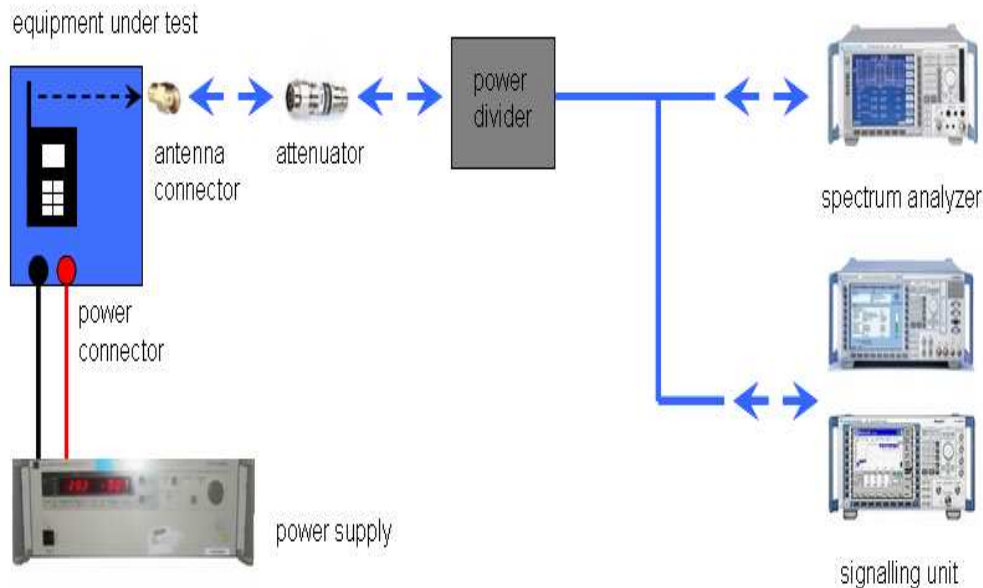

Picture 2: Diagram conducted measurements

8.2 Additional comments

The Bluetooth® word mark and logos are owned by the Bluetooth SIG Inc. and any use of such marks by Cetecom ICT Services GmbH is under license.

Reference documents: None

Special test descriptions: None

Configuration descriptions: TX tests: were performed with x-DH5 packets and static PRBS pattern payload.
RX/Standby tests: BT test mode enabled, scan enabled, TX Idle

- Test mode:
- Bluetooth Test mode loop back enabled (EUT is controlled over CBT/CMU)
 - Special software is used. EUT is transmitting pseudo random data by itself

8.3 RSP100 test report cover sheet / performance test data

Test report number	:	1-3400-01-03/11
Equipment model number	:	S1 DIGITAL
Certification number	:	2099A-S1CW3011
Manufacturer (complete address)	:	Sennheiser electronic GmbH & Co. KG Am Labor 1 30900 Wedemark / GERMANY
Tested to radio standards specification no.	:	RSS 210, Issue 8, Annex 8
Open area test site IC No.	:	IC 3462C-1
Frequency range	:	2400 – 2483.5 MHz-band (2402 – 2480 MHz)
RF-power [W] (max.)	:	Cond.: 4.44 mW (GFSK) EIRP: 1.36 mW (GFSK) Cond.: 2.48 mW (Pi/4-DQPSK) EIRP: 0.80 mW (Pi/4-DQPSK) Cond.: 2.55 mW (8DPSK) EIRP: 0.82 mW (8DPSK)
Occupied bandwidth (99%-BW) [kHz]	:	920 (GFSK) 1263 (Pi/4-DQPSK) 1299 (8DPSK)
Type of modulation	:	GFSK; Pi/4-DQPSK; 8DPSK
Emission designator (TRC-43)	:	920KFXD (GFSK) 1M26GXD (Pi/4-DQPSK) 1M30GXD (8DPSK)
Antenna information	:	Integrated antenna
Transmitter spurious (worst case) [μV/m @ 3m]	:	124 μV/m @ 4804 MHz
Receiver spurious (worst case) [μV/m @ 3m]	:	24 μV/m @ 400 MHz

ATTESTATION:

DECLARATION OF COMPLIANCE:

I attest that the testing was performed or supervised by me; that the test measurements were made in accordance with the above-mentioned Industry Canada standard(s); and that the equipment identified in this application has been subjected to all the applicable test conditions specified in the Industry Canada standards and all of the requirements of the standard have been met.

Laboratory manager:

2011-06-30

Jakob Reschke

Date

Name

Signature

9 Measurement results

9.1 Antenna gain

Measurement:

The antenna gain of the complete system is calculated by the difference of radiated power in EIRP and the conducted power of the module. For normal Bluetooth® devices, the GFSK modulation is used.

Measurement parameters:

Measurement parameter	
Detector:	Peak
Sweep time:	Auto
Video bandwidth:	3 MHz
Resolution bandwidth:	3 MHz
Span:	5 MHz
Trace-Mode:	Max hold

Limits:

FCC	IC
CFR Part 15.247 (b)(4)	RSS 210, Issue 7, A 8.4(2)
Antenna Gain	
6 dBi	

Results:

T_{nom}	V_{nom}	lowest channel 2402 MHz	middle channel 2441 MHz	highest channel 2480 MHz
Conducted power [dBm] Measured with GFSK modulation		6.23	6.47	6.13
Radiated power [dBm] Measured with GFSK modulation		1.33	0.57	0.36
Gain [dBi] Calculated		-4.90	-5.90	-5.77

Result: The result of the measurement is passed.

9.2 Power spectral density

Description:

Measurement of the power spectral density of a digital modulated system. This requirement is only valid for digitally modulated systems without hopping functionality.

Measurement:

Measurement parameter	
Detector:	Peak
Sweep time:	500 s
Video bandwidth:	3 kHz
Resolution bandwidth:	3 kHz
Span:	150 kHz
Trace-Mode:	Max Hold

Limits:

FCC	IC
CFR Part 15.247 (e)	RSS 210, Issue 7, A 8.2(b)
Power Spectral Density	
For digitally modulated systems the transmitter power spectral density conducted from the transmitter to the antenna shall not be greater than 8 dBm in any 3 kHz band during any time interval of continuous transmission or over 1.0 second if the transmission exceeds 1.0-second duration.	

Result:

Modulation	Power spectral density [dBm/3kHz]		
	2412 MHz	2437 MHz	2462 MHz
Frequency			
GFSK	Not required for hopping systems !		
Pi/4 DQPSK			
8DPSK			
Measurement uncertainty	± 1.5 dB		

9.3 Carrier frequency separation

Description:

Measurement of the carrier frequency separation of a hopping system. The carrier frequency separation is constant for all modulation-modes. We use GFSK-modulation to show compliance. EUT in hopping mode.

Measurement:

Measurement parameter	
Detector:	Peak
Sweep time:	Auto
Video bandwidth:	100 kHz
Resolution bandwidth:	100 kHz
Span:	4 MHz
Trace-Mode:	Max Hold

Limits:

FCC	IC
CFR Part 15.247 (a)(1)	RSS 210, Issue 7, A 8.1(b)
Carrier Frequency Separation	
Minimum 25 kHz or two-thirds of the 20 dB bandwidth of the hopping system whichever is greater.	

Result:

Carrier frequency separation	~ 1 MHz
------------------------------	---------

Result: The result of the measurement is passed.

Plot 1: Carrier Frequency Separation (GFSK)

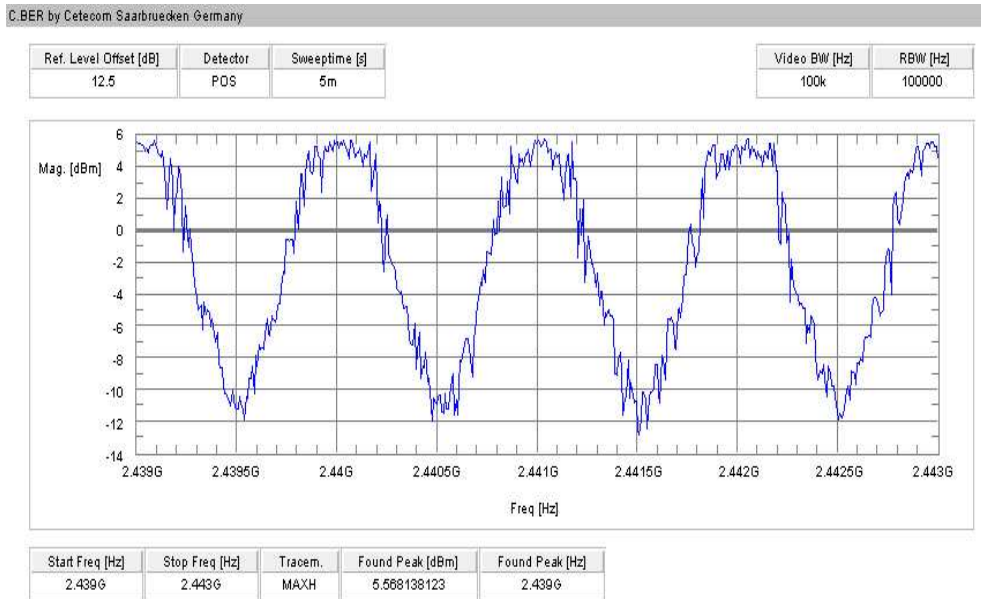

9.4 Number of hopping channels

Description:

Measurement of the total number of used hopping channels. The number of hopping channels is constant for all modulation-modes. We use GFSK-modulation to show compliance. EUT in hopping mode.

Measurement:

Measurement parameter	
Detector:	Peak
Sweep time:	Auto
Video bandwidth:	500 kHz
Resolution bandwidth:	500 kHz
Span:	Plot 1: 2400 – 2445 MHz Plot 2: 2445 – 2485 MHz
Trace-Mode:	Max Hold

Limits:

FCC	IC
CFR Part 15.247 (a)(1)	RSS 210, Issue 7, A 8.1(d)
Number of hopping channels	
At least 15 non overlapping hopping channels	

Result:

Number of hopping channels	79
----------------------------	----

Result: The result of the measurement is passed.

Plot 1: Number of hopping channels (GFSK)

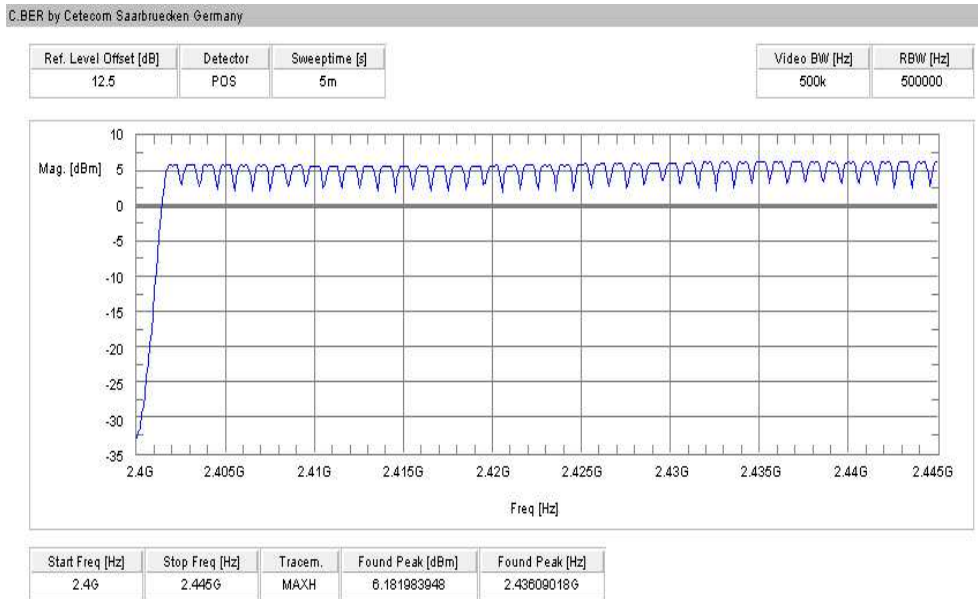

Plot 2: Number of hopping channels (GFSK)

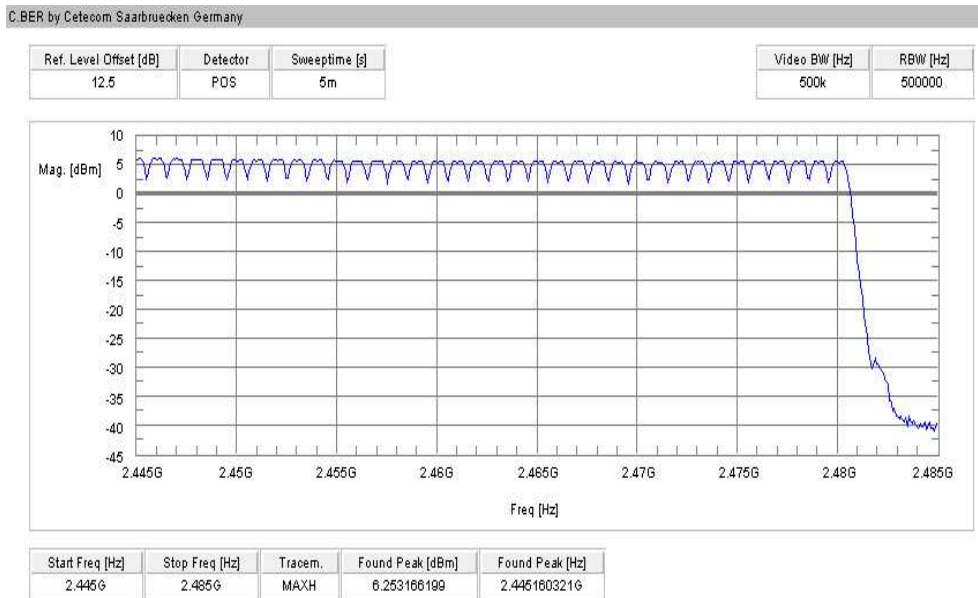

9.5 Time of occupancy (dwell time)

Measurement:

For Bluetooth® devices no measurements mandatory depending on the fixed requirements according to the Bluetooth® Core Specifications!

For Bluetooth® devices:

The channel staying time of 0.4 s within a 31.6 second period in data mode is constant for Bluetooth® devices and independent from the packet type (packet length). The calculation for a 31.6 second period is as follows:

Channel staying time = time slot length * hop rate / number of hopping channels * 31.6 s

Example for a DH1 packet (with a maximum length of one time slot)
 Channel staying time = $625 \mu\text{s} * 1600 * 1/\text{s} / 79 * 31.6 \text{ s} = 0.4 \text{ s}$ (in a 31.6 s period)

For multi-slot packets the hopping is reduced according to the length of the packet.

Example for a DH3 packet (with a maximum length of three time slots)
 Channel staying time = $3 * 625 \mu\text{s} * 1600/3 * 1/\text{s} / 79 * 31.6 \text{ s} = 0.4 \text{ s}$ (in a 31.6 s period)

Example for a DH5 packet (with a maximum length of five time slots)
 Channel staying time = $5 * 625 \mu\text{s} * 1600/5 * 1/\text{s} / 79 * 31.6 \text{ s} = 0.4 \text{ s}$ (in a 31.6 s period)

This is according to the Bluetooth® Core Specification V2.0 & V2.1 & V3.0 & V4.0 (+ critical errata) for all Bluetooth® devices.

The following table shows the relations:

Packet Size	Pulse Width [ms] *	Max. number of transmissions per channel in 31.6 sec
DH1	0.366	640
DH3	1.622	214
DH5	2.870	128

* according to Bluetooth® specification

Result:

Packet Size	Pulse Width [ms]*	Max. number of transmissions in 31.6 sec	Dwell time [Pulse width * Number of transmissions]
DH1	0.366	640	234.2 ms
DH3	1.622	214	347.1 ms
DH5	2.870	128	367.4 ms

Limits:

FCC	IC
CFR Part 15.247 (a)(1)(iii)	RSS 210, Issue 7, A 8.3(1)
Time of occupancy (dwell time)	
The frequency hopping operation shall have an average time of occupancy on any frequency not exceeding 0.4 seconds within a duration in seconds equal to the number of hopping frequencies multiplied by 0.4.	

Result: The result of the measurement is passed.

9.6 Spectrum bandwidth of a FHSS system – 20 dB bandwidth

Description:

Measurement of the 20dB bandwidth of the modulated signal. The measurement is performed according to the "Measurement Guidelines" (DA 00-705, March 30, 2000). EUT in single channel mode.

Measurement:

Measurement parameter	
Detector:	Peak
Sweep time:	2 s
Video bandwidth:	30 kHz
Resolution bandwidth:	10 kHz
Span:	3 MHz
Trace-Mode:	Max Hold

Limits:

FCC	IC
CFR Part 15.247 (a)(1)	RSS 210, Issue 7, A 8.2(a)
Spectrum bandwidth of a FHSS system – 20 dB bandwidth	
GFSK < 1000 kHz Pi/4 DQPSK < 1500 kHz 8DPSK < 1500 kHz	

Result:

Modulation	20 dB BANDWIDTH [kHz]		
	2402 MHz	2441 MHz	2480 MHz
Frequency			
GFSK	920	920	920
Pi/4 DQPSK	1263	1244	1244
8DPSK	1299	1263	1263
Measurement uncertainty	± 10 kHz		

Result: The result of the measurement is passed.

Plot 1: Channel 00 / GFSK

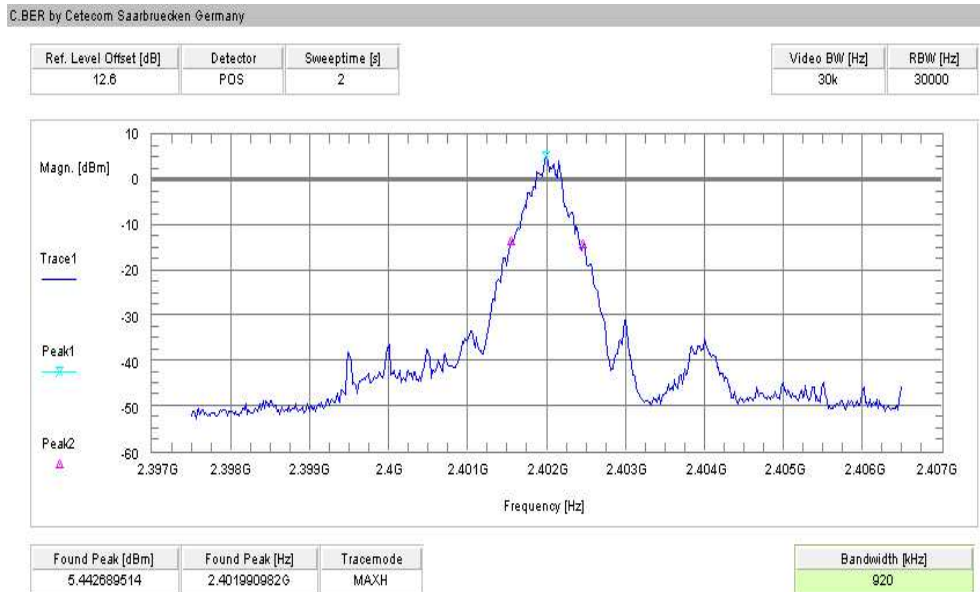

Plot 2: Channel 39 / GFSK

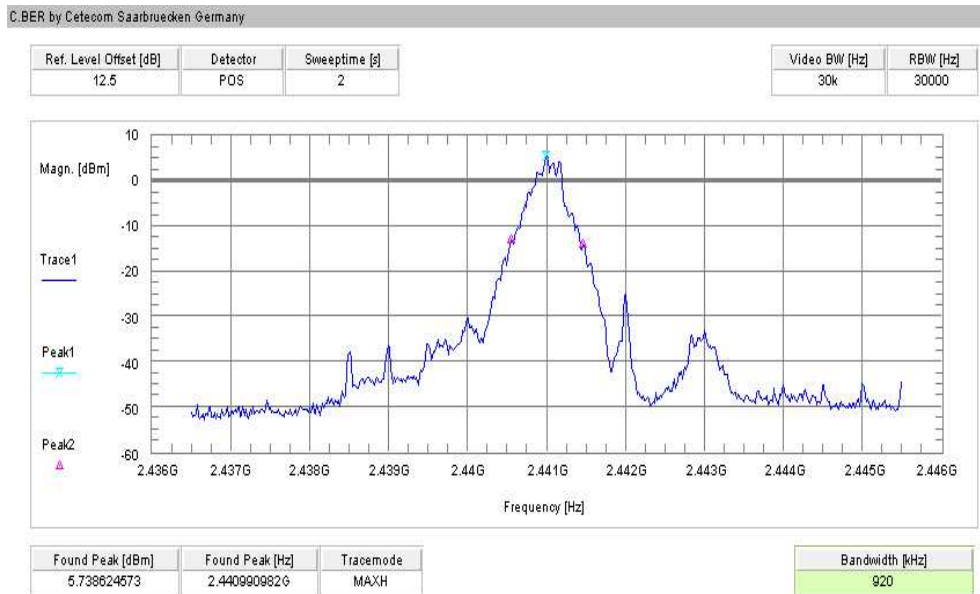

Plot 3: Channel 78 / GFSK

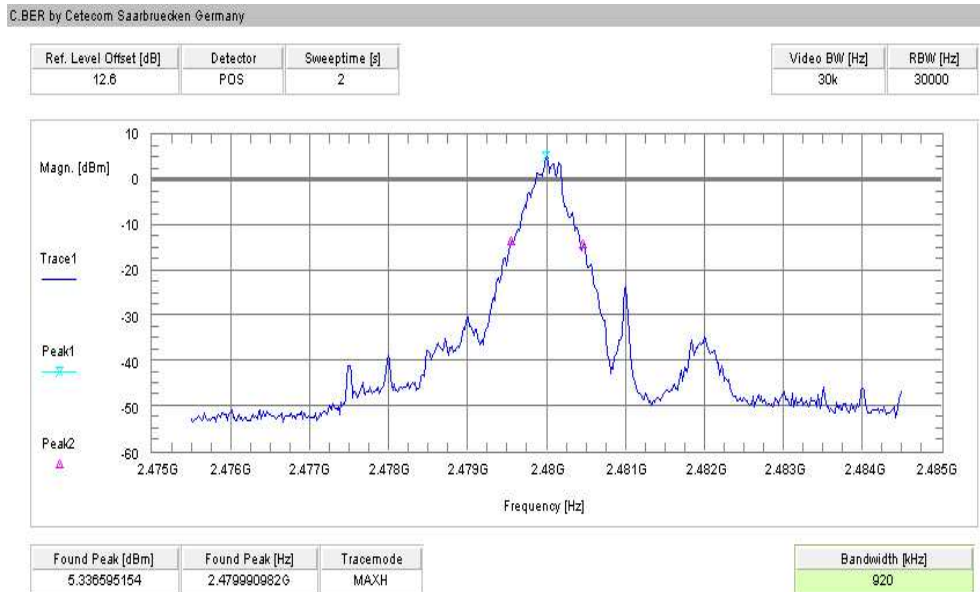

Plot 4: Channel 00 / Pi/4 DQPSK



Plot 5: Channel 39 / Pi/4 DQPSK



Plot 6: Channel 78 / Pi/4 DQPSK



Plot 7: Channel 00 / 8DPSK

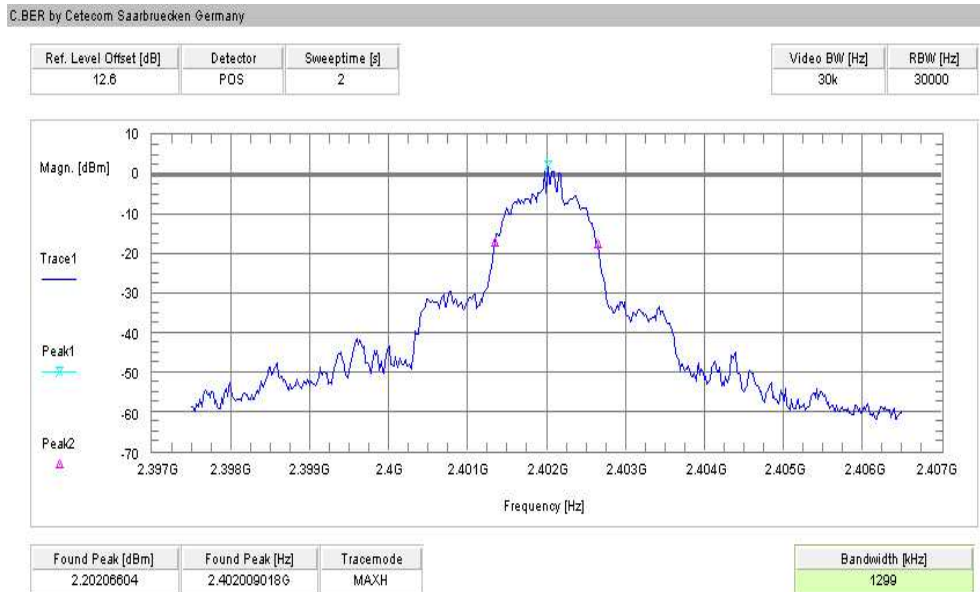

Plot 8: Channel 39 / 8DPSK



Plot 9: Channel 78 / 8DPSK

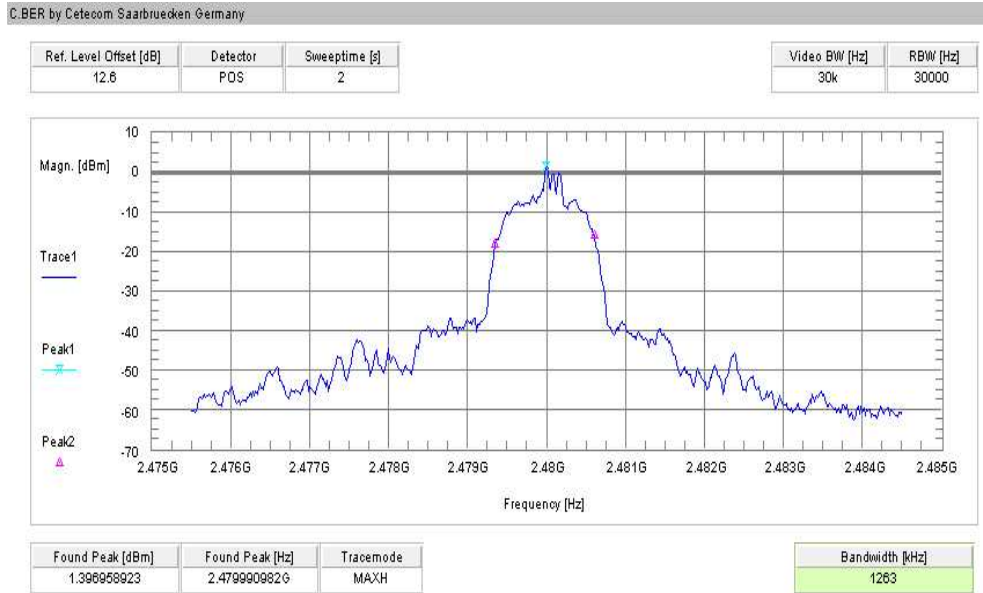

9.7 Maximum output power

Description:

Measurement of the maximum output power conducted and radiated. EUT in single channel mode.

Measurement:

Measurement parameter	
Detector:	Peak
Sweep time:	Auto
Video bandwidth:	3 MHz
Resolution bandwidth:	3 MHz
Span:	3 MHz
Trace-Mode:	Max Hold

Limits:

FCC	IC
CFR Part 15.247 (b)(1)	RSS 210, Issue 7, A 8.4(2)
Maximum output power	
[Conducted: 0.125 W – antenna gain max. 6 dBi] Systems using more than 75 hopping channels: Conducted: 1.0 W – antenna gain max. 6 dBi	

Result:

Modulation Frequency	Maximum output power conducted [dBm]		
	2402 MHz	2441 MHz	2480 MHz
GFSK	6.23	6.47	6.13
Pi/4 DQPSK	3.94	3.90	2.93
8DPSK	4.04	4.07	3.16
Measurement uncertainty	± 1 dB		

Modulation Frequency	Maximum output power radiated - EIRP [dBm]		
	2402 MHz	2441 MHz	2480 MHz
GFSK	1.33	0.57	0.36
Pi/4 DQPSK *)	-0.96	-2.00	-2.84
8DPSK *)	-0.86	-1.83	-2.61
Measurement uncertainty	± 3 dB		

*) - Values calculated with antenna gain

Result: The result of the measurement is passed.

Plot 1: Channel 00 / GFSK (conducted)

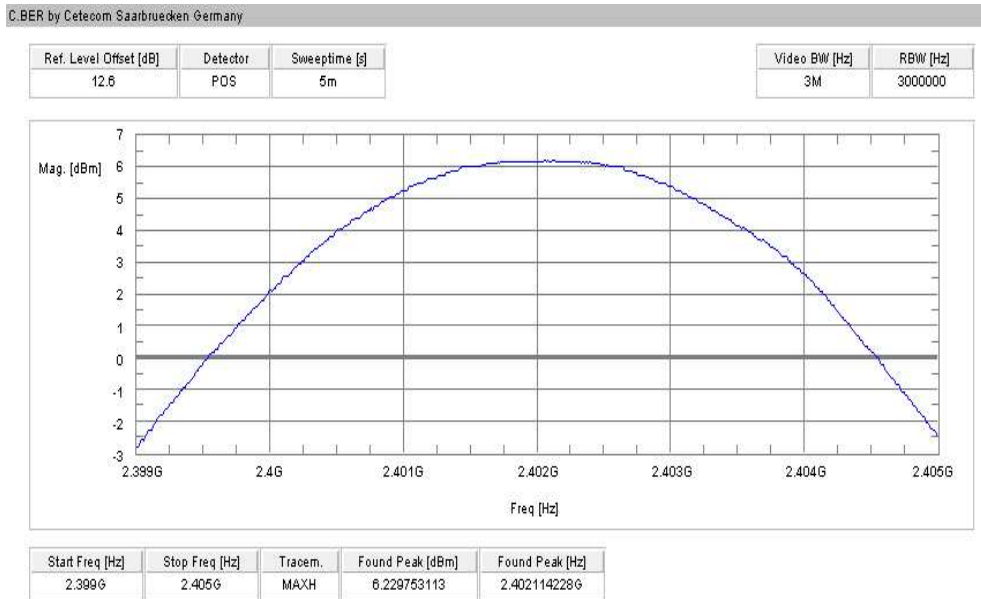

Plot 2: Channel 39 / GFSK (conducted)

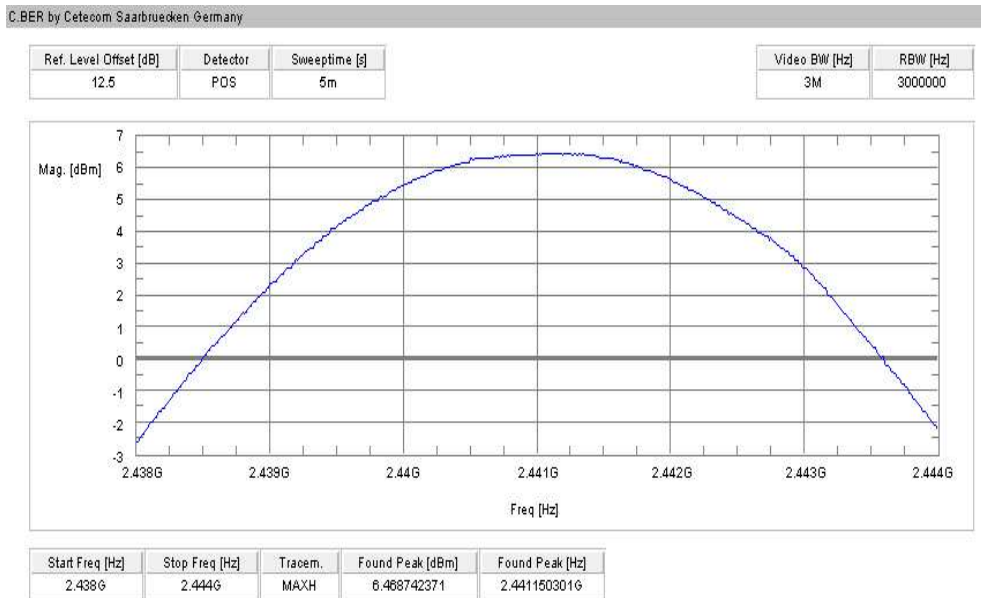

Plot 3: Channel 78 / GFSK (conducted)

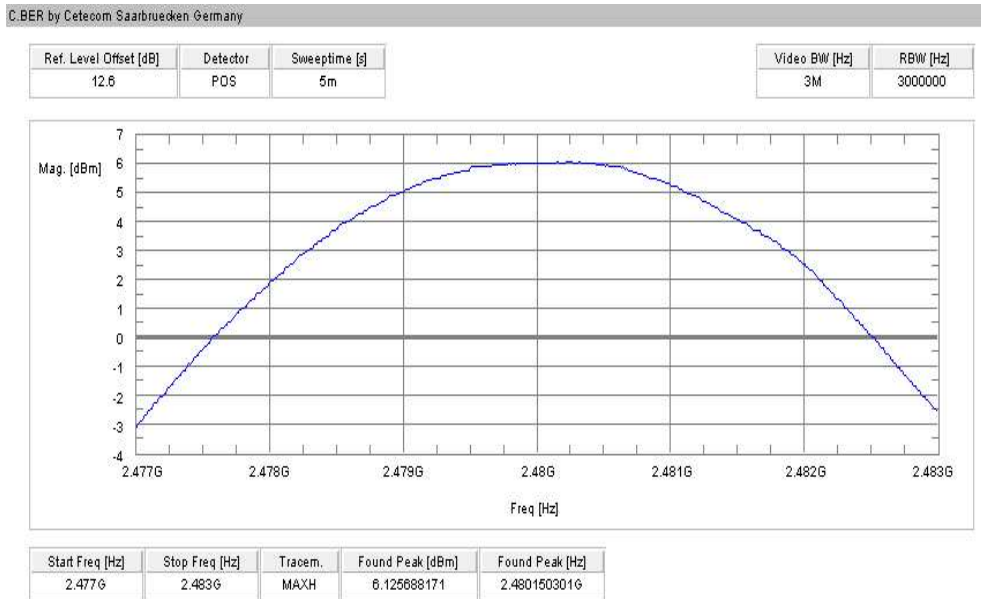

Plot 4: Channel 00 / Pi/4 DQPSK (conducted)

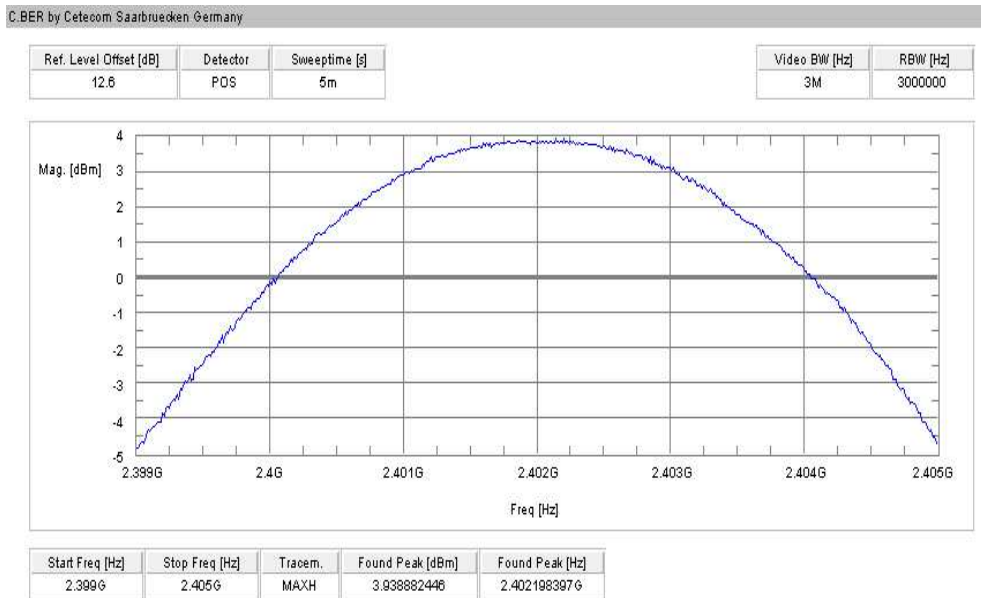

Plot 5: Channel 39 / Pi/4 DQPSK (conducted)

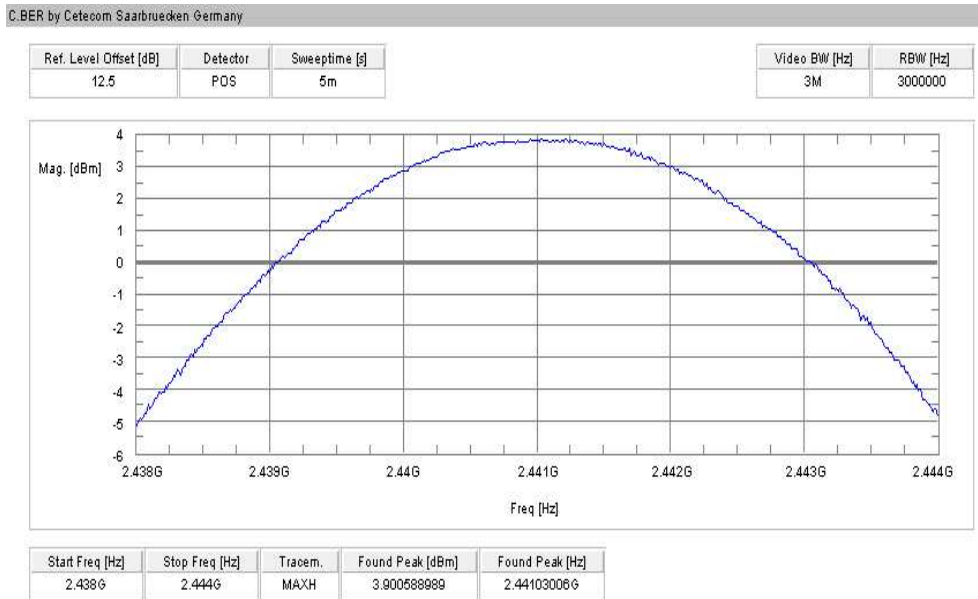

Plot 6: Channel 78 / Pi/4 DQPSK (conducted)

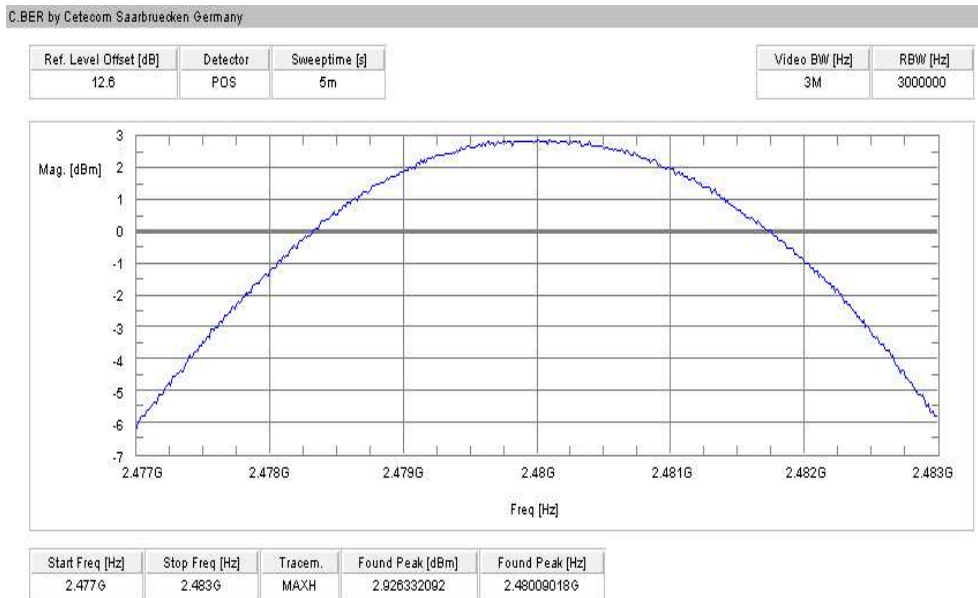

Plot 7: Channel 00 / 8DPSK (conducted)

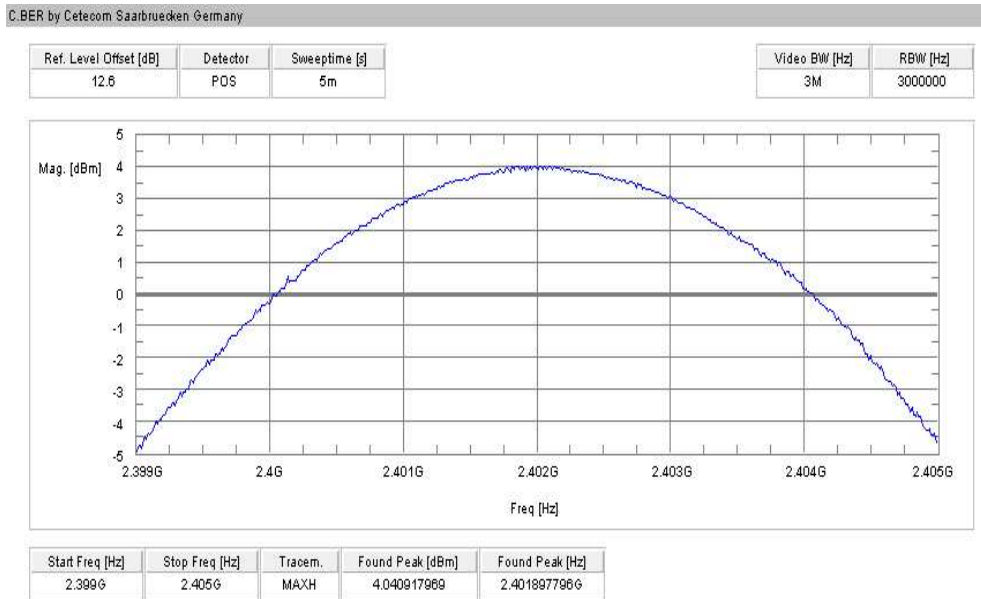

Plot 8: Channel 39 / 8DPSK (conducted)

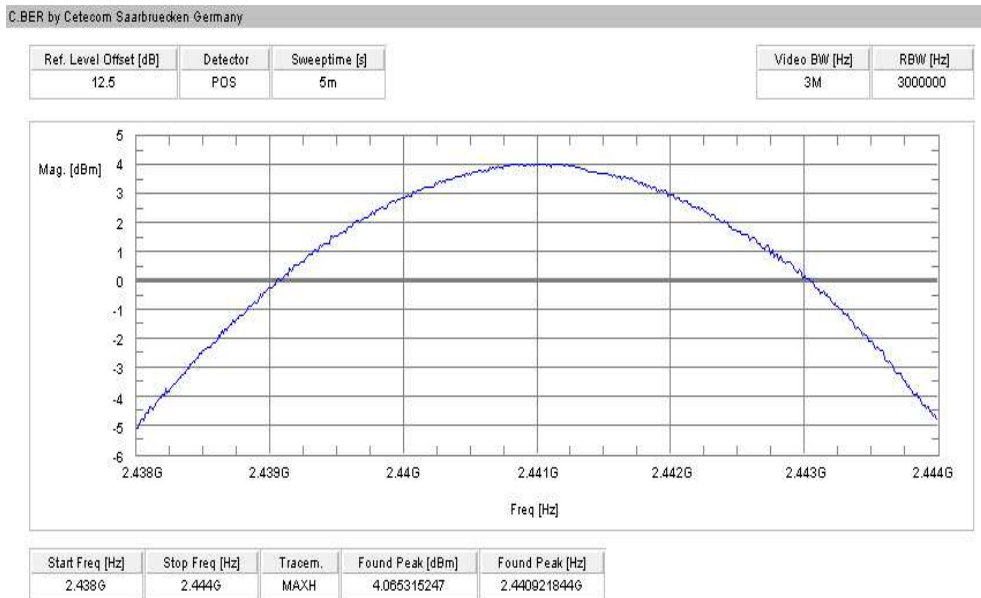

Plot 9: Channel 78 / 8DPSK (conducted)

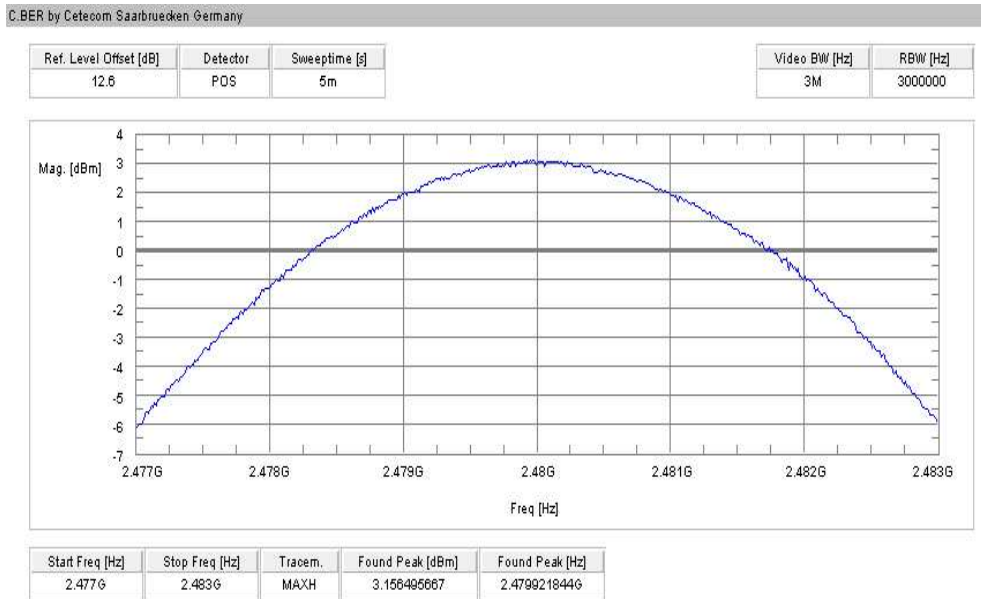

9.8 Band edge compliance conducted

Description:

Measurement of the conducted band edge compliance. EUT is measured at the lower and upper band edge in single channel and hopping mode. The measurement is repeated for all modulations.

Measurement:

Measurement parameter	
Detector:	Peak
Sweep time:	Auto
Video bandwidth:	100 kHz
Resolution bandwidth:	100 kHz
Span:	Lower Band Edge: 2395 – 2405 MHz higher Band Edge: 2478 – 2489 MHz
Trace-Mode:	Max Hold

Limits:

FCC	IC
CFR Part 15.247 (d)	RSS 210, Issue 7, A 8.5
Band edge compliance conducted	
<p>In any 100 kHz bandwidth outside the frequency band in which the spread spectrum or digitally modulated intentional radiator is operating, the radio frequency power that is produced by the intentional radiator shall be at least 20 dB below that in the 100 kHz bandwidth within the band that contains the highest level of the desired power, based on either an RF conducted or a radiated measurement. Attenuation below the general limits specified in Section 15.209(a) is not required.</p>	

Result: Also see plots

Szenario Modulation	Band edge compliance conducted [dB]		
	GFSK	Pi/4 DQPSK	8DPSK
Lower band edge – hopping off	> 20 dB	> 20 dB	> 20 dB
Lower band edge – hopping on	> 20 dB	> 20 dB	> 20 dB
Upper band edge – hopping off	> 20 dB	> 20 dB	> 20 dB
Upper band edge – hopping on	> 20 dB	> 20 dB	> 20 dB
Measurement uncertainty	± 1.5 dB		

Result: The result of the measurement is passed.

Plot 1: Lower band edge – hopping on / GFSK (conducted)



Plot 2: Upper band edge – hopping on / GFSK (conducted)

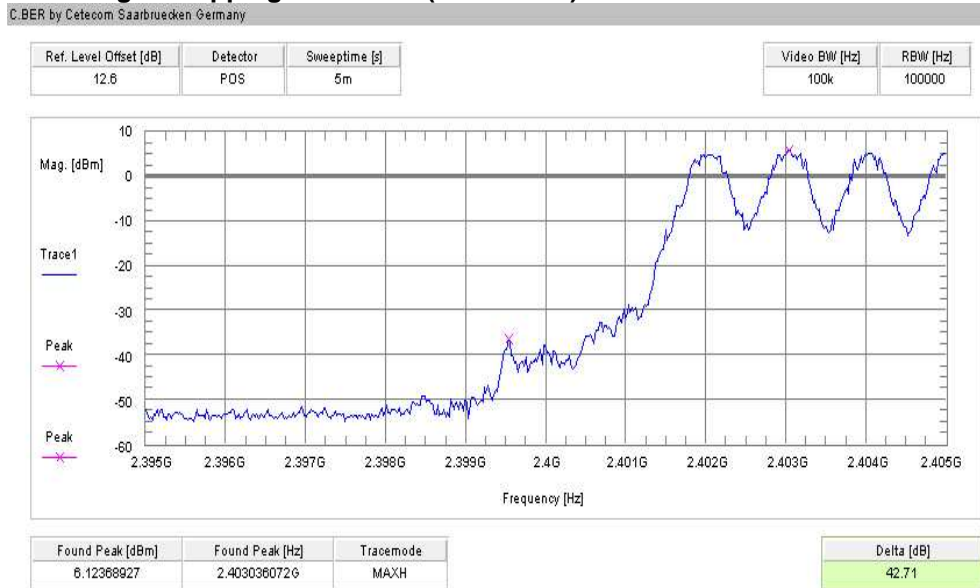

Plot 3: Lower band edge – hopping off / GFSK (conducted)

C.BER by Cetecom Saarbruecken Germany

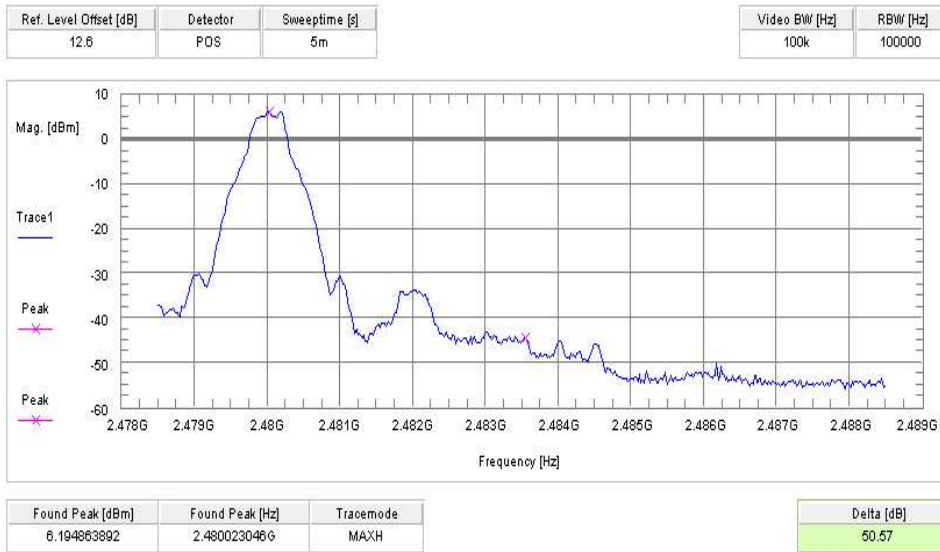

Plot 4: Upper band edge – hopping off / GFSK (conducted)

C.BER by Cetecom Saarbruecken Germany

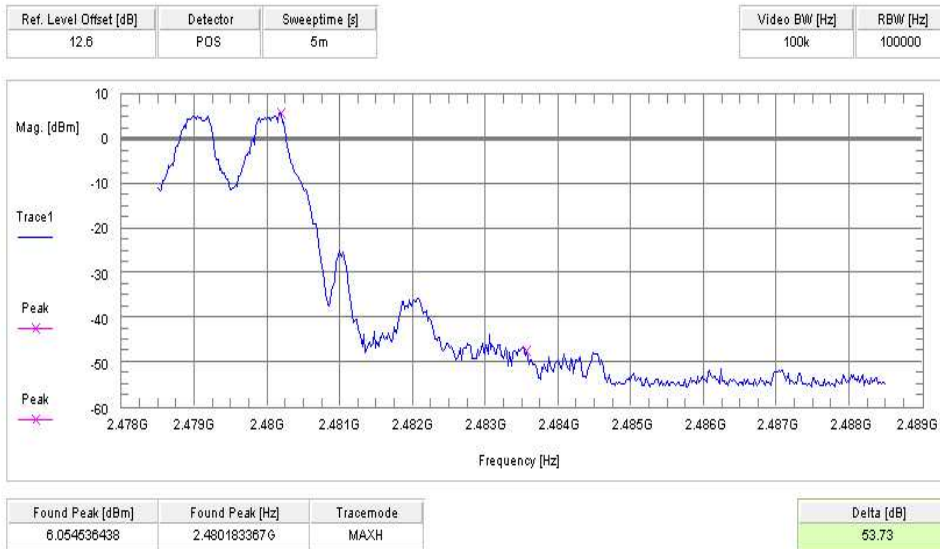

Plot 5: Lower band edge – hopping on / Pi/4 DQPSK (conducted)

C.BER by Cetecom Saarbruecken Germany

Ref. Level Offset [dB]	Detector	Sweeptime [s]	Video BW [Hz]	RBW [Hz]
12.6	POS	5m	100k	100000

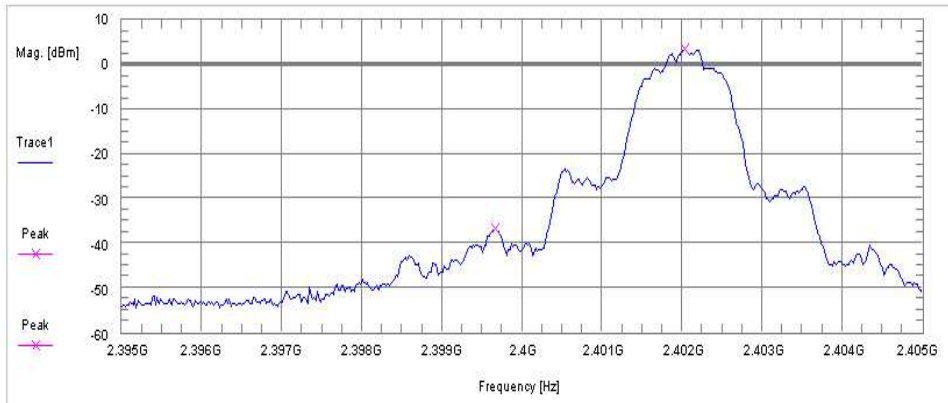

Found Peak [dBm]	Found Peak [Hz]	Tracemode	Delta [dB]
3.449311829	2.402034068G	MAXH	40.23

Plot 6: Upper band edge – hopping on / Pi/4 DQPSK (conducted)

C.BER by Cetecom Saarbruecken Germany

Ref. Level Offset [dB]	Detector	Sweeptime [s]	Video BW [Hz]	RBW [Hz]
12.6	POS	5m	100k	100000

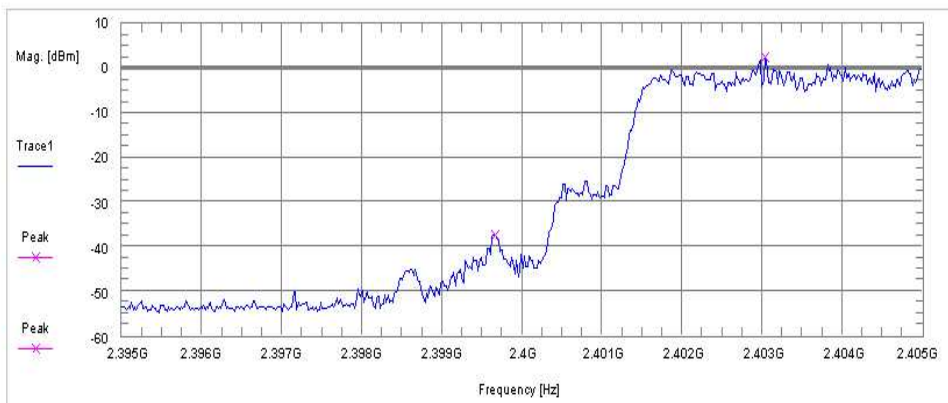

Found Peak [dBm]	Found Peak [Hz]	Tracemode	Delta [dB]
2.460738525	2.403036072G	MAXH	38.85

Plot 7: Lower band edge – hopping off / Pi/4 DQPSK (conducted)

C.BER by Cetecom Saarbruecken Germany

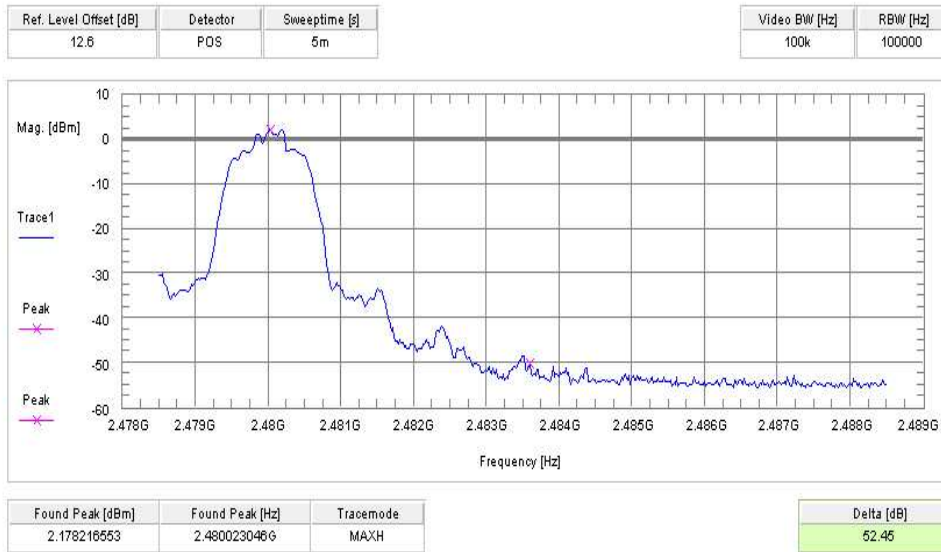

Plot 8: Upper band edge – hopping off / Pi/4 DQPSK (conducted)

C.BER by Cetecom Saarbruecken Germany

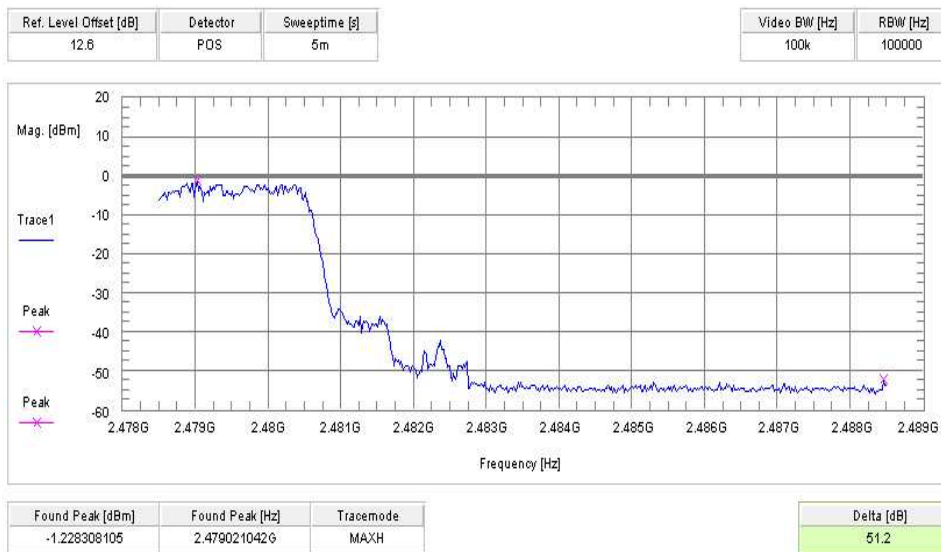

Plot 9: Lower band edge – hopping on / 8DPSK (conducted)

C.BER by Cetecom Saarbruecken Germany

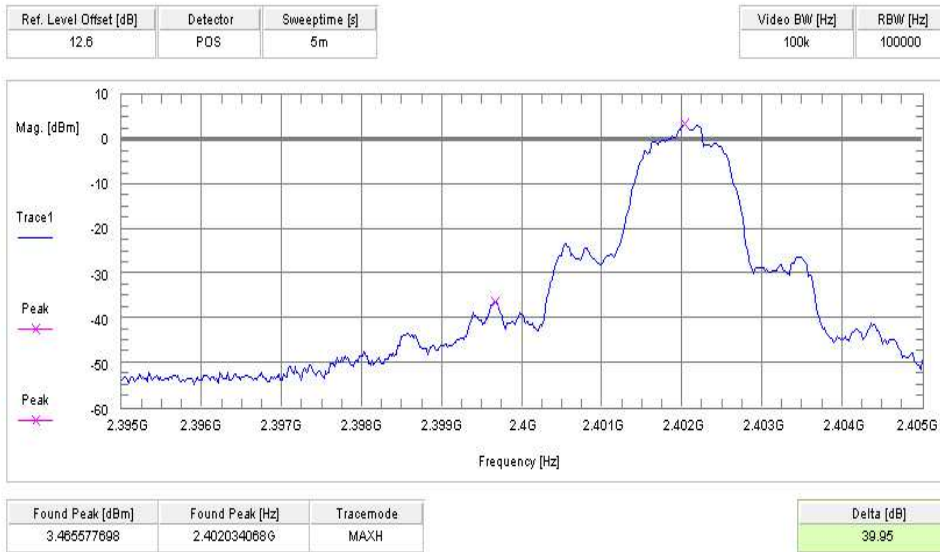

Plot 10: Upper band edge – hopping on / 8DPSK (conducted)

C.BER by Cetecom Saarbruecken Germany

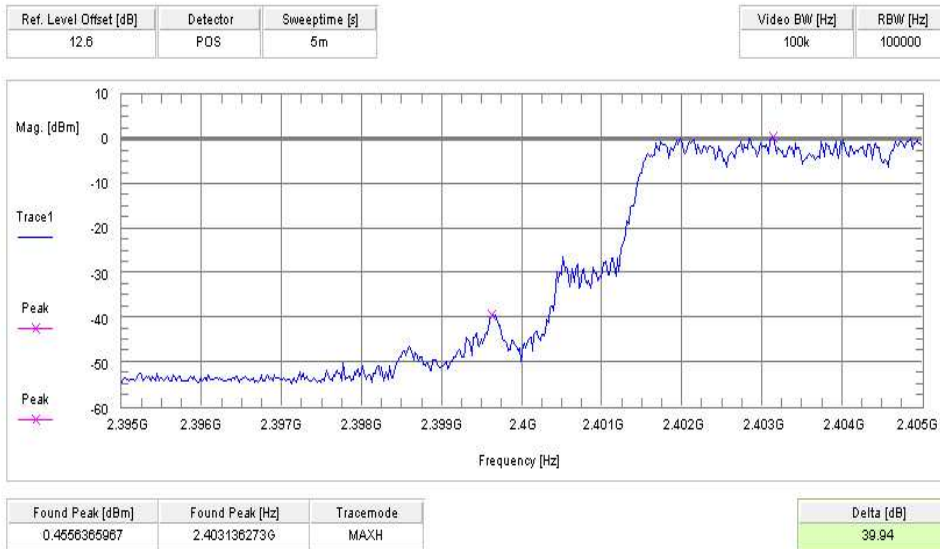

Plot 11: Lower band edge – hopping off / 8DPSK (conducted)

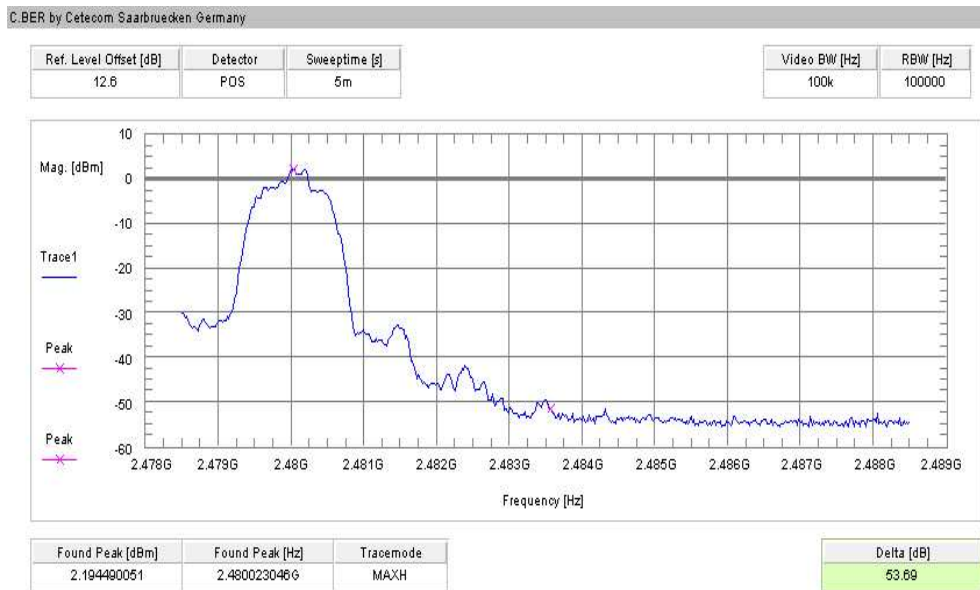

Plot 12: Upper band edge – hopping off / 8DPSK (conducted)

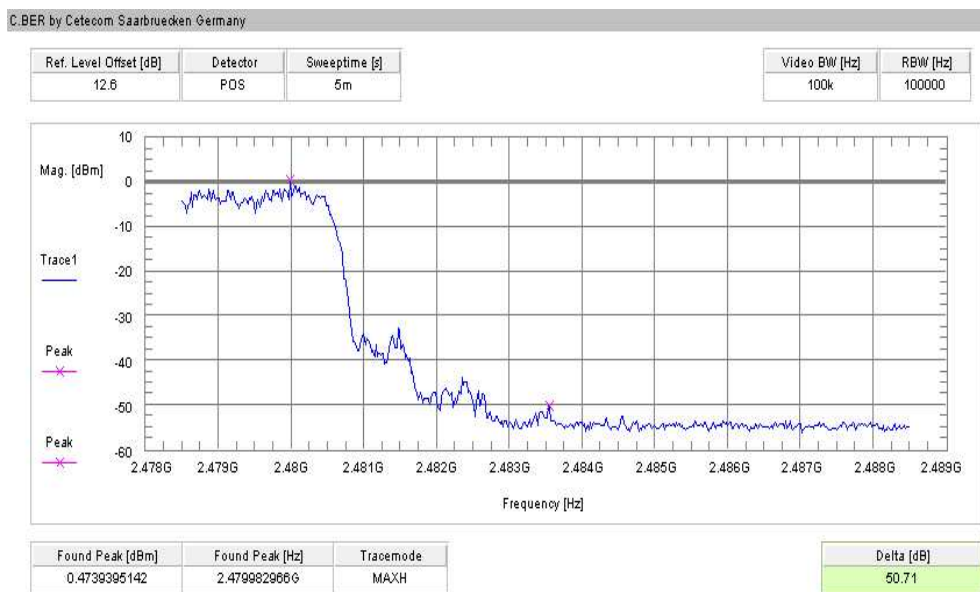

9.9 Band edge compliance radiated

Description:

Measurement of the radiated band edge compliance. The EUT is turned in the position that results in the maximum level at the band edge. Then a sweep over the corresponding restricted band is performed. The EUT is set to single channel mode and the transmit channel is channel 00 for the lower restricted band and channel 78 for the upper restricted band. The measurement is repeated for all modulations. Measurement distance is 3m.

Measurement:

Measurement parameter	
Detector:	Peak
Sweep time:	Auto
Video bandwidth:	10 Hz
Resolution bandwidth:	1 MHz
Span:	Lower Band: 2300 – 2400 MHz higher Band: 2480 – 2500 MHz
Trace-Mode:	Max Hold

Limits:

FCC	IC
CFR Part 15.205	RSS 210, Issue 7, A 8.5
Band edge compliance radiated	
<p>In any 100 kHz bandwidth outside the frequency band in which the spread spectrum or digitally modulated intentional radiator is operating, the radio frequency power that is produced by the intentional radiator shall be at least 20 dB below that in the 100 kHz bandwidth within the band that contains the highest level of the desired power, based on either an RF conducted or a radiated measurement. Attenuation below the general limits specified in Section 15.209(a) is not required. In addition, radiated emissions which fall in the restricted bands, as defined in Section 15.205(a), must also comply with the radiated emission limits specified in Section 15.209(a) (see Section 5.205(c)).</p>	
54 dBµV/m AVG	

Result: Also see plots

Szenario Modulation	Band edge compliance radiated [dB μ V/m]		
	GFSK	Pi/4 DQPSK	8DPSK
Lower restricted band	< 54 (see plot 1)	< 54 (see plot 3)	< 54 (see plot 5)
Upper restricted band	< 54 (see plot 2)	< 54 (see plot 4)	< 54 (see plot 6)
Measurement uncertainty	± 3 dB		

Result: The result of the measurement is passed.

Plot 1: Lower Restricted Band / GFSK (radiated) (vertical/horizontal – max hold)

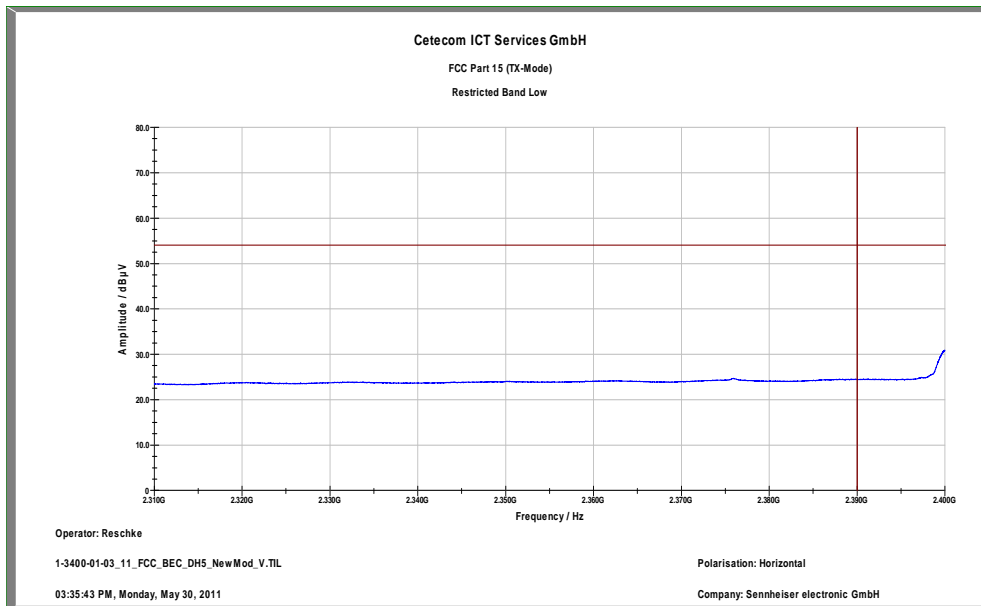

Plot 2: Upper Restricted Band / GFSK (radiated) (vertical/horizontal – max hold)



Plot 3: Lower Restricted Band / Pi/4 DQPSK (radiated) (vertical/horizontal – max hold)

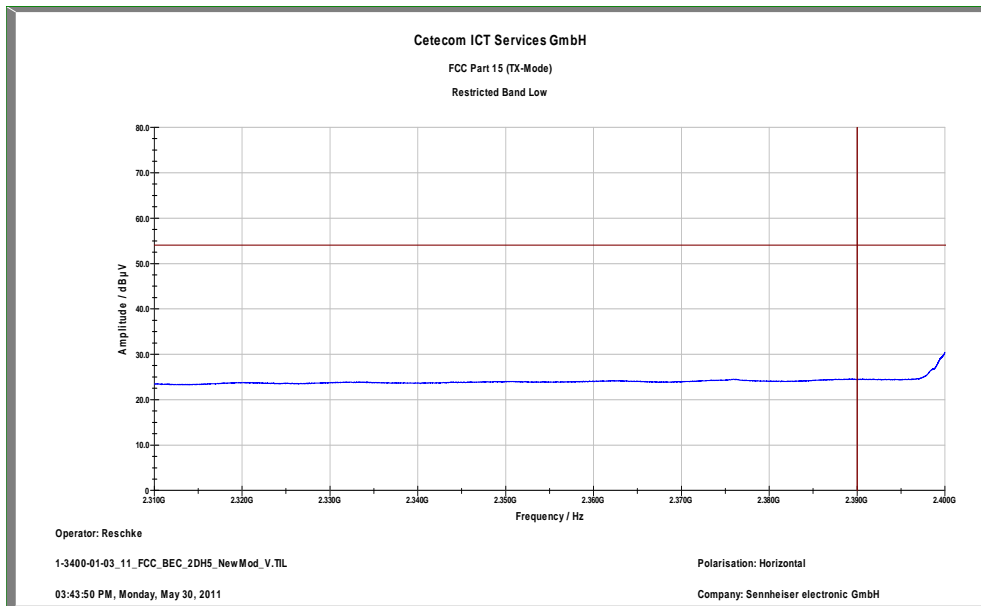

Plot 4: Upper Restricted Band / Pi/4 DQPSK (radiated) (vertical/horizontal – max hold)



Plot 5: Lower Restricted Band / 8DPSK (radiated) (vertical/horizontal – max hold)

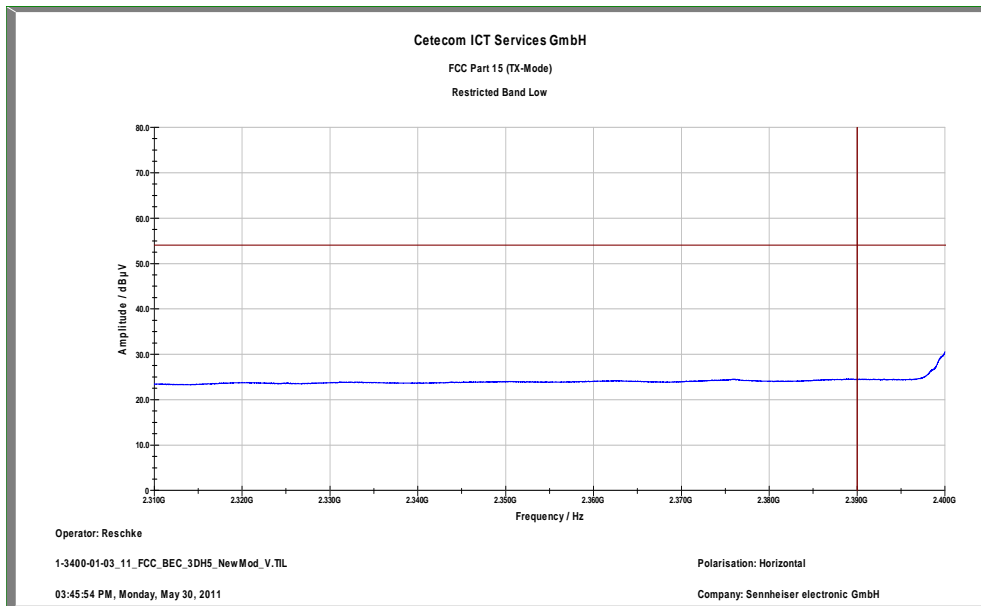

Plot 6: Upper Restricted Band / 8DPSK (radiated) (vertical/horizontal – max hold)



9.10 TX spurious emissions conducted

Description:

Measurement of the conducted spurious emissions in transmit mode. The EUT is set to single channel mode and the transmit channel is channel 00, channel 39 and channel 78. The measurement is repeated for all modulations.

Measurement:

Measurement parameter	
Detector:	Peak
Sweep time:	Auto
Video bandwidth:	F < 1 GHz: 100 kHz F > 1 GHz: 1 MHz
Resolution bandwidth:	F < 1 GHz: 100 kHz F > 1 GHz: 1 MHz
Span:	9 kHz to 25 GHz
Trace-Mode:	Max Hold

Limits:

FCC	IC
CFR Part 15.247(d)	RSS 210, Issue 7, A 8.5
TX spurious emissions conducted	
<p>In any 100 kHz bandwidth outside the frequency band in which the spread spectrum or digitally modulated intentional radiator is operating, the radio frequency power that is produced by the intentional radiator shall be at least 20 dB below that in the 100 kHz bandwidth within the band that contains the highest level of the desired power, based on either an RF conducted or a radiated measurement. Attenuation below the general limits specified in Section 15.209(a) is not required</p>	

Result: Also see plots

TX spurious emissions conducted					
GFSK - mode					
f [MHz]		amplitude of emission [dBm]	limit max. allowed emission power	actual attenuation below frequency of operation [dB]	results
2402			30 dBm		Operating frequency
		<i>No critical peaks found</i>			complies
			-20 dBc		
2441			30 dBm		Operating frequency
		<i>No critical peaks found</i>			complies
			-20 dBc		
2480			30 dBm		Operating frequency
		<i>No critical peaks found</i>			complies
			-20 dBc		
Measurement uncertainty			± 3 dB		

TX spurious emissions conducted					
Pi/4-DQPSK - mode					
f [MHz]		amplitude of emission [dBm]	limit max. allowed emission power	actual attenuation below frequency of operation [dB]	results
2402			30 dBm		Operating frequency
		<i>No critical peaks found</i>			complies
			-20 dBc		
2441			30 dBm		Operating frequency
		<i>No critical peaks found</i>			complies
			-20 dBc		
2480			30 dBm		Operating frequency
		<i>No critical peaks found</i>			complies
			-20 dBc		
Measurement uncertainty			± 3dB		

TX spurious emissions conducted					
8DPSK - mode					
f [MHz]		amplitude of emission [dBm]	limit max. allowed emission power	actual attenuation below frequency of operation [dB]	results
2402			30 dBm		Operating frequency
<i>No critical peaks found</i>			-20 dBc		complies
2441			30 dBm		Operating frequency
<i>No critical peaks found</i>			-20 dBc		complies
2480			30 dBm		Operating frequency
<i>No critical peaks found</i>			-20 dBc		complies
Measurement uncertainty		± 3dB			

Result: The result of the measurement is passed.

Plot 1: Channel 00 / GFSK

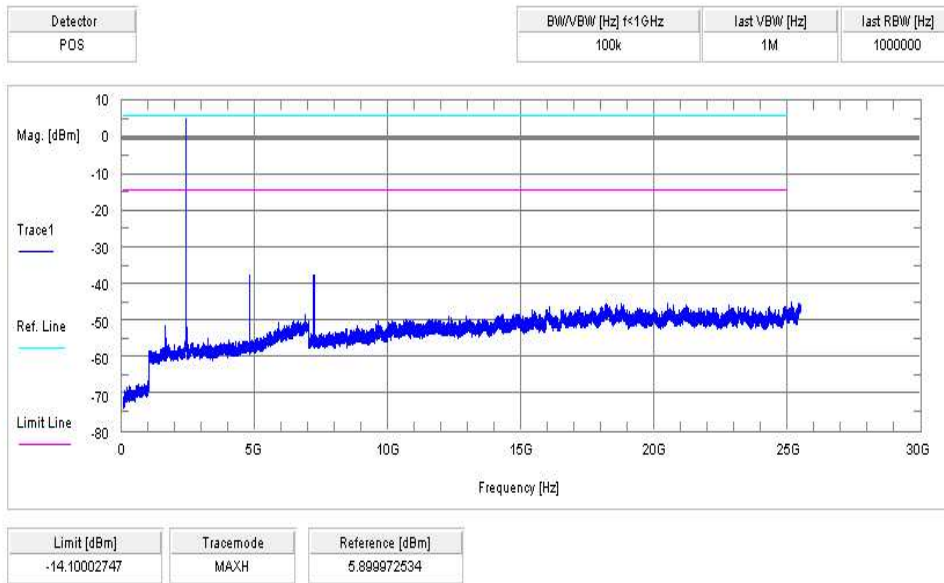

Plot 2: Channel 39 / GFSK

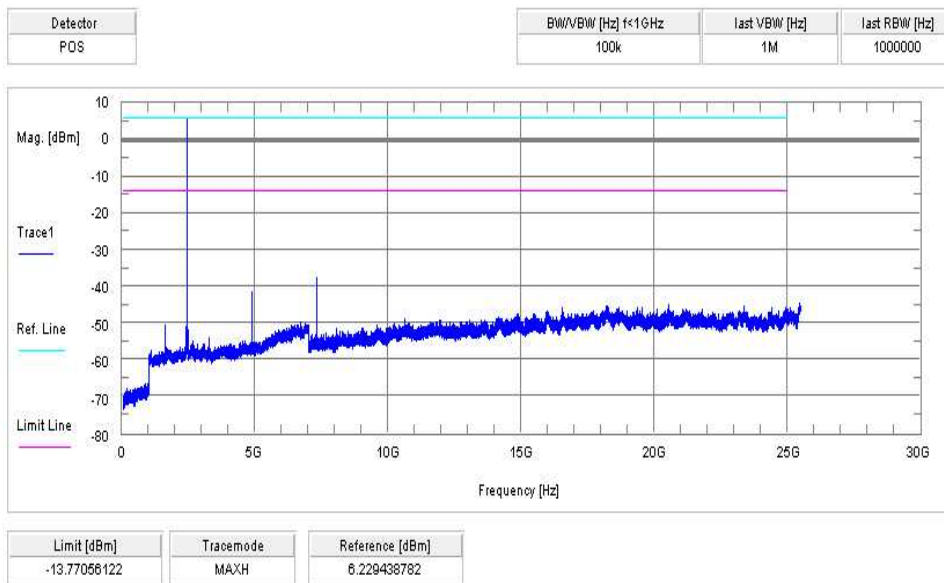

Plot 3: Channel 78 / GFSK

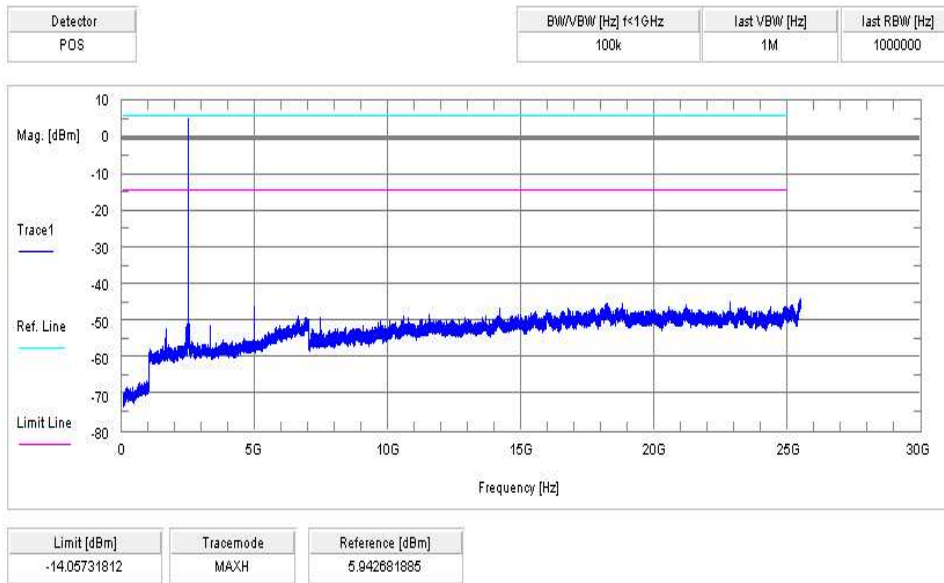

Plot 4: Channel 00 / Pi/4 DQPSK

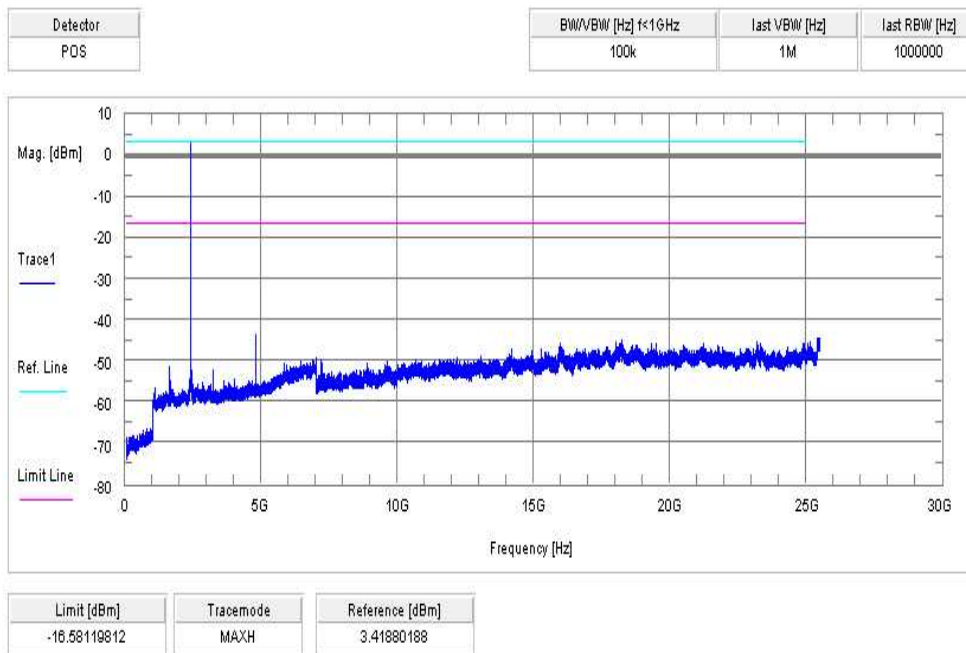

Plot 5: Channel 39 / Pi/4 DQPSK

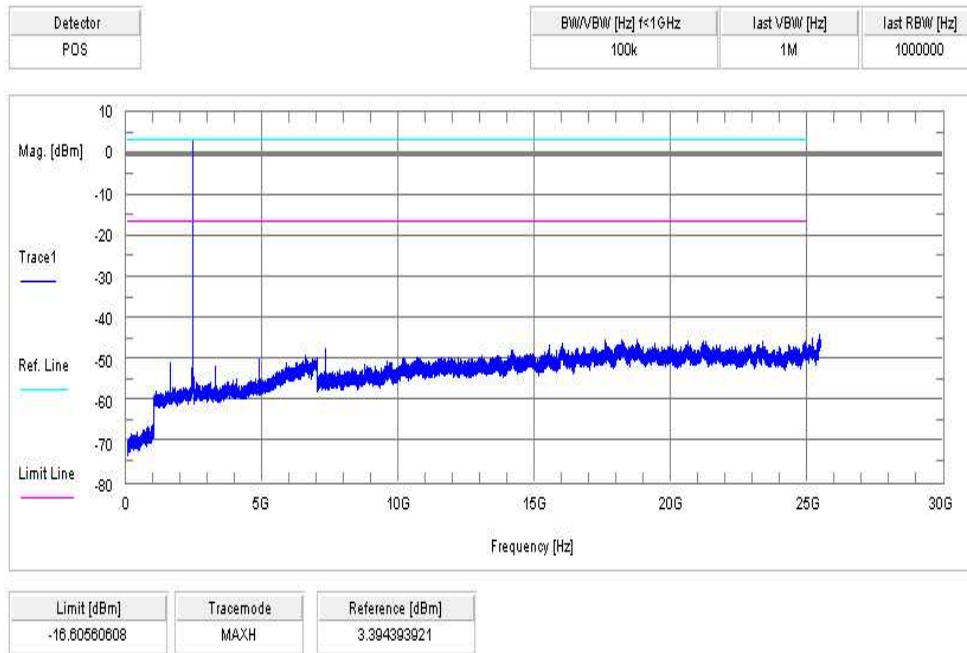

Plot 6: Channel 78 / Pi/4 DQPSK

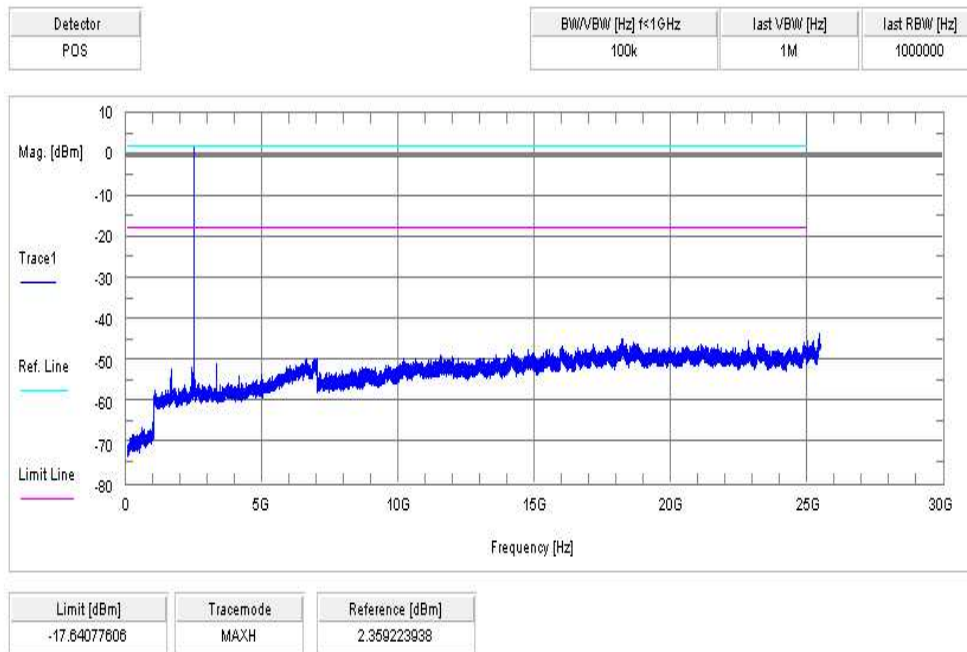

Plot 7: Channel 00 / 8DPSK

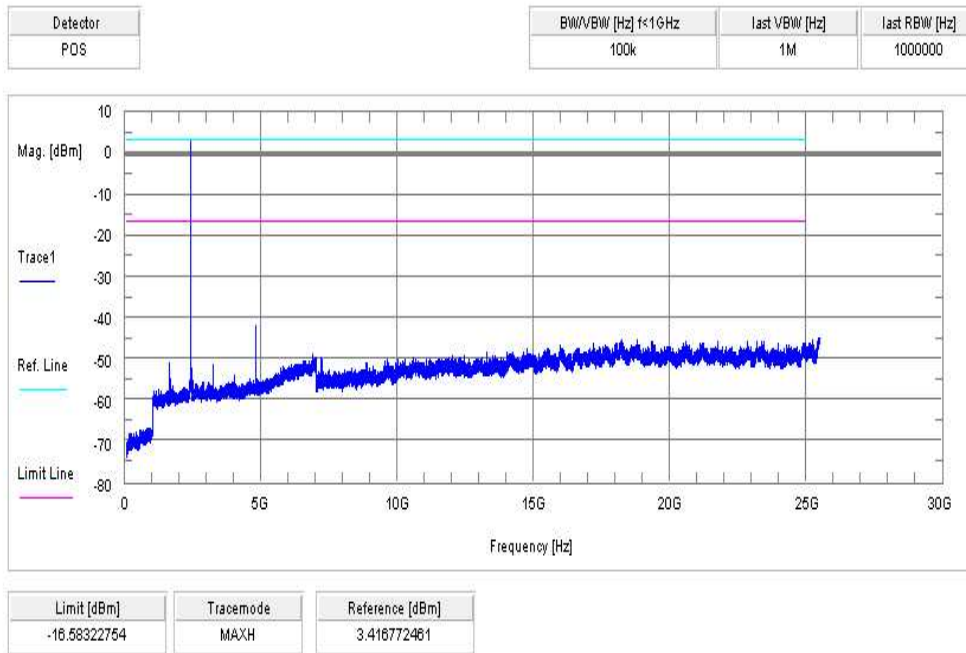

Plot 8: Channel 00 / 8DPSK

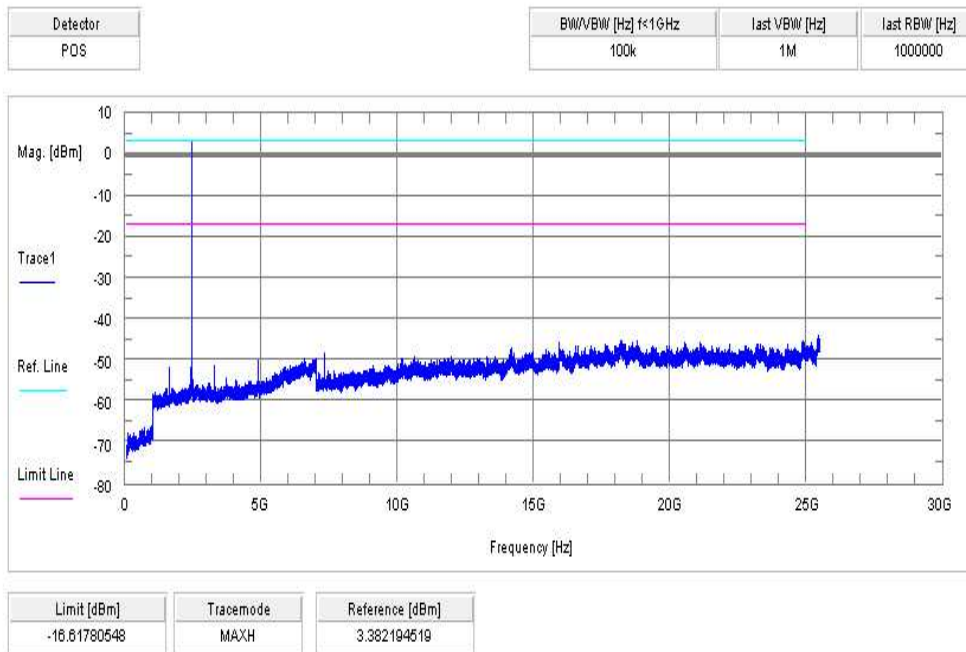

Plot 9: Channel 00 / 8DPSK

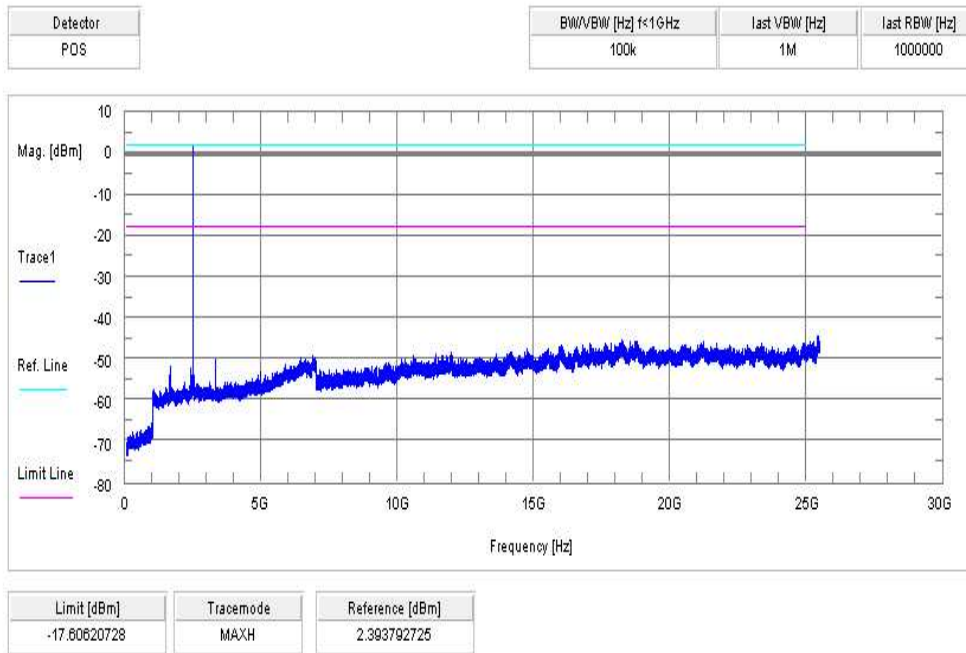

9.11 TX spurious emissions radiated

Description:

Measurement of the radiated spurious emissions in transmit mode. The EUT is set to single channel mode and the transmit channel is channel 00, channel 39 and channel 78. The measurement is performed in the mode with the highest output power.

Measurement:

Measurement parameter	
Detector:	Peak / Quasi Peak
Sweep time:	Auto
Video bandwidth:	Sweep: 100 kHz Remeasurement: 10 Hz
Resolution bandwidth:	F < 1 GHz: 100 kHz F > 1 GHz: 1 MHz
Span:	30 MHz to 25 GHz
Trace-Mode:	Max Hold
Measured Modulation:	<input checked="" type="checkbox"/> GFSK <input type="checkbox"/> Pi/4 DQPSK <input type="checkbox"/> 8DPSK

The modulation with the highest output power was used to perform the transmitter spurious emissions. If spurious were detected a re-measurement was performed on the detected frequency with each modulation.

Limits:

FCC		IC	
CFR Part 15.247(d)		RSS 210, Issue 7, A 8.5	
TX spurious emissions radiated			
<p>In any 100 kHz bandwidth outside the frequency band in which the spread spectrum or digitally modulated intentional radiator is operating, the radio frequency power that is produced by the intentional radiator shall be at least 20 dB below that in the 100 kHz bandwidth within the band that contains the highest level of the desired power, based on either an RF conducted or a radiated measurement. Attenuation below the general limits specified in Section 15.209(a) is not required. In addition, radiated emissions which fall in the restricted bands, as defined in §15.205(a), must also comply with the radiated emission limits specified in §15.209(a) (see §15.205(c)).</p>			
§15.209			
Frequency (MHz)	Field strength (dBµV/m)	Measurement distance	
30 - 88	30.0	10	
88 – 216	33.5	10	
216 – 960	36.0	10	
Above 960	54.0	3	

Result: Also see plots

TX spurious emissions radiated [dBµV/m]								
2402 MHz			2441 MHz			2480 MHz		
F [MHz]	Detector	Level [dBµV/m]	F [MHz]	Detector	Level [dBµV/m]	F [MHz]	Detector	Level [dBµV/m]
1602	AV	36.07	1632	AV	35.88	1652	AV	35.96
4804	AV	41.93	4882	AV	38.98	1654	AV	35.90
7206	AV	26.68	7323	AV	26.70	4960	AV	33.76
						7440	AV	26.60
Measurement uncertainty			± 3 dB					

AV) RBW = 1 MHz / VBW = 10 Hz

Result: The result of the measurement is passed.

Plot 1: 30 MHz to 1 GHz / channel 00 (horizontal/vertical)

Common Information

EUT: S1 digital
 Serial Number: prototype
 Test Description: FCC Part 15 C < 1 GHz @ 10m
 Operating Conditions: BT TX Ch: 00
 Operator Name: Langer
 Comment: DC 3V

Scan Setup: STAN_Fin [EMI radiated]

Hardware Setup: Electric Field (NOS)
 Level Unit: dBµV/m
Subrange **Detectors** **IF Bandwidth** **Meas. Time** **Receiver**
 30 MHz - 2 GHz QuasiPeak 120 kHz 15 s Receiver

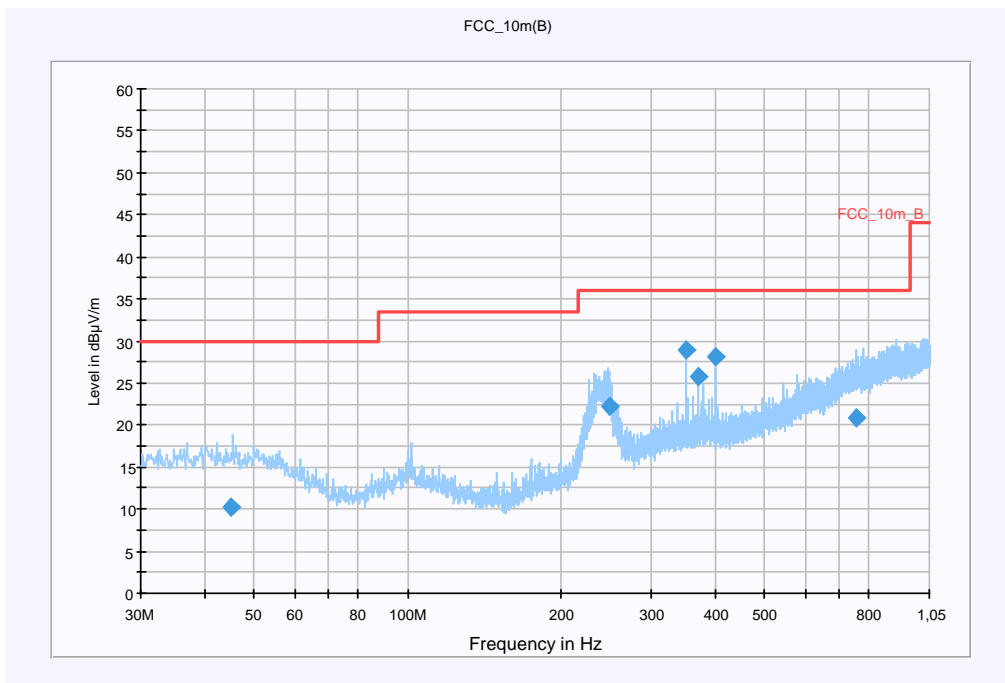

Final Result 1

Frequency (MHz)	QuasiPeak (dBµV/m)	Meas. Time (ms)	Bandwidth (kHz)	Antenna height (cm)	Polarity	Turntable position (deg)	Corr. (dB)	Margin (dB)	Limit (dBµV/m)	Comment
45.086400	10.2	15000.000	120.000	393.0	H	277.0	13.3	19.8	30.0	
247.661700	22.3	15000.000	120.000	200.0	V	29.0	13.2	13.7	36.0	
349.998150	28.9	15000.000	120.000	230.0	H	273.0	16.1	7.1	36.0	
370.833600	25.8	15000.000	120.000	238.0	H	271.0	16.4	10.2	36.0	
400.009350	28.0	15000.000	120.000	259.0	H	88.0	16.9	8.0	36.0	
756.038850	20.9	15000.000	120.000	100.0	H	294.0	23.7	15.1	36.0	

Plot 2: 1 GHz to 12.75 GHz / channel 00 (horizontal/vertical)

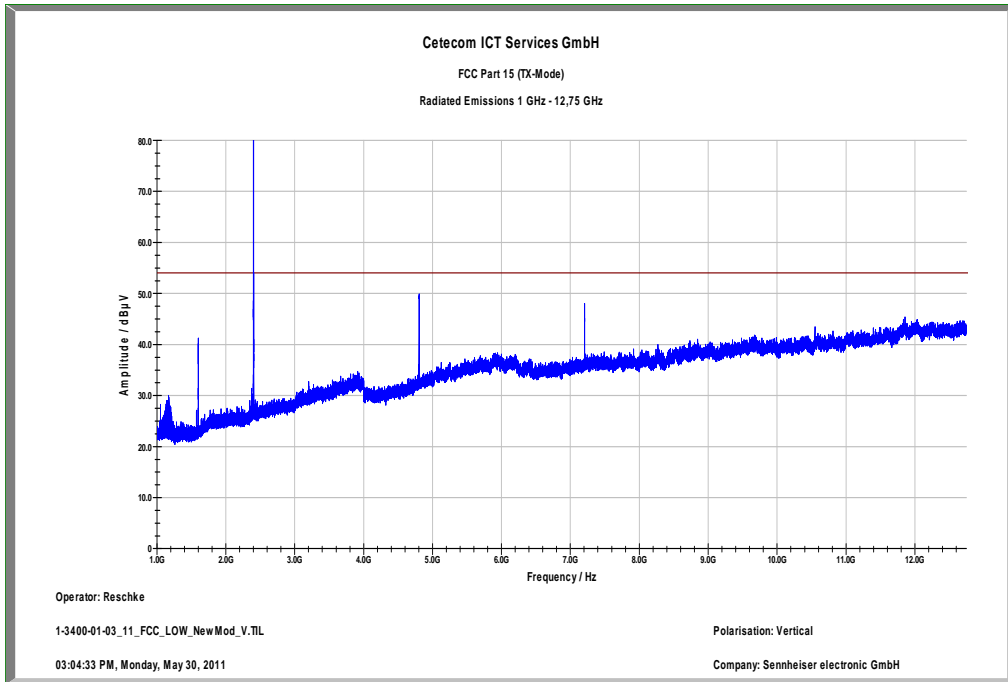

Plot 3: 12 GHz to 25 GHz / channel 00 (horizontal/vertical) – valid for all channels

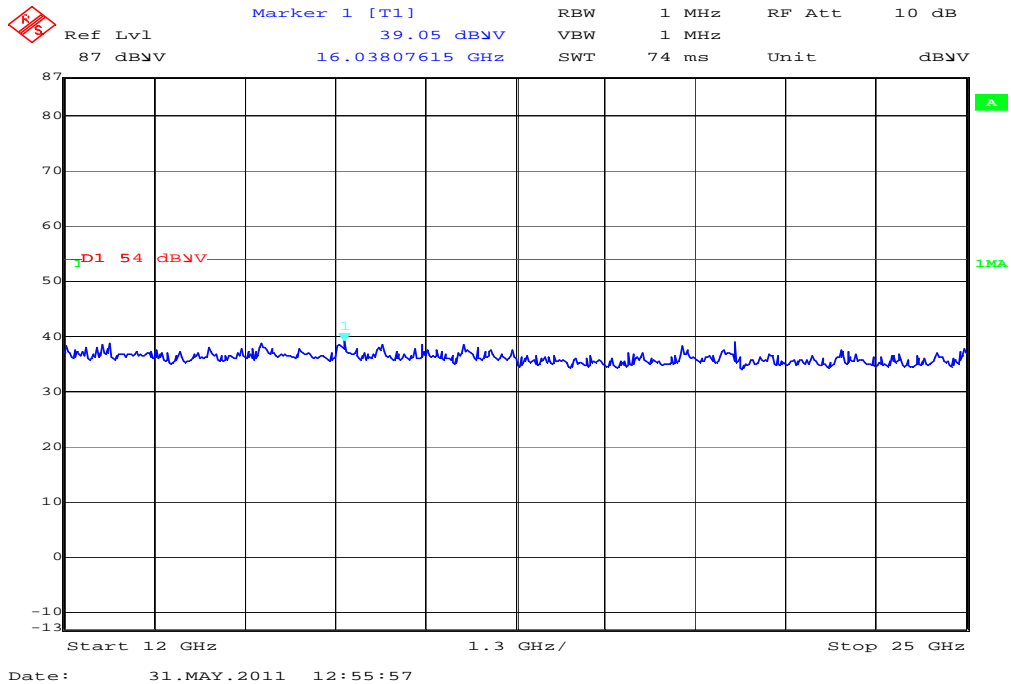

Plot 4: 30 MHz to 1 GHz / channel 39 (horizontal/vertical)

Common Information

EUT: S1 digital
 Serial Number: prototype
 Test Description: FCC Part 15 C < 1 GHz @ 10m
 Operating Conditions: BT TX Ch: 39
 Operator Name: Langer
 Comment: DC 3V

Scan Setup: STAN_Fin [EMI radiated]

Hardware Setup: Electric Field (NOS)
 Level Unit: dBµV/m
Subrange **Detectors** **IF Bandwidth** **Meas. Time** **Receiver**
 30 MHz - 2 GHz QuasiPeak 120 kHz 15 s Receiver

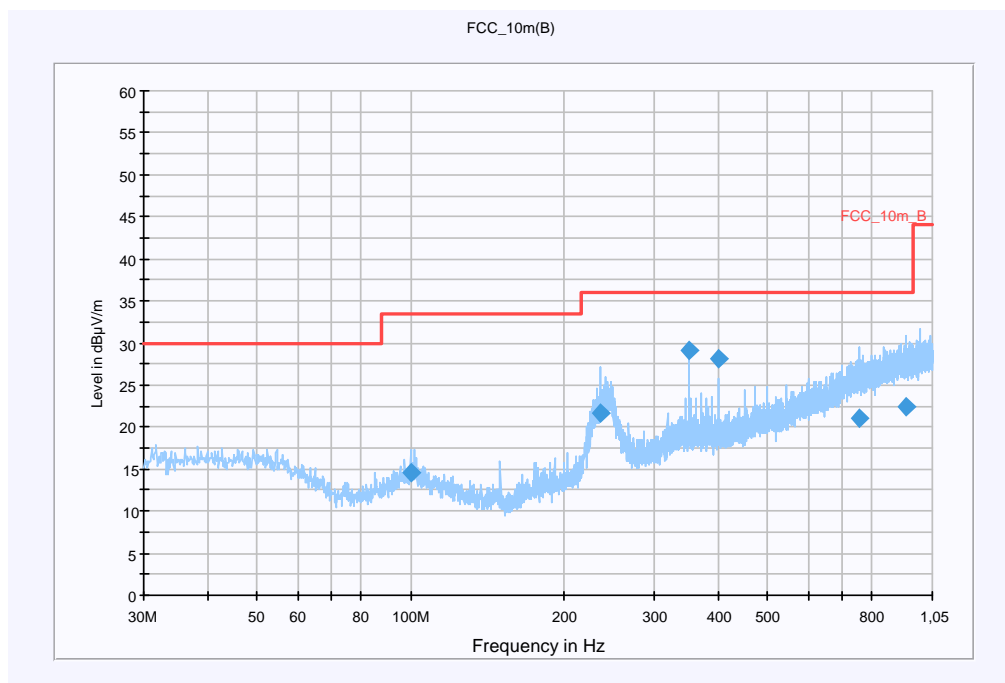

Final Result 1

Frequency (MHz)	QuasiPeak (dBµV/m)	Meas. Time (ms)	Bandwidth (kHz)	Antenna height (cm)	Polarity	Turntable position (deg)	Corr. (dB)	Margin (dB)	Limit (dBµV/m)	Comment
100.023600	14.5	15000.000	120.000	354.0	V	227.0	11.9	19.0	33.5	
234.897600	21.7	15000.000	120.000	107.0	V	219.0	12.9	14.3	36.0	
349.981650	29.1	15000.000	120.000	226.0	H	275.0	16.1	6.9	36.0	
399.998700	28.0	15000.000	120.000	200.0	H	282.0	16.9	8.0	36.0	
753.473100	21.1	15000.000	120.000	377.0	V	337.0	23.7	14.9	36.0	
933.766800	22.5	15000.000	120.000	300.0	H	51.0	25.3	13.5	36.0	

Plot 5: 1 GHz to 12.75 GHz / channel 39 (horizontal/vertical)

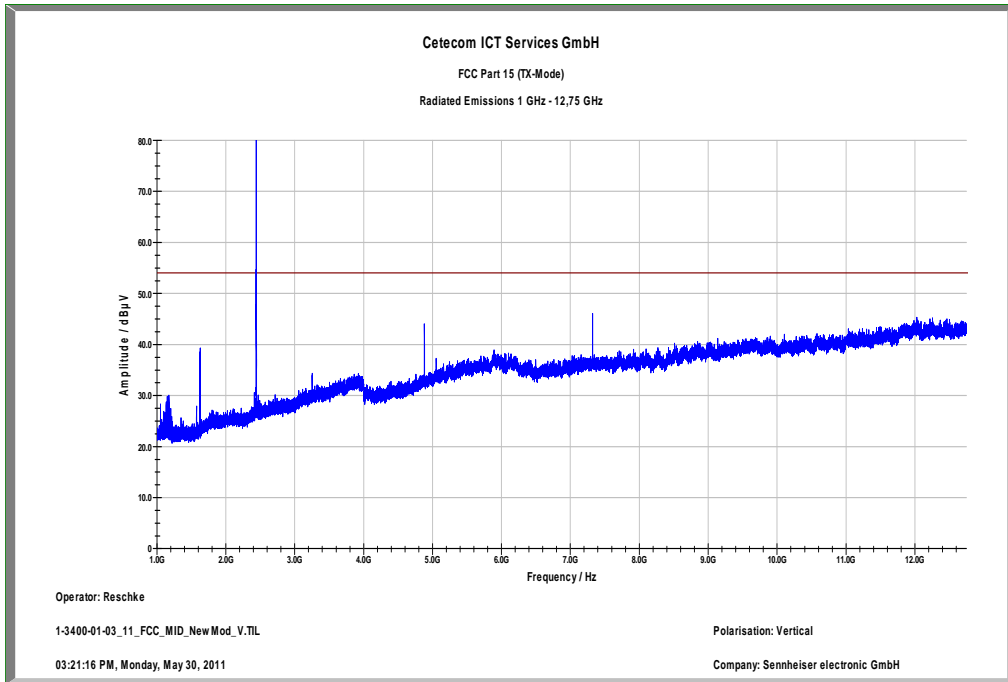

Plot 6: 30 MHz to 1 GHz / channel 78 (horizontal/vertical)

Common Information

EUT: S1 digital
 Serial Number: prototype
 Test Description: FCC Part 15 C < 1 GHz @ 10m
 Operating Conditions: BT TX Ch: 78
 Operator Name: Langer
 Comment: DC 3V

Scan Setup: STAN_Fin [EMI radiated]

Hardware Setup: Electric Field (NOS)
 Level Unit: dBµV/m
Subrange **Detectors** **IF Bandwidth** **Meas. Time** **Receiver**
 30 MHz - 2 GHz QuasiPeak 120 kHz 15 s Receiver

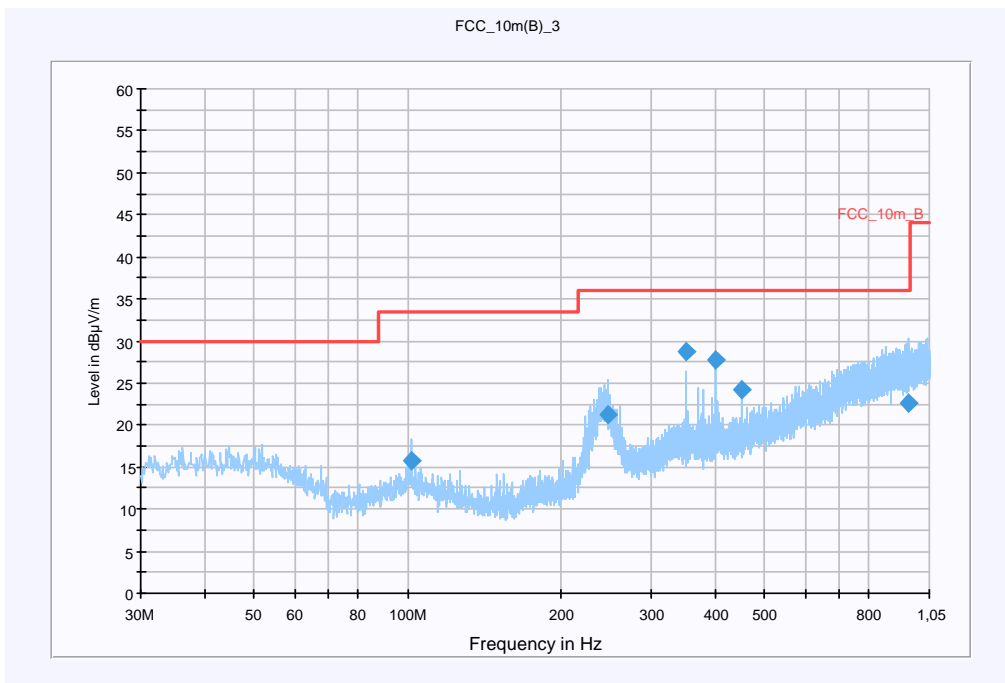

Final Result 1

Frequency (MHz)	QuasiPeak (dBµV/m)	Meas. Time (ms)	Bandwidth (kHz)	Antenna height (cm)	Polarity	Turntable position (deg)	Corr. (dB)	Margin (dB)	Limit (dBµV/m)	Comment
101.683800	15.7	15000.000	120.000	146.0	V	283.0	11.7	17.8	33.5	
246.188700	21.2	15000.000	120.000	98.0	V	196.0	13.2	14.8	36.0	
349.988250	28.6	15000.000	120.000	174.0	H	273.0	16.1	7.4	36.0	
400.012200	27.8	15000.000	120.000	174.0	H	274.0	16.9	8.2	36.0	
449.991150	24.2	15000.000	120.000	174.0	H	95.0	17.7	11.8	36.0	
953.663250	22.6	15000.000	120.000	174.0	V	8.0	25.4	13.4	36.0	

Plot 7: 1 GHz to 12.75 GHz / channel 78 (horizontal/vertical)

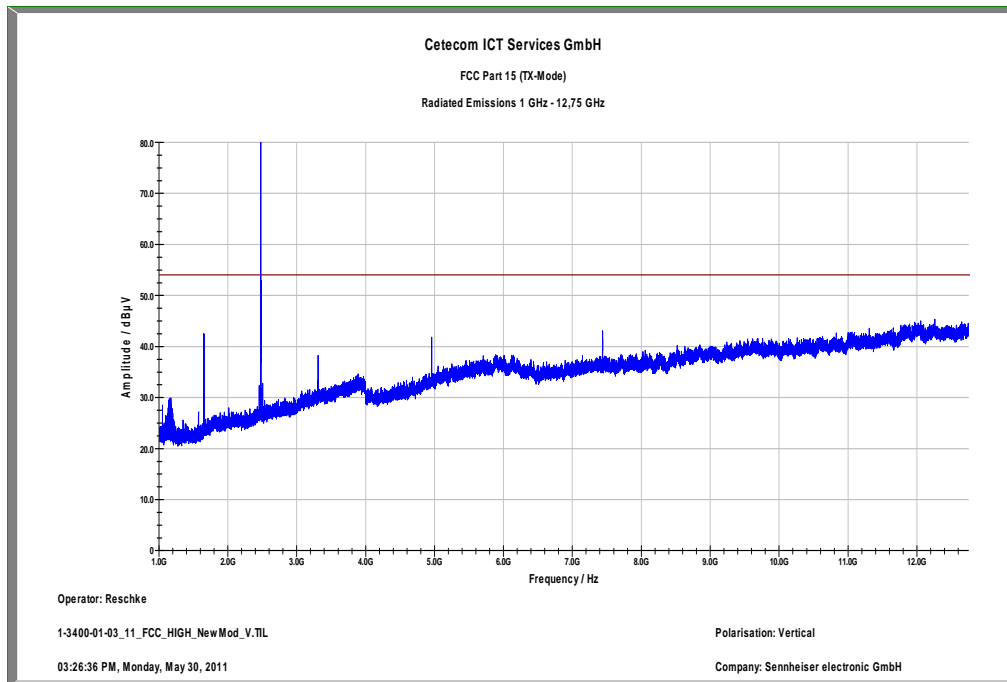

9.12 RX spurious emissions radiated

Description:

Measurement of the radiated spurious emissions in idle/receive mode. The EUT is detached so all oscillators are active.

Measurement:

Measurement parameter	
Detector:	Peak / Quasi peak
Sweep time:	Auto
Video bandwidth:	Sweep: 100 kHz Remeasurement: 10 Hz
Resolution bandwidth:	F < 1 GHz: 100 kHz F > 1 GHz: 1 MHz
Span:	30 MHz to 25 GHz
Trace-Mode:	Max Hold

Limits:

FCC		IC
CFR Part 15.109		RSS Gen, Issue 2, 4.10
RX Spurious Emissions Radiated		
Frequency (MHz)	Field strength (dB μ V/m)	Measurement distance
30 - 88	30.0	10
88 – 216	33.5	10
216 – 960	36.0	10
Above 960	54.0	3

Result: Also see plots

RX spurious emissions radiated [dB μ V/m]		
F [MHz]	Detector	Level [dB μ V/m]
No critical peaks found		
Measurement uncertainty	±3 dB	

Result: The result of the measurement is passed.

Plot 1: 30 MHz to 1 GHz / idle-mode (horizontal/vertical)

Common Information

EUT: S1 digital
 Serial Number: prototype
 Test Description: FCC Part 15 C < 1 GHz @ 10m
 Operating Conditions: BT RX
 Operator Name: Langer
 Comment: DC 3V

Scan Setup: STAN_Fin [EMI radiated]

Hardware Setup: Electric Field (NOS)
 Level Unit: dBµV/m

Subrange	Detectors	IF Bandwidth	Meas. Time	Receiver
30 MHz - 2 GHz	QuasiPeak	120 kHz	15 s	Receiver

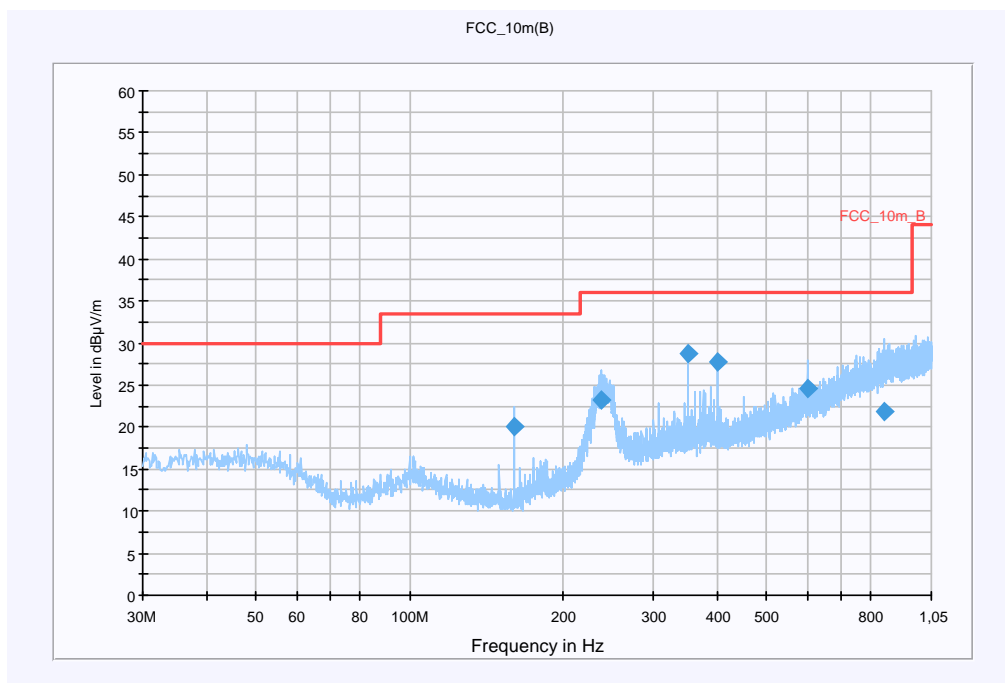

Final Result 1

Frequency (MHz)	QuasiPeak (dBµV/m)	Meas. Time (ms)	Bandwidth (kHz)	Antenna height (cm)	Polarity	Turntable position (deg)	Corr. (dB)	Margin (dB)	Limit (dBµV/m)	Comment
159.973500	20.1	15000.000	120.000	200.0	V	93.0	9.2	13.4	33.5	
236.365950	23.2	15000.000	120.000	98.0	V	213.0	12.9	12.8	36.0	
349.992000	28.8	15000.000	120.000	246.0	H	275.0	16.1	7.2	36.0	
399.996600	27.8	15000.000	120.000	258.0	H	82.0	16.9	8.2	36.0	
600.004500	24.6	15000.000	120.000	98.0	H	235.0	20.8	11.4	36.0	
851.290350	21.9	15000.000	120.000	400.0	V	199.0	24.6	14.1	36.0	

Plot 2: 1 GHz to 12.75 GHz / idle-mode (horizontal/vertical)

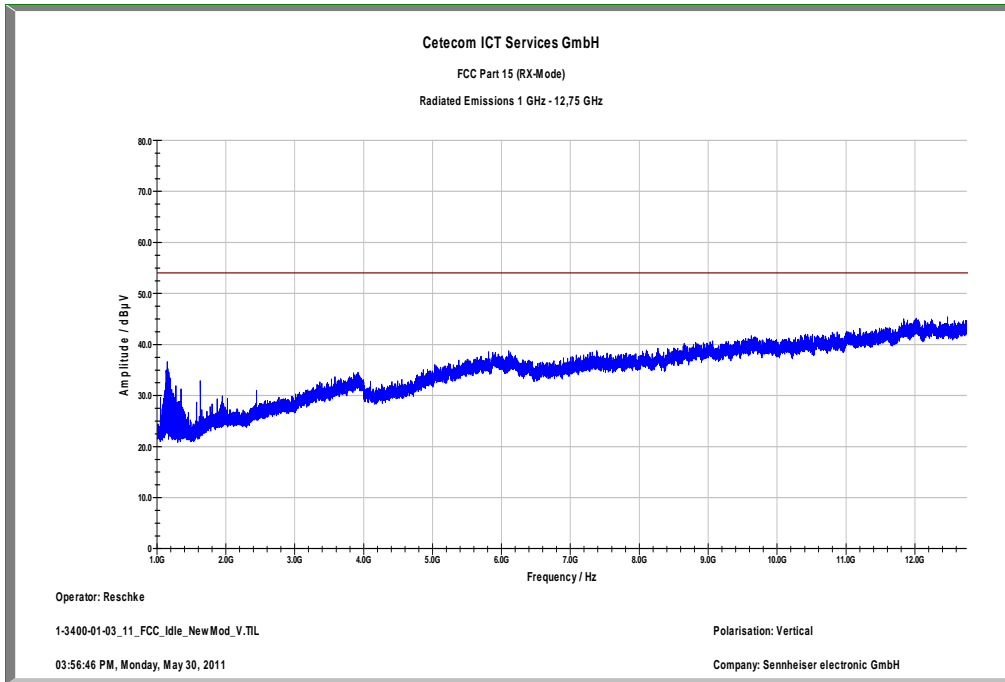

Plot 3: 12 GHz to 25 GHz / idle-mode (horizontal/vertical)

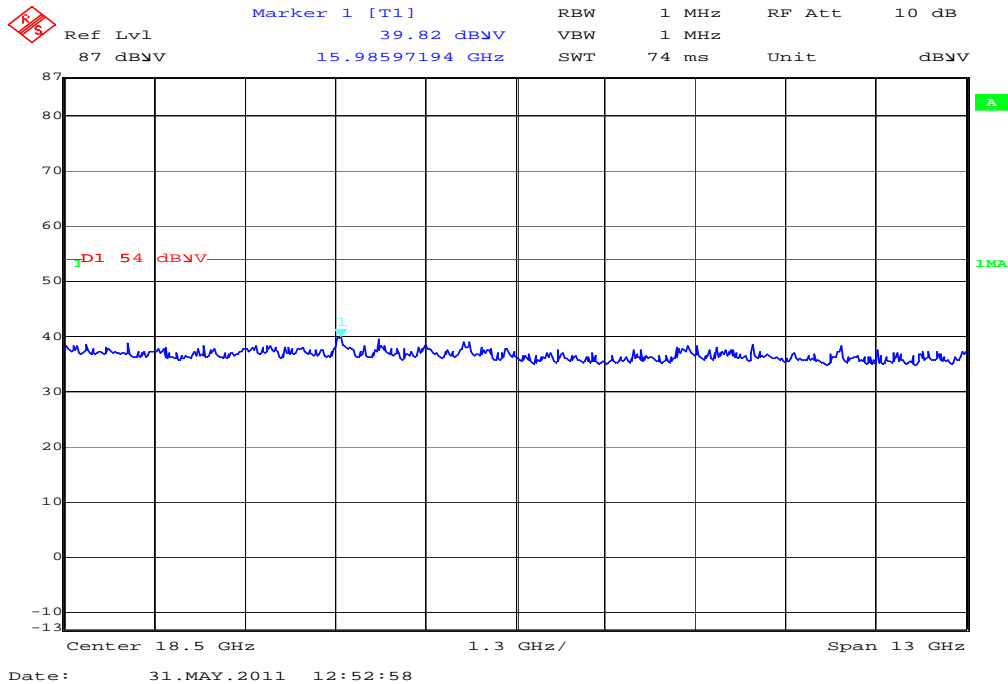

9.13 TX spurious emissions radiated < 30 MHz

Description:

Measurement of the radiated spurious emissions in transmit mode below 30 MHz. The EUT is set to single channel mode and the transmit channel is channel 39. This measurement is representative for all channels and modes. If critical peaks are found channel 00 and channel 78 will be measured too. The measurement is performed in the mode with the highest output power. The limits are recalculated to a measurement distance of 3 m with 40 dB/decade according CFR Part 2.

Measurement:

Measurement parameter	
Detector:	Peak / Quasi peak
Sweep time:	Auto
Video bandwidth:	F < 150 kHz: 200 Hz F > 150 kHz: 9 kHz
Resolution bandwidth:	F < 150 kHz: 1 kHz F > 150 kHz: 100 kHz
Span:	9 kHz to 30 MHz
Trace-Mode:	Max Hold

Limits:

FCC		IC	
CFR Part 15.209(a)		RSS 210, Issue 7, 2.2	
TX spurious emissions radiated < 30 MHz			
Frequency (MHz)	Field strength (dBµV/m)	Measurement distance	
0.009 – 0.490	2400/F(kHz)	300	
0.490 – 1.705	24000/F(kHz)	30	
1.705 – 30.0	30	30	

Result: Also see plot

TX spurious emissions radiated < 30 MHz [dBµV/m]		
F [MHz]	Detector	Level [dBµV/m]
No critical peaks found		
Measurement uncertainty	± 3 dB	

Result: The result of the measurement is passed.

Plot 1: 9 kHz to 30 MHz / channel 39 (valid for all channels and modes)

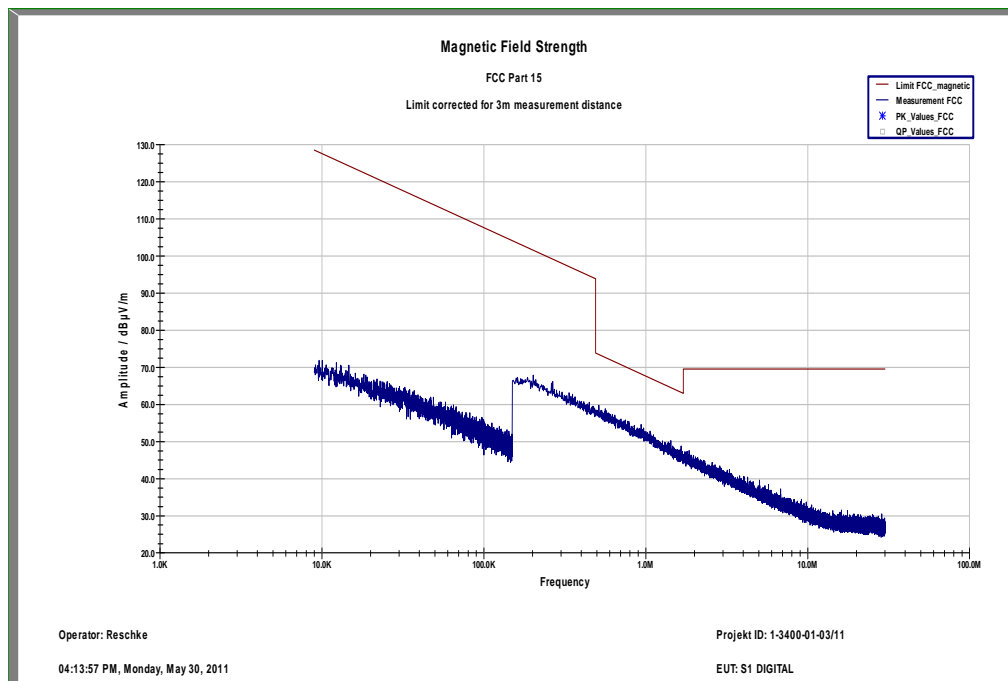

9.14 TX spurious emissions conducted < 30 MHz

Description:

Measurement of the conducted spurious emissions in transmit mode below 30 MHz. The EUT is set to single channel mode and the transmit channel is channel 39. This measurement is representative for all channels and modes. If critical peaks are found channel 00 and channel 78 will be measured too. The measurement is performed in the mode with the highest output power. Both power lines, phase and neutral line, are measured. Found peaks are remeasured with average and quasi peak detection to show compliance to the limits.

Measurement:

Measurement parameter	
Detector:	Peak - Quasi peak / average
Sweep time:	Auto
Video bandwidth:	F < 150 kHz: 200 Hz F > 150 kHz: 9 kHz
Resolution bandwidth:	F < 150 kHz: 1 kHz F > 150 kHz: 100 kHz
Span:	9 kHz to 30 MHz
Trace-Mode:	Max Hold

No charger available.

A power supply was used for this measurement.

Limits:

FCC		IC	
CFR Part 15.107(a)		ICES-003, Issue 4	
TX spurious emissions conducted < 30 MHz			
Frequency (MHz)	Quasi-peak (dBµV/m)	Average (dBµV/m)	
0.15 – 0.5	66 to 56*	56 to 46*	
0.5 – 5	56	46	
5 – 30.0	60	50	

*Decreases with the logarithm of the frequency

Result: Also see plots

TX spurious emissions conducted < 30 MHz [dBμV/m]		
F [MHz]	Detector	Level [dBμV/m]
No critical peaks found		
Measurement uncertainty	± 3 dB	

Result: The result of the measurement is passed.

Plot 1: 9 kHz to 30 MHz / phase Line

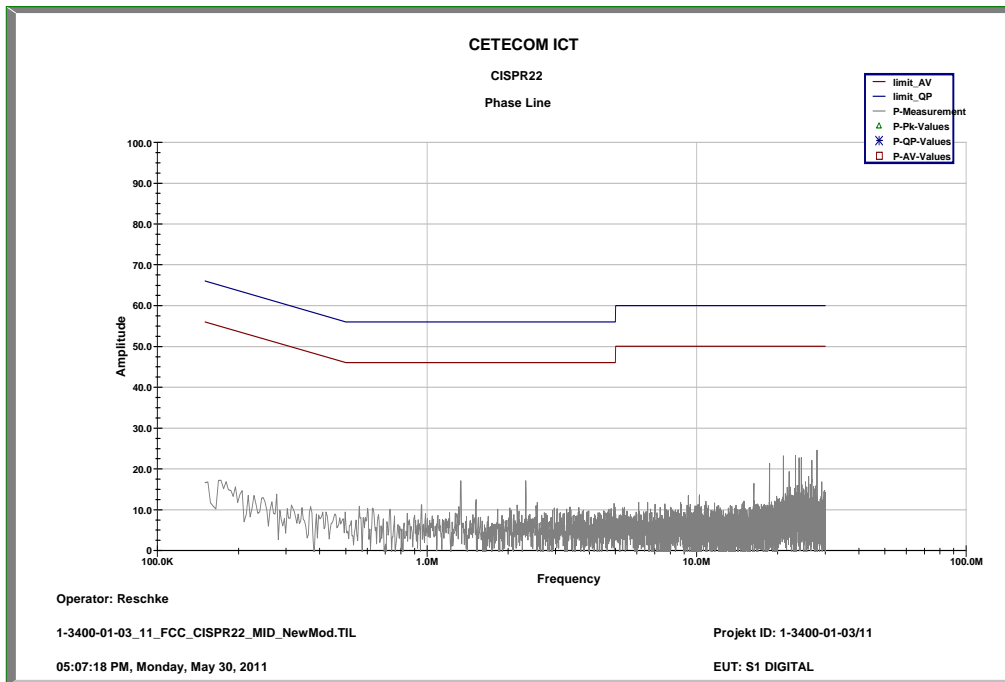

Plot 2: 9 kHz to 30 MHz / neutral Line

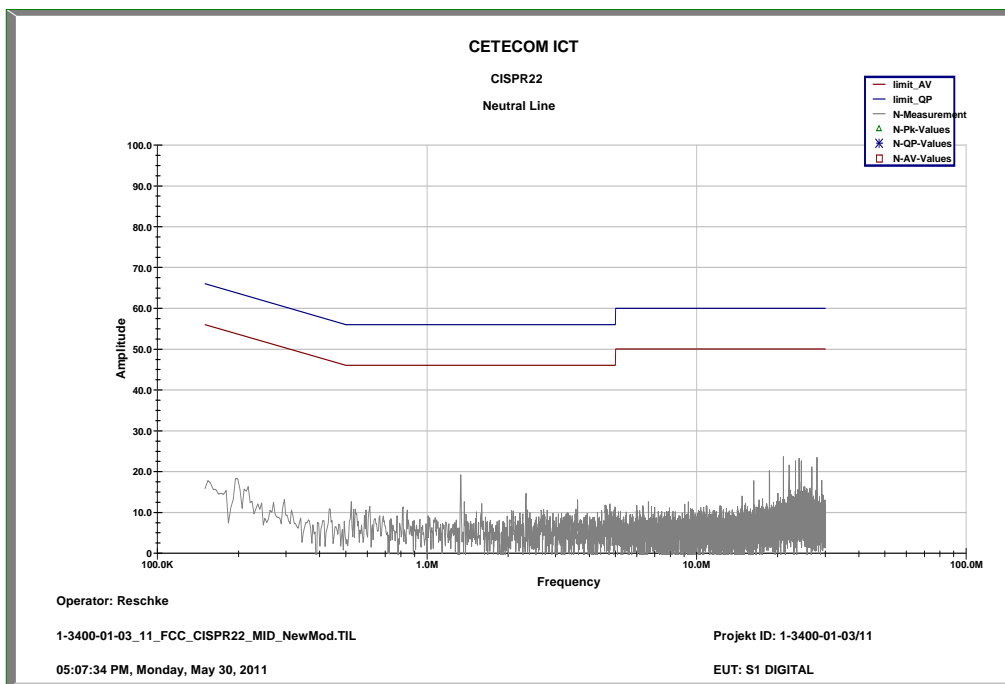

10 Test equipment and ancillaries used for tests

Typically, the calibrations of the test apparatus are commissioned to and performed by an accredited calibration laboratory. The calibration intervals are determined in accordance with the DIN EN ISO/IEC 17025. In addition to the external calibrations, the laboratory executes comparison measurements with other calibrated test systems or effective verifications. Weekly chamber inspections and range calibrations are performed. Where possible, rf-generating and signalling equipment as well as measuring receivers and analyzers are connected to an external high-precision 10 MHz reference (GPS-based or rubidium frequency standard).

In order to simplify the identification of the equipment used at some special tests, some items of test equipment and ancillaries can be provided with an identifier or number in the equipment list below (Labor/Item).

No.	Lab / Item	Equipment	Type	Manufact.	Serial No.	INV. No Cetecom	Kind of Calibration	Last Calibration	Next Calibration
1	45	Switch-Unit	3488A	HP Meßtechnik	2719A14505	300000368	g		
2	50	DC power supply, 60Vdc, 50A, 1200 W	6032A	HP Meßtechnik	2920A04466	300000580	k		
3	n. a.	software	SPS_PHE 1.4f	Spitzberger & Spieß	B5981; 5D1081;B5979	300000210	ne		
4	n. a.	EMI Test Receiver	ESCI 1166.5950.03	R&S	100083	300003312	k	05.01.2011	05.01.2013
5	n. a.	Analyzer-Reference-System (Harmonics and Flicker)	ARS 16/1	SPS	A3509 07/0 0205	300003314	k		
6	n. a.	Amplifier	JS42-00502650-28-5A	MITEQ	1084532	300003379	ev		
7	n. a.	Antenna Tower	Model 2175	ETS-LINDGREN	64762	300003745	izw		
8	n. a.	Positioning Controller	Model 2090	ETS-LINDGREN	64672	300003746	izw		
9	n. a.	Turntable Interface-Box	Model 105637	ETS-LINDGREN	44583	300003747	izw		
10	n. a.	TRILOG Broadband Test-Antenna 30 MHz - 3 GHz	VULB9163	Schwarzbeck	295	300003787	k	01.04.2010	01.04.2012
11	n. a.	Spectrum-Analyzer	FSU26	R&S	200809	300003874	k	10.01.2011	10.01.2013
12	n. a.	Isolating Transformer	RT5A	Grundig	8041	300001626	g		
13	n. a.	DC power supply, 60Vdc, 50A, 1200 W	6032A	HP Meßtechnik	2818A03450	300001040	Ve	08.01.2009	08.01.2012
14	n. a.	Coaxial Attenuator 30dB/500W	8325	Bird	1530	300001595	ev		
15	n. a.	Double-Ridged Waveguide Horn Antenna 1-18.0GHz	3115	EMCO	8812-3088	300001032	viKI!	05.03.2009	05.09.2011
16	n. a.	Active Loop Antenna	6502	EMCO	2210	300001015	ne		
17	n. a.	Anechoic chamber	FAC 3/5m	MWB / TDK	87400/02	300000996		23.03.2009	
18	Spec.A. 2_2e	System rack for EMI measurement solution	85900	HP I.V.	*	300000222	ne		
19	9	Artificial Mains 9 kHz to 30 MHz	ESH3-Z5	R&S	828576/020	300001210	Ve	06.01.2010	06.01.2012
20	n. a.	Relais Matrix	3488A	HP Meßtechnik	2719A15013	300001156	ne		
21	n. a.	Relais Matrix	PSU	R&S	890167/024	300001168	ne		
22	n. a.	Isolating Transformer	RT5A	Grundig	9242	300001263	ne		
23	n. a.	Three-Way	11850C	HP		300000997	ne		

		Power Splitter, 50 Ohm		Meßtechnik						
24	n. a.	Switch / Control Unit	3488A	HP	2605e08770	300001443	ne			
25	n. a.	Amplifier	js42-00502650-28-5a	Parzich GMBH	928979	300003143	ne			
26	n. a.	Band Reject filter	WRCG1855/1910-1835/1925-40/8SS	Wainwright	7	300003350	ev			
27	n. a.	Band Reject filter	WRCG2400/2483-2375/2505-50/10SS	Wainwright	11	300003351	ev			
28	n. a.	TILE-Software Emission	Quantum Change, Modell TILE-ICS/FULL	EMCO	none	300003451	ne			
29	n. a.	Highpass Filter	WHKX2.9/18G-12SS	Wainwright	1	300003492	ev			
30	n. a.	Highpass Filter	WHK1.1/15G-10SS	Wainwright	3	300003255	ev			
31	n. a.	Highpass Filter	WHKX7.0/18G-8SS	Wainwright	18	300003789	ne			
32	n. a.	PSA Spectrum Analyzer 3 Hz - 26.5 GHz	E4440A	Agilent Technologies	MY48250080	300003812	k	08.09.2010	08.09.2012	
33	n. a.	MXG Microwave Analog Signal Generator	N5183A	Agilent Technologies	MY47420220	300003813	k	13.09.2010	13.09.2012	
34	n. a.	RF Filter Section 9kHz - 1GHz	N9039A	Agilent Technologies	MY48260003	300003825	viKI!	08.09.2010	08.09.2012	
35	n. a.	TRILOG Broadband Test-Antenna 30 MHz - 3 GHz	VULB9163	Schwarzbeck	371	300003854	viKI!	17.12.2008	17.12.2011	
36	19	Double-Ridged Waveguide Horn Antenna 1-18.0GHz	3115	EMCO	9107-3697	300001605	Ve	19.10.2010	19.10.2012	
37	n. a.	Signal Analyzer 20Hz-26.5GHz-150 to + 30 DBM	FSIQ26	R&S	835111/0004	300002678	Ve	04.11.2010	04.11.2012	
38	n. a.	Switch / Control Unit	3488A	HP Meßtechnik		300001691	ne			
39	n. a.	Power Supply DC	NGPE 40/40	R&S	388	400000078	viKI!	13.09.2010	13.09.2012	
40	n. a.	Power Sensor 50 Ohms, 10 MHz - 18 GHz, 1 nW - 20 mW	NRV-Z1	R&S	833894/011	300002681-0010	k	09.09.2010	09.09.2012	
41	n. a.	Hygro-Thermometer	-/, 5-45°C, 20-100%rF	Thies Clima	-/	400000080	k	04.05.2010	04.11.2011	
42	n. a.	Vector Signal Generator, 300 kHz to 2.2 GHz	SMIQ03B	R&S	835541/055	300002681-0001	k			
43	n. a.	Vector Signal Generator, 300 kHz to 2.2 GHz	SMIQ03B	R&S	835541/056	300002681-0002	k	26.08.2008	26.08.2011	
44	n. a.	Signal Generator 0.01/2 - 20 GHz, Freq. Resol. 0.1Hz	SMP02	R&S	835133/011	300002681-0003	k	26.08.2008	26.08.2011	
45	n. a.	Dual Channel Power Meter	NRVD	R&S	835430/044	300002681-0004	k	13.09.2010	13.09.2012	
46	n. a.	Signal Analyzer 20Hz-26.5GHz-150 to + 30 DBM	FSIQ26	R&S	835540/018	300002681-0005	k	07.01.2010	07.01.2012	
47	n. a.	Frequency Standard (Rubidium Frequency Standard)	MFS (Rubidium)	R&S (Datum)	002	300002681-0009	Ve	13.09.2010	13.09.2012	

48	n. a.	Directional Coupler	101020010	Krytar	70215	300002840	ev		
49	n. a.	DC-Blocker	8143	Inmet Corp.	none	300002842	ne		
50	n. a.	Powersplitter	6005-3	Inmet Corp.		300002841	ev		
51	n. a.	Temperature Test Chamber	VT 4002	Heraeus Voetsch	58566046820010	300003019	Ve		
52	n. a.	CBT (Bluetooth Tester + EDR Signalling)	CBT 1153.9000K35	R&S	100185	300003416	vkI!	13.09.2010	13.09.2012
53	n. a.	Spectrum Analyzer 9kHz to 30GHz - 140..+30dBm	FSP30	R&S	100886	300003575	k	07.09.2010	07.09.2012
54	n. a.	CBT-K57 Software-Option for CBT/CBT32	CBT-K57	R&S	101051	300003910	ne		

Agenda: Kind of Calibration

k	calibration / calibrated	EK	limited calibration
ne	not required (k, ev, izw, zw not required)	zw	cyclical maintenance (external cyclical maintenance)
ev	periodic self verification	izw	internal cyclical maintenance
Ve	long-term stability recognized	g	blocked for accredited testing
vkI!	Attention: extended calibration interval	*)	next calibration ordered / currently in progress
NK!	Attention: not calibrated		

Annex A Photographs of the test setup

Photo documentation

Photo 1:

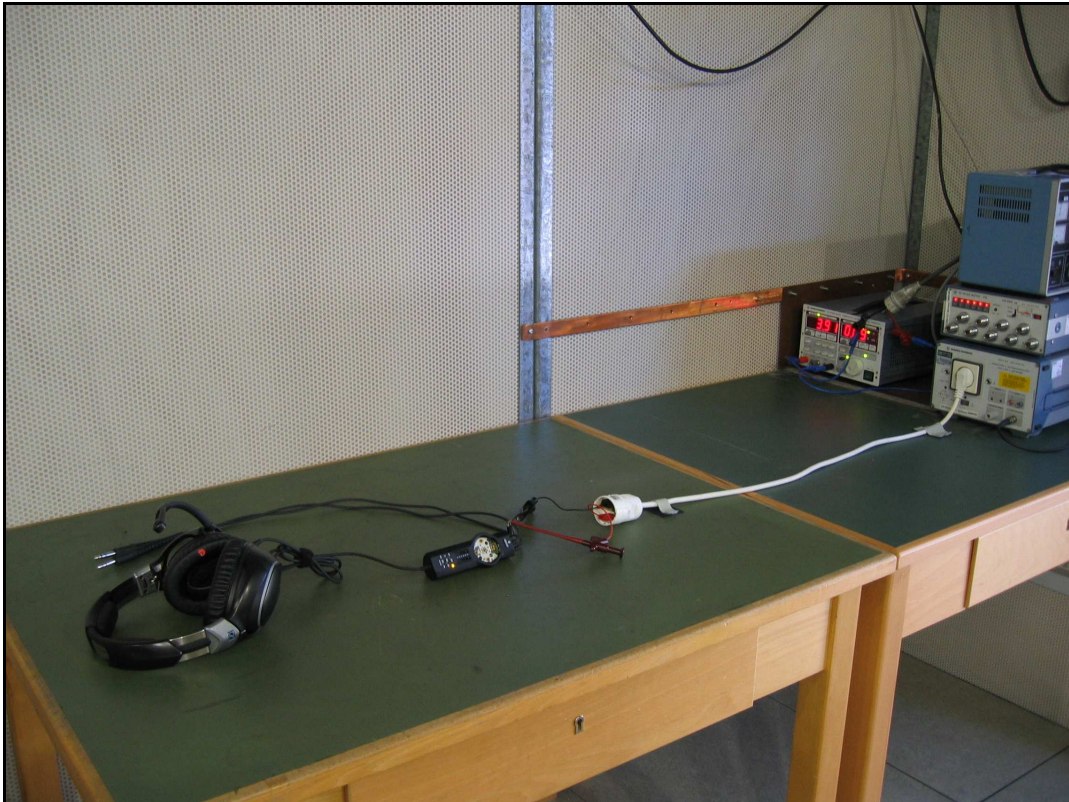

Annex B External photographs of the EUT

Photo documentation

Photo 2:



Photo 3:



Photo 4:

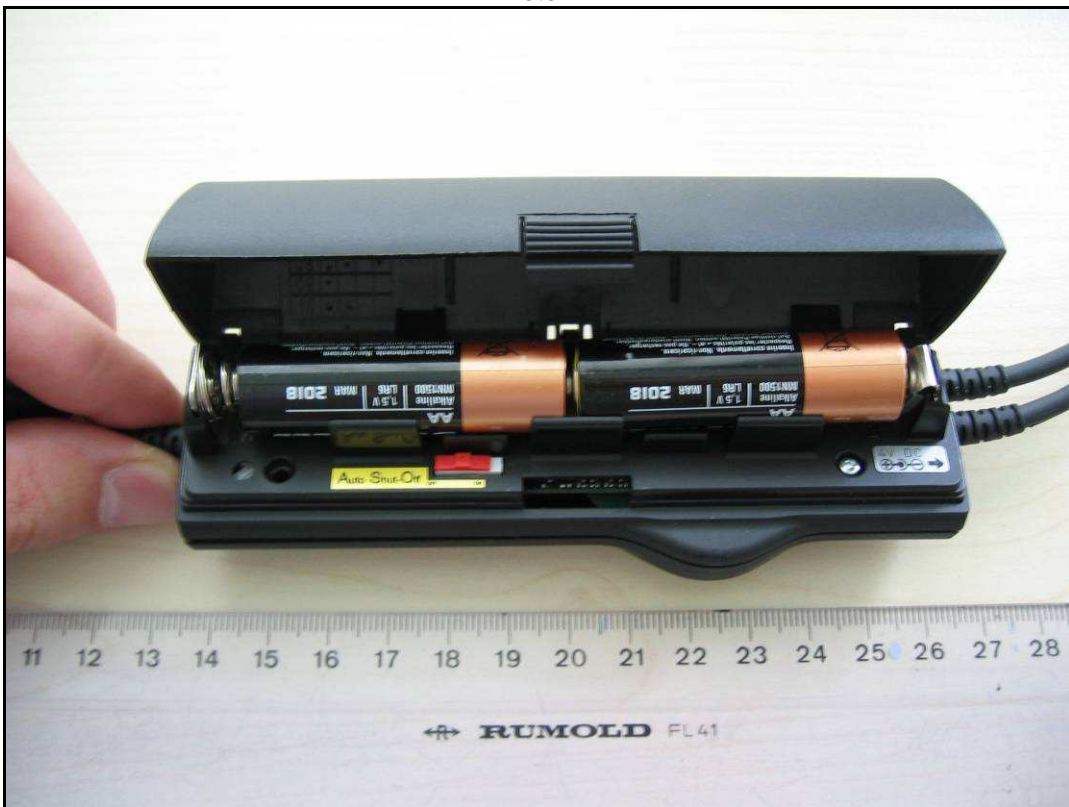

Photo 5:



Photo 6:



Annex C Internal photographs of the EUT

Photo documentation

Photo 7:

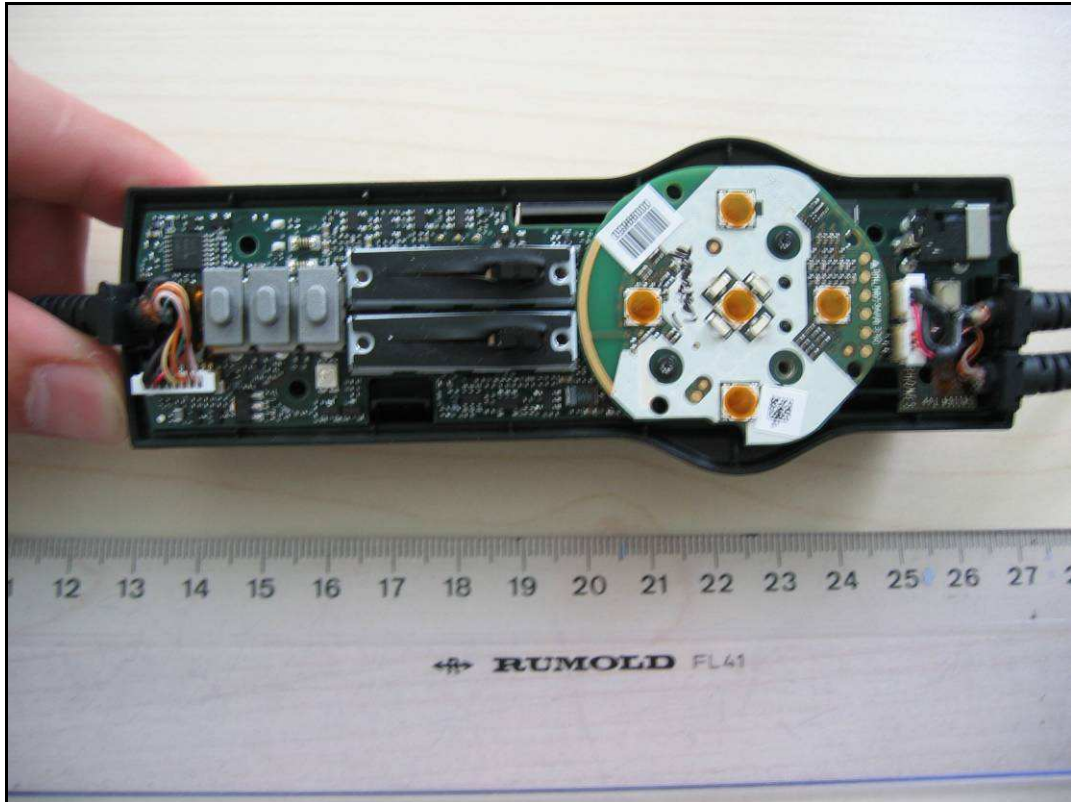

Photo 8:

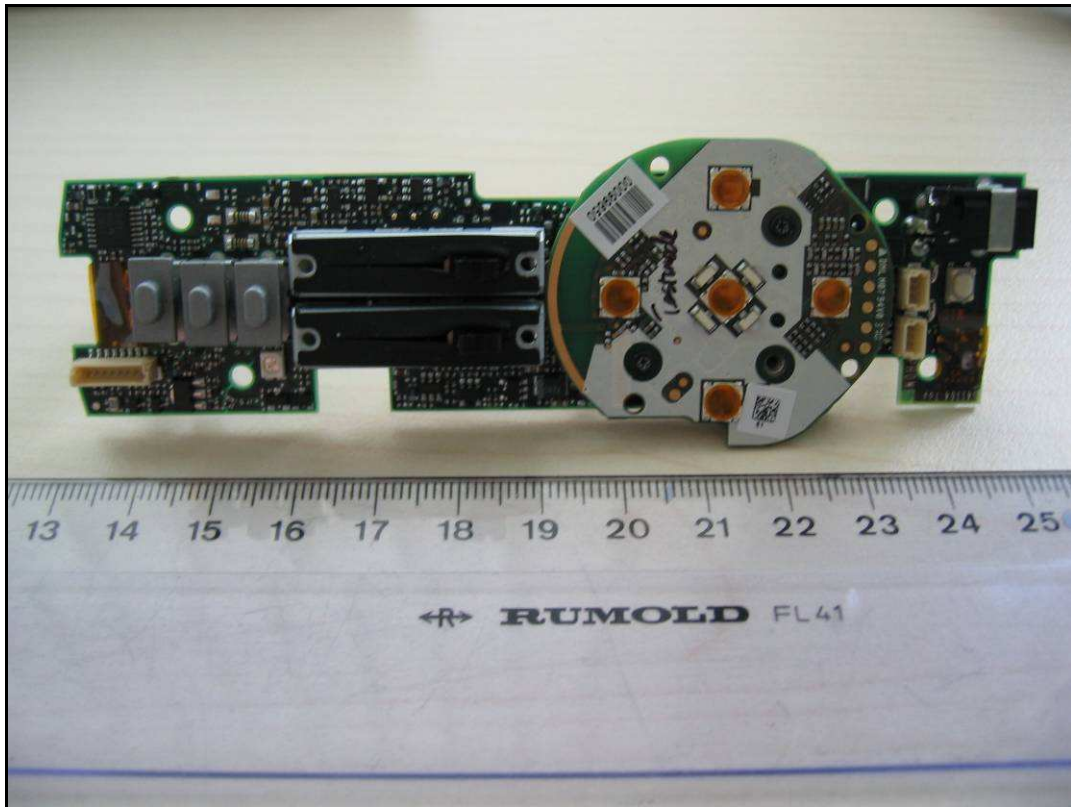

Photo 9:

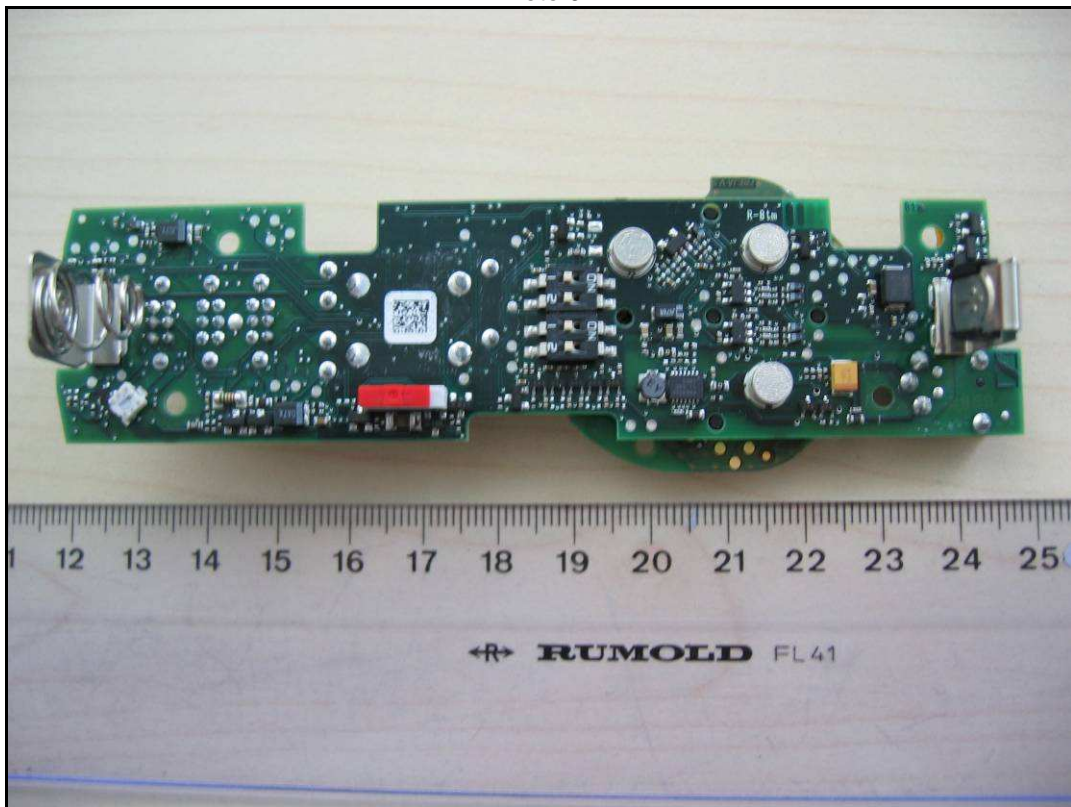

Photo 10:

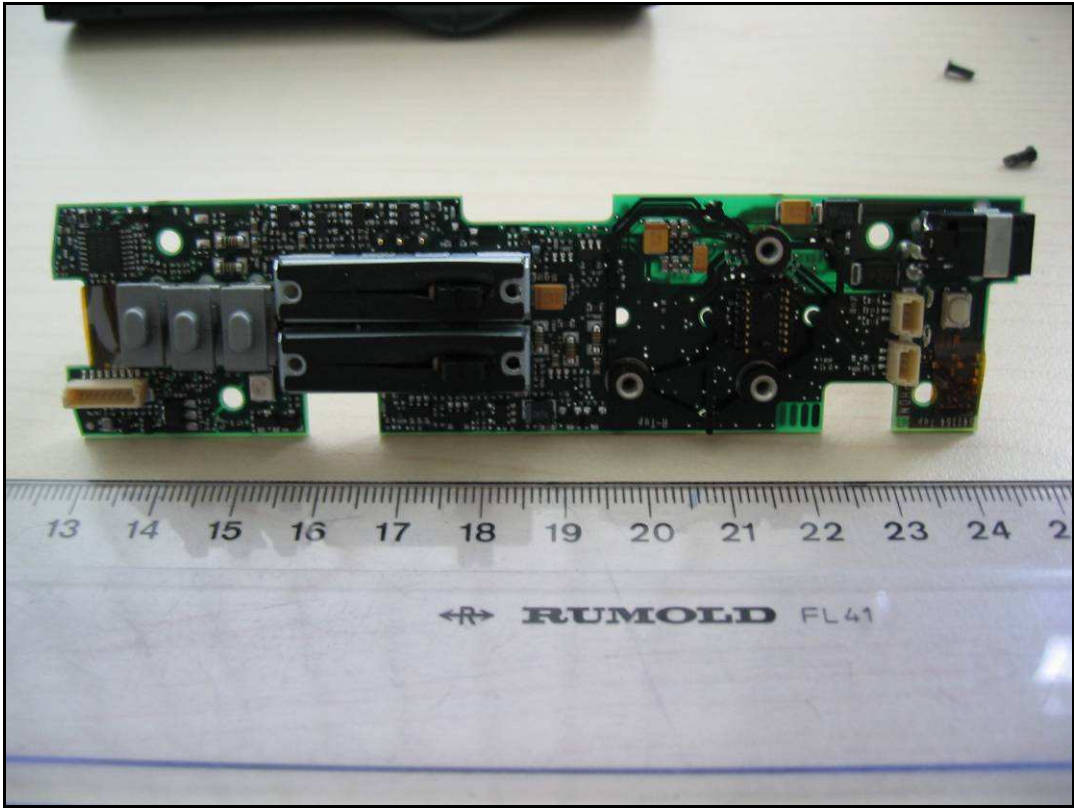

Photo 11:

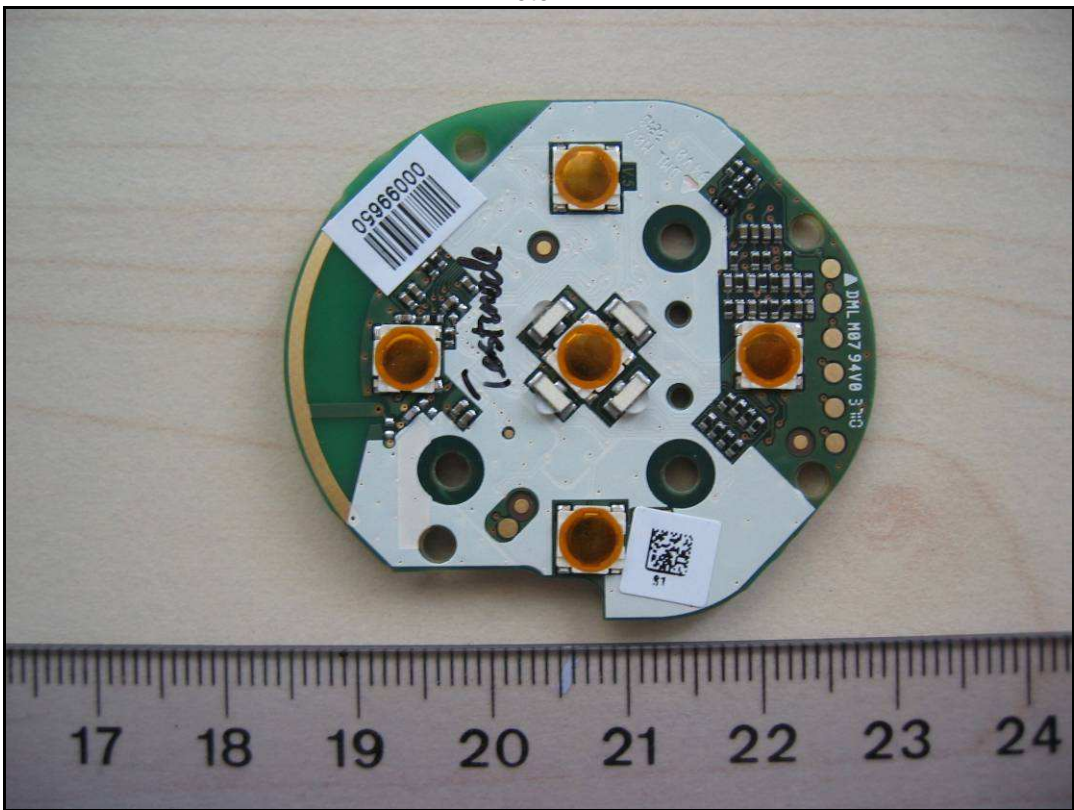

Photo 12:

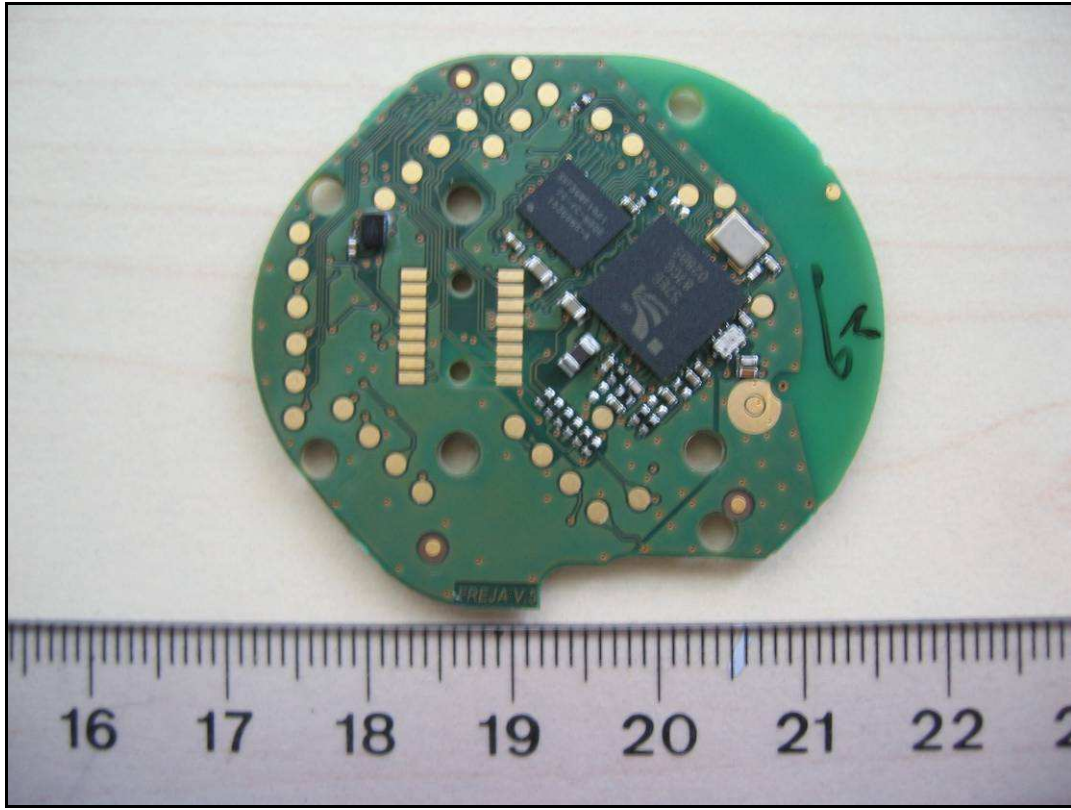

Photo 13:



Photo 14:



Photo 15:

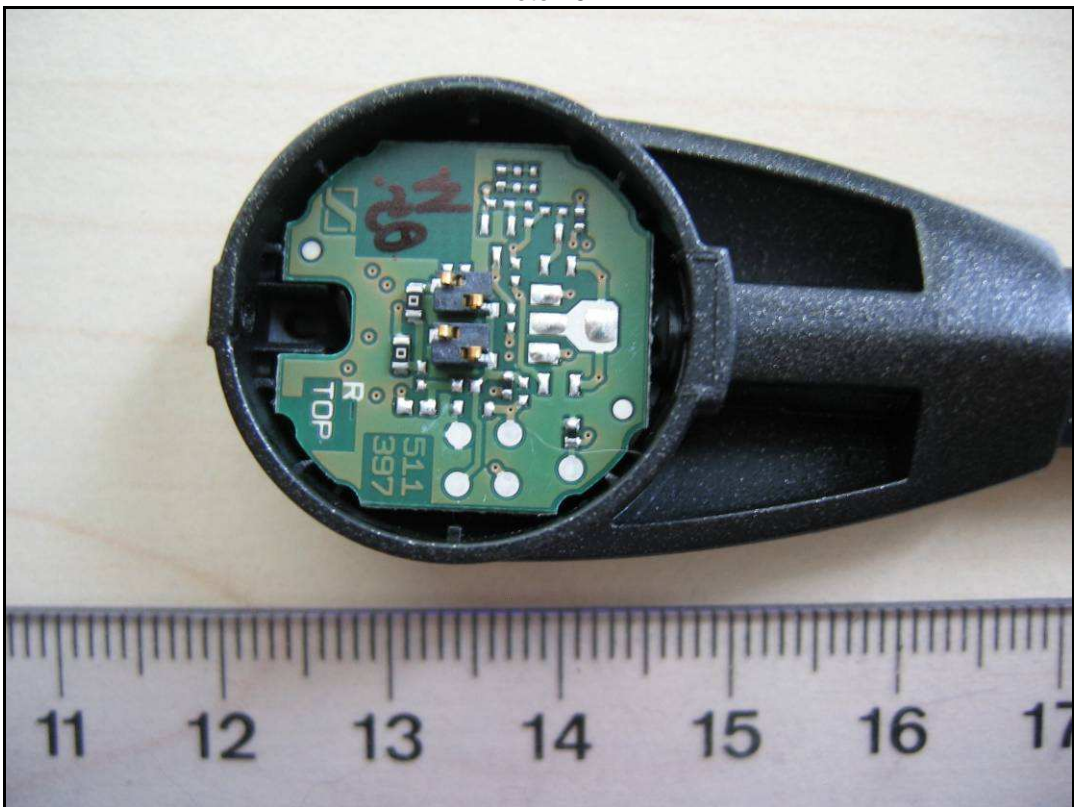

Photo 16:



Photo 17:

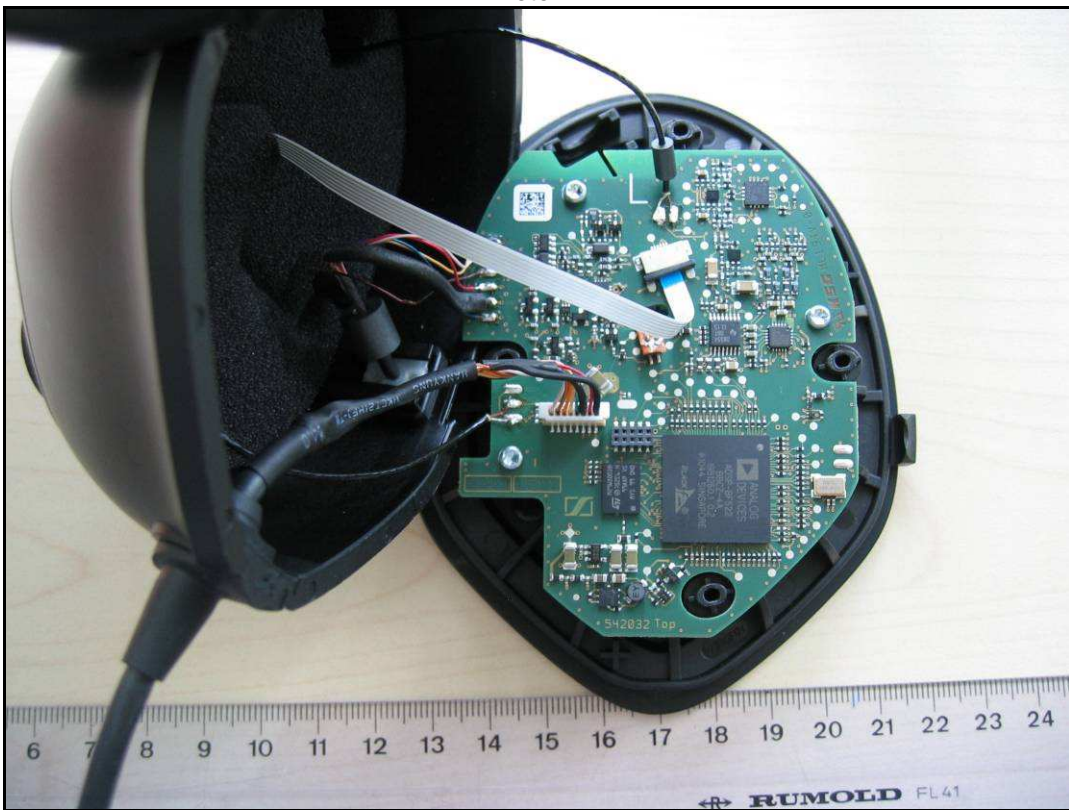

Photo 18:

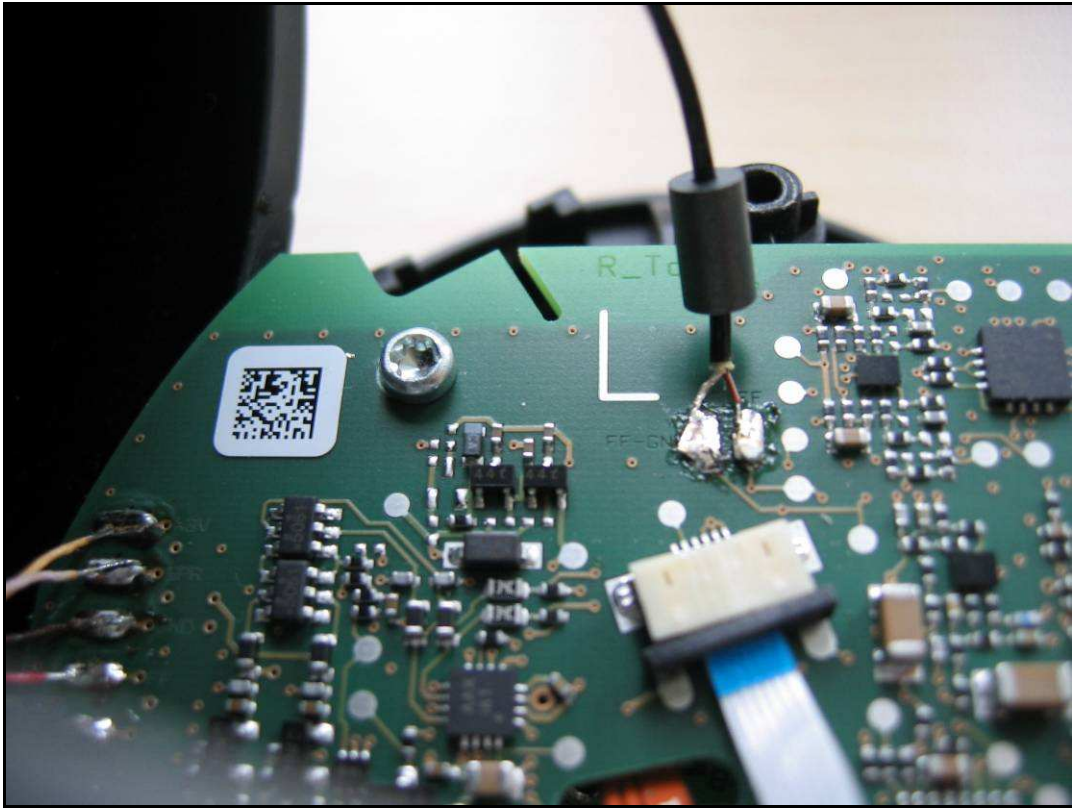

Photo 19:

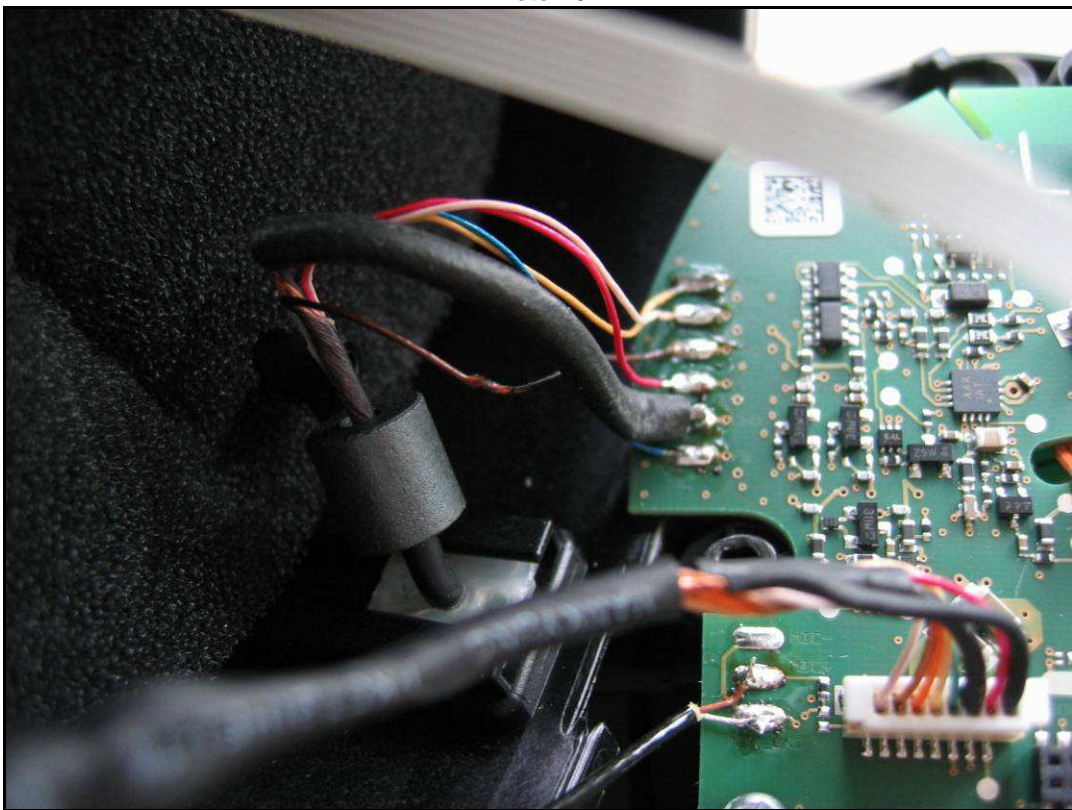

Photo 20:

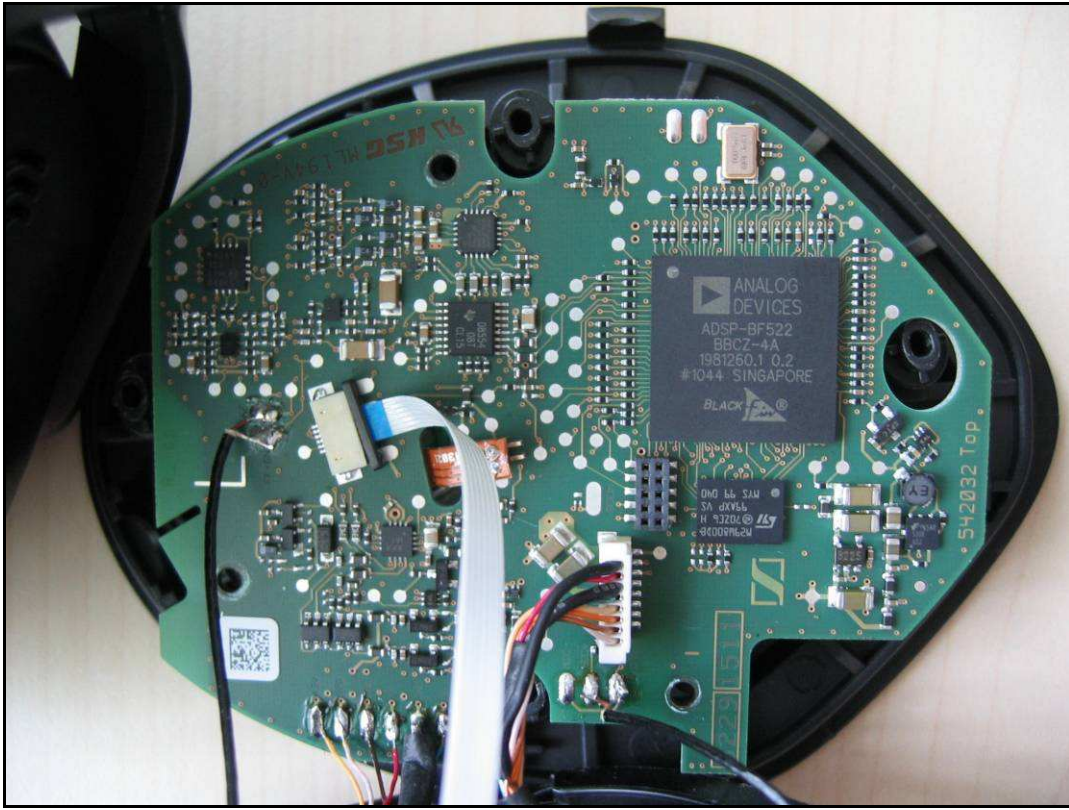

Photo 21:

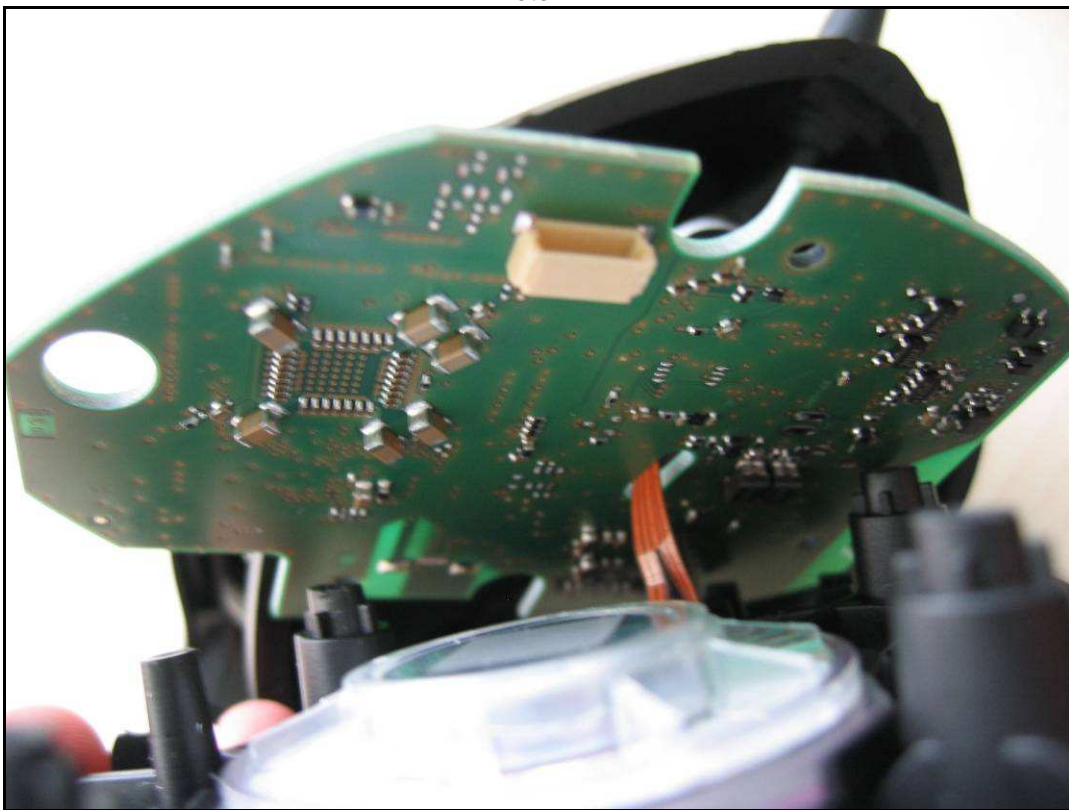

Photo 22:



Annex D Document history

Version	Applied changes	Date of release
1.0	Initial release	2011-06-07
-A	Picture with label location added	

Annex E Further information**Glossary**

DUT	-	Device under Test
EMC	-	Electromagnetic Compatibility
EUT	-	Equipment under Test
FCC	-	Federal Communication Commission
FCC ID	-	Company Identifier at FCC
HW	-	Hardware
IC	-	Industry Canada
Inv. No.	-	Inventory number
N/A	-	not applicable
S/N	-	Serial Number
SW	-	Software