



TEST REPORT

Test report no.: 1-4298/17-02-09



BNetzA-CAB-02/21-102

Testing laboratory

CTC advanced GmbH

Untertuerkheimer Strasse 6 – 10
66117 Saarbruecken / Germany
Phone: + 49 681 5 98 - 0
Fax: + 49 681 5 98 - 9075
Internet: <http://www.ctcadvanced.com>
e-mail: mail@ctcadvanced.com

Accredited Testing Laboratory:

The testing laboratory (area of testing) is accredited according to DIN EN ISO/IEC 17025 (2005) by the Deutsche Akkreditierungsstelle GmbH (DAkkS). The accreditation is valid for the scope of testing procedures as stated in the accreditation certificate with the registration number: D-PL-12076-01-03

Applicant

Sennheiser electronic GmbH & Co. KG

Am Labor 1
30900 Wedemark / GERMANY
Phone: +49 5130 600-0
Fax: +49 5130 600-574
Contact: Volker Bartsch
e-mail: volker.bartsch@sennheiser.com
Phone: +49 5130 600 1465

Manufacturer

Sennheiser electronic GmbH & Co. KG

Am Labor 1
30900 Wedemark / GERMANY

Test standard/s

47 CFR Part 74 Title 47 of the Code of Federal Regulations; Chapter I; Part 74 - Experimental radio, auxiliary, special broadcast and other program distributional services
RSS - 210 Issue 9 Spectrum Management and Telecommunications Radio Standards Specification - Licence-Exempt Radio Apparatus: Category I Equipment
For further applied test standards please refer to section 3 of this test report.

Test Item

Kind of test item: UHF Wireless Microphones – Bodypack Transmitter
Model name: SK 300 G4, SK 500 G4, SK 100 G4
FCC ID: DMOG4SK
IC: 2099A-G4SK
Frequency: 470 MHz to 608 MHz
Technology tested: Proprietary
Antenna: Integrated antenna
Power supply: 2.55 V to 3.45 V DC by 2 x AA batteries
Temperature range: -30°C to +50°C



This test report is electronically signed and valid without handwritten signature. For verification of the electronic signatures, the public keys can be requested at the testing laboratory.

Test report authorized:

Andreas Luckenbill
Lab Manager
Radio Communications & EMC

Test performed:

Yves Olsommer
Testing Manager
Radio Communications & EMC

1 Table of contents

1	Table of contents	2
2	General information	3
2.1	Notes and disclaimer	3
2.2	Application details.....	3
2.3	Test laboratories sub-contracted	3
3	Test standard/s and references	4
4	Test environment.....	5
5	Test item.....	5
5.1	General description	5
5.2	Additional information	5
6	Description of the test setup.....	6
6.1	Shielded fully anechoic chamber	7
6.2	RF measurements normal and extreme conditions.....	8
7	Sequence of testing	9
7.1	Sequence of testing radiated spurious 9 kHz to 30 MHz.....	9
7.2	Sequence of testing radiated spurious 30 MHz to 1 GHz.....	10
7.3	Sequence of testing radiated spurious 1 GHz to 12.75 GHz	11
8	Measurement uncertainty	12
9	Summary of measurement results	13
10	Additional comments	14
11	Measurement results	15
11.1	Transmitter output power	15
11.2	Occupied bandwidth.....	16
11.3	Transmitter frequency stability	22
11.4	Transmitter unwanted emissions (radiated)	27
11.5	Modulation characteristics	37
11.6	Necessary bandwidth (BN) for analogue systems	41
11.7	Frequency modulation	48
12	Observations	54
Annex A	Glossary.....	55
Annex B	Document history	56
Annex C	Accreditation Certificate	56

2 General information

2.1 Notes and disclaimer

The test results of this test report relate exclusively to the test item specified in this test report. CTC advanced GmbH does not assume responsibility for any conclusions and generalizations drawn from the test results with regard to other specimens or samples of the type of the equipment represented by the test item.

The test report may only be reproduced or published in full. Reproduction or publication of extracts from the report requires the prior written approval of CTC advanced GmbH.

The testing service provided by CTC advanced GmbH has been rendered under the current "General Terms and Conditions for CTC advanced GmbH".

CTC advanced GmbH will not be liable for any loss or damage resulting from false, inaccurate, inappropriate or incomplete product information provided by the customer.

Under no circumstances does the CTC advanced GmbH test report include any endorsement or warranty regarding the functionality, quality or performance of any other product or service provided.

Under no circumstances does the CTC advanced GmbH test report include or imply any product or service warranties from CTC advanced GmbH, including, without limitation, any implied warranties of merchantability, fitness for purpose, or non-infringement, all of which are expressly disclaimed by CTC advanced GmbH.

All rights and remedies regarding vendor's products and services for which CTC advanced GmbH has prepared this test report shall be provided by the party offering such products or services and not by CTC advanced GmbH. In no case this test report can be considered as a Letter of Approval.

This test report is electronically signed and valid without handwritten signature. For verification of the electronic signatures, the public keys can be requested at the testing laboratory.

2.2 Application details

Date of receipt of order:	2017-11-17
Date of receipt of test item:	2017-11-14
Start of test:	2017-12-13
End of test:	2018-02-05
Person(s) present during the test:	-/-

2.3 Test laboratories sub-contracted

None

3 Test standard/s and references

Test standard	Date	Description
47 CFR Part 74		Title 47 of the Code of Federal Regulations; Chapter I; Part 74 - Experimental radio, auxiliary, special broadcast and other program distributional services
RSS - 210 Issue 9	August 2016	Spectrum Management and Telecommunications Radio Standards Specification - Licence-Exempt Radio Apparatus: Category I Equipment

Guidance	Version	Description
ANSI C63.4-2014	-/-	American national standard for methods of measurement of radio-noise emissions from low-voltage electrical and electronic equipment in the range of 9 kHz to 40 GHz
ANSI C63.10-2013	-/-	American national standard of procedures for compliance testing of unlicensed wireless devices

4 Test environment

Temperature	: T _{nom} T _{max} T _{min}	+21 °C during room temperature tests +50 °C during high temperature tests -30 °C during low temperature tests
Relative humidity content	:	43 %
Barometric pressure	:	1009 hpa
Power supply	: V _{nom} V _{max} V _{min}	3.00 V DC by 2 x AA batteries 3.45 V 2.55 V

5 Test item

5.1 General description

Kind of test item	:	UHF Wireless Microphones – Bodypack Transmitter
Type identification	:	SK 300 G4, SK 500 G4, SK 100 G4
HMN	:	-/-
PMN	:	ewG4
HVIN	:	SK 300 G4, SK 500 G4, SK 100 G4
FVIN	:	1.1.0
S/N serial number	:	Band Aw+: 1347000011 Band Gw1: 1347000011
HW hardware status	:	525479_20
SW software status	:	1.1.0
Frequency band	:	470 MHz to 608 MHz Band Aw+: 470 MHz to 558 MHz also available as sub-bands A1: 470 MHz to 516 MHz A: 516 MHz to 558 MHz AS: 520 MHz to 558 MHz Band Gw1: 558 MHz to 608 MHz also available as sub-band G: 566 MHz to 608 MHz
Type of radio transmission	:	Modulated carrier
Use of frequency spectrum	:	
Type of modulation	:	Analog FM
Number of channels	:	-/-
Antenna	:	Integrated antenna
Power supply	:	2.55 V to 3.45 V DC by 2 x AA batteries
Temperature range	:	-30°C to +50°C

5.2 Additional information

The content of the following annexes is defined in the QA. It may be that not all of the listed annexes are necessary for this report, thus some values in between may be missing.

Test setup- and EUT-photos are included in test report: 1-4298/17-01-32_AnnexA
 1-4298/17-01-32_AnnexB
 1-4298/17-01-32_AnnexD

6 Description of the test setup

Typically, the calibrations of the test apparatus are commissioned to and performed by an accredited calibration laboratory. The calibration intervals are determined in accordance with the DIN EN ISO/IEC 17025. In addition to the external calibrations, the laboratory executes comparison measurements with other calibrated test systems or effective verifications. Weekly chamber inspections and range calibrations are performed. Where possible, RF generating and signaling equipment as well as measuring receivers and analyzers are connected to an external high-precision 10 MHz reference (GPS-based or rubidium frequency standard).

In order to simplify the identification of the equipment used at some special tests, some items of test equipment and ancillaries can be provided with an identifier or number in the equipment list below (Lab/Item).

Agenda: Kind of Calibration

k	calibration / calibrated	EK	limited calibration
ne	not required (k, ev, izw, zw not required)	zw	cyclical maintenance (external cyclical maintenance)
ev	periodic self verification	izw	internal cyclical maintenance
Ve	long-term stability recognized	g	blocked for accredited testing
v/k!	Attention: extended calibration interval		
NK!	Attention: not calibrated	*)	next calibration ordered / currently in progress

6.1 Shielded fully anechoic chamber

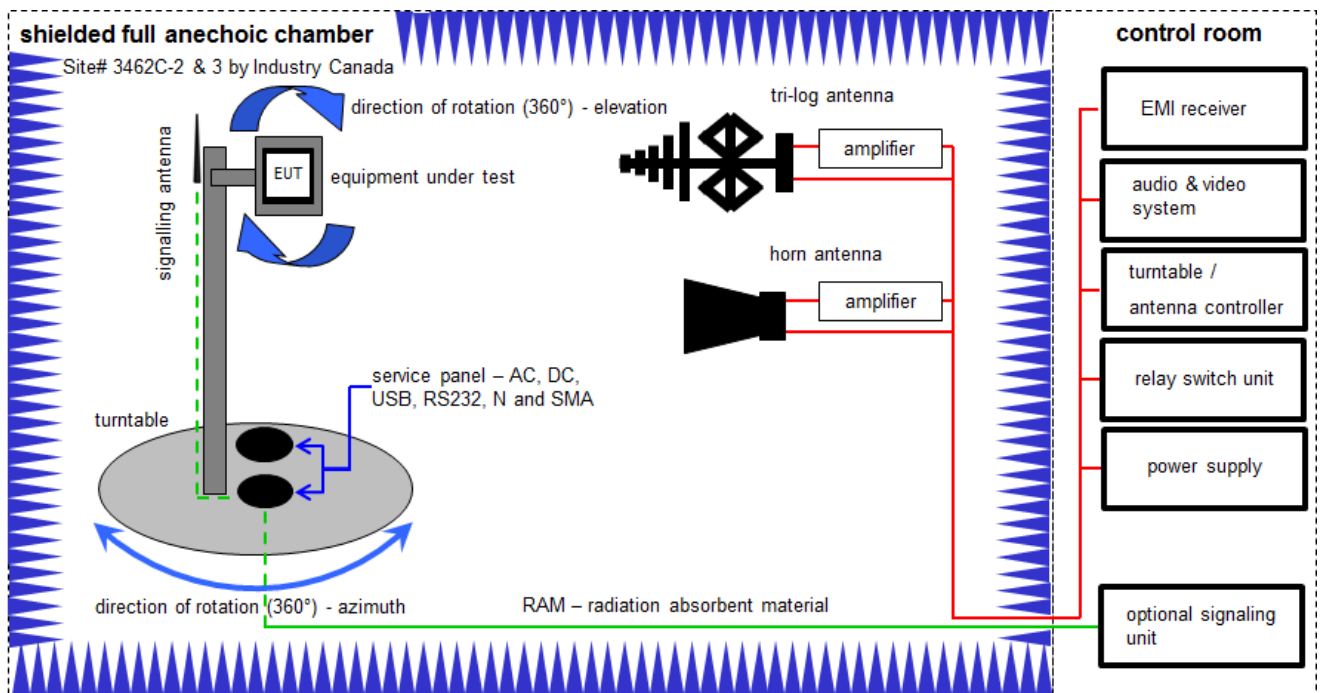

Measurement distance: tri-log antenna and horn antenna 3 meter

$$OP = AV + D - G + CA$$

(OP-radiated output power; AV-analyzer value; D-free field attenuation of measurement distance; G-antenna gain+amplifier gain; CA-loss signal path)

Example calculation:

$$OP [dBm] = -65.0 [dBm] + 50 [dB] - 20 [dBi] + 5 [dB] = -30 [dBm] (1 \mu W)$$

Equipment table:

No.	Lab / Item	Equipment	Type	Manufacturer	Serial No.	INV. No.	Kind of Calibration	Last Calibration	Next Calibration
1	B	Double-Ridged Waveguide Horn Antenna 1-18.0GHz	3115	EMCO	8812-3088	300001032	vKI!	07.07.2017	06.07.2019
2	B	Highpass Filter	WHK1.1/15G-10SS	Wainwright	37	400000148	ne	-/-	-/-
3	A	TRILOG Broadband Test-Antenna 30 MHz - 3 GHz	VULB9163	Schwarzbeck	318	300003696	k	23.05.2017	22.05.2020
4	B	Broadband Amplifier 0.5-18 GHz	CBLU5184540	CERNEX	22051	300004483	ev	-/-	-/-
5	A, B	4U RF Switch Platform	L4491A	Agilent Technologies	MY50000032	300004510	ne	-/-	-/-
6	A, B	Computer	Intel Core i3 3220/3,3 GHz, Prozessor	-/-	2V2403033A54 21	300004591	ne	-/-	-/-
7	A, B	NEXIO EMV-Software	BAT EMC V3.16.0.49	EMCO	-/-	300004682	ne	-/-	-/-
8	A, B	Anechoic chamber	-/-	TDK	-/-	300003726	ne	-/-	-/-
9	A, B	EMI Test Receiver 9kHz-26,5GHz	ESR26	R&S	101376	300005063	k	14.12.2017	13.12.2018

6.2 RF measurements normal and extreme conditions

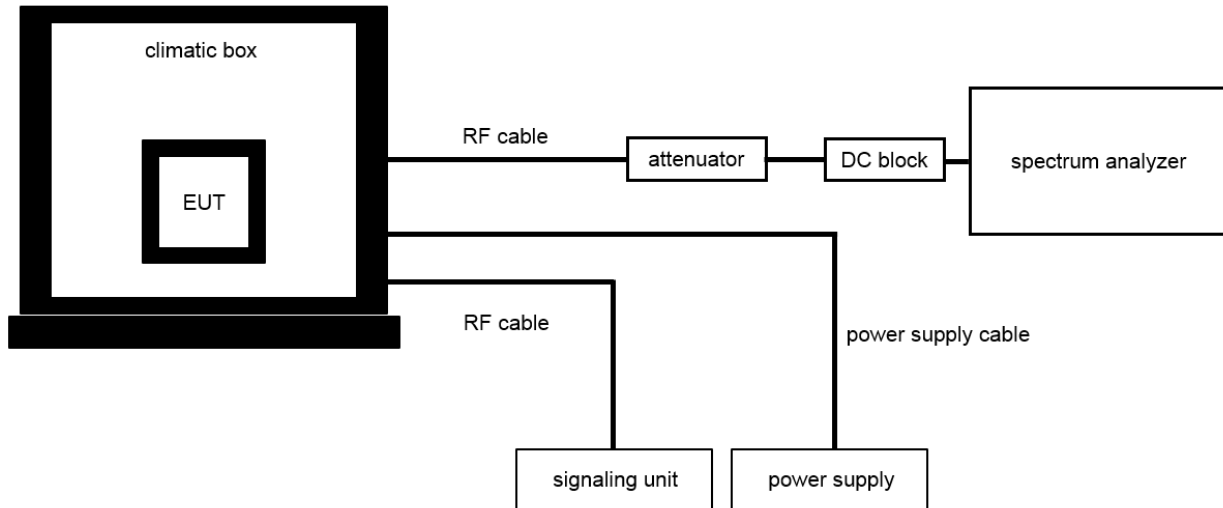

$OP = AV + CA$
(OP-output power; AV-analyzer value; CA-loss signal path)

Example calculation:

$OP [dBm] = 6.0 [dBm] + 11.7 [dB] = 17.7 [dBm] (58.88 \text{ mW})$

Equipment table:

No.	Lab / Item	Equipment	Type	Manufacturer	Serial No.	INV. No.	Kind of Calibration	Last Calibration	Next Calibration
1	A, B, C	Isolating Transformer	RT5A	Grundig	12780	300001166	ev	-/-	-/-
2	A, B, C	Signal- and Spectrum Analyzer	FSW26	R&S	101455	300004528	k	20.12.2017	19.12.2018
3	A	Climatic Box	VT 4011	Voetsch Industrietechnik	58566230600010	300005363	ev	01.06.2017	31.05.2019
4	B	Multifunction synthesizer DC-600 kHz	8904A	HP	2822A01203	300001367	vKI!	26.01.2017	25.01.2020
5	B, C	Radiocom. Analyzer	CMTA 84	R&S	894581/013	300001355	k	11.01.2018	10.01.2020
6	C	Audio Analyzer 2Hz - 300 kHz	UPD	R&S	841074/009	300001236	k	29.01.2018	28.01.2020

7 Sequence of testing

7.1 Sequence of testing radiated spurious 9 kHz to 30 MHz

Setup

- The equipment is set up to simulate normal operation mode as described in the user manual or defined by the manufacturer.
- If the EUT is a tabletop system, it is placed on a table with 0.8 m height.
- If the EUT is a floor standing device, it is placed directly on the turn table.
- Auxiliary equipment and cables are positioned to simulate normal operation conditions as described in ANSI C 63.4.
- The AC power port of the EUT (if available) is connected to a power outlet below the turntable.
- Measurement distance is 3 m (see ANSI C 63.4) – see test details.
- EUT is set into operation.

Premeasurement*

- The turntable rotates from 0° to 315° using 45° steps.
- The antenna height is 1 m.
- At each turntable position the analyzer sweeps with positive-peak detector to find the maximum of all emissions.

Final measurement

- Identified emissions during the pre-measurement are maximized by the software by rotating the turntable from 0° to 360°.
- Loop antenna is rotated about its vertical axis for maximum response at each azimuth about the EUT. (For certain applications, the loop antenna plane may also need to be positioned horizontally at the specified distance from the EUT)
- The final measurement is done in the position (turntable and elevation) causing the highest emissions with quasi-peak (as described in ANSI C 63.4).
- Final levels, frequency, measuring time, bandwidth, turntable position, correction factor, margin to the limit and limit will be recorded. A plot with the graph of the premeasurement and the limit is stored.

*)Note: The sequence will be repeated three times with different EUT orientations.

7.2 Sequence of testing radiated spurious 30 MHz to 1 GHz

Setup

- The equipment is set up to simulate normal operation mode as described in the user manual or defined by the manufacturer.
- If the EUT is a tabletop system, a table with 0.8 m height is used, which is placed on the ground plane.
- If the EUT is a floor standing device, it is placed on the ground plane with insulation between both.
- Auxiliary equipment and cables are positioned to simulate normal operation conditions as described in ANSI C 63.4.
- The AC power port of the EUT (if available) is connected to a power outlet below the turntable.
- Measurement distance is 10 m or 3 m (see ANSI C 63.4) – see test details.
- EUT is set into operation.

Premeasurement

- The turntable rotates from 0° to 315° using 45° steps.
- The antenna is polarized vertical and horizontal.
- The antenna height changes from 1 m to 3 m.
- At each turntable position, antenna polarization and height the analyzer sweeps three times in peak to find the maximum of all emissions.

Final measurement

- The final measurement is performed for at least six highest peaks according to the requirements of the ANSI C63.4.
- Based on antenna and turntable positions at which the peak values are measured the software maximize the peaks by changing turntable position $\pm 45^\circ$ and antenna height between 1 and 4 m.
- The final measurement is done with quasi-peak detector (as described in ANSI C 63.4).
- Final levels, frequency, measuring time, bandwidth, antenna height, antenna polarization, turntable angle, correction factor, margin to the limit and limit are recorded. A plot with the graph of the premeasurement with marked maximum final results and the limit is stored.

7.3 Sequence of testing radiated spurious 1 GHz to 12.75 GHz

Setup

- The equipment is set up to simulate normal operation mode as described in the user manual or defined by the manufacturer.
- If the EUT is a tabletop system, a 2-axis positioner with 1.5 m height is used.
- If the EUT is a floor standing device, it is placed directly on the turn table.
- Auxiliary equipment and cables are positioned to simulate normal operation conditions as described in ANSI C 63.4.
- The AC power port of the EUT (if available) is connected to a power outlet below the turntable.
- Measurement distance is 3 m (see ANSI C 63.4) – see test details.
- EUT is set into operation.

Premeasurement

- The turntable rotates from 0° to 315° using 45° steps.
- The antenna is polarized vertical and horizontal.
- The antenna height is 1.5 m.
- At each turntable position and antenna polarization the analyzer sweeps with positive peak detector to find the maximum of all emissions.

Final measurement

- The final measurement is performed for at least six highest peaks according to the requirements of the ANSI C63.4.
- Based on antenna and turntable positions at which the peak values are measured the software maximizes the peaks by rotating the turntable from 0° to 360°. This measurement is repeated for different EUT-table positions (0° to 150° in 30°-steps) and for both antenna polarizations.
- The final measurement is done in the position (turntable, EUT-table and antenna polarization) causing the highest emissions with Peak and RMS detector (as described in ANSI C 63.4).
- Final levels, frequency, measuring time, bandwidth, turntable position, EUT-table position, antenna polarization, correction factor, margin to the limit and limit are recorded. A plot with the graph of the premeasurement with marked maximum final results and the limit is stored.

8 Measurement uncertainty

Measurement uncertainty	
Test case	Uncertainty
Transmitter output power	± 3 dB
Occupied bandwidth	± 3 kHz to 10 kHz (depends on the used RBW)
Transmitter frequency stability	± 1 Hz to 1 kHz (depends on the used RBW)
Transmitter unwanted emissions (radiated or conducted)	Radiated: ± 3 dB Conducted: ± 0.5 dB
Modulation characteristics	-/-
Necessary bandwidth (BN) for analogue systems	± 1 kHz (depends on the used RBW)
Frequency modulation	± 3 kHz (depends on the used RBW)
Spurious emissions conducted below 30 MHz (AC conducted)	± 2.6 dB

9 Summary of measurement results

<input checked="" type="checkbox"/>	No deviations from the technical specifications were ascertained
<input type="checkbox"/>	There were deviations from the technical specifications ascertained
<input type="checkbox"/>	This test report is only a partial test report. The content and verdict of the performed test cases are listed below.

TC Identifier	Description	Verdict	Date	Remark
RF-Testing	FCC Part 74 RSS - 210, Issue 9 RSS-Gen Issue 4	See table!	2018-03-20	-/-

Test specification clause	Test case	Temperature conditions	Voltage conditions	C	NC	NA	NP	Remark
FCC Part 74.861 (e)(1)(ii) FCC Part 2.1046) RSS-210 – G.3.1 RSS-Gen – 6.12	Transmitter output power	Nominal	Nominal	<input checked="" type="checkbox"/>	<input type="checkbox"/>	<input type="checkbox"/>	<input type="checkbox"/>	-/-
FCC Part 74.861 (e)(5) FCC Part 2.1049 RSS-210 – G.3.2 RSS-Gen – 6.6	Occupied bandwidth	Nominal	Nominal	<input checked="" type="checkbox"/>	<input type="checkbox"/>	<input type="checkbox"/>	<input type="checkbox"/>	-/-
FCC Part 74.861 (e)(4) FCC Part 2.1055 RSS-210 – G.3.3 RSS-Gen – 6.11	Transmitter frequency stability	Nominal	Nominal	<input checked="" type="checkbox"/>	<input type="checkbox"/>	<input type="checkbox"/>	<input type="checkbox"/>	-/-
		Extreme	Extreme	<input checked="" type="checkbox"/>	<input type="checkbox"/>	<input type="checkbox"/>	<input type="checkbox"/>	
FCC Part 74.861 (e)(6) FCC Part 74.861 (e)(7) RSS-210 – G.3.4 ETSI EN 300 422-1 v1.4.2 (2011-08)	Transmitter unwanted emissions (radiated or conducted)	Nominal	Nominal	<input checked="" type="checkbox"/>	<input type="checkbox"/>	<input type="checkbox"/>	<input type="checkbox"/>	-/-
FCC Part 2.1047	Modulation characteristics	Nominal	Nominal	-/-				-/-
FCC Part 74.861 (e)(7) ETSI EN 300 422-1 v1.4.2 (2011-08)	Necessary bandwidth (BN) for analogue systems	Nominal	Nominal	<input checked="" type="checkbox"/>	<input type="checkbox"/>	<input type="checkbox"/>	<input type="checkbox"/>	-/-
FCC Part 74.861 (e)(3) RSS-210 – G.3.5.2	Frequency modulation	Nominal	Nominal	<input checked="" type="checkbox"/>	<input type="checkbox"/>	<input type="checkbox"/>	<input type="checkbox"/>	-/-
FCC Part 74.861 (e)(7) RSS-210 – G.3.4	Receiver spurious emissions	Nominal	Nominal	<input type="checkbox"/>	<input type="checkbox"/>	<input checked="" type="checkbox"/>	<input type="checkbox"/>	No receiver integrated!
FCC Part 15.107(a) FCC Part 15.207	Conducted emissions < 30 MHz	Nominal	Nominal	<input type="checkbox"/>	<input type="checkbox"/>	<input checked="" type="checkbox"/>	<input type="checkbox"/>	-/-

Note: C = Compliant; NC = Not compliant; NA = Not applicable; NP = Not performed

10 Additional comments

Reference documents: None

Special test descriptions: None

Configuration descriptions: TX Measurements are made with a device supporting band full Aw+ band. Results are reported separately for A1 and A band.

Test mode: No test mode available.
Test signal is applied to the transmitter.

Special software is used.
EUT is transmitting pseudo random data by itself

Antennas and transmit operating modes: **Operating mode 1 (single antenna)**

- *Equipment with 1 antenna,*
- *Equipment with 2 diversity antennas operating in switched diversity mode by which at any moment in time only 1 antenna is used,*
- *Smart antenna system with 2 or more transmit/receive chains, but operating in a mode where only 1 transmit/receive chain is used)*

Operating mode 2 (multiple antennas, no beamforming)

- *Equipment operating in this mode contains a smart antenna system using two or more transmit/receive chains simultaneously but without beamforming.*

Operating mode 3 (multiple antennas, with beamforming)

- *Equipment operating in this mode contains a smart antenna system using two or more transmit/receive chains simultaneously with beamforming.
In addition to the antenna assembly gain (G), the beamforming gain (Y) may have to be taken into account when performing the measurements.*

11 Measurement results

11.1 Transmitter output power

Measurement:

Measurement parameter	
Detector:	Peak (worst case) / Average (RMS)
Sweep time:	Auto / 20s
Resolution bandwidth:	> emission bandwidth
Video bandwidth:	> resolution bandwidth
Span:	> 2 times emissions bandwidth
Trace mode:	Max. hold
EUT configuration:	Peak: Unmodulated carrier RMS: Modulate the transmitter with a 2.5 kHz tone at a level 16 dB higher than that required to produce a frequency deviation of ± 75 kHz, or to produce 50% of the manufacturer's rated deviation, whichever is less.
Test setup:	See sub clause 6.1 – A
Measurement uncertainty:	See sub clause 8

Limits:

FCC & IC
470 MHz to 608 MHz 250 mW (average) / 24 dBm (average)

Result:

Channels	Transmitter output power (dBm)					
	Band Aw+ (Included Band A1)*		Band Aw+ (Included Band A)*		Band Gw1*	
	Peak	Average	Peak	Average	Peak	Average
Lowest	14.47	-/-	18.90	-/-	14.22	-/-
Middle	17.40	-/-	16.78	-/-	16.61	-/-
Highest	18.95	-/-	15.96	-/-	16.78	-/-

*) Output power set to 50 mW.

11.2 Occupied bandwidth

Measurement:

Measurement parameter	
Detector:	Peak
Sweep time:	Auto
Resolution bandwidth:	1 % to 5 % of the occupied bandwidth
Video bandwidth:	3 x resolution bandwidth
Span:	2 x emission bandwidth
Trace mode:	Max. hold
Analyzer function:	99% power occupied bandwidth function
EUT:	Modulated signal with max. frequency deviation
Test setup:	See sub clause 6.2 - B
Measurement uncertainty:	See sub clause 8

Limits:

FCC & IC
470 MHz to 608 MHz 200 kHz
Occupied bandwidth 99%. Other than single sideband or independent sideband transmitters - when modulated by a 2500 Hz tone at an input level 16 dB greater than that necessary to produce 50 percent modulation. The input level shall be established at the frequency of maximum response of the audio modulating circuit.

Result:

Occupied bandwidth (kHz)			
Channels	Band Aw+ (Included Band A1)	Band Aw+ (Included Band A)	Band Gw1
Lowest	98.3	96.3	98.6
Middle	96.7	97.0	97.3
Highest	96.4	95.8	97.2

Plots: Band Aw+ (Included Band A1)

Plot 1: lowest channel

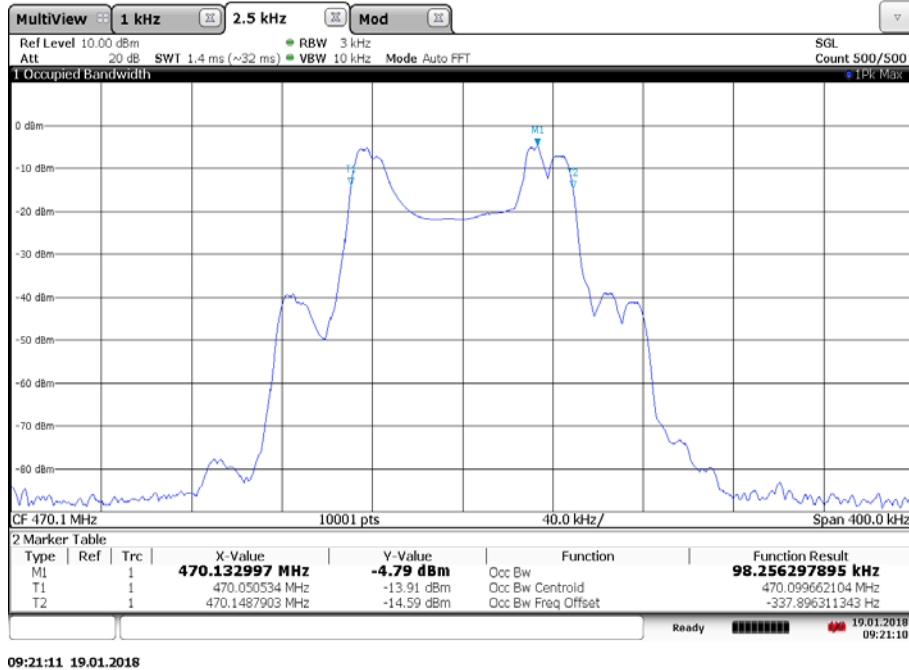

Plot 2: middle channel

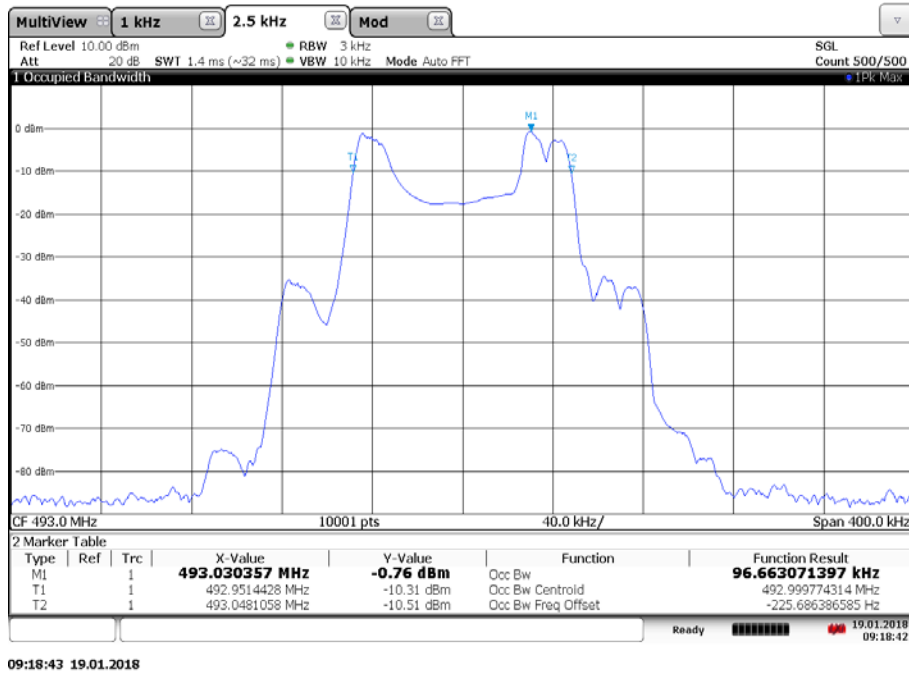

Plot 3: highest channel



Plots: Band Aw+ (Included Band A)

Plot 1: lowest channel



Plot 2: middle channel

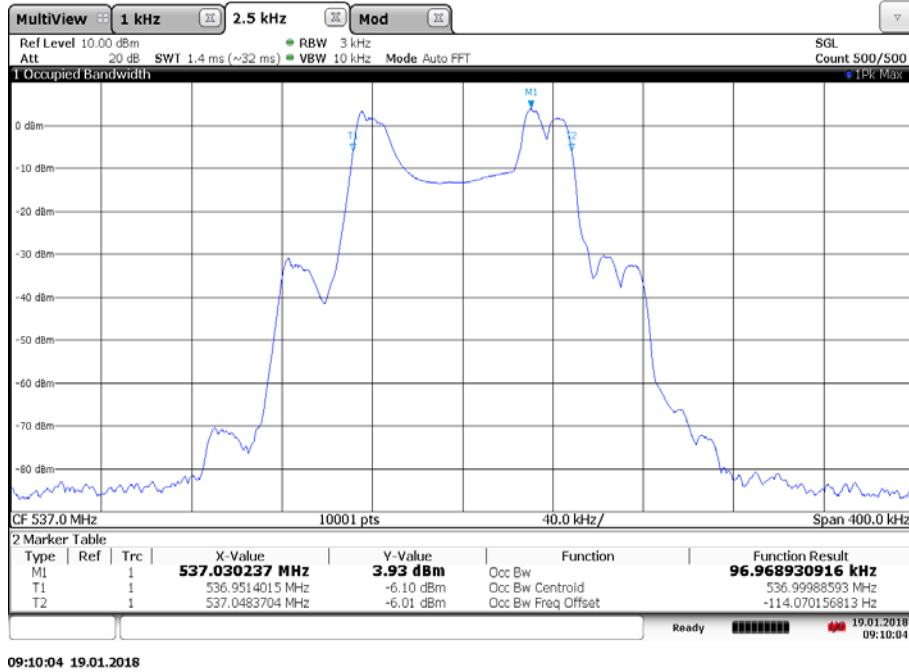

Plot 3: highest channel



Plots: Band Gw1

Plot 1: lowest channel

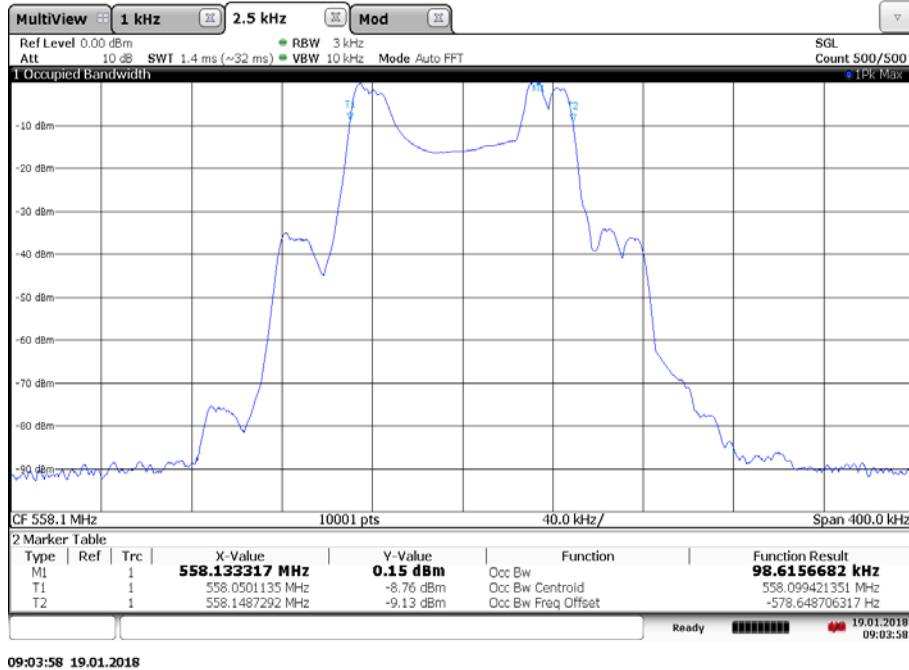

Plot 2: middle channel

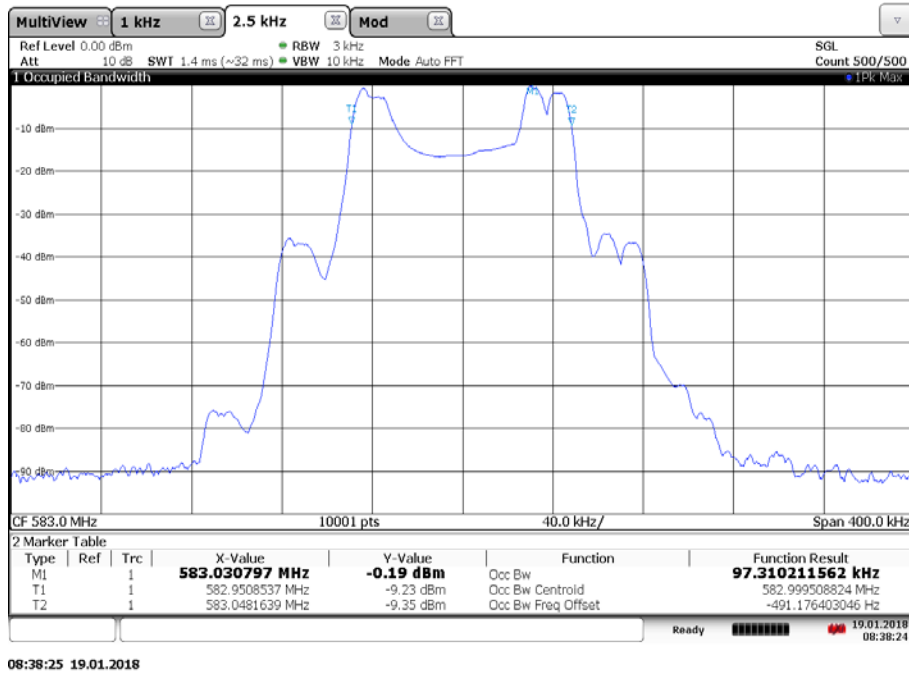

Plot 3: highest channel

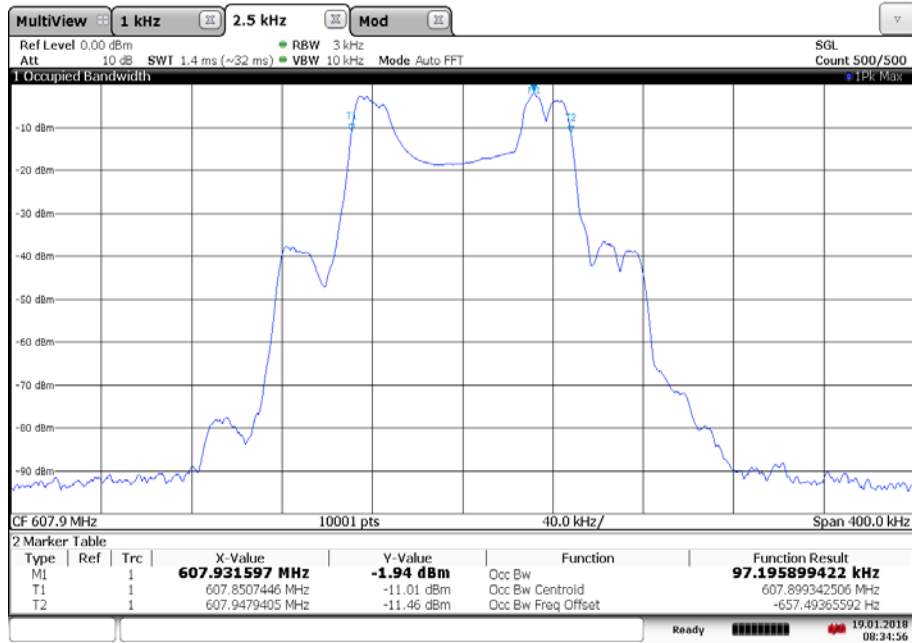

08:34:57 19.01.2018

11.3 Transmitter frequency stability

Measurement:

Measurement parameter	
Detector:	Peak
Sweep time:	Auto
Resolution bandwidth:	10 Hz
Video bandwidth:	3 x resolution bandwidth
Span:	wide enough to follow the frequency drift
Trace mode:	clear/write/view
EUT:	CW signal or MC with measurement method description
Test setup:	See sub clause 6.2 - A
Measurement uncertainty:	See sub clause 8

Limits:

FCC & IC
470 MHz to 608 MHz \pm 50 ppm

Results: Band Aw+ (Included Band A1), lowest channel

Temperature / Voltage	Frequency (MHz)	Deviation (kHz)	Deviation (ppm)
-30 °C / V_{nom}	470.098222	-1.778	-3.782
-20 °C / V_{nom}	470.099268	-0.732	-1.557
-10 °C / V_{nom}	470.100543	0.543	1.155
0 °C / V_{nom}	470.101103	1.103	2.346
+10 °C / V_{nom}	470.100815	0.815	1.734
+20 °C / V_{nom}	470.100210	0.210	0.447
+30 °C / V_{nom}	470.099929	-0.071	-0.151
+40 °C / V_{nom}	470.099648	-0.352	-0.749
+50 °C / V_{nom}	470.099573	-0.427	-0.908
+20 °C / $V_{nom} - 15\%$	470.100257	0.257	0.547
+20 °C / V_{nom}	470.100210	0.210	0.447
+20 °C / $V_{nom} + 15\%$	470.100236	0.236	0.502

Results: Band Aw+ (Included Band A1), middle channel

Temperature / Voltage	Frequency (MHz)	Deviation (kHz)	Deviation (ppm)
-30 °C / V_{nom}	492.996997	-1.101	-2.233
-20 °C / V_{nom}	492.999678	-0.322	-0.653
-10 °C / V_{nom}	493.000798	0.798	1.619
0 °C / V_{nom}	493.000934	0.934	1.895
+10 °C / V_{nom}	493.000546	0.546	1.108
+20 °C / V_{nom}	493.000222	0.222	0.450
+30 °C / V_{nom}	492.999831	-0.170	-0.345
+40 °C / V_{nom}	492.999635	-0.366	-0.742
+50 °C / V_{nom}	492.999488	-0.512	-1.039
+20 °C / $V_{nom} - 15\%$	493.000286	0.286	0.580
+20 °C / V_{nom}	493.000222	0.222	0.450
+20 °C / $V_{nom} + 15\%$	493.000317	0.317	0.643

Results: Band Aw+ (Included Band A1), highest channel

Temperature / Voltage	Frequency (MHz)	Deviation (kHz)	Deviation (ppm)
-30 °C / V_{nom}	515.898248	-1.752	-3.554
-20 °C / V_{nom}	515.900164	0.164	0.333
-10 °C / V_{nom}	515.900747	0.747	1.515
0 °C / V_{nom}	515.900979	0.979	1.986
+10 °C / V_{nom}	515.900507	0.507	1.028
+20 °C / V_{nom}	515.900226	0.226	0.459
+30 °C / V_{nom}	515.899916	-0.084	-0.170
+40 °C / V_{nom}	515.899605	-0.395	-0.801
+50 °C / V_{nom}	515.899446	-0.556	-1.128
+20 °C / $V_{nom} - 15\%$	515.900284	0.284	0.576
+20 °C / V_{nom}	515.900226	0.226	0.459
+20 °C / $V_{nom} + 15\%$	515.900255	0.255	0.517

Results: Band Aw+ (Included Band A), lowest channel

Temperature / Voltage	Frequency (MHz)	Deviation (kHz)	Deviation (ppm)
-30 °C / V_{nom}	516.097013	0.013	0.025
-20 °C / V_{nom}	516.099775	-0.225	-0.436
-10 °C / V_{nom}	516.101066	1.066	2.066
0 °C / V_{nom}	516.101061	1.061	2.056
+10 °C / V_{nom}	516.100578	0.578	1.120
+20 °C / V_{nom}	516.100261	0.261	0.506
+30 °C / V_{nom}	516.099903	-0.097	-0.188
+40 °C / V_{nom}	516.099597	-0.403	-0.781
+50 °C / V_{nom}	516.099433	-0.567	-1.099
<hr/>			
+20 °C / V_{nom} - 15%	516.100254	0.254	0.492
+20 °C / V_{nom}	516.100261	0.261	0.506
+20 °C / V_{nom} + 15%	516.100240	0.240	0.465

Results: Band Aw+ (Included Band A), middle channel

Temperature / Voltage	Frequency (MHz)	Deviation (kHz)	Deviation (ppm)
-30 °C / V_{nom}	536.997154	-0.246	-0.458
-20 °C / V_{nom}	536.999869	-0.131	-0.244
-10 °C / V_{nom}	537.000874	0.874	1.628
0 °C / V_{nom}	537.001452	1.452	2.704
+10 °C / V_{nom}	537.001349	1.349	2.512
+20 °C / V_{nom}	537.000196	0.196	0.365
+30 °C / V_{nom}	536.999926	-0.074	-0.138
+40 °C / V_{nom}	536.999615	-0.385	-0.717
+50 °C / V_{nom}	536.999456	-0.544	-1.013
<hr/>			
+20 °C / V_{nom} - 15%	537.000276	0.273	0.508
+20 °C / V_{nom}	537.000196	0.196	0.370
+20 °C / V_{nom} + 15%	537.000251	0.251	0.468

Results: Band Aw+ (Included Band A), highest channel

Temperature / Voltage	Frequency (MHz)	Deviation (kHz)	Deviation (ppm)
-30 °C / V_{nom}	557.897382	-2.618	-4.693
-20 °C / V_{nom}	557.900004	0.004	0.007
-10 °C / V_{nom}	557.900733	0.733	1.314
0 °C / V_{nom}	557.901126	1.126	2.018
+10 °C / V_{nom}	557.900836	0.836	1.499
+20 °C / V_{nom}	557.900120	0.120	0.215
+30 °C / V_{nom}	557.899792	-0.209	-0.375
+40 °C / V_{nom}	557.899502	-0.498	-0.893
+50 °C / V_{nom}	557.899346	-0.654	-1.172
<hr/>			
+20 °C / V_{nom} - 15%	557.900190	0.189	0.339
+20 °C / V_{nom}	557.900120	0.120	0.215
+20 °C / V_{nom} + 15%	557.900221	0.221	0.396

Results: Band Gw1, lowest channel

Temperature / Voltage	Frequency (MHz)	Deviation (kHz)	Deviation (ppm)
-30 °C / V_{nom}	558.094087	-0.713	-1.278
-20 °C / V_{nom}	558.098904	-1.096	-1.964
-10 °C / V_{nom}	558.098904	-1.096	-1.964
0 °C / V_{nom}	558.100140	0.140	0.251
+10 °C / V_{nom}	558.100418	0.418	0.749
+20 °C / V_{nom}	558.100268	0.268	0.480
+30 °C / V_{nom}	558.100261	0.261	0.468
+40 °C / V_{nom}	558.100891	0.591	1.059
+50 °C / V_{nom}	558.100701	0.701	1.256
<hr/>			
+20 °C / V_{nom} - 15%	558.100273	0.273	0.489
+20 °C / V_{nom}	558.100268	0.268	0.480
+20 °C / V_{nom} + 15%	558.100245	0.245	0.439

Results: Band Gw1, middle channel

Temperature / Voltage	Frequency (MHz)	Deviation (kHz)	Deviation (ppm)
-30 °C / V_{nom}	582.994101	-0.999	-1.714
-20 °C / V_{nom}	582.997520	-2.480	-4.254
-10 °C / V_{nom}	582.999151	-0.849	-1.456
0 °C / V_{nom}	583.000215	0.215	0.369
+10 °C / V_{nom}	583.000288	0.288	0.494
+20 °C / V_{nom}	583.000266	0.266	0.456
+30 °C / V_{nom}	583.000305	0.305	0.523
+40 °C / V_{nom}	583.000389	0.389	0.667
+50 °C / V_{nom}	582.000769	0.770	1.321
+20 °C / $V_{nom} - 15\%$	583.000252	0.255	0.437
+20 °C / V_{nom}	583.000266	0.266	0.456
+20 °C / $V_{nom} + 15\%$	583.00301	0.301	0.516

Results: Band Gw1, highest channel

Temperature / Voltage	Frequency (MHz)	Deviation (kHz)	Deviation (ppm)
-30 °C / V_{nom}	607.893528	-0.072	-0.119
-20 °C / V_{nom}	607.897623	-2.377	-3.910
-10 °C / V_{nom}	607.899054	-0.946	-1.556
0 °C / V_{nom}	607.900176	0.176	0.290
+10 °C / V_{nom}	607.900303	0.303	0.499
+20 °C / V_{nom}	607.900213	0.213	0.350
+30 °C / V_{nom}	607.900138	0.138	0.227
+40 °C / V_{nom}	607.900359	0.359	0.591
+50 °C / V_{nom}	607.900817	0.817	1.344
+20 °C / $V_{nom} - 15\%$	607.900186	0.186	0.306
+20 °C / V_{nom}	607.900213	0.213	0.350
+20 °C / $V_{nom} + 15\%$	607.900129	0.129	0.212

11.4 Transmitter unwanted emissions (radiated)

Measurement:

Measurement parameter	
Detector:	RMS
Sweep time:	Auto
Resolution bandwidth:	See table below!
Video bandwidth:	See table below!
Span:	100 MHz steps!
Trace-Mode:	Max. hold
EUT:	MC with max frequency deviation
Used equipment:	See chapter 6.1- A / B
Measurement uncertainty:	See chapter 8

Frequency being measured	Measuring receiver bandwidth
25 MHz to 30 MHz	9 kHz to 10 kHz
30 MHz to 1 000 MHz	100 kHz
> 1 000 MHz	1 MHz

Limits:

FCC & IC (according to ETSI EN 300 422-1 v1.4.2 (2011-08))			
State	Max. spurious level		
	47 MHz to 74 MHz 87.5 MHz to 118 MHz 174 MHz to 230 MHz 470 MHz to 862 MHz	Other frequencies ≤ 1000 MHz	All frequencies > 1000 MHz
Operating	4.0 nW	250 nW	1.00 µW
Standby	2.0 nW	2.0 nW	20.0 nW

FCC & IC	
The mean power of emissions shall be attenuated below the mean output power of the transmitter in accordance with the following schedule:	
On any frequency removed from the operating frequency by more than 50 percent up to and including 100 percent of the authorized bandwidth: at least	25 dB
On any frequency removed from the operating frequency by more than 100 percent up to and including 250 percent of the authorized bandwidth	35 dB
On any frequency removed from the operating frequency by more than 250 percent of the authorized bandwidth: at least	43 + 10log ₁₀ (mean output power in watts) dB

Results:

carrier frequency (MHz)	unwanted emission frequency (MHz)	Limit	level (dB) / (dBm) or remark
No emissions were detected.			

Plots: Band Aw+ (Included Band A1)

Plot 1: lowest channel, spurious emissions, 25 MHz – 12.75 GHz

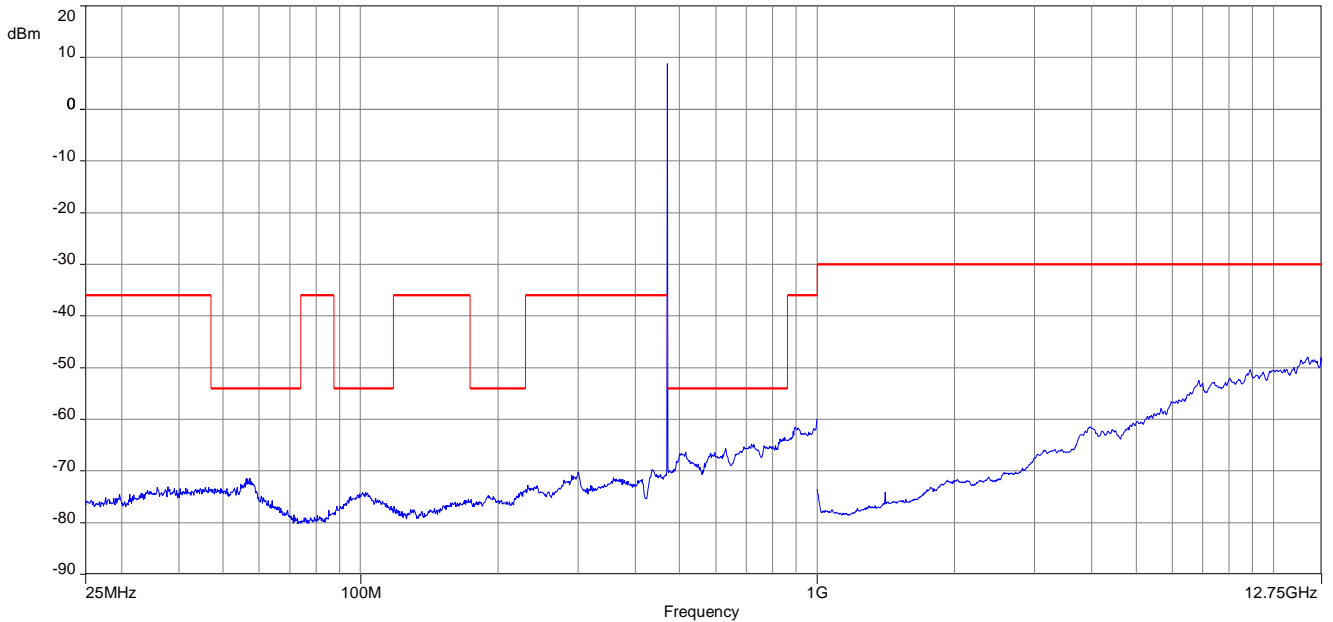

Plot 2: middle channel, spurious emissions, 25 MHz – 12.75 GHz

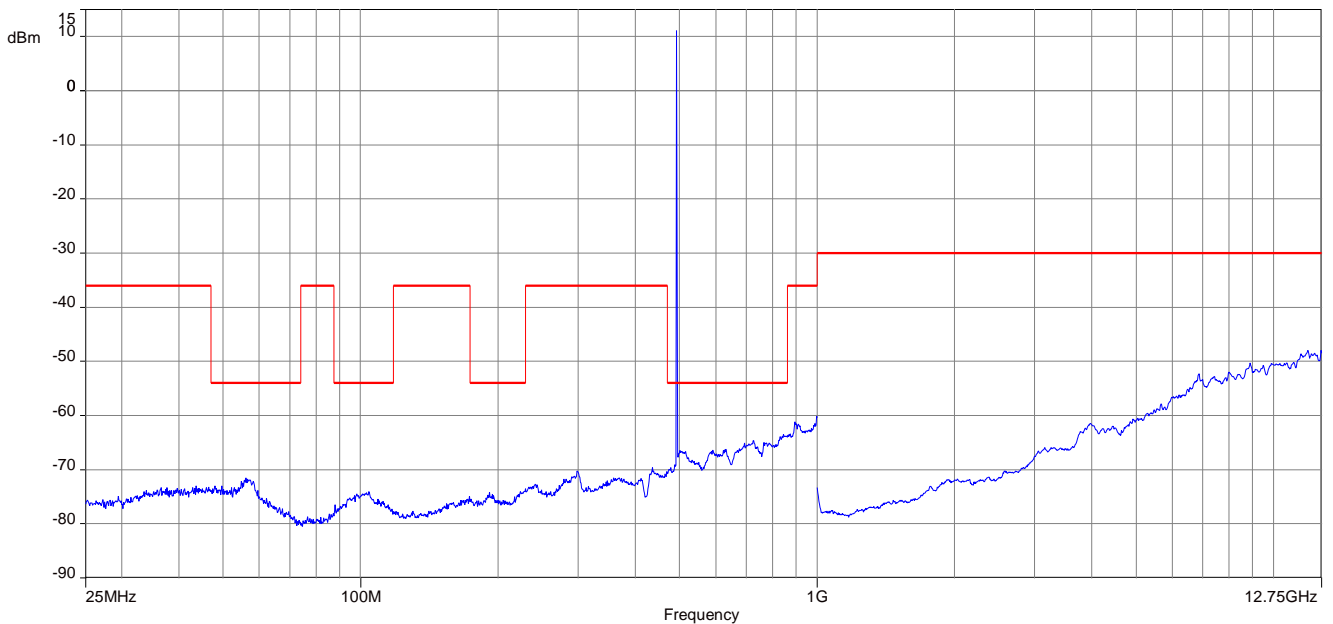

Plot 3: highest channel, spurious emissions, 25 MHz – 12.75 GHz

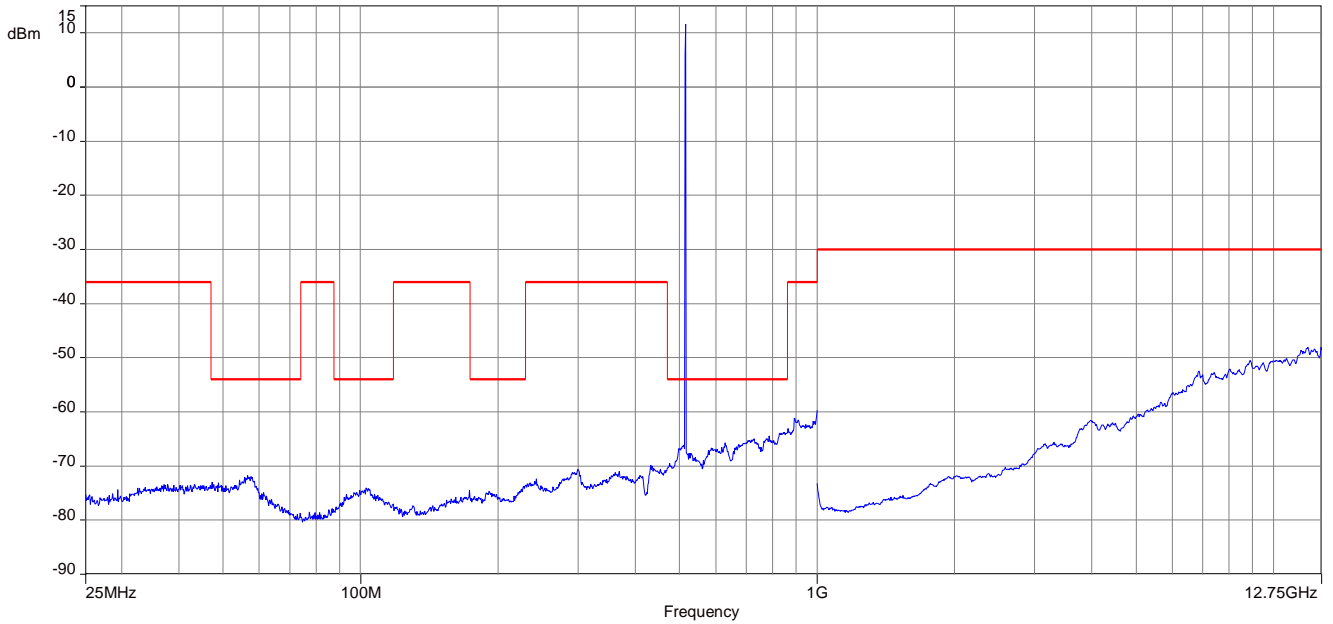

Plots: Band Aw+ (Included Band A)

Plot 1: lowest channel, spurious emissions, 25 MHz – 12.75 GHz

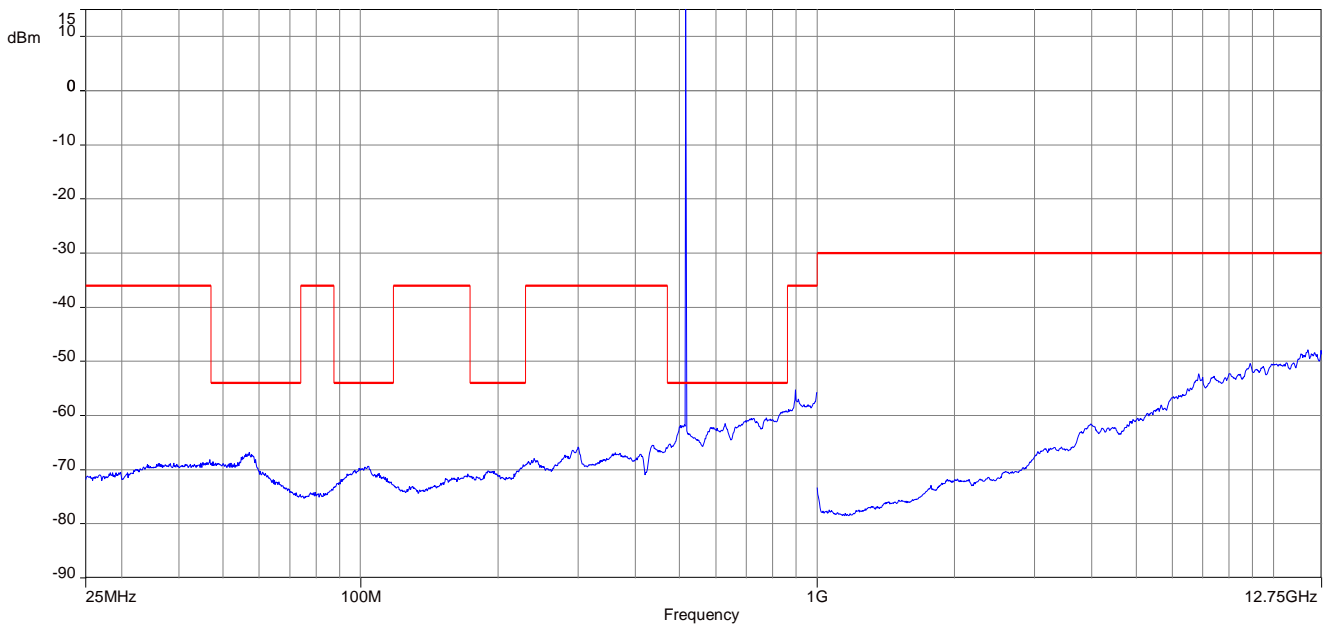

Plot 2: middle channel, spurious emissions, 25 MHz – 12.75 GHz

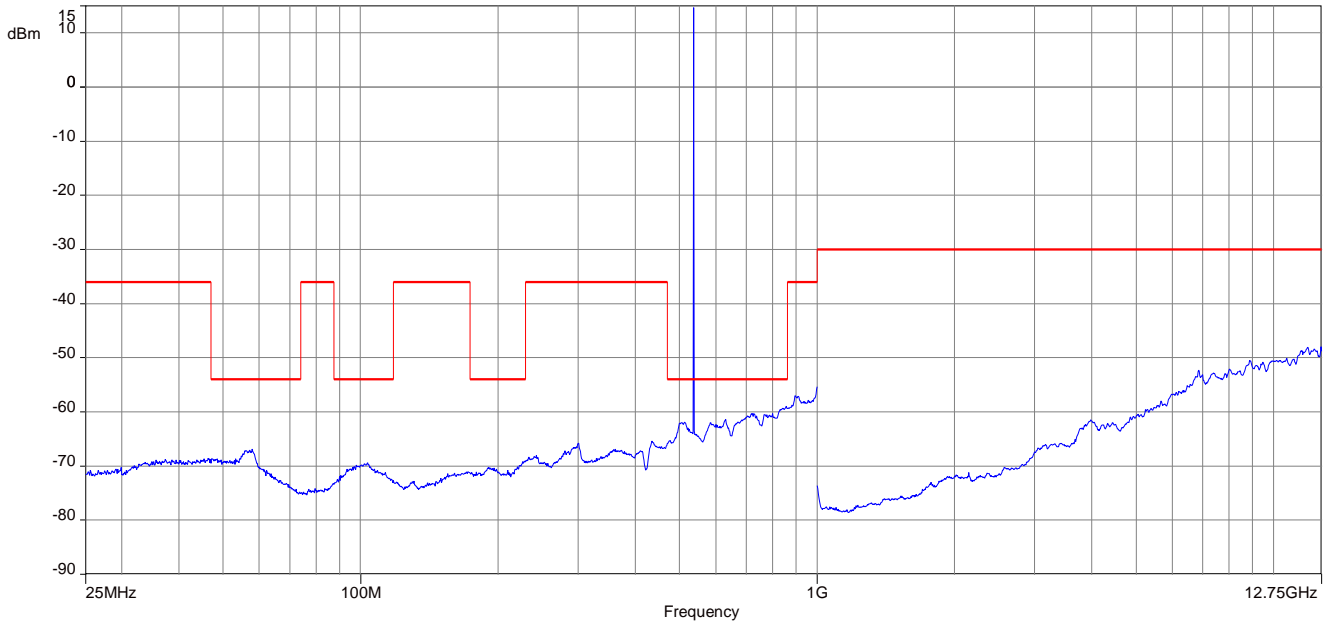

Plot 3: highest channel, spurious emissions, 25 MHz – 12.75 GHz

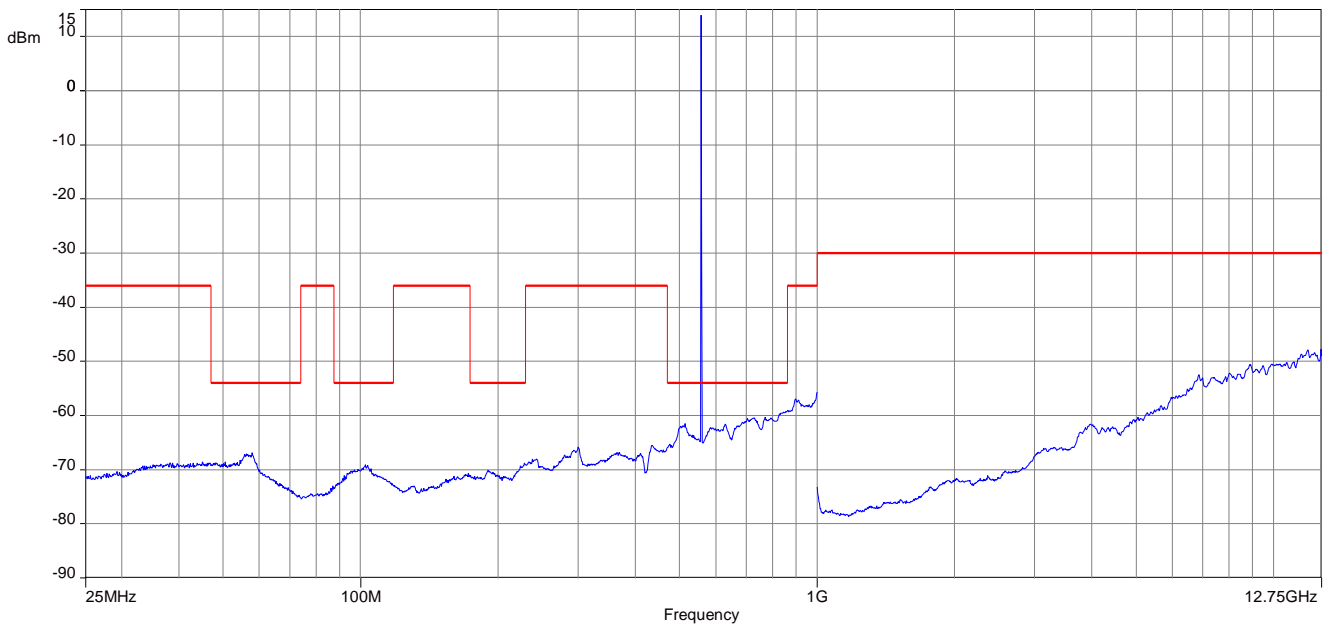

Plots: Band Gw1

Plot 1: lowest channel, spurious emissions, 25 MHz – 12.75 GHz

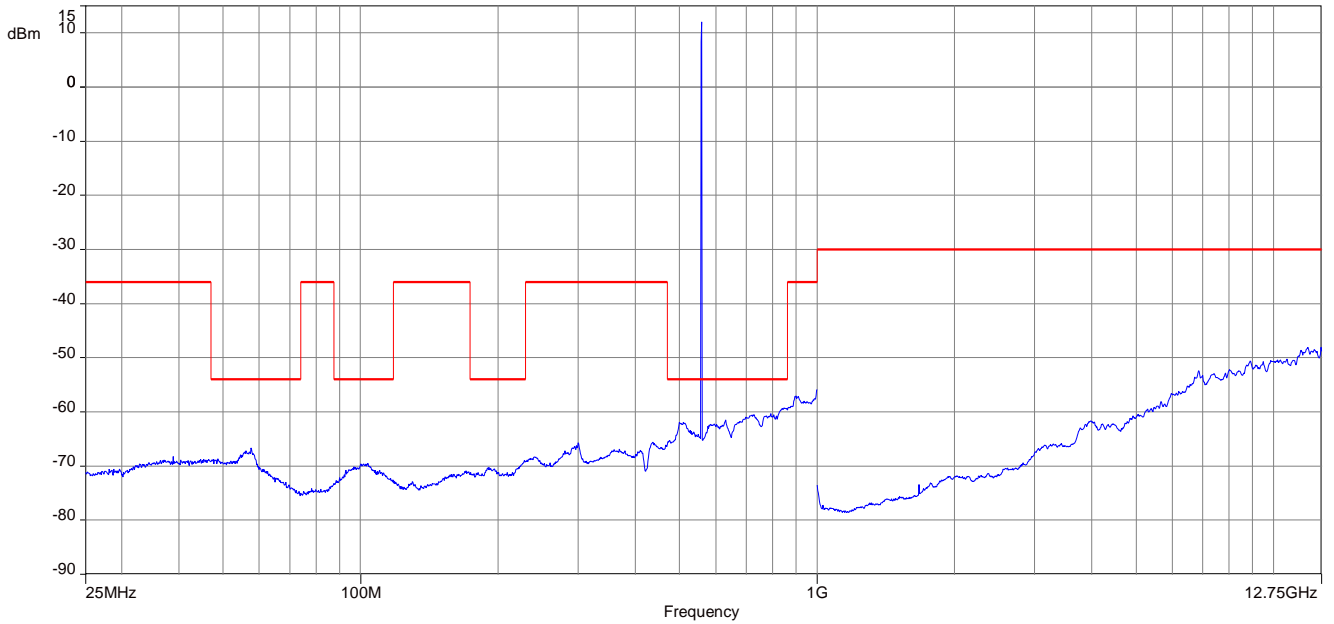

Plot 2: middle channel, spurious emissions, 25 MHz – 12.75 GHz

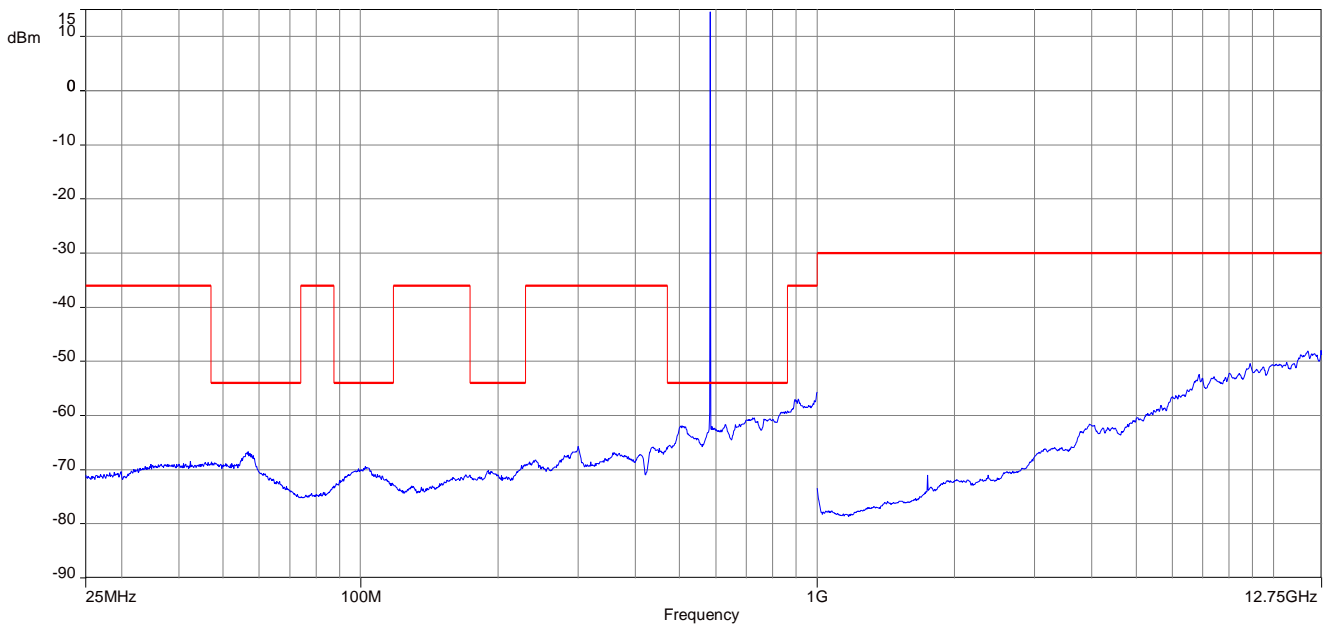

Plot 3: highest channel, spurious emissions, 25 MHz – 12.75 GHz

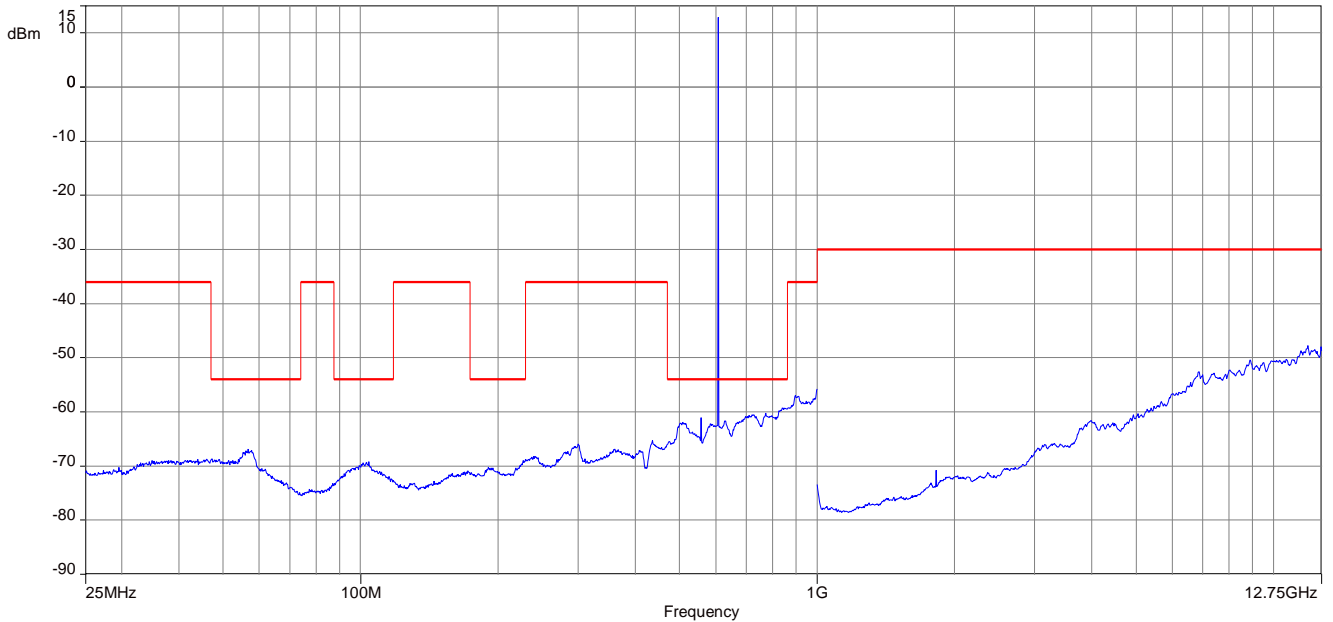

Plots: Band Aw+

Plot 1: lowest channel, spectrum mask

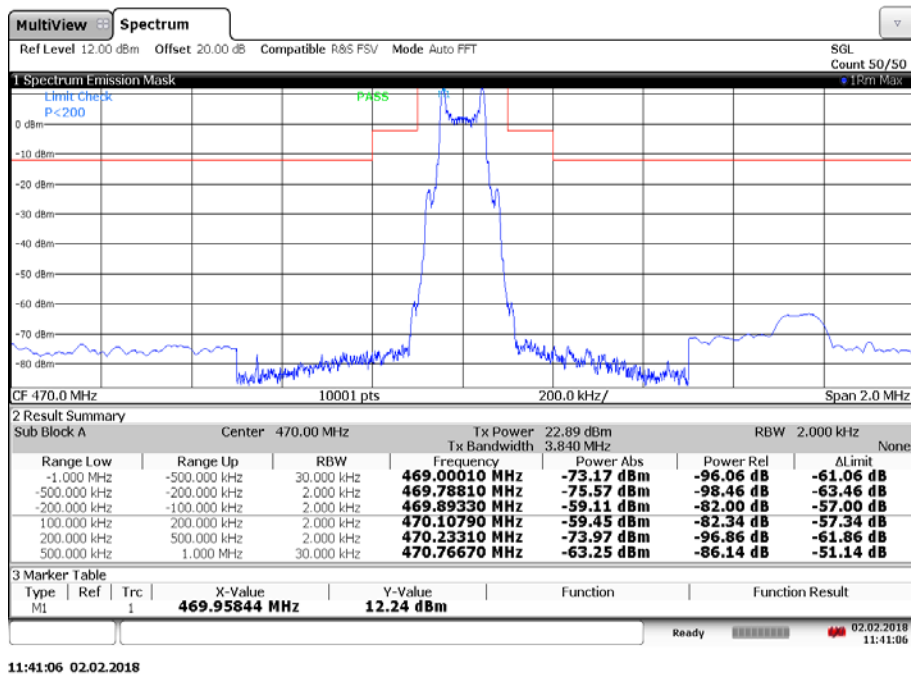

Plot 2: middle channel, spectrum mask

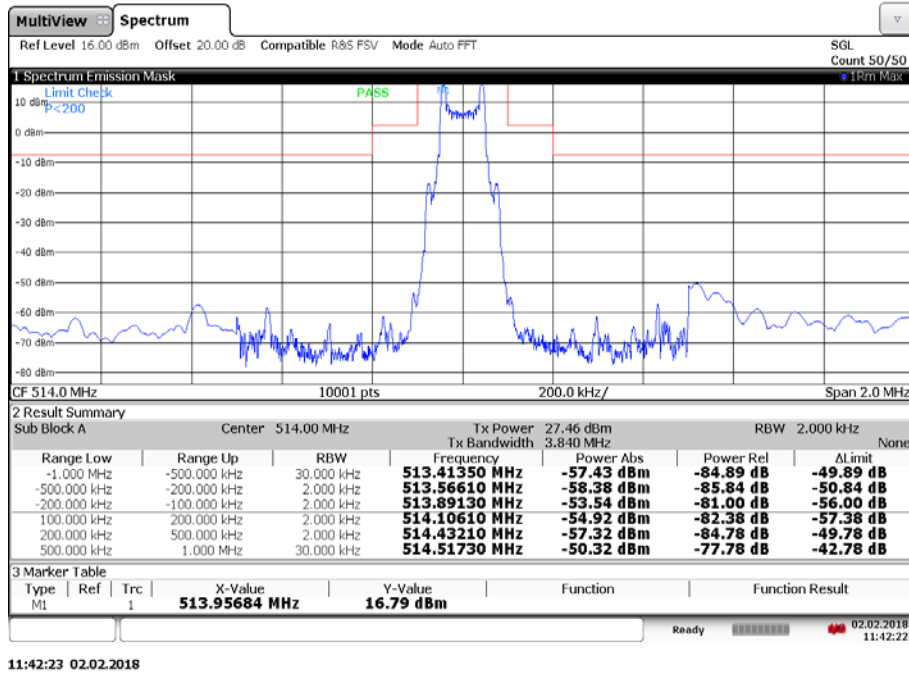

Plot 3: highest channel, spectrum mask

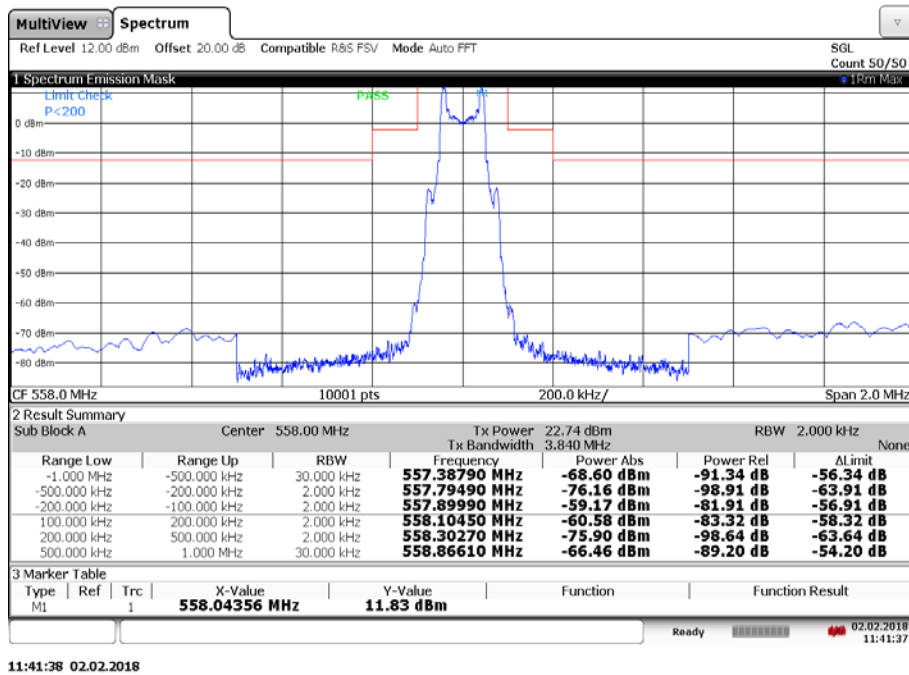

Plots: Band Gw1

Plot 1: lowest channel, spectrum mask

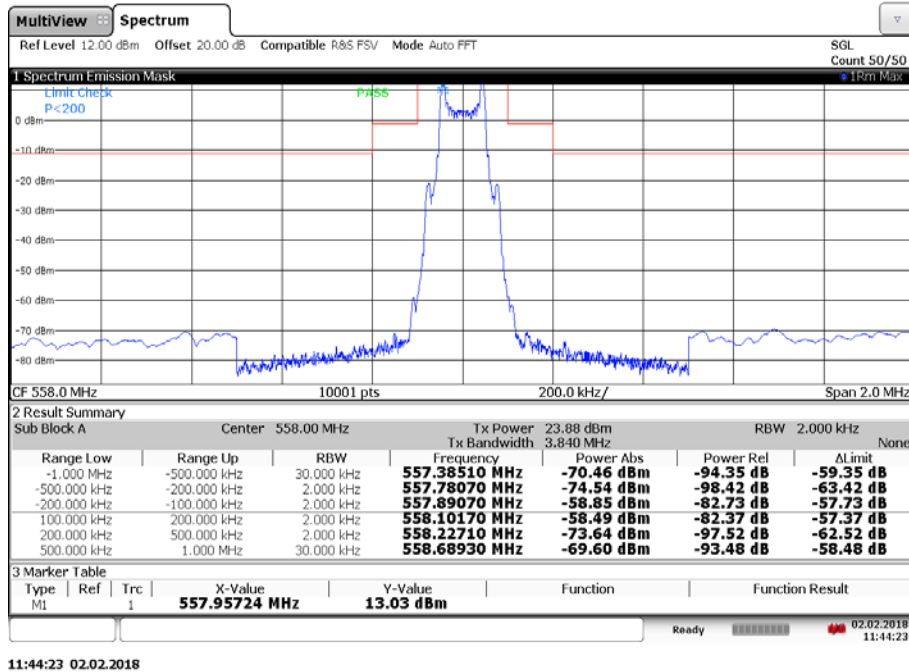

Plot 2: middle channel, spectrum mask

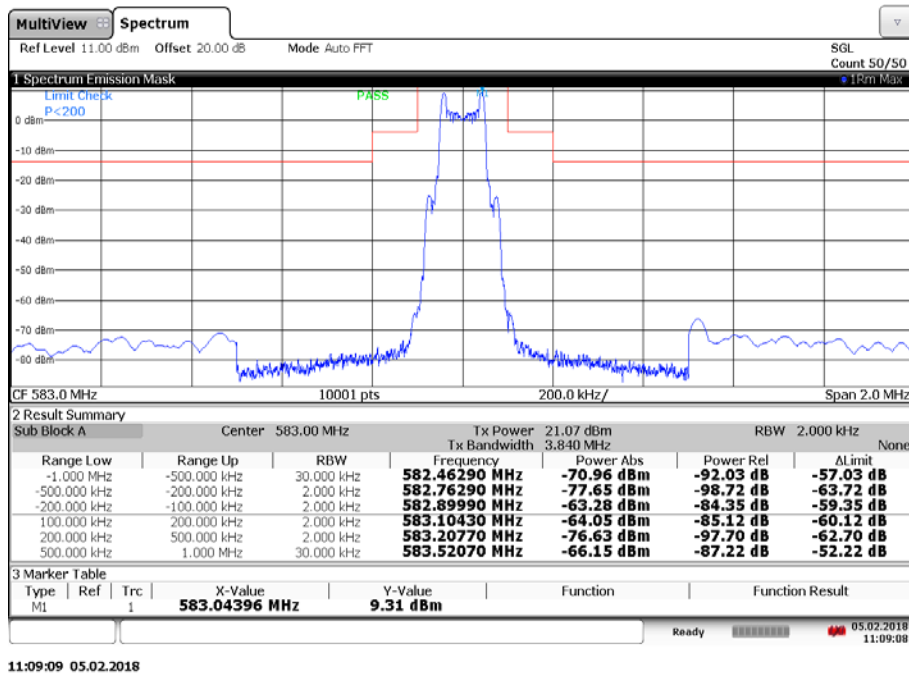

Plot 3: highest channel, spectrum mask

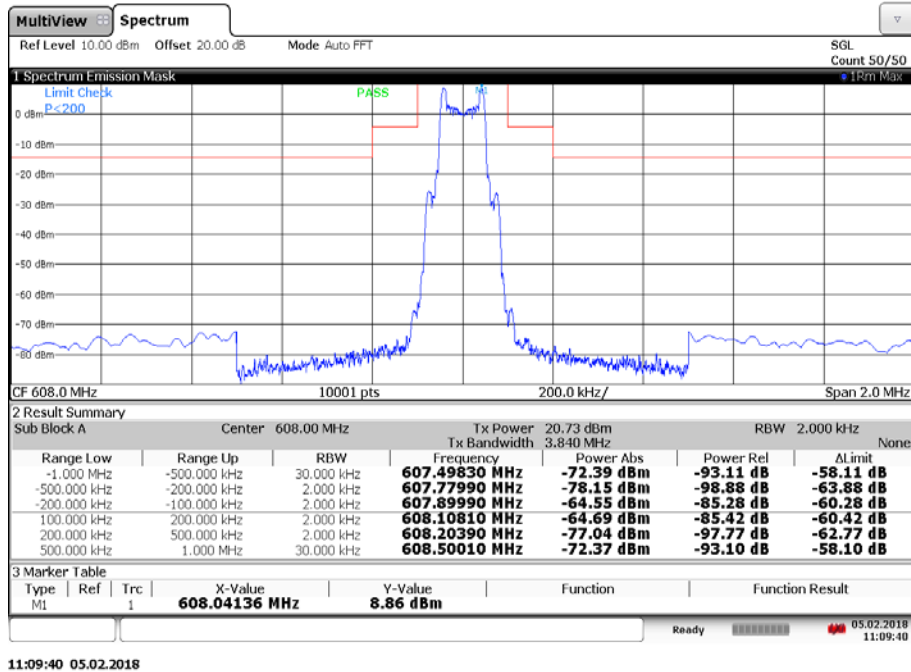

11.5 Modulation characteristics

Method of measurement:

The audio frequency response was measured in accordance with EIA/TIA 603. The plots shows 10 curves with different modulation levels, the test frequency is varied from 15 Hz to 20 kHz.

Plots: Band Aw+

Plot 1: lowest channel, 10 curves with voltage and frequency variation

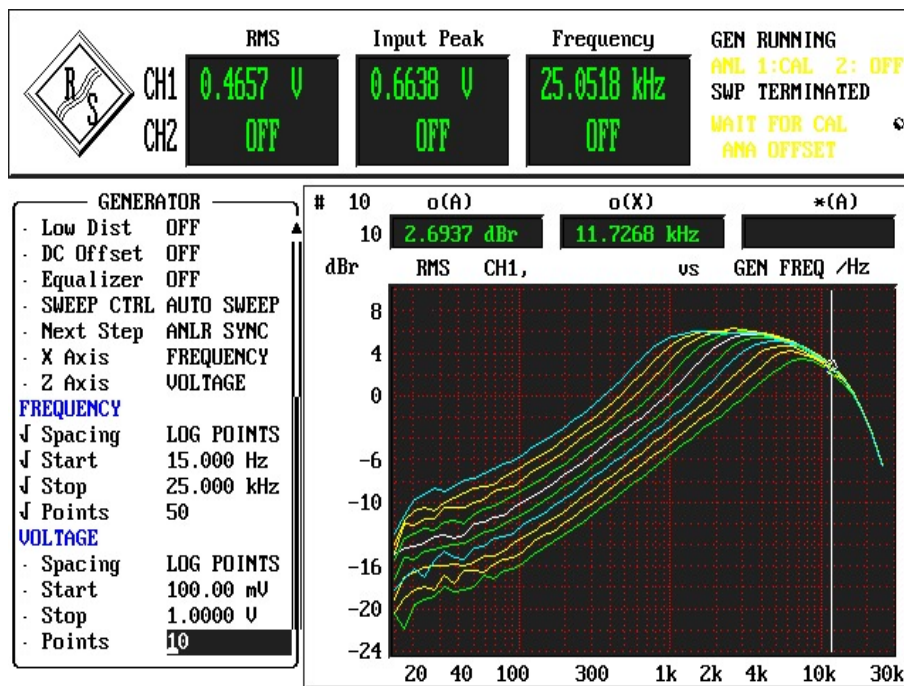

Plot 2: middle channel, 10 curves with voltage and frequency variation

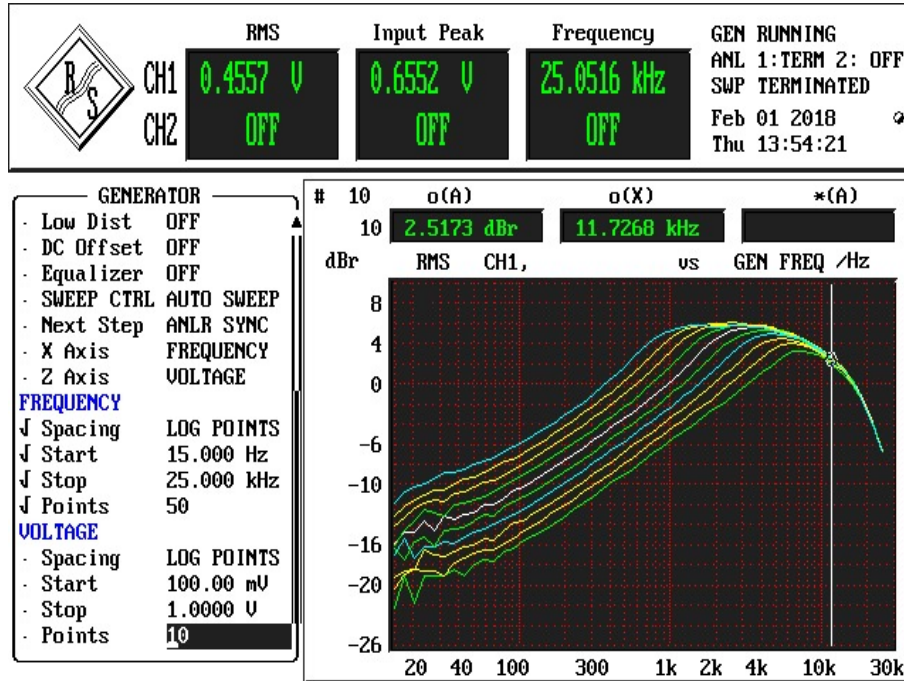

Plot 3: highest channel, 10 curves with voltage and frequency variation

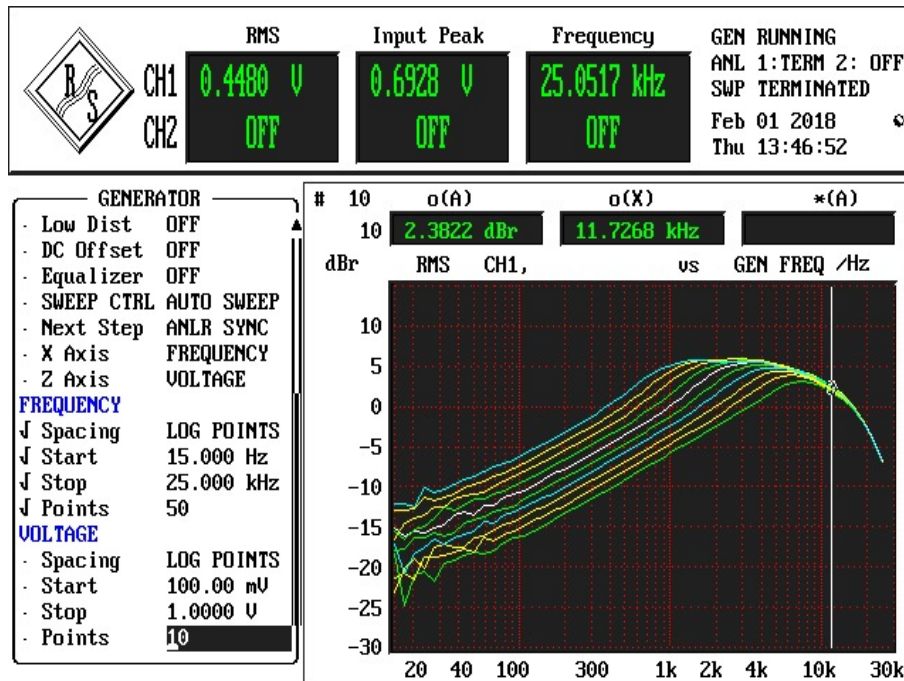

Plots: Band Gw1

Plot 1: lowest channel, 10 curves with voltage and frequency variation

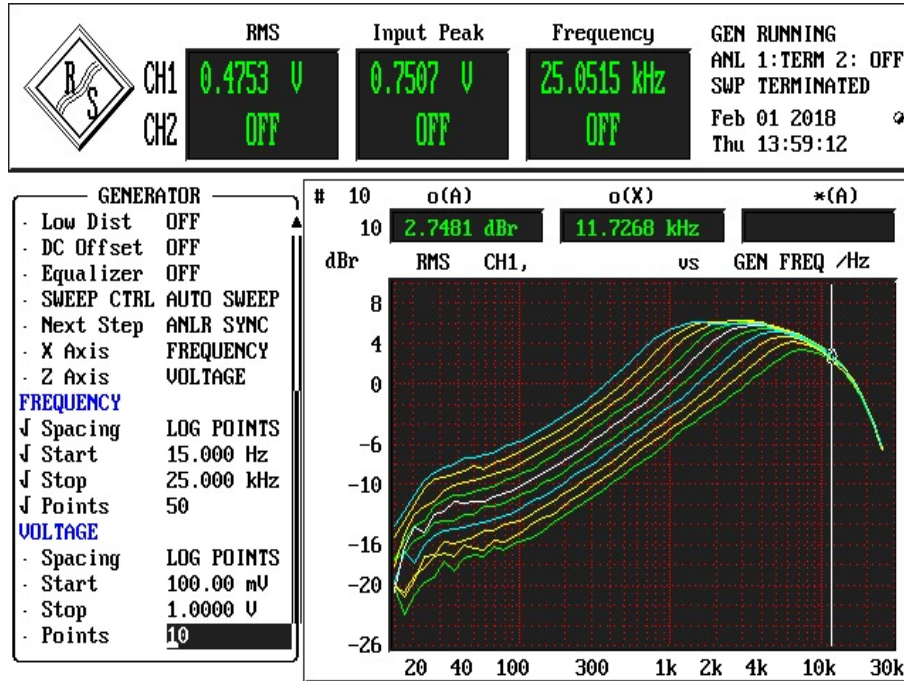

Plot 2: middle channel, 10 curves with voltage and frequency variation

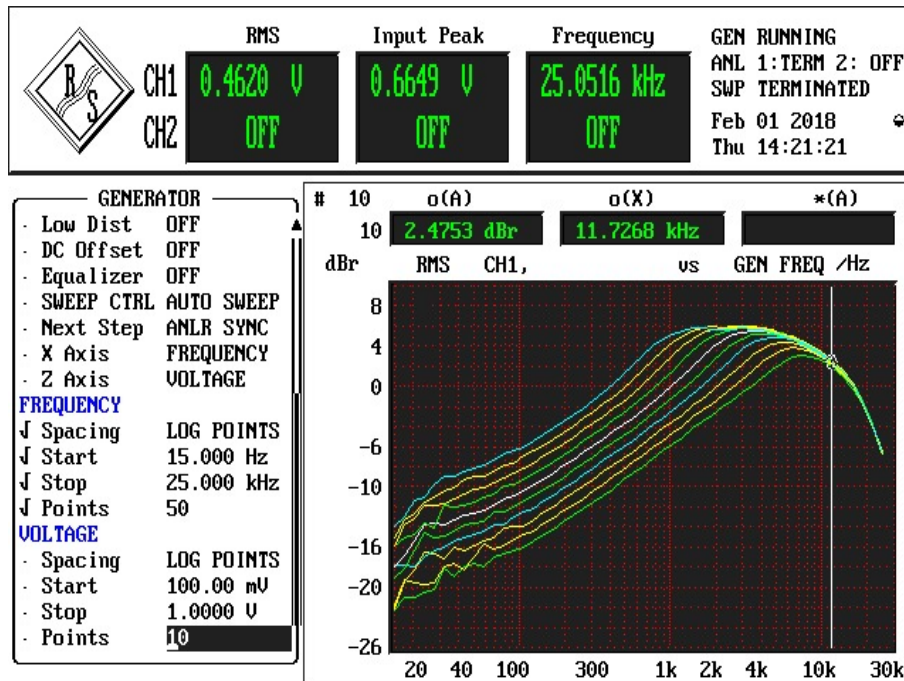

Plot 3: highest channel, 10 curves with voltage and frequency variation

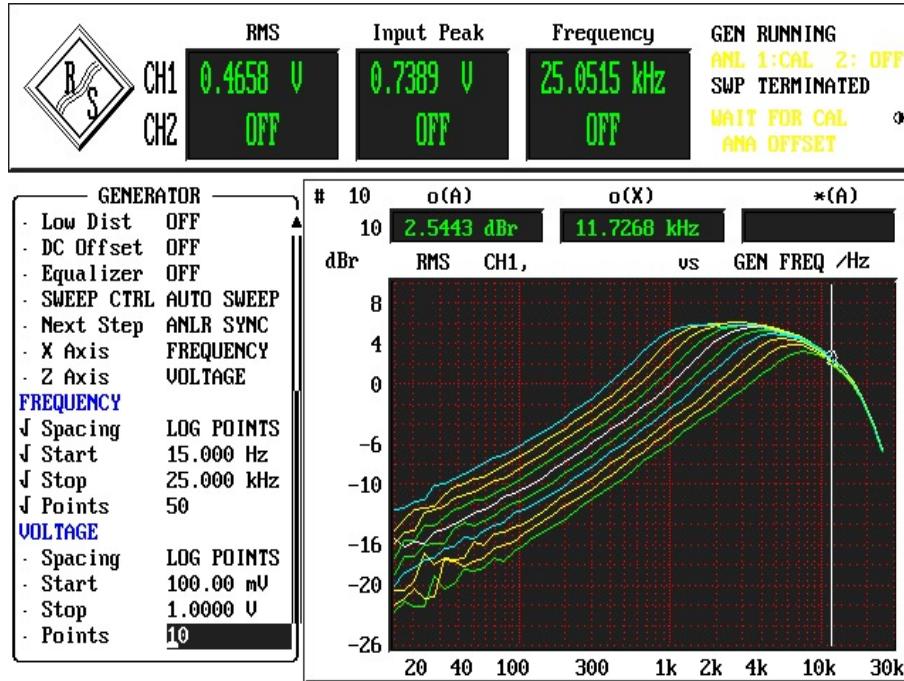

11.6 Necessary bandwidth (BN) for analogue systems

Measurement:

Measurement parameter	
Detector:	Peak / Average (-90 dBc point only)
Sweep time:	Auto
Resolution bandwidth:	1 kHz
Video bandwidth:	1 kHz
Span:	$f_c - 1 \text{ MHz}$ to $f_c + 1 \text{ MHz}$ (2 MHz)
Trace mode:	Max hold/view
EUT:	CW and MC
Test setup:	See sub clause 6.2 - C
Measurement uncertainty:	See sub clause 8

Limits: according to ETSI EN 300 422-1 v1.4.2 (2011-08)

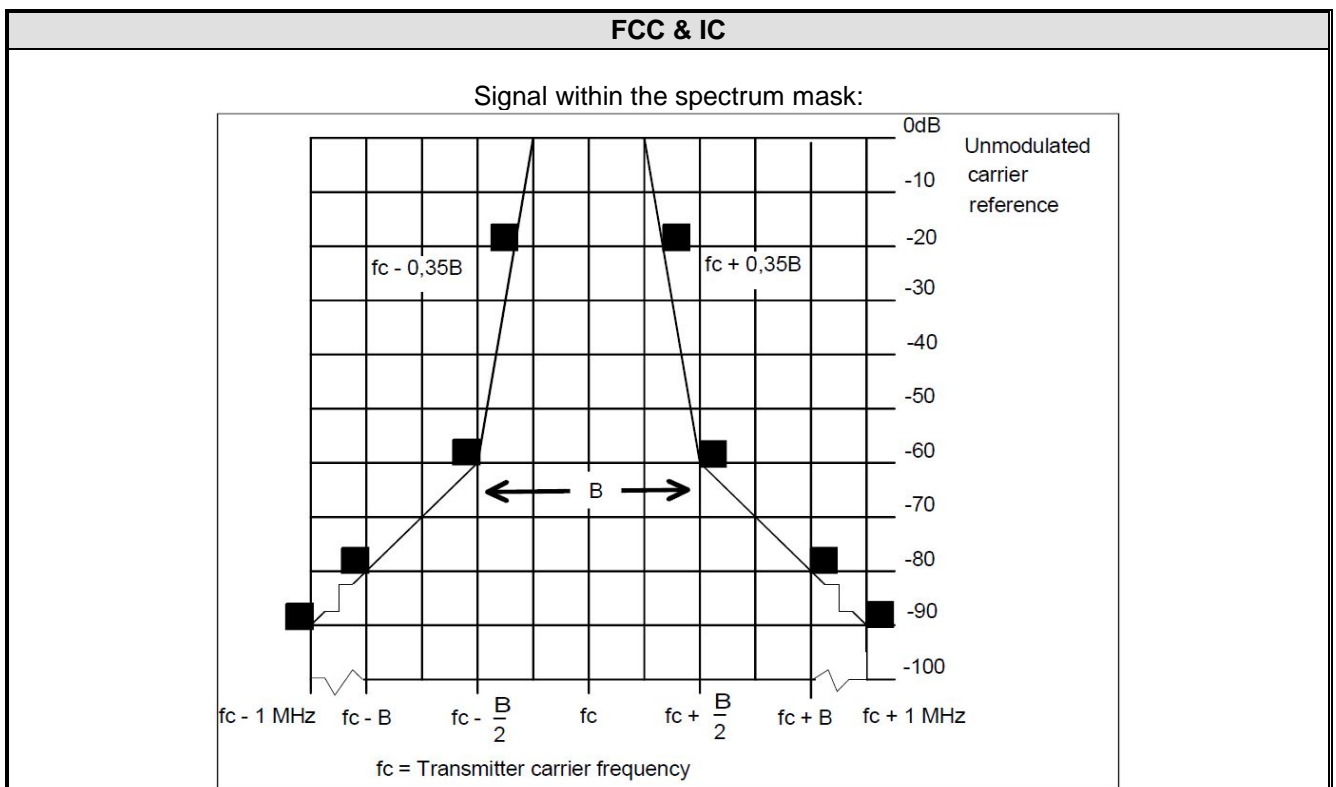

Plots: Band Aw+, lowest channel

Plot 1: Unmodulated carrier reference (with pilot-tone)

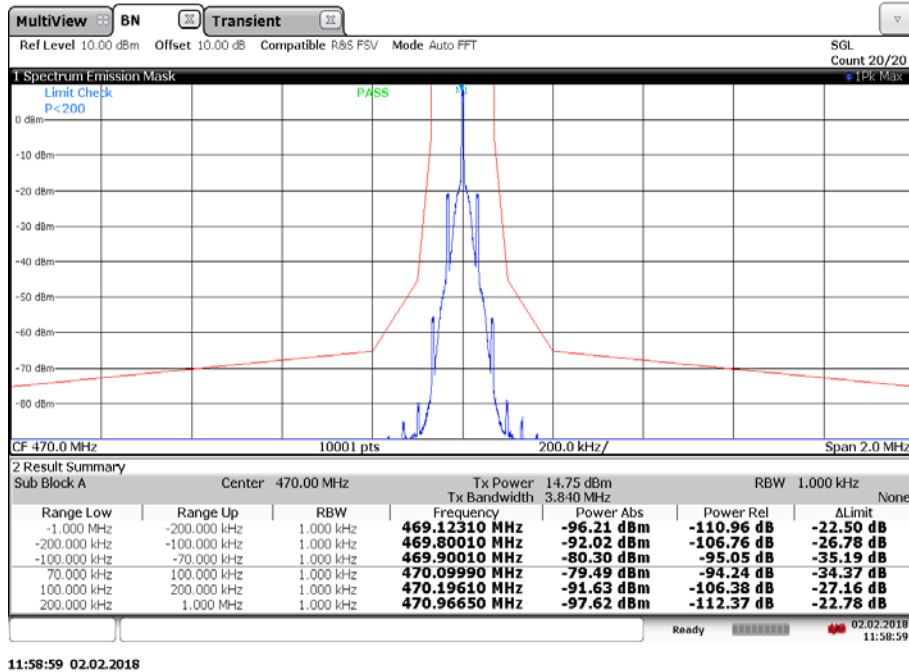

Plot 2: Modulated carrier with the weighted noise source

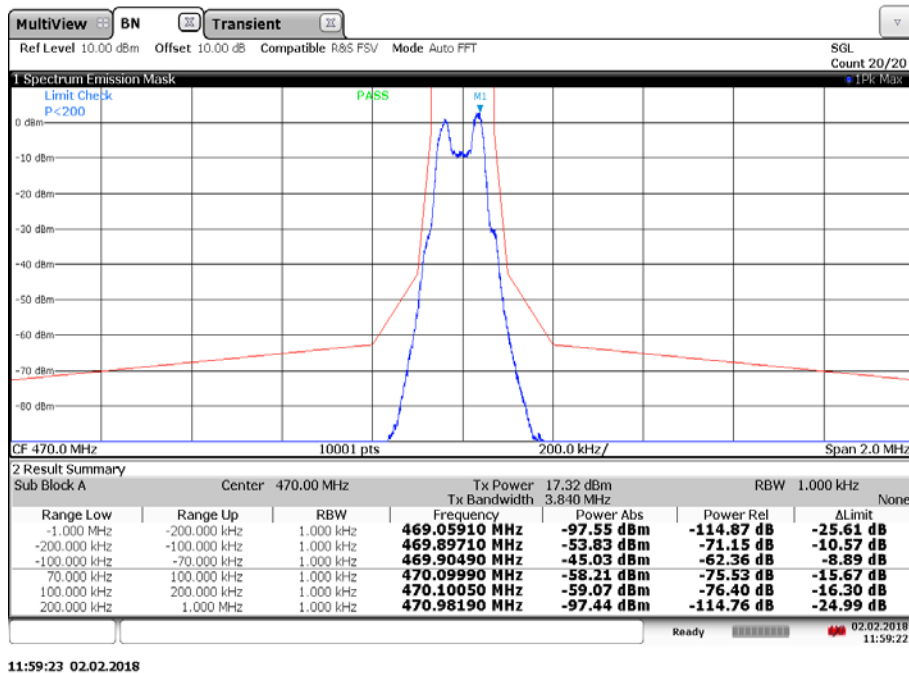

Plots: Band Aw+, middle channel

Plot 1: Unmodulated carrier reference (with pilot-tone)

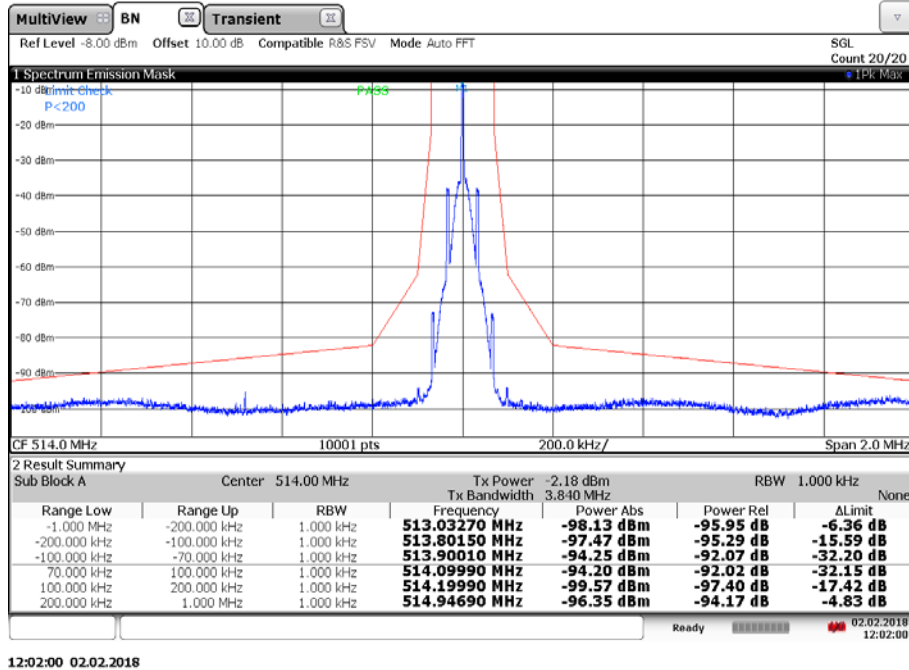

Plot 2: Modulated carrier with the weighted noise source

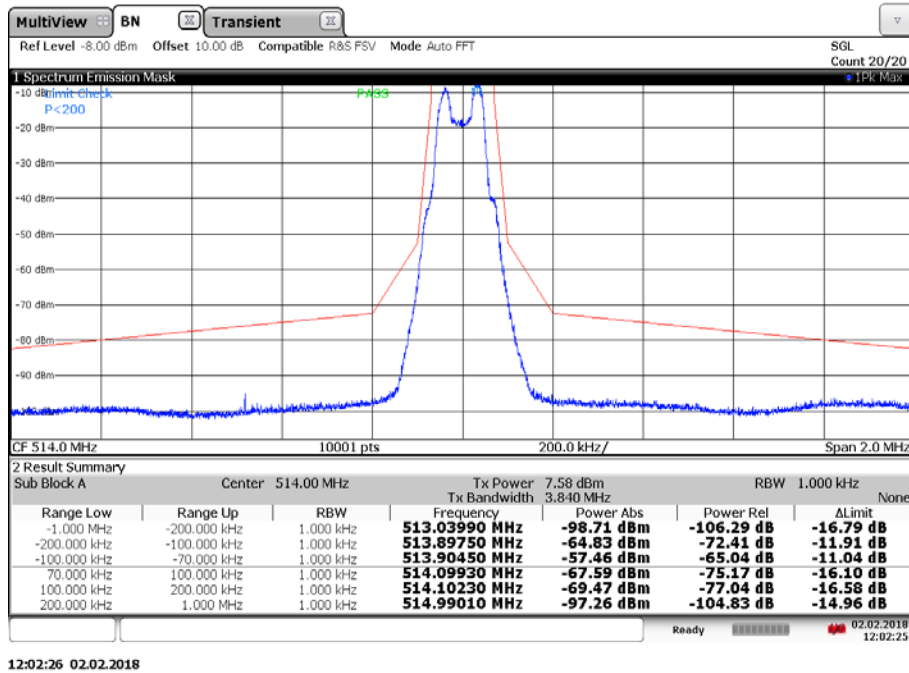

Plots: Band Aw+, highest channel

Plot 1: Unmodulated carrier reference (with pilot-tone)

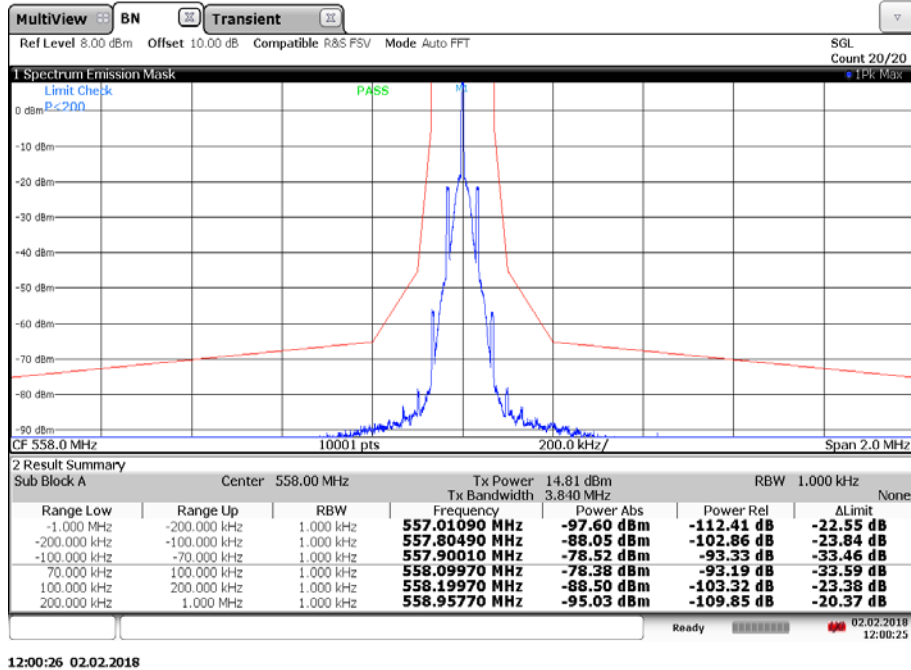

Plot 2: Modulated carrier with the weighted noise source

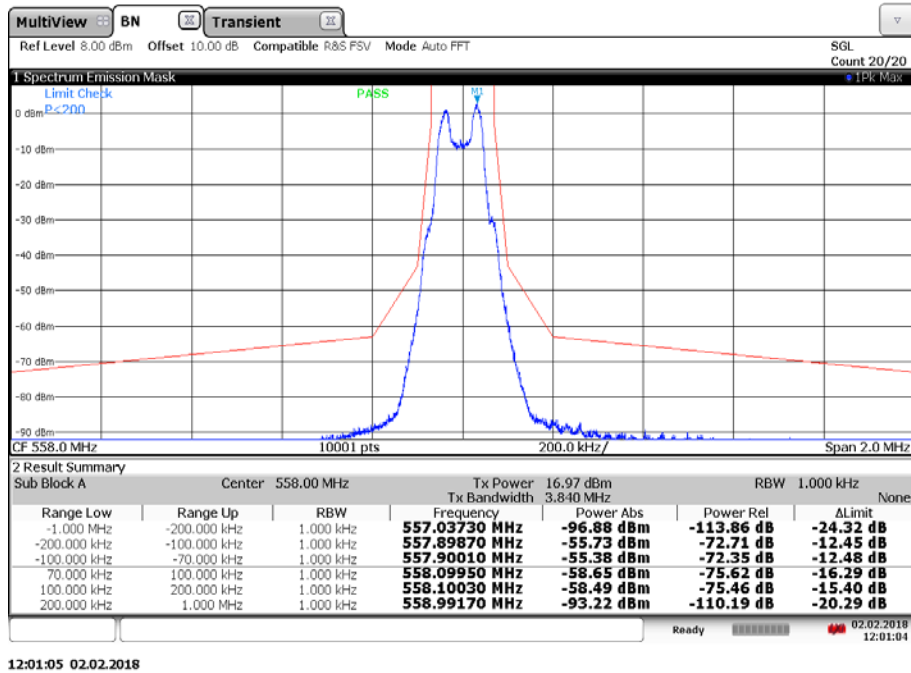

Plots: Band Gw1, lowest channel

Plot 1: Unmodulated carrier reference (with pilot-tone)

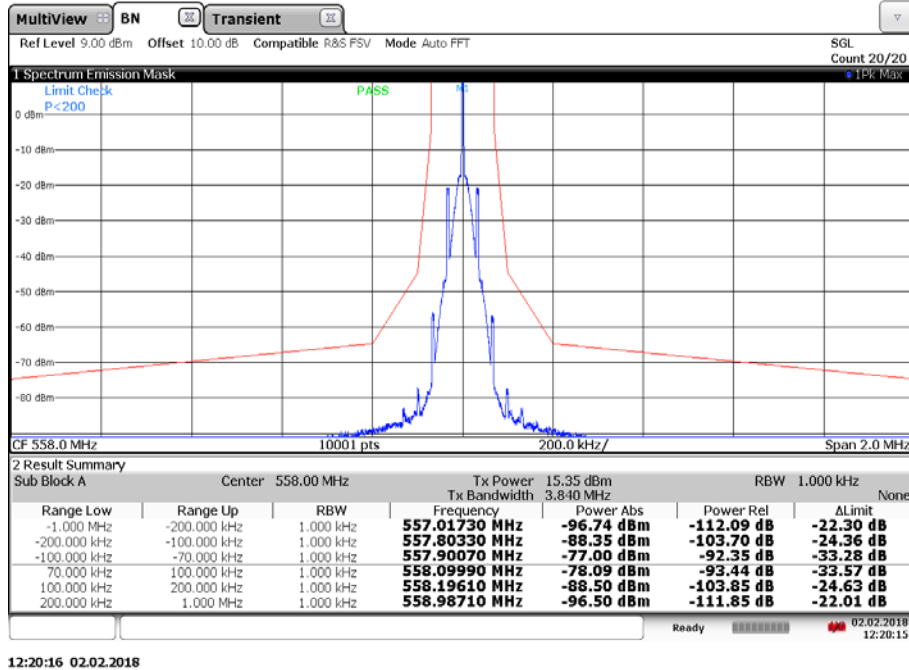

Plot 2: Modulated carrier with the weighted noise source

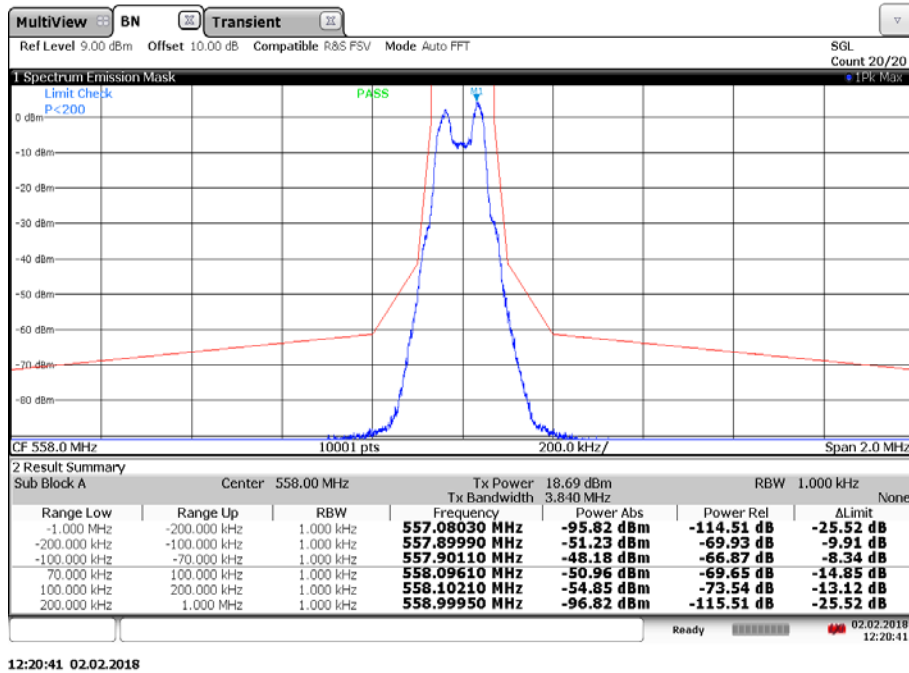

Plots: Band Gw1, middle channel

Plot 1: Unmodulated carrier reference (with pilot-tone)

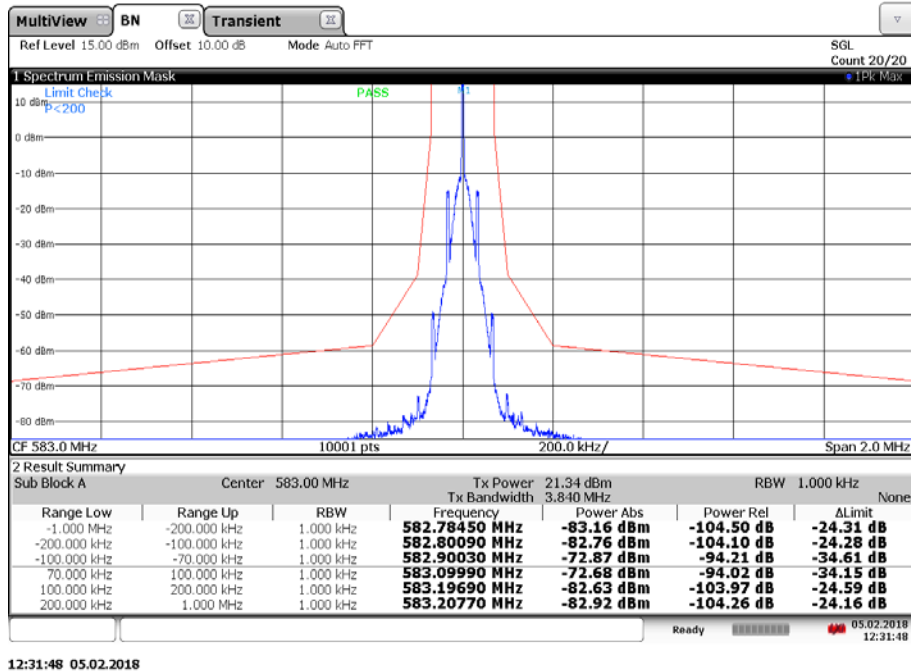

Plot 2: Modulated carrier with the weighted noise source

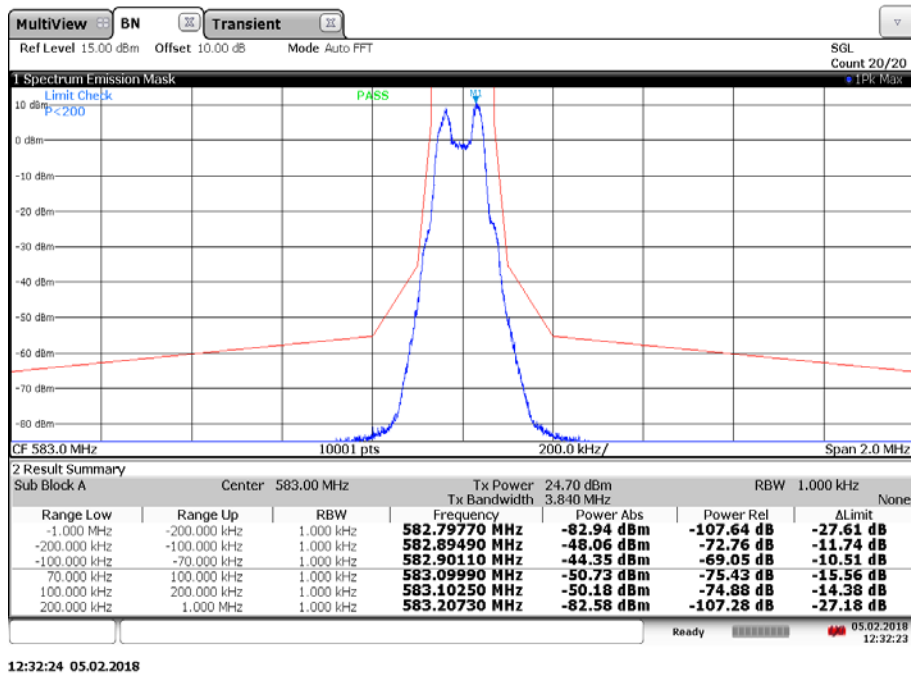

Plots: Band Gw1, highest channel

Plot 1: Unmodulated carrier reference (with pilot-tone)

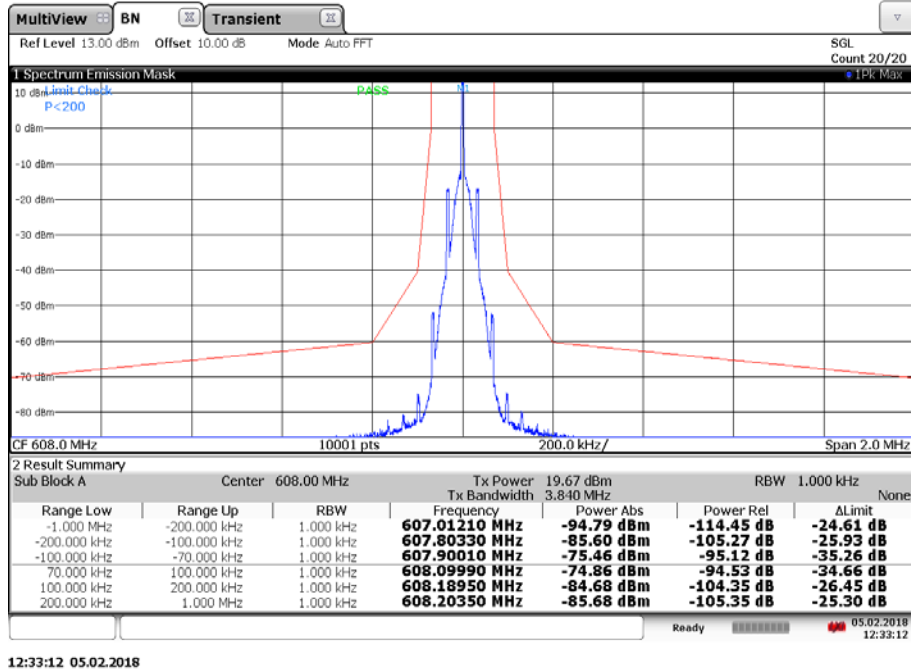

Plot 2: Modulated carrier with the weighted noise source

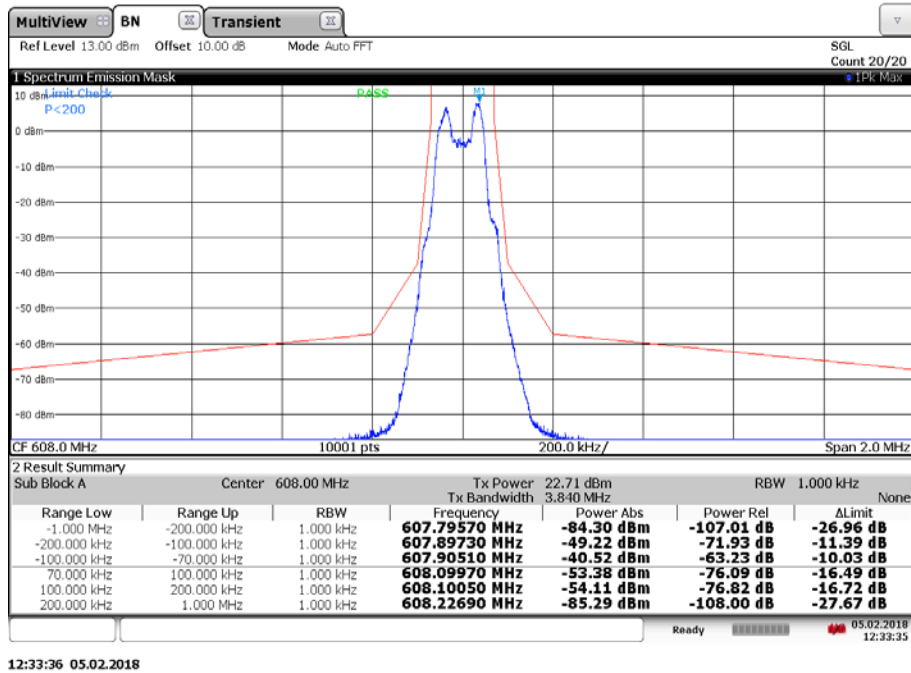

11.7 Frequency modulation

Measurement:

Measurement parameter	
Detector:	Peak
Sweep time:	Auto
Resolution bandwidth:	1 % to 5 % of the occupied bandwidth
Video bandwidth:	3 x resolution bandwidth
Span:	2 x emission bandwidth
Trace mode:	Max. hold
Analyzer function:	99% power occupied bandwidth function
EUT:	Modulated signal with frequency varied between 50 Hz and 15 kHz
Test setup:	See sub clause 6.2 - B
Measurement uncertainty:	See sub clause 9

Limits:

FCC & IC
Frequency deviation up to a maximum of ± 75 kHz

Plots: Band Aw+ (Included Band A1)

Plot 1: lowest channel, max hold with frequency variation from 50 Hz to 15 kHz

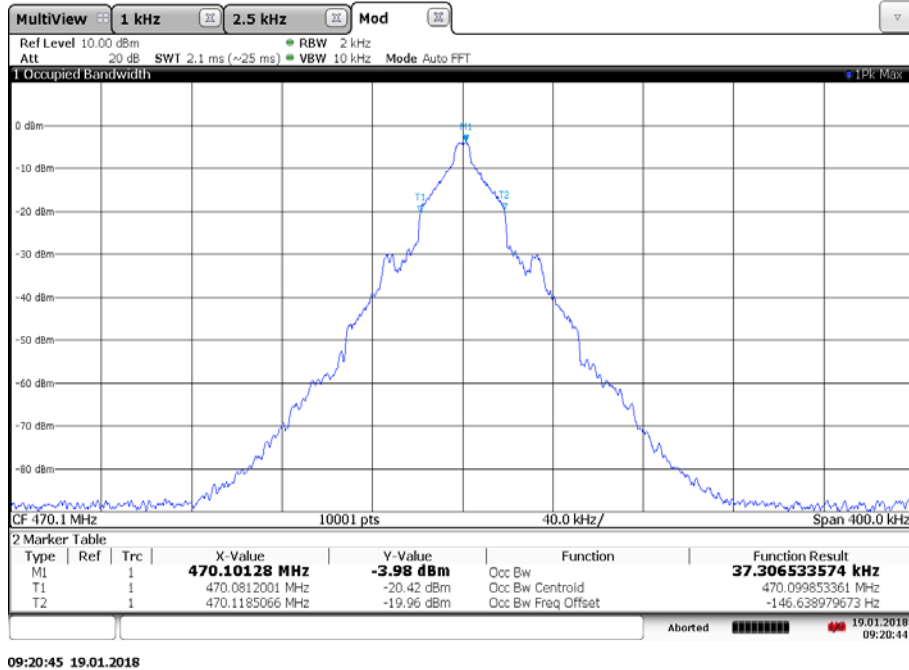

Plot 2: middle channel, max hold with frequency variation from 50 Hz to 15 kHz

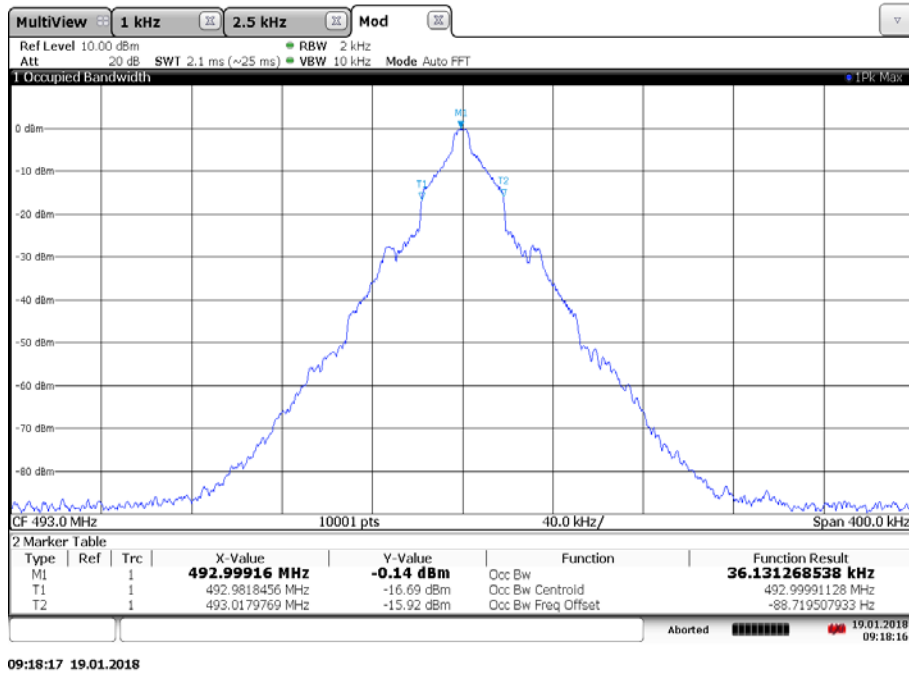

Plot 3: highest channel, max hold with frequency variation from 50 Hz to 15 kHz

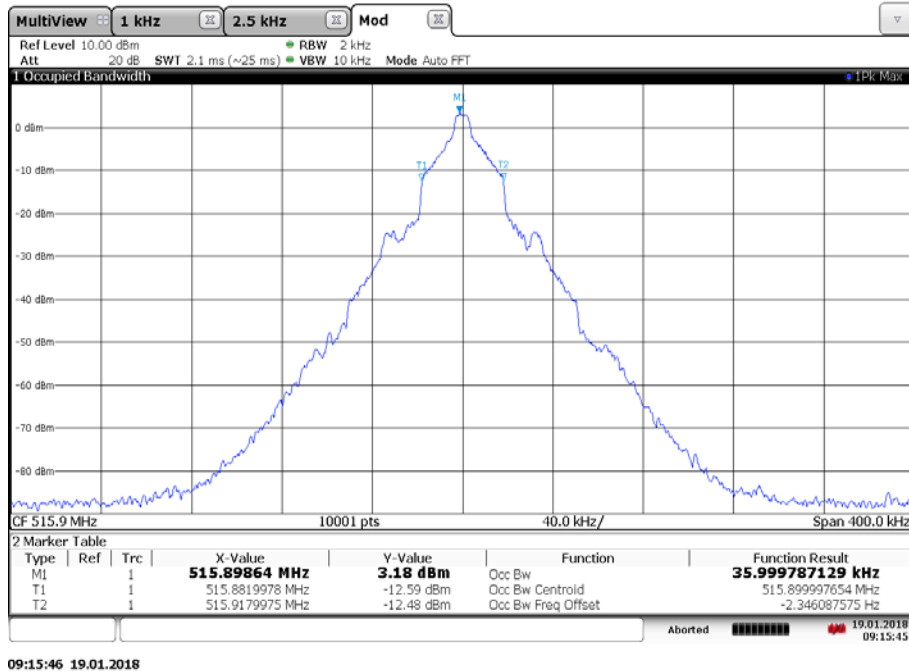

Plots: Band Aw+ (Included Band A)

Plot 1: lowest channel, max hold with frequency variation from 50 Hz to 15 kHz

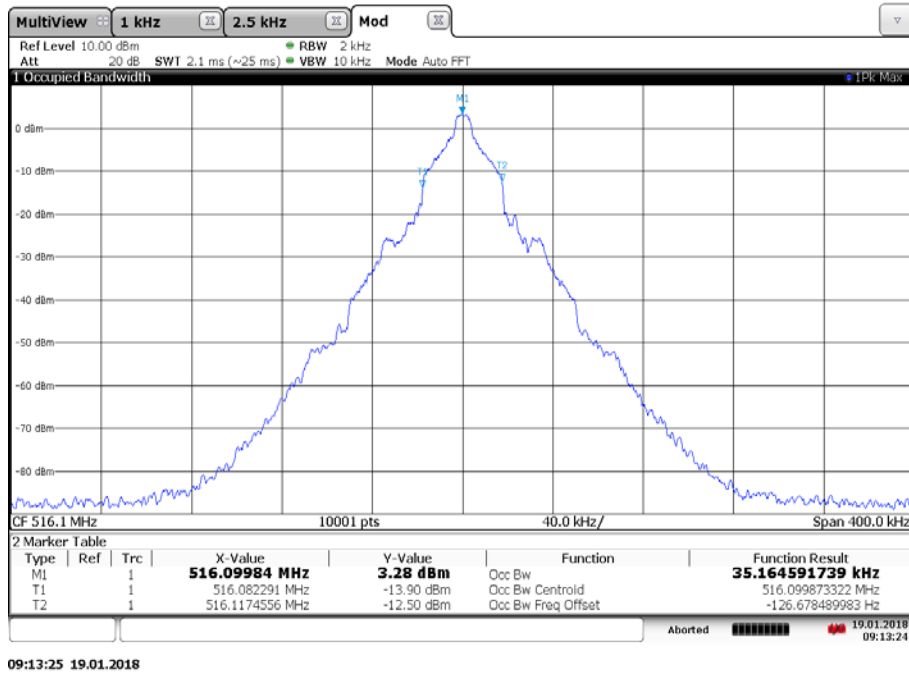

Plot 2: middle channel, max hold with frequency variation from 50 Hz to 15 kHz

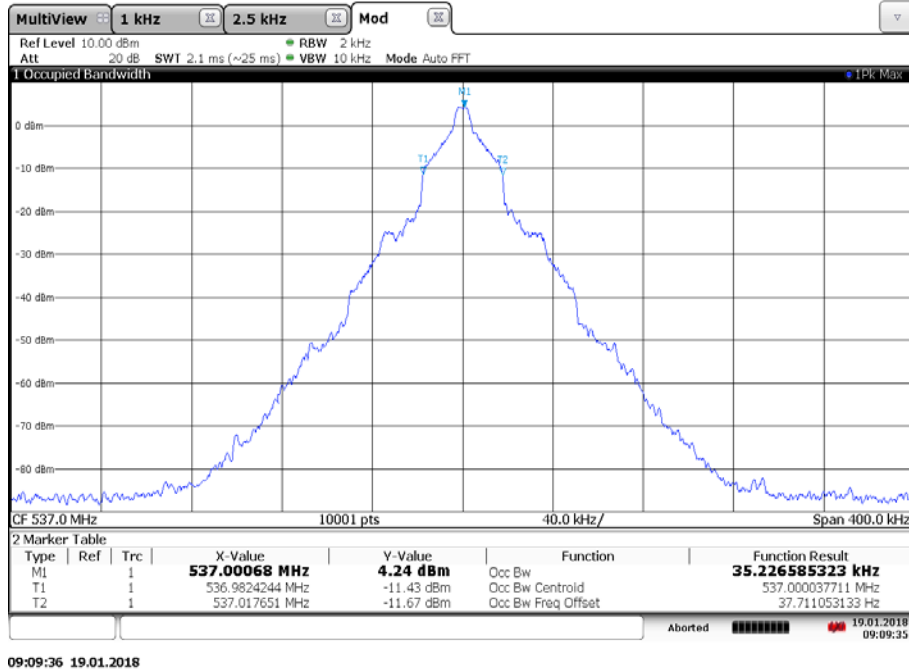

Plot 3: highest channel, max hold with frequency variation from 50 Hz to 15 kHz

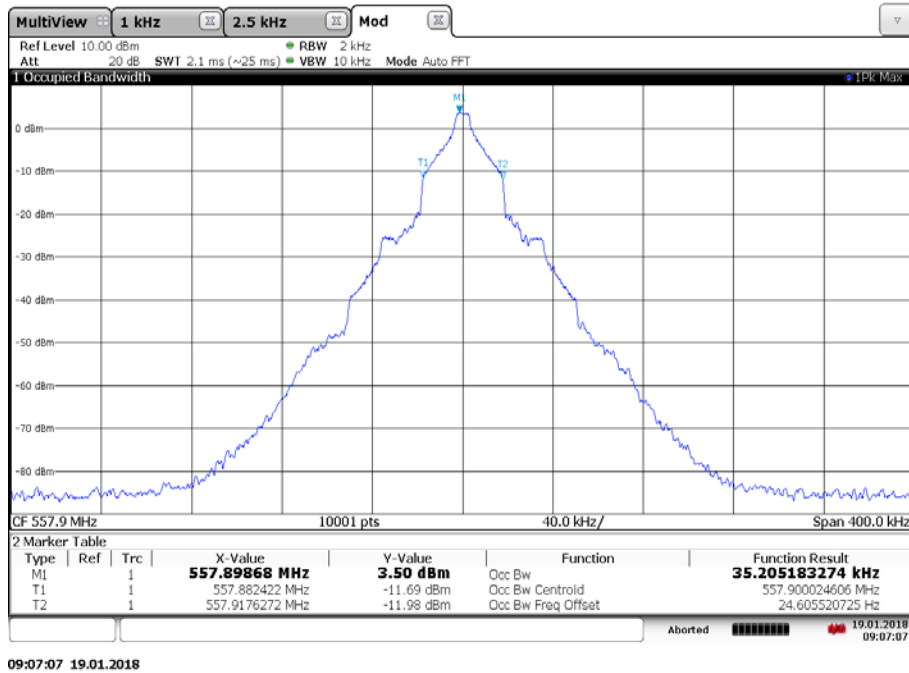

Plots: Band Gw1

Plot 1: lowest channel, max hold with frequency variation from 50 Hz to 15 kHz

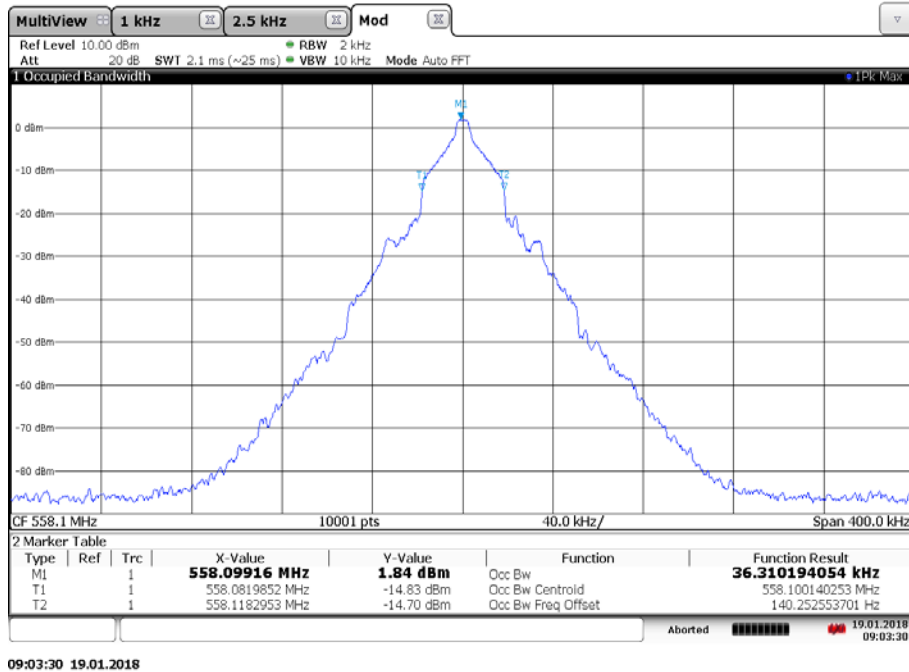

Plot 2: middle channel, max hold with frequency variation from 50 Hz to 15 kHz

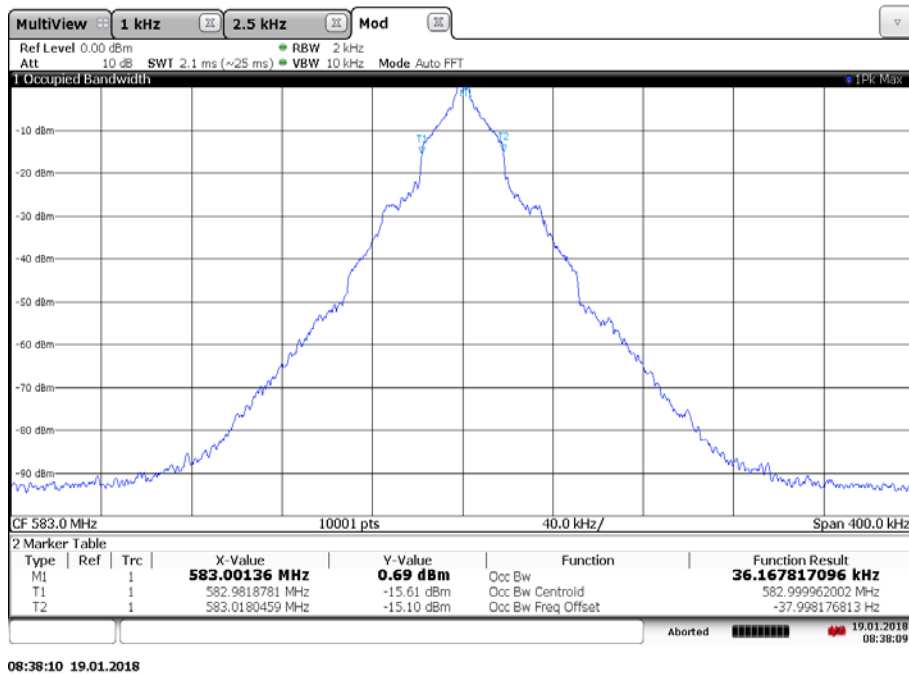

Plot 3: highest channel, max hold with frequency variation from 50 Hz to 15 kHz

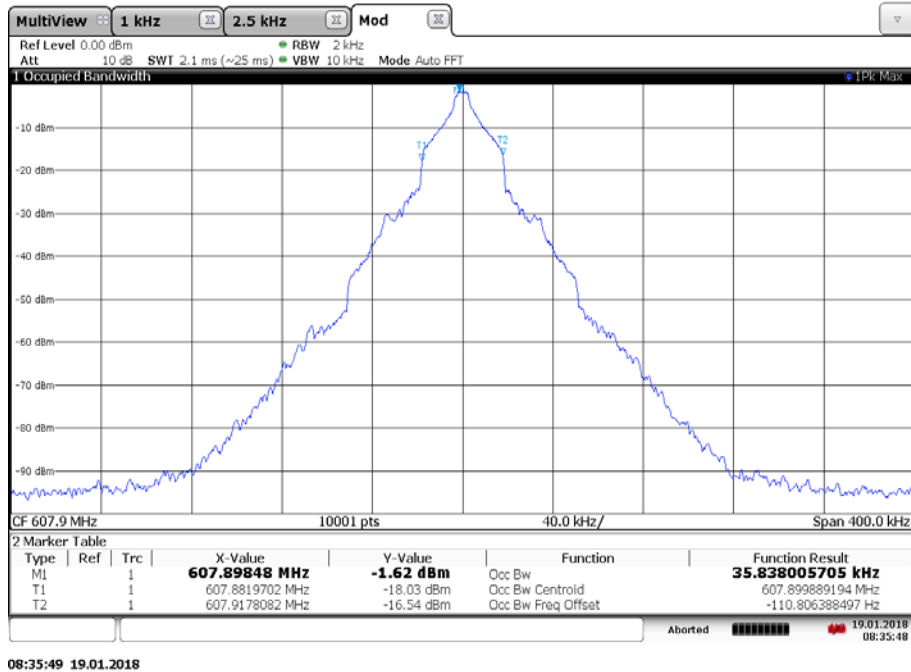

12 Observations

No observations except those reported with the single test cases have been made.

Annex A Glossary

EUT	Equipment under test
DUT	Device under test
UUT	Unit under test
GUE	GNSS User Equipment
ETSI	European Telecommunications Standards Institute
EN	European Standard
FCC	Federal Communications Commission
FCC ID	Company Identifier at FCC
IC	Industry Canada
PMN	Product marketing name
HMN	Host marketing name
HVIN	Hardware version identification number
FVIN	Firmware version identification number
EMC	Electromagnetic Compatibility
HW	Hardware
SW	Software
Inv. No.	Inventory number
S/N or SN	Serial number
C	Compliant
NC	Not compliant
NA	Not applicable
NP	Not performed
PP	Positive peak
QP	Quasi peak
AVG	Average
OC	Operating channel
OCW	Operating channel bandwidth
OBW	Occupied bandwidth
OOB	Out of band
DFS	Dynamic frequency selection
CAC	Channel availability check
OP	Occupancy period
NOP	Non occupancy period
DC	Duty cycle
PER	Packet error rate
CW	Clean wave
MC	Modulated carrier
WLAN	Wireless local area network
RLAN	Radio local area network
DSSS	Dynamic sequence spread spectrum
OFDM	Orthogonal frequency division multiplexing
FHSS	Frequency hopping spread spectrum
GNSS	Global Navigation Satellite System
C/N₀	Carrier to noise-density ratio, expressed in dB-Hz

Annex B Document history

Version	Applied changes	Date of release
-/-	Initial release	2018-03-20

Annex C Accreditation Certificate

first page	last page
 <p>DAkKS Deutsche Akkreditierungsstelle</p> <p>Deutsche Akkreditierungsstelle GmbH</p> <p>Entrusted according to Section 8 subsection 1 AkkStelleG in connection with Section 1 subsection 1 AkkStelleGBV Signatory to the Multilateral Agreements of EA, ILAC and IAF for Mutual Recognition</p> <p>Accreditation</p> <p>The Deutsche Akkreditierungsstelle GmbH attests that the testing laboratory CTC advanced GmbH Untertürkheimer Straße 6-10, 66117 Saarbrücken</p> <p>is competent under the terms of DIN EN ISO/IEC 17025:2005 to carry out tests in the following fields: Telecommunication</p> <p>The accreditation certificate shall only apply in connection with the notice of accreditation of 02.06.2017 with the accreditation number D-PL-12076-01 and is valid until 21.04.2021. It comprises the cover sheet, the reverse side of the cover sheet and the following annex with a total of 43 pages.</p> <p>Registration number of the certificate: D-PL-12076-01-03</p> <p>Frankfurt, 02.06.2017</p> <p>Dipl.-Ing. (FH) Ralf Böker Head of Division</p>	 <p>Deutsche Akkreditierungsstelle GmbH</p> <p>Office Berlin Spittelmarkt 10 10117 Berlin</p> <p>Office Frankfurt am Main Europa-Allee 52 60327 Frankfurt am Main</p> <p>Office Braunschweig Bundesallee 100 38116 Braunschweig</p> <p>The publication of extracts of the accreditation certificate is subject to the prior written approval by Deutsche Akkreditierungsstelle GmbH (DAKKS). Exempted is the unchanged form of separate disseminations of the cover sheet by the conformity assessment body mentioned overleaf.</p> <p>No impression shall be made that the accreditation also extends to fields beyond the scope of accreditation attested by DAKKS.</p> <p>The accreditation was granted pursuant to the Act on the Accreditation Body (AkkStelleG) of 31 July 2009 (Federal Law Gazette I p. 2625) and the Regulation (EC) No 765/2008 of the European Parliament and of the Council of 9 July 2008 setting out the requirements for accreditation and market surveillance relating to the marketing of products (Official Journal of the European Union L 218 of 9 July 2008, p. 30). DAKKS is a signatory to the Multilateral Agreements for Mutual Recognition of the European co-operation for Accreditation (EA), International Accreditation Forum (IAF) and International Laboratory Accreditation Cooperation (ILAC). The signatories to these agreements recognise each other's accreditations.</p> <p>The up-to-date state of membership can be retrieved from the following websites: EA: www.european-accreditation.org ILAC: www.ilac.org IAF: www.iaf.nu</p>

Note: The current certificate annex is published on the website (link see below) of the Accreditation Body DAkKS or may be received by CTC advanced GmbH on request

<http://www.dakks.de/as/ast/d/D-PL-12076-01-03.pdf>