



FCC TEST REPORT

REPORT NO.: RF120928C03
MODEL NO.: PRESENCE
FCC ID: DMOCBMSKE
RECEIVED: Sep. 28, 2012
TESTED: Oct. 15, 2012 ~ Jan. 08, 2013
ISSUED: Jan. 09, 2013

APPLICANT: Sennheiser Electronic Corp (NY)

ADDRESS: 1 Enterprise Drive Old Lyme, Connecticut 06371
United States

ISSUED BY: Bureau Veritas Consumer Products Services
(H.K.) Ltd., Taoyuan Branch

LAB ADDRESS: No. 47, 14th Ling, Chia Pau Vil., Lin Kou Dist.,
New Taipei City, Taiwan, R.O.C.

TEST LOCATION: No. 19, Hwa Ya 2nd Rd, Wen Hwa Tsuen, Kwei
Shan Hsiang, Taoyuan Hsien 333, Taiwan, R.O.C.

This report should not be used by the client to claim product certification, approval, or endorsement by TAF or any government agencies.



This report is for your exclusive use. Any copying or replication of this report to or for any other person or entity, or use of our name or trademark, is permitted only with our prior written permission. This report sets forth our findings solely with respect to the test samples identified herein. The results set forth in this report are not indicative or representative of the quality or characteristics of the lot from which a test sample was taken or any similar or identical product unless specifically and expressly noted. Our report includes all of the tests requested by you and the results thereof based upon the information that you provided to us. You have 60 days from date of issuance of this report to notify us of any material error or omission caused by our negligence, provided, however, that such notice shall be in writing and shall specifically address the issue you wish to raise. A failure to raise such issue within the prescribed time shall constitute your unqualified acceptance of the completeness of this report, the tests conducted and the correctness of the report contents. Unless specific mention, the uncertainty of measurement has been explicitly taken into account to declare the compliance or non-compliance to the specification

Table of Contents

| | |
|--|----|
| RELEASE CONTROL RECORD | 6 |
| 1. CERTIFICATION..... | 7 |
| 2. SUMMARY OF TEST RESULTS | 8 |
| 2.1 MEASUREMENT UNCERTAINTY | 9 |
| 3. GENERAL INFORMATION..... | 10 |
| 3.1 GENERAL DESCRIPTION OF EUT | 10 |
| 3.2 DESCRIPTION OF TEST MODES..... | 11 |
| 3.2.1 TEST MODE APPLICABILITY AND TESTED CHANNEL DETAIL..... | 12 |
| 3.3 DESCRIPTION OF SUPPORT UNITS | 16 |
| 3.3.1 CONFIGURATION OF SYSTEM UNDER TEST | 16 |
| 3.4 GENERAL DESCRIPTION OF APPLIED STANDARDS | 18 |
| 4. TEST TYPES AND RESULTS (FOR BLUETOOTH EDR)..... | 19 |
| 4.1 RADIATED EMISSION AND BANDEDGE MEASUREMENT..... | 19 |
| 4.1.1 LIMITS OF RADIATED EMISSION AND BANDEDGE MEASUREMENT | 19 |
| 4.1.2 TEST INSTRUMENTS | 20 |
| 4.1.3 TEST PROCEDURES | 21 |
| 4.1.4 DEVIATION FROM TEST STANDARD | 21 |
| 4.1.5 TEST SETUP | 22 |
| 4.1.6 EUT OPERATING CONDITIONS | 22 |
| 4.1.7 TEST RESULTS | 23 |
| 4.2 CONDUCTED EMISSION MEASUREMENT | 33 |
| 4.2.1 LIMITS OF CONDUCTED EMISSION MEASUREMENT..... | 33 |
| 4.2.2 TEST INSTRUMENTS | 33 |
| 4.2.3 TEST PROCEDURES | 34 |
| 4.2.4 DEVIATION FROM TEST STANDARD | 34 |
| 4.2.5 TEST SETUP | 35 |
| 4.2.6 EUT OPERATING CONDITIONS | 35 |
| 4.2.7 TEST RESULTS | 36 |
| 4.3 NUMBER OF HOPPING FREQUENCY USED..... | 40 |
| 4.3.1 LIMIT OF HOPPING FREQUENCY USED | 40 |
| 4.3.2 TEST SETUP | 40 |
| 4.3.3 TEST INSTRUMENTS | 40 |
| 4.3.4 TEST PROCEDURES | 40 |
| 4.3.5 DEVIATION FROM TEST STANDARD | 40 |
| 4.3.6 TEST RESULTS | 40 |
| 4.4 DWELL TIME ON EACH CHANNEL | 42 |
| 4.4.1 LIMIT OF DWELL TIME USED..... | 42 |
| 4.4.2 TEST SETUP | 42 |



| | | |
|-------|--|----|
| 4.4.3 | TEST INSTRUMENTS | 42 |
| 4.4.4 | TEST PROCEDURES | 42 |
| 4.4.5 | DEVIATION FROM TEST STANDARD | 42 |
| 4.4.6 | TEST RESULTS | 43 |
| 4.5 | CHANNEL BANDWIDTH..... | 45 |
| 4.5.1 | LIMITS OF CHANNEL BANDWIDTH | 45 |
| 4.5.2 | TEST SETUP | 45 |
| 4.5.3 | TEST INSTRUMENTS | 45 |
| 4.5.4 | TEST PROCEDURE | 45 |
| 4.5.5 | DEVIATION FROM TEST STANDARD | 45 |
| 4.5.6 | EUT OPERATING CONDITION | 45 |
| 4.5.7 | TEST RESULTS | 46 |
| 4.6 | HOPPING CHANNEL SEPARATION | 47 |
| 4.6.1 | LIMIT OF HOPPING CHANNEL SEPARATION | 47 |
| 4.6.2 | TEST SETUP | 47 |
| 4.6.3 | TEST INSTRUMENTS | 47 |
| 4.6.4 | TEST PROCEDURES | 47 |
| 4.6.5 | DEVIATION FROM TEST STANDARD | 47 |
| 4.6.6 | TEST RESULTS | 48 |
| 4.7 | MAXIMUM OUTPUT POWER..... | 49 |
| 4.7.1 | LIMITS OF MAXIMUM OUTPUT POWER MEASUREMENT | 49 |
| 4.7.2 | TEST SETUP | 49 |
| 4.7.3 | TEST INSTRUMENTS | 49 |
| 4.7.4 | TEST PROCEDURES | 49 |
| 4.7.5 | DEVIATION FROM TEST STANDARD | 49 |
| 4.7.6 | EUT OPERATING CONDITION | 49 |
| 4.7.7 | TEST RESULTS | 50 |
| 4.8 | CONDUCTED OUT OF BAND EMISSION MEASUREMENT..... | 51 |
| 4.8.1 | LIMITS OF CONDUCTED OUT OF BAND EMISSION MEASUREMENT | 51 |
| 4.8.2 | TEST INSTRUMENTS | 51 |
| 4.8.3 | TEST PROCEDURE | 51 |
| 4.8.4 | DEVIATION FROM TEST STANDARD | 51 |
| 4.8.5 | EUT OPERATING CONDITION | 51 |
| 4.8.6 | TEST RESULTS | 51 |
| 5. | TEST TYPES AND RESULTS (FOR BLUETOOTH LE 4.0)..... | 54 |
| 5.1 | RADIATED EMISSION AND BANDEDGE MEASUREMENT..... | 54 |
| 5.1.1 | LIMITS OF RADIATED EMISSION AND BANDEDGE MEASUREMENT | 54 |
| 5.1.2 | TEST INSTRUMENTS | 54 |
| 5.1.3 | TEST PROCEDURES | 54 |
| 5.1.4 | DEVIATION FROM TEST STANDARD | 54 |
| 5.1.5 | TEST SETUP | 54 |
| 5.1.6 | EUT OPERATING CONDITIONS..... | 54 |



| | | |
|-------|--|----|
| 5.1.7 | TEST RESULTS | 55 |
| 5.2 | CONDUCTED EMISSION MEASUREMENT | 62 |
| 5.2.1 | LIMITS OF CONDUCTED EMISSION MEASUREMENT | 62 |
| 5.2.2 | TEST INSTRUMENTS | 62 |
| 5.2.3 | TEST PROCEDURES | 62 |
| 5.2.4 | DEVIATION FROM TEST STANDARD | 62 |
| 5.2.5 | TEST SETUP | 62 |
| 5.2.6 | EUT OPERATING CONDITIONS | 62 |
| 5.2.7 | TEST RESULTS | 63 |
| 5.3 | 6dB BANDWIDTH MEASUREMENT | 67 |
| 5.3.1 | LIMITS OF 6dB BANDWIDTH MEASUREMENT | 67 |
| 5.3.2 | TEST SETUP | 67 |
| 5.3.3 | TEST INSTRUMENTS | 67 |
| 5.3.4 | TEST PROCEDURE | 67 |
| 5.3.5 | DEVIATION FROM TEST STANDARD | 67 |
| 5.3.6 | EUT OPERATING CONDITIONS | 67 |
| 5.3.7 | TEST RESULTS | 68 |
| 5.4 | CONDUCTED OUTPUT POWER | 69 |
| 5.4.1 | LIMITS OF CONDUCTED OUTPUT POWER MEASUREMENT | 69 |
| 5.4.2 | TEST SETUP | 69 |
| 5.4.3 | TEST INSTRUMENTS | 69 |
| 5.4.4 | TEST PROCEDURES | 69 |
| 5.4.5 | DEVIATION FROM TEST STANDARD | 69 |
| 5.4.6 | EUT OPERATING CONDITIONS | 69 |
| 5.4.7 | TEST RESULTS | 69 |
| 5.5 | POWER SPECTRAL DENSITY MEASUREMENT | 70 |
| 5.5.1 | LIMITS OF POWER SPECTRAL DENSITY MEASUREMENT | 70 |
| 5.5.2 | TEST SETUP | 70 |
| 5.5.3 | TEST INSTRUMENTS | 70 |
| 5.5.4 | TEST PROCEDURE | 70 |
| 5.5.5 | DEVIATION FROM TEST STANDARD | 70 |
| 5.5.6 | EUT OPERATING CONDITION | 70 |
| 5.5.7 | TEST RESULTS | 70 |
| 5.6 | CONDUCTED OUT OF BAND EMISSION MEASUREMENT | 71 |
| 5.6.1 | LIMITS OF OUT OF BAND EMISSION MEASUREMENT | 71 |
| 5.6.2 | TEST SETUP | 71 |
| 5.6.3 | TEST INSTRUMENTS | 71 |
| 5.6.4 | TEST PROCEDURE | 71 |
| 5.6.5 | DEVIATION FROM TEST STANDARD | 72 |
| 5.6.6 | EUT OPERATING CONDITION | 72 |
| 5.6.7 | TEST RESULTS | 72 |
| 5.6.8 | TEST RESULTS | 73 |



A D T

| | | |
|----|--|----|
| 6. | PHOTOGRAPHS OF THE TEST CONFIGURATION..... | 74 |
| 7. | INFORMATION ON THE TESTING LABORATORIES | 75 |
| 8. | APPENDIX A – MODIFICATIONS RECORDERS FOR ENGINEERING CHANGES TO THE EUT BY THE LAB..... | 76 |

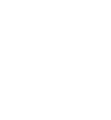



A D T

RELEASE CONTROL RECORD

| ISSUE NO. | REASON FOR CHANGE | DATE ISSUED |
|-------------|-------------------|---------------|
| RF120928C03 | Original release. | Jan. 09, 2013 |



1. CERTIFICATION

PRODUCT: Bluetooth mono headset
MODEL NO.: PRESENCE
BRAND: SENNHEISER
APPLICANT: Sennheiser Electronic Corp (NY)
TESTED: Oct. 15, 2012 ~ Jan. 08, 2013
TEST SAMPLE: ENGINEERING SAMPLE
STANDARDS: **FCC Part 15, Subpart C (Section 15.247)**
ANSI C63.10-2009

The above equipment (model: PRESENCE) has been tested by **Bureau Veritas Consumer Products Services (H.K.) Ltd., Taoyuan Branch**, and found compliance with the requirement of the above standards. The test record, data evaluation & Equipment Under Test (EUT) configurations represented herein are true and accurate accounts of the measurements of the sample's EMC characteristics under the conditions specified in this report.

PREPARED BY : Suntee Liu , DATE : Jan. 09, 2013
Suntee Liu / Specialist

APPROVED BY : Ken Liu , DATE : Jan. 09, 2013
Ken Liu / Manager

2. SUMMARY OF TEST RESULTS

The EUT has been tested according to the following specifications:

| APPLIED STANDARD: FCC Part 15, Subpart C (Bluetooth EDR) | | | |
|--|---|--------|---|
| STANDARD SECTION | TEST TYPE AND LIMIT | RESULT | REMARK |
| 15.207 | AC Power Conducted Emission | PASS | Meet the requirement of limit. Minimum passing margin is -7.04dB at 0.49324MHz. |
| 15.247(a)(1) (iii) | Number of Hopping Frequency Used | PASS | Meet the requirement of limit. |
| 15.247(a)(1) (iii) | Dwell Time on Each Channel | PASS | Meet the requirement of limit. |
| 15.247(a)(1) | 1. Hopping Channel Separation 2. Spectrum Bandwidth of a Frequency Hopping Sequence Spread Spectrum System | PASS | Meet the requirement of limit. |
| 15.247(b) | Maximum Peak Output Power | PASS | Meet the requirement of limit. |
| 15.247(d) | Transmitter Radiated Emissions | PASS | Meet the requirement of limit. Minimum passing margin is -3.0dB at 31.35MHz. |
| 15.247(d) | Band Edge Measurement | PASS | Meet the requirement of limit. |
| 15.203 | Antenna Requirement | PASS | No antenna connector is used. |

NOTE: If The Frequency Hopping System operating in 2400-2483.5MHz band and the output power less than 125mW. The hopping channel carrier frequencies separated by a minimum of 25kHz or two-thirds of the 20dB bandwidth of hopping channel whichever is greater.

| APPLIED STANDARD: FCC PART 15, SUBPART C (SECTION 15.247) (Bluetooth LE 4.0) | | | |
|--|-----------------------------|--------|---|
| STANDARD SECTION | TEST TYPE AND LIMIT | RESULT | REMARK |
| 15.207 | AC Power Conducted Emission | PASS | Meet the requirement of limit. Minimum passing margin is -6.57dB at 0.49324MHz. |
| 15.247(d) 15.209 | Radiated Emissions | PASS | Meet the requirement of limit. Minimum passing margin is -1.1dB at 7320.00MHz. |
| 15.247(d) | Band Edge Measurement | PASS | Meet the requirement of limit. |
| 15.247(a)(2) | 6dB bandwidth | PASS | Meet the requirement of limit. |
| 15.247(b) | Conducted power | PASS | Meet the requirement of limit. |
| 15.247(e) | Power Spectral Density | PASS | Meet the requirement of limit. |
| 15.203 | Antenna Requirement | PASS | No antenna connector is used. |

2.1 MEASUREMENT UNCERTAINTY

Where relevant, the following measurement uncertainty levels have been estimated for tests performed on the EUT as specified in CISPR 16-4-2:

| MEASUREMENT | FREQUENCY | UNCERTAINTY |
|---------------------|-----------------|-------------|
| Conducted emissions | 9kHz~30MHz | 2.44 dB |
| Radiated emissions | 30MHz ~ 200MHz | 2.93 dB |
| | 200MHz ~1000MHz | 2.95 dB |
| | 1GHz ~ 18GHz | 2.26 dB |
| | 18GHz ~ 40GHz | 1.94 dB |

This uncertainty represents an expanded uncertainty expressed at approximately the 95% confidence level using a coverage factor of k=2.

3. GENERAL INFORMATION

3.1 GENERAL DESCRIPTION OF EUT

| | | |
|----------------------------|--|-----------------------------|
| EUT | Bluetooth mono headset | |
| MODEL NO. | PRESENCE | |
| POWER SUPPLY | 5Vdc (adapter / host equipment / car charger) 3.7Vdc (Li-ion battery) | |
| MODULATION TYPE | Bluetooth EDR | GFSK, $\pi/4$ -DQPSK, 8DPSK |
| | Bluetooth LE 4.0 | GFSK |
| TRANSFER RATE | Bluetooth EDR | 1/2/3Mbps |
| | Bluetooth LE 4.0 | 3Mbps |
| OPERATING FREQUENCY | 2402~2480MHz | |
| NUMBER OF CHANNEL | Bluetooth EDR | 79 |
| | Bluetooth LE 4.0 | 40 |
| CHANNEL SPACING | Bluetooth EDR | 1MHz |
| | Bluetooth LE 4.0 | 2MHz |
| OUTPUT POWER | Bluetooth EDR | 6.653mW |
| | Bluetooth LE 4.0 | 4.819mW |
| ANTENNA TYPE | Printed antenna with 1.7dBi gain | |
| ANTENNA CONNECTOR | N/A | |
| DATA CABLE | 0.1m non-shielded USB cable without core 1m non-shielded USB cable without core | |
| I/O PORTS | Refer to user's manual | |
| ACCESSORY DEVICES | Adapter, Car charger | |

NOTE:

- The EUT is powered by the following adapter.

| | |
|---------------------|---------------------------|
| Brand | SIL Switching Adapter |
| Model | SSA-3P 050015US |
| Input Power | 100-240Vac, 50/60Hz, 0.2A |
| Output Power | 5.0Vdc, 150mA |

- The EUT is powered by the following car charger.

| | |
|---------------------|---------------|
| Model | SIL-C05050A |
| Input Power | 12-24dc, 0.5A |
| Output Power | 5Vdc, 500mA |

- The above EUT information is declared by the manufacturer and for more detailed features description, please refer to the manufacturer's specifications or User's Manual.

3.2 DESCRIPTION OF TEST MODES

Bluetooth EDR:

79 channels are provided to this EUT:

| CHANNEL | FREQ. (MHz) | CHANNEL | FREQ. (MHz) | CHANNEL | FREQ. (MHz) | CHANNEL | FREQ. (MHz) |
|---------|-------------|---------|-------------|---------|-------------|---------|-------------|
| 0 | 2402 | 20 | 2422 | 40 | 2442 | 60 | 2462 |
| 1 | 2403 | 21 | 2423 | 41 | 2443 | 61 | 2463 |
| 2 | 2404 | 22 | 2424 | 42 | 2444 | 62 | 2464 |
| 3 | 2405 | 23 | 2425 | 43 | 2445 | 63 | 2465 |
| 4 | 2406 | 24 | 2426 | 44 | 2446 | 64 | 2466 |
| 5 | 2407 | 25 | 2427 | 45 | 2447 | 65 | 2467 |
| 6 | 2408 | 26 | 2428 | 46 | 2448 | 66 | 2468 |
| 7 | 2409 | 27 | 2429 | 47 | 2449 | 67 | 2469 |
| 8 | 2410 | 28 | 2430 | 48 | 2450 | 68 | 2470 |
| 9 | 2411 | 29 | 2431 | 49 | 2451 | 69 | 2471 |
| 10 | 2412 | 30 | 2432 | 50 | 2452 | 70 | 2472 |
| 11 | 2413 | 31 | 2433 | 51 | 2453 | 71 | 2473 |
| 12 | 2414 | 32 | 2434 | 52 | 2454 | 72 | 2474 |
| 13 | 2415 | 33 | 2435 | 53 | 2455 | 73 | 2475 |
| 14 | 2416 | 34 | 2436 | 54 | 2456 | 74 | 2476 |
| 15 | 2417 | 35 | 2437 | 55 | 2457 | 75 | 2477 |
| 16 | 2418 | 36 | 2438 | 56 | 2458 | 76 | 2478 |
| 17 | 2419 | 37 | 2439 | 57 | 2459 | 77 | 2479 |
| 18 | 2420 | 38 | 2440 | 58 | 2460 | 78 | 2480 |
| 19 | 2421 | 39 | 2441 | 59 | 2461 | | |

Bluetooth LE 4.0:

40 channels are provided to this EUT:

| CHANNEL | FREQ. (MHz) | CHANNEL | FREQ. (MHz) | CHANNEL | FREQ. (MHz) | CHANNEL | FREQ. (MHz) |
|---------|-------------|---------|-------------|---------|-------------|---------|-------------|
| 0 | 2402 | 10 | 2422 | 20 | 2442 | 30 | 2462 |
| 1 | 2404 | 11 | 2424 | 21 | 2444 | 31 | 2464 |
| 2 | 2406 | 12 | 2426 | 22 | 2446 | 32 | 2466 |
| 3 | 2408 | 13 | 2428 | 23 | 2448 | 33 | 2468 |
| 4 | 2410 | 14 | 2430 | 24 | 2450 | 34 | 2470 |
| 5 | 2412 | 15 | 2432 | 25 | 2452 | 35 | 2472 |
| 6 | 2414 | 16 | 2434 | 26 | 2454 | 36 | 2474 |
| 7 | 2416 | 17 | 2436 | 27 | 2456 | 37 | 2476 |
| 8 | 2418 | 18 | 2438 | 28 | 2458 | 38 | 2478 |
| 9 | 2420 | 19 | 2440 | 29 | 2460 | 39 | 2480 |

3.2.1 TEST MODE APPLICABILITY AND TESTED CHANNEL DETAIL

Bluetooth EDR:

| EUT CONFIGURE MODE | APPLICABLE TO | | | | DESCRIPTION |
|--------------------|---------------|-----------|-----|------|-------------------------------|
| | RE \geq 1G | RE $<$ 1G | PLC | APCM | |
| A | √ | √ | √ | √ | EUT power from adapter |
| B | - | √ | √ | - | EUT power from host equipment |
| C | - | √ | - | - | EUT power from Li-ion battery |
| D | - | √ | - | - | EUT power from car charger |

Where **RE \geq 1G**: Radiated Emission above 1GHz **RE $<$ 1G**: Radiated Emission below 1GHz
PLC: Power Line Conducted Emission **APCM**: Antenna Port Conducted Measurement

NOTE: The EUT had been pre-tested on the positioned of each 3 axis. The worst case was found when positioned on Y-plane.

RADIATED EMISSION TEST (ABOVE 1 GHz):

- Pre-Scan has been conducted to determine the worst-case mode from all possible combinations between available modulations, antenna ports (if EUT with antenna diversity architecture) and packet type.
- Following channel(s) was (were) selected for the final test as listed below.

| EUT CONFIGURE MODE | AVAILABLE CHANNEL | TESTED CHANNEL | MODULATION TYPE | PACKET TYPE |
|--------------------|-------------------|----------------|-----------------|-------------|
| A | 0 to 78 | 0, 39, 78 | GFSK | DH5 |
| A | 0 to 78 | 0, 39, 78 | 8DPSK | DH5 |

RADIATED EMISSION TEST (BELOW 1 GHz):

- Pre-Scan has been conducted to determine the worst-case mode from all possible combinations between available modulations, antenna ports (if EUT with antenna diversity architecture) and packet type.
- Following channel(s) was (were) selected for the final test as listed below.

| EUT CONFIGURE MODE | AVAILABLE CHANNEL | TESTED CHANNEL | MODULATION TYPE | PACKET TYPE |
|--------------------|-------------------|----------------|-----------------|-------------|
| A, B, C, D | 0 to 78 | 0 | GFSK | DH5 |

POWER LINE CONDUCTED EMISSION TEST:

- Pre-Scan has been conducted to determine the worst-case mode from all possible combinations between available modulations, antenna ports (if EUT with antenna diversity architecture), and packet types.
- Following channel(s) was (were) selected for the final test as listed below.

| EUT CONFIGURE MODE | AVAILABLE CHANNEL | TESTED CHANNEL | MODULATION TYPE | PACKET TYPE |
|--------------------|-------------------|----------------|-----------------|-------------|
| A, B | 0 to 78 | 0 | GFSK | DH5 |

ANTENNA PORT CONDUCTED MEASUREMENT:

- This item includes all test value of each mode, but only includes spectrum plot of worst value of each mode.
- Pre-Scan has been conducted to determine the worst-case mode from all possible combinations between available modulations, antenna ports (if EUT with antenna diversity architecture), and packet types.
- Following channel(s) was (were) selected for the final test as listed below.

| EUT CONFIGUURE MODE | AVAILABLE CHANNEL | TESTED CHANNEL | MODULATION TYPE | PACKET TYPE |
|---------------------|-------------------|----------------|-----------------|-------------|
| A | 0 to 78 | 0, 39, 78 | GFSK | DH5 |
| A | 0 to 78 | 0, 39, 78 | 8DPSK | DH5 |

TEST CONDITION:

| APPLICABLE TO | ENVIRONMENTAL CONDITIONS | INPUT POWER | TESTED BY |
|---------------|--------------------------|------------------------|------------|
| RE \geq 1G | 24deg. C, 67%RH | 120Vac, 60Hz | Martin Lee |
| RE $<$ 1G | 24deg. C, 67%RH | 120Vac, 60Hz 3.7Vdc | Martin Lee |
| PLC | 26deg. C, 65%RH | 120Vac, 60Hz | Cedric Wu |
| APCM | 24deg. C, 64%RH | 120Vac, 60Hz | Match Tsui |

FOR Bluetooth LE 4.0:

| EUT CONFIGUURE MODE | APPLICABLE TO | | | | DESCRIPTION |
|---------------------|---------------|-------|-----|------|-------------------------------|
| | RE≥1G | RE<1G | PLC | APCM | |
| A | √ | √ | √ | √ | EUT power from adapter |
| B | - | √ | √ | - | EUT power from host equipment |
| C | - | √ | - | - | EUT power from Li-ion battery |
| D | - | √ | - | - | EUT power from car charger |

Where **RE≥1G**: Radiated Emission above 1GHz **RE<1G**: Radiated Emission below 1GHz
PLC: Power Line Conducted Emission **APCM**: Antenna Port Conducted Measurement

NOTE: The EUT had been pre-tested on the positioned of each 3 axis. The worst case was found when positioned on Y-plane.

RADIATED EMISSION TEST (ABOVE 1GHz):

- Pre-Scan has been conducted to determine the worst-case mode from all possible combinations between available modulations and antenna ports (if EUT with antenna diversity architecture).
- Following channel(s) was (were) selected for the final test as listed below.

| EUT CONFIGUURE MODE | AVAILABLE CHANNEL | TESTED CHANNEL | MODULATION TYPE | DATA RATE (Mbps) |
|---------------------|-------------------|----------------|-----------------|------------------|
| A | 0 to 39 | 0, 19, 39 | GFSK | 3 |

RADIATED EMISSION TEST (BELOW 1GHz):

- Pre-Scan has been conducted to determine the worst-case mode from all possible combinations between available modulations and antenna ports (if EUT with antenna diversity architecture).
- Following channel(s) was (were) selected for the final test as listed below.

| EUT CONFIGUURE MODE | AVAILABLE CHANNEL | TESTED CHANNEL | MODULATION TYPE | DATA RATE (Mbps) |
|---------------------|-------------------|----------------|-----------------|------------------|
| A, B, C, D | 0 to 39 | 0 | GFSK | 3 |

POWER LINE CONDUCTED EMISSION TEST:

- Pre-Scan has been conducted to determine the worst-case mode from all possible combinations between available modulations and antenna ports (if EUT with antenna diversity architecture).
- Following channel(s) was (were) selected for the final test as listed below.

| EUT CONFIGUURE MODE | AVAILABLE CHANNEL | TESTED CHANNEL | MODULATION TYPE | DATA RATE (Mbps) |
|---------------------|-------------------|----------------|-----------------|------------------|
| A, B | 0 to 39 | 0 | GFSK | 3 |

ANTENNA PORT CONDUCTED MEASUREMENT:

- Pre-Scan has been conducted to determine the worst-case mode from all possible combinations between available modulations, data rates and antenna ports (if EUT with antenna diversity architecture).
- Following channel(s) was (were) selected for the final test as listed below.

| EUT CONFIGUURE MODE | AVAILABLE CHANNEL | TESTED CHANNEL | MODULATION TYPE | DATA RATE (Mbps) |
|---------------------|-------------------|----------------|-----------------|------------------|
| A | 0 to 39 | 0, 19, 39 | GFSK | 3 |

TEST CONDITION:

| APPLICABLE TO | ENVIRONMENTAL CONDITIONS | INPUT POWER | TESTED BY |
|---------------|--------------------------|------------------------|------------|
| RE≥1G | 24deg. C, 67%RH | 120Vac, 60Hz | Martin Lee |
| RE<1G | 25deg. C, 65%RH | 120Vac, 60Hz 3.7Vdc | Chris Lin |
| PLC | 26deg. C, 65%RH | 120Vac, 60Hz | Cedric Wu |
| APCM | 24deg. C, 64%RH | 120Vac, 60Hz | Match Tsui |

3.3 DESCRIPTION OF SUPPORT UNITS

The EUT has been tested as an independent unit together with other necessary accessories or support units. The following support units or accessories were used to form a representative test configuration during the tests.

| NO. | PRODUCT | BRAND | MODEL NO. | SERIAL NO. | FCC ID |
|-----|-----------------|-------|------------|------------------------------|--------------|
| 1 | Notebook | DELL | D531 | CN-0XM006-48643-8 1U-2610 | QDS-BRCM1020 |
| 2 | DC Power Supply | R&S | NGSM 32/10 | 4237 | NA |

| NO. | SIGNAL CABLE DESCRIPTION OF THE ABOVE SUPPORT UNITS |
|-----|---|
| 1 | NA |
| 2 | NA |

NOTE: All power cords of the above support units are non-shielded (1.8m).

3.3.1 CONFIGURATION OF SYSTEM UNDER TEST

TEST MODE A

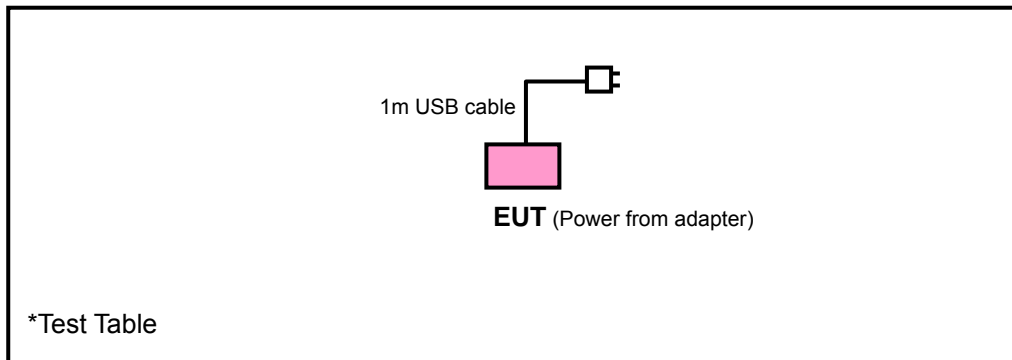

TEST MODE B

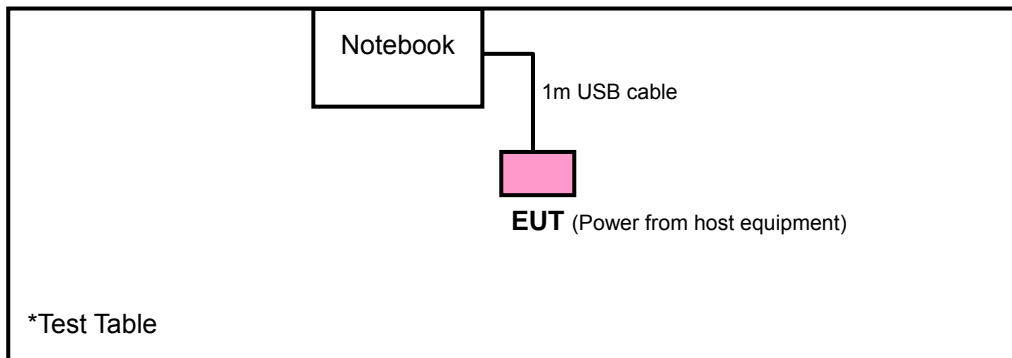

TEST MODE C

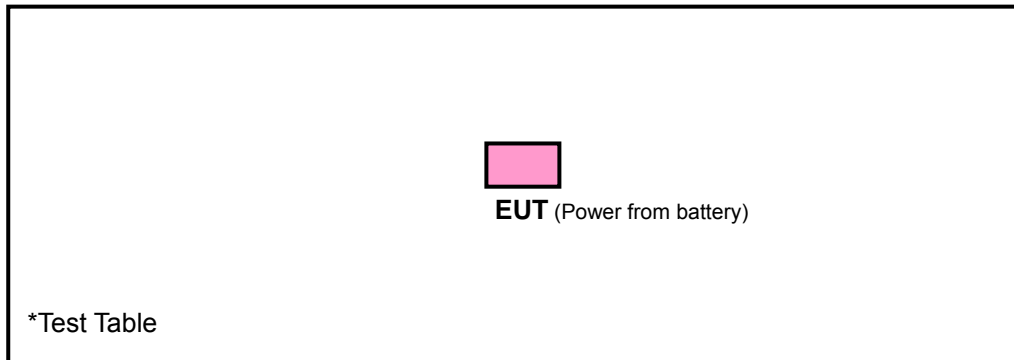

TEST MODE D

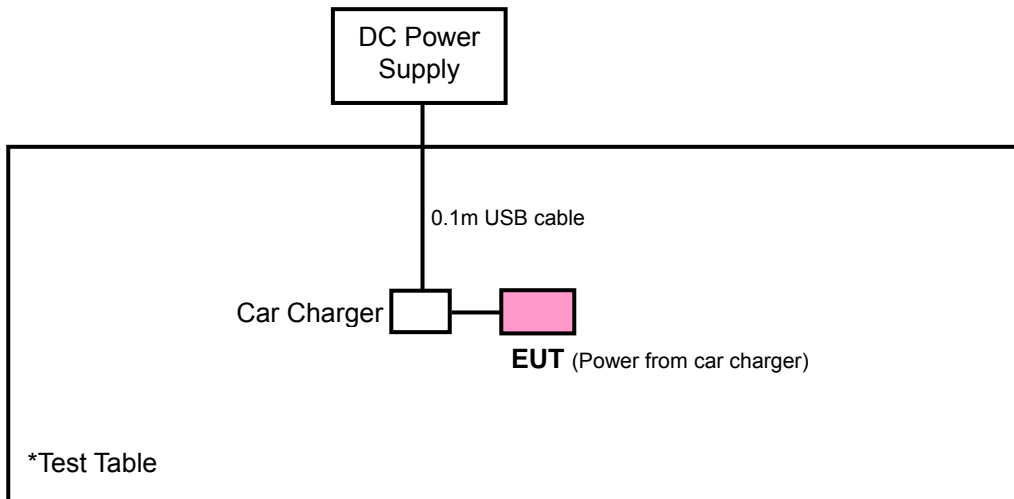



3.4 GENERAL DESCRIPTION OF APPLIED STANDARDS

The EUT is a RF Product. According to the specifications of the manufacturer, it must comply with the requirements of the following standards:

FCC Part 15, Subpart C (15.247)
558074 D01 DTS Meas Guidance v02
FCC Public Notice DA 00-705
ANSI C63.10-2009

All test items have been performed and recorded as per the above standards.

4. TEST TYPES AND RESULTS (FOR BLUETOOTH EDR)

4.1 RADIATED EMISSION AND BANDEDGE MEASUREMENT

4.1.1 LIMITS OF RADIATED EMISSION AND BANDEDGE MEASUREMENT

Radiated emissions which fall in the restricted bands must comply with the radiated emission limits specified as below table. Other emissions shall be at least 20dB below the highest level of the desired power:

| FREQUENCIES (MHz) | FIELD STRENGTH (microvolts/meter) | MEASUREMENT DISTANCE (meters) |
|-------------------|-----------------------------------|-------------------------------|
| 0.009 ~ 0.490 | 2400/F(kHz) | 300 |
| 0.490 ~ 1.705 | 24000/F(kHz) | 30 |
| 1.705 ~ 30.0 | 30 | 30 |
| 30 ~ 88 | 100 | 3 |
| 88 ~ 216 | 150 | 3 |
| 216 ~ 960 | 200 | 3 |
| Above 960 | 500 | 3 |

NOTE:

1. The lower limit shall apply at the transition frequencies.
2. Emission level (dBuV/m) = 20 log Emission level (uV/m).
3. For frequencies above 1000MHz, the field strength limits are based on average detector, however, the peak field strength of any emission shall not exceed the maximum permitted average limits, specified above by more than 20dB under any condition of modulation.

4.1.2 TEST INSTRUMENTS

| DESCRIPTION & MANUFACTURER | MODEL NO. | SERIAL NO. | DATE OF CALIBRATION | DUE DATE OF CALIBRATION |
|---|------------------------------|------------------|---------------------|-------------------------|
| Test Receiver ROHDE & SCHWARZ | ESIB7 | 100212 | Aug. 06, 2012 | Aug. 05, 2013 |
| Spectrum Analyzer ROHDE & SCHWARZ | FSP40 | 100039 | Feb. 03, 2012 | Feb. 02, 2013 |
| BILOG Antenna SCHWARZBECK | VULB9168 | 9168-160 | Apr. 06, 2012 | Apr. 05, 2013 |
| HORN Antenna SCHWARZBECK | 9120D | 209 | Sep. 03, 2012 | Sep. 02, 2013 |
| HORN Antenna SCHWARZBECK | BBHA 9170 | 148 | Jul. 11, 2012 | Jul. 10, 2013 |
| Loop Antenna | HFH2-Z2 | 100070 | Jan. 31, 2012 | Jan. 30, 2014 |
| Preamplifier Agilent | 8447D | 2944A10633 | Oct. 25, 2012 | Oct. 24, 2013 |
| Preamplifier Agilent | 8449B | 3008A01964 | Oct. 25, 2012 | Oct. 24, 2013 |
| RF signal cable HUBER+SUHNNER | SUCOFLEX 104 | 250723/4 | Aug. 28, 2012 | Aug. 27, 2013 |
| RF signal cable HUBER+SUHNNER | SUCOFLEX 106 | 12738/6+309224/4 | Aug. 28, 2012 | Aug. 27, 2013 |
| Software ADT. | ADT_Radiated_ V7.6.15.9.2 | NA | NA | NA |
| Antenna Tower inn-co GmbH | MA 4000 | 013303 | NA | NA |
| Antenna Tower Controller inn-co GmbH | CO2000 | 017303 | NA | NA |
| Turn Table ADT. | TT100 | TT93021703 | NA | NA |
| Turn Table Controller ADT. | SC100 | SC93021703 | NA | NA |
| High Speed Peak Power Meter | ML2495A | 0842014 | Apr. 28, 2012 | Apr. 27, 2013 |
| Power Sensor | MA2411B | 0738404 | Apr. 28, 2012 | Apr. 27, 2013 |

- NOTE:**
1. The calibration interval of the above test instruments is 12 months and the calibrations are traceable to NML/ROC and NIST/USA.
 2. The calibration interval of the loop antenna is 24 months and the calibrations are traceable to NML/ROC and NIST/USA.
 3. The test was performed in HwaYa Chamber 3.
 4. The horn antenna and HP preamplifier (model: 8449B) are used only for the measurement of emission frequency above 1GHz if tested.
 5. The FCC Site Registration No. is 988962.
 6. The IC Site Registration No. is IC 7450F-3.

4.1.3 TEST PROCEDURES

- a. The EUT was placed on the top of a rotating table 0.8 meters above the ground at a 3 meter semi-anechoic chamber. The table was rotated 360 degrees to determine the position of the highest radiation.
- b. The EUT was set 3 meters away from the interference-receiving antenna, which was mounted on the top of a variable-height antenna tower.
- c. The antenna is a broadband antenna, and its height is varied from one meter to four meters above the ground to determine the maximum value of the field strength. Both horizontal and vertical polarizations of the antenna are set to make the measurement.
- d. For each suspected emission, the EUT was arranged to its worst case and then the antenna was tuned to heights from 1 meter to 4 meters and the rotatable table was turned from 0 degrees to 360 degrees to find the maximum reading.
- e. The test-receiver system was set to Peak Detect Function and Specified Bandwidth with Maximum Hold Mode.
- f. If the emission level of the EUT in peak mode was lower than the limit specified, then testing could be stopped and the peak values of the EUT would be reported. Otherwise the emissions would be re-tested one by one using peak, quasi-peak or average method as specified and then reported in a data sheet.

NOTE:

1. The resolution bandwidth and video bandwidth of test receiver/spectrum analyzer is 120kHz for Quasi-peak detection at frequency below 1GHz.
2. The resolution bandwidth of test receiver/spectrum analyzer is 1 MHz and video bandwidth is 3MHz for Peak detection at frequency above 1GHz.
3. All modes of operation were investigated and the worst-case emissions are reported.

4.1.4 DEVIATION FROM TEST STANDARD

No deviation.

4.1.5 TEST SETUP

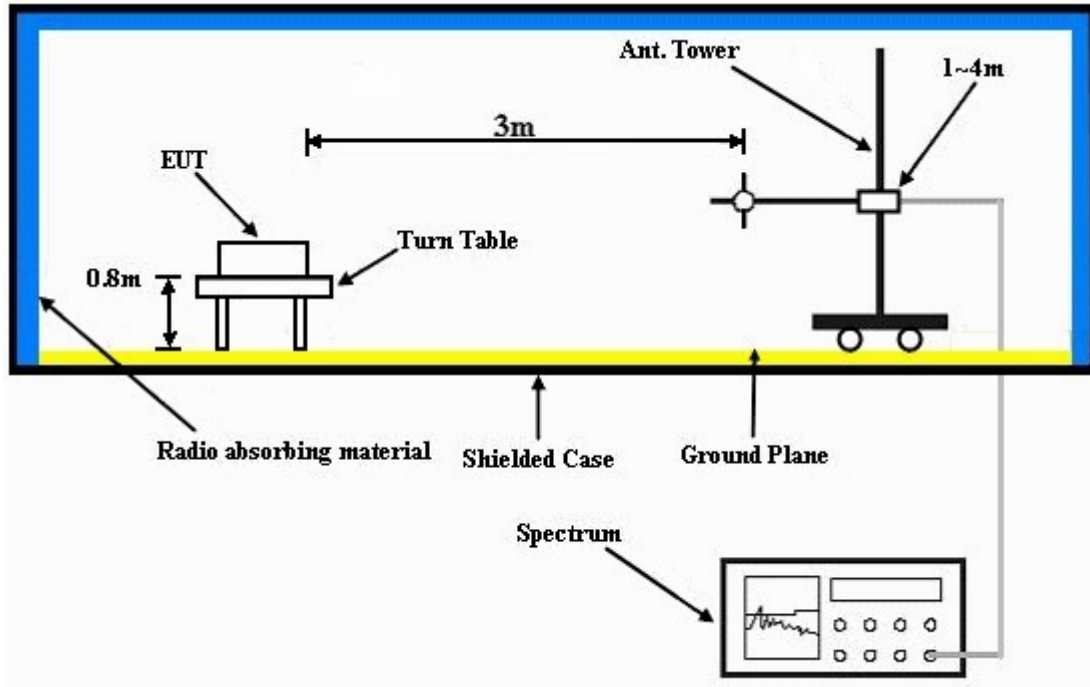

For the actual test configuration, please refer to the attached file (Test Setup Photo).

4.1.6 EUT OPERATING CONDITIONS

TEST MODE A, C, D

- a. Placed the EUT on the testing table.
- b. Set the EUT under transmission condition continuously at specific channel frequency.

TEST MODE B

- a. Connected the EUT with notebook via USB cable on the testing table.
- b. Set the EUT under transmission condition continuously at specific channel frequency.

4.1.7 TEST RESULTS

ABOVE 1GHz WORST-CASE DATA :

GFSK

| EUT TEST CONDITION | | MEASUREMENT DETAIL | |
|--------------------------|-----------------|--------------------|---------------------------|
| CHANNEL | Channel 0 | FREQUENCY RANGE | 1 ~ 25GHz |
| INPUT POWER | 120Vac, 60Hz | DETECTOR FUNCTION | Peak (PK) Average (AV) |
| ENVIRONMENTAL CONDITIONS | 24deg. C, 67%RH | TESTED BY | Martin Lee |

| ANTENNA POLARITY & TEST DISTANCE: HORIZONTAL AT 3 M | | | | | | | | |
|---|-------------|-------------------------|----------------|-------------|--------------------|----------------------|------------------|--------------------------|
| NO. | FREQ. (MHz) | EMISSION LEVEL (dBuV/m) | LIMIT (dBuV/m) | MARGIN (dB) | ANTENNA HEIGHT (m) | TABLE ANGLE (Degree) | RAW VALUE (dBuV) | CORRECTION FACTOR (dB/m) |
| 1 | 2390.00 | 41.5 PK | 74.0 | -32.5 | 1.09 H | 214 | 10.70 | 30.80 |
| 2 | 2390.00 | 30.1 AV | 54.0 | -23.9 | 1.09 H | 214 | -0.70 | 30.80 |
| 3 | #2400.00 | 64.6 PK | 83.6 | -19.0 | 1.09 H | 186 | 33.70 | 30.90 |
| 4 | #2400.00 | 34.5 AV | 53.5 | -19.0 | 1.09 H | 186 | 3.60 | 30.90 |
| 5 | *2402.00 | 103.6 PK | | | 1.09 H | 186 | 72.70 | 30.90 |
| 6 | *2402.00 | 73.5 AV | | | 1.09 H | 186 | 42.60 | 30.90 |
| 7 | 4804.00 | 61.4 PK | 74.0 | -12.6 | 1.03 H | 121 | 24.50 | 36.90 |
| 8 | 4804.00 | 31.3 AV | 54.0 | -22.7 | 1.03 H | 121 | -5.60 | 36.90 |
| ANTENNA POLARITY & TEST DISTANCE: VERTICAL AT 3 M | | | | | | | | |
| NO. | FREQ. (MHz) | EMISSION LEVEL (dBuV/m) | LIMIT (dBuV/m) | MARGIN (dB) | ANTENNA HEIGHT (m) | TABLE ANGLE (Degree) | RAW VALUE (dBuV) | CORRECTION FACTOR (dB/m) |
| 1 | 2390.00 | 39.8 PK | 74.0 | -34.2 | 1.22 V | 45 | 9.00 | 30.80 |
| 2 | 2390.00 | 30.1 AV | 54.0 | -23.9 | 1.22 V | 45 | -0.70 | 30.80 |
| 3 | #2400.00 | 59.0 PK | 78.0 | -19.0 | 1.02 V | 196 | 28.10 | 30.90 |
| 4 | #2400.00 | 28.9 AV | 47.9 | -19.0 | 1.02 V | 196 | -2.00 | 30.90 |
| 5 | *2402.00 | 98.0 PK | | | 1.02 V | 196 | 67.10 | 30.90 |
| 6 | *2402.00 | 67.9 AV | | | 1.02 V | 196 | 37.00 | 30.90 |
| 7 | 4804.00 | 58.5 PK | 74.0 | -15.5 | 1.00 V | 163 | 21.60 | 36.90 |
| 8 | 4804.00 | 28.4 AV | 54.0 | -25.6 | 1.00 V | 163 | -8.50 | 36.90 |

REMARKS:

1. Emission level (dBuV/m) = Raw Value (dBuV) + Correction Factor (dB/m).
2. Correction Factor (dB/m) = Antenna Factor (dB/m) + Cable Factor (dB).
3. The other emission levels were very low against the limit.
4. Margin value = Emission level – Limit value.
5. “ * “: Fundamental frequency.
6. The DH5 packet was the worse case duty cycle for a transmit dwell time on a channel, based upon bluetooth theory the transmitter is on 0.625 * 5 per 296.25 ms per channel. Therefore, the duty cycle correlation factor be equal to: $20\log(3.125 / 100) = -30.1$ dB.
7. Average value = peak reading + $20\log(\text{duty cycle})$.
8. "#": The radiated frequency is out the restricted band.

| EUT TEST CONDITION | | MEASUREMENT DETAIL | |
|--------------------------|-----------------|--------------------|---------------------------|
| CHANNEL | Channel 39 | FREQUENCY RANGE | 1 ~ 25GHz |
| INPUT POWER | 120Vac, 60Hz | DETECTOR FUNCTION | Peak (PK) Average (AV) |
| ENVIRONMENTAL CONDITIONS | 24deg. C, 67%RH | TESTED BY | Martin Lee |

| ANTENNA POLARITY & TEST DISTANCE: HORIZONTAL AT 3 M | | | | | | | | |
|---|-------------|-------------------------|----------------|-------------|--------------------|----------------------|------------------|--------------------------|
| NO. | FREQ. (MHz) | EMISSION LEVEL (dBuV/m) | LIMIT (dBuV/m) | MARGIN (dB) | ANTENNA HEIGHT (m) | TABLE ANGLE (Degree) | RAW VALUE (dBuV) | CORRECTION FACTOR (dB/m) |
| 1 | *2441.00 | 106.2 PK | | | 1.06 H | 138 | 75.20 | 31.00 |
| 2 | *2441.00 | 76.1 AV | | | 1.06 H | 138 | 45.10 | 31.00 |
| 3 | 4882.00 | 51.4 PK | 74.0 | -22.6 | 1.24 H | 148 | 14.30 | 37.10 |
| 4 | 4882.00 | 21.3 AV | 54.0 | -32.7 | 1.24 H | 148 | -15.80 | 37.10 |
| ANTENNA POLARITY & TEST DISTANCE: VERTICAL AT 3 M | | | | | | | | |
| NO. | FREQ. (MHz) | EMISSION LEVEL (dBuV/m) | LIMIT (dBuV/m) | MARGIN (dB) | ANTENNA HEIGHT (m) | TABLE ANGLE (Degree) | RAW VALUE (dBuV) | CORRECTION FACTOR (dB/m) |
| 1 | *2441.00 | 98.2 PK | | | 1.63 V | 141 | 67.20 | 31.00 |
| 2 | *2441.00 | 68.1 AV | | | 1.63 V | 141 | 37.10 | 31.00 |
| 3 | 4882.00 | 48.2 PK | 74.0 | -25.8 | 1.00 V | 156 | 11.10 | 37.10 |
| 4 | 4882.00 | 18.1 AV | 54.0 | -35.9 | 1.00 V | 156 | -19.00 | 37.10 |

REMARKS:

1. Emission level (dBuV/m) = Raw Value (dBuV) + Correction Factor (dB/m).
2. Correction Factor (dB/m) = Antenna Factor (dB/m) + Cable Factor (dB).
3. The other emission levels were very low against the limit.
4. Margin value = Emission level – Limit value.
5. “ * “: Fundamental frequency.
6. The DH5 packet was the worse case duty cycle for a transmit dwell time on a channel, based upon bluetooth theory the transmitter is on 0.625 * 5 per 296.25 ms per channel. Therefore, the duty cycle correlation factor be equal to: $20\log(3.125 / 100) = -30.1$ dB.
7. Average value = peak reading + $20\log(\text{duty cycle})$.

| EUT TEST CONDITION | | MEASUREMENT DETAIL | |
|--------------------------|-----------------|--------------------|---------------------------|
| CHANNEL | Channel 78 | FREQUENCY RANGE | 1 ~ 25GHz |
| INPUT POWER | 120Vac, 60Hz | DETECTOR FUNCTION | Peak (PK) Average (AV) |
| ENVIRONMENTAL CONDITIONS | 24deg. C, 67%RH | TESTED BY | Martin Lee |

| ANTENNA POLARITY & TEST DISTANCE: HORIZONTAL AT 3 M | | | | | | | | |
|---|-------------|-------------------------|----------------|-------------|--------------------|----------------------|------------------|--------------------------|
| NO. | FREQ. (MHz) | EMISSION LEVEL (dBuV/m) | LIMIT (dBuV/m) | MARGIN (dB) | ANTENNA HEIGHT (m) | TABLE ANGLE (Degree) | RAW VALUE (dBuV) | CORRECTION FACTOR (dB/m) |
| 1 | *2480.00 | 106.8 PK | | | 1.04 H | 185 | 75.60 | 31.20 |
| 2 | *2480.00 | 76.7 AV | | | 1.04 H | 185 | 45.50 | 31.20 |
| 3 | 2483.50 | 45.9 PK | 74.0 | -28.1 | 1.04 H | 185 | 14.70 | 31.20 |
| 4 | 2483.50 | 15.8 AV | 54.0 | -38.2 | 1.04 H | 185 | -15.40 | 31.20 |
| 5 | 4960.00 | 57.4 PK | 74.0 | -16.6 | 1.07 H | 126 | 20.10 | 37.30 |
| 6 | 4960.00 | 27.3 AV | 54.0 | -26.7 | 1.07 H | 126 | -10.00 | 37.30 |
| ANTENNA POLARITY & TEST DISTANCE: VERTICAL AT 3 M | | | | | | | | |
| NO. | FREQ. (MHz) | EMISSION LEVEL (dBuV/m) | LIMIT (dBuV/m) | MARGIN (dB) | ANTENNA HEIGHT (m) | TABLE ANGLE (Degree) | RAW VALUE (dBuV) | CORRECTION FACTOR (dB/m) |
| 1 | *2480.00 | 100.5 PK | | | 1.16 V | 79 | 69.30 | 31.20 |
| 2 | *2480.00 | 70.4 AV | | | 1.16 V | 79 | 39.20 | 31.20 |
| 3 | 2483.50 | 39.6 PK | 74.0 | -34.4 | 1.16 V | 79 | 8.40 | 31.20 |
| 4 | 2483.50 | 9.5 AV | 54.0 | -44.5 | 1.16 V | 79 | -21.70 | 31.20 |
| 5 | 4960.00 | 56.1 PK | 74.0 | -17.9 | 1.21 V | 148 | 18.80 | 37.30 |
| 6 | 4960.00 | 26.0 AV | 54.0 | -28.0 | 1.21 V | 148 | -11.30 | 37.30 |

REMARKS:

1. Emission level (dBuV/m) = Raw Value (dBuV) + Correction Factor (dB/m).
2. Correction Factor (dB/m) = Antenna Factor (dB/m) + Cable Factor (dB).
3. The other emission levels were very low against the limit.
4. Margin value = Emission level – Limit value.
5. “ * “: Fundamental frequency.
6. The DH5 packet was the worse case duty cycle for a transmit dwell time on a channel, based upon bluetooth theory the transmitter is on 0.625 * 5 per 296.25 ms per channel. Therefore, the duty cycle correlation factor be equal to: $20\log(3.125 / 100) = -30.1$ dB.
7. Average value = peak reading + $20\log(\text{duty cycle})$.

8DPSK

| EUT TEST CONDITION | | MEASUREMENT DETAIL | |
|--------------------------|-----------------|--------------------|---------------------------|
| CHANNEL | Channel 0 | FREQUENCY RANGE | 1 ~ 25GHz |
| INPUT POWER | 120Vac, 60Hz | DETECTOR FUNCTION | Peak (PK) Average (AV) |
| ENVIRONMENTAL CONDITIONS | 24deg. C, 67%RH | TESTED BY | Martin Lee |

| ANTENNA POLARITY & TEST DISTANCE: HORIZONTAL AT 3 M | | | | | | | | |
|---|-------------|-------------------------|----------------|-------------|--------------------|----------------------|------------------|--------------------------|
| NO. | FREQ. (MHz) | EMISSION LEVEL (dBuV/m) | LIMIT (dBuV/m) | MARGIN (dB) | ANTENNA HEIGHT (m) | TABLE ANGLE (Degree) | RAW VALUE (dBuV) | CORRECTION FACTOR (dB/m) |
| 1 | 2390.00 | 47.5 PK | 74.0 | -26.5 | 1.00 H | 102 | 16.70 | 30.80 |
| 2 | 2390.00 | 36.2 AV | 54.0 | -17.8 | 1.00 H | 102 | 5.40 | 30.80 |
| 3 | #2400.00 | 63.2 PK | 82.5 | -19.3 | 1.39 H | 13 | 32.30 | 30.90 |
| 4 | #2400.00 | 33.1 AV | 52.4 | -19.3 | 1.39 H | 13 | 2.20 | 30.90 |
| 5 | *2402.00 | 102.5 PK | | | 1.39 H | 13 | 71.60 | 30.90 |
| 6 | *2402.00 | 72.4 AV | | | 1.39 H | 13 | 41.50 | 30.90 |
| 7 | 4804.00 | 54.3 PK | 74.0 | -19.7 | 1.14 H | 65 | 17.40 | 36.90 |
| 8 | 4804.00 | 24.2 AV | 54.0 | -29.8 | 1.14 H | 65 | -12.70 | 36.90 |
| ANTENNA POLARITY & TEST DISTANCE: VERTICAL AT 3 M | | | | | | | | |
| NO. | FREQ. (MHz) | EMISSION LEVEL (dBuV/m) | LIMIT (dBuV/m) | MARGIN (dB) | ANTENNA HEIGHT (m) | TABLE ANGLE (Degree) | RAW VALUE (dBuV) | CORRECTION FACTOR (dB/m) |
| 1 | 2390.00 | 44.5 PK | 74.0 | -29.5 | 1.01 V | 80 | 13.70 | 30.80 |
| 2 | 2390.00 | 31.6 AV | 54.0 | -22.4 | 1.01 V | 80 | 0.80 | 30.80 |
| 3 | #2400.00 | 59.0 PK | 78.3 | -19.3 | 1.01 V | 88 | 28.10 | 30.90 |
| 4 | #2400.00 | 28.9 AV | 48.2 | -19.3 | 1.01 V | 88 | -2.00 | 30.90 |
| 5 | *2402.00 | 98.3 PK | | | 1.01 V | 80 | 67.40 | 30.90 |
| 6 | *2402.00 | 68.2 AV | | | 1.01 V | 80 | 37.30 | 30.90 |
| 7 | 4804.00 | 56.1 PK | 74.0 | -17.9 | 1.02 V | 151 | 19.20 | 36.90 |
| 8 | 4804.00 | 26.0 AV | 54.0 | -28.0 | 1.02 V | 151 | -10.90 | 36.90 |

REMARKS:

1. Emission level (dBuV/m) = Raw Value (dBuV) + Correction Factor (dB/m).
2. Correction Factor (dB/m) = Antenna Factor (dB/m) + Cable Factor (dB).
3. The other emission levels were very low against the limit.
4. Margin value = Emission level – Limit value.
5. “ * “: Fundamental frequency.
6. The DH5 packet was the worse case duty cycle for a transmit dwell time on a channel, based upon bluetooth theory the transmitter is on 0.625 * 5 per 296.25 ms per channel. Therefore, the duty cycle correlation factor be equal to: $20\log(3.125 / 100) = -30.1$ dB.
7. Average value = peak reading + $20\log(\text{duty cycle})$.
8. "#": The radiated frequency is out the restricted band.

| EUT TEST CONDITION | | MEASUREMENT DETAIL | |
|--------------------------|-----------------|--------------------|---------------------------|
| CHANNEL | Channel 39 | FREQUENCY RANGE | 1 ~ 25GHz |
| INPUT POWER | 120Vac, 60Hz | DETECTOR FUNCTION | Peak (PK) Average (AV) |
| ENVIRONMENTAL CONDITIONS | 24deg. C, 67%RH | TESTED BY | Martin Lee |

| ANTENNA POLARITY & TEST DISTANCE: HORIZONTAL AT 3 M | | | | | | | | |
|---|-------------|-------------------------|----------------|-------------|--------------------|----------------------|------------------|--------------------------|
| NO. | FREQ. (MHz) | EMISSION LEVEL (dBuV/m) | LIMIT (dBuV/m) | MARGIN (dB) | ANTENNA HEIGHT (m) | TABLE ANGLE (Degree) | RAW VALUE (dBuV) | CORRECTION FACTOR (dB/m) |
| 1 | *2441.00 | 104.4 PK | | | 1.36 H | 21 | 73.40 | 31.00 |
| 2 | *2441.00 | 74.3 AV | | | 1.36 H | 21 | 43.30 | 31.00 |
| 3 | 4882.00 | 50.6 PK | 74.0 | -23.4 | 1.28 H | 110 | 13.50 | 37.10 |
| 4 | 4882.00 | 20.5 AV | 54.0 | -33.5 | 1.28 H | 110 | -16.60 | 37.10 |
| ANTENNA POLARITY & TEST DISTANCE: VERTICAL AT 3 M | | | | | | | | |
| NO. | FREQ. (MHz) | EMISSION LEVEL (dBuV/m) | LIMIT (dBuV/m) | MARGIN (dB) | ANTENNA HEIGHT (m) | TABLE ANGLE (Degree) | RAW VALUE (dBuV) | CORRECTION FACTOR (dB/m) |
| 1 | *2441.00 | 97.8 PK | | | 1.18 V | 317 | 66.80 | 31.00 |
| 2 | *2441.00 | 67.7 AV | | | 1.18 V | 317 | 36.70 | 31.00 |
| 3 | 4882.00 | 51.9 PK | 74.0 | -22.1 | 1.14 V | 145 | 14.80 | 37.10 |
| 4 | 4882.00 | 21.8 AV | 54.0 | -32.2 | 1.14 V | 145 | -15.30 | 37.10 |

REMARKS:

1. Emission level (dBuV/m) = Raw Value (dBuV) + Correction Factor (dB/m).
2. Correction Factor (dB/m) = Antenna Factor (dB/m) + Cable Factor (dB).
3. The other emission levels were very low against the limit.
4. Margin value = Emission level – Limit value.
5. “ * “: Fundamental frequency.
6. The DH5 packet was the worse case duty cycle for a transmit dwell time on a channel, based upon bluetooth theory the transmitter is on 0.625 * 5 per 296.25 ms per channel. Therefore, the duty cycle correlation factor be equal to: $20\log(3.125 / 100) = -30.1$ dB.
7. Average value = peak reading + $20\log(\text{duty cycle})$.

| EUT TEST CONDITION | | MEASUREMENT DETAIL | |
|--------------------------|-----------------|--------------------|---------------------------|
| CHANNEL | Channel 78 | FREQUENCY RANGE | 1 ~ 25GHz |
| INPUT POWER | 120Vac, 60Hz | DETECTOR FUNCTION | Peak (PK) Average (AV) |
| ENVIRONMENTAL CONDITIONS | 24deg. C, 67%RH | TESTED BY | Martin Lee |

| ANTENNA POLARITY & TEST DISTANCE: HORIZONTAL AT 3 M | | | | | | | | |
|---|-------------|-------------------------|----------------|-------------|--------------------|----------------------|------------------|--------------------------|
| NO. | FREQ. (MHz) | EMISSION LEVEL (dBuV/m) | LIMIT (dBuV/m) | MARGIN (dB) | ANTENNA HEIGHT (m) | TABLE ANGLE (Degree) | RAW VALUE (dBuV) | CORRECTION FACTOR (dB/m) |
| 1 | *2480.00 | 104.3 PK | | | 1.21 H | 101 | 73.10 | 31.20 |
| 2 | *2480.00 | 74.2 AV | | | 1.21 H | 101 | 43.00 | 31.20 |
| 3 | 2483.50 | 46.5 PK | 74.0 | -27.5 | 1.21 H | 101 | 15.30 | 31.20 |
| 4 | 2483.50 | 16.4 AV | 54.0 | -37.6 | 1.21 H | 101 | -14.80 | 31.20 |
| 5 | 4960.00 | 55.0 PK | 74.0 | -19.0 | 1.12 H | 114 | 17.70 | 37.30 |
| 6 | 4960.00 | 24.9 AV | 54.0 | -29.1 | 1.12 H | 114 | -12.40 | 37.30 |
| ANTENNA POLARITY & TEST DISTANCE: VERTICAL AT 3 M | | | | | | | | |
| NO. | FREQ. (MHz) | EMISSION LEVEL (dBuV/m) | LIMIT (dBuV/m) | MARGIN (dB) | ANTENNA HEIGHT (m) | TABLE ANGLE (Degree) | RAW VALUE (dBuV) | CORRECTION FACTOR (dB/m) |
| 1 | *2480.00 | 98.9 PK | | | 1.02 V | 33 | 67.70 | 31.20 |
| 2 | *2480.00 | 68.8 AV | | | 1.02 V | 33 | 37.60 | 31.20 |
| 3 | 2483.50 | 41.1 PK | 74.0 | -32.9 | 1.41 V | 5 | 9.90 | 31.20 |
| 4 | 2483.50 | 11.0 AV | 54.0 | -43.0 | 1.41 V | 5 | -20.20 | 31.20 |
| 5 | 4960.00 | 53.4 PK | 74.0 | -20.6 | 1.20 V | 333 | 16.10 | 37.30 |
| 6 | 4960.00 | 23.3 AV | 54.0 | -30.7 | 1.20 V | 333 | -14.00 | 37.30 |

REMARKS:

1. Emission level (dBuV/m) = Raw Value (dBuV) + Correction Factor (dB/m).
2. Correction Factor (dB/m) = Antenna Factor (dB/m) + Cable Factor (dB).
3. The other emission levels were very low against the limit.
4. Margin value = Emission level – Limit value.
5. “ * “: Fundamental frequency.
6. The DH5 packet was the worse case duty cycle for a transmit dwell time on a channel, based upon bluetooth theory the transmitter is on 0.625 * 5 per 296.25 ms per channel. Therefore, the duty cycle correlation factor be equal to: $20\log(3.125 / 100) = -30.1$ dB.
7. Average value = peak reading + $20\log(\text{duty cycle})$.

BELOW 1GHz WORST-CASE DATA : GFSK

| EUT TEST CONDITION | | MEASUREMENT DETAIL | |
|--------------------------|-----------------|--------------------|---------------|
| CHANNEL | Channel 0 | FREQUENCY RANGE | Below 1000MHz |
| INPUT POWER | 120Vac, 60Hz | DETECTOR FUNCTION | Quasi-Peak |
| ENVIRONMENTAL CONDITIONS | 24deg. C, 67%RH | TESTED BY | Martin Lee |
| TEST MODE | A | | |

| ANTENNA POLARITY & TEST DISTANCE: HORIZONTAL AT 3 M | | | | | | | | |
|---|-------------|-------------------------|----------------|-------------|--------------------|----------------------|------------------|--------------------------|
| NO. | FREQ. (MHz) | EMISSION LEVEL (dBuV/m) | LIMIT (dBuV/m) | MARGIN (dB) | ANTENNA HEIGHT (m) | TABLE ANGLE (Degree) | RAW VALUE (dBuV) | CORRECTION FACTOR (dB/m) |
| 1 | 61.01 | 17.7 QP | 40.0 | -22.3 | 1.36 H | 248 | 4.30 | 13.40 |
| 2 | 154.33 | 18.6 QP | 43.5 | -24.9 | 1.00 H | 265 | 4.50 | 14.10 |
| 3 | 243.77 | 22.3 QP | 46.0 | -23.7 | 1.14 H | 161 | 9.50 | 12.80 |
| 4 | 319.60 | 19.6 QP | 46.0 | -26.4 | 1.58 H | 168 | 4.10 | 15.50 |
| 5 | 648.18 | 24.1 QP | 46.0 | -21.9 | 1.24 H | 208 | 1.60 | 22.50 |
| 6 | 774.56 | 29.3 QP | 46.0 | -16.7 | 1.74 H | 19 | 4.30 | 25.00 |
| ANTENNA POLARITY & TEST DISTANCE: VERTICAL AT 3 M | | | | | | | | |
| NO. | FREQ. (MHz) | EMISSION LEVEL (dBuV/m) | LIMIT (dBuV/m) | MARGIN (dB) | ANTENNA HEIGHT (m) | TABLE ANGLE (Degree) | RAW VALUE (dBuV) | CORRECTION FACTOR (dB/m) |
| 1 | 31.35 | 37.0 QP | 40.0 | -3.0 | 1.00 V | 151 | 24.50 | 12.50 |
| 2 | 59.06 | 33.1 QP | 40.0 | -6.9 | 1.33 V | 19 | 19.60 | 13.50 |
| 3 | 99.89 | 20.0 QP | 43.5 | -23.5 | 1.54 V | 106 | 10.60 | 9.40 |
| 4 | 129.06 | 15.4 QP | 43.5 | -28.1 | 1.57 V | 71 | 2.80 | 12.60 |
| 5 | 232.11 | 15.6 QP | 46.0 | -30.4 | 1.16 V | 294 | 3.30 | 12.30 |
| 6 | 344.87 | 17.0 QP | 46.0 | -29.0 | 1.20 V | 159 | 0.90 | 16.10 |

REMARKS:

1. Emission level (dBuV/m) = Raw Value (dBuV) + Correction Factor (dB/m).
2. Correction Factor (dB/m) = Antenna Factor (dB/m) + Cable Factor (dB).
3. The other emission levels were very low against the limit.
4. Margin value = Emission level – Limit value.

| EUT TEST CONDITION | | MEASUREMENT DETAIL | |
|--------------------------|-----------------|--------------------|---------------|
| CHANNEL | Channel 0 | FREQUENCY RANGE | Below 1000MHz |
| INPUT POWER (SYSTEM) | 120Vac, 60Hz | DETECTOR FUNCTION | Quasi-Peak |
| ENVIRONMENTAL CONDITIONS | 24deg. C, 67%RH | TESTED BY | Martin Lee |
| TEST MODE | B | | |

| ANTENNA POLARITY & TEST DISTANCE: HORIZONTAL AT 3 M | | | | | | | | |
|---|-------------|-------------------------|----------------|-------------|--------------------|----------------------|------------------|--------------------------|
| NO. | FREQ. (MHz) | EMISSION LEVEL (dBuV/m) | LIMIT (dBuV/m) | MARGIN (dB) | ANTENNA HEIGHT (m) | TABLE ANGLE (Degree) | RAW VALUE (dBuV) | CORRECTION FACTOR (dB/m) |
| 1 | 177.67 | 33.5 QP | 43.5 | -10.0 | 1.36 H | 75 | 20.60 | 12.90 |
| 2 | 247.66 | 36.5 QP | 46.0 | -9.5 | 1.00 H | 67 | 23.60 | 12.90 |
| 3 | 364.32 | 31.3 QP | 46.0 | -14.7 | 1.25 H | 128 | 14.70 | 16.60 |
| 4 | 432.37 | 34.4 QP | 46.0 | -11.6 | 1.00 H | 9 | 16.10 | 18.30 |
| 5 | 724.01 | 32.4 QP | 46.0 | -13.6 | 1.50 H | 109 | 8.80 | 23.60 |
| 6 | 836.78 | 39.7 QP | 46.0 | -6.3 | 1.13 H | 326 | 13.60 | 26.10 |
| ANTENNA POLARITY & TEST DISTANCE: VERTICAL AT 3 M | | | | | | | | |
| NO. | FREQ. (MHz) | EMISSION LEVEL (dBuV/m) | LIMIT (dBuV/m) | MARGIN (dB) | ANTENNA HEIGHT (m) | TABLE ANGLE (Degree) | RAW VALUE (dBuV) | CORRECTION FACTOR (dB/m) |
| 1 | 31.84 | 31.8 QP | 40.0 | -8.2 | 2.11 V | 242 | 19.30 | 12.50 |
| 2 | 97.95 | 34.4 QP | 43.5 | -9.1 | 1.00 V | 188 | 25.20 | 9.20 |
| 3 | 179.61 | 31.4 QP | 43.5 | -12.1 | 1.45 V | 173 | 18.80 | 12.60 |
| 4 | 226.27 | 37.2 QP | 46.0 | -8.8 | 1.65 V | 101 | 25.10 | 12.10 |
| 5 | 432.37 | 25.5 QP | 46.0 | -20.5 | 1.12 V | 215 | 7.20 | 18.30 |
| 6 | 667.63 | 29.7 QP | 46.0 | -16.3 | 1.02 V | 350 | 7.00 | 22.70 |

REMARKS:

1. Emission level (dBuV/m) = Raw Value (dBuV) + Correction Factor (dB/m).
2. Correction Factor (dB/m) = Antenna Factor (dB/m) + Cable Factor (dB).
3. The other emission levels were very low against the limit.
4. Margin value = Emission level – Limit value.



A D T

| EUT TEST CONDITION | | MEASUREMENT DETAIL | |
|--------------------------|-----------------|--------------------|---------------|
| CHANNEL | Channel 0 | FREQUENCY RANGE | Below 1000MHz |
| INPUT POWER | 3.7Vdc | DETECTOR FUNCTION | Quasi-Peak |
| ENVIRONMENTAL CONDITIONS | 24deg. C, 67%RH | TESTED BY | Martin Lee |
| TEST MODE | C | | |

| ANTENNA POLARITY & TEST DISTANCE: HORIZONTAL AT 3 M | | | | | | | | |
|---|-------------|-------------------------|----------------|-------------|--------------------|----------------------|------------------|--------------------------|
| NO. | FREQ. (MHz) | EMISSION LEVEL (dBuV/m) | LIMIT (dBuV/m) | MARGIN (dB) | ANTENNA HEIGHT (m) | TABLE ANGLE (Degree) | RAW VALUE (dBuV) | CORRECTION FACTOR (dB/m) |
| 1 | 37.68 | 18.6 QP | 40.0 | -21.4 | 1.32 H | 55 | 5.30 | 13.30 |
| 2 | 70.73 | 16.9 QP | 40.0 | -23.1 | 1.01 H | 82 | 4.80 | 12.10 |
| 3 | 129.06 | 13.9 QP | 43.5 | -29.6 | 1.63 H | 159 | 1.30 | 12.60 |
| 4 | 286.55 | 15.0 QP | 46.0 | -31.0 | 1.85 H | 254 | 0.60 | 14.40 |
| 5 | 329.32 | 16.3 QP | 46.0 | -29.7 | 1.63 H | 236 | 0.60 | 15.70 |
| 6 | 479.03 | 19.8 QP | 46.0 | -26.2 | 1.14 H | 82 | 0.40 | 19.40 |

| ANTENNA POLARITY & TEST DISTANCE: VERTICAL AT 3 M | | | | | | | | |
|---|-------------|-------------------------|----------------|-------------|--------------------|----------------------|------------------|--------------------------|
| NO. | FREQ. (MHz) | EMISSION LEVEL (dBuV/m) | LIMIT (dBuV/m) | MARGIN (dB) | ANTENNA HEIGHT (m) | TABLE ANGLE (Degree) | RAW VALUE (dBuV) | CORRECTION FACTOR (dB/m) |
| 1 | 31.84 | 24.1 QP | 40.0 | -15.9 | 1.44 V | 128 | 11.60 | 12.50 |
| 2 | 70.73 | 20.7 QP | 40.0 | -19.3 | 1.65 V | 229 | 8.60 | 12.10 |
| 3 | 99.89 | 22.5 QP | 43.5 | -21.0 | 1.78 V | 56 | 13.10 | 9.40 |
| 4 | 129.06 | 17.3 QP | 43.5 | -26.2 | 1.00 V | 8 | 4.70 | 12.60 |
| 5 | 162.11 | 15.4 QP | 43.5 | -28.1 | 1.36 V | 205 | 1.40 | 14.00 |
| 6 | 255.44 | 14.2 QP | 46.0 | -31.8 | 1.00 V | 357 | 1.00 | 13.20 |

REMARKS:

1. Emission level (dBuV/m) = Raw Value (dBuV) + Correction Factor (dB/m).
2. Correction Factor (dB/m) = Antenna Factor (dB/m) + Cable Factor (dB).
3. The other emission levels were very low against the limit.
4. Margin value = Emission level – Limit value.



A D T

| EUT TEST CONDITION | | MEASUREMENT DETAIL | |
|--------------------------|-----------------|--------------------|---------------|
| CHANNEL | Channel 0 | FREQUENCY RANGE | Below 1000MHz |
| INPUT POWER | 120Vac, 60Hz | DETECTOR FUNCTION | Quasi-Peak |
| ENVIRONMENTAL CONDITIONS | 25deg. C, 65%RH | TESTED BY | Ted Chang |
| TEST MODE | D | | |

| ANTENNA POLARITY & TEST DISTANCE: HORIZONTAL AT 3 M | | | | | | | | |
|---|-------------|-------------------------|----------------|-------------|--------------------|----------------------|------------------|--------------------------|
| NO. | FREQ. (MHz) | EMISSION LEVEL (dBuV/m) | LIMIT (dBuV/m) | MARGIN (dB) | ANTENNA HEIGHT (m) | TABLE ANGLE (Degree) | RAW VALUE (dBuV) | CORRECTION FACTOR (dB/m) |
| 1 | 57.12 | 30.5 QP | 40.0 | -9.5 | 2.00 H | 4 | 16.90 | 13.60 |
| 2 | 144.61 | 22.0 QP | 43.5 | -21.5 | 1.50 H | 249 | 8.40 | 13.60 |
| 3 | 274.88 | 27.0 QP | 46.0 | -19.0 | 1.00 H | 71 | 12.90 | 14.10 |
| 4 | 552.91 | 25.5 QP | 46.0 | -20.5 | 1.25 H | 130 | 4.10 | 21.40 |
| 5 | 712.35 | 28.8 QP | 46.0 | -17.2 | 1.00 H | 123 | 4.90 | 23.90 |
| 6 | 823.17 | 25.6 QP | 46.0 | -20.4 | 2.00 H | 4 | -0.30 | 25.90 |
| ANTENNA POLARITY & TEST DISTANCE: VERTICAL AT 3 M | | | | | | | | |
| NO. | FREQ. (MHz) | EMISSION LEVEL (dBuV/m) | LIMIT (dBuV/m) | MARGIN (dB) | ANTENNA HEIGHT (m) | TABLE ANGLE (Degree) | RAW VALUE (dBuV) | CORRECTION FACTOR (dB/m) |
| 1 | 57.12 | 26.0 QP | 40.0 | -14.0 | 1.00 V | 130 | 12.40 | 13.60 |
| 2 | 282.66 | 24.5 QP | 46.0 | -21.5 | 1.24 V | 154 | 10.10 | 14.40 |
| 3 | 444.03 | 20.1 QP | 46.0 | -25.9 | 1.00 V | 182 | 1.50 | 18.60 |
| 4 | 605.41 | 21.6 QP | 46.0 | -24.4 | 1.24 V | 62 | -1.00 | 22.60 |
| 5 | 706.51 | 24.9 QP | 46.0 | -21.1 | 1.24 V | 144 | 1.10 | 23.80 |
| 6 | 827.06 | 25.2 QP | 46.0 | -20.8 | 1.50 V | 249 | -0.80 | 26.00 |

REMARKS:

1. Emission level (dBuV/m) = Raw Value (dBuV) + Correction Factor (dB/m).
2. Correction Factor (dB/m) = Antenna Factor (dB/m) + Cable Factor (dB).
3. The other emission levels were very low against the limit.
4. Margin value = Emission level – Limit value.

4.2 CONDUCTED EMISSION MEASUREMENT

4.2.1 LIMITS OF CONDUCTED EMISSION MEASUREMENT

| FREQUENCY OF EMISSION (MHz) | CONDUCTED LIMIT (dB μ V) | |
|-----------------------------|------------------------------|----------|
| | Quasi-peak | Average |
| 0.15 ~ 0.5 | 66 to 56 | 56 to 46 |
| 0.5 ~ 5 | 56 | 46 |
| 5 ~ 30 | 60 | 50 |

- NOTE:**
1. The lower limit shall apply at the transition frequencies.
 2. The limit decreases in line with the logarithm of the frequency in the range of 0.15 to 0.50 MHz.
 3. All emanations from a class A/B digital device or system, including any network of conductors and apparatus connected thereto, shall not exceed the level of field strengths specified above.

4.2.2 TEST INSTRUMENTS

| DESCRIPTION & MANUFACTURER | MODEL NO. | SERIAL NO. | DATE OF CALIBRATION | DUE DATE OF CALIBRATION |
|---|--------------------------|----------------|---------------------|-------------------------|
| Test Receiver ROHDE & SCHWARZ | ESCS30 | 100291 | Nov. 23, 2011 | Nov. 22, 2012 |
| RF signal cable Woken | 5D-FB | Cable-HYC01-01 | Dec. 29, 2011 | Dec. 28, 2012 |
| LISN ROHDE & SCHWARZ (Peripheral) | ESH3-Z5 | 100312 | Jul. 02, 2012 | Jul. 01, 2013 |
| LISN ROHDE & SCHWARZ (EUT) | ESH3-Z5 | 835239/001 | Feb. 07, 2012 | Feb. 06, 2013 |
| Software ADT | BV ADT_Cond_ V7.3.7.3 | NA | NA | NA |

- NOTE:**
1. The calibration interval of the above test instruments is 12 months and the calibrations are traceable to NML/ROC and NIST/USA.
 2. The test was performed in HwaYa Shielded Room 1.
 3. The VCCI Site Registration No. is C-2040.

4.2.3 TEST PROCEDURES

- a. The EUT was placed 0.4 meters from the conducting wall of the shielded room with EUT being connected to the power mains through a line impedance stabilization network (LISN). Other support units were connected to the power mains through another LISN. The two LISNs provide 50 ohm/ 50uH of coupling impedance for the measuring instrument.
- b. Both lines of the power mains connected to the EUT were checked for maximum conducted interference.
- c. The frequency range from 150kHz to 30MHz was searched. Emission levels under (Limit - 20dB) was not recorded.

NOTE: All modes of operation were investigated and the worst-case emissions are reported.

4.2.4 DEVIATION FROM TEST STANDARD

No deviation.

4.2.5 TEST SETUP

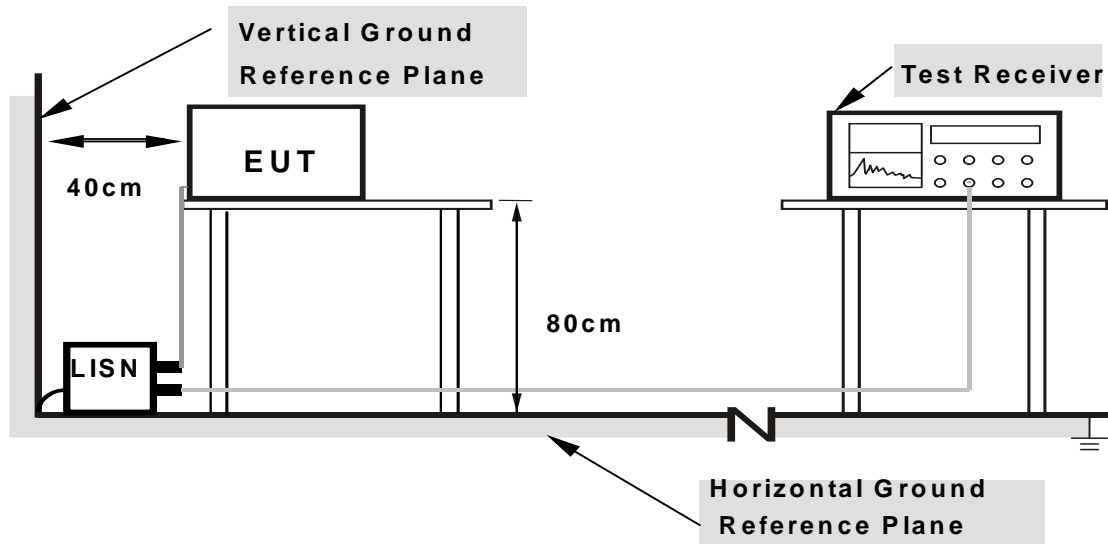

- Note:**
1. Support units were connected to second LISN.
 2. Both of LISNs (AMN) are 80 cm from EUT and at least 80 from other units and other metal planes

For the actual test configuration, please refer to the attached file (Test Setup Photo).

4.2.6 EUT OPERATING CONDITIONS

Same as 4.1.6.

4.2.7 TEST RESULTS

CONDUCTED WORST CASE DATA: GFSK

| | | | |
|-----------|--------|---------------|------|
| PHASE | Line 1 | 6dB BANDWIDTH | 9kHz |
| TEST MODE | A | | |

| No | Freq. [MHz] | Corr. Factor (dB) | Reading Value | | Emission Level | | Limit | | Margin | |
|----|----------------|-------------------------|---------------|------|----------------|------|-----------|-------|--------|--------|
| | | | [dB (uV)] | | [dB (uV)] | | [dB (uV)] | | (dB) | |
| | | | Q.P. | AV. | Q.P. | AV. | Q.P. | AV. | Q.P. | AV. |
| 1 | 0.21282 | 0.22 | 18.16 | 0.65 | 18.38 | 0.87 | 63.09 | 53.09 | -44.71 | -52.22 |
| 2 | 0.39739 | 0.24 | 28.56 | 8.54 | 28.80 | 8.78 | 57.91 | 47.91 | -29.11 | -39.13 |
| 3 | 1.59323 | 0.33 | 16.97 | 1.95 | 17.30 | 2.28 | 56.00 | 46.00 | -38.70 | -43.72 |
| 4 | 3.10596 | 0.40 | 16.38 | 2.01 | 16.78 | 2.41 | 56.00 | 46.00 | -39.22 | -43.59 |
| 5 | 5.11179 | 0.45 | 21.33 | 7.60 | 21.78 | 8.05 | 60.00 | 50.00 | -38.22 | -41.95 |
| 6 | 12.09896 | 0.58 | 12.83 | 0.77 | 13.41 | 1.35 | 60.00 | 50.00 | -46.59 | -48.65 |

REMARKS:

1. Q.P. and AV. are abbreviations of quasi-peak and average individually.
2. The emission levels of other frequencies were very low against the limit.
3. Margin value = Emission level - Limit value
4. Correction factor = Insertion loss + Cable loss
5. Emission Level = Correction Factor + Reading Value.

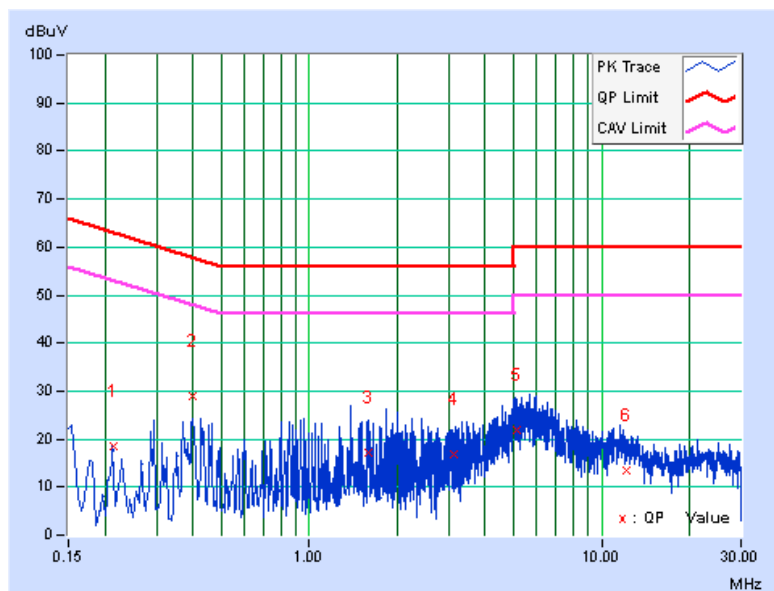

| | | | |
|-----------|--------|---------------|------|
| PHASE | Line 2 | 6dB BANDWIDTH | 9kHz |
| TEST MODE | A | | |

| No | Freq. [MHz] | Corr. Factor (dB) | Reading Value | | Emission Level | | Limit | | Margin | |
|----|----------------|----------------------|---------------|------|----------------|------|-----------|-------|--------|--------|
| | | | [dB (uV)] | | [dB (uV)] | | [dB (uV)] | | (dB) | |
| | | | Q.P. | AV. | Q.P. | AV. | Q.P. | AV. | Q.P. | AV. |
| 1 | 0.17374 | 0.20 | 22.16 | 3.25 | 22.36 | 3.45 | 64.78 | 54.78 | -42.42 | -51.33 |
| 2 | 0.25458 | 0.21 | 20.81 | 0.79 | 21.02 | 1.00 | 61.61 | 51.61 | -40.59 | -50.61 |
| 3 | 0.40024 | 0.22 | 25.92 | 6.70 | 26.14 | 6.92 | 57.85 | 47.85 | -31.71 | -40.93 |
| 4 | 0.93076 | 0.26 | 12.77 | 1.30 | 13.03 | 1.56 | 56.00 | 46.00 | -42.97 | -44.44 |
| 5 | 5.22909 | 0.47 | 20.34 | 8.73 | 20.81 | 9.20 | 60.00 | 50.00 | -39.19 | -40.80 |
| 6 | 9.77251 | 0.60 | 13.34 | 2.72 | 13.94 | 3.32 | 60.00 | 50.00 | -46.06 | -46.68 |

REMARKS:

1. Q.P. and AV. are abbreviations of quasi-peak and average individually.
2. The emission levels of other frequencies were very low against the limit.
3. Margin value = Emission level - Limit value
4. Correction factor = Insertion loss + Cable loss
5. Emission Level = Correction Factor + Reading Value.

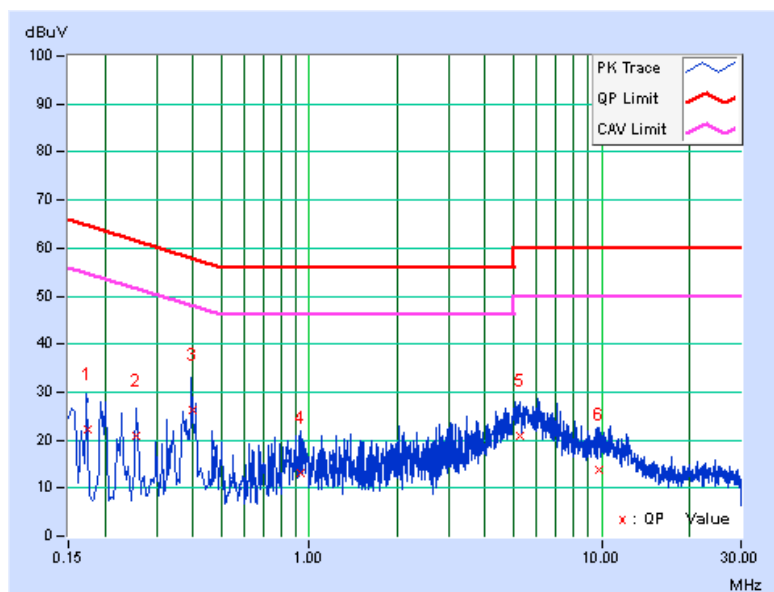

| | | | |
|------------------|--------|----------------------|------|
| PHASE | Line 1 | 6dB BANDWIDTH | 9kHz |
| TEST MODE | B | | |

| No | Freq. [MHz] | Corr. Factor (dB) | Reading Value | | Emission Level | | Limit | | Margin | |
|----------|----------------|----------------------|---------------|--------------|----------------|--------------|--------------|--------------|---------------|--------------|
| | | | [dB (uV)] | | [dB (uV)] | | [dB (uV)] | | (dB) | |
| | | | Q.P. | AV. | Q.P. | AV. | Q.P. | AV. | Q.P. | AV. |
| 1 | 0.17737 | 0.21 | 51.13 | 33.49 | 51.34 | 33.70 | 64.61 | 54.61 | -13.26 | -20.90 |
| 2 | 0.22429 | 0.22 | 44.99 | 30.28 | 45.21 | 30.50 | 62.66 | 52.66 | -17.45 | -22.16 |
| 3 | 0.49324 | 0.25 | 39.72 | 38.82 | 39.97 | 39.07 | 56.11 | 46.11 | -16.14 | -7.04 |
| 4 | 1.62717 | 0.33 | 35.81 | 32.07 | 36.14 | 32.40 | 56.00 | 46.00 | -19.86 | -13.60 |
| 5 | 2.74162 | 0.38 | 28.52 | 22.34 | 28.90 | 22.72 | 56.00 | 46.00 | -27.10 | -23.28 |
| 6 | 12.29055 | 0.58 | 35.71 | 30.40 | 36.29 | 30.98 | 60.00 | 50.00 | -23.71 | -19.02 |

REMARKS:

1. Q.P. and AV. are abbreviations of quasi-peak and average individually.
2. The emission levels of other frequencies were very low against the limit.
3. Margin value = Emission level - Limit value
4. Correction factor = Insertion loss + Cable loss
5. Emission Level = Correction Factor + Reading Value.

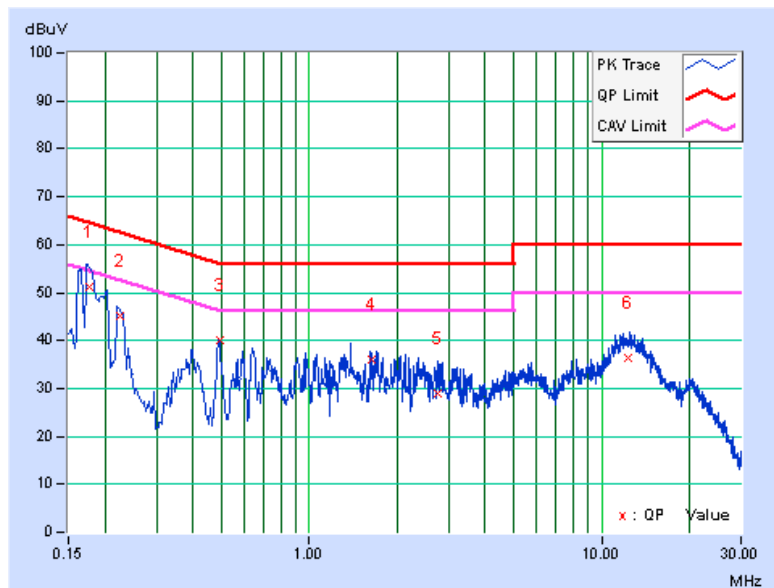

| | | | |
|------------------|--------|----------------------|------|
| PHASE | Line 2 | 6dB BANDWIDTH | 9kHz |
| TEST MODE | B | | |

| No | Freq. [MHz] | Corr. Factor (dB) | Reading Value | | Emission Level | | Limit | | Margin | |
|----|----------------|----------------------|---------------|-------|----------------|-------|-----------|-------|--------|--------|
| | | | [dB (uV)] | | [dB (uV)] | | [dB (uV)] | | (dB) | |
| | | | Q.P. | AV. | Q.P. | AV. | Q.P. | AV. | Q.P. | AV. |
| 1 | 0.16096 | 0.20 | 56.44 | 43.53 | 56.64 | 43.73 | 65.41 | 55.41 | -8.77 | -11.68 |
| 2 | 0.22434 | 0.20 | 44.32 | 27.70 | 44.52 | 27.90 | 62.66 | 52.66 | -18.13 | -24.75 |
| 3 | 0.49408 | 0.23 | 38.64 | 36.76 | 38.87 | 36.99 | 56.10 | 46.10 | -17.23 | -9.11 |
| 4 | 2.04244 | 0.31 | 34.75 | 29.66 | 35.06 | 29.97 | 56.00 | 46.00 | -20.94 | -16.03 |
| 5 | 5.87105 | 0.49 | 29.54 | 24.10 | 30.03 | 24.59 | 60.00 | 50.00 | -29.97 | -25.41 |
| 6 | 12.31032 | 0.67 | 35.35 | 30.19 | 36.02 | 30.86 | 60.00 | 50.00 | -23.98 | -19.14 |

REMARKS:

1. Q.P. and AV. are abbreviations of quasi-peak and average individually.
2. The emission levels of other frequencies were very low against the limit.
3. Margin value = Emission level - Limit value
4. Correction factor = Insertion loss + Cable loss
5. Emission Level = Correction Factor + Reading Value.

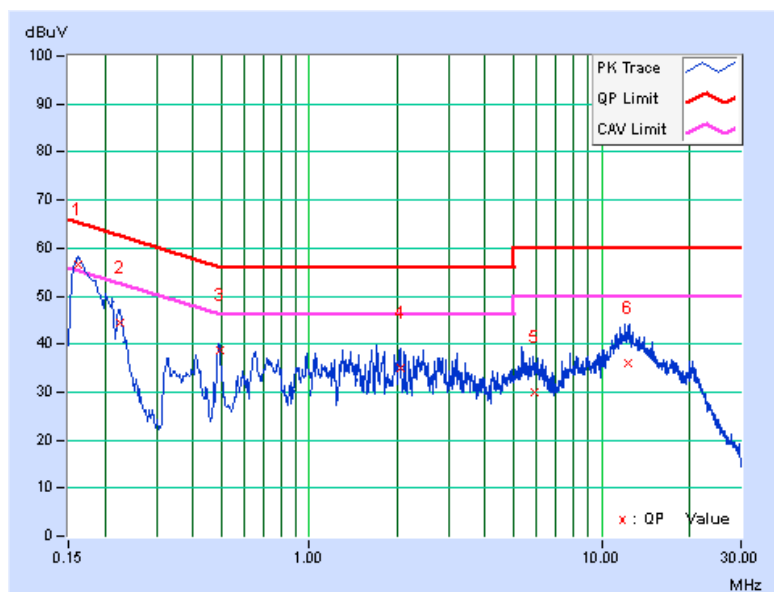

4.3 NUMBER OF HOPPING FREQUENCY USED

4.3.1 LIMIT OF HOPPING FREQUENCY USED

At least 15 channels frequencies, and should be equally spaced.

4.3.2 TEST SETUP

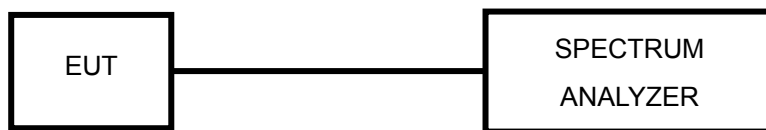

4.3.3 TEST INSTRUMENTS

Refer to section 4.1.2 to get information of above instrument.

4.3.4 TEST PROCEDURES

- a. Check the calibration of the measuring instrument (SA) using either an internal calibrator or a known signal from an external generator.
- b. Turn on the EUT and connect its antenna terminal to measurement via a low loss cable. Then set it to any one measured frequency within its operating range and make sure the instrument is operated in its linear range.
- c. Set the SA on MaxHold Mode, and then keep the EUT in hopping mode. Record all the signals from each channel until each one has been recorded.
- d. Set the SA on View mode and then plot the result on SA screen.
- e. Repeat above procedures until all frequencies measured were complete.

4.3.5 DEVIATION FROM TEST STANDARD

No deviation.

4.3.6 TEST RESULTS

There are 79 hopping frequencies in the hopping mode. Please refer to next two pages for the test result. On the plots, it shows that the hopping frequencies are equally spaced.

GFSK

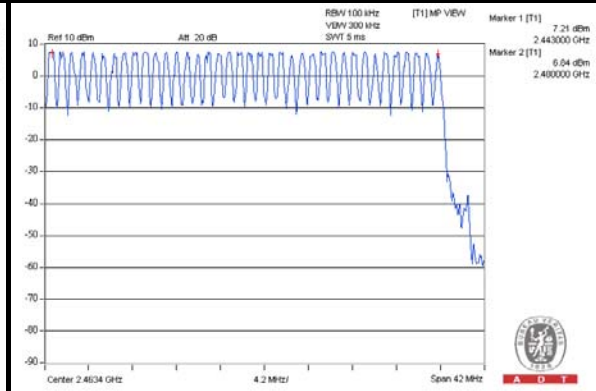
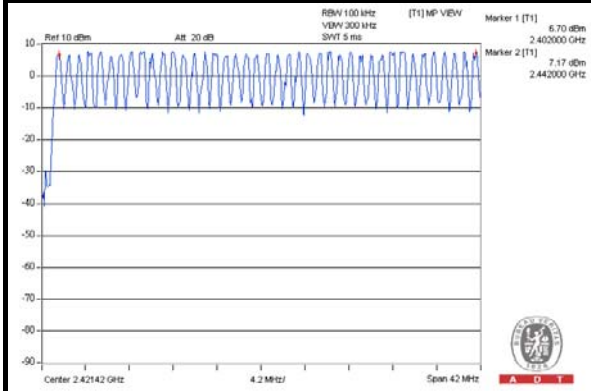

8DPSK

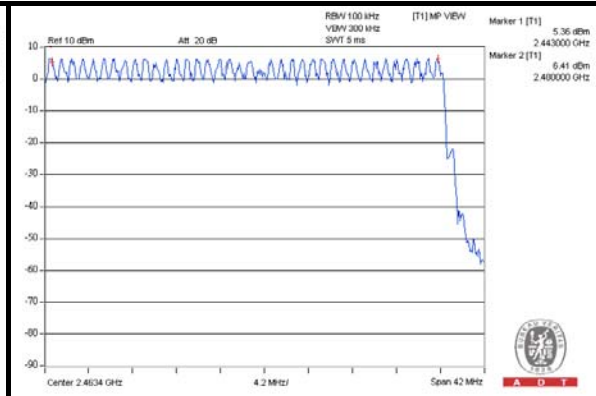
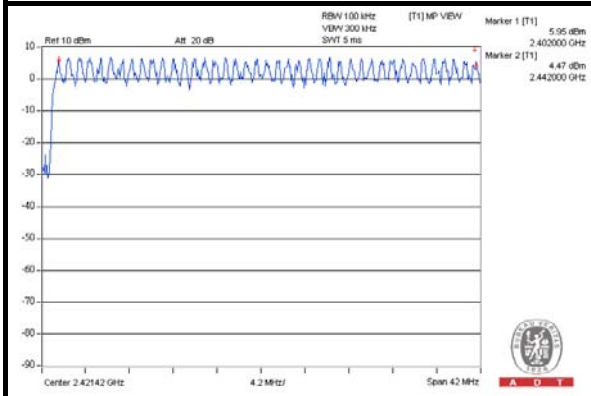

4.4 DWELL TIME ON EACH CHANNEL

4.4.1 LIMIT OF DWELL TIME USED

The average time of occupancy on any channel shall not be greater than 0.4 seconds within a period of 0.4 seconds multiplied by the number of hopping channels employed.

4.4.2 TEST SETUP

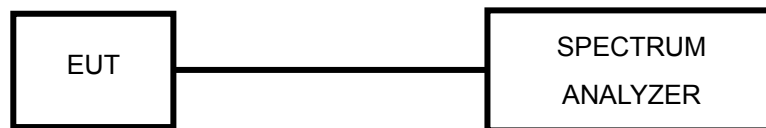

4.4.3 TEST INSTRUMENTS

Refer to section 4.1.2 to get information of above instrument.

4.4.4 TEST PROCEDURES

- a. Check the calibration of the measuring instrument (SA) using either an internal calibrator or a known signal from an external generator.
- b. Turn on the EUT and connect its antenna terminal to measurement via a low loss cable. Then set it to any one measured frequency within its operating range and make sure the instrument is operated in its linear range.
- c. Adjust the center frequency of SA on any frequency be measured and set SA to zero span mode. And then, set RBW and VBW of spectrum analyzer to proper value.
- d. Measure the time duration of one transmission on the measured frequency. And then plot the result with time difference of this time duration.
- e. Repeat above procedures until all different time-slot modes have been completed.

4.4.5 DEVIATION FROM TEST STANDARD

No deviation.

4.4.6 TEST RESULTS

GFSK

| Mode | Number of transmission in a 31.6 (79Hopping*0.4) | Length of transmission time (msec) | Result (msec) | Limit (msec) |
|------|--|------------------------------------|---------------|--------------|
| DH1 | 51 (times / 5 sec) * 6.32 = 332.32 times | 0.456 | 146.978 | 400 |
| DH3 | 25 (times / 5 sec) * 6.32 = 158.00 times | 1.710 | 270.180 | 400 |
| DH5 | 17 (times / 5 sec) * 6.32 = 107.44 times | 3.000 | 322.320 | 400 |

NOTE: Test plots of the transmitting time slot are shown as below.

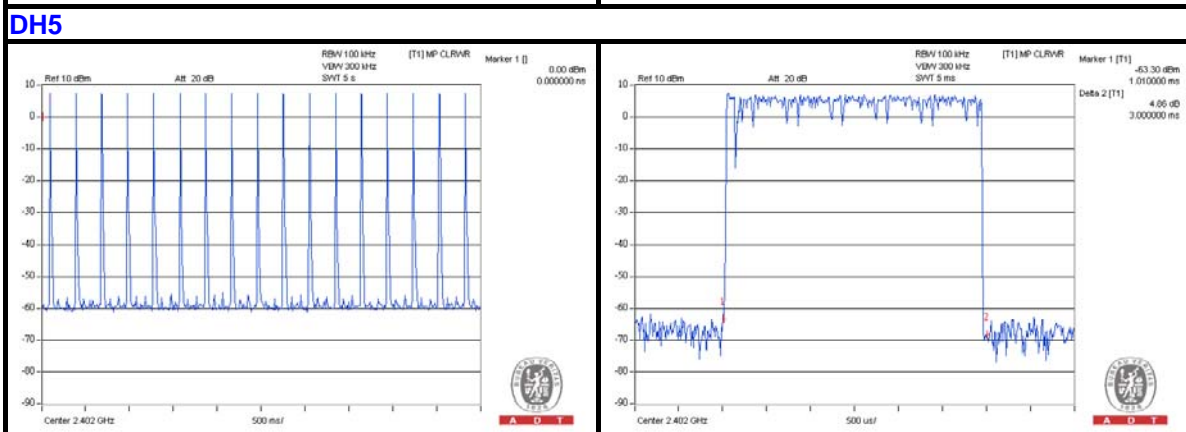
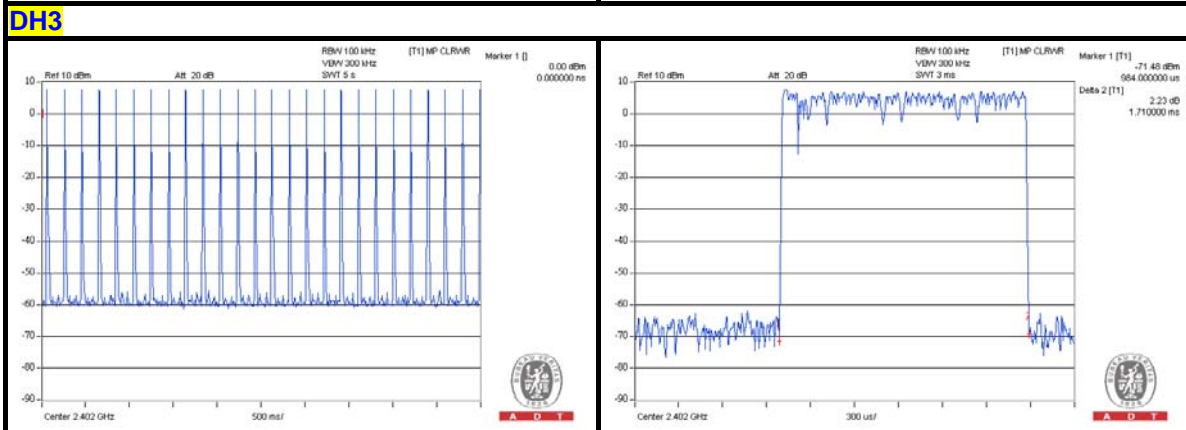
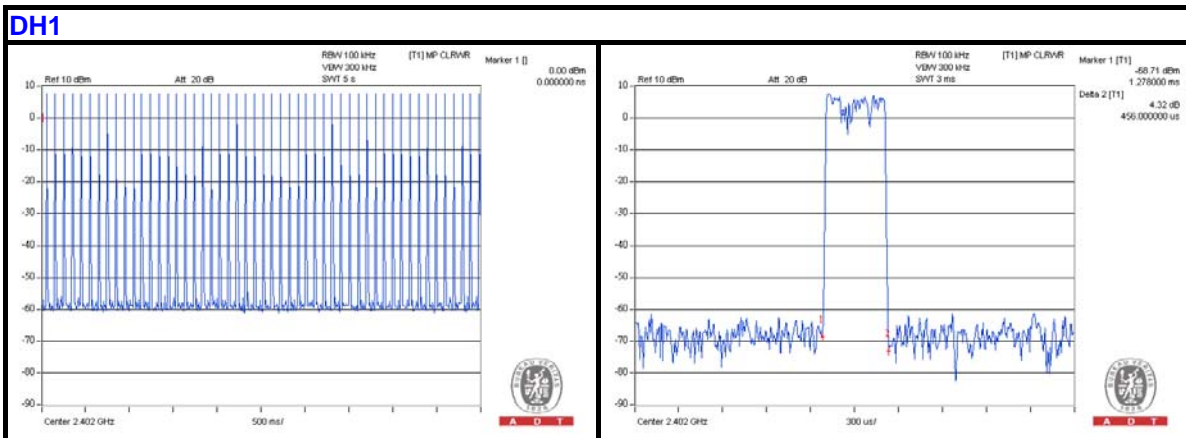



A D T

8DPSK

| Mode | Number of transmission in a 31.6 (79Hopping*0.4) | Length of transmission time (msec) | Result (msec) | Limit (msec) |
|------|--|------------------------------------|---------------|--------------|
| DH1 | $51 \text{ (times / 5 sec)} * 6.32 = 332.32 \text{ times}$ | 0.498 | 160.515 | 400 |
| DH3 | $25 \text{ (times / 5 sec)} * 6.32 = 158.00 \text{ times}$ | 1.740 | 274.920 | 400 |
| DH5 | $17 \text{ (times / 5 sec)} * 6.32 = 107.44 \text{ times}$ | 3.050 | 327.692 | 400 |

NOTE: Test plots of the transmitting time slot are shown as below.

DH1

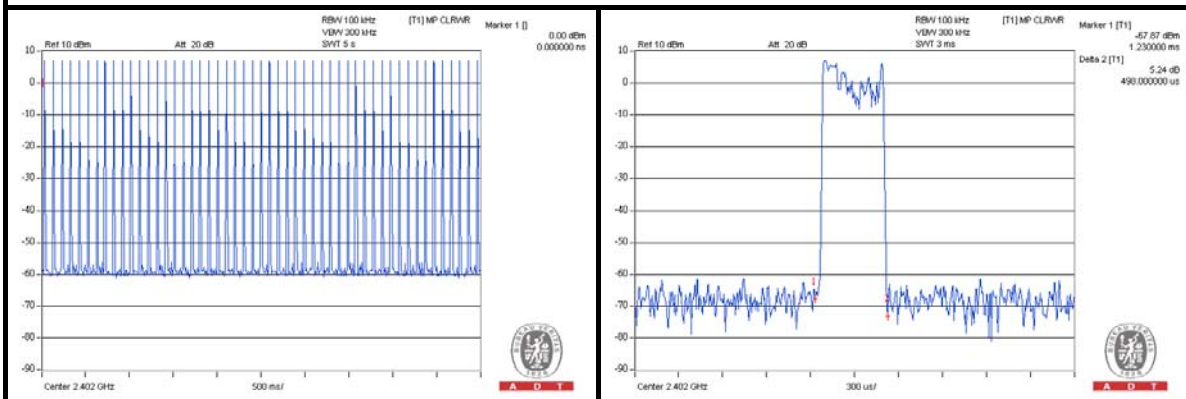

DH3

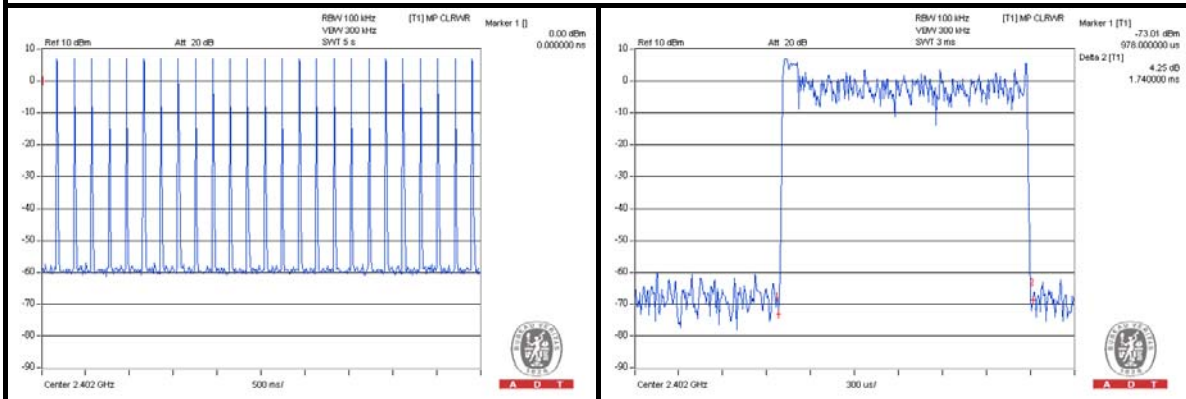

DH5

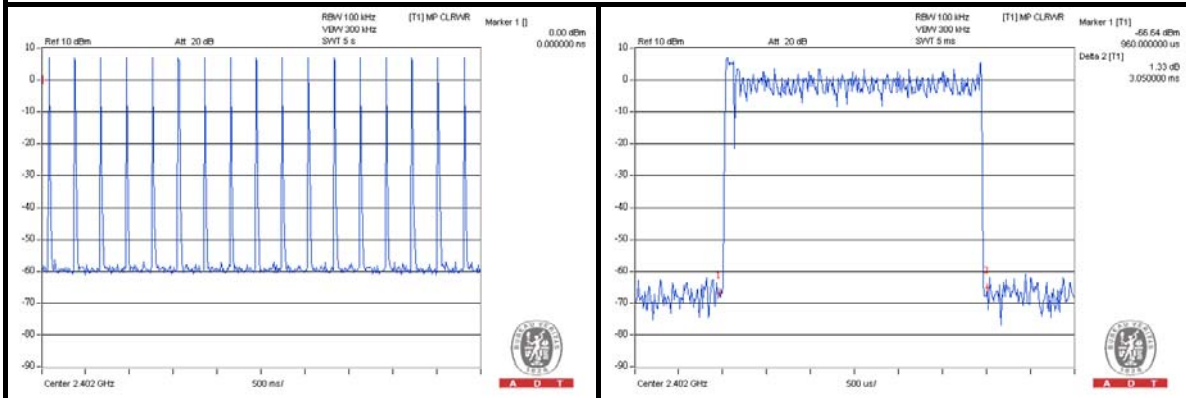

4.5 CHANNEL BANDWIDTH

4.5.1 LIMITS OF CHANNEL BANDWIDTH

For frequency hopping system operating in the 2400-2483.5MHz, If the 20dB bandwidth of hopping channel is greater than 25kHz, two-thirds 20dB bandwidth of hopping channel shall be a minimum limit for the hopping channel separation.

4.5.2 TEST SETUP

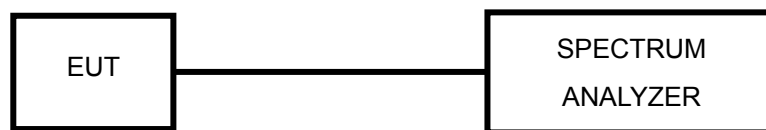

4.5.3 TEST INSTRUMENTS

Refer to section 4.1.2 to get information of above instrument.

4.5.4 TEST PROCEDURE

- a. Check the calibration of the measuring instrument using either an internal calibrator or a known signal from an external generator.
- b. Turn on the EUT and connect it to measurement instrument. Then set it to any one convenient frequency within its operating range. Set a reference level on the measuring instrument equal to the highest peak value.
- c. Measure the frequency difference of two frequencies that were attenuated 20dB from the reference level. Record the frequency difference as the emission bandwidth.
- d. Repeat above procedures until all frequencies measured were complete.

4.5.5 DEVIATION FROM TEST STANDARD

No deviation.

4.5.6 EUT OPERATING CONDITION

The software provided by client enabled the EUT to transmit and receive data at lowest, middle and highest channel frequencies individually.

4.5.7 TEST RESULTS

| CHANNEL | FREQUENCY (MHz) | 20dB BANDWIDTH (MHz) | |
|---------|-----------------|----------------------|-------|
| | | GFSK | 8DPSK |
| 0 | 2402 | 0.875 | 1.220 |
| 39 | 2441 | 0.871 | 1.210 |
| 78 | 2480 | 0.846 | 1.220 |

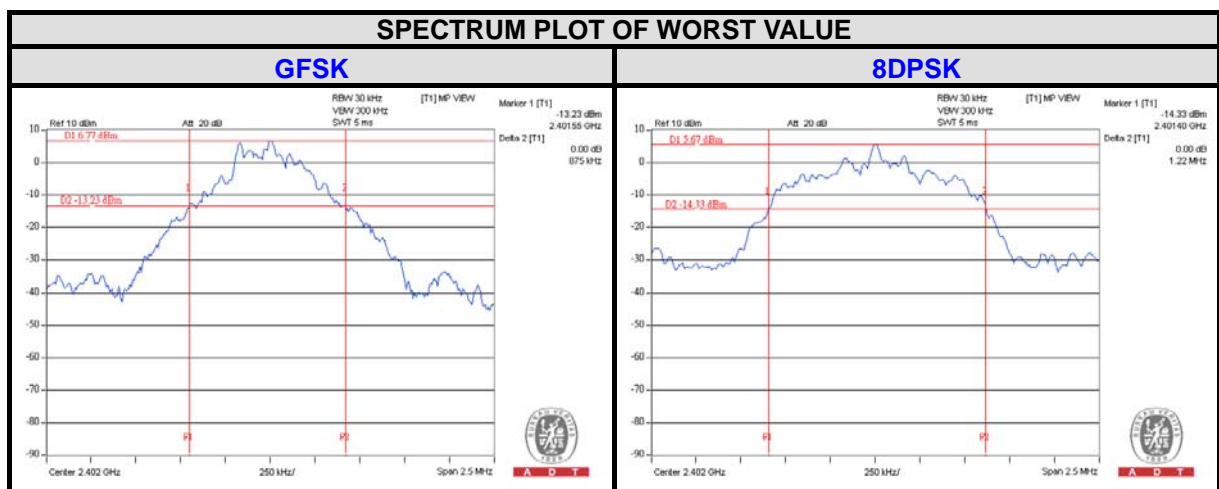

4.6 HOPPING CHANNEL SEPARATION

4.6.1 LIMIT OF HOPPING CHANNEL SEPARATION

At least 25kHz or two-third of 20dB hopping channel bandwidth (whichever is greater).

4.6.2 TEST SETUP

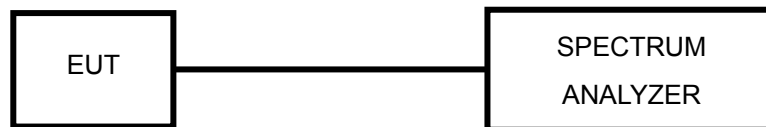

4.6.3 TEST INSTRUMENTS

Refer to section 4.1.2 to get information of above instrument.

4.6.4 TEST PROCEDURES

1. Check the calibration of the measuring instrument using either an internal calibrator or a known signal from an external generator.
2. Turn on the EUT and connect it to measurement instrument. Then set it to any one convenient frequency within its operating range.
3. By using the MaxHold function record the separation of two adjacent channels.
4. Measure the frequency difference of these two adjacent channels by SA MARK function. And then plot the result on SA screen.
5. Repeat above procedures until all frequencies measured were complete.

4.6.5 DEVIATION FROM TEST STANDARD

No deviation.

4.6.6 TEST RESULTS

| CHANNEL | FREQUENCY (MHz) | ADJACENT CHANNEL SEPARATION (MHz) | | 20dB BANDWIDTH (MHz) | | MINIMUM LIMIT (MHz) | | PASS / FAIL |
|---------|-----------------|-----------------------------------|-------|----------------------|-------|---------------------|-------|-------------|
| | | GFSK | 8DPSK | GFSK | 8DPSK | GFSK | 8DPSK | |
| 0 | 2402 | 1.000 | 1.010 | 0.875 | 1.220 | 0.583 | 0.813 | PASS |
| 39 | 2441 | 1.010 | 1.010 | 0.871 | 1.210 | 0.581 | 0.807 | PASS |
| 78 | 2480 | 1.000 | 1.000 | 0.846 | 1.220 | 0.564 | 0.813 | PASS |

NOTE: The minimum limit is two-third 20dB bandwidth.

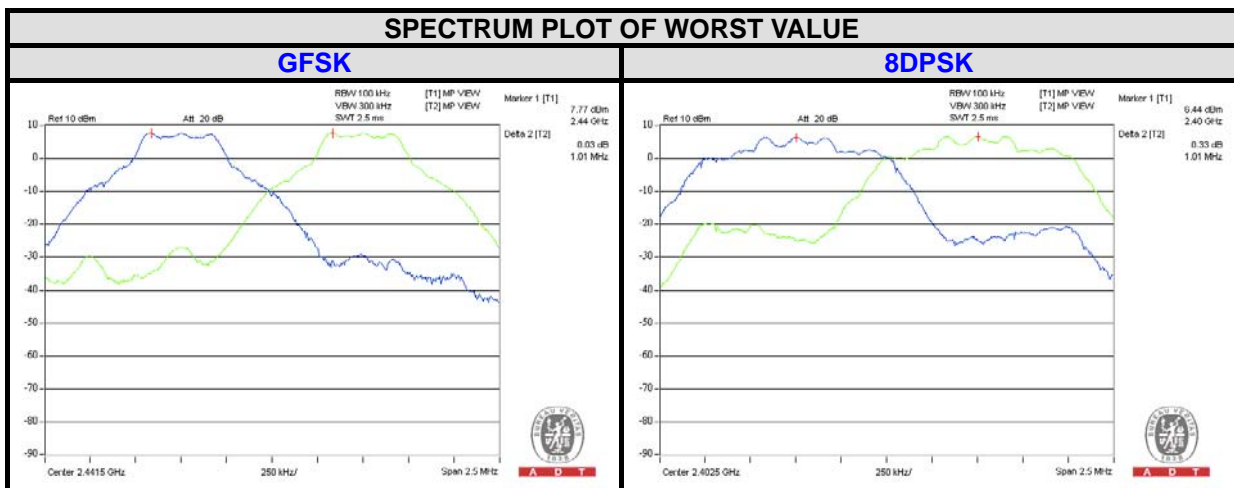

4.7 MAXIMUM OUTPUT POWER

4.7.1 LIMITS OF MAXIMUM OUTPUT POWER MEASUREMENT

The Maximum Output Power Measurement is 125mW.

4.7.2 TEST SETUP

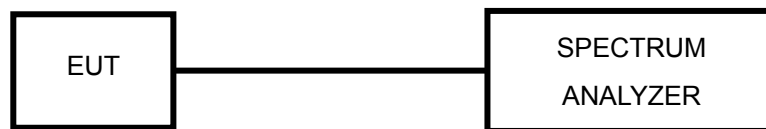

4.7.3 TEST INSTRUMENTS

Refer to section 4.1.2 to get information of above instrument.

4.7.4 TEST PROCEDURES

- a. Check the calibration of the measuring instrument using either an internal calibrator or a known signal from an external generator.
- b. Turn on the EUT and connect it to measurement instrument. Then set it to any one convenient frequency within its operating range. Set a reference level on the measuring instrument equal to the highest peak value.
- c. The center frequency of the spectrum analyzer is set to the fundamental frequency and using 3MHz RBW and 10 MHz VBW.
- d. Measure the captured power within the band and recording the plot.
- e. Repeat above procedures until all frequencies required were complete.

4.7.5 DEVIATION FROM TEST STANDARD

No deviation.

4.7.6 EUT OPERATING CONDITION

The software provided by client enabled the EUT to transmit and receive data at lowest, middle and highest channel frequencies individually.

4.7.7 TEST RESULTS

| CHANNEL | FREQUENCY (MHz) | OUTPUT POWER (mW) | | OUTPUT POWER (dBm) | | POWER LIMIT (mW) | PASS / FAIL |
|---------|-----------------|-------------------|-------|--------------------|-------|------------------|-------------|
| | | GFSK | 8DPSK | GFSK | 8DPSK | | |
| 0 | 2402 | 6.653 | 5.420 | 8.23 | 7.34 | 125 | PASS |
| 39 | 2441 | 6.653 | 5.508 | 8.23 | 7.41 | 125 | PASS |
| 78 | 2480 | 6.561 | 5.346 | 8.17 | 7.28 | 125 | PASS |

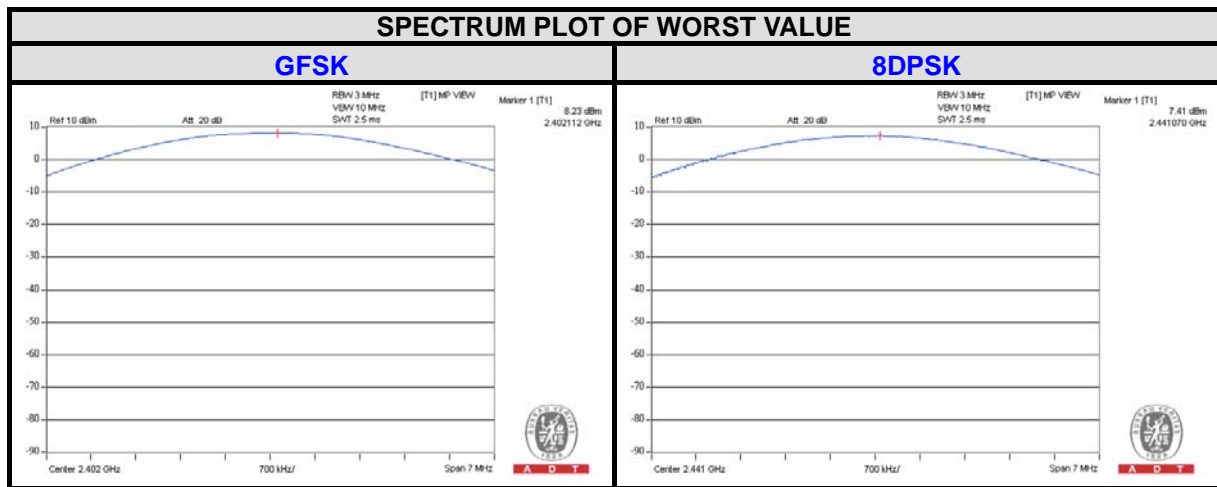

4.8 CONDUCTED OUT OF BAND EMISSION MEASUREMENT

4.8.1 LIMITS OF CONDUCTED OUT OF BAND EMISSION MEASUREMENT

Below -20dB of the highest emission level of operating band (in 100KHz RBW).

4.8.2 TEST INSTRUMENTS

Refer to section 4.1.2 to get information of above instrument.

4.8.3 TEST PROCEDURE

1. Set RBW = 100 kHz.
2. Set VBW = 300 kHz.
3. Set span to encompass the spectrum to be examined
4. Detector = peak.
5. Trace Mode = max hold.
6. Sweep = auto couple.

4.8.4 DEVIATION FROM TEST STANDARD

No deviation.

4.8.5 EUT OPERATING CONDITION

The software provided by client enabled the EUT to transmit continuously.

4.8.6 TEST RESULTS

The spectrum plots are attached on the following images. D1 line indicates the highest level, D2 line indicates the 20dB offset below D1. It shows compliance with the requirement.



A D T

GFSK

Hopping disabled_ Low Channel

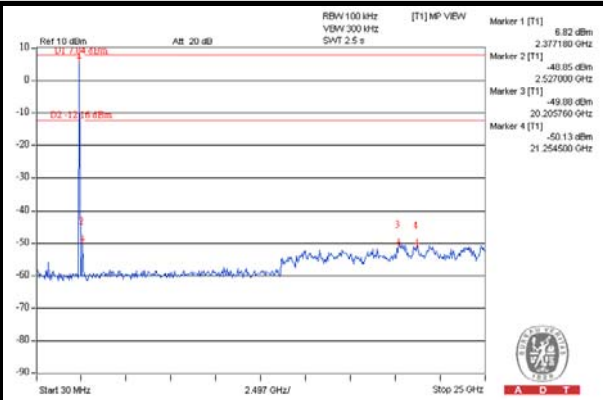
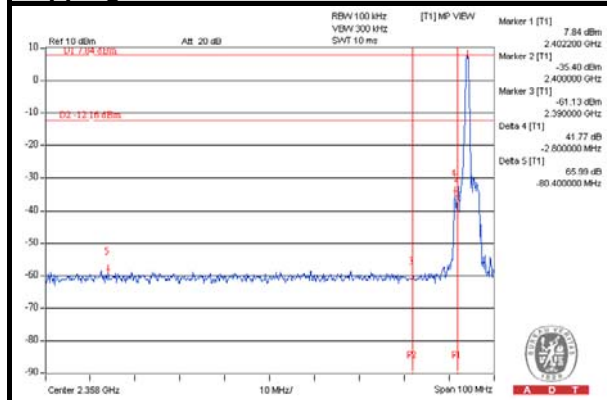

Hopping disabled_ High Channel

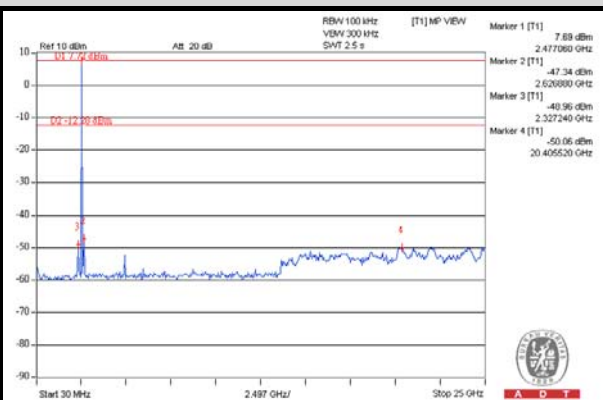
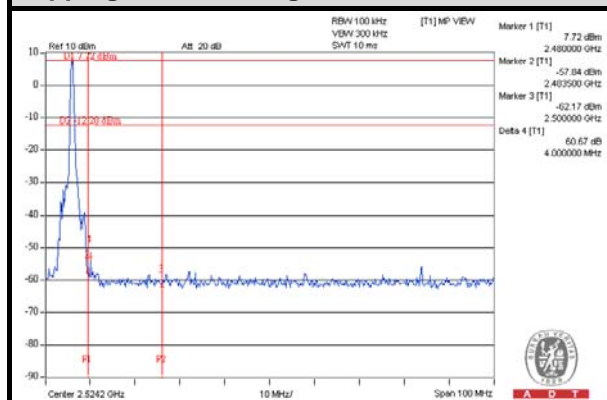

Hopping enabled_ Low Channel

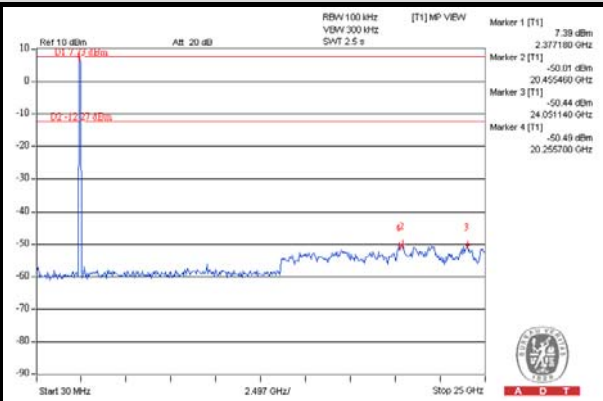
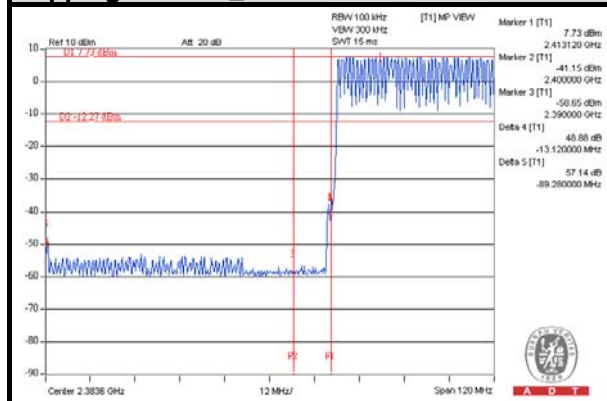

Hopping enabled_ High Channel

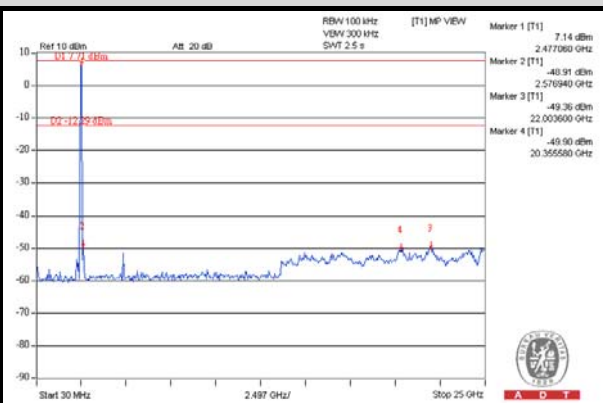
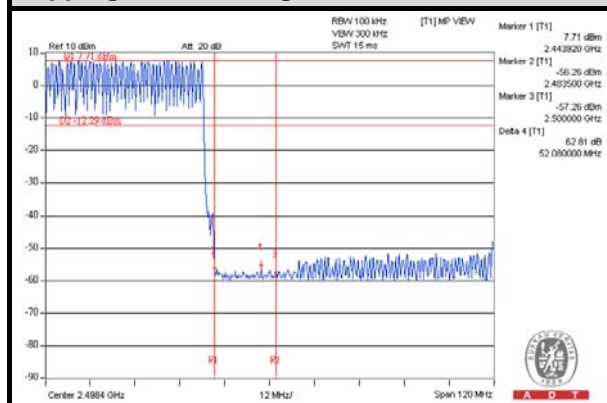



A D T

8DPSK

Hopping disabled_ Low Channel

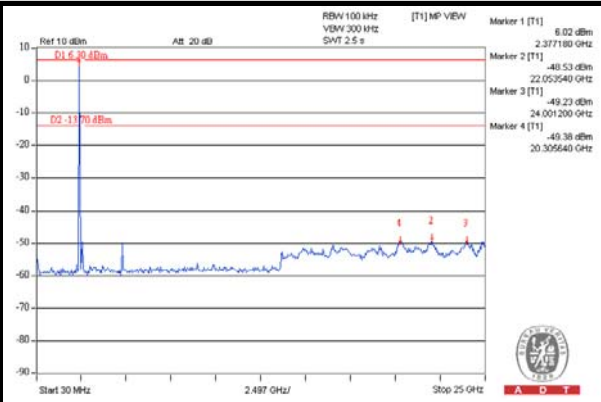
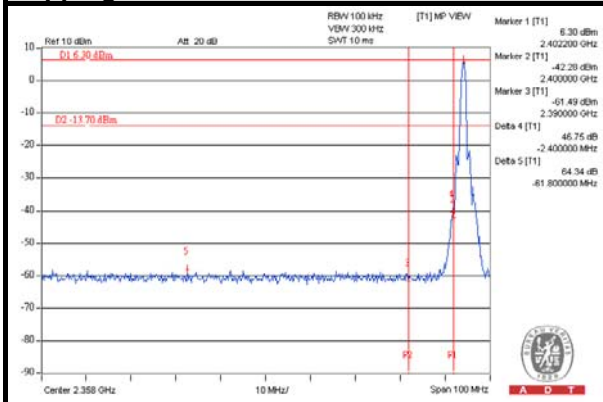

Hopping disabled_ High Channel

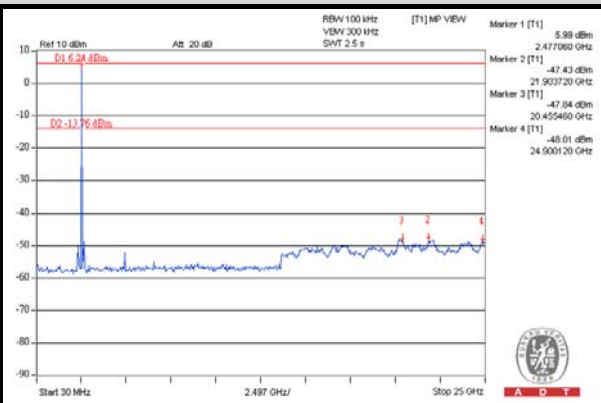
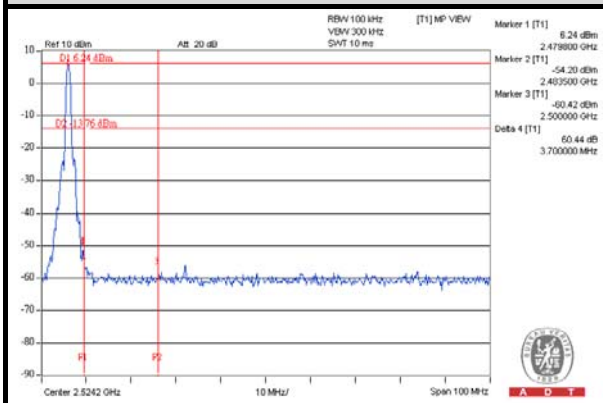

Hopping enabled_ Low Channel

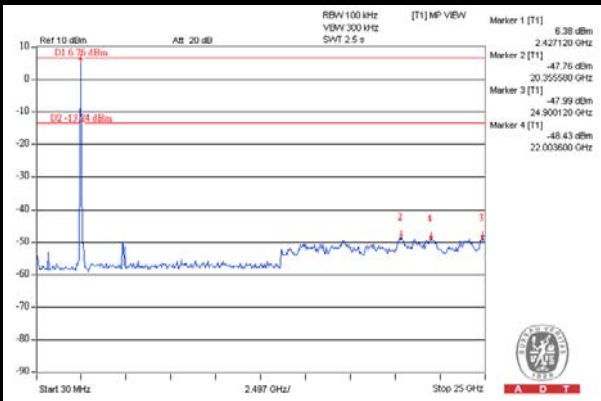
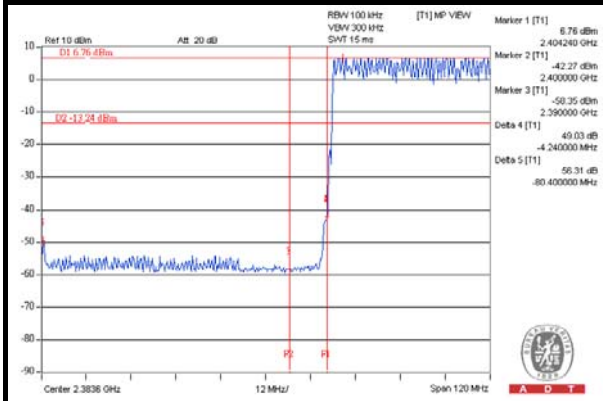

Hopping enabled_ High Channel

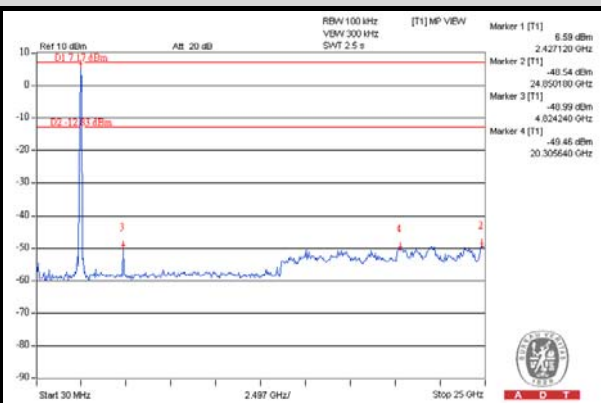
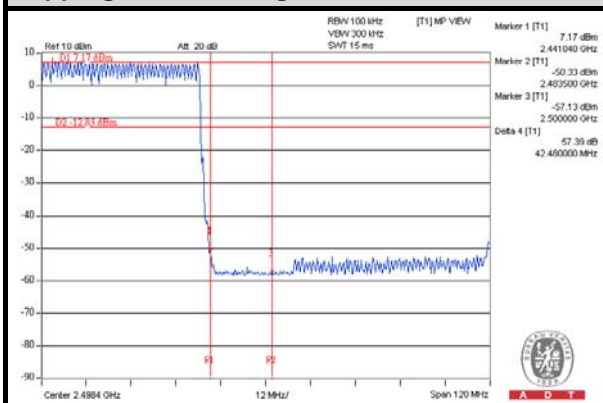

5. TEST TYPES AND RESULTS (FOR BLUETOOTH LE 4.0)

5.1 RADIATED EMISSION AND BANDEDGE MEASUREMENT

5.1.1 LIMITS OF RADIATED EMISSION AND BANDEDGE MEASUREMENT

Same as 4.1.1.

5.1.2 TEST INSTRUMENTS

Same as 4.1.2.

5.1.3 TEST PROCEDURES

Same as 4.1.3.

5.1.4 DEVIATION FROM TEST STANDARD

No deviation.

5.1.5 TEST SETUP

Same as 4.1.5.

5.1.6 EUT OPERATING CONDITIONS

Same as 4.1.6.

5.1.7 TEST RESULTS

ABOVE 1GHz DATA

| EUT TEST CONDITION | | MEASUREMENT DETAIL | |
|--------------------------|-----------------|--------------------|---------------------------|
| CHANNEL | Channel 0 | FREQUENCY RANGE | 1 ~ 25GHz |
| INPUT POWER | 120Vac, 60Hz | DETECTOR FUNCTION | Peak (PK) Average (AV) |
| ENVIRONMENTAL CONDITIONS | 24deg. C, 67%RH | TESTED BY | Martin Lee |

| ANTENNA POLARITY & TEST DISTANCE: HORIZONTAL AT 3 M | | | | | | | | |
|---|-------------|-------------------------|----------------|-------------|--------------------|----------------------|------------------|--------------------------|
| NO. | FREQ. (MHz) | EMISSION LEVEL (dBuV/m) | LIMIT (dBuV/m) | MARGIN (dB) | ANTENNA HEIGHT (m) | TABLE ANGLE (Degree) | RAW VALUE (dBuV) | CORRECTION FACTOR (dB/m) |
| 1 | 2390.00 | 56.3 PK | 74.0 | -17.7 | 1.38 H | 330 | 25.50 | 30.80 |
| 2 | 2390.00 | 43.8 AV | 54.0 | -10.2 | 1.38 H | 330 | 13.00 | 30.80 |
| 3 | *2402.00 | 102.1 PK | | | 1.38 H | 330 | 71.20 | 30.90 |
| 4 | *2402.00 | 98.9 AV | | | 1.38 H | 330 | 68.00 | 30.90 |
| 5 | 4804.00 | 55.4 PK | 74.0 | -18.6 | 1.43 H | 37 | 18.50 | 36.90 |
| 6 | 4804.00 | 50.5 AV | 54.0 | -3.5 | 1.43 H | 37 | 13.60 | 36.90 |
| 7 | #7206.00 | 57.2 PK | 82.1 | -24.9 | 1.00 H | 328 | 13.90 | 43.30 |
| 8 | #7206.00 | 49.8 AV | 78.9 | -29.1 | 1.00 H | 328 | 6.50 | 43.30 |
| ANTENNA POLARITY & TEST DISTANCE: VERTICAL AT 3 M | | | | | | | | |
| NO. | FREQ. (MHz) | EMISSION LEVEL (dBuV/m) | LIMIT (dBuV/m) | MARGIN (dB) | ANTENNA HEIGHT (m) | TABLE ANGLE (Degree) | RAW VALUE (dBuV) | CORRECTION FACTOR (dB/m) |
| 1 | 2390.00 | 54.7 PK | 74.0 | -19.3 | 1.00 V | 192 | 23.90 | 30.80 |
| 2 | 2390.00 | 43.8 AV | 54.0 | -10.2 | 1.00 V | 192 | 13.00 | 30.80 |
| 3 | *2402.00 | 98.5 PK | | | 1.00 V | 192 | 67.60 | 30.90 |
| 4 | *2402.00 | 95.0 AV | | | 1.00 V | 192 | 64.10 | 30.90 |
| 5 | 4804.00 | 55.9 PK | 74.0 | -18.1 | 1.05 V | 151 | 19.00 | 36.90 |
| 6 | 4804.00 | 51.7 AV | 54.0 | -2.3 | 1.05 V | 151 | 14.80 | 36.90 |
| 7 | #7206.00 | 57.0 PK | 78.5 | -21.5 | 1.12 V | 218 | 13.70 | 43.30 |
| 8 | #7206.00 | 49.7 AV | 75.0 | -25.3 | 1.12 V | 218 | 6.40 | 43.30 |

REMARKS:

1. Emission level (dBuV/m) = Raw Value (dBuV) + Correction Factor (dB/m).
2. Correction Factor (dB/m) = Antenna Factor (dB/m) + Cable Factor (dB).
3. The other emission levels were very low against the limit.
4. Margin value = Emission level – Limit value.
5. “ * “: Fundamental frequency.
6. “#”: The radiated frequency is out the restricted band.

| EUT TEST CONDITION | | MEASUREMENT DETAIL | |
|--------------------------|-----------------|--------------------|---------------------------|
| CHANNEL | Channel 19 | FREQUENCY RANGE | 1 ~ 25GHz |
| INPUT POWER | 120Vac, 60Hz | DETECTOR FUNCTION | Peak (PK) Average (AV) |
| ENVIRONMENTAL CONDITIONS | 24deg. C, 67%RH | TESTED BY | Martin Lee |

| ANTENNA POLARITY & TEST DISTANCE: HORIZONTAL AT 3 M | | | | | | | | |
|---|----------------|-------------------------|----------------|-------------|--------------------|----------------------|------------------|--------------------------|
| NO. | FREQ. (MHz) | EMISSION LEVEL (dBuV/m) | LIMIT (dBuV/m) | MARGIN (dB) | ANTENNA HEIGHT (m) | TABLE ANGLE (Degree) | RAW VALUE (dBuV) | CORRECTION FACTOR (dB/m) |
| 1 | *2440.00 | 103.6 PK | | | 1.34 H | 7 | 72.60 | 31.00 |
| 2 | *2440.00 | 99.7 AV | | | 1.34 H | 7 | 68.70 | 31.00 |
| 3 | 4880.00 | 50.5 PK | 74.0 | -23.5 | 1.29 H | 181 | 13.40 | 37.10 |
| 4 | 4880.00 | 45.4 AV | 54.0 | -8.6 | 1.29 H | 181 | 8.30 | 37.10 |
| 5 | 7320.00 | 60.2 PK | 74.0 | -13.8 | 1.55 H | 136 | 16.50 | 43.70 |
| 6 | 7320.00 | 52.9 AV | 54.0 | -1.1 | 1.55 H | 136 | 9.20 | 43.70 |

| ANTENNA POLARITY & TEST DISTANCE: VERTICAL AT 3 M | | | | | | | | |
|---|-------------|-------------------------|----------------|-------------|--------------------|----------------------|------------------|--------------------------|
| NO. | FREQ. (MHz) | EMISSION LEVEL (dBuV/m) | LIMIT (dBuV/m) | MARGIN (dB) | ANTENNA HEIGHT (m) | TABLE ANGLE (Degree) | RAW VALUE (dBuV) | CORRECTION FACTOR (dB/m) |
| 1 | *2440.00 | 99.2 PK | | | 1.01 V | 191 | 68.20 | 31.00 |
| 2 | *2440.00 | 95.7 AV | | | 1.01 V | 191 | 64.70 | 31.00 |
| 3 | 4880.00 | 50.5 PK | 74.0 | -23.5 | 1.14 V | 168 | 13.40 | 37.10 |
| 4 | 4880.00 | 42.9 AV | 54.0 | -11.1 | 1.14 V | 168 | 5.80 | 37.10 |
| 5 | 7320.00 | 56.0 PK | 74.0 | -18.0 | 1.04 V | 226 | 12.30 | 43.70 |
| 6 | 7320.00 | 47.6 AV | 54.0 | -6.4 | 1.04 V | 226 | 3.90 | 43.70 |

REMARKS:

1. Emission level (dBuV/m) = Raw Value (dBuV) + Correction Factor (dB/m).
2. Correction Factor (dB/m) = Antenna Factor (dB/m) + Cable Factor (dB).
3. The other emission levels were very low against the limit.
4. Margin value = Emission level – Limit value.
5. “ * “: Fundamental frequency.

| EUT TEST CONDITION | | MEASUREMENT DETAIL | |
|--------------------------|-----------------|--------------------|---------------------------|
| CHANNEL | Channel 39 | FREQUENCY RANGE | 1 ~ 25GHz |
| INPUT POWER | 120Vac, 60Hz | DETECTOR FUNCTION | Peak (PK) Average (AV) |
| ENVIRONMENTAL CONDITIONS | 24deg. C, 67%RH | TESTED BY | Martin Lee |

| ANTENNA POLARITY & TEST DISTANCE: HORIZONTAL AT 3 M | | | | | | | | |
|---|-------------|-------------------------|----------------|-------------|--------------------|----------------------|------------------|--------------------------|
| NO. | FREQ. (MHz) | EMISSION LEVEL (dBuV/m) | LIMIT (dBuV/m) | MARGIN (dB) | ANTENNA HEIGHT (m) | TABLE ANGLE (Degree) | RAW VALUE (dBuV) | CORRECTION FACTOR (dB/m) |
| 1 | *2480.00 | 103.4 PK | | | 1.33 H | 325 | 72.20 | 31.20 |
| 2 | *2480.00 | 99.7 AV | | | 1.33 H | 325 | 68.50 | 31.20 |
| 3 | 2483.50 | 51.8 PK | 74.0 | -22.2 | 1.33 H | 325 | 20.60 | 31.20 |
| 4 | 2483.50 | 48.1 AV | 54.0 | -5.9 | 1.33 H | 325 | 16.90 | 31.20 |
| 5 | 4960.00 | 55.2 PK | 74.0 | -18.8 | 1.37 H | 20 | 17.90 | 37.30 |
| 6 | 4960.00 | 50.8 AV | 54.0 | -3.2 | 1.37 H | 20 | 13.50 | 37.30 |
| 7 | 7440.00 | 56.7 PK | 74.0 | -17.3 | 1.56 H | 139 | 12.70 | 44.00 |
| 8 | 7440.00 | 48.5 AV | 54.0 | -5.5 | 1.56 H | 139 | 4.50 | 44.00 |
| ANTENNA POLARITY & TEST DISTANCE: VERTICAL AT 3 M | | | | | | | | |
| NO. | FREQ. (MHz) | EMISSION LEVEL (dBuV/m) | LIMIT (dBuV/m) | MARGIN (dB) | ANTENNA HEIGHT (m) | TABLE ANGLE (Degree) | RAW VALUE (dBuV) | CORRECTION FACTOR (dB/m) |
| 1 | *2480.00 | 98.6 PK | | | 1.25 V | 192 | 67.40 | 31.20 |
| 2 | *2480.00 | 95.0 AV | | | 1.25 V | 192 | 63.80 | 31.20 |
| 3 | 2483.50 | 49.0 PK | 74.0 | -25.0 | 1.25 V | 192 | 17.80 | 31.20 |
| 4 | 2483.50 | 45.4 AV | 54.0 | -8.6 | 1.25 V | 192 | 14.20 | 31.20 |
| 5 | 4960.00 | 56.1 PK | 74.0 | -17.9 | 1.42 V | 150 | 18.80 | 37.30 |
| 6 | 4960.00 | 50.4 AV | 54.0 | -3.6 | 1.42 V | 150 | 13.10 | 37.30 |
| 7 | 7440.00 | 55.1 PK | 74.0 | -18.9 | 1.53 V | 210 | 11.10 | 44.00 |
| 8 | 7440.00 | 43.4 AV | 54.0 | -10.6 | 1.53 V | 210 | -0.60 | 44.00 |

REMARKS:

1. Emission level (dBuV/m) = Raw Value (dBuV) + Correction Factor (dB/m).
2. Correction Factor (dB/m) = Antenna Factor (dB/m) + Cable Factor (dB).
3. The other emission levels were very low against the limit.
4. Margin value = Emission level – Limit value.
5. “ * “: Fundamental frequency.



A D T

BELOW 1GHz WORST-CASE DATA

| EUT TEST CONDITION | | MEASUREMENT DETAIL | |
|--------------------------|-----------------|--------------------|---------------|
| CHANNEL | Channel 0 | FREQUENCY RANGE | Below 1000MHz |
| INPUT POWER | 120Vac, 60Hz | DETECTOR FUNCTION | Quasi-Peak |
| ENVIRONMENTAL CONDITIONS | 25deg. C, 65%RH | TESTED BY | Chris Lin |
| TEST MODE | A | | |

| ANTENNA POLARITY & TEST DISTANCE: HORIZONTAL AT 3 M | | | | | | | | |
|---|-------------|-------------------------|----------------|-------------|--------------------|----------------------|------------------|--------------------------|
| NO. | FREQ. (MHz) | EMISSION LEVEL (dBuV/m) | LIMIT (dBuV/m) | MARGIN (dB) | ANTENNA HEIGHT (m) | TABLE ANGLE (Degree) | RAW VALUE (dBuV) | CORRECTION FACTOR (dB/m) |
| 1 | 107.67 | 16.5 QP | 43.5 | -27.0 | 1.99 H | 153 | 6.10 | 10.40 |
| 2 | 239.88 | 27.7 QP | 46.0 | -18.3 | 1.24 H | 119 | 15.10 | 12.60 |
| 3 | 356.54 | 21.8 QP | 46.0 | -24.2 | 1.50 H | 6 | 5.40 | 16.40 |
| 4 | 617.08 | 24.2 QP | 46.0 | -21.8 | 1.24 H | 15 | 1.90 | 22.30 |
| 5 | 731.79 | 25.1 QP | 46.0 | -20.9 | 1.00 H | 162 | 1.30 | 23.80 |
| 6 | 887.33 | 25.8 QP | 46.0 | -20.2 | 1.00 H | 104 | -0.90 | 26.70 |
| ANTENNA POLARITY & TEST DISTANCE: VERTICAL AT 3 M | | | | | | | | |
| NO. | FREQ. (MHz) | EMISSION LEVEL (dBuV/m) | LIMIT (dBuV/m) | MARGIN (dB) | ANTENNA HEIGHT (m) | TABLE ANGLE (Degree) | RAW VALUE (dBuV) | CORRECTION FACTOR (dB/m) |
| 1 | 66.84 | 22.4 QP | 40.0 | -17.6 | 1.24 V | 15 | 9.70 | 12.70 |
| 2 | 234.05 | 19.3 QP | 46.0 | -26.7 | 1.50 V | 329 | 6.90 | 12.40 |
| 3 | 467.36 | 19.1 QP | 46.0 | -26.9 | 1.99 V | 33 | -0.10 | 19.20 |
| 4 | 706.51 | 23.2 QP | 46.0 | -22.8 | 1.99 V | 117 | 0.00 | 23.20 |
| 5 | 834.84 | 34.3 QP | 46.0 | -11.7 | 1.50 V | 339 | 8.30 | 26.00 |
| 6 | 939.83 | 26.7 QP | 46.0 | -19.3 | 1.50 V | 226 | -0.50 | 27.20 |

REMARKS:

1. Emission level (dBuV/m) = Raw Value (dBuV) + Correction Factor (dB/m).
2. Correction Factor (dB/m) = Antenna Factor (dB/m) + Cable Factor (dB).
3. The other emission levels were very low against the limit.
4. Margin value = Emission level – Limit value.



| EUT TEST CONDITION | | MEASUREMENT DETAIL | |
|--------------------------|-----------------|--------------------|---------------|
| CHANNEL | Channel 0 | FREQUENCY RANGE | Below 1000MHz |
| INPUT POWER (SYSTEM) | 120Vac, 60Hz | DETECTOR FUNCTION | Quasi-Peak |
| ENVIRONMENTAL CONDITIONS | 24deg. C, 67%RH | TESTED BY | Martin Lee |
| TEST MODE | B | | |

| ANTENNA POLARITY & TEST DISTANCE: HORIZONTAL AT 3 M | | | | | | | | |
|---|-------------|-------------------------|----------------|-------------|--------------------|----------------------|------------------|--------------------------|
| NO. | FREQ. (MHz) | EMISSION LEVEL (dBuV/m) | LIMIT (dBuV/m) | MARGIN (dB) | ANTENNA HEIGHT (m) | TABLE ANGLE (Degree) | RAW VALUE (dBuV) | CORRECTION FACTOR (dB/m) |
| 1 | 175.72 | 33.3 QP | 43.5 | -10.2 | 1.32 H | 91 | 20.20 | 13.10 |
| 2 | 255.44 | 37.1 QP | 46.0 | -8.9 | 1.00 H | 76 | 23.90 | 13.20 |
| 3 | 335.15 | 29.8 QP | 46.0 | -16.2 | 1.05 H | 29 | 13.90 | 15.90 |
| 4 | 364.32 | 31.7 QP | 46.0 | -14.3 | 1.65 H | 126 | 15.10 | 16.60 |
| 5 | 663.74 | 29.7 QP | 46.0 | -16.3 | 1.85 H | 4 | 7.00 | 22.70 |
| 6 | 840.67 | 35.5 QP | 46.0 | -10.5 | 1.12 H | 46 | 9.40 | 26.10 |
| ANTENNA POLARITY & TEST DISTANCE: VERTICAL AT 3 M | | | | | | | | |
| NO. | FREQ. (MHz) | EMISSION LEVEL (dBuV/m) | LIMIT (dBuV/m) | MARGIN (dB) | ANTENNA HEIGHT (m) | TABLE ANGLE (Degree) | RAW VALUE (dBuV) | CORRECTION FACTOR (dB/m) |
| 1 | 99.89 | 34.8 QP | 43.5 | -8.7 | 1.45 V | 157 | 25.40 | 9.40 |
| 2 | 177.67 | 31.0 QP | 43.5 | -12.5 | 1.36 V | 186 | 18.10 | 12.90 |
| 3 | 230.16 | 35.4 QP | 46.0 | -10.6 | 1.14 V | 157 | 23.20 | 12.20 |
| 4 | 432.37 | 24.5 QP | 46.0 | -21.5 | 1.85 V | 271 | 6.20 | 18.30 |
| 5 | 663.74 | 27.4 QP | 46.0 | -18.6 | 1.36 V | 358 | 4.70 | 22.70 |
| 6 | 840.67 | 30.5 QP | 46.0 | -15.5 | 1.00 V | 246 | 4.40 | 26.10 |

REMARKS:

1. Emission level (dBuV/m) = Raw Value (dBuV) + Correction Factor (dB/m).
2. Correction Factor (dB/m) = Antenna Factor (dB/m) + Cable Factor (dB).
3. The other emission levels were very low against the limit.
4. Margin value = Emission level – Limit value.



| EUT TEST CONDITION | | MEASUREMENT DETAIL | |
|--------------------------|-----------------|--------------------|---------------|
| CHANNEL | Channel 0 | FREQUENCY RANGE | Below 1000MHz |
| INPUT POWER | 3.7Vdc | DETECTOR FUNCTION | Quasi-Peak |
| ENVIRONMENTAL CONDITIONS | 24deg. C, 67%RH | TESTED BY | Martin Lee |
| TEST MODE | C | | |

| ANTENNA POLARITY & TEST DISTANCE: HORIZONTAL AT 3 M | | | | | | | | |
|---|-------------|-------------------------|----------------|-------------|--------------------|----------------------|------------------|--------------------------|
| NO. | FREQ. (MHz) | EMISSION LEVEL (dBuV/m) | LIMIT (dBuV/m) | MARGIN (dB) | ANTENNA HEIGHT (m) | TABLE ANGLE (Degree) | RAW VALUE (dBuV) | CORRECTION FACTOR (dB/m) |
| 1 | 41.22 | 19.3 QP | 40.0 | -20.7 | 1.32 H | 241 | 5.60 | 13.70 |
| 2 | 111.24 | 18.4 QP | 43.5 | -25.1 | 1.32 H | 52 | 7.60 | 10.80 |
| 3 | 133.23 | 17.2 QP | 43.5 | -26.3 | 1.12 H | 157 | 4.20 | 13.00 |
| 4 | 275.55 | 18.0 QP | 46.0 | -28.0 | 1.32 H | 254 | 4.00 | 14.00 |
| 5 | 365.22 | 19.7 QP | 46.0 | -26.3 | 1.00 H | 0 | 3.10 | 16.60 |
| 6 | 482.22 | 24.6 QP | 46.0 | -21.4 | 1.37 H | 78 | 5.10 | 19.50 |
| ANTENNA POLARITY & TEST DISTANCE: VERTICAL AT 3 M | | | | | | | | |
| NO. | FREQ. (MHz) | EMISSION LEVEL (dBuV/m) | LIMIT (dBuV/m) | MARGIN (dB) | ANTENNA HEIGHT (m) | TABLE ANGLE (Degree) | RAW VALUE (dBuV) | CORRECTION FACTOR (dB/m) |
| 1 | 32.25 | 20.6 QP | 40.0 | -19.4 | 1.14 V | 256 | 8.00 | 12.60 |
| 2 | 105.66 | 18.3 QP | 43.5 | -25.2 | 1.20 V | 142 | 8.20 | 10.10 |
| 3 | 128.47 | 16.7 QP | 43.5 | -26.8 | 1.04 V | 14 | 4.10 | 12.60 |
| 4 | 274.22 | 16.5 QP | 46.0 | -29.5 | 1.63 V | 333 | 2.50 | 14.00 |
| 5 | 364.22 | 18.4 QP | 46.0 | -27.6 | 1.25 V | 5 | 1.80 | 16.60 |
| 6 | 502.33 | 23.0 QP | 46.0 | -23.0 | 2.10 V | 44 | 3.00 | 20.00 |

REMARKS:

1. Emission level (dBuV/m) = Raw Value (dBuV) + Correction Factor (dB/m).
2. Correction Factor (dB/m) = Antenna Factor (dB/m) + Cable Factor (dB).
3. The other emission levels were very low against the limit.
4. Margin value = Emission level – Limit value.



| EUT TEST CONDITION | | MEASUREMENT DETAIL | |
|--------------------------|-----------------|--------------------|---------------|
| CHANNEL | Channel 0 | FREQUENCY RANGE | Below 1000MHz |
| INPUT POWER | 120Vac, 60Hz | DETECTOR FUNCTION | Quasi-Peak |
| ENVIRONMENTAL CONDITIONS | 25deg. C, 65%RH | TESTED BY | Chris Lin |
| TEST MODE | D | | |

| ANTENNA POLARITY & TEST DISTANCE: HORIZONTAL AT 3 M | | | | | | | | |
|---|-------------|-------------------------|----------------|-------------|--------------------|----------------------|------------------|--------------------------|
| NO. | FREQ. (MHz) | EMISSION LEVEL (dBuV/m) | LIMIT (dBuV/m) | MARGIN (dB) | ANTENNA HEIGHT (m) | TABLE ANGLE (Degree) | RAW VALUE (dBuV) | CORRECTION FACTOR (dB/m) |
| 1 | 57.12 | 30.8 QP | 40.0 | -9.2 | 2.00 H | 195 | 17.20 | 13.60 |
| 2 | 251.55 | 24.1 QP | 46.0 | -21.9 | 1.00 H | 285 | 10.90 | 13.20 |
| 3 | 436.26 | 20.0 QP | 46.0 | -26.0 | 2.00 H | 33 | 1.50 | 18.50 |
| 4 | 531.53 | 24.0 QP | 46.0 | -22.0 | 1.50 H | 217 | 3.10 | 20.90 |
| 5 | 654.02 | 28.2 QP | 46.0 | -17.8 | 1.24 H | 216 | 5.10 | 23.10 |
| 6 | 832.89 | 25.9 QP | 46.0 | -20.1 | 1.00 H | 193 | -0.10 | 26.00 |
| ANTENNA POLARITY & TEST DISTANCE: VERTICAL AT 3 M | | | | | | | | |
| NO. | FREQ. (MHz) | EMISSION LEVEL (dBuV/m) | LIMIT (dBuV/m) | MARGIN (dB) | ANTENNA HEIGHT (m) | TABLE ANGLE (Degree) | RAW VALUE (dBuV) | CORRECTION FACTOR (dB/m) |
| 1 | 57.12 | 25.1 QP | 40.0 | -14.9 | 1.00 V | 120 | 11.50 | 13.60 |
| 2 | 251.55 | 22.0 QP | 46.0 | -24.0 | 2.00 V | 175 | 8.80 | 13.20 |
| 3 | 444.03 | 18.4 QP | 46.0 | -27.6 | 2.00 V | 173 | -0.20 | 18.60 |
| 4 | 648.18 | 24.3 QP | 46.0 | -21.7 | 1.50 V | 159 | 1.30 | 23.00 |
| 5 | 755.12 | 24.9 QP | 46.0 | -21.1 | 1.25 V | 189 | 0.20 | 24.70 |
| 6 | 883.44 | 26.1 QP | 46.0 | -19.9 | 1.00 V | 220 | -0.60 | 26.70 |

REMARKS:

1. Emission level (dBuV/m) = Raw Value (dBuV) + Correction Factor (dB/m).
2. Correction Factor (dB/m) = Antenna Factor (dB/m) + Cable Factor (dB).
3. The other emission levels were very low against the limit.
4. Margin value = Emission level – Limit value.

5.2 CONDUCTED EMISSION MEASUREMENT

5.2.1 LIMITS OF CONDUCTED EMISSION MEASUREMENT

Same as 4.2.1.

5.2.2 TEST INSTRUMENTS

Same as 4.2.2.

5.2.3 TEST PROCEDURES

Same as 4.2.3.

5.2.4 DEVIATION FROM TEST STANDARD

No deviation.

5.2.5 TEST SETUP

Same as 4.2.5.

5.2.6 EUT OPERATING CONDITIONS

Same as 4.2.6.

5.2.7 TEST RESULTS

CONDUCTED WORST CASE DATA:

| | | | |
|-----------|--------|---------------|------|
| PHASE | Line 1 | 6dB BANDWIDTH | 9kHz |
| TEST MODE | A | | |

| No | Freq. [MHz] | Corr. Factor (dB) | Reading Value | | Emission Level | | Limit | | Margin | |
|----|----------------|-------------------------|---------------|------|----------------|------|-----------|-------|--------|--------|
| | | | [dB (uV)] | | [dB (uV)] | | [dB (uV)] | | (dB) | |
| | | | Q.P. | AV. | Q.P. | AV. | Q.P. | AV. | Q.P. | AV. |
| 1 | 0.17605 | 0.21 | 17.58 | 1.02 | 17.79 | 1.23 | 64.67 | 54.67 | -46.88 | -53.44 |
| 2 | 0.39219 | 0.24 | 29.51 | 9.24 | 29.75 | 9.48 | 58.02 | 48.02 | -28.27 | -38.54 |
| 3 | 0.80945 | 0.29 | 15.30 | 0.46 | 15.59 | 0.75 | 56.00 | 46.00 | -40.41 | -45.25 |
| 4 | 1.39657 | 0.32 | 15.68 | 1.16 | 16.00 | 1.48 | 56.00 | 46.00 | -40.00 | -44.52 |
| 5 | 2.63285 | 0.37 | 16.55 | 1.34 | 16.92 | 1.71 | 56.00 | 46.00 | -39.08 | -44.29 |
| 6 | 5.80386 | 0.46 | 20.83 | 7.10 | 21.29 | 7.56 | 60.00 | 50.00 | -38.71 | -42.44 |

REMARKS:

1. Q.P. and AV. are abbreviations of quasi-peak and average individually.
2. The emission levels of other frequencies were very low against the limit.
3. Margin value = Emission level - Limit value
4. Correction factor = Insertion loss + Cable loss
5. Emission Level = Correction Factor + Reading Value.

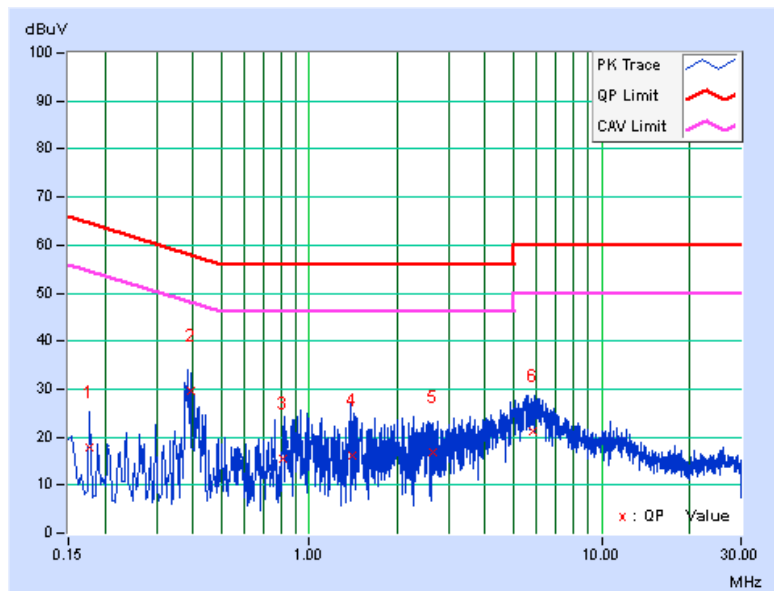

| | | | |
|-----------|--------|---------------|------|
| PHASE | Line 2 | 6dB BANDWIDTH | 9kHz |
| TEST MODE | A | | |

| No | Freq. [MHz] | Corr. Factor (dB) | Reading Value | | Emission Level | | Limit | | Margin | |
|----|----------------|----------------------|---------------|------|----------------|------|-----------|-------|--------|--------|
| | | | [dB (uV)] | | [dB (uV)] | | [dB (uV)] | | (dB) | |
| | | | Q.P. | AV. | Q.P. | AV. | Q.P. | AV. | Q.P. | AV. |
| 1 | 0.17374 | 0.20 | 21.76 | 2.46 | 21.96 | 2.66 | 64.78 | 54.78 | -42.82 | -52.12 |
| 2 | 0.23586 | 0.20 | 21.40 | 1.77 | 21.60 | 1.97 | 62.24 | 52.24 | -40.64 | -50.27 |
| 3 | 0.37304 | 0.22 | 24.03 | 5.43 | 24.25 | 5.65 | 58.43 | 48.43 | -34.19 | -42.79 |
| 4 | 0.88531 | 0.26 | 12.16 | 1.17 | 12.42 | 1.43 | 56.00 | 46.00 | -43.58 | -44.57 |
| 5 | 5.79421 | 0.48 | 20.21 | 8.33 | 20.69 | 8.81 | 60.00 | 50.00 | -39.31 | -41.19 |
| 6 | 10.95333 | 0.64 | 11.83 | 1.64 | 12.47 | 2.28 | 60.00 | 50.00 | -47.53 | -47.72 |

REMARKS:

1. Q.P. and AV. are abbreviations of quasi-peak and average individually.
2. The emission levels of other frequencies were very low against the limit.
3. Margin value = Emission level - Limit value
4. Correction factor = Insertion loss + Cable loss
5. Emission Level = Correction Factor + Reading Value.

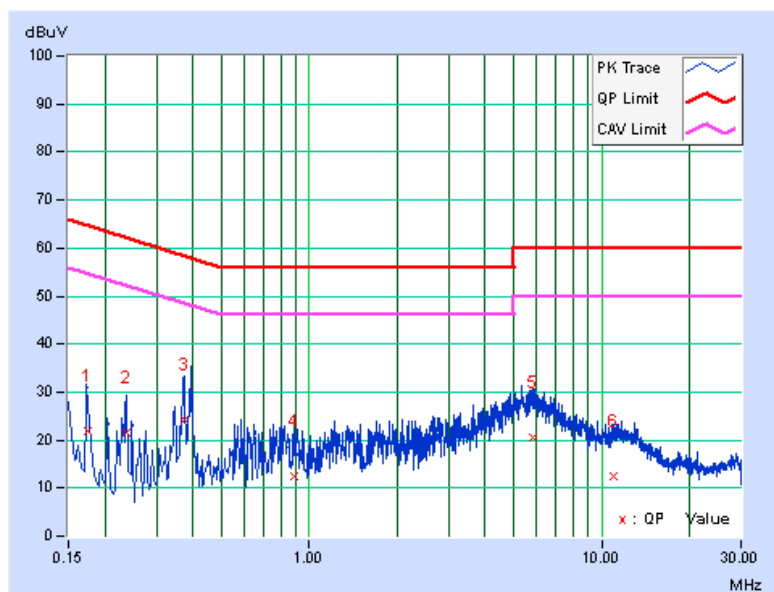

| | | | |
|------------------|--------|----------------------|------|
| PHASE | Line 1 | 6dB BANDWIDTH | 9kHz |
| TEST MODE | B | | |

| No | Freq. [MHz] | Corr. Factor (dB) | Reading Value | | Emission Level | | Limit | | Margin | |
|----------|----------------|----------------------|---------------|--------------|----------------|--------------|--------------|--------------|---------------|--------------|
| | | | [dB (uV)] | | [dB (uV)] | | [dB (uV)] | | (dB) | |
| | | | Q.P. | AV. | Q.P. | AV. | Q.P. | AV. | Q.P. | AV. |
| 1 | 0.17374 | 0.21 | 54.10 | 40.42 | 54.31 | 40.63 | 64.78 | 54.78 | -10.47 | -14.15 |
| 2 | 0.21059 | 0.22 | 46.88 | 32.50 | 47.10 | 32.72 | 63.18 | 53.18 | -16.08 | -20.46 |
| 3 | 0.49324 | 0.25 | 39.95 | 39.29 | 40.20 | 39.54 | 56.11 | 46.11 | -15.91 | -6.57 |
| 4 | 0.99065 | 0.31 | 34.08 | 30.60 | 34.39 | 30.91 | 56.00 | 46.00 | -21.61 | -15.09 |
| 5 | 5.30338 | 0.46 | 29.62 | 24.25 | 30.08 | 24.71 | 60.00 | 50.00 | -29.92 | -25.29 |
| 6 | 12.10287 | 0.58 | 35.81 | 30.49 | 36.39 | 31.07 | 60.00 | 50.00 | -23.61 | -18.93 |

REMARKS:

1. Q.P. and AV. are abbreviations of quasi-peak and average individually.
2. The emission levels of other frequencies were very low against the limit.
3. Margin value = Emission level - Limit value
4. Correction factor = Insertion loss + Cable loss
5. Emission Level = Correction Factor + Reading Value.

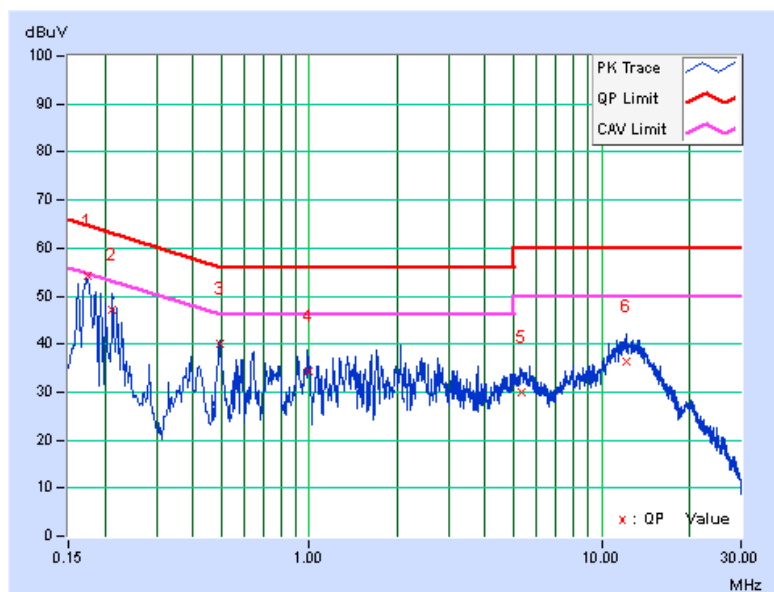

| | | | |
|------------------|--------|----------------------|------|
| PHASE | Line 2 | 6dB BANDWIDTH | 9kHz |
| TEST MODE | B | | |

| No | Freq. [MHz] | Corr. Factor (dB) | Reading Value | | Emission Level | | Limit | | Margin | |
|----|----------------|----------------------|---------------|-------|----------------|-------|-----------|-------|--------|--------|
| | | | [dB (uV)] | | [dB (uV)] | | [dB (uV)] | | (dB) | |
| | | | Q.P. | AV. | Q.P. | AV. | Q.P. | AV. | Q.P. | AV. |
| 1 | 0.16967 | 0.20 | 54.51 | 41.35 | 54.71 | 41.55 | 64.98 | 54.98 | -10.26 | -13.42 |
| 2 | 0.19510 | 0.20 | 47.42 | 33.14 | 47.62 | 33.34 | 63.82 | 53.82 | -16.20 | -20.48 |
| 3 | 0.48678 | 0.23 | 35.16 | 30.40 | 35.39 | 30.63 | 56.22 | 46.22 | -20.84 | -15.60 |
| 4 | 2.12329 | 0.32 | 34.53 | 30.28 | 34.85 | 30.60 | 56.00 | 46.00 | -21.15 | -15.40 |
| 5 | 5.43914 | 0.47 | 29.18 | 23.84 | 29.65 | 24.31 | 60.00 | 50.00 | -30.35 | -25.69 |
| 6 | 12.13806 | 0.67 | 35.32 | 29.96 | 35.99 | 30.63 | 60.00 | 50.00 | -24.01 | -19.37 |

REMARKS:

1. Q.P. and AV. are abbreviations of quasi-peak and average individually.
2. The emission levels of other frequencies were very low against the limit.
3. Margin value = Emission level - Limit value
4. Correction factor = Insertion loss + Cable loss
5. Emission Level = Correction Factor + Reading Value.

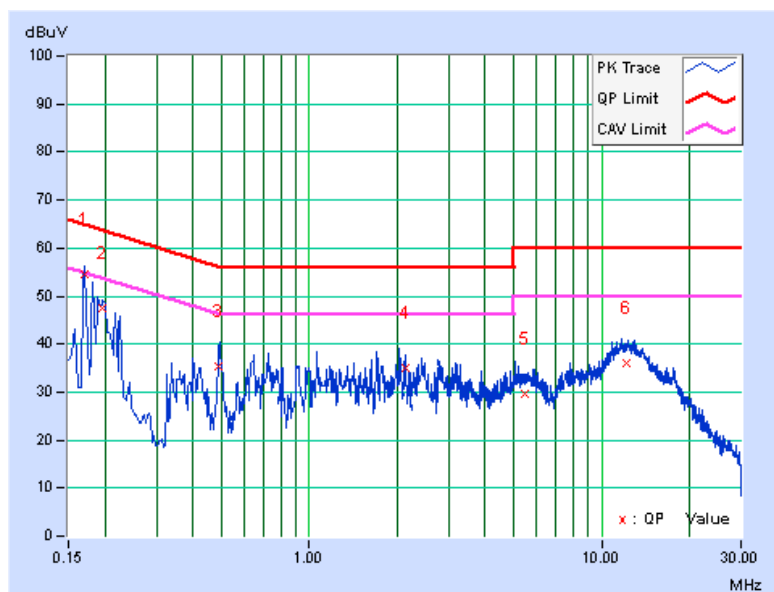

5.3 6dB BANDWIDTH MEASUREMENT

5.3.1 LIMITS OF 6dB BANDWIDTH MEASUREMENT

The minimum of 6dB Bandwidth Measurement is 0.5 MHz.

5.3.2 TEST SETUP

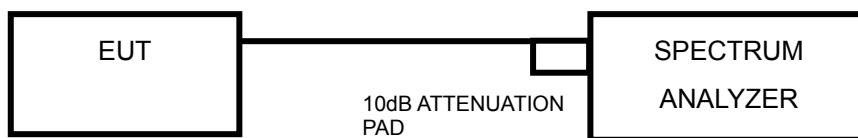

5.3.3 TEST INSTRUMENTS

Refer to section 4.1.2 to get information of above instrument.

5.3.4 TEST PROCEDURE

1. Set resolution bandwidth (RBW) = approximately 1% of the emission bandwidth
2. Set the video bandwidth (VBW) $\geq 3 \times$ RBW, Detector = Peak.
3. Trace mode = max hold.
4. Sweep = auto couple.
5. Measure the maximum width of the emission that is constrained by the frequencies associated with the two amplitude points (upper and lower) that are attenuated by 6 dB relative to the maximum level measured in the fundamental emission.

5.3.5 DEVIATION FROM TEST STANDARD

No deviation.

5.3.6 EUT OPERATING CONDITIONS

The software provided by client to enable the EUT under transmission condition continuously at lowest, middle and highest channel frequencies individually.

5.3.7 TEST RESULTS

| CHANNEL | FREQUENCY (MHz) | 6dB BANDWIDTH (MHz) | MINIMUM LIMIT (MHz) | PASS / FAIL |
|---------|-----------------|---------------------|---------------------|-------------|
| 0 | 2402 | 0.70 | 0.5 | PASS |
| 19 | 2440 | 0.70 | 0.5 | PASS |
| 39 | 2480 | 0.69 | 0.5 | PASS |

5.4 CONDUCTED OUTPUT POWER

5.4.1 LIMITS OF CONDUCTED OUTPUT POWER MEASUREMENT

For systems using digital modulation in the 2400–2483.5 MHz: 1 Watt (30dBm)

5.4.2 TEST SETUP

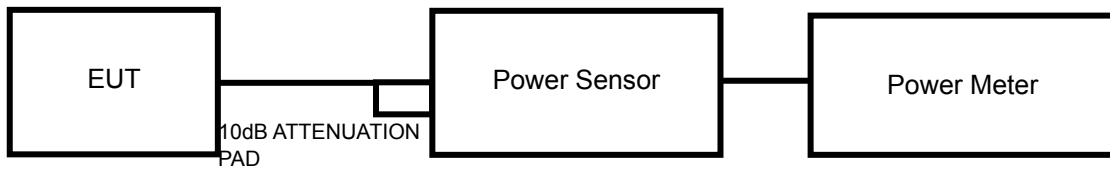

5.4.3 TEST INSTRUMENTS

Refer to section 4.1.2 to get information of above instrument.

5.4.4 TEST PROCEDURES

A peak power sensor was used on the output port of the EUT. A power meter was used to read the response of the peak power sensor. Record the peak power level.

5.4.5 DEVIATION FROM TEST STANDARD

No deviation.

5.4.6 EUT OPERATING CONDITIONS

Same as Item 4.3.6.

5.4.7 TEST RESULTS

| CHANNEL | FREQUENCY (MHz) | PEAK POWER (mW) | PEAK POWER (dBm) | LIMIT (dBm) | PASS/FAIL |
|---------|-----------------|-----------------|------------------|-------------|-----------|
| 0 | 2402 | 4.786 | 6.80 | 30 | PASS |
| 19 | 2440 | 4.819 | 6.83 | 30 | PASS |
| 39 | 2480 | 4.613 | 6.64 | 30 | PASS |

5.5 POWER SPECTRAL DENSITY MEASUREMENT

5.5.1 LIMITS OF POWER SPECTRAL DENSITY MEASUREMENT

The Maximum of Power Spectral Density Measurement is 8dBm.

5.5.2 TEST SETUP

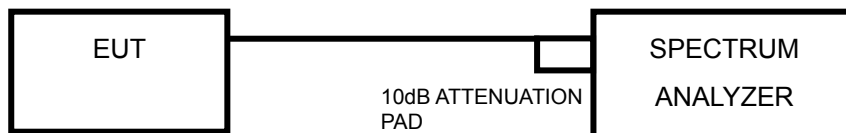

5.5.3 TEST INSTRUMENTS

Refer to section 4.1.2 to get information of above instrument.

5.5.4 TEST PROCEDURE

- Set the RBW = 100 kHz, VBW = 300 kHz, Detector = peak.
- Sweep time = auto couple, Trace mode = max hold, allow trace to fully stabilize.
- Use the peak marker function to determine the maximum power level in any 100 kHz band segment within the fundamental EBW.
- Scale the observed power level to an equivalent value in 3 kHz by adjusting (reducing) the measured power by a bandwidth correction factor (BWCF) where $BWCF = 10\log(3 \text{ kHz}/100\text{kHz})$

5.5.5 DEVIATION FROM TEST STANDARD

No deviation.

5.5.6 EUT OPERATING CONDITION

Same as Item 4.3.6

5.5.7 TEST RESULTS

| Channel | FREQ. (MHz) | PSD (dBm/100kHz) | PSD (dBm/3kHz) | Limit (dBm/3kHz) | PASS /FAIL |
|---------|-------------|------------------|----------------|------------------|------------|
| 0 | 2402 | 6.41 | -8.82 | 8 | PASS |
| 19 | 2440 | 6.44 | -8.79 | 8 | PASS |
| 39 | 2480 | 6.20 | -9.03 | 8 | PASS |

5.6 CONDUCTED OUT OF BAND EMISSION MEASUREMENT

5.6.1 LIMITS OF OUT OF BAND EMISSION MEASUREMENT

Below -20dB of the highest emission level of operating band (in 100kHz Resolution Bandwidth).

5.6.2 TEST SETUP

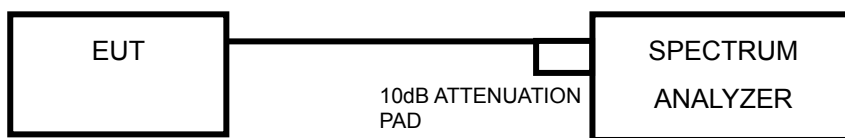

5.6.3 TEST INSTRUMENTS

Refer to section 4.1.2 to get information of above instrument.

5.6.4 TEST PROCEDURE

MEASUREMENT PROCEDURE REF

1. Set the RBW = 100 kHz.
2. Set the VBW \geq 300 kHz.
3. Detector = peak.
4. Sweep time = auto couple.
5. Trace mode = max hold.
6. Allow trace to fully stabilize.
7. Use the peak marker function to determine the maximum power level in any 100 kHz band segment within the fundamental EBW.

MEASUREMENT PROCEDURE OOB

1. Set RBW = 100 kHz.
2. Set VBW \geq 300 kHz.
3. Set span to encompass the spectrum to be examined
4. Detector = peak.
5. Trace Mode = max hold.
6. Sweep = auto couple.

5.6.5 DEVIATION FROM TEST STANDARD

No deviation.

5.6.6 EUT OPERATING CONDITION

Same as Item 4.3.6

5.6.7 TEST RESULTS

The spectrum plots are attached on the following pages. D1 line indicates the highest level, and D2 line indicates the 20dB offset below D1. It shows compliance with the requirement.

5.6.8 TEST RESULTS

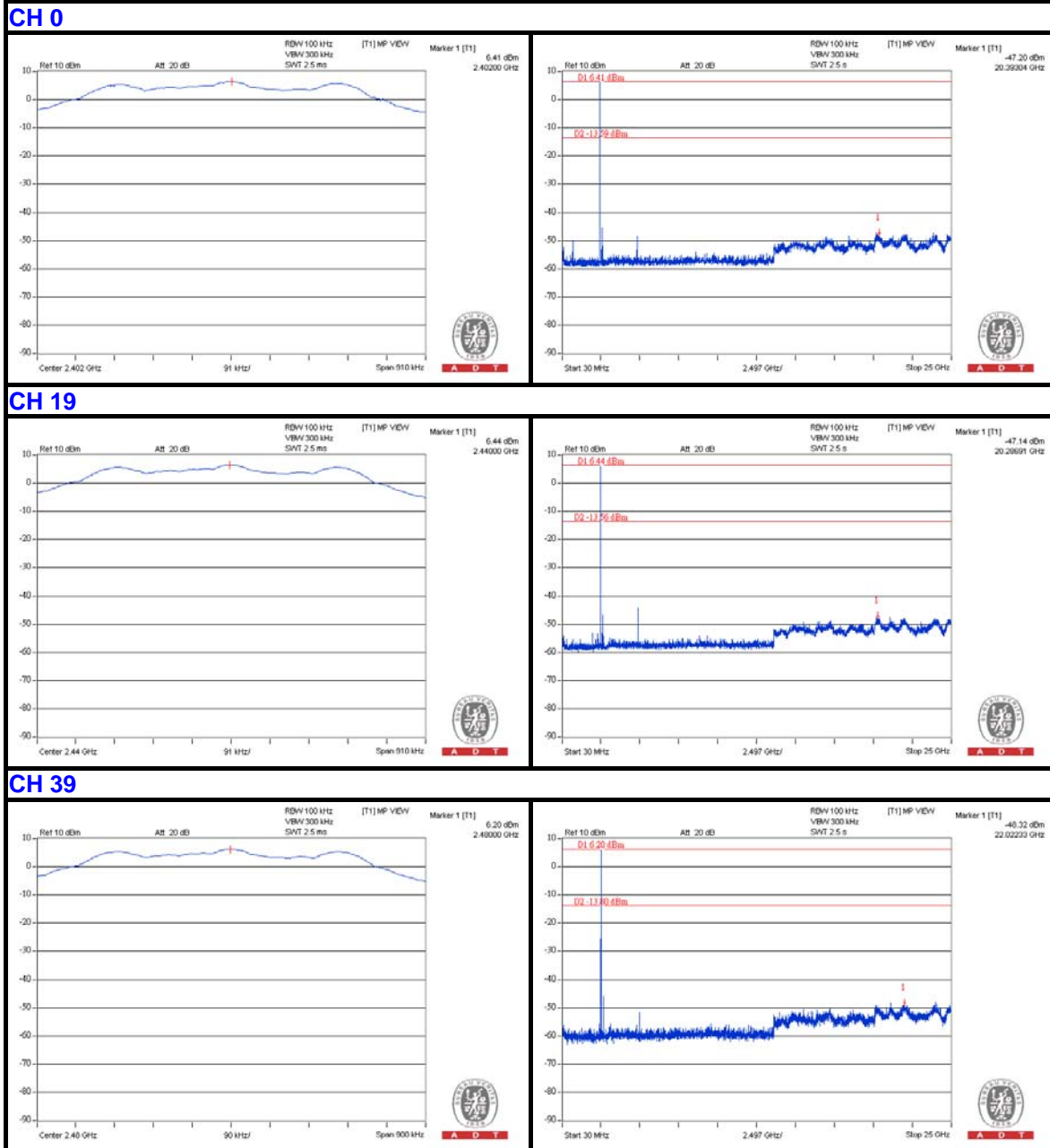



6. PHOTOGRAPHS OF THE TEST CONFIGURATION

Please refer to the attached file (Test Setup Photo).





7. INFORMATION ON THE TESTING LABORATORIES

We, Bureau Veritas Consumer Products Services (H.K.) Ltd., Taoyuan Branch, were founded in 1988 to provide our best service in EMC, Radio, Telecom and Safety consultation. Our laboratories are accredited and approved according to ISO/IEC 17025.

If you have any comments, please feel free to contact us at the following:

Linko EMC/RF Lab:
Tel: 886-2-26052180
Fax: 886-2-26051924

Hsin Chu EMC/RF Lab:
Tel: 886-3-5935343
Fax: 886-3-5935342

Hwa Ya EMC/RF/Safety Telecom Lab:
Tel: 886-3-3183232
Fax: 886-3-3270892

Email: service.adt@tw.bureauveritas.com
Web Site: www.bureauveritas-adt.com

The address and road map of all our labs can be found in our web site also.



8. APPENDIX A – MODIFICATIONS RECORDERS FOR ENGINEERING CHANGES TO THE EUT BY THE LAB

No modifications were made to the EUT by the lab during the test.

--- END ---