

157--00623REF

DO NOT REVISE RASTER FILE
REVISE AGILE VENDOR DOCUMENT

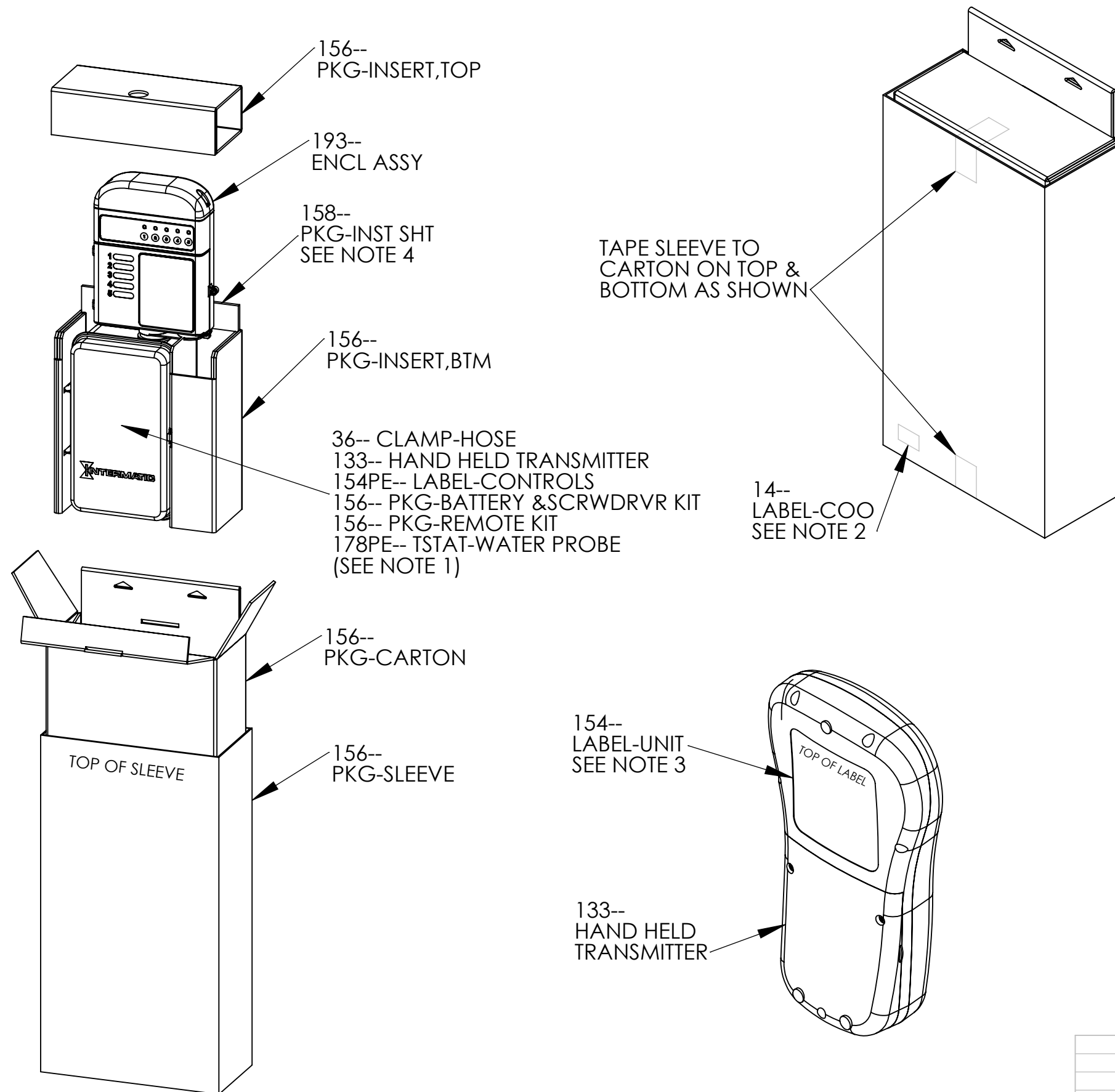

NOTE:

- 1) PACK LOOSE ITEMS INSIDE OF METAL ENCLOSURE. KEEP BUBBLE WRAP AND BAGGIES AROUND MATERIALS AS RECEIVED.
- 2) PLACE COO LABEL ON SLEEVE WHERE INDICATED.
- 3) PLACE UNIT LABEL ON HAND HELD TRANSMITTER AND RE-WRAP IN BUBBLE WRAP BEFORE PLACING INTO METAL HOUSING OF ENCLOSURE ASSEMBLY .
- 4) INSTRUCTION SHEET SHOULD BE BETWEEN ENCLOSURE AND BOTTOM INSERT.

		DRAWN RJN 2-23-10	INTERMATIC INCORPORATED	
		SCALE: 1:6	NAME INSTRUCTS-PKG,PE653RC	
		APPROVED	MAT'L SEE B/M	
2	REMOVED 124-- INSLTR GROMMET, 190D-- BATTERY (QTY 3) AND ADDED 156--01594A PKG-BATTERY & SCRWDVR KIT.	RJN 2-23-10	MM 2-23-10	FINISH NONE
REV	REVISION DESCRIPTION	REVISED	SUPERSEDES	HEAT TREAT NONE
DIMENSIONING SYSTEM: ALL DIMENSIONS ARE IN INCHES UNLESS OTHERWISE SPECIFIED -METRIC DIMS IN BRACKETS IF DUAL DIMENSIONED		TOLERANCES: DECIMALS (UNLESS OTHERWISE SPECIFIED) - TWO PLACE (.00) +/- .015 - THREE (.000) +/- .005 ANGLES +/- 30 MINUTES - ALL DIMENSIONS MUST BE MET BEFORE PLATING		