

193--00281A

DO NOT REVISE RASTER FILE
REVISE AGILE VENDOR DOCUMENT

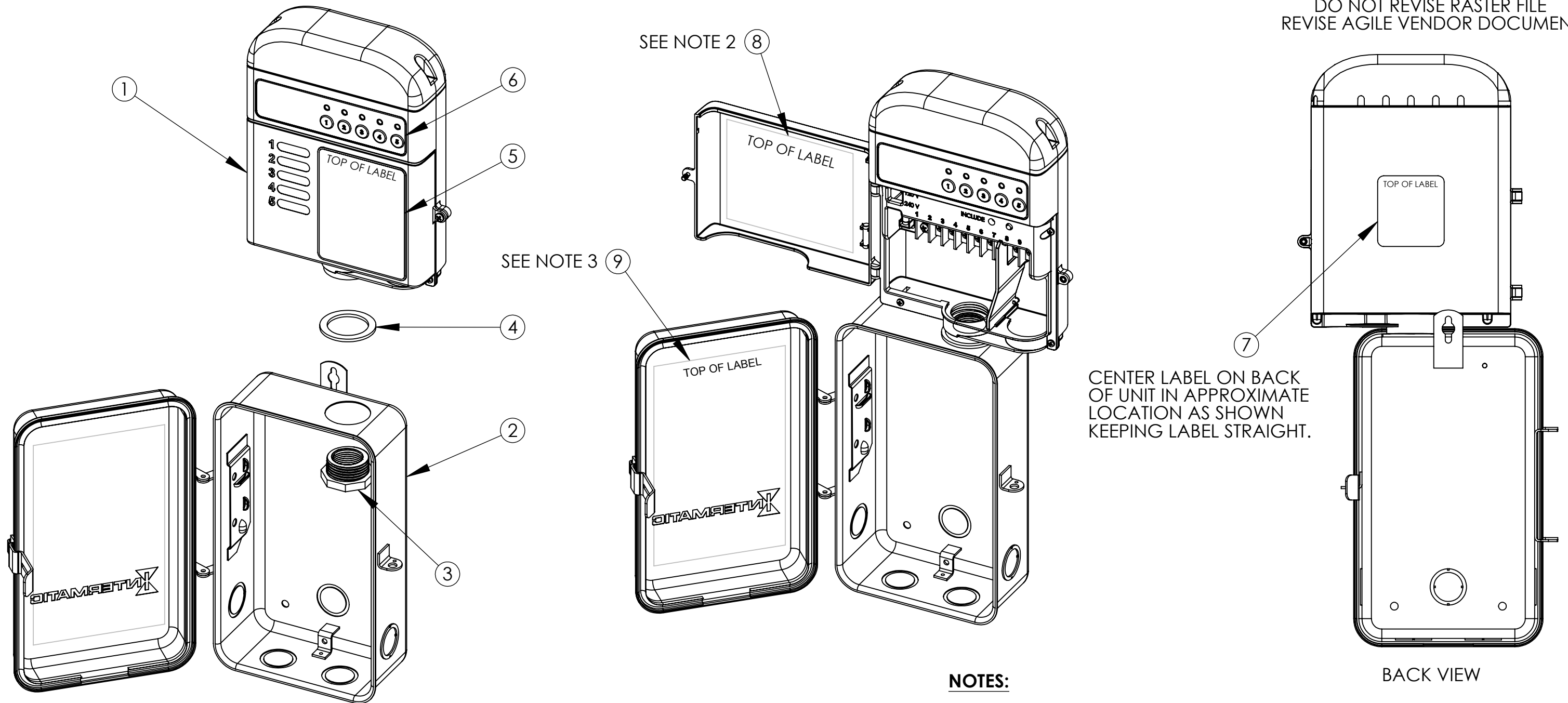

CENTER LABEL ON BACK OF UNIT IN APPROXIMATE LOCATION AS SHOWN KEEPING LABEL STRAIGHT.

BACK VIEW

NOTES:

- 1) SECURE ITEM 1 TIGHTLY TO ITEM 2 USING ITEMS 3 & 4 AS SHOWN.
- 2) OPEN 5-CIRCUIT RECEIVER DOOR AND PLACE ITEM 8 ON INSIDE OF DOOR. THEN RESCREW DOOR SHUT.
- 3) OPEN DOOR ON METAL CASE AND PLACE ITEM 9 ON INSIDE OF DOOR.

		DRAWN RJN 2-23-10	INTERMATIC INCORPORATED
		SCALE: 1:3	
		APPROVED	NAME ENCL ASSY-PE653RC
		MODEL	MAT'L SEE B/M
2	ADDED ITEM 9 AND NOTE 3	RJN 2-23-10	FINISH NONE
REV	REVISION DESCRIPTION	REVISED	HEAT TREAT NONE
DIMENSIONING SYSTEM: ALL DIMENSIONS ARE IN INCHES UNLESS OTHERWISE SPECIFIED -METRIC DIMS IN BRACKETS IF DUAL DIMENSIONED		TOLERANCES: DECIMALS (UNLESS OTHERWISE SPECIFIED) - TWO PLACE (.00) +/- .015 - THREE (.000) +/- .005 ANGLES +/- 30 MINUTES - ALL DIMENSIONS MUST BE MET BEFORE PLATING	