

3M | **PELTOR™**

**Professional In-Ear Communication
Headset, PIC-100 NA**

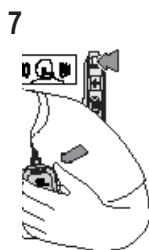

Quick Setup Guide

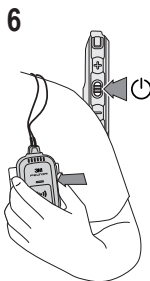
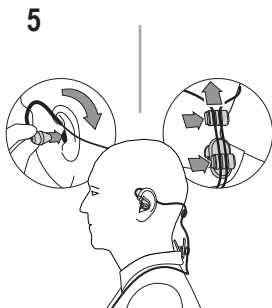
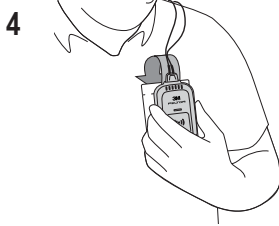
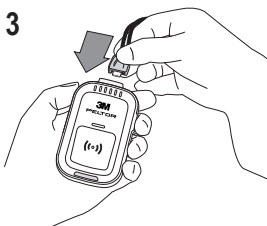
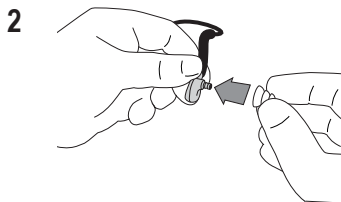
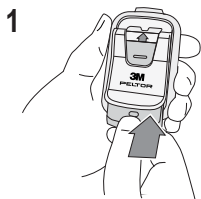



LABORATORY ATTENUATION

U.S. EPA specifies the NRR as the measure of hearing protector noise reduction. However, 3M makes no warranties as to the suitability of the NRR for this purpose. 3M strongly recommends personal fit testing of hearing protectors. Research suggests that users may receive less noise reduction than indicated by the attenuation label value(s) on the packaging due to variation in fit, fitting skill, and motivation of the user. Refer to applicable regulations and guidance on how to adjust attenuation label value(s). It is recommended that the NRR be reduced by 50% to better estimate typical protection.

The attenuation rating (NRR) was obtained with the device powered off.

Standard ANSI S3.19-1974											
	A:A 3M™ Skull Screw™ Communication Eartips 3M™ Skull Screw™ Metal Detectable Communication Eartips										
A:1 Frequency (Hz) (f)	125	250	500	1000	2000	3150	4000	6300	8000	NRR	CSA Class
A:2 Mean Attenuation (dB) (Mf)	41.1	40.5	44.9	43.1	40.6	45.7	44.6	48.2	48.5	33	AL
A:3 Standard deviation (dB) (sf)	6.3	6.0	5.9	4.0	3.4	3.5	4.0	5.1	4.2		

Standard ANSI S3.19-1974											
	A:B 3M™ PELTOR™ CCC-GRM-25 Communication Eartips										
A:1 Frequency (Hz) (f)	125	250	500	1000	2000	3150	4000	6300	8000	NRR	CSA Class
A:2 Mean Attenuation (dB) (Mf)	33.4	34.2	37.3	38.8	38.1	43.3	40.9	45.9	47.1	27	AL
A:3 Standard deviation (dB) (sf)	5.5	6.0	6.4	6.1	3.0	4.1	4.4	4.1	4.4		

Standard ANSI S3.19-1974											
	A:C 3M™ UltraFit™ Communication Eartips										
A:1 Frequency (Hz) (f)	125	250	500	1000	2000	3150	4000	6300	8000	NRR	CSA Class
A:2 Mean Attenuation (dB) (Mf)	34.7	35.4	35.0	32.8	33.0	37.4	30.6	40.9	45.4	21	AL
A:3 Standard deviation (dB) (sf)	6.9	5.1	6.0	5.1	5.2	5.7	6.6	7.9	4.6		

3M™ PELTOR™ Professional In-Ear Communication Headset, PIC-100 NA

EN	1-19
FR	20-39
ES	40-59

3M™ PELTOR™ Professional In-Ear Communication Headset, PIC-100 NA

1. INTRODUCTION

Congratulations and thank you for choosing 3M™ PELTOR™ communication solutions! Welcome to the next generation of protective communication.

1.1. INTENDED USE

The PIC-100 headset with level-dependent hearing protectors help provide hearing protection in noisy environments while enabling environmental listening in quiet environments, listening to connected communication devices, and communicating face-to-face with integrated close-connect technology in high levels of steady state noise. PIC-100 headset also offers a real-time fit test. It is expected that all users read and understand the provided user instructions as well as be familiar with the use of this device.

2. SAFETY

2.1. IMPORTANT

Please read, understand, and follow all safety information in these instructions prior to use. Retain these instructions for future reference. For additional information or any questions, contact 3M Technical Services. Refer to contact information listed on the last page of this manual.

WARNING

This hearing protector helps reduce exposure to hazardous noise and other loud sounds. Misuse or failure to wear hearing protection at all times when exposed to hazardous noise may result in hearing loss or injury. For correct use, consult supervisor and User Instructions, or call 3M Technical Services. If your hearing seems dulled or you hear a ringing or buzzing during or after any noise exposure (including gunfire), or for any other reason you suspect a hearing problem, leave the noisy environment immediately and consult a medical professional and/or your supervisor.

Failure to follow these instructions may result in serious injury or death:

- Choking hazard – keep away from infants and small children.
- If there is any drainage from your ear or you have an ear infection, consult a medical professional before wearing earplugs.
- Listening to audio communication may reduce your situational awareness and ability to hear warning signals. Stay alert and adjust the audio volume to the lowest acceptable level.
- To reduce the risks associated with igniting an explosion, do not use this product in a potentially explosive atmosphere.

Failure to follow these instructions may reduce the protection provided by the earplug and may result in hearing loss:

- U.S. EPA specifies the NRR as the measure of hearing protector noise reduction. However, 3M makes no warranties as to the suitability of the NRR for this purpose. 3M strongly recommends personal fit testing of hearing protectors. Research suggests that users may receive less noise reduction than indicated by the attenuation label value(s) on the packaging due to variation in fit, fitting skill, and motivation of the user. Refer to applicable regulations and guidance on how to adjust attenuation label value(s). It is recommended that the NRR be reduced by 50% to better estimate typical protection.
- Ensure the hearing protector is properly selected, fit, adjusted, and maintained. Improper fit of this device will reduce its effectiveness in attenuating noise. Consult the enclosed instructions for proper fit.
- Inspect the hearing protector before each use. If damaged, select an undamaged hearing protector or avoid the noisy environment.
- The output of the electrical audio circuit of this hearing protector may exceed the daily limit sound level. Adjust the audio volume to the lowest acceptable level. Sound levels from any connected external device such as 2-way radios and phones may exceed safe levels and must be appropriately limited by the user. Always use external devices at the lowest sound level possible for the situation and limit the amount of time you are exposed to unsafe levels as determined by your employer and applicable regulations. If your hearing seems dulled or you hear a ringing or buzzing during or after any sound exposure, or for any other reason you suspect a hearing problem, go to a quiet environment immediately and consult a medical professional and/or your supervisor.
- Only use approved and compatible 3M™ PELTOR™ Communication Eartips and hearing protectors.
- If the requirements above are not adhered to, the protection afforded by the hearing protectors will be severely impaired.

2.2. CAUTION

- Risk of explosion if battery is replaced by incorrect type.
- Do not charge battery in temperatures above 30°C/86°F or below 10°C/50°F.
- With lithium ion batteries, there is a risk of fire and burns. Do not open, crush, heat above 50°C/122°F, or incinerate.
- For greater comfort and safety when using the three-flange 3M™ UltraFit™ Communication Eartips, remove the eartip slowly with twisting motion to gradually break the seal.
- Always use product-specific 3M replacement parts. Use of unauthorized replacement parts may reduce the protection you receive from this product.
- Obey the instructions given in this manual. Tampering with the product might void the IP54-approval of this product.
- Dust protected and water resistant when worn properly.



2.3. NOTE

- When worn according to these User instructions, this hearing protector helps reduce exposure to both continuous noises, such as industrial noises and noises from vehicles and aircraft, as well as very loud impulse noises, such as gunfire. It is difficult to predict the required and/or actual hearing protection obtained during exposure to impulse noises. To learn more about hearing protection for impulse noise, visit www.3M.com/hearing.
- This earplug is provided with level-dependent attenuation. The wearer should check correct operation before use. If distortion or failure is detected, the wearer should refer to the manufacturer's advice for maintenance and replacement of the battery in the control unit (SCU).
- This earplug is provided with safety related audio input. The user should check correct operation before use. If distortion or failure is detected, the user should refer to the manufacturer's advice.
- If using an external power supply for charging the SCU, only connect to a listed power supply certified to IEC/UL/CSA 62368-1 or an equivalent local safety standard. The power supply shall have a rated output of 5 VDC, 500 mA (minimum).
- Do not use a splitter cable for charging.

2.4. U.S. EPA REQUIRED STATEMENTS

Improper fit of this device will reduce its effectiveness in attenuating noise. Consult the enclosed instructions for proper fit.

Although hearing protectors can be recommended for protection against the harmful effects of *impulsive* noise, the Noise Reduction Rating (NRR) is based on the attenuation of *continuous* noise and may not be an accurate indicator of the protection attainable against *impulsive* noise such as gunfire.

The level of noise entering a person's ear, when the hearing protector is worn as directed, is closely approximated by the difference between the A-weighted environmental noise level and the NRR.

Example:

1. The environmental noise level as measured at the ear is 92 dB(A).
2. The NRR is 21 decibels (dB).
3. The level of noise entering the ear is approximately equal to 71 dB(A).

CAUTION: For noise environments dominated by frequencies below 500 Hz the C-weighted environmental noise level should be used.

3. FCC AND IC INFORMATION

This device complies with Part 15 of the FCC rules and Industry Canada's license-exempt Radio Standards Specifications. Operation is subject to the following two conditions: (1) This device may not cause harmful interference, and (2) this device must accept any interference received, including interference that may cause undesirable operation.

NOTE: Changes or modifications not expressly approved by the manufacturer could void the user's authority to operate the equipment.

This equipment has been tested and found to comply with the limits for a Class B digital device, pursuant to part 15 of the FCC Rules. These limits are designed to provide reasonable protection against harmful interference in a residential installation. This equipment generates, uses and can radiate radio frequency energy and, if not installed and used in accordance with the instructions, may cause harmful interference to radio communications. However, there is no guarantee that interference will not occur in a particular installation. If this equipment does cause harmful interference to radio or television reception, which can be determined by turning the equipment off and on, the user is encouraged to try to correct the interference by one or more of the following measures:

- Reorient or relocate the receiving antenna.
- Increase the separation between the equipment and receiver.
- Connect the equipment into an outlet on a circuit different from that to which the receiver is connected.
- Consult the dealer or an experienced radio/TV technician for help.

CAN ICES-3 (B)/NMB-3(B)

FCC ID: DGFPSDPIC100NA
IC: 458A-PSDPIC100NA

4. PERFORMANCE STATEMENT (PER ANSI/ASA S12.71-2018)

PIC-100 headset complies with the requirements of ANSI/ASA S12.71-2018. The information in this table is provided to meet compliance requirements for Field Attenuation Estimation Systems (FAES) that report a Personal Attenuation Rating (PAR) according to ANSI/ASA S12.71-2018 *American National Standard Performance Criteria for Systems that Estimate the Attenuation of Passive Hearing Protectors for Individual Users*.

	Specification	Descriptor
A	Manufacturer	3M Company.
B	FAES brand name	3M™ PELTOR™ Professional In-Ear Communication Headset, PIC-100.
C	System requirements	PIC-100 headset and eartips.
D	HPDs supported	3 sizes of eartips: <ul style="list-style-type: none"> • 3M™ UltraFit™ Communication Eartips, • 3M™ Skull Screw™ Communication Eartips/3M™ Skull Screw™ Metal Detectable Communication Eartips • 3M™ PELTOR™ CCC-GRM-25 Communication Eartips.
E	FAES test method	Field-Microphone in Real Ear (F-MIRE) with standard HPD.
F	FAES type	Physical using standard HPD.

	Specification	Descriptor
G	Recommended regular physical calibration	Replace with new calibrated headset at least every two years.
H	Recommended periodic verification procedure	Daily check procedure recommended prior to conducting fit test.
I	Maximum permissible ambient noise	103 dB(A) or 109 dB(C).*
J	Minimum and maximum measurable attenuation values	Able to measure PARs ranging from 3 to 43 dB.*
K	Fit-Test Output	User receives audio voice prompt providing PAR ₃₀ + eartip style. Connected app display provides PAR ₃₀ and uncertainty value.
L	FAES measurement uncertainty (+/-)	(Pre-molded) earplugs: 6 dB Push to fit foam earplugs: 3 dB.*
M	Listener requirements	No requirements. All listeners can participate regardless of hearing ability.

*NOTE: These values are applicable for firmware version v2.17.1. Always refer to the most current user instructions for the firmware version and corresponding values, which can be found in the 3M Connected Equipment app under the Support section when connected to a PIC-100.

5. LABORATORY ATTENUATION

5.1. EXPLANATION OF LABORATORY ATTENUATION TABLES

A:A	3M™ Skull Screw™ Communication Eartips 3M™ Skull Screw™ Metal Detectable Communication Eartips
A:B	3M™ PELTOR™ CCC-GRM-25 Communication Eartips
A:C	3M™ UltraFit™ Communication Eartips
A:1	Frequency (Hz) (<i>f</i>)
A:2	Mean attenuation (dB) (Mf)
A:3	Standard deviation (dB) (sf)

6. OVERVIEW

6.1. IN-EAR HEADSET OVERVIEW

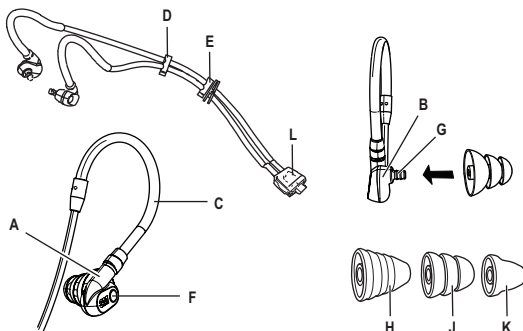

- A * Earplug
- B Earpiece (PC/ABS plastic)
- C Earhook (SEBS TPE)
- D Cable slider
- E Cable clip
- F Environmental microphone
- G Eartip stem (ABS plastic)
- H Eartip – Skull Screw™ Communication Eartips (Urethane foam)

- J Eartip – UltraFit™ Eartips (SEBS TPE)
- K Eartip – CCC Eartips (Urethane foam)
- L Control unit connector

* NOTE: When an earpiece is fully assembled with eartip on, it will be referred to as an earplug. When the earpiece does not have eartip on, it will be referred to as an earpiece.

6.2. SYSTEM CONTROL UNIT (SCU) OVERVIEW

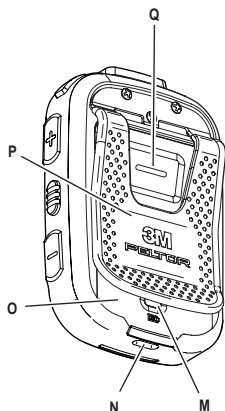
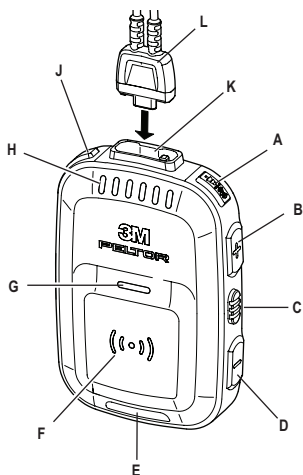

A Fit test/channel button

B (+) button

C Power/menu button

D (-) button

E Tether loop

F Push-to-talk button

G Status light

close-connect status and VOX status

H Channel lights

Indicates current channel, volume level and fit result

J Bluetooth® button

K In-ear headset connector

L Headset socket connection

M Battery status indicator (LED)

N USB-C® socket for battery charging

O Removable battery with integrated USB-C® charging port

P SCU clip

Q Battery grip





6.3. STATUS AND CHANNEL LIGHTS

6.3.1. GENERAL

The indicator lights are used to present status of functions and procedures.

A light can be off, on or blinking and can have different colors.

6.3.2. LED INDICATOR LIGHT DESCRIPTIONS

LED Indicator lights in illustrations	Description
	Off.
	On (dimmed light).
	On (white).
	On (color).

7. EXPLANATION OF SYMBOLS



Recycling Symbol. Recycle this product at a recycling station for electrical and electronic equipment.

NOTE: Other symbols/decals may occur on the product due to certification requirements for some commercial areas.

8. SETUP

8.1. GENERAL

The following point covers the main actions to make the PIC-100 headset ready for operation. Follow instructions provided in chapter 8.2, chapter 9 and chapter 10.

- Check battery status
Charge or replace the battery if required
- Prepare the earplugs
Select and fit appropriate earplugs
- Connect the headset to the SCU
- Attach the SCU
- Fit the earplugs and adjust earhooks
Adjust the cable
- Power on the SCU
- Carry out a real-time fit test

8.2. BATTERY

8.2.1. GENERAL

The figure below shows battery pack removed from the SCU.

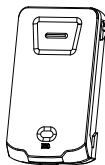

The PIC-100 Battery should be charged before first use. The product will indicate low battery status with an audio message 'low battery', when less than one hour of battery life remains. The audio message will repeat every five minutes.

Charging shall be done by means of a USB cable or in an optional 3M™ PELTOR™ PIC-100 Charging Station.

8.2.2. REMOVE/INSTALL BATTERY PACK

Remove battery pack

1. Turn the SCU over so that the SCU clip is facing up.
2. Slide the battery out from the bottom of the SCU by pushing on the grips (1) located in the SCU clip window.
3. Lift the SCU clip slightly if needed.

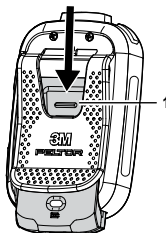

Install battery pack

1. Lift the SCU clip (1) slightly and align the sides of the battery pack with the grooves of the SCU.
2. Slide the battery pack into the back of the SCU firmly until you hear and feel a click.

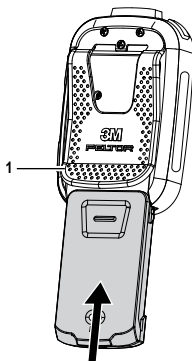

8.2.3. CHARGING

1. Connect the USB-C® connector to the battery socket (1).
2. Connect the other USB-C® connector to a USB power source.
3. Battery LED indicator (2) shows status of the battery. (Functions only when USB-C® cable is connected to power.)
 Red = Charging
 Green = Fully charged
 Off = Out of recommended charging temperature
 (See section 2.2.)

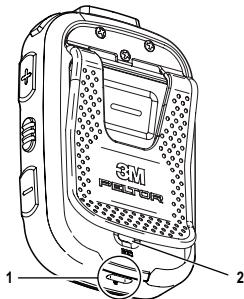

NOTE: Only connect to a listed power supply certified according to IEC/UL/CSA 62368-1 or an equivalent local safety standard. The power supply shall have a rated output of 5 VDC, 500 mA (minimum).

9. DAILY CHECK

9.1. DAILY CHECK ENVIRONMENT

The daily check function should be performed prior to conducting a fit test to verify that the microphones in the earpieces are in working order. The daily check must be performed with the headset connected to the SCU in a suitable sound environment, without communication earbuds attached and while NOT being worn.

A suitable sound environment is defined as an environment where there is a moderate amount of noise in the vicinity during the daily check. Examples are: cafeteria or break room where several people are talking; a single person speaking into the earpieces from at least one meter (approximately 3 ft) away, music from a radio, car audio, or loudspeaker; machinery sounds heard from a safe distance not requiring hearing protection; sound of cars traveling on a busy street.

Unsuitable environments include: windy environments, quiet environments, hazardous noise environments where hearing protection is required; earpieces that are too close to the sound source.

9.2. DAILY CHECK PROCEDURE

Remove any communication earbuds from the earpiece. Attach the headset to the SCU as described in 10.3. ATTACH THE SCU. If the SCU is not already powered on, press and hold the Power/Menu button for 5 seconds to turn the unit on as described in 11.2. POWER ON AND OFF.

Hold the earpieces by the earhooks about 2.5 cm/1 inch away from the earpieces. Figure A. Make sure that the earpieces are held still. Alternatively, place the earpieces on a non-movable, flat surface as shown in Figure B.

Figure A

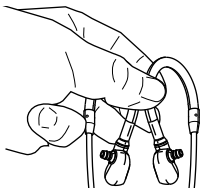
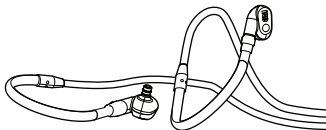
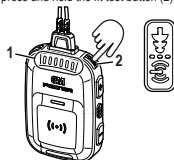







Figure B



To start the daily check, press and hold the fit test button (2) for 6 seconds or more.



The daily check procedure begins and can be observed by the white channel light indicators (1) described below. The process takes about 5 seconds.

LED indicators	Description	What to do
All LEDs are blinking white 	Daily check is running. White lights blinking.	No action required.
All LEDs lit green 	Daily check is successful on both left and right earpieces.	No action required. Microphones are functioning properly.
A = Green B = Red 	Daily check failure on left earpiece. Red (B) LEDs illuminate.	Ensure the environment is suitable to conduct the test, remove any debris from the earpiece stem or from around the microphone cover and repeat daily check.
A = Red B = Green 	Daily check failure on right earpiece. Red (A) LEDs illuminate.	Ensure the environment is suitable to conduct the test, remove any debris from the earpiece stem or from around the microphone cover and repeat daily check.
All LEDs lit Red 	Daily check failure on both left and right earpieces. Red LEDs illuminate.	Ensure the environment is suitable to conduct the test, remove any debris from the earpiece stem or from around the microphone cover and repeat daily check.

10. FITTING INSTRUCTIONS

Inspect the hearing protector before each use. If damaged, select an undamaged hearing protector or avoid the noisy environment.

10.1. PREPARE THE EARPLUGS

Select the correct size of the earplug

The packaging includes 3 sizes of 3M™ UltraFit™ Communication Earplugs (small, medium and large), 1 pair of 3M™ Skull Screw™ Communication Earplugs and 1 pair of 3M™ PELTOR™ CCC-GRM-25 Communication Earplugs.

3M™ UltraFit™ Communication Earplugs

- To choose the appropriate 3M™ UltraFit™ earplug size, begin with the medium size.
- Ensure that it is small enough to penetrate the ear canal and provide a secure fit, but also large enough that at least one flange seals the ear canal at the canal entrance.
- If the medium size does not provide a proper fit, proceed with the small or large size earplugs as these were designed to fit users for whom the medium size is not suitable.

3M™ Skull Screw™ Communication Earplugs and 3M™ PELTOR™ CCC-GRM-25 Communication Earplugs

With the 3M™ Skull Screw™ and 3M™ PELTOR™ CCC-GRM-25 Earplugs, one size is intended to fit most.

WARNING! Do not use product if the proper size and fit cannot be obtained.

CAUTION: Use only 3M™ PELTOR™ Earplugs designed for use with this product. Do not insert the earpiece directly into the ear without a correctly attached 3M™ PELTOR™ Earplug.

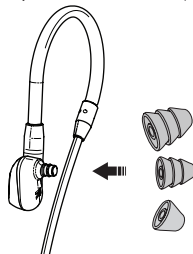

Attaching the earplugs

NOTE: Make sure to handle the earplugs with clean hands.

- Push earplug onto the earplug stem.

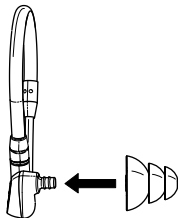

2. Fully seat the eartip at the base of the earplug stem.

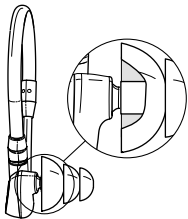

3. Repeat for the second earpiece.

10.2. CONNECT THE HEADSET TO THE SCU

Align and connect the headset connector to the socket in the SCU.

Observe that the connector must be inserted so the keys fit, (a) and (b).

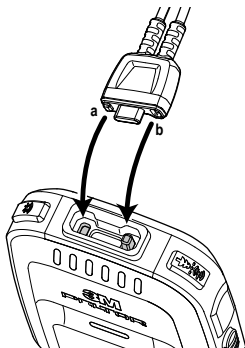

10.3. ATTACH THE SCU

The SCU (1) is to be placed somewhere within the chest area. Preferably fixed to clothing by means of the clip on the back of the SCU.

Position the headset cable on your left or right shoulder until fitting of the earplug begins. See chapter 10.4. FIT THE EARPLUGS AND ADJUST EARHOOKS.

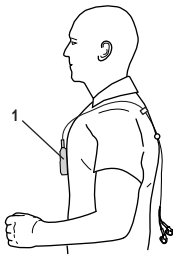

10.4. FIT THE EARPLUGS AND ADJUST EARHOOKS

NOTE: Make sure the earplugs are clean and without damage before inserting them into the ear canal.

1. Select a proper earplug size for your ear canal. Refer to chapter 10.1. PREPARE THE EARPLUGS on page 7.
2. Hold the earplugs so the cables are positioned on one of your shoulders as shown in the illustration below.



3. Grab the left and right earplugs with the corresponding hand and then place them on the left and right shoulder, respectively, so the cable slider and cable clip are positioned behind your neck.



NOTE: Make sure to put the earplug marked "R" into your right ear and the earplug marked "L" into your left ear. The marking is found on the earpiece stem side.

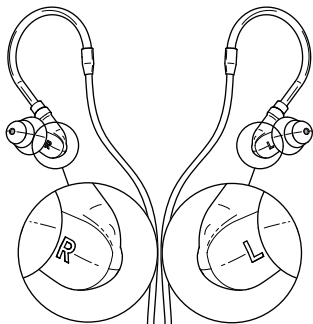

4. Place the earhooks over each ear (left earplug earhook over left ear and right earplug earhook over right ear).

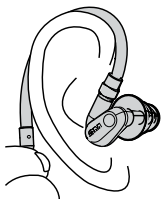

NOTE: Earhooks are shipped in a preformed shape like above. You may need to adjust the shape before placing them on your ears.

This description begins with the right ear.

5. Grasp the earpiece. Insert the rounded eartip into ear canal while pulling the ear outward away from the head and upward with the opposite hand. TWIST while inserting for best noise reduction.



CAUTION: Hearing protection and radio communication performance of the device depends on the proper insertion of the earplugs into the correct ear.

6. Mold the earhook gently around the back of your ear until it feels comfortable and secure. If needed, adjust the earplug to ensure best noise reduction.



7. Repeat this procedure for the left ear.

8. Adjust the cable slider (1) to the back of your head to ensure a snug fit.

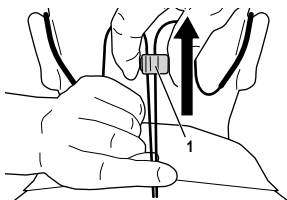

9. Secure the cable clip (1) to the center back of your shirt collar.

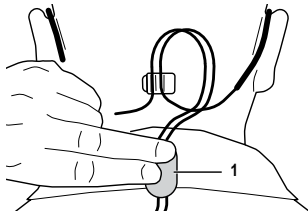

10. **NOTE:** Leave enough slack in the cable to allow you to turn our head fully in both directions without any resistance from the wires.

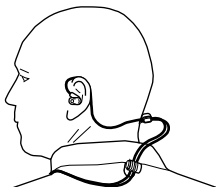

Check to ensure you have a good eartip fit:

- Gently pull the earplugs outward. They should not come out of the ear easily. If they do, repeat insertion.
- Listen to steady loud noise with earplugs in both ears. When a proper fit is obtained, environmental noises should seem substantially quieter in both ears.
- Cover ears with tightly cupped hands. Noise should sound about the same whether or not ears are covered.
- Perform a real-time fit test as described in chapter 11.3. **CARRY OUT A REAL-TIME FIT TEST.**

NOTE: If you cannot obtain a good fit, try a different eartip type or size.

CAUTION: For greater comfort and safety when removing the three flange 3M™ UltraFit™ Communication Eartips, use a slow twisting motion to gradually break the seal.



The PIC-100 headset features an in-ear speech microphone and thus eliminates the need for a traditional boom microphone.

NOTE: Outbound radio transmissions may be degraded if the selected eartip is not correctly fitted in the ear canal.

11. INSTRUCTIONS FOR OPERATION

11.1. OPERATING TEMPERATURE

-20°C/-4°F to 45°C/113°F.

11.2. POWER ON AND OFF

- To power on the SCU, press and hold the Power/Menu button for a minimum of 5 seconds. Headset must be connected to the SCU to power on.



The indicators will animate from inside to outside for the duration of the start-up.



The earplugs will indicate that product is on with audio message "Power on".

- Repeat the same action to power off. The indicators will animate from outside to inside for the duration of the power off. The earplugs will indicate that product is shutting down with audio message "Power off".



The SCU will power off automatically after a pre-set time. Default time is 2 hours but can be adjusted in the menu.

11.3. CARRY OUT A REAL-TIME FIT TEST

Conduct a real-time fit test only if the headset has successfully passed the procedures described in 9.2. DAILY CHECK PROCEDURE.

NOTE: Both earplugs must be fitted before performing a real-time fit test. Noise must be present when test is performed.

For example, fit test in an area that requires hearing protection or where you need to raise your voice to be heard by a person who is at least an arms-length away.

Be sure not to talk or chew while the fit test is being performed.

The first time a real-time fit test is performed, you will be prompted to select the earplugs you have attached to the earpieces.

Audio message: "Please select an earplug type through the menu before conducting a fit test". Each time the earplug type is changed, the type must be updated within the Earplug selection menu.

Use the Power/Menu button to cycle through the menu options until you hear the audio message "Earplug selection - (Unknown, Skull Screw, UltraFit, etc.)". Use (+) or (-) buttons to cycle through the options to choose/change the earplug you intend to use. The audio prompt will identify the earplug selected and is saved automatically.

Press the Power/Menu button again to return to the menu options. After 2 seconds of non-activity, you will be brought back out of the menu.

The SCU will show the real-time fit test progress and result by means of the indicators (1).

To start a real-time fit test:

Press and hold the Fit test/channel button (2) for 1 second. Release when you hear a beep.

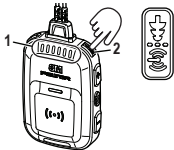

The real-time fit-test process begins and can be observed by the white channel light indicators as described below.

LED indicators	Description	What to do
	Real-time fit test is running. Audio message: "Fit test in progress".	No action required.

LED indicators	Description	What to do
<p>A and B = White</p>	<p>Real-time fit test successful. Able to report a result for both ears.</p> <p>Audio message: "PAR value + earplug type".</p> <p>Audio message when headset calibration has expired: "PAR value + earplug type + calibration status expired."</p> <p>Audio message when unable to assess the calibration status: "PAR xx dB <earplug type> calibration status unknown".</p>	<p>No action required.</p> <p>Replace with new calibrated headset. See 12.14 Calibration Status for more information.</p> <p>Contact 3M Technical Assistance.</p>
<p>A= Orange, B=White</p>	<p>Real-time fit test unsuccessful for right ear. Unable to report a result.</p> <p>Audio message: "PAR out of range (low). Refit right earplug and retest."</p> <p>"PAR out of range (high) Check earplugs and retest."</p>	<p>Refit right earplug and retest.</p> <p>Check or refit right earplug, refit and try again.</p>
<p>A= White, B=Orange</p>	<p>Real-time fit test unsuccessful for left ear. Unable to report a result.</p> <p>Audio message: "PAR out of range (low). Refit left earplug and retest."</p> <p>"PAR out of range (high) Check earplugs and retest."</p>	<p>Refit left earplug and retest.</p> <p>Check or refit left earplug, refit and try again.</p>
<p>A and B = Orange</p>	<p>Real-time fit test unsuccessful for both ears. Unable to report a result.</p> <p>Audio message: "PAR out of range (low). Refit both earplugs and retest."</p> <p>"PAR out of range (high) Check earplugs and retest."</p>	<p>Refit both earplugs and retest.</p> <p>Check or replace both earplugs, refit and try again.</p>

LED indicators	Description	What to do
All LEDs are blinking orange 	Real-time fit test error. Audio messages: "Noise level too low. Retest in more noise." "Noise level too high. Retest in less noise." "Test conditions inadequate". "Fit test error, try again".	Retest in area with higher noise level. Retest in area with lower noise level. Retest where background noise includes a wider range of frequencies from low to high pitches. Retest.

11.4. CHANNEL SELECTION

The PIC-100 headset provides 6 different 2-way radio channels.

Current selected channel is displayed in white by the indicators (1-6) as showed in the figure below. Number 4 is illuminated in this figure.

Quick press the Fit test/channel button to cycle through the channels. While changing the channel, the LED will illuminate at full brightness. The chosen channel LED will stay at full brightness for 2 seconds, then the brightness will reduce by half.

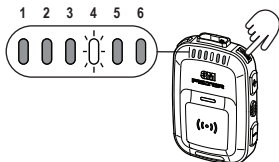

11.5. ADJUST ENVIRONMENTAL LISTENING VOLUME

When powered on, the earpieces allow sounds to pass through in quiet environments while restricting the volume level in loud environments. Upon power on, the PIC-100 headset defaults to the user's previous settings.

The volume controls (+ and -) on the SCU adjust the environmental listening volume if no other streaming or communications are active.

Adjust the volume as described below:

Each quick press adjusts volume by one step (0-6 steps where 0 is off).

1. Make sure the product is on.
2. Press the (+) button to increase environmental volume and the (-) button to decrease environmental volume.
The volume change is indicated with the volume indicators (1).



Volume level for environmental listening is indicated with green color.

When your volume is at zero, channel light 1 turns red.



An audio message will announce each volume level.

11.6. ADJUST RADIO AND BLUETOOTH® VOLUME

The incoming communication volume (radio or Bluetooth®) can be adjusted by means of the volume controls (+ and -) on the SCU when the respective communication is active.

Adjust the volume as described below:

Each quick press adjusts volume by one step (0-6 steps where 0 is off).

By holding the button pressed, the volume steps are repeated.

Press the (+) button to increase volume and the (-) button to decrease volume.

The volume change is indicated with the volume indicators (1).



Volume level for radio is indicated with orange color.

Volume level for Bluetooth® is indicated with blue color.



When your volume is at zero, channel light 1 turns red.

An audio message will announce each volume level.

11.7. BLUETOOTH® FUNCTIONS

Use the Bluetooth® button (1) to handle Bluetooth® functions.

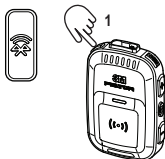

11.7.1. INCOMING CALL

Answer: Quick press on the Bluetooth® button.

Reject: Long press on the Bluetooth® button.

Audio message	Indicators
A ringing sound is played until a call is accepted or rejected.	The channel LEDs sweep left to right repeatedly in blue until a call is answered or rejected. 

11.7.2. ONGOING CALL

Hang up: Long press on the Bluetooth® button.

Audio message	Indicators
A hang-up tone is played.	Blue channel LED activity stops, returns to single active channel LED in white. 

11.7.3. PLAYBACK CONTROL

Play/Pause: Short press on the Bluetooth® button.

Skip Forward: Double click the Bluetooth® button.

Skip Backward: Triple click the Bluetooth® button.

11.7.4. VOICE ASSISTANT

Voice Assistant: Press and hold Bluetooth® button for 1 second. Release when you hear a beep.

11.7.5. BLUETOOTH® MULTIPOINT TECHNOLOGY

PIC-100 headset is designed with Bluetooth® Multipoint technology to connect two Bluetooth® devices at the same time. Depending on the type of Bluetooth® device connected and their current activity, PIC-100 headset controls the Bluetooth® devices in different ways. PIC-100 headset prioritizes and coordinates activities from the connected Bluetooth® devices.

PIC-100 headset can be connected to:

- a single Bluetooth®-enabled smartphone or tablet
- two Bluetooth®-enabled smartphones or tablet
- one Bluetooth®-enabled two-way radio

If two smartphones are connected to PIC-100 headset, a call can be placed or received on either phone.

If PIC-100 headset is connected to a two-way radio, it will act as if a call is always active, regardless of the two-way radio's transmission/reception status. In this mode, PIC-100 headset cannot be connected to another phone or another two-way radio simultaneously. PIC-100 headset will ring when connected to a two-way radio as if it is receiving a call. Simply answer the incoming call by short pressing the Bluetooth® shoulder button on the SCU. Once connected, the two-way radio's regular push-to-talk (PTT) button should be used to transmit over that channel.

Transmissions are received and played back through the microphones and vary depending on which communications are active.

- In non-Bluetooth® operations, incoming close-connect transmissions are played back in both ears.
- In Bluetooth® operation, incoming calls are played back in both ears.
- If a close-connect transmission comes in during an active Bluetooth® phone call, the playback will be split; the right earpiece will playback Bluetooth® communications, while the left earpiece will playback incoming close-connect transmissions.

The right ear microphone is always used for Bluetooth® communication regardless of what the PIC-100 headset is Bluetooth® connected with (smartphone, tablet, or two-way radio) while the left-ear microphone is always used to pick up the user's voice for the close-connect radio.

NOTE: The operation is dependent on the phone(s), tablet, or radio's interoperability with the PIC-100 headset.

11.8. PUSH-TO-TALK (PTT)/VOX

There are two options available for how to communicate with the close-connect radio:

- PTT mode (default)
- VOX mode

Double press on the PTT button (2) to toggle between PTT and VOX mode (refer to the figure below).

An audio message will announce current mode.

PTT MODE

Press and hold the Push-To-Talk (PTT) button to transmit two-way (full duplex) close-connect radio.

When you transmit using PTT, the close-connect light (1) will pulse white.

When you receive incoming communication, the close-connect light will glow full white.

If there are no other PIC-100 headsets in range, you will hear a two-tone beep. If no network is connected, close-connect light will not be illuminated.



More information of the close-connect, refer to chapter 11.8.1. HOW CLOSE-CONNECT TECHNOLOGY WORKS.

VOX MODE

Hands-free communication. Speak to transmit on close-connect radio.

VOX enables automatic transmission when the sound level at the microphone is above the VOX level. This allows radio transmission without pressing the button.

When VOX is enabled, the PTT button will be locked unless you double press on the PTT button to enable.

When you transmit using VOX, the close-connect light (1) (see figure above) will pulse orange.

When you receive incoming communication, the close-connect light will glow full orange.

If there are no other PIC-100 headsets in range, you will hear a two-tone beep. If not connected to network, close-connect light will not be illuminated.

11.8.1. HOW CLOSE-CONNECT TECHNOLOGY WORKS

The PIC-100 headset features a built-in close-connect radio used for quick and easy non-critical short-range communication.

- Transmission range: 20 m/22 yd from the talker (T).
- Up to 50 listeners (L) within the transmission range.
- 4 full-duplex simultaneously talkers (T).

Up to 4 users within ≈ 20 m/22 yd can transmit simultaneously using 1 of 4 open slots/channels. Once all 4 channels are active, no one else in the group can transmit until a channel becomes available. If a fifth person tries to transmit, a beeping sound will indicate that the message was not transmitted. This ≈ 20 m/22 yd range is in an open field (line of sight) and may be reduced by the presence of physical structures and if workers are communicating back to back versus face-to-face. A beeping sound is also played if no other users are within range.

The figure below is for illustration purposes only.

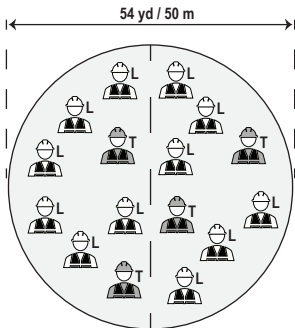

The close-connect technology can be operated using Voice Activated Transmission (VOX) or using the PTT activated transmission.

12. MENU FUNCTIONS

To enter Menu mode, quick press the Power/Menu button (1) and cycle through the menu items.

The current status of each setting is announced as you cycle through the menu options.

Use the (+) and (-) buttons to adjust each items' respective setting. Each short press of Power/Menu button toggles to the next menu item.

If menu items are disabled in the Advanced Settings, you will not hear the audio message for that menu item when you toggle through the menu.

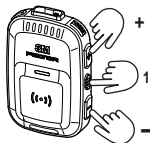

MENU STRUCTURE

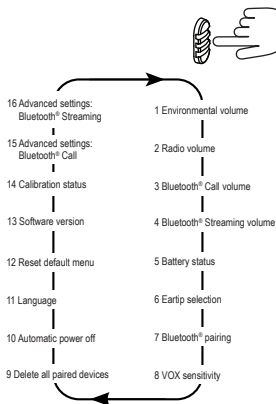

12.1. ENVIRONMENTAL VOLUME

Determines default setting of the environmental volume level. The setting offers 6 preset volume levels and silent mode (OFF). The left indicator is red when environmental volume is Off. All other levels are indicated in green.

Use (+) and (-) buttons to alter volume setting.

An audio message confirms a change.

The indicators reflect the change as shown in the figure below.

After 2 seconds delay, the indicators return to user selected channel light.

Audio message	Indicators
"Environmental volume 4"	

12.2. RADIO VOLUME (CLOSE-CONNECT)

Determines default setting of the radio (close-connect) volume level.

The setting offers 6 preset volume levels and silent mode (OFF). The left indicator is red when radio volume is Off. All other levels are indicated in orange.

Use (+) and (-) buttons to alter volume setting.

An audio message confirms a change.

The indicators reflect the change as shown in the figure below.

After 2 seconds delay, the indicators return to user selected channel light.

Audio message	Indicators
"Radio volume 4"	

12.3. BLUETOOTH® CALL VOLUME

Determines default setting of the Bluetooth® call volume level. The setting offers 6 preset volume levels and silent mode (OFF). The left indicator is red when Bluetooth® call volume is Off. All other levels are indicated in blue.

Use (+) and (-) buttons to alter volume setting.

An audio message confirms a change.

The indicators reflect the change as showed in the table below.

After 2 seconds delay, the indicators return to user selected channel light.

Audio message	Indicators
"Bluetooth® call volume 4"	

12.4. BLUETOOTH® STREAMING VOLUME

Determines default setting of the Bluetooth® streaming volume level. The setting offers 6 preset volume levels and silent mode (OFF). The left indicator is red when Bluetooth® streaming volume is Off. All other levels are indicated in purple.

Use (+) and (-) buttons to alter volume setting.

An audio message confirms a change.

The indicators reflect the change as showed in the table below.

After 2 seconds delay, the indicators return to user selected channel light.

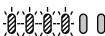
Audio message	Indicators
"Bluetooth® Streaming volume 4"	

12.5. BATTERY STATUS

An audio message will announce current battery status based on the percentage remaining.

A warning message is announced for low battery during normal device operation. The message will be repeated in intervals.

Audio message	Indicators
"Battery status xx%"	None

12.6. EARTIP SELECTION

This setting shall correspond to the current installed eartip: CCC, UltraFit™ (Small, Medium and Large), Skull Screw™.

Use (+) button to alter setting.

Audio messages report ea

This setting is used by the SCU when the real-time fit test is performed.

Audio message	Indicators
Eartip model	None

12.7. BLUETOOTH® PAIRING

Use (+) and (-) buttons to turn pairing on or off.

Pairing is started when pairing mode is on and SCU serial number is selected from within the phone's or Bluetooth® radio's menu settings.

Thereupon the Bluetooth® device is paired and also connected. If Bluetooth® device is disconnected, then it remains paired.

Audio message	Indicators
"Bluetooth® pairing on" when pairing mode is activated	 <p>When in pairing mode, status LED (1) quickly blinks blue. Once paired, status LED will double-blink blue, then stay on for 4 seconds. After 4 seconds, status LED turns off (or resumes activity prior to pairing).</p>
"Bluetooth® pairing off" when pairing mode is deactivated	
"Device connected" when Bluetooth® device is connected	
"Device disconnected" when Bluetooth® device is disconnected	

12.8. VOX SENSITIVITY

Adjust sensitivity levels of voice activated transmission. You can choose between low, medium or high.

When the level is high it is easier to transmit.

Use (+) button to alter volume setting.

An audio message confirms a change.

Audio message	Indicators
"VOX sensitivity: low"	None
"VOX sensitivity: medium"	
"VOX sensitivity: high"	

12.9. DELETE ALL PAIRED DEVICES

This function is used when you want to delete all paired devices.

An audio message is announced when entering the menu.

Use the (+) button to accept deletion. Device reboots automatically.

Use the (-) button to decline.

Audio message	Indicators
"Delete all paired devices"	None
"All paired devices deleted"	

12.10. AUTOMATIC POWER OFF

The SCU can be set for automatic power off if no activity is detected within the set time.

Available options: Off, 2 hours and 8 hours.

Use (+) button to alter setting.

Audio messages report each option when cycling through the options.

Audio message	Indicators
Audio messages: "Off" "2 hours" "8 hours"	Animation from outside LEDs to inside for the duration of the power-down.
An audio message is given when the SCU performs automatic power off: "Automatic power off", followed by a series of short tones for 10 seconds, then the unit is switched off.	

12.11. LANGUAGE

Use this menu to alter the language for audio messages.

Use (+) button to navigate through available languages.

As you cycle through the languages, they will automatically be applied to all audio prompts.

Audio message	Indicators
Language/Langue/dioma/Sprache	None
English Français Español Deutsch	None

12.12. RESET DEFAULT MENU

You will be given the option to reset default menu (audio prompt). Use the (+) button to accept deletion. Device reboots automatically. Use the (-) button to decline.

Audio message	Indicators
"Reset default menu"	None

12.13. SOFTWARE VERSION

An audio prompt will provide the software version.

12.14. CALIBRATION STATUS

An audio prompt will provide the number of months until the 90-day mark, then provide the number of days until a new calibrated headset is needed. After 2 years, the audio prompt will then say "headset calibration expired." Additionally, an audio reminder is provided when a fit test is performed beginning at 90 days prior to expiration and repeated at intervals thereafter until a new calibrated headset is connected to the SCU and your system is powered on for the first time.

If the headset has expired, the audio prompt for a successful fit test will say, "PAR value + eartip type + calibration expired." You can also check the status of the calibrated headset via the PIC-100 Connected App.

NOTE: You may be required to replace your calibrated headset sooner than 2 years if the headset is damaged and/or the earpieces are unable to pass the daily check.

12.15. ADVANCED SETTINGS: BLUETOOTH® CALL

Access to the advanced settings options are enabled by your program administrator. To access the advanced settings menu, enter the menu by quick pressing the Power/Menu button. Press the Power/Menu button until you reach the "Battery Status" menu option. Press the (-) button 10 times. An audio prompt will state, "Advanced Setting Active." (The advanced settings menu will return to being disabled when the SCU is powered off.) Pressing the menu button will allow you access to the Advanced Settings - Bluetooth® Call ON/OFF. The default setting for Bluetooth® Call is ON.

12.16. ADVANCED SETTINGS: BLUETOOTH® STREAMING

Once you have activated the Advanced Settings as described above in 12.15., Pressing the menu button will allow you access to the Advanced Settings - Bluetooth® Streaming ON/OFF. The default setting for Bluetooth® Streaming is OFF.

13. FLX2 OPERATION EXPLAINED

The 3M™ PELTOR™ FLX2 Cable to PIC-100 headset, FLX2-214, fits 3M™ PELTOR™ CH-3 FLX2 Headset with built-in PTT (-111 models). This is available as an accessory (see Section 17.) and allows for the connection between the PIC-100 SCU and a 3M PELTOR headset for an over-the-ear alternative to the in-ear headset.



To connect, firmly insert the connector (1) into the receptacle located on the bottom of the left earcup until you feel/hear a click.

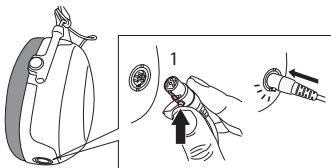

Align and connect the connector (2) to the socket in the SCU. Observe that the connector must be inserted so the keys fit, (a) and (b).

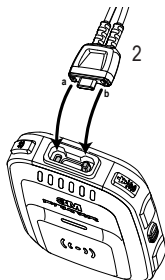

To power on, press and hold the Power/Menu button for a minimum of 5 seconds. Headset must be connected to the SCU to power on.



3M™ PELTOR™ CH-3 Headset compatible models:

Article number	Description	3M ID
MT74H52A-111	3M™ PELTOR™ CH-3 FLX2 Headset with Built-In PTT, Headband, Yellow	7100203638
MT74H52B-111	3M™ PELTOR™ CH-3 FLX2 Headset with Built-In PTT, Neckband, Yellow	7100205729
MT74H52P3E-111	3M™ PELTOR™ CH-3 FLX2 Headset with Built-In PTT, Carrier attached, Yellow	7100203150

The 3M™ PELTOR™ FLX2 Cable & the compatible CH-3 headsets function like the PIC-100's standard headset except for a few operational differences.

- Environmental listening operation is disabled. "Environmental volume" is removed from the menu (Section 1. "Environmental volume" no longer applies).
- Daily check and real-time fit testing operation are disabled. "Eartip selection" and "Calibration status" is removed from the menu (Section 6. "Eartip selection" and Section 14. "Calibration status" no longer apply).
- When the PIC-100 headset is paired to a two-way radio, push the PTT on the radio to transmit.

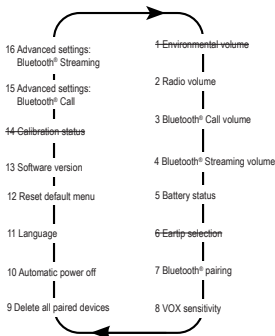

14. TROUBLESHOOTING

Problem	Possible Issue/Solution
The SCU will not power on.	Make sure the battery in the SCU is fully charged and connected to a headset.
	Poor battery. Replace the battery.
I can't get the fit test to give me a PAR.	Conduct a daily check to check the integrity of the headset microphones and wires. If the earpieces pass, follow the fit-test procedures and try again.
Headset unable to pass the daily check.	Ensure the conditions are suitable for conducting the daily check. If earpiece(s) still do not pass the daily check, do not conduct real-time fit tests or rely on the fit-test results. Contact your supervisor. You may need to replace with a new calibrated headset.
I hear a beeping sound when attempting to transmit using radio communication PTT or VOX.	All 4 channels are occupied/busy or no other PIC-100 headset users are in range. Repeat transmission until a channel becomes available.

Problem	Possible Issue/Solution
Pairing failed.	<p>Make sure the Bluetooth® device to pair is set to pairing mode and ready for pairing.</p> <p>The Bluetooth® device to pair is out of range.</p>
Transmission does not start when pressing the PTT button.	The SCU is set for VOX operation. Double press the PTT button and listen for an audio message that confirms the PTT mode is selected.
Transmission does not start when I start to talk.	The SCU is set for PTT operation. Double press the PTT button and listen for an audio message that confirms the VOX mode is selected.
I do not hear any sound from the earplugs.	<p>The headset is not connected to the SCU. Connect the headset connector to the socket in the SCU.</p> <p>There is a headset cable problem. Replace the headset.</p>
I cannot hear any sound out of one earplug	<p>Eartip may be folded. Check to see if eartip is folded onto itself; reinsert.</p> <p>Eartip opening may be blocked. Check the eartip for blockage, replace if blocked. Refit and fit test.</p>
My outbound radio transmission sounds distorted. My close-connect team members complain that they can't understand me when I talk.	<p>Your hearing protectors may not be properly fitted which can interfere with sound clarity.</p> <p>Refit your hearing protectors and conduct a real-time fit test to check your fit.</p>
Battery pack LED light does not illuminate when charging.	The battery is out of the recommended charging temperature range. Bring the battery pack to room temperature and try charging again.
I get an audio prompt that my calibration status is "unknown".	The SCU likely requires service to replace a faulty coin cell. Contact 3M Technical Assistance for support.

15. STORAGE AND DISPOSAL

15.1. STORAGE

- Always store the PIC-100 headset in a clean area.
- Clean the product before storage.
- Examine the product for wear or damage.
- Keep the product in a clean and dry area (<90% humidity) within a temperature range of -20°C/-4°F to 40°C/104°F.
- Do not put the product in sunlight during storage.

15.2. DISPOSAL

- Obey national regulations.
- To properly dispose of the battery, follow local solid waste disposal regulations.
- Use the local recycling system for electronic equipment.

15.2.1. BATTERY DISPOSAL

Many rechargeable batteries are required to be recycled by local, state/province, and national laws. To properly recycle/dispose of the battery or battery pack, always follow local solid waste disposal regulations.

Additionally in the United States and Canada, 3M Company is partnering with Call2Recycle (RBRC) to provide recycling service to you to help ensure that the rechargeable batteries within our products are recycled properly. To assist you in using this service call the Call2Recycle battery recycling information help line at 1-800-8-BATTERY (1-800-822-8837) or consult Call2Recycle's battery recycling guidance online at www.call2recycle.org.



16. MAINTENANCE

Examine the earplugs regularly for damage. A damaged earpiece or dirty and/or damaged eartips must be replaced. Refer to chapter 17. ACCESSORIES.

16.1. TO CLEAN THE PRODUCT

16.1.1. PIC-100 HEADSET EARPIECES

- Clean the earpieces with a lightly damp cloth.

NOTE: Do not immerse in water.

16.1.2. 3M™ ULTRAFIT™ EARTIPS

- Clean eartips with warm water and soap as needed.
- Look for tears or cracks under any of the flanges. Replace as needed.

16.1.3. 3M™ SKULL SCREW™ COMMUNICATION EARTIPS AND 3M™ PELTOR™ CCC-GRM-25 EARTIPS

- Clean by wiping with a clean, dry cloth.
- Replace the eartip if the eartip is damaged.
- Replace the eartip if it is detached from the stem.
- Replace the eartip if the eartip is not soft and pliable.

16.1.4. SCU

- Clean the SCU with a lightly damp cloth.
NOTE: Do not immerse in water.
- To maintain water resistance capability, the gasket surrounding the battery contacts must be kept free of dirt and other materials that would prevent proper mating of the battery.

16.2. CALIBRATION

The first time that the PIC-100 headset is plugged into the SCU and powered on, the two-year calibration cycle begins. You will be reminded to replace your headset with a new calibrated headset beginning 90 days prior to its expiration and periodically thereafter. To hear when a new calibrated headset is due, refer to 12.13. SOFTWARE VERSION.

17. ACCESSORIES

Product number	Name
PIC-100HD	3M™ PELTOR™ Replacement Headset
PIC-100BA	3M™ PELTOR™ Replacement Battery
PIC-100CL	3M™ PELTOR™ Replacement Clip
PIC-100CS	3M™ PELTOR™ Charging Station, PIC-100CS
370-TEPL-25	3M™ UltraFit™ Communication Tips Replacement, Large, 25 pairs
370-TEPM-25	3M™ UltraFit™ Communication Tips Replacement, Medium, 25 pairs
370-TEPS-25	3M™ UltraFit™ Communication Tips Replacement, Small, 25 pairs
CCC-GRM-25	3M™ PELTOR™ CCC-GRM-25 Communication Eartips, 25 pairs
370-1019-10	3M™ Skull Screw™ Communication Eartips, 10 pairs
MSC-YLM-25	3M™ Skull Screw™, Metal Detectable Communication Eartips, 25 pairs
FLX2-214 FLX2 CABLE PIC-100	3M™ PELTOR™ FLX2 cable to PIC-100, FLX2-214, fits -111 headsets, 120/case

18. WARRANTY AND LIMITATION OF LIABILITY

18.1. WARRANTY

In the event any 3M Personal Safety Division product is found to be defective in material, workmanship, or not in conformity with any express warranty for a specific purpose, 3M's only obligation and your exclusive remedy shall be at 3M's option, to repair, replace or refund the purchase price of such parts or products upon timely notification of the issue by you and substantiation that the product has been stored, maintained and used in accordance with 3M's written instructions.

EXCEPT WHERE PROHIBITED BY LAW, THIS WARRANTY IS EXCLUSIVE AND IS IN LIEU OF ANY EXPRESS OR IMPLIED WARRANTY OR CONDITION OF MERCHANTABILITY, FITNESS OR A PARTICULAR PURPOSE OR OTHER WARRANTY OR CONDITION OF QUALITY, OR THOSE ARISING FROM A COURSE OF DEALING, CUSTOM OR USAGE OF TRADE, EXCEPT OF TITLE AND AGAINST PATENT INFRINGEMENT.

3M has no obligation under this warranty with respect to any product that has failed due to inadequate or improper storage, handling, or maintenance; failure to follow product instructions; or alteration or damage to the product caused by accident, neglect, or misuse.

18.2. LIMITATION OF LIABILITY

EXCEPT WHERE PROHIBITED BY LAW, IN NO EVENT SHALL 3M BE LIABLE FOR ANY DIRECT, INDIRECT, SPECIAL, INCIDENTAL OR CONSEQUENTIAL LOSS OR DAMAGES (INCLUDING LOST PROFITS) ARISING FROM THIS PRODUCT, REGARDLESS OF THE LEGAL THEORY ASSERTED. THE REMEDIES SET FORTH HEREIN ARE EXCLUSIVE.

18.3. NO MODIFICATION

Modifications to this device shall not be made without the written consent of 3M Company. Unauthorized modifications may void the warranty and the user's authority to operate the device.



3M Personal Safety Division
3M Center
St. Paul, MN 55144-1000

FOR MORE INFORMATION

In United States, contact:

www.3M.com/PELTOR
Technical Assistance:
1-800-665-2942
PELTOR.comms@mmm.com

In Canada, contact:

1-855-484-3093
PELTOR.comms.canada@mmm.com

For other 3M products:
1-800-3M-HELPS or 1-651-737-6501

3M, PELTOR, Skull Screw, E-A-R and UltraFit are trademarks of 3M Company, used under license in Canada.

© 2022, 3M. All rights reserved.

The Bluetooth® word mark and logos are registered trademarks owned by Bluetooth SIG, Inc. and any use of such marks by 3M Company is under license.

USB Type-C® and USB-C® are registered trademarks of USB Implementers Forum.

3M PSD products are occupational use only. Always read and follow User Instructions.

Patent: www.3M.com/patent
Please recycle.

3M Personal Safety Division
3M Canada Company
P.O. Box 5757, London, Ontario
N6A 4T1

Division de la protection individuelle - 3M Company Canada

3M Canada, C.P. 5757
London (Ontario) N6A 4T1

FOR MORE INFORMATION/POUR OBTENIR DE PLUS AMPLES RENSEIGNEMENTS

In Canada, contact/Au Canada, communiquer avec :

Internet : www.3M.ca/safety
Technical Assistance/Assistance technique : 1 800 267-4414
Centre d'aide à la clientèle/Customer Care Center : 1 800 364-3577

3M, PELTOR, Skull Screw, E-A-R et UltraFit sont des marques de commerce de la compagnie 3M, utilisées sous licence au Canada.
© 2022, 3M. Tous droits réservés.

La marque verbale et les logos Bluetooth® sont des marques déposées de Bluetooth SIG, Inc. et toute utilisation de ces marques par 3M est sous licence.

USB Type-C® et USB-C® sont des marques déposées d'USB Implementers Forum.

Les produits de la DPI de 3M sont destinés à une utilisation professionnelle seulement.
www.3M.com/patent
Veuillez recycler.

PARA OBTENER MÁS INFORMACIÓN en los Estados Unidos:

Internet: www.3M.com/PELTOR
Información técnica: 1-800-665-2942

3M, PELTOR, Skull Screw, E-A-R y UltraFit son marcas registradas de 3M Company, usadas bajo licencia en Canadá.

© 2022, 3M. Todos los derechos reservados.

La marca y los logotipos Bluetooth® son marcas registradas, propiedad de Bluetooth SIG, Inc., y todo uso de tales marcas por 3M se hace con licencia.

USB Type-C® y USB-C® son marcas registradas de USB Implementers Forum.

Los productos de la División de Protección Personal (PSD, por su sigla en inglés) de 3M son solo para uso profesional.

Patentes: www.3M.com/patent
Por favor recicla.