

REVISION RECORD

DATE	REV	ECN	DESCRIPTION	DR	APP
06/08/18	A	55873	RELEASED FOR PRODUCTION	ERW	MAB

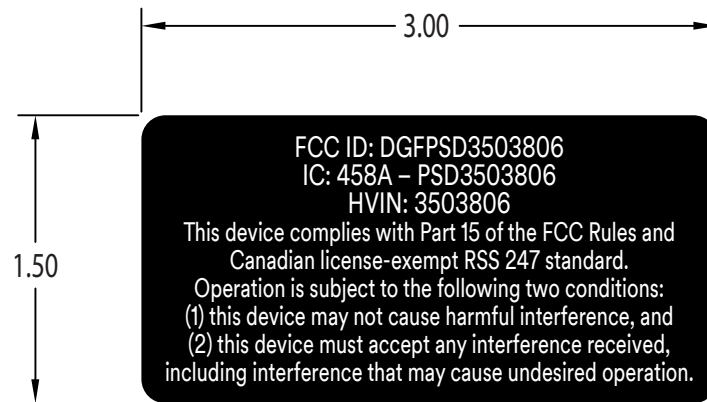

NOTES:

- MATERIAL: .002 WHITE POLYESTER (FLEXCON DPM LSE PM 200) WITH .005 VELVET POLYCARBONATE OVERLAMINATE. MATERIAL SHALL BE PART OF A UL RECOGNIZED LABELING SYSTEM SUITABLE FOR OUTDOOR USE ON A STEEL SUBSTRATE.
- WHITE COPY ON BLACK BACKGROUND.
- USE THE CURRENT REVISION OF FILE 9514374.ai FOR LABEL GEOMETRY AND ARTWORK. ALL LABEL GEOMETRY TOLERANCE SHALL BE $\pm .01$.
- MANUFACTURER SHALL PROVIDE DOCUMENTATION DUE UPON ARRIVAL OF EACH SHIPMENT CERTIFYING THE FOLLOWING:

A) THE PARTS ARE EU REACH AND EU RoHS COMPLIANT.

<small>UNLESS OTHERWISE SPECIFIED DIMENSIONS ARE IN INCHES</small> TOLERANCES ON: 2 PL DECIMALS \pm 3 PL DECIMALS \pm ANGLES \pm ° FRACTIONS \pm	© 3M COPYRIGHT This document is the copyrighted property of the 3M Company and may not be reproduced without 3M written permission or used for other than 3M authorized purposes.			
	SCALE 1:1	ILLUSTRATOR	Red Wing, MN, USA	
SIGNATURES		DATE		TITLE LABEL,dSRL FCC
DRAWN	ERW	06/08/18		
CHECKED	MAB	06/08/18		
APPROVED	MAB	06/08/18		
SHEET 1 OF 1		DO NOT SCALE DRAWING	DRAWING NUMBER 9514374	REVISION A



51	1	9514374	LABEL, FCC COMPLIANCE, DIGITAL SRL
----	---	---------	------------------------------------

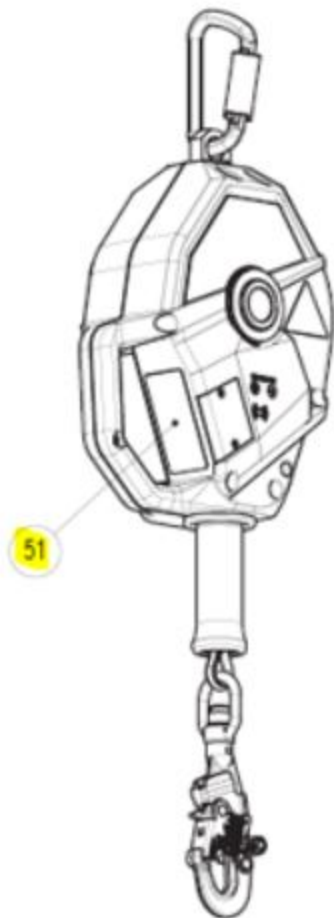

SCALE 0.250

