

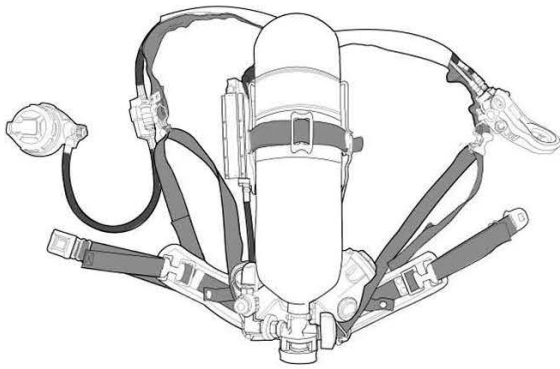

# 3M™ SCOTT™ AIR-PAK™ XD OPTIONS AND ACCESSORIES



3M™ Scott™ Air-Pak™ XD SCBA



3M™ Scott™ Pak-Tracker Handheld Receiver



3M™ Scott™ SCBA Advanced Electronics Console



3M™ Scott™ Advanced Electronics Gateway

**READ ALL INSTRUCTIONS BEFORE USE**

**THESE USER INSTRUCTIONS ARE TO BE REMOVED BY THE END USER ONLY**

All information, illustrations, and specifications in this User Instruction are based on the latest product information available at the time of publication. 3M Scott reserves the right to make changes at any time without notice.

The contents of this manual may not be used, reproduced, or disclosed to any third party in whole or in part without obtaining express written permission and authorization from 3M Scott.

### ***Cautionary Notice***

While the manufacturer has attempted to detail in this manual all areas of possible danger to personnel in connection with the use and servicing of this equipment, personnel should use caution when installing, inspecting, operating, and servicing this equipment, especially when handling pressurized air cylinders. When maintaining or operating all electronic equipment, care should be taken to avoid electrical shock in all circuits where substantial currents or voltages may be present through design or component failure. Caution should be observed in lifting and hoisting heavy equipment.

The manufacturer is specifically not liable for any damage or injury arising out of a user's failure to follow the instructions contained in this manual or failure to exercise due care and caution in the installation, operation, inspection, and service of this equipment.

### ***Import and Export***

The international transport of this equipment and any related documentation is regulated under United States export laws and regulations and may be regulated by the import or export laws and regulations of other countries.

If you have any questions or concerns regarding these regulations, contact 3M at +1-800-247-7257 (+1-704-291-8300 outside the continental United States).

### ***Questions or Concerns***

If you have any questions or concerns regarding use of this equipment, contact your authorized distributor, or contact the company at 1-800-247-7257 (or +1-704-291-8300 outside the continental United States) or visit our web site at [3M.com/ScottFire](http://3M.com/ScottFire). Report any malfunctions of this SCBA to your 3M Scott Authorized Service Centre. For all National Fire Protection (NFPA)- compliant versions of this SCBA, the Safety Equipment Institute (SEI) can be notified (<https://www.seinet.org/>).

	<b>Safety Information</b> .....	<b>5</b>
	3M™ Scott™ Personal Alert Safety System (PASS) and Advanced Electronics SCBA Telemetry System .....	5
<b>Chapter 1</b>	<b>3M™ Scott™ Personal Alert Safety System (PASS)</b> .....	<b>9</b>
	System Components .....	9
	PASS Control Console .....	9
	Sensor Module Assembly .....	9
	Operation .....	9
	Activation .....	9
	Pre-Alarm .....	9
	Full Alarm .....	10
	Manual Alarm .....	10
	Deactivation .....	10
	Low Battery .....	11
	Battery Test .....	11
	Data Logging Feature .....	11
<b>Chapter 2</b>	<b>3M™ Scott™ Pak-Tracker Locator System</b> .....	<b>13</b>
	Introduction .....	13
	Operation .....	13
	Use as part of an accountability system .....	14
	Detecting and avoiding radio frequency interference .....	14
<b>Chapter 3</b>	<b>3M™ Scott™ Advanced Electronics</b> .....	<b>17</b>
	Introduction .....	17
	Advanced Electronics Overview .....	17
	Additional system components .....	17
	Advanced Electronics Control Console .....	17
	Advanced Electronics Gateway .....	17
	Programmable ID Tags and Programming Equipment .....	17
	3M™ Scott™ Monitor Telemetry Software .....	18
	Additional Features Added to the Console .....	18
	System Operation .....	18
	Console Buttons .....	18
	Console Operations .....	20
	Base Station Definition and Operation .....	20
	Monitor Telemetry Software Solution .....	21
<b>Chapter 4</b>	<b>Cleaning and maintenance</b> .....	<b>23</b>
	Regular Operational Inspection .....	23
	Operation of Sensor Module Lights .....	25
	Cleaning, Maintenance, and Storage .....	25
	Marking and Painting .....	26
	Replacement Parts and Service .....	26
	Retirement Criteria and Consideration .....	26
	Battery Replacement .....	26
	Safety Listings .....	28
	Compliance .....	28
	Radio Frequency Interference (RFI) .....	28
	Intrinsically Safe Listing .....	28
	Handheld Receiver Non-Incendive Listing .....	29
	Personal or Tablet Computer .....	29
	Export and Import .....	29
	End User License Agreement .....	29
	Quick Reference Guide .....	30



# SAFETY INFORMATION

Read all of the safety information before beginning any of the procedures in this User Instruction.

---

## **3M™ Scott™ Personal Alert Safety System (PASS) and Advanced Electronics SCBA Telemetry System**

The following safety directives, warnings, and cautions apply to 3M™ Scott™ PASS and Advanced Electronics SCBA Telemetry System:

- Improper use of this equipment may result in serious injury or death. Improper use includes, but is not limited to, use without adequate training, disregard of the warnings and instructions contained herein, and failure to inspect and maintain this equipment. Read and understand all instructions before attempting to operate or service this equipment.
- The information in this user instruction is meant to supplement — not replace — the instructions, training, supervision, maintenance, and other elements of your organized respiratory protection program.
- No Personal Alert Safety System, SCBA, or combination of Personal Alert Safety System and SCBA by themselves can provide complete protection in fire situations. However, using an alarm and an SCBA in accordance with the requirements of an organized respiratory protection program is one of the many safety precautions which should be taken to avoid personal injury or death.

**WARNING**

To reduce the risks associated with fire, explosion, battery chemosis, exposure to contaminants, and/or oxygen-deficient atmospheres which, if not avoided, could result in serious injury or death:

- Follow the regular operational inspection procedures exactly.
- Do not use the equipment if it does not operate as described in these instructions. If there are any operational malfunctions, remove the SCBA from service and tag for repair by authorized personnel.
- Do not attempt to perform maintenance or repairs beyond the scope of these instructions.
- A 3M Scott authorized service provider must service the system.
- Use only 3M Scott approved replacement parts for maintenance and repair of this SCBA.
- Stay alert when operating this equipment.
- Do not operate this equipment if/when fatigued, while under the influence of drugs, alcohol, or medication that may affect vision, dexterity, or judgment, and the user is not in good physical and/or mental health.
- The PASS is an electronic, battery-operated device that may malfunction due to radio frequency interference (RFI), damage to the device or its battery, or device component defect. The user of the SCBA equipped with the PASS must be trained in the proper operation of the distress alarm and be able to recognize and take corrective action in the event the device malfunctions.
- Training is required before use of the Pak-Tracker Locator System in a hazardous situation. Training use includes extensive practice with the system in a variety of environments.
- The PASS may malfunction due to radio frequency interference (RFI). See "Radio Frequency Interference (RFI)" and "Detecting and Avoiding Radio Frequency Interference" for information and instructions on how to identify RFI sources and associated symptoms due to RFI.
- Replace the batteries in the PASS when the low battery alarm sounds. See the "Low Battery" on page 11 of these instructions.
- The user must leave the contaminated area at once when the end-of-service time indicator actuates. This occurs at approximately 35% of the full pressure of the cylinder.
- User of the SCBA must be properly trained in the operation of the PASS device and the Advanced Electronics control console.
- If equipped with the telemetry console, the EVAC symbol on the console flashes, the SCBA user must leave the hazardous area immediately.
- Regularly inspect the electronic components, as described in the instructions, for loose or worn electrical conductors or incorrectly installed battery.
- Use only batteries from the list provided in these instructions for this equipment.
- Do not mix old and new batteries.
- Do not mix batteries from different manufacturers.
- Replace batteries in an area free of flammable gases, vapors and dust.
- Make sure the battery compartment on the PASS is properly closed but do not over tighten nor under tighten. Refer to "Battery Replacement" of these instructions.
- Any contaminants must be identified and effectively removed.
- Contaminated components must be removed and disposed of in accordance with applicable regulations.
- Use a communication method other than the base station and accountability software with firefighter resources wearing SCBA not equipped with the Advanced Electronics system, the base station will not be able to transmit or receive communications from these resources.



**WARNING**

To reduce the risks associated with fire, explosion, battery chemicals, exposure to contaminants, and/or oxygen-deficient atmospheres which, if not avoided, could result in serious injury or death:

- Do not use an RFID tag reader that has an output power greater than 0 watts while in a flammable atmosphere.
  - Do not take the base station into a fire or into a potentially flammable or explosive atmosphere.
  - If multiple 3M™ Scott™ Monitor base stations are in use at a scene, an SCBA from one fire company might connect to a different company's base station.
  - Power options on the base station computer should be configured such that the computer will not turn off or reduce power to its display, USB ports, and other peripheral devices. Additionally the power options should be set to disable automatically if the power options are not properly setup which will stop all communication between the Advanced Electronics enabled SCBA and the Connect Monitor software.
  - The PC or Tablet used as part of the "Base Station" must maintain a minimum battery charge to maintain operation for one (1) hour under full alarm conditions.
  - All audible alarms sound from the speakers on the base station computer.
  - Do not turn off or mute the speakers on the base station computer during an active event.
-

**SAFETY INFORMATION**



# 3M™ SCOTT™ PERSONAL ALERT SAFETY SYSTEM (PASS)

---

## System Components

### PASS Control Console

Shoulder console equipped with the following features:

- A mechanical air supply gauge
- A Red PASS device manual activation button
- Yellow Reset button
- System indicator LEDs located around the Red PASS button

### Sensor Module Assembly

Electronics control module for battery power, audio (alarm tones), the Pak-Tracker radio transmitter, data logging, wireless communications, and the motion sensor are installed on the SCBA backframe. The PASS monitors the motion of SCBA backframe and initiates visible and audible warnings when the user is motionless for a short period of time or when manually activated by the user.

---

## Operation

The console will remain silent, and the PASS Signal Lights will not be illuminated when the PASS is turned off and while operational tests that utilize the lights and audible tones are not initiated.

### Activation

The PASS system is automatically activated when the SCBA is pressurized by opening the cylinder valve of the SCBA. To indicate activation, the Sensor Module will sound three (3) quick audible chirps and the green PASS Signal Light located on the Control Console will flash approximately once every three (3) seconds. The PASS is now in sensing mode.

Once activated, the PASS constantly monitors motion of the SCBA backframe. The Sensor Module is located on the SCBA backframe beneath the air cylinder and contains the motion sensor and the audible alarm. Once activated, the PASS constantly monitors motion of the SCBA backframe. If the Sensor Module does not sense motion of the SCBA for twenty (20) seconds, the PASS will signal a pre-alarm condition. If there is still no motion of the SCBA for the next twelve (12) seconds, the full alarm will sound.

The PASS will remain activated until turned OFF according to these instructions.

### Pre-Alarm

If the SCBA remains motionless for more than twenty (20) seconds, the PASS will automatically sound a pre-alarm.

When the pre-alarm occurs, the green flashing PASS Signal light on the Control Console is replaced by alternating

## 3M™ SCOTT™ PERSONAL ALERT SAFETY SYSTEM (PASS)

bright red PASS Signal lights which flash approximately once per second and are accompanied by an ascending/descending audible tone that increases in volume during the pre-alarm cycle.

If the SCBA user is not incapacitated or not in need of assistance, move the SCBA to reset the pre-alarm. When reset, the flashing red PASS lights are replaced by the flashing green PASS Signal light and the ascending/descending tone stops.

Remember that the motion sensor is in the Sensor Module on the SCBA backframe beneath the air cylinder. Actual movement of the SCBA backframe is required to reset the pre-alarm. Shaking the Control Console will not reset the PASS device.

To manually reset the pre-alarm, press the yellow Reset button on the side of the Control Console until three (3) quick audible chirps are heard and the red flashing light on the Control Console is replaced by the green flashing light.

### Full Alarm

If the SCBA remains motionless through the twelve (12) second pre-alarm cycle, the PASS will go into full alarm. This may indicate that the user is incapacitated or in need of assistance and cannot move.

Full alarm is indicated by a loud alarm tone from the Sensor Module accompanied by simultaneous flashing red PASS signal lights on the Control Console. After an additional (10) second delay, the unit will send a notification of PASS activation to the Pak-Tracker Locator transmitter and Advanced Electronics Base Station, if equipped with the Advanced Electronics Option. The PASS module will then begin transmitting the unique ID number that can be received by the Pak-Tracker Handheld Unit.

To reset the full alarm condition, press the yellow Reset button twice. After the full alarm has been silenced, the PASS device will remain activated in sensing mode with the green PASS Signal light flashing once per second. If the SCBA is pressurized, there must be movement of the SCBA at least every twenty (20) seconds or the PASS device will again go into pre-alarm followed by full alarm as described above.

### Manual Alarm

If the SCBA user requires immediate assistance, pressing the red manual alarm button located on the front of the Control Console will immediately sound the full alarm. The manual alarm may be activated at any time, even when the SCBA is not pressurized.

The manual alarm is indicated by a loud alarm tone from the Sensor Module accompanied by simultaneous flashing red PASS signal lights on the Control Console. The unit will immediately send a notification of PASS alarm activation to the Pak-Tracker transmitter and the Advanced Electronics Base Station, if equipped with the Advanced Electronic Option. The PASS module will then begin transmitting the unique ID number that can be received by the Pak-Tracker Handheld Unit.

To reset the manual alarm, press the yellow Reset button twice. After the alarm has been silenced, the PASS will remain activated in sensing mode.

Remember, the loud audible alarm and flashing red PASS Signal lights can be turned on at any time by pressing the manual alarm button on the Control Console.

### Deactivation

**When use of the SCBA, with the PASS device, is no longer required:**

- Close the cylinder valve on the SCBA
- Vent the residual air from the SCBA system by opening the regulator purge valve
- After all the air flow stops, close the purge valve
- Press the reset button twice to turn off the PASS alarm



- If there is no pressure in the system when the yellow Reset button is pressed twice, the unit will sound a quick two-tone chirp to indicate that the alarm has been turned off.
- The PASS cannot be turned off while air pressure remains in the SCBA system.
- If the air pressure was not completely bled from the system, and the yellow Reset button is pressed twice, the green PASS Signal Light will continue to flash green while the SCBA emits an audible chirp approximately once every two seconds for fifteen (15) seconds.
- If the remaining air pressure is released during the fifteen second period, the PASS will turn off. If the remaining air pressure is not released, the PASS will resume actively monitoring the SCBA for movement.
- If the SCBA cylinder is turned off and depressurized without rendering the alarm sensor inactive (pressing the Reset button twice), the PASS will continue to monitor motion in sensing mode.
- Resetting the full alarm after the SCBA has been depressurized will not turn off the PASS.

---

## Low Battery

In a low-battery condition, the PASS will produce a single audible chirp from the Sensor Module once every two (2) seconds and the green PASS Signal light on the control module will not flash.

In a low-battery condition, the PASS will not emit the 3 beeps when cylinder valve is activated.

While in a low-battery condition, the PASS will continue to operate for a period of time greater than the longest duration cylinder available for the SCBA. However, the batteries must be replaced before the SCBA is used again. See the Battery Replacement section of these instructions.

If batteries are completely discharged or have not been installed, there will be no light or sound and the unit will not operate.

---

## Battery Test

When the PASS is in the off condition (cylinder valve closed, SCBA fully depressurized with no flashing lights), the batteries in the entire system can be checked by depressing the yellow Reset button on the console.

The green PASS Signal light will illuminate on the Advanced Electronics Console, if there is sufficient battery power remaining.

The red PASS Signal lights indicates that the batteries are low and must be replaced before the SCBA is to be used again.

If a low battery message occurs, all batteries must be changed before the SCBA is used again. See the Battery Replacement section of this instruction for details.

---

## Data Logging Feature

The XD SCBA is compliant with NFPA 1982, 2018 Edition. The PASS includes on-board electronics which maintain a running log of event data including start-up, shutdown, and PASS activation. The data log can be retrieved using the provided hardware and software.

3M™ SCOTT™ PERSONAL ALERT SAFETY SYSTEM (PASS)

## 3M™ SCOTT™ PAK-TRACKER LOCATOR SYSTEM

### Introduction

The 3M Scott Pak-Tracker Locator System (the Locator System) is a two-part electronic system consisting of a radio transmitter integrated into the Advanced Electronics Control Console and a directional Handheld receiver (HHR) used to locate the signal coming from the transmitter. An SCBA equipped with the Locator System will have two piezos with red labels located on the Sensor Module. When pressurized, there must be movement of the SCBA at least every twenty (20) seconds or the PASS device will again go into pre-alarm followed by full alarm as described above.

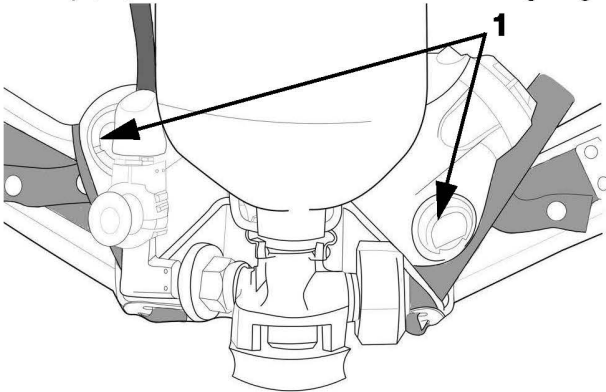

1	Piezos location on the Sensor Module
2	Handheld Receiver

### Operation

Use of this Locator System must be part of a complete personnel accountability system that includes procedures for monitoring the deployment and condition of all users. Do not rely on the Locator System as the only technique for locating missing personnel.

Failure to use this equipment properly may increase the time needed to locate and rescue personnel. **Training and practice in realistic emergency simulations is required before use of the equipment in an actual emergency.** The users must become thoroughly familiar with the operation and the limitations of the Locator System before entering a potentially hazardous or life-threatening situation.

The Locator System transmitter is activated with the PASS alarm. The transmitter emits a radio signal with a unique ID number that can be tracked using the HHR unit. The HHR is then used as a directional receiver to assist in leading the rescue team to the activated transmitter.

By pointing the HHR in the direction of the strongest relative signal, the rescue crew can follow the signal toward the SCBA user who is incapacitated or in need of assistance.

Understanding how the radio signal from a Transmitter behaves and how the HHR receives and displays the strength of that signal is critical to understanding the operation of the Locator System. Successful operation of the Locator System depends heavily on the interpretation of the relative signal strength information displayed on the HHR along with all other available information about the possible location of the activated transmitter.

The HHR is very sensitive in responding to small differences in signal strength. The relative strength of the Transmitter signal detected by the HHR will vary depending on:

- The distance from the transmitter to the HHR
- The path the transmitter signal has taken to get to the HHR
- The materials between the transmitter and the HHR that may affect the signal from the transmitter
- The user of the HHR must interpret the readings on the HHR display along with other information, such as:
  - Training and knowledge in systematic search and rescue techniques
  - Their sense of sight (watch where you are going)
  - Their sense of sound (listen for an activated PASS)
  - The last known location of the missing personnel
  - Knowledge of the building layout and building materials

Do not rely solely on the readings from the HHR to locate the activated transmitter. Refer to the user instructions provided with your Pak-Tracker equipment for complete details on the use of the Pak-Tracker System.

---

### **Use as part of an accountability system**

- A Rapid Intervention or Rescue team using the HHR should have a minimum of two (2) people.
- For their own safety, the team members should pay attention to their surroundings at all times while using the Locator System.
- The accountability system should include procedures for alerting the incident commander and rescue teams when actuated transmitters or the missing personnel have been found or when they have moved from their previous location.
- It is the responsibility of the personnel accountability system to allow for such contingencies without exposing individuals and teams to unnecessary dangers.

---

### **Detecting and avoiding radio frequency interference**

When any electronic device is adversely affected by radio waves, radio frequency interference (RFI) is said to have occurred. All electronic devices like the PASS may be subject to the effects of RFI. Radio transmissions from the antennas of radios including those used by firefighters, police and other public safety related personnel may produce RFI in the sensor module. RFI may occur while the radio is transmitting if the SCBA equipped with the PASS is in close proximity to a base station or high-powered vehicle mounted radio, or if the antenna of a personal portable handheld radio is touching or within six (6) inches of the Control Console or Sensor Module of the PASS.

A PASS affected by RFI may temporarily give false indications, such as the sudden sounding of the loud continuous three-tone chirp of the full alarm. In some instances, the lights on the control console may flash without sounding the alarm. In rare circumstances, a sounding alarm may stop. If the PASS exhibits any of the symptoms of RFI, identify the source of the RFI and do the following:

- If the symptoms of RFI occur when standing near a base station transmitting antenna or a truck mounted radio antenna, move away from the antenna until the symptoms stop.
- If the symptoms of RFI occur while transmitting on a hand-held radio, move the radio away from the sensor module.

Check the Control Console and be certain the green light is flashing normally when the interference stops, regardless of the source.

## DETECTING AND AVOIDING RADIO FREQUENCY INTERFERENCE

In normal usage with the air cylinder open, the PASS will typically resume normal operation after experiencing RFI.

If the PASS is affected by RFI when the SCBA air supply is turned off or the cylinder is empty, the PASS could be turned off during use. If this occurs, depress the RED Manual Alarm Button to activate the alarm.

If the symptoms of RFI occur, check the PASS to verify that it is functioning properly. If the green light on the Control Console does not resume flashing in the normal manner after experiencing the systems of RFI, or if the unit continues to malfunction in any other way, proceed to a safe area, remove the SCBA from service and tag it for repair by authorized personnel.

If the HHR experiences RFI, it may be necessary to remove the HHR from service. In a known safe, non-hazardous area, remove and reinstall the batteries to reset the unit (see the Battery Replacement section of the Pak-Tracker User Instructions, 3M Scott P/N 595278-01). Then inspect and return the HHR to service.

### Keep Radio Antennas at least six (6) inches from these areas:

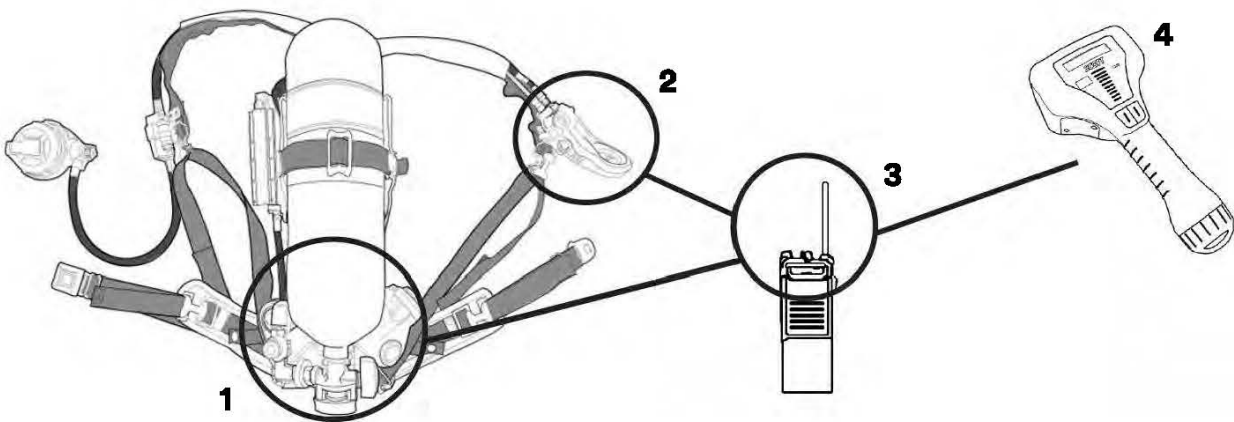

Table 2-1 RFI Warning Areas

1	Sensor Module
2	Control Console
3	Radio Antenna
4	Handheld Receiver

For more information about using the Locator System (including use with an SCBA, system limitations, and maintenance), refer to the Pak-Tracker User Instructions, P/N 595278-01. Copies of the User Instructions are available from the company or your authorized 3M Scott distributor.

3M™ SCOTT™ PAK-TRACKER LOCATOR SYSTEM



# 3M SCOTT ADVANCED ELECTRONICS AND TELEMETRY SYSTEM

---

## Introduction

These instructions explain the operation and use of the main functions of the 3M Scott Advanced Electronics Telemetry System. Follow the Regular Operational Inspection procedure as described. If any function fails to operate as described, do not use the equipment. Remove the unit from service and tag for repair by authorized personnel.

This system allows for wireless communication between the 3M Scott Air-Pak XD SCBA equipped with Advanced Electronics and the Base Station.

Complete training in the use of the Advanced Electronics equipment is required before actual use in a hazardous environment. If the equipment does not work as described in these instructions, remove the equipment from service and tag it for repair by authorized personnel.

---

## Advanced Electronics Overview

The Advanced Electronics System is a wireless network that provides monitoring of and communication between an SCBA user in a hazardous area and an incident commander or other designated person outside the hazardous area using the Advanced Electronics Base Station (Base Station).

The Base Station is comprised of the 3M Advanced Electronics Gateway, 3M Scott Monitor Telemetry Software (Monitor), and a Windows Operating System (Windows OS) Personal Computer (PC).

Advanced Electronics-equipped SCBA provide continuous, limited two-way communication between the SCBA Control Console and the Base Station when activated.

---

## Additional system components

### Advanced Electronics Control Console

The Advanced Electronics Control Console is integrated into the 3M Air-Pak XD as a part of the remote air pressure gauge assembly which hangs over the right shoulder of the SCBA user. The Shoulder console is equipped with a wireless transceiver for data communication between the SCBA user and the Base Station.

### Advanced Electronics Gateway

USB transceiver that receives data from up to a maximum of 60 SCBA with Advanced Electronics Control Consoles for visualization and management using the Base Station.

### Programmable ID Tags and Programming Equipment

## 3M Scott Monitor Telemetry Software

For more information on the Monitor Telemetry Software Solution please refer to the Base Station section below.



### NOTE

Advanced Electronics-enabled SCBA have bidirectional communication capabilities and can both transmit and receive data between the Control Console and the base station.

---

## Additional Features Added to the Console

- Gray button to activate withdraw or scan an ID card
- Icons indicating air supply, activation of a PASS alarm, initiation of commands by the user or the incident commander, and Base Station and two-way radio connection status

---

## System Operation

The following section describes the features of the Advanced Electronics SCBA Telemetry System. Training is required before use of this equipment. Use of this equipment must be part of a complete incident management and personnel accountability program.

When a SCBA user opens the cylinder valve and begins use of a 3M Scott Air-Pak XD SCBA equipped with Advanced Electronics, the Advanced Electronics will automatically begin to operate. If Monitor Telemetry Software is running and the Advanced Electronic Gateway is also connected to the Windows OS Based PC or Tablet, when SCBA use begins, the SCBA will attempt to connect to the Advanced Electronics Gateway. The Incident Commander(s) are responsible for coordinating activities with each other and to maintain accountability for all participating firefighter resources.

For more information, see the 3M Scott Monitor Telemetry Software Installation & Use User Instructions (P/N 595355-01) or the 3M Scott Monitor Quick Reference Guide available within the software application and for complete details of computer requirements, software setup and use.

## Console Buttons

There are three (3) buttons on the Advanced Electronics Control Console: The gray button added to the left side of the Control Console allows the user to call for a Withdraw from the IDLH environment without having to use the radio. To activate the function the user needs to press and hold the button for approximately three (3) seconds. The gray button is also used to allow the user to register a personal ID in to the SCBA by use of an ID card.

The Yellow button, used to reset the PASS alarm and shut down the electronics, has the additional function of allowing the user to acknowledge commands sent from the Base Station in the same manner as resetting the PASS alarm.

**Advanced Electronics Control Console**



1	Air Pressure Gauge	5	Withdraw Button (Gray)
2	Front-facing Buddy Light	6	PASS Signal Light
3	Console Display	7	Manual Alarm Button (Red Button)
4	Reset Button (Yellow button)	8	Ambient Light Sensor

**Evacuation (EVAC)/Withdraw**

The EVAC/Withdraw symbol lights in the following situations:

- The Base Station sends a call to the user(s) to evacuate (flashing red) or the user acknowledges the EVAC command (solid red).
- The user presses the Withdraw button on the Control Console (flashing yellow) or the Base Station acknowledges the Withdraw request (solid yellow).



**Range**

The Range symbol light flashes yellow when out of range of the Base Station, and solid green when in range and connected to a Base Station. The Base Station displays a similar message.



**PASS Alarm**

The PASS Alarm symbol lights when the user’s PASS is activated. The Base Station displays a similar message.



**ID LED**

The ID symbol lights in the following situations:

- The console is in the ID programming mode (solid green) or the input from the user’s accountability tag has been accepted (flashing green).
- An ePAR command has been initiated by the Base Station (flashing yellow) or the ePAR command has been acknowledged by the user (solid yellow).



## Console Operations

The Activation, PASS, and Deactivation are the same for the Advanced Electronics Console as stated above in the PASS Operations Section.

**Initialization and Range:** After the start-up sequence, the SCBA will send an initialization signal to the Base Station. When an Advanced Electronics-equipped SCBA is searching for a connection to the Gateway, the Range symbol on the Control Console will flash yellow.

When a connection is made with the Gateway, the Range symbol on the Control Console will turn to solid green.

When an Advanced Electronics-equipped SCBA loses contact with the Gateway, the Range symbol on the Control Console will flash yellow, indicating the user is out of range and will flash until it can reestablish connection to the Gateway.

Except for those functions which involve communication, all PASS functions of the Advanced Electronics Control Console are still operational when the SCBA is either out of range or not connected to a Base Station or radio.

If PASS on the SCBA is activated, the Control Console it will send a signal to the Base Station. This signal will override all other messages and actions of the Control Console and the PASS symbol will flash red. When the Base Station acknowledges the user's signal, the PASS icon on the Control Console will turn solid red but will not disable the audible alarm.

If the SCBA users are required to leave the hazardous area, the Base Station operator can send an EVAC message to the Control Consoles of logged-in SCBA users.

When this occurs, the user will see and hear the following:

- The Sensor Module will begin to Alarm
- The EVAC Icon will begin flashing Red on the Console

To silence the Alarm double click the Reset button. This will change the EVAC Icon solid Red and mark that you acknowledged the request on the Base Station.

To clear the EVAC request completely, the SCBA needs to be deactivated by following this process.

The SCBA user may choose to leave the hazardous area. Pressing and holding the gray Withdraw button for at least two seconds will send a withdraw request to the Base Station. This activates the following processes: "**Deactivation**" on page 10.

- The EVAC symbol on the Control Console will flash yellow quickly.
- The Base Station will receive the request and prompt the person operating that you have requested to withdraw.
- When Base Station Operator acknowledges the withdraw request, the EVAC symbol on the Control Console will turn solid yellow and remain on until the user leaves hazardous area and deactivates the SCBA.

In addition to the other end-of-service time indicators (EOSTI) on the SCBA, the Vibralert in the regulator indicates a low air warning by vibrating the regulator and making an audible alarm when the cylinder pressure reaches one third of the rated SCBA pressure.

---

## Base Station Definition and Operation

The Advanced Electronics Base Station consists of our Monitor Telemetry Software Solution, Advanced Electronics Gateway, and a Windows OS PC that meets the requirements of the software.

---

## Monitor Telemetry Software Solution

Is designed to provide incident commanders or other responsible parties with critical, real-time information from Advanced Electronics-equipped SCBA in use on an emergency scene. The system can monitor each SCBA air supply level, PASS activation, Withdraw requests, initiate and monitor EVAC calls. The application uses a point-to-point wireless network for bi-directional communication of acknowledgments between the application and SCBA users. Users of this system must be familiar with the capabilities and limitations of the system. The system is intended to be used as an integral part of an emergency event management system, which includes planned deployment of personnel.

Requirements to use Monitor Telemetry Software include the following:

- 3M Scott Air-Pak XD, equipped with Advanced Electronics
- A personal Windows Operating System based computer or tablet (not included) with Monitor installed
- Advanced Electronics Gateway with USB Interface

Monitor Telemetry Software is intended to supplement, not replace, your standard operating procedures for emergency incident management. The incident commander must maintain an awareness and control of all firefighter resources participating in the incident. This software does not replace conventional two-way radio communications. This software does not replace the minimum recommended interior firefighting crew requirements as set forth in any NFPA or Regulatory Standard governing the fire service.

Monitor Telemetry Software must be operated by a fully trained individual as part of a complete incident management system and respiratory protection program. The Base Station Operator must have the ability to notify other personnel if an emergency situation develops as displayed by the Advanced Electronics Telemetry System.

Active Advanced Electronics-equipped SCBA users can send signals to and receive signals from the Base Station. The Base Station operator must monitor and respond to any Active Alerts in accordance with the organization's event management program. This may include issuing an ePAR or EVAC signal to an individual or to the entire team.

### Monitor Advanced Electronics-equipped SCBA for the following active alerts:

- **Mid Air Level or Low Air Level** - When the air supply cylinder reaches predetermined pressure, a Mid or Low Air Level signal will transmit to the Base Station, which will display the air level for that SCBA and sound an audible alarm. For low air pressures, the EOSTI will activate on the SCBA. (The Low Air Level alert **cannot** be disabled using Monitor.)
- **PASS Alarm Active** - When a user's PASS has been activated, the PASS signal will be sent to the Base Station, which will display "PASS Alarm Active" for that SCBA and sound the PASS audible alarm. The alarms will continue until the PASS is turned off on the SCBA. (The PASS Alarm Active alert **cannot** be disabled using Monitor.)
- **Out-of-Range** – Status of the communication link to the Base Station. The Out-of-Range alert will begin after forty (40) seconds without a signal from the Advanced Electronics-equipped SCBA to the Base Station. The Base Station will display "Out of Range" for that SCBA and sound the Out-of-Range caution audible alarm, indicating the system is trying to re-link with the user. The Base Station operator must respond to the user's Out of Range signal in accordance with the organization's event management program.
- **Withdraw Notification** - A user chooses to withdraw by pressing the gray button on the Advanced Electronics Control Console on the SCBA. When this occurs, the Withdraw request is sent to the Base Station, which displays "Withdraw Requested" and sounds the Withdraw audible alarm.
- **System Integrity Alarm (EVAC)** - When the temperature of the SCBA's on-board electronics exceeds an established threshold (approximately 176° F), the SCBA displays the EVAC symbol in solid red on the Control Console and transmits the message to the Base Station, which displays "**System Integrity Alarm**" for that SCBA and sounds an audible alarm. The EVAC symbol remains illuminated, and the alarm continues to sound until the temperature drops below the threshold.



- Send an **ePAR (ID)** to all active or selected Advanced Electronics-equipped SCBA users as needed for personnel accountability.
- Send an **Evacuation (EVAC)** to all active or selected Advanced Electronics-equipped SCBA users when required.
- **Support Personnel Accountability** - The Base Station operator must monitor and coordinate the activities of non-Advanced Electronics-equipped SCBA users who have logged into the system using RFID Tags in accordance with the organization's event management program.



**NOTE**

Advanced Electronics-equipped SCBA can initially take approximately forty (40) seconds to two (2) minutes to connect to the base station. Connection time may increase as the number of additional external devices increases.

The EVAC/Withdraw, PASS, and Range icons that appear on the software display are the same as the EVAC/Withdraw, PASS, and Range symbols that appear on the Advanced Electronics Control Console display.

Accessibility to some settings may be limited by your system administrator to maintain compliance with applicable national standards or established internal procedures.

---

Prior to activation of the System Integrity Alarm on the SCBA the Base Station will initiate a Pre-Alert. This occurs when the Control Console internal temperature sensor reaches approximately 170° F. This notification allows time for the Base Station Operator to decide whether to evacuate the SCBA user.

## CLEANING AND MAINTENANCE

---

### Regular Operational Inspection

Inspect and test the PASS, Advanced Electronics Telemetry System, and the Locator System along with the inspection and test of the 3M Scott Air-Pak XD SCBA before each use. Refer to the Pak-Tracker User Instructions (P/N 595278-01) provided with the HHR for complete details.

Include the following inspection procedures with the regular operational inspection procedures defined in your SCBA instructions. If any malfunction of the SCBA, the PASS device, the Locator System, or the Advanced Electronics Telemetry System is noted during the inspection, remove the SCBA from service and tag it for repair by authorized personnel.

To test the Pak-Tracker locator transmitter, you must have an operating HHR.

**NOTE**

If this inspection is done in direct sunlight, it may be helpful to shade the lens on the control console with your hand to be sure the lights are flashing as described.

**NOTE**

In several of the inspection procedures described, a full alarm will be observed. The full alarm condition includes an audible tone that can exceed 95 dBA at 3 meters (9.9 ft.). To prevent possible hearing damage during test, immediately reset the alarm on verification that it is functioning properly. Wear hearing protection if prolonged or repeated exposure to a full alarm condition is anticipated.

**NOTE**

The performance properties of the PASS device cannot be properly tested in the field.

- 
- 1 While performing the visual inspection of the SCBA, visually inspect all PASS enclosures, lenses, and wire conduits for cracks, wear or other damage. If any damage is found, remove the SCBA from service and tag for repair by qualified personnel.
  - 2 Inspect the HHR for any cracks or signs of damage. If any damage is found, remove the unit from service and tag it for repair by qualified personnel.
  - 3 Turn on the HHR according to the operating instructions provided with the unit. Position the HHR nearby.
  - 4 Activate the Base Station if system is equipped with Advanced Electronics and position the PC or Tablet nearby.

## CLEANING AND MAINTENANCE

- 5 With the cylinder valve closed, press the manual alarm button, located on the front of the Control Console.
  - a The manual alarm sounds a loud repeated pattern of an ascending tone, followed by an alternating tone accompanied by flashing of the red PASS signal lights on the Control Console.
  - b The HHR sounds an alarm and displays the unique identification number of the PASS. Use the Scroll button on the HHR to highlight the active ID number and press the Enter button on the HHR to select the displayed ID number. Point the unit directly at and near the SCBA. The signal strength displayed will be at its highest value.
  - c Verify that the Advanced Electronics functions (if present) are all operating properly and that PASS alarm, EVAC alarm, and acknowledgments operate according to these instructions.
- 6 Reset the manual alarm by pressing twice on the yellow Reset button.
  - a The unit will sound three chirps and the green PASS Signal light will flash.
  - b The HHR will reset to its non-alarm state.
- 7 Close the cylinder valve and depressurize the SCBA. Turn off the PASS by pressing the yellow Reset button twice. The unit will sound a two-tone chirp and the green PASS signal light will go out.
- 8 Open the cylinder valve to pressurize the SCBA system. The PASS sounds (three) 3 quick chirps and the light on the Control Console flashes green about once per second. The (three) 3 chirps will sound at approximately the same time the Vibralert in the mask-mounted regulator actuates briefly. Make sure the air flow is stopped by pressing the air saver/donning switch.
- 9 To check the pre-alarm, leave the SCBA motionless for twenty (20) seconds. The flashing green PASS Signal light is replaced by the flashing red PASS lights. An ascending/descending tone sounds, increasing in volume. Leave the SCBA motionless.
- 10 After the pre-alarm condition occurs, check the pre-alarm reset by moving the SCBA to activate the motion sensor. The PASS should reset to sensing mode. The flashing red PASS Signal light is replaced by a flashing green PASS light and the ascending/descending tone stops.

Continue with the regular operational inspection of the SCBA as directed by the SCBA instructions or your approved respiratory protection plan procedure. During the inspection, the SCBA must be moved or turned every thirty (30) seconds or less to prevent the sounding of the full alarm.

### **After completion of all SCBA checks and before turning off the cylinder valve:**

- 1 Check the manual reset of the pre-alarm. Leave the SCBA motionless until pre-alarm condition occurs. Within twelve (12) seconds press and click the yellow Reset button **once**. Three (3) chirps sound. The PASS resets to sensing mode.
- 2 To check the full alarm, leave the SCBA motionless until the pre-alarm condition occurs. Do not reset. Allow the SCBA to progress for approximately twelve (12) more seconds at which time the SCBA will go into full alarm.
  - a The full alarm sounds a loud, repeated pattern of ascending tone, followed by an alternating tone, accompanied by simultaneous flashing of the red PASS Signal lights.
  - b The HHR sounds an alarm and displays the identification number of the PASS device. The displayed number will be either the Sensor ID number which appears on the label on the Sensor Module, or the ID number programmed using the Advanced Electronics RFID Tag. Use the Scroll button on the HHR to highlight the active ID number and press the Enter button on the HHR to select the displayed ID number. Point the unit directly at and near the SCBA. The signal strength displayed will be at its highest value.
- 3 Reset the full alarm by pressing **twice** on the yellow Reset button.
  - a The loud alarm stops. The unit resets to sensing mode.
  - b The HHR resets to its non-alarm state.



- 4 Finish all SCBA checks involving air flow and turn off the cylinder valve. Use the purge valve to release all residual air pressure in the system.

**With the cylinder valve closed (off):**

- 1 Check the continuing operation of the PASS. The PASS remains active with the green PASS Signal light flashing. Do not move the SCBA; pre-alarm occurs within twenty (20) seconds. Move SCBA slightly; pre-alarm resets and the green PASS Signal light starts flashing again.
- 2 To turn the PASS off, press the yellow Reset button **twice**.



**NOTE**

If the low battery indication (one steady chirp every two (2) seconds with no flashing lights) occurs at any time during the Regular Operational Inspection and was not initiated by pressing the yellow Reset button twice while the SCBA was pressurized, do not use the SCBA. Change the batteries in the Sensor Module immediately and repeat the Regular Operational Test or take the SCBA out of service until the batteries are changed and the Regular Operational Test is successfully performed.

If any operational problems are found during the Regular Operational Inspection, do not use the SCBA. Remove the SCBA from service and tag it for repair by authorized personnel.

## Operation of Sensor Module Lights

When performing the Regular Operational Inspection verify that the Sensor Module lights are operating as described below:

Action or Situation	Behavior of Lights
Start Air-Pak SCBA (i.e., open cylinder valve)	Bright light, then flashing green light
Normal operation	Flashing green light
Air cylinder between 1/2 and 1/3 full	Flashing yellow light (2 quick flashes) every second
Air cylinder less than 1/3 full (low air)	Flashing yellow light (alternately)
Low battery while unit is on	Flashing yellow light once every 2 seconds
Shut down	Off
Press Reset button on Control Console with unit off (battery test)	Good battery: Bright light, then flashing green light Low battery: Bright light, then flashing red light
Press Manual alarm button on Control Console with unit off	Flashing red light (simultaneously)
Press Reset button on Control Console during full alarm	Flashing green light
PASS pre-alarm	Flashing red light (alternately)
PASS full alarm	Flashing red light (simultaneously)

## Cleaning, Maintenance, and Storage

Cleaning, maintenance and storage of an SCBA with a PASS device is part of the normal SCBA Cleaning and Storage and Regular Operational Inspection as described in the User Instructions supplied with each 3M Scott Air-Pak XD.

Refer to the Pak-Tracker User Instructions (P/N 595278-01) provided with the HHR for complete details of cleaning and storage of the HHR.

Store the SCBA in accordance with the User Instructions provided with the SCBA. Do not store SCBA equipped with PASS in the proximity of radio antennas or radio transmitter base units. SCBA equipped with PASS must be stored or

## CLEANING AND MAINTENANCE

transported at least two (2) feet away from radio antennas on fire equipment. Refer to the Detection and Avoiding Radio Frequency Interference section of this instruction for details.

Clean the exterior of the Control Console while cleaning the exterior of the SCBA by wiping with a damp sponge and thoroughly wiping dry. The Signal Light lens on the front of the Control Console should be cleaned after every use to ensure maximum light intensity at all times. Do not use solvents for cleaning or attempt to paint or apply decals to the exterior surfaces of the Control Console.

If during use, the SCBA and/or Control Console is suspected of being contaminated by a hazardous substance, the contaminant must be identified and properly removed, or the contaminated component(s) must be replaced before next use. Dispose of the contaminant or the contaminated component(s) in accordance with applicable regulatory requirements.

Except for the replacement of batteries, no attempt shall be made to do maintenance or to make adjustments or repairs beyond the scope of this user instruction without proper training.

---

## Marking and Painting

Do not mark, etch, paint, drill, or apply any non-approved labels to any of the PASS components or housings in any way.

---

## Replacement Parts and Service

Consult your authorized 3M Scott representative, distributor, or service center as to the availability of service and parts for the PASS device. Replacement batteries of the type designated are commercially available, from your authorized distributor, and from most industrial battery distributors. The device must be mounted and oriented by a Certified Technician II to ensure correct mounting and orientation.

Except for the replacement of batteries, do not attempt to perform maintenance or to make adjustments or repairs beyond the scope of this user instruction without proper training.

---

## Retirement Criteria and Consideration

Retirement criteria and considerations to be determined by technicians with Certified Technician II qualifications in accordance with NFPA 1852.

---

## Battery Replacement

An SCBA equipped with a PASS requires six (6) "AA" cell batteries for operation. The six (6) batteries power the Heads-Up Display, the PASS, and the Locator System transmitter. The batteries should be replaced only by a trained maintenance technician in a clean area known to be nonflammable.



### NOTE

Always be sure that the cylinder valve is off and the PASS device is completely inactive before changing batteries. Never remove or replace batteries when the system is pressurized or damage may occur to electronic components.

---

**Replace batteries as follows:**

- 1 Ensure the SCBA is fully depressurized and the SCBA electronics are turned off before attempting to replace the batteries.
- 2 When replacing batteries on SCBAs, remove the cylinder and place the SCBA in a clean, non-hazardous area.
- 3 Use a Phillips driver to remove the Battery Housing Cover. Carefully remove the cover and set aside.
- 4 Remove the used batteries by sliding them out of the battery compartment.



- 5 Install six (6) fresh new "AA" batteries of the same type. Always replace all batteries at the same time. The battery holder is marked with the style and orientation of the batteries required. To maintain intrinsic safety, use 6 approved AA batteries from our approved battery list:

<https://multimedia.3m.com/mws/media/2192836O/3m-scott-scba-and-accessories-approved-battery-list.pdf>

**Do not mix batteries.** Verify the correct orientation of batteries as shown on label inside the battery holder.

- 6 The battery cover must be installed so that it is water-tight after replacement. Clean the sealing rib around battery compartment and the sealing face of the cover by wiping with a clean damp cloth to remove any dirt or foreign matter that might prevent a proper seal. Check the cover gasket for tears or cuts. If damage is found, remove the SCBA from service and tag it for repair by authorized personnel.
- 7 To install battery cover, align the three grooves on the cover with the three tabs on the battery compartment and torque the cover screw to 20 in-lbs. The cover must be water-tight to prevent damage to the equipment.
- 8 To test the batteries, verify that the SCBA electronics are in the off condition (cylinder valve closed with no flashing green LED on the control console).
  - Press and hold the reset button on the console. A green light on the console indicates sufficient battery power and that the batteries are properly installed.
  - If the unit displays the Low Battery condition or no light at all, verify that the batteries are properly installed. If the batteries were properly installed, remove the batteries and replace with a new set of six (6) batteries.
  - If another set of properly installed batteries will still not produce a green light on the battery test, remove the unit from service and tag it for repair by authorized personnel.





## Safety Listings

---

### Compliance

#### FCC and ISSED Radio Frequency Rules and Regulations

This device complies with Part 15 of the FCC Rules and with ISSED's license-exempt RSS's standards. Operation is subject to the following two conditions:

- (1) This device may not cause harmful interference, and
  - (2) This device must accept any interference received, including interference that may cause undesired operation.
- (1) l'appareil ne doit pas produire de brouillage, et
  - (2) l'utilisateur de l'appareil doit accepter tout brouillage radioélectrique subi, même si le brouillage est susceptible d'en compromettre le fonctionnement.

This equipment has been tested and found to comply with the limits for a Class A digital device, pursuant to part 15 of the FCC Rules. These limits are designed to provide reasonable protection against harmful interference when the equipment is operated in a commercial environment. This equipment generates, uses, and can radiate radio frequency energy and, if not installed and used in accordance with the instruction manual, may cause harmful interference to radio communications. Operation of this equipment in a residential area is likely to cause harmful interference in which case the user will be required to correct the interference at his own expense.

#### CAN ICES-3 (A)/NMB-3(A)

**Warning:** Changes or modifications to this device shall not be made without the written consent of the 3M Company. Unauthorized modifications may void the authority granted under Federal Communication Rules permitting the operation of this equipment.

SCBA Advanced Electronics Console  
FCC ID:DGF SCOTT41367  
IC: 458A-SCOTT41367  
Advanced Electronics Gateway  
FCC ID: GFPSD225B IC: 458A-PSD225

---

### RF Exposure Information

Electronic Console and Electronics Gateway have been tested and meet applicable limits for Radio Frequency (RF) Exposure. They were designed and manufactured not to exceed the emission limits for exposure to radiofrequency (RF) energy set by the Federal Communications Commission of the U.S. Government. These limits are part of comprehensive guidelines and established permitted levels of RF energy for the general population. The guidelines are based on standards that were developed by independent scientific organizations through periodic and thorough evaluation of scientific studies. The standards include a substantial safety margin designed to assure the safety of all persons, regardless of age and health. The exposure standard for wireless devices employs a unit of measurement known as the Specific Absorption Rate, or SAR. The SAR limit set by the FCC is 1.6W/kg. Tests for SAR are conducted using standard operating positions specified by the FCC with the device transmitting at its highest certified power level in all tested frequency bands. Although the SAR is determined at the highest certified power level, the actual SAR level of the device while operating can be well below the maximum value. The tests are performed in positions and locations (e.g., next to the head and body) as required by the FCC for each model. SAR information on this model device is on file with 3M Company.

This Self-Contained Breathing Apparatus (SCBA) logs data and records events with an associated date and time stamp. To ensure the date and time stamp are correct the internal clock needs to be set to the local personal computer (PC) time using by 3M Scott Configure XD Software (<https://download.3m.com/>) and a Pak-Link Programmer device. Once the initial date and time are set after initial purchase we recommend they be updated at least bi-annually (eg. when Daylight Saving Time starts and ends).

Component	Model No.
Sensor Module	201846-01
Console assy 4500	78-8151-4133-4
Console assy 5500	78-8151-4134-2
Console assy 4500 telemetry	78-8151-4136-7
Console assy 5500 telemetry	78-8151-4137-5

---

## Handheld Receiver Non-Incendive Listing

The HHR (P/N 200397-04) is listed as Non-Incendive per ISA Std. 12.12.01 and UL 1604 for use in Class I Division 2 Groups A, B, C, and D hazardous locations. Temperature Code T4 (-25° C to 85° C). To maintain the Non-Incendive Listing, the equipment must be inspected regularly per the following Regular Operational Inspection procedures.

Do not tamper with or substitute components in any manner. Use only battery pack P/N 200402-02. Open the battery compartment only in an area known to be free of flammable or explosive hazards.

**WARNING – Substitution of components may impair the non-incendive listing.** To reduce the risk of ignition of a flammable atmosphere, battery must only be changed in an area known to be nonflammable. Do not substitute any other battery or power source.

---

## Personal or Tablet Computer

The personal computer and Base Station environmental operating parameters are totally dependent on the limitations of the personal computer or tablet used with the Advanced Electronics SCBA Telemetry System. Do not use the personal computer or Base Station in environments for which it is not designed. Handle the personal computer or tablet according to the instructions provided with the personal computer device.

---

## Export and Import

The international transport of this equipment and any related documentation is regulated under United States export laws and regulations and may be regulated by the import or export laws and regulations of other countries.

If you have any questions or concerns regarding these regulations, contact the company at +1-800-247-7257 (or +1-704-291-8300 outside the continental United States).

---

## End User License Agreement

Software and/or firmware incorporated in this 3M Scott product is subject to the terms of an End User License Agreement (EULA), which are stated in the software download and installation process.

**Quick Reference Guide**

<b>When you want to...</b>	<b>You do...</b>	<b>The PASS Does...</b>
Turn it on	Open cylinder valve (cylinder <u>must</u> have air in it).	3 quick audible chirps, green flashing light on Control Console.
Reset pre-alarm	Move so that the SCBA moves, or press the yellow reset button on the console.	Green flashing light replaces red flashing lights, alarm tones stop.
Reset full alarm	Press Reset button on Control Console twice (push, release, push again).	Audible alarm stops, 3 quick chirps sound, green light replaces red lights.
Turn it off (finished with use)	Close the SCBA cylinder valve, open the regulator purge valve to let out all the trapped air, close the regulator purge valve, press the Reset button twice.	The flashing light goes out. A descending two-tone chirp sounds.
Turn on the manual alarm	Press red alarm button on Control Console (works whether the PASS is on or off).	Goes into full alarm. Loud ascending then alternating tone sounds. Red, peripheral PASS Signal lights flash simultaneously, replacing green flashing light.

<b>When the PASS is...</b>	<b>It indicates that...</b>
Quiet. No lights or sound	The PASS is off or the batteries have an insufficient charge or have been removed.
Flashing the green light	The PASS is on, in automatic mode, and monitoring your motion.
Flashing red PASS Signal lights in an alternating pattern, and emitting an ascending/descending tone.	You have not moved in the last twenty (20) seconds. The PASS is demonstrating a pre-alarm.
Flashing red PASS Signal lights simultaneously, and emitting a loud, repeated pattern of an ascending tone followed by an alternating tone	You have not moved in the last thirty-two (32) seconds or more, or you pushed the manual alarm button, initiating a full alarm.
Chirping once every two (2) seconds with no light flashing	The batteries are low. You must put in new batteries before using the PASS again (it will work in low battery condition long enough to let you finish the cylinder of air you are on).





4320 Goldmine Road  
Monroe, NC 28110  
Telephone: +1 (704) 291-8300  
Toll-Free: +1 (800) 247-7257  
Web: [www.3M.com/ScottFire](http://www.3M.com/ScottFire)