

3M

Installation Instructions

Opticom™ GPS

Priority Control System

Vehicle Equipment

PRELIMINARY

Table of Contents

1 About This Manual..... 1

 1.1 Purpose of Manual..... 1

 1.2 Manual Conventions..... 1

 1.3 Manual Organization 1

2 Safety Information..... 2

 2.1 Intended Use 2

 2.2 Technical Support..... 2

 2.3 Safety Messages and Safety Labels..... 2

 2.3.1 Safety Message Format..... 2

 2.3.2 Safety Label Format..... 3

 2.4 Safety Messages Contained in this Manual..... 4

 2.5 Safety Label Locations 5

 2.6 Safety Considerations 6

 2.6.1 Personal Safety Equipment and Clothing 6

 2.6.2 Electric Shock 6

 2.6.3 Explosion 6

 2.6.4 Chemical Burns..... 6

 2.7 Disposal of Device..... 6

 2.8 FCC Statement..... 6

3 Description 7

 3.1 Opticom GPS System 7

 3.2 Vehicle Equipment 8

4 Features 10

5 Installation..... 11

 5.1 Radio/GPS Module Installation..... 12

 5.2 Control Switch Module Installation 13

 5.3 Final Vehicle Wiring 14

 5.4 Performance Tests 15

6 Maintenance 16

1. About This Manual

1.1 Purpose of Manual

This manual provides step-by-step instructions for installing the 3M™ Opticom™ GPS Priority Control System Vehicle Equipment. It is intended for use by installers, maintenance personnel, and others who are responsible for the installation and maintenance of the system.

1.2 Manual Conventions

The conventions listed in Table 1-1 help to make this manual easier to use by presenting a uniform approach to the descriptions, phrases, and nomenclature.

1.3 Manual Organization

This manual is divided into six sections.

Section 1. About This Manual

Contains information about the organization and content of this manual.

Section 2. Safety Information

Contains important information about the safety messages, safety labels, safety precautions, and procedures for installation of this device.

Section 3. Description

Briefly describes the vehicle equipment and their related system components.

Section 4. Features

Describes important features and characteristics of the vehicle equipment.

Section 5. Installation

Contains step-by-step installation instructions.

Section 6. Maintenance

Contains information and recommendations to ensure reliable system operation.

Table 1-1. Manual Conventions

Element	Convention	Example
Names	First or formal reference: initial caps	3M™ Opticom™ GPS Priority Control System Radio/GPS module
	Subsequent use or informal reference: Initial caps for <i>Model</i> , lowercase for remainder	Module
Feature names	Initial caps	the Disable feature
Switch position	Uppercase	the OFF position

2. Safety Information

We provide important safety information and warnings to assist you in understanding and avoiding potential harm to yourself, and possible damage to equipment, during the installation of 3M™ Opticom™ GPS Priority Control System equipment. Although we have included many potential hazards you may encounter during the installation of this equipment, we cannot predict all of the possible hazards and this list should not be a substitute for your judgment and experience.

Please read and observe all safety information and instructions in this manual before installing the system equipment. Also, save this installation manual and keep it near the equipment.

If you are unsure about any part of this installation or of the potential hazards discussed, please contact your supervisor immediately.

2.1 Intended Use

The system is intended to assist authorized priority vehicles through signalized intersections by providing temporary right-of-way through vehicle operator interface to the system and through the use of common traffic controller functions.

2.2 Technical Support

If you have questions about the system, its use, or operation, please contact your dealer or call the 3M Intelligent Transportation Systems Technical Service department at 1-800-258-4610.

2.3 Safety Messages and Safety Labels

We include safety messages and safety labels in this manual to help you protect your safety and the safety of others. This section contains important information to help you recognize and understand these safety messages.

Please read all messages before proceeding with the installation.

2.3.1 Safety Message Format

Safety messages are designed to alert you to potential hazards that can cause personal injury to you or others. They can also indicate the possibility of property damage.

Each safety message box contains a safety alert symbol (); one of three signal words: DANGER, WARNING, or CAUTION; and a safety message.

The signal words and symbols, and their meanings, are shown below:



DANGER means you and/or someone else WILL be KILLED or SERIOUSLY HURT if you do not follow these instructions.



WARNING means you and/or someone else MAY be KILLED or SERIOUSLY HURT if you do not follow these instructions.

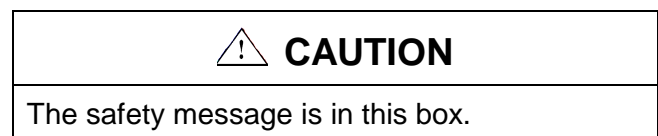

CAUTION means you and/or someone else MAY be HURT or property damage may result if you do not follow these instructions.

In addition to the symbols and words explained above, each safety message identifies the hazard, describes what you can and should do to avoid the risk of exposure to the hazard, and tells the probable consequences of not avoiding the hazard.

2.3.2 Safety Label Format

We include safety labels on the devices to help you protect your safety and the safety of others. Safety labels are designed to alert you to potential hazards associated with a piece of equipment that can cause personal injury to you or others. They can also indicate the possibility of property damage.

Please read all safety labels.

Each safety label contains a safety alert symbol (); one of three signal words: DANGER, WARNING, or CAUTION; a pictorial showing the nature of the hazard; and a safety message.

The signal words and symbols, and their meanings, are shown below:

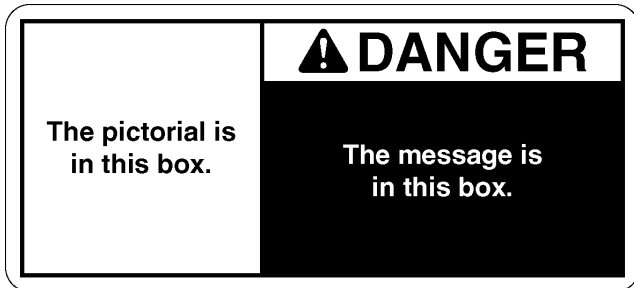

Opticom-242A

DANGER means you and/or someone else **WILL** be **KILLED** or **SERIOUSLY HURT** if you do not follow these instructions.

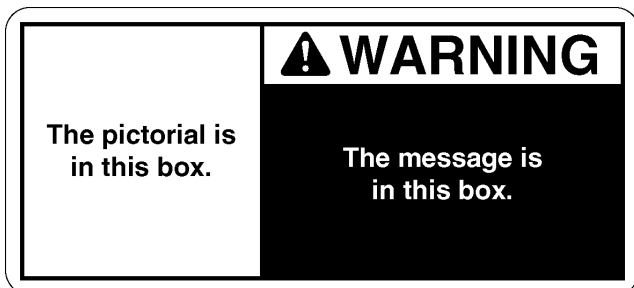

Opticom-243A

WARNING means you and/or someone else **MAY** be **KILLED** or **SERIOUSLY HURT** if you do not follow these instructions.

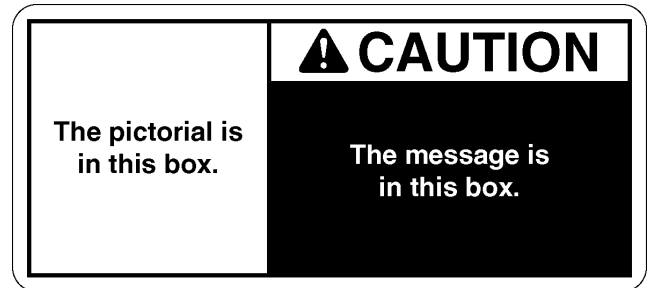

Opticom-244A

CAUTION means you and/or someone else **MAY** be **HURT** or **property damage** may result if you do not follow these instructions.

We consider safety labels to be an important part of all devices and they should be replaced immediately if they become hard to read.

If any of the safety labels are missing, or cannot be read, please contact your dealer or the 3M Intelligent Transportation Systems Technical Service department for a replacement.

2.4 Safety Messages Contained in this Manual

The following safety messages appear in this manual:

CAUTION

Modifying the Radio/GPS module may seriously damage the equipment and void the warranty. **Do not attempt to disassemble or modify the Radio/GPS module in anyway.** Modifying the radio and/or antenna in anyway may cause the radio to violate FCC requirements.

WARNING

Vehicle batteries contain sulfuric acid and may contain explosive gases. **Keep sparks, flames, and cigarettes away. Wear eye protection. Disconnect the negative cable first to prevent shorting the positive terminal to the chassis when removing the positive cable.** Battery acid may cause skin irritation and eye injury. Explosive gases may cause severe injury or death.

WARNING

A completed installation that is not tested may result in improper system operation, which may result in accidents and/or injuries. **To avoid this problem, test the system to verify proper operation.** Improper system operation may result in unsafe driver action.

2.5 Safety Label Locations

There are x safety labels.

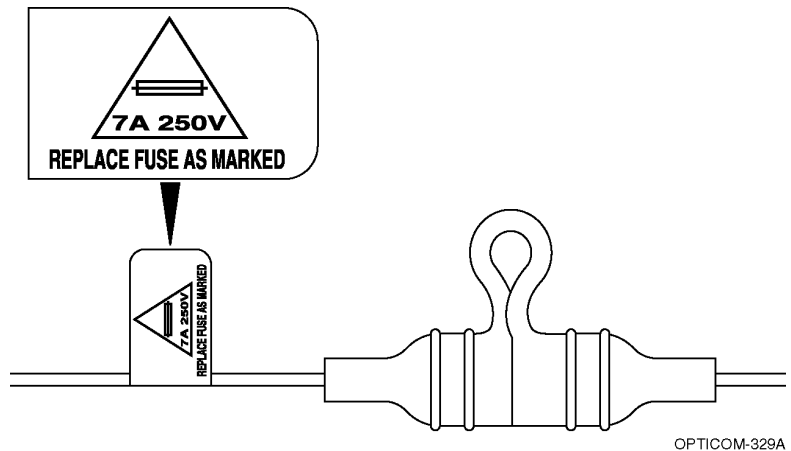

Figure 2-1. Vehicle Equipment Fuse Safety Label Location

2.6 Safety Considerations

Please consider the following safety issues before beginning the installation.

Although we have compiled this list of common safety considerations, it should not be considered as complete. It is not intended to take the place of your good judgment, training, and experience.

2.6.1 Personal Safety Equipment and Clothing

Personal safety equipment and clothing including high visibility vests, hard hats, gloves, electrical shock or electrocution protection clothing and equipment, safety shoes, safety glasses, face shields, goggles, and hearing protection devices are just some of the items available to you.

Choose the right equipment for the job. If you are unsure of which safety equipment is recommended or appropriate for the job, ask your supervisor or foreman.

2.6.2 Electric Shock

As a trained installer of electrical equipment you are aware of the dangers associated with installation of electrical devices. Always be sure that the power to the equipment, and all associated equipment, is turned off and the vehicle battery is disconnected. We also recommend that you wait for the period of time specified in the warning message before beginning any procedure. This waiting period is required to allow electrically charged components to discharge and minimize your exposure to the risk of electric shock and electrocution. Use the equipment, techniques, and procedures that you learned during your training or apprenticeship or other electrical industry recognized safety procedures.

If you are unsure of which techniques, procedures, and protective equipment are recommended or appropriate for the job, ask your supervisor or foreman.

2.6.3 Explosion

Common automotive-type batteries produce an explosive gas under some conditions. This gas may easily be ignited by a spark or flame as you work on the vehicle. To reduce the risk of explosion, disconnect the battery, work in a well ventilated area, avoid the use of devices that create sparks or use open flames, and use the appropriate personal safety equipment and clothing.

If you are unsure of which techniques, procedures, and protective equipment are recommended or appropriate for the job, ask your supervisor or foreman.

2.6.4 Chemical Burns

Common automotive-type batteries contain strong acid that can cause personal injury if you come in contact with the acid. To reduce exposure to the risk of chemical burns wear appropriate protective clothing and handle the battery with care.

If you are unsure of which techniques, procedures, and protective equipment are recommended or appropriate for the job, ask your supervisor or foreman.

2.7 Disposal of Device

Please dispose of the device in accordance with all local, state, and federal laws and regulations.

2.8 FCC Statement

This equipment has been tested and found to comply with the limits for a Class A digital device, pursuant to part 15 of the FCC Rules. These limits are designed to provide reasonable protection against harmful interferences when the equipment is operated in a commercial environment. This equipment generates, uses and can radiate radio frequency energy and, if not installed and used in accordance with the instruction manual, may cause harmful interference to radio communications. Operation of this equipment in a residential area is likely to cause harmful interference in which case the user is required to correct the interference at their own expense.

3. Description

This section provides a general description of the 3M™ Opticom™ GPS Priority Control System and a detailed description of the vehicle equipment

3.1 Opticom GPS System

The system assists authorized priority vehicles through signalized intersections by providing temporary right-of-way through the use of common traffic controller functions.

The Opticom GPS system consists of the following matched components:

- **Vehicle Equipment** —
 - Radio/GPS module containing a GPS receiver with antenna and a 2.4 GHz transceiver with antenna
 - Processing module
- **Intersection Equipment** —
 - Module containing a GPS receiver with antenna and a 2.4 GHz transceiver with antenna
 - **Phase Selector**
 - **Auxiliary Interface Panel**
 - **Card Rack/Input File**

The vehicle equipment, is mounted on the priority vehicle. Its GPS receiver receives position information from the constellation of GPS satellites. This information is used to compute the location, speed, and heading of the vehicle. This information along with a priority request and the state of the vehicle's turn signal is broadcast using the 2.4 GHz transceiver.

The intersection equipment receives this information. The intersection equipment then compares the information being received from the vehicle to the parameters stored in the intersection equipment's memory. If the vehicle is heading towards the intersection in a predefined approach corridor and is requesting preemption and has met all other programmed parameters, the corresponding phase selector output is activated. This output is then connected to the traffic controller preemption input. When activated, the controller will then cycle to grant a green light to the requesting vehicle or hold the green allowing the vehicle to pass through the intersection.

The card rack/input file provides the power and logic wiring for the phase selector, which plugs directly into a slot in the unit.

The auxiliary interface panel provides additional connection for monitoring green phases and also provides turn signal state dependent preemption outputs.

3.2 Vehicle Equipment

3M™ Opticom™ GPS Priority Control System Vehicle Equipment is a compact, weather-resistant, RF energy-emitting device. This equipment is intended for use on priority vehicles. The equipment consists of a module containing a GPS receiver with antenna and a 2.4 GHz transceiver with antenna, as well as a processing module, which also provides an interface point between the vehicle equipment, the vehicle wiring, and an external PC used for configuration, diagnostics, and downloading log information.

Please be aware of the following operational characteristics of this equipment.

Appropriate vehicle Class and ID numbers are determined at the time of installation and are programmed by the user via Configuration software.

The optional Disable feature uses an additional switch (customer supplied) that connects to battery negative or positive when actuated.

This manual describes how to install vehicle equipment

Figure 3-1 shows a typical vehicle equipment installation for a priority vehicle.

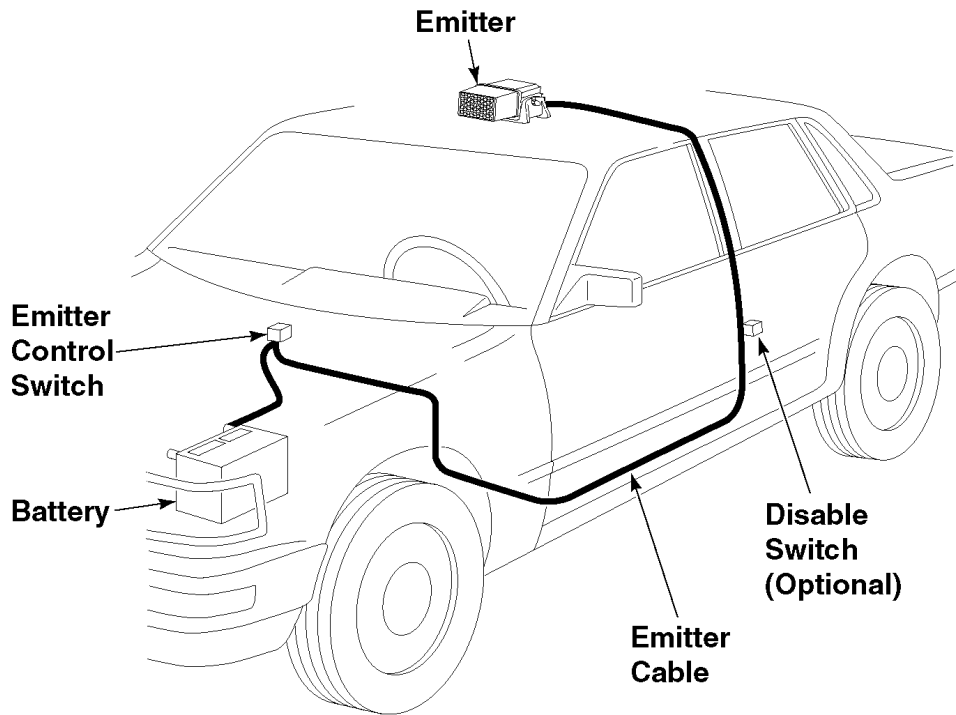

Opticom-309A

Figure 3-1. Typical Vehicle Equipment Installation for Priority Vehicle

4. Features

3M™ Opticom™ GPS Priority Control System Vehicle Equipment have the following features:

- Impact resistant design
- Vehicle identification encoding; selectable at installation
- User-selectable disable mode; Latching or Non-Latching modes
- Diagnostic indicators
- 400,000 vehicle identification codes
- Wide operational temperature range:
–30° F to +140° F
- Meets FCC part 15 Class A specifications
- 15-foot cable for installation flexibility
- J1708 compliant communication port
- Available Windows™¹ Configuration and Maintenance Software

¹ Windows is a trademark of Microsoft Corporation.

5. Installation

This section describes the installation of the vehicle equipment.

Please read and fully understand the following precautionary paragraphs before starting the installation.

- Before cutting or drilling any openings in the vehicle or lightbar, draw a diagram showing placement, measurements, and dimensions. Use the diagram to avoid drilling or cutting holes in undesirable locations.
- Always follow the vehicle manufacturer's recommendations concerning modification, alteration, and installation or connection of accessories or equipment to the vehicle and lightbar.
- Installation on specialty vehicles (such as motorcycles, parking enforcement, utility, and special maintenance vehicles) requires particular care and attention to details.
- Do not mount the vehicle equipment within 18 inches of a radio antenna.
- Follow the installation instructions to avoid possible radio frequency interference problems.
- The Radio/GPS module should be oriented to have the highest point facing forward on the vehicle. If necessary, one of the two sides may face forward. The end with the wire entry point should never point forward. It should be mounted level and as high on the vehicle as possible.
- The Radio/GPS module must not be obstructed by lights, speakers, antennas, or other devices.
- The Radio/GPS module should not be mounted inside the passenger compartment.
- The Radio/GPS module should have an unobstructed view of at least 50% of the sky.
- Wires that are routed under carpets or mats should be run between the pad and the carpet. This will minimize abrasion and heat damage from catalytic converters.
- Protect cables with armor or sheathing when they are routed around sharp corners and edges. Avoid routing cables through potential pinch points. Clamp or tie all cables in place. Route and secure cables well away from moving parts.
- Do not disassemble the Radio/GPS module. There are no user serviceable parts inside.
- Do not modify the Radio/GPS module.



CAUTION

Modifying the Radio/GPS module may seriously damage the equipment and void the warranty. **Do not attempt to disassemble or modify the Radio/GPS module in anyway.** Modifying the radio and/or antenna in anyway may cause the radio to violate FCC requirements.

5.1 Radio/GPS Module Installation

This subsection describes how to install the 3M™ Opticom™ GPS Priority Control System Radio/GPS Module.

WARNING

Vehicle batteries contain sulfuric acid and may contain explosive gases. **Keep sparks, flames, and cigarettes away. Wear eye protection. Disconnect the negative cable first to prevent shorting the positive terminal to the chassis when removing the positive cable.** Battery acid may cause skin irritation and eye injury. Explosive gases may cause severe injury or death.

1. Disconnect the battery before beginning the installation. Disconnect the negative battery cable first, then the positive battery cable.
2. Remove interior panels and headliners, as necessary, to provide access for cable routing.
3. Using the Radio/GPS module as a template, mark where you want to drill holes at the mounting location.
4. Drill three 1/2-inch holes at the mounting location.

NOTE: The installer may have to fabricate special brackets to mount the Radio/GPS module on some vehicles.
5. Place the three rubber Wellnuts into the holes.
6. Position the module over the Wellnuts and use three 1/4-20 x 1/2 inch screws to secure the module to the vehicle. Use removable loctite to prevent the screws from loosening.
7. Mark the location of the entry hole for the Radio/GPS module cable. Check the hole location both inside and outside of the vehicle.
8. Drill a 1/2-inch hole for the vehicle equipment cable entrance grommet.
9. Tape wrap the end of the vehicle equipment cable to protect the wires and to ease cable routing.
10. Select an appropriate size grommet from those supplied. The grommets are supplied in three sizes to allow for different thicknesses of vehicle sheet metal.
11. Place the grommet on the cable and slide it toward the module. Leave enough cable exposed to reach the module.
12. Route the taped end of the cable from the module mounting location to the control switch module location.
13. Apply lubricant to the grommet, then insert it into the hole in the vehicle body or lightbar. (Window cleaner works well as a lubricant.)
14. Remove the wire entry cover from the Radio/GPS module.
15. Disassemble the cable grommet and route the cable through the plastic sleeve and the rubber plug. Leave approximately 5 inches of cable inside the cover and tighten the plastic sleeve to secure the cable.
16. Strip approximately 3 inches of the outer jacket. Be careful not to cut the wires inside.
17. Strip 1/4 inch of insulation from each wire.

NOTE: It is very important to not strip too much insulation, which may lead to short circuits; or too little insulation, which may prevent the wire from making adequate contact.
18. Place each wire into the appropriate hole in the terminal block and tighten the screw to secure the wire. There is a label on the terminal block corresponding to the color code for each wire. The terminal block may be removed from the module to allow easier connections.
19. Reattach the wire entry cover to the module and tighten the screws. Push any excess cable back inside of the vehicle. Allow some extra cable for strain relief.
20. Dry the grommet and apply a sealant to the cable, grommet, and vehicle to seal the assembly against moisture penetration. (Silicone RTV is a good choice for a sealant.)
21. Finish routing and securing the cable in the vehicle. Use cable ties to secure all wires away from heat sources and moving parts.
22. Remove the tape from the end of the vehicle equipment cable.

5.2 Control Switch Module Installation

This subsection describes the installation of the control switch module. It also describes how to connect the vehicle equipment cable from the Radio/GPS module to the control switch module.

Please read and fully understand the following precautionary paragraphs before installing the vehicle equipment control switch module.

- Installations may include a customer-supplied disable switch in addition to the control switch module. The Disable feature turns off radio transmission when the disable switch closes to battery negative or positive. This feature typically uses an existing switch that indicates the presence of conditions deemed appropriate to disable radio transmission. Such conditions include putting the transmission in park, setting the parking brake, or opening the vehicle operator's door.
 - The control switch module location must be readily accessible and visible to the vehicle operator.
 - The control switch module must not be in the path of airbag deployment.
 - The cable is routed between the Radio/GPS module, the control switch module, the disable switch, the vehicle turn signals, the light bar switch, and the battery.
 - Use care when drilling holes to avoid drilling into undesirable locations.
1. Determine the desired location to mount the vehicle equipment control switch module. Mark and drill two 7/32-inch holes, using the vehicle equipment control switch mounting bracket as a template.
 2. Insert the two 10-32 x 3/4-inch cap screws through the holes in the mounting bracket and mounting surface. See Figure 5-1.
 3. Use the two lock washers and 10-32 nuts to secure the bracket to the vehicle.

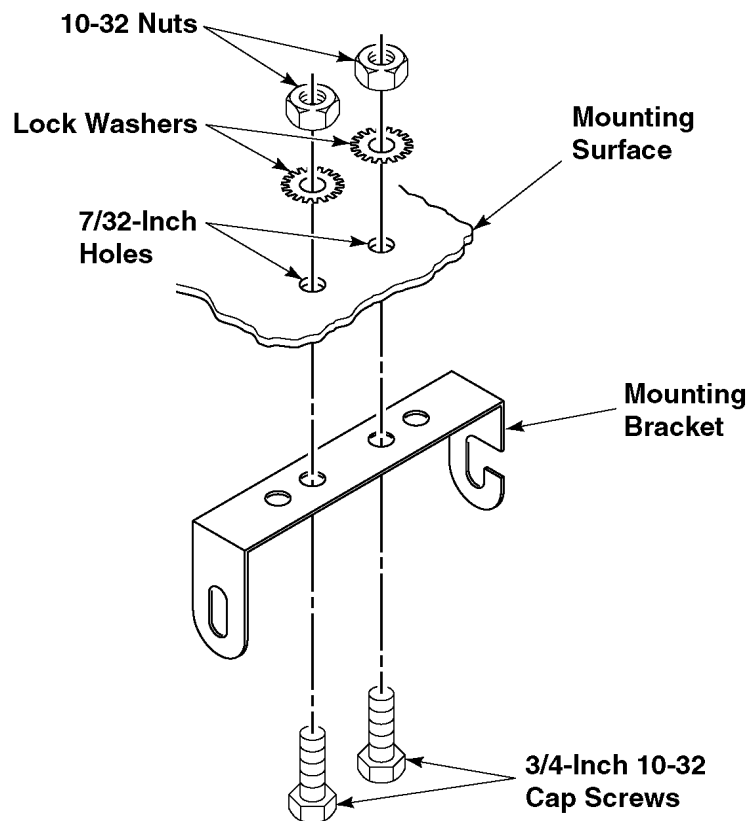

Opticom-06A

Figure 5-1. Control Switch Module Mounting Bracket Installation

4. Cut the 3M™ Opticom™ GPS Priority Control System cable to the proper length.
5. Remove about 3 inches of the outer jacket from the end of the cable. Be careful not to cut the wires inside.
6. Strip 1/4 inch of insulation from each wire.

NOTE: It is very important not to strip too much insulation, which may lead to short circuits; or too little insulation, which may prevent the wire from making adequate contact.

7. Place each wire into the appropriate hole in the terminal block and tighten the screw to secure the wire. There is a label on the terminal block corresponding to the color code for each wire. The terminal block may be removed from the module to allow easier connections.
8. Place the control switch module into the mounting bracket. Use the two 1/4-inch acorn nuts and lock washers to secure the control switch module to the bracket.

5.3 Final Vehicle Wiring

1. Plug the Vehicle Interface Harness into the 15-pin connector on the back of the control switch module.
2. Route each of the wires to the appropriate positions for termination. See the table below for wire identification.

Wire Color	Signal
TBD	+12 VDC
TBD	Ground
TBD	Left Turn Signal input
TBD	Right Turn Signal input
TBD	Remote Activation
TBD	Disable input

3. Connect the TBD wire to a 12 VDC power source that provides at least x amps at all times. In order for the GPS receiver to maintain an accurate location, it is necessary to provide 12 VDC to the receiver at all times. Therefore, it is necessary to connect to a constant 12 VDC source.

3M recommends that a direct connection to the battery be used. If this is not possible, use a terminal block with a direct connection to the battery. Install the provided x amp fuse and fuse holder. Attach the provided fuse size label.

4. Connect the TBD wire to vehicle chassis ground (DC-). Again, it is recommended that this connection be made directly to the battery or to a terminal block with a direct connection to the battery.
5. Connect the TBD wire to a switch that will actuate when the driver reaches the scene and steps out of the vehicle. This could be a door switch, gear select switch, etc. The switch may provide either +12 VDC or a ground.
6. In order for the vehicle equipment to transmit turn signal information to the intersection equipment, it is necessary to interface the vehicle equipment to the vehicle turn signal indicators. This is done by connecting the TBD & TBD wires to the vehicle turn signal wires.
7. Connect the TBD wire to a point that allows remote activation of the vehicle equipment. A point that provides +12 VDC is required. A switch that activates the light bar is the most common point to make this connection.

5.4 Performance Tests

 **WARNING**

A completed installation that is not tested may result in improper system operation, which may result in accidents and/or injuries. **To avoid this problem, test the system to verify proper operation.** Improper system operation may result in unsafe driver action.

These installation instructions are the result of tests performed in our laboratory and we believe these tests to be accurate and complete. However, each installation involves variables that cannot be controlled or predicted. These variables may affect the operational characteristics of the system.

To ensure proper system operation, 3M strongly recommends that, when the system is turned on, the installer functionally tests the system using an Opticom GPS-equipped vehicle and an Opticom GPS-equipped intersection.

To test the system, the installer drives the priority vehicle through the intersection to verify that the system is performing in accordance with customer requirements.

6. Maintenance

3M™ Opticom™ GPS Priority Control System components are designed for reliable operation. Inspect the components at regular intervals to ensure proper system operation.

3M recommends the following:

- Each intersection system and vehicle system should be inspected and tested at least every 12 months to ensure it functions to your specifications and requirements.
- Intersection systems should be tested with known good vehicle systems.
- Vehicle systems should be tested with known good intersection systems.
- You should develop a test plan that fits your department's operations and meets the needs of your system.
- You should keep accurate and up-to-date records of system performance and test results.

Important Notice to the Purchaser

THE FOLLOWING IS MADE IN LIEU OF ALL WARRANTIES OR CONDITIONS, EXPRESS OR IMPLIED, INCLUDING THE IMPLIED WARRANTY OR CONDITION OF MERCHANTABILITY OR FITNESS FOR A PARTICULAR PURPOSE. THE REMEDIES SET FORTH HEREIN ARE EXCLUSIVE.

3M will repair or replace any Opticom Priority Control System component found not to meet 3M's specifications within five (5) years from the date of shipment from 3M. See "Summary of Warranty/Maintenance Coverage" for details and limitations of the coverage plan. This warranty shall not apply to incandescent lamps (confirmation lights) or to any system component which has been (1) repaired or modified by persons not authorized by 3M; (2) subjected to misuse, neglect or accident; or (3) has been damaged by extreme atmospheric or weather-related conditions.

IN NO EVENT SHALL 3M BE LIABLE IN CONTRACT OR IN TORT FOR ANY INJURY, LOSS, OR DAMAGE, WHETHER NON-SPECIFIED DIRECT, INDIRECT, INCIDENTAL, SPECIAL OR CONSEQUENTIAL, ARISING OUT OF THE USE OR INABILITY TO USE THE OPTICOM SYSTEM OR ANY COMPONENT THEREOF, REGARDLESS OF THE LEGAL THEORY ASSERTED.

3M has designed, developed and tested each Opticom priority control system component as part of a matched component system. 3M makes no warranty whatsoever concerning the reliability or safety of Opticom system components when used with non-Opticom system products. 3M shall not be responsible for any Opticom component which 3M determines has been damaged in whole or in part by its use with a non-Opticom system product.

Sale and use of the Opticom priority control system is expressly restricted to authorized agencies of government customers, within their respective jurisdictions. However, because the infrared signal generated by the Opticom system is not exclusive, 3M cannot ensure exclusive activation by the purchaser. Authorized users who desire to use or coordinate use of the Opticom system with that of other jurisdictions must first obtain the prior written approval of each authorized user in the jurisdiction where use is sought.



**Intelligent Transportation Systems
3M Traffic Control Materials Division**

3M Center, Bldg. 225-5S-08
St. Paul, Minnesota 55144-1000
Customer Service 1-800-553-1380
Technical Service 1-800-258-4610
Worldwide Technical Service 1-651-575-5072
Website www.3M.com/its

3M Canada Company

P.O. Box 5757
London, Ontario, Canada
N6A 4T1
519-451-2500
1-800-3MHELPS

Printed in U.S.A.
Copyright © 2002, 3M IPC
All rights reserved.
75-xxxx-xxxx-xx