

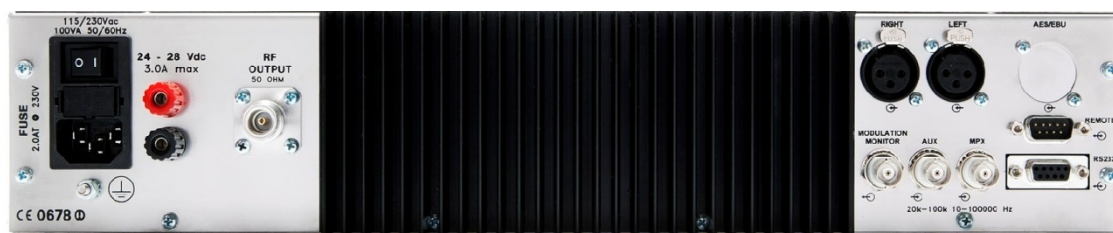

Marti GTX / GRX BROADCAST STL

USER AND MAINTENANCE MANUAL



GTX / GRX STL TRANSMITTER & RECIEVER

Technical Manual

©2021 Broadcast Electronics all rights reserved.

The information in this publication is subject to improvement and change without notice. Although every effort is made to ensure the accuracy of the information in this manual, Broadcast Electronics accepts no responsibility for any errors or omissions. Broadcast Electronics reserves the right to modify and improve the design and specifications of the equipment in this manual without notice. Any modifications shall not adversely affect performance of the equipment so modified.

Proprietary Notice

This document contains proprietary data of Broadcast Electronics. No part of this publication may be reproduced, transmitted, transcribed, stored in a retrieval system, translated into any other language in any form or by any means, electronic or mechanical, including photocopying or recording, for any purpose, without the express written permission of Broadcast Electronics.

Trademarks

Broadcast Electronics and the BE logo are registered trademarks of Broadcast Electronics.

Marti Electronics and the Marti logo are registered trademarks of Broadcast Electronics.

All other trademarks are property of their respective owners.

Copyright

Copyright laws protect artwork depicting circuitry in this manual.

Information in this manual is subject to change without notice and does not represent a commitment on the part of Broadcast Electronics.

Broadcast Electronics may make improvements and/or changes in this manual or in the product described herein at any time.

Broadcast Electronics Product Warranty (One-Year Limited)

Broadcast Electronics hereby warrants the Marti GTX & GRX products manufactured by Broadcast Electronics against any defects in material or workmanship at the time of delivery thereof, or that develop under normal use within a period of one (1) year from the date of shipment.

Broadcast Electronics reserves the right to repair equipment under warranty with new or refurbished equipment or parts. Broadcast Electronics' sole responsibility, with respect to any equipment or parts not conforming to this warranty, is to replace or repair such equipment upon the return thereof F.O.B. to Broadcast Electronics' factory in Quincy, Illinois, U.S.A. In the event of replacement pursuant to the foregoing warranty, only the unexpired portion of the warranty from the time of the original purchase will remain in effect for any such replacement.

This warranty shall exclude the following products, component parts and/or assemblies:

- (a) Transmitter power output tubes shall only carry the original manufacturers' or suppliers' standard warranty in effect on their original shipment date.



- (b) All computers, computer peripherals, cables, hard disk drives, etc., shall only carry the manufacturers' or suppliers' standard warranty in effect on their original shipment date.
- (c) "Components", defined as separate and individual parts (e.g. transistors, integrated circuits, capacitors, resistors, inductors, fans, etc.), resold by Broadcast Electronics from another manufacturer or supplier, shall only carry a 90-day warranty, effective the date of shipment. Any such "Components" being returned for warranty claim must be (1) returned in their original packaging and (2) must be in new, unused condition. Broadcast Electronics is unable to process or resolve component defects or performance concerns on components that have been soldered, installed, wired or in any way altered from their new condition.
- (d) "Resale Equipment", defined as equipment purchased from another manufacturer or supplier, then resold by Broadcast Electronics, shall only carry such manufacturer's or suppliers' standard warranty in effect as of the original shipment date. All warranty claims against any and all "resale equipment" sold by Broadcast Electronics must be filed directly with the original equipment manufacturer. Broadcast Electronics is unable to process or resolve equipment defects or performance concerns on products or services not manufactured by Broadcast Electronics.

This warranty shall not extend to claims resulting from any acts of God, terrorism, war, defects or failures caused by Purchaser or user abuse or misuse, operator error, or unauthorized attempts to repair or alter the equipment in any way.

Under no circumstances shall Broadcast Electronics be responsible for indirect, incidental or consequential damages, including, but not limited to transportation costs, non-authorized repair or service costs, downtime costs, costs for substituting equipment or loss of anticipated profits or revenue incurred by Purchaser, whether based in contract, tort or for negligence or breach of statutory duty or otherwise. The terms of the foregoing warranty shall be null and void if the equipment has been altered or repaired without specific written authorization from Broadcast Electronics, or if not installed according to Broadcast Electronics' instruction manuals, including, but not limited to, the absence of proper grounding, surge (TVSS) protection on the AC circuit panel or proper lightning protection/grounding on all output circuits, or if equipment is operated under environmental conditions or circumstances other than those specifically described in Broadcast Electronics' product literature or instruction manual which accompany the equipment. **The warranty shall be voided if the product or subassembly is equipped with a tamper seal and that tamper seal is broken.** Broadcast Electronics shall not be liable for any expense of any nature whatsoever incurred this warranty. If the equipment is described as "used" equipment, it is sold as is and where is and no warranty applies unless authorized in writing.

EXCEPT AS SET FORTH HEREIN, AS TO TITLE AND AS SPECIFICALLY REQUIRED BY LAW, THERE ARE NO OTHER WARRANTIES, OR ANY AFFIRMATIONS OF FACT OR PROMISES BY BROADCAST ELECTRONICS, WITH REFERENCE TO THE EQUIPMENT, OR TO MERCHANTABILITY, FITNESS FOR A PARTICULAR APPLICATION, SIGNAL COVERAGE, INFRINGEMENT, OR OTHERWISE, WHICH EXTEND BEYOND THE DESCRIPTION OF THE EQUIPMENT ON THE FACE HEREOF.



IMPORTANT INFORMATION

EQUIPMENT LOST OR DAMAGED IN TRANSIT

When delivering the equipment to you, the truck driver or carriers' agent will present a receipt for your signature. Do not sign it until you have:

1) Inspected the containers for visible signs of damage and 2) Counted the containers and compared with the amount shown on the shipping papers. If a shortage or evidence of damage is noted, insist that notation to that effect be made on the shipping papers before you sign them.

Further, after receiving the equipment, unpack it and inspect thoroughly for concealed damage. If concealed damage is discovered, immediately notify the carrier, confirming the notification in writing, and secure an inspection report. This item should be unpacked and inspected for damage WITHIN 15 DAYS after receipt. Claims for loss or damage will not be honored without proper notification of inspection by the carrier.

RF PRODUCT TECHNICAL ASSISTANCE, REPAIR SERVICE, & PARTS

Technical assistance is available from Broadcast Electronics by letter, prepaid telephone or E-mail. Do not return any merchandise without first contacting Broadcast Electronics and receiving prior written approval and a Return Authorization. We will provide special shipping instructions and a code number that will assure proper handling and prompt issuance of credit. Please furnish complete details as to the circumstances and reasons when requesting return of merchandise. Equipment requiring repair or overhaul should be sent by common carrier, prepaid, insured, and well protected. If proper shipping materials are not available, contact the RF Technical Services department for a shipping container. We can assume no liability for inbound damage, and necessary repairs become the obligation of the shipper. All returned merchandise must be sent freight prepaid and properly insured by the customer

Emergency and warranty replacement parts may be ordered from the following address. Be sure to include the equipment model number, serial number, part description, and part number. Non-emergency replacement parts may be ordered directly from the Broadcast Electronics stock room (see next page.)

RF TECHNICAL SERVICES

Telephone: +1 (217) 224-9617
E-Mail: rfservice@bdcast.com
Fax: +1 (217) 481-7018

FACILITY CONTACTS

Broadcast Electronics, - Quincy Facility
4100 N. 24th St. P.O. BOX 3606
Quincy, Illinois 62305
Telephone: +1 (217) 224-9600
Fax: +1 (217) 481-7108
General E-Mail: bdcast@bdcast.com
Web Site: www.bdcast.com

PARTS



Telephone: +1 (217) 224-9617

E-Mail: parts@bdcast.com

RETURN, REPAIR, AND EXCHANGES

Do not return any merchandise without our written approval and Return Authorization. We will provide special shipping instructions and a code number that will assure proper handling and prompt issuance of credit. Please furnish complete details as to circumstances and reasons when requesting return of merchandise. All returned merchandise must be sent freight prepaid and properly insured by the customer.

MODIFICATIONS

Broadcast Electronics, reserves the right to modify the design and specifications of the equipment in this manual without notice. Any modifications shall not adversely affect performance of the equipment so modified.



SAFETY PRECAUTIONS

PLEASE READ AND OBSERVE ALL SAFETY PRECAUTIONS

DANGEROUS HAZARDS EXIST IN THE OPERATION OF POWER TRANSISTORS

The operation of power transistors involves one or more of the following hazards, any one of which, in the absence of safe operating practices and precautions, could result in serious harm to personnel.

A. HIGH VOLTAGES & CURRENTS – AC mains voltages can be deadly. DC power supplies and;/or batteries used in RF amplifier circuits can supply very high currents.

B. HOT SURFACES – Certain areas of the equipment, heat sinks and components may be operating well above ambient temperature. In particular are the junction temperatures of power transistors which can reach temperatures of several hundred degrees centigrade and cause serious burns if touched

C. RF BURNS - RF power transistors and their circuits may contain high RF potentials. Do not operate an RF power module with the covers removed.

RADIO FREQUENCY RADIATION

Exposure of personnel to RF radiation should be minimized, Personnel should not be permitted in the vicinity of open energized RF generating circuits, or RF transmission systems (waveguides, cables, connectors, etc.), or energized antennas. It is generally accepted that exposure to “high levels” of radiation can result in severe bodily injury including blindness. Cardiac pacemakers may be affected.

The effect of prolonged exposure to “low level” RF radiation continues to be a subject of investigation and controversy. It is generally agreed that prolonged exposure of personnel to RF radiation should be limited to an absolute minimum. It is also generally agreed that exposure should be reduced in working areas where personnel heat load is above normal. A 10 mW/cm² per one tenth hour average



level has been adopted by several U.S. government agencies including the Occupational Safety and Health Administration (OSHA) as the standard protection guide for employee work environments. An even stricter standard is recommended by the American National Standards Institute which recommends a 1.0 mW/cm^2 per one tenth hour average level exposure between 30 Hz and 300 MHz as the standard employee protection guide (ANSI C95.1-1982).

RF energy must be contained properly by shielding and transmission lines. All input and output RF connections, such as cables, flanges and gaskets must be RF leak proof. Never operate a power tube without a properly matched RF energy absorbing load attached. Never look into or expose any part of the body to an antenna or open RF generating tube or circuit or RF transmission system while energized. Monitor the tube and RF system for RF radiation leakage at regular intervals and after servicing.

**IC RSS-GEN, Sec 8.3 Warning Statement-
(Required for Transmitters w/ detachable antennas)**

ENGLISH:

This radio transmitter 131A-GTX900 has been approved by Industry Canada to operate with the antenna types listed below with the maximum permissible gain and required antenna impedance for each antenna type indicated. Antenna types not included in this list, having a gain greater than the maximum gain indicated for that type, are strictly prohibited for use with this device.

FRENCH:

Le présent émetteur radio 131A-GTX900 a été approuvé par Industrie Canada pour fonctionner avec les types d'antenne énumérés ci-dessous et ayant un gain admissible maximal et l'impédance requise pour chaque type d'antenne. Les types d'antenne non inclus dans cette liste, ou dont le gain est supérieur au gain maximal indiqué, sont strictement interdits pour l'exploitation de l'émetteur.

Note: RF EXPOSURE SAFETY DISTANCE

RF Exposure Limits for Canada, according to IC regulation: setting to the maximum of the output power of the apparatus, to guarantee the limits of exposure declared within this document, it is necessary that the antenna gain used with this device should be 0dBi or less and all persons should maintain a minimum separation distance of 0.4736 m (47.36 cm) for general uncontrolled exposure and general controlled exposure.

For FCC standards, a safety distance of 0.4736 m (47.36 cm) is declared.

Limites d'exposition RF: en réglant au maximum de la puissance de sortie de l'appareil, afin de garantir les limites d'exposition déclarées dans ce document, il est nécessaire que le gain d'antenne utilisé avec cet appareil doit être de 0 dBi ou moins et toutes les personnes doivent conserver une distance de séparation minimale de 47.36 cm pour les expositions générales non contrôlées et les expositions générales contrôlées.

Table of Contents

1	OVERVIEW Marti GTX / GRX	9
1.1	General Description	9
1.2	Transmitter Review	11
1.3	Receiver Review	13
2	TECHNICAL SPECIFICATIOINS	15
2.1	GTX and GRX Overall Data.....	15
2.2	GTX Transmitter Only	16
2.3	GRX Receiver Only	17
3	INSTALLATION	19
3.1	Rack Mounting and Cooling.....	19
3.2	Control Functions.....	19
3.3	GTX Parallel Remote.....	19
3.4	GRX Parallel Remote.....	20
3.5	Battery or DC Supply	20
3.5.1	Notes on battery and wiring	20
4	SET UP	23
4.1	Password Organization	23
4.2	Factory Default Passwords	23
4.3	Display Menus and Navigation.....	23
4.3.1	START & DEFAULT FIELDS.....	24
	• Timeouts and Default Fields	24
	• Field INIT: Initialization Display	25
	• Field #00: Escape / Default Display.....	25
	• Field #01: Operation / Setup Selection	25
	• Field #20: Enter Password.....	25
4.3.2	TRANSMITTER FIELDS & MENU TREE.....	26
	• OPERATION MENUS	27
	• Field #02: Direct & Reflected Power	27
	• Field #04: Multiplex Signal Level (Output Modulation)	27
	• Field #05: Left & Right Signal Level in dB.....	27
	• Field #06: L & R Signal Level / Analog Meter	27
	• Field #07: RDS / SCA Auxiliary Modulation Level.....	28
	• Field #09: Internal Voltages	28
	• Field #10: Temperature, Data and Clock.....	28
	• SETUP MENUS.....	29
	• Field #21: Local/Remote control setup	29
	• Field #22: Transmission Frequency setup	29
	• Field #23: Output Power setup.....	29
	• Field #24: LF Modulation Input Level setup.....	29
	• Field #25: Auxiliary Input Level setup	30
	• Field #26: Limiter setup.....	30
	• Field #27: Transmission Mode, and Pre-emphasis Setup.....	31
	• Field #28: Reference Deviation setup.....	31
	• Field #29: Display Contrast setup	31
	• Field #30: Time & Date setup	31
	• Field #31: Elapsed Time	31
	• Field #32: Password Management.....	32
	• Field #33: Alarm Setup and Display	33
	• Field #34: I/O Pin Allocation and Logic Level setup	33



•	Field #35: Synthesis setup	34
•	Field #37: Ethernet & Lan setup	34
4.3.3	RECEIVER FIELDS & MENU TREE	35
•	OPERATION MENUS	36
•	Field #02: Receiver Frequency	36
•	Field #03: Received RF Field and Muting.....	36
•	Field #04: MPX Modulation and Reception Field	36
•	Field #04: Modulation of the Multiplex Signal	36
•	Fields #05 & #06: L and R Decoded Output Levels.....	36
•	Field #08: Stereo Pilot Frequency level	37
•	SETUP MENUS	37
•	Field #22: Frequency setup.....	37
•	Field #24: LF Output Level setup.....	37
•	Field #25: Receiver Muting setup.....	37
•	Field #26: De-emphasis setup	38
•	Field #28: Optional Boards Detection.....	38
•	Field #33: Alarm setup and display	39
•	Field #34: I/O pin allocation and logic level setup	39
•	Field #36 Left & Right Level.....	40
•	Field #37 Headphone Volume	40
•	Field #39 Serial Number	40
5	SERVICE & CHASSIS DIAGRAMS.....	41
5.1	Transmitter Drawings.....	42
5.1.1	GTX Mechanical Layout – VHF & UHF Models	42
5.2	Receiver Drawings.....	43
5.2.1	GRX Mechanical Layout – VHF & UHF Models	43



Figures

Figure 1 – GTX Transmitter Block Diagram.....	11
Figure 2 – GTX Transmitter Rear Panel.....	12
Figure 3 – GRX Rear Panel	14
Figure 4 - GTX & GRX Remote Connectors	19
Figure 5 – Transmitter Menu Tree.....	26
Figure 6 - Receiver Menu Tree.....	35
Figure 7 – Transmitter Mechanical - VHF & UHF Models.....	42
Figure 11 – Receiver Layout - VHF & UHF.....	43

Tables

Table 1 – Battery Life	22
------------------------------	----



1 OVERVIEW

Marti GTX / GRX

BROADCAST STL FAMILY SERIES

VHF / UHF & SHF Bands

1.1 General Description

The Marti GTX/GRX series STLs are the result of experience gained by Broadcast Electronics during years of producing FM broadcast equipment, transmitters, STL and stereo encoders.

These radio links were specifically designed to comply with the latest international standards and the requirements of advanced broadcasters, meeting tighter specifications than usually required, at an affordable cost.

Great care was spent into producing a Hi-Fi-quality modulated signal, with low residual noise and distortion. The RF signal is also free from spurious and harmonic components to a higher degree than required by USA, CCIR, European, and most other national standards.

To obtain this outstanding performance, Broadcast Electronics strongly recommend relying on qualified personnel to install and verify the equipment which makes up the radio station, i.e. the STL, the transmitters and the power amplifiers, the corresponding antennas, cables and connectors. This will assure to achieve the best performance and stability in time.

To this aim, Broadcast Electronics especially recommend that their equipment should not be tampered with by unskilled personnel and its after-sale service is available to customers for any technical problem. Before proceeding to installation, please carefully read at least the general installation part of this manual, to gain confidence with the equipment.

This equipment is very stable and changes to the internal pre-setting other than frequency and few other options are not usually required, however if they are, once again they must be done by skilled personnel, with proper instrumentation and service documentation. Improperly tampering with the settings may harm the apparatus or jeopardize the guaranteed performance.

THIS EQUIPMENT COMPLIES WITH ALL RELEVANT EMI/EMC AND SAFETY REQUIREMENTS, ETSI EN300454-1/2 AND ETS301489-01/11 STANDARDS.

NO INTERNAL ADJUSTMENT OR PRESETTING IS REQUIRED DURING NORMAL OPERATIONS. THE APPARATUS SHALL BE PROPERLY EARTHED AND OPERATED WITH ALL COVERS CLOSED WITH ALL FASTENERS TO PREVENT ELECTRICAL HAZARDS AND COMPLY WITH THE EMI & EMC STANDARDS.

The Marti GTX transmitter and its companion Marti GRX receiver are the core of a high quality, synthesized studio-to-transmitter link (STL), to be used for broadcast repeaters in conjunction with any standard FM or AM transmitter. They're an evolution of the established Marti GTX/GRX series STL whose main circuitry is still extensively used here with a new controller, user interface and software and more advanced oscillators in a compatible 2RU, 19" case.

They allow the reception of mono or stereo signal and its retransmission without using any additional stereo-coder on the receiving end: in both cases the LF output signal from the receiver must be sent to the stereo input (linear or not pre-emphasized) of the local FM rebroadcast transmitter.

The STL is built for several different frequency slots from VHF to the SHF range. Two main models are built: one for the 200 - 960 MHz and the other frequencies in the SHF band. While the, controls, basic circuitry and the performances are the same, some internal components vary or are specifically tuned as required to cover this wide frequency band. Usually these components are the local oscillator, the power amplifier and the input/ output filters. The factory adjusted frequency slots are 10 to 50 MHz wide and must be specified in the order. In the preset sub-range, the frequency and power of the transmitter may be freely changed on the field. The receiver may require some more adjustment for wider frequency displacement: in fact the adoption of narrow, low loss input filters permitted to achieve the best possible rejection of interfering signals in the band at the expense of some frequency agility. So nearly 8-10MHz may be used without any retouching but wider variation up to 50-60MHz will require retuning of the input filter.

Being the apparatuses are completely digitally controlled, they are extensively on field programmable by front panel or remotely in every respect. The alphanumeric display permits easy and accurate metering, adjustment and continuous monitoring of modulation levels, power, operation and internal parameters. All this information is externally available on the same RS232 I/O port that maybe used to remotely control the transmitter. In addition to the serial I/O, some signals and controls are available on a parallel I/O socket for easy interfacing with others analog controllers or supervisory systems. A powerful 3-levels password management permits a very high degree of security and privacy as may be required in different situations.

The LF input and output levels are precisely adjustable over a broad range, by means of 0.5dB stepwise variable attenuators. The transmitter has also an auxiliary input, specifically designed for RDS and SCA encoders. A modulation monitor output permits to control other transmitters or STL's with the same internally processed high-quality mpx signal. Furthermore, the system is optimized to be compatible with external digital companding encoder/decoders and to provide RDS and SCA signals, with almost no attenuation.

Optional top-quality stereo encoder/decoder boards maybe factory installed on the transmitter/ receiver or field retrofitted with minimum required technical skill. The powerful internal software and monitoring functions recognize their presence and enable the functions. A universal switch-mode power supply permits operation in the extended 95-250 VAC range with no intervention and a 24 V back-up battery input is provided too.





1.2 Transmitter Review

The transmitter and receiver set are fitted in the same sized cabinet and are nearly identical on the front view. In fact they differ for the name on the front panel and the display and for the rear panel connector's accommodation.

Both are clean and easy to control from the front panel through a single knob. The wide display and simple self-explanatory menu allows navigation through the various options. A single fast push on the jog knob acts as an "Enter" or confirmation while pushing for a longer time is interpreted as "Escape".

Some LEDs signal at a glance proper functioning and warning states. Two red led signal warning status, "Alarm" and "Limiter". A bi-stable yellow/green led signals "On the air" while a fourth one signals "PLL Lock": both these two should be green in correct operation.

An RF Monitor output connector is located on the front panel for easy test on the field

An RF Circulator, aka Isolator, is used on models in the SHF band. The Isolator is not required on the VHF/UHF bands

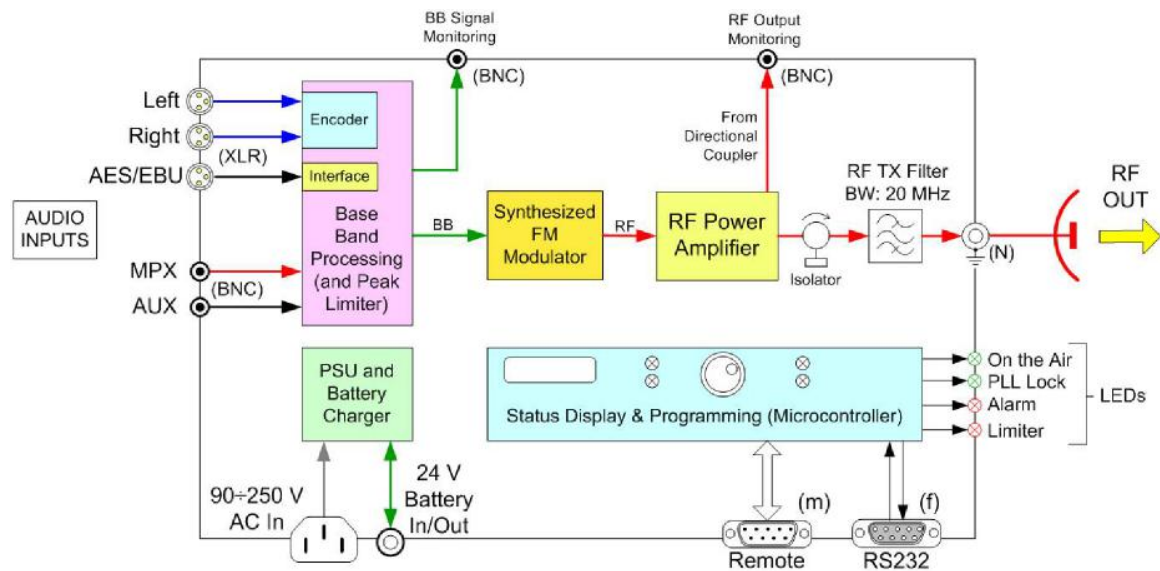

Figure 1 - GTX Transmitter Block Diagram



Figure 2 – GTX Transmitter Rear Panel

All equipment inputs and outputs but RF monitor are located on the rear panel. They are:

1. The mains supply IEC320-type outlet, which incorporates the mains On/Off switch and the fuses. The internal power supply operates in 115/230 VAC mains range without any internal or external preset or switching.
2. An additional chassis screw for system earthing and a 24V-battery backup socket pair.
3. The RF antenna connector, N-type
4. The L & R stereo analog audio channels input on balanced XLR-type connectors (L input is used only with internal Stereo Encoder option).
5. The AES/EBU stereo digital audio input on a balanced XLR-type connector which may be used as an alternative to the analog input (this is a special option and may be used only in conjunction with the internal Stereo Encoder option).
6. The wide-band external processed stereo or composite signal input on a grounded unbalanced BNC connector
7. A frequency limited (20k \bar{H} 100kHz) auxiliary channel input on a grounded, unbalanced BNC connector for a RDS or SCA signal.
8. An LF modulation output for monitoring, RDS external synchronization or re-broadcasting purpose, BNC-type
9. A RS232 Dsub9 female remote serial control port, inverted wired.
10. A parallel control port, Dsub9 male type



1.3 Receiver Review

Like the Transmitter, the Receiver front panel accommodates the single control knob, the display, four LEDs for immediate status control and a single output connector for IF monitoring.

Here too regular operation is signaled by green LEDs: "PLL Lock" and "Field". This latter is a bi-stable and lights in yellow when RF field is too low or absent. As in the Transmitter red LEDs signals improper operation. The first one, "Modulation", is activated by low or absent modulation; the last one is the general "Alarm" LED.

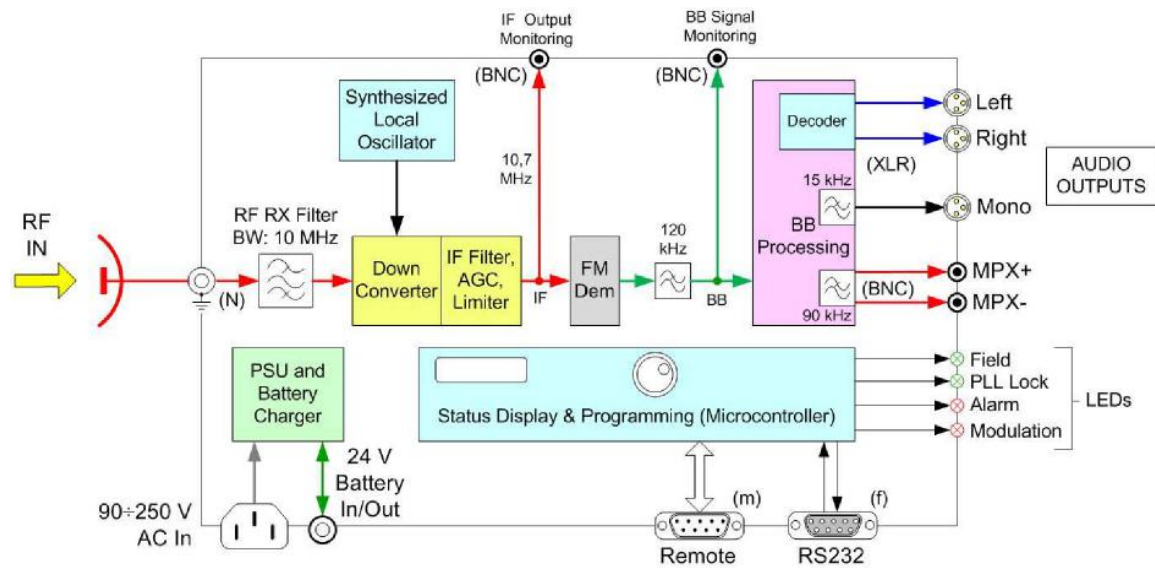

Figure 3 - GRX Block Diagram

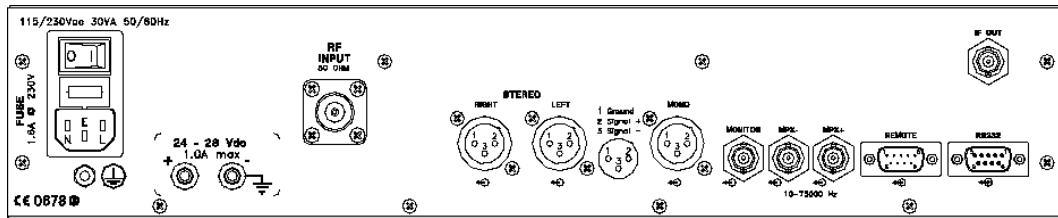

Figure 3 – GRX Rear Panel

The Receiver I/O connectors on the rear panel are:

1. The mains supply IEC320-type outlet, which incorporates the mains switch and the fuses.
2. An additional earth screw for system earthing and a 24V-battery backup socket pair.
3. The RF antenna connector, N-type
4. The main composite signal output (Mpx+, Mpx-) on two BNC-type connectors in antiphase, permitting direct drive of two separate transmitters or one in balanced mode.
5. A buffered LF monitor, BNC-type connector that maybe internally connected as an additional composite or wide-band or mono signal output.
6. The filtered/de-emphasized mono signal on a balanced male XLR-type connector.
7. The L & R audio channels output sockets on balanced XLR-type connectors only with (Internal Stereo Decoder option).
8. A RS232 Dsub9 female remote serial control port, inverted wired.
9. A parallel control port, D-Sub 9 male type

2 TECHNICAL SPECIFICATIONS

2.1 GTX and GRX Overall Data

Frequency Ranges in MHz, specified on order

Model	Standard Freq Range (MHz)	Alternate Range (MHz)
GTX/GRX200	215-270	210-260
GTX/GRX300	300-360	310-370
GTX/GRX400	400-470	N/A
GTX/GRX800	830-854	850-900
GTX/GRX900	940-960	900-940

(Other ranges on request)

Modulation: FM 75kHz peak deviation.

180kF3E mono

256kF3E stereo

Synthesis Step

10kHz (215 - 960 MHz)

25kHz (1.3 - 2.5 GHz)

Composite Output Response:

+0.1/-0.5dB 15 Hz - 67 kHz

<-6 dB @ 100 kHz

<-20 dB @ 125 kHz

Monitor Output Wideband Response:

+0.1/-1.5dB 15 Hz ÷ 100 kHz

-3 dB typ. @ 125 kHz

-6 dB typ. @ 160 kHz

Mono/Stereo Response:

±0.2dB 0 Hz ÷ 15 kHz

S/N Ratio (30÷20000Hz RMS):

>75 dB, 80 typ. Mono

>72 dB, 76 typ. Stereo

Modulation Distortion @ 100% dev**@ 1 kHz/**

Mono ≤0.10% 0.03% typical.

Stereo, 1 ch ≤0.30% 0.20% typical.

@ 30 - 7500 Hz

Mono ≤0.25% 0.12% typical.

Stereo, 1ch ≤0.30% 0.20% typical.

Stereo Crosstalk:

>50 dB 400 - 10000 Hz, typical

>40 dB 100 - 15000 Hz, typical

Input/Output:

Alarm RF/LF disable, Low RF field

Remote Control/Lock

RS232 for Monitoring and Control

Power Input Requirements:

95 / 250 VAC 50/60 Hz

22.0 - 28.0 VDC

Operating Temperature Range:

0 - 35° C recommended.

-10 - 45° C max.

2.2 GTX Transmitter Only

Frequency Error:	<2,5 ppM
Frequency Drift:	<1 ppM/year
RF Output Power:	7W / 15W (215÷960 Mhz) 2W / 5W (1.4÷2.6 Ghz)
Max Ref Pwr Allowed:	1W / 2W
RF Harmonics:	<-60 dBc
RF Spurious:	<-70 dBc, -80 dBc typ.
RF Output:	50 ohm, N connector
Audio/Input Level:	-3.5 ÷ +12.5dBm @ ± 75kHz deviation
Audio/Input:	10k ohm/600 ohm, bal./unbalanced
Common Mode Rejection:	>50 dB, >60dB typ. (20÷15000 Hz)
Audio Input Connectors:	Female XLR
Auxiliary Input Level:	-12.5 ÷ +3.5dBm @±7.5 kHz dev. -24 ÷ -8dBm @±2 kHz dev.
Auxiliary Input:	10k ohm / BNC-type
Monitor LF Output:	0 ÷ +10 dBm @ ±75kHz dev.
Pre-emphasis	0/50/75 µs ±2%
S/N, 30 Hz – 20kHz	>77 dB, 82 typ. Mono >74 dB, 77 typ. Stereo



Distortion, 30Hz – 15kHz:	<0.02% @ 75kHz dev.
Stereo Crosstalk:	>50 dB (100÷5000 Hz) >45 dB (50÷15000 Hz)
Audio Response,	
30Hz - 15 kHz:	±0.1dB
Out of Band Audio Attenuation:	>50 dB @ F≥19 kHz
Deviation Limiter:	0 - +7.1 dB, adjustable
Composite Response:	
10 Hz÷100kHz	±0.1dB
Auxiliary Response:	
10÷ 100 kHz	±0.2dB
Power Input:	50 W max @ 90/250Vac (Po= 5W) 80 W max @90/250Vac (Po=15W)
Battery Input:	≤1.8A @ 24 Vdc (Po= 5W) ≤3.0A @ 24 Vdc (Po= 15W)
Dimensions, less handles:	19" 2RU, 19.0 x 3.46 x 12.6 in 483 x 88 x 330mm

2.3 GRX Receiver Only

Receiver Noise:	≤9 dB
Image Frequency Rejection:	≥60 dB 70 typ.
Dynamic Selectivity:	>+10dB typ @ δF=300 kHz >+35dB typ @ δF=500 kHz >+45dB typ @ δF=1.0 MHz
AM Suppression:	>45 dB
Usable Input Level:	-90 ÷ -10dBm, (7μV÷70mV)
Sensitivity (typical):	Sin= -90dBm (7μV) Mono (S/N=60dB) Sin= -70dBm (70μV) Stereo
IF Monitor Output:	10.7 MHz / 0dBm
Mono or Stereo Decoded Response:	30 Hz ÷ 15 kHz ±0.1dB
Out of band Mono or Stereo Audio Response:	>50 dB @ F≥19 kHz
De-emphasis Time Constant:	0/50/75μs ±2%
S/N Ratio, (30÷20000 Hz. rms):	>72 dB, 76 typ. mono >70 dB, 73 typ. stereo

Distortion @ 1kHz / 100% dev.

- Mono $\leq 0.1\%$, 0.03% typ.
Stereo $\leq 0.3\%$, 0.20% typ.

Stereo Crosstalk: >50 dB (100÷5000 Hz)
 >45 dB (50÷15000)

Power Input: 15 W max @ 90/250Vac

Battery Input: ≤ 0.4 A @ 24 Vdc

Dimensions, less handles: 19" 2RU,
19.0 x 3.46 x 12.6 in
483 x 88 x 330 mm



3 INSTALLATION

3.1 Rack Mounting and Cooling

It is very important to install the apparatus on a stable stand/rack, in such a way to permit good ventilation to the rear heatsink

Since the STL equipment is cooled by convection in air, allow a 1RU clearance above and below the equipment. This especially important for heat sink in the rear of the transmitter

3.2 Control Functions

Both the STL Transmitter and Receiver are set and controlled by the front panel keyboard and display. The same functions can be remoted via the parallel control port and a future serial RS232 port. Both of these 2 ports are located in the right rear of the Transmitter and Receiver.

Remote Control Parallel Port

This is the primary port to accommodate control and monitoring functions on this DB9 male connector. Many of the I/O lines may be assigned to different functions and logic polarity may be changed as needed for the sites remote control equipment. Default pin assignment is listed in Section 3.2 for the Transmitter and Section 3.3 for the Receiver.

RS232 Port (Factory)

The RS232 port is a factory connection location for installing software control options. Other than this use, no connection is required to this port for installation.

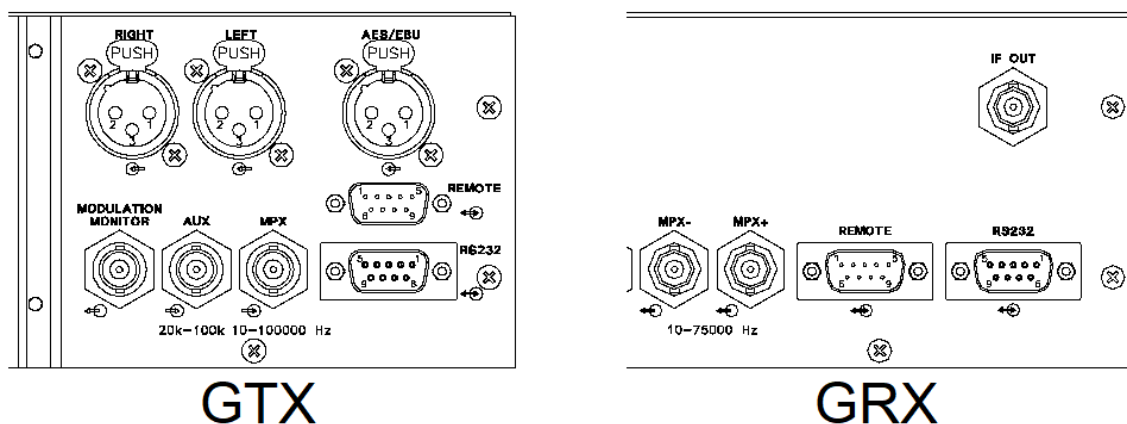

Figure 4 - GTX & GRX Remote Connectors

3.3 GTX Parallel Remote

Pins 1, 5, 8 Ground.

Pin 2, "On Air" output. Open collector transistor circuit with a resistive pull-up: at +12V 10kOhm signals that the transmitter delivers substantial RF power. It is not granted that the output power is exactly as preset.

Pin 3, Forward power output. A signal proportional to forward power, aka direct power, with a pseudo square law. Range is 0-5Vdc / 1k Ω impedance. Full power voltage ranges 3,5 to 4 V.

Pin 6, RF enable input. Base input of a common emitter transistor with a resistive pull-up. A shorted circuit to ground disables RF. Maximum voltage and current available are roughly +10V and 1mA.

Pin 7, Alarm output. Open collector transistor circuit with a resistive pull-up: logic low signal means alarm condition. Correct functioning is signaled by +12V with 10k Ω impedance. Maximum current sinking capability <10mA.

Pins 4 & 9 Reserved for future upgrades.

3.4 GRX Parallel Remote

Pins 1 & 5 Ground.

Pin 2, "Modulation OK" output. Open collector transistor circuit with a resistive pull-up: a low logic state signals modulation is present on the received signal. On the contrary, a high logic state, + 12V / 10k Ω , warns on modulation loss. As alternate function the pin may be assigned to signal "remote lock" status.

Pins 3 & 8, "Field Good". The insulated contacts of a relay are wired to these pins: the relay is default driven by the received RF. When the field exceeds the preset threshold, the relay is excited. The contacts may be chosen through an internal bridge to be "normally open (n.o.)" or "normally closed (n.c.)". Factory default is "n.o.". Alternatively, the relay may be assigned to "Alarm"

Pin 6, "LF Disable" input. Base input of a common emitter transistor with a resistive pull-up. A shorted circuit to ground disables main LF outputs. Maximum voltage and current available are nearly +10V and 1mA. Alternate function is "Remote lock": when chosen, a shorted circuit disables front panel setup functions.

-Pin 7, "Alarm" output. Open collector transistor circuit with a resistive pull-up: a logic low signal means alarm condition. Correct functioning is signaled by +12V with 10k Ω impedance. Maximum current sinking capability <10mA. This pin may be alternatively assigned to signal "Field good"

-Pins 4 & 9: Reserved for future upgrades.

3.5 Battery or DC Supply

The Marti GTX/GRX include a low voltage d.c. power supply input with battery management, to permit continuous d.c. power supply or back-up in case of mains failure. This input, whose nominal voltage is 24 V negative grounded, accepts a dc supply which may range 22 - 28 V in absence of mains supply. It delivers a regulated +27.6V to permit battery charging, when mains supply is present.

Front panel switch do not acts on d.c. supply, which is always on when applied to its terminals on the rear panel. There is no switch in series to this supply but only a diode and a self-reset fuse to protect from polarity reversal.

Voltage higher than 28Vdc applied to or current sunk from this input for different purpose than battery charging may seriously impair the equipment power supply.

3.5.1 Notes on battery and wiring

Any kind of battery may be used, provided it has the correct voltage (24 V, nominal) and an adequate capacity. Price / performance considerations may suggest plumb batteries, regular or sealed.



We suggest using sealed batteries for small systems, 20 to 40 A/hour rated. Higher capacities, like 40 ± 100 A/hour and more, may be achieved at low cost from car-type batteries: in this case always install the batteries in a well vented place, because acid gas produced during battery charging may damage the electronic equipment.

GTX and RTX battery inputs may be wired together to the same battery array, provided they both are internally set to 27.6V, as regular. In this case the power supplies appear to be in parallel (with some redundancy) and they both charge the battery array at a higher rate.

Plumb batteries are usually made up to 12 V nominal voltage, so two batteries are required in series. Wire them with proper section wire: 1 sq. mm is usually enough to connect them to the transmitter and/or the receiver; bigger sections may be used in case of long wiring.

Install batteries capable of sustaining the system for the maximum foreseen period of mains failure. Avoid to completely discharging the batteries or permanent damage may occur to them. Even if the battery manager disconnects the battery when the voltage is lower than 22V, a small test current, nearly 10-15mA is sunk by the circuitry in absence of mains power. This current is capable to deeply discharge the battery array in case of prolonged mains absence. Always remove the battery array if the system is off-line

1. Battery Life

We recommend following the literature from you battery manufacturer for correct installation and maintenance of the battery system. In absence of that literature, some common practices:

- Use batteries whose capacity is at least 2.5 - 10 times higher than the maximum expected power absorption, on prolonged mains loss.
- Never permit batteries to undergo below minimum safe voltage, on prolonged discharges.

Following these guidelines, battery life expectation may range from 2 to 5 years, depending on duty factor and temperature (low temperature decreases the capability but increases the life).

2. Back-up and recharge time

An estimate of the backup time, i.e. the capability of the batteries to power up the equipment in case of mains failure, may be done by considering that:

- The manufacturers usually specify the nominal capability of a battery, discharged in a period of 10 or 20 hour.
- For discharge faster than 10 hour, the capability will be reduced. For slower discharges, it may be increased. Typical values are 70 % for discharge in 2 hours and 110 %, for discharges in 50 hours.
- The capability will diminish with time and usage: typical derating may be 10 -30 % / year.
- Taking in count all previously said, with a real capability which is derived from the nominal one with the suggested corrections, the backup time is given by the capacity in A/hour divided the absorption of the equipment which makes up the load, in A.
- The supplied recharge current delivered by the equipment is nearly 0.5-1.0 A by the GTX and 1.5-2.0A by the RTX18, when the batteries are almost discharged.
- While the charge voltage is roughly constant, the charge current is not. The charge time may be rather long, even some day, especially in case of deep discharge and heavy load on the equipment

As a reference we give the following table with estimated maximum backup times for some combinations of equipment and batteries, which are valid only for new, fully charged batteries. The current absorption for GTX transmitter is typical for SHF version @ 5W output power or a 900MHz version @ 10W.

Higher output power will increase this absorption up to 20-30%, while lowering the output power will reduce the current absorption to roughly the same 20-30%.

Table 1 - Battery Life

	GTX	GRX	GTX + GRX	Unit of Measure
Main Consumption	1.95	0.45	2.4	Amps
Backup Time with 20A/Hour Battery	9	44	7.5	Hour(s)
Backup Time with 40A/Hour Battery	20.5	44	16.5	Hour(s)
Backup Time with 100A/Hour Battery	52	50	16.5	Hour(s)



4 SET UP

For first time users of the GTX and GRX, allow some time to become familiar on how to navigate the operation and setup menus before putting the equipment into "On Air" service.

4.1 Password Organization

As a factory default, the equipment is delivered without any access restriction. The passwords are "OFF" in both the Transmitter and Receiver. The managing of the password function is optional and we recommend its use only where needed

The password organization is set in 2 security levels, each with its own password. If password management is desired, enable both levels. The higher Level 2, permits setup access and changes while the lower Level 1 is restricted to monitoring only.

The password is 4 alphanumeric characters, including upper and lower case, plus several special symbols. The complete password is masked by dummy characters "****" until the cursor is moved to each position for selecting the character and then reverts back to a dummy character when the cursor is moved to the next position. The correct or confirmed password is never shown unless an incorrect password is entered.

The two levels are defined as follows:

Level 1: Lower security level

- If restriction is desired to prevent access to the Setup menus, then this Level can be set to "ON". With the Level 1 password enabled, the "Enter Password" field is activated when navigation to the Setup menu is attempted. Failure to insert a correct password will prevent access to Setup menu and a time-out, typically a length 3 minutes, expires to return back to Operation menu.
- Again, the factory default is set to "OFF", and any user is permitted to freely navigate through the equipment's monitoring menu information. We suggest leaving it in this state if users are expected to access most of the monitoring and control menu fields.

Level 2: Service level

- This password is used for restricting access to make changes in the Setup menu, such as frequency, RF power, audio input & output levels and other operating parameters.
- Its use is reserved to personnel who need wide access to the equipment setups and functions. After installation and the equipment checked out is completed, it is recommended to change the default factory state of "OFF" and enable the Level to ON, .
- .

4.2 Factory Default Passwords

These are the two factory default passwords:

Level 1: P001

Level 2: P002

Be sure to enable and setup the 2nd Level if passwords are going to be used in your STL system.

4.3 Display Menus and Navigation

Rotating the jog knob counterclockwise or clockwise will scroll up and down the menu displays or within a field to view the submenus when a field is entered. A quick push or tap on the knob will



function as an "Enter" or "Select" or "Confirm" command. A longer push or "Hold" of the knob will be interpreted as an "Escape" to abort the operation. Hold the knob in for 3 seconds to ensure Escape is recognized.

Refer to Figures 5 & 6, Menu Trees, and the Sample Menu below

A numbering system is used in the Menu Trees to provide a quick look up of the various display descriptions, such as the #22 circled below. In the manual, the term Field is used and it is synonymous with the terms display, screen or window, but it also represents the function and its subset of displays as required for that function

Two menu trees are diagrammed in Fig 5 & Fig 6, a Transmitter Menu Tree and Receiver Menu Tree. Both diagrams have the OPERATION on the left, and SETUP on the right of the tree, with the center displays being organized in section 4.3.1.

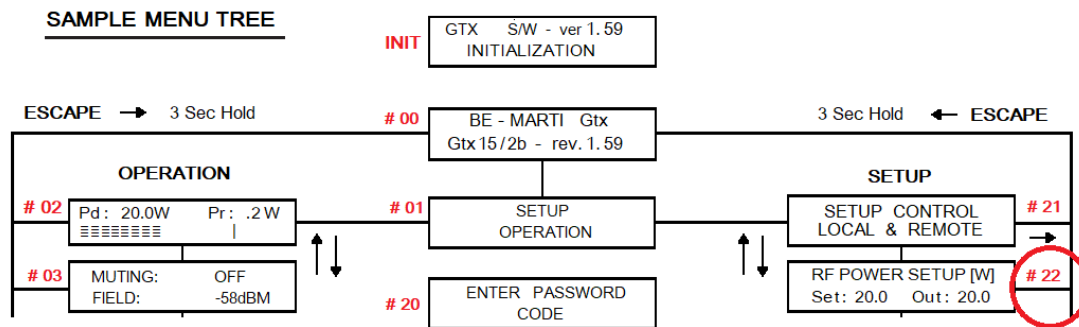

4.3.1 START & DEFAULT FIELDS

These fields are #01, #02, #00, #20, and INIT. The term Start is relative since most of these fields may be a "Starting Point" in navigation, depending on the last status of the GTX or GRX control.

- **Timeouts and Default Fields**

1. **Knob Hold 3 Seconds**...As stated above, holding the knob in for 3 seconds provides an Escape when needed and returns you to field #11.
2. **Local Input Timeout. 60 Seconds** When a Setup field is entered, and the knob is not touched or turned within 60 seconds, this timeout will activate and return back to "select a field" status in the same branch.
3. **Default Timeout 3 minutes.** If a Setup field is not selected within 3 minutes, the equipment navigates back to the Operation branch of the menu tree. It will also activate in the event a lock up occurs during data entry such as in a password entry. The navigation back to the Operation branch will typically reset on field #02. In some timeout conditions the field may be
4. **AC Restart.** An alternative to waiting for a 3 minutes timeout, is to do an AC restart. The equipment will follow the normal boot up and navigation to default field #02 in the Operation menu.

When any security level is enabled, the equipment stops access following a default timeout. The functioning of the equipment is not influenced by this state such as RF output and modulation.



- **Field INIT: Initialization Display**

This field only displays when the equipment is turned on from mains power and the field is not used in other navigation. The display is very brief, typically less than 4 seconds, before advancing to the next field after. The first line of the display illuminates in a r pixel test, and then changing to the word INITIALIZING, with the model and software release displayed in the second line. The first line will then change and display an internal option(s) if present.

STEREO ENCODER: YES
 Gtx15/2b - rev 1.59

In this example, the transmitter shows the presence (YES) or (NO) of the internal Stereo Encoder option, before advancing to Operation Field #2.

- **Field #00: Escape / Default Display**

BE - MARTI Gtx
 Gtx15/2b - rev.1.59

This is the default field that shows the equipment model, the software release and the manufacturer's name. This is the field the display returns back to when an "Escape" is keyed in.

Choosing between the Operation and Setup branch is immediately proposed after the default field is displayed. At any time, during navigation of the various fields, "escaping" will return back to the default field. However, after entering a field to change a parameter, then an escape puts you back to the last navigated field.

- **Field #01: Operation / Setup Selection**

As the title states, this field allows the Operation or Setup menu branches to be selected by pressing the one that is highlighted. . Turn the knob to highlight and select which menu branch is desired to enter. It is not possible to pass from the Operation branch directly to the Setup without passing through this field

SETUP
OPERATION

- **Field #20: Enter Password**

ENTER PASSWORD
 XXXX

This field will not be displayed if both Level 1 and Level 2 passwords are not enabled.

When passwords are enabled, the field will display when or where required and will display the Level needed for password recognition to allow further navigation or data entry. If the password is incorrect or the input is terminated by an "escape", the password states as invalid.

4.3.2 TRANSMITTER FIELDS & MENU TREE

Operation fields #02 thru #10 are described first, followed by the Setup fields. If a field number is missing or out of sequence, the number is being used in the Receiver Menu Tree to describe a different function in the menu sequence.

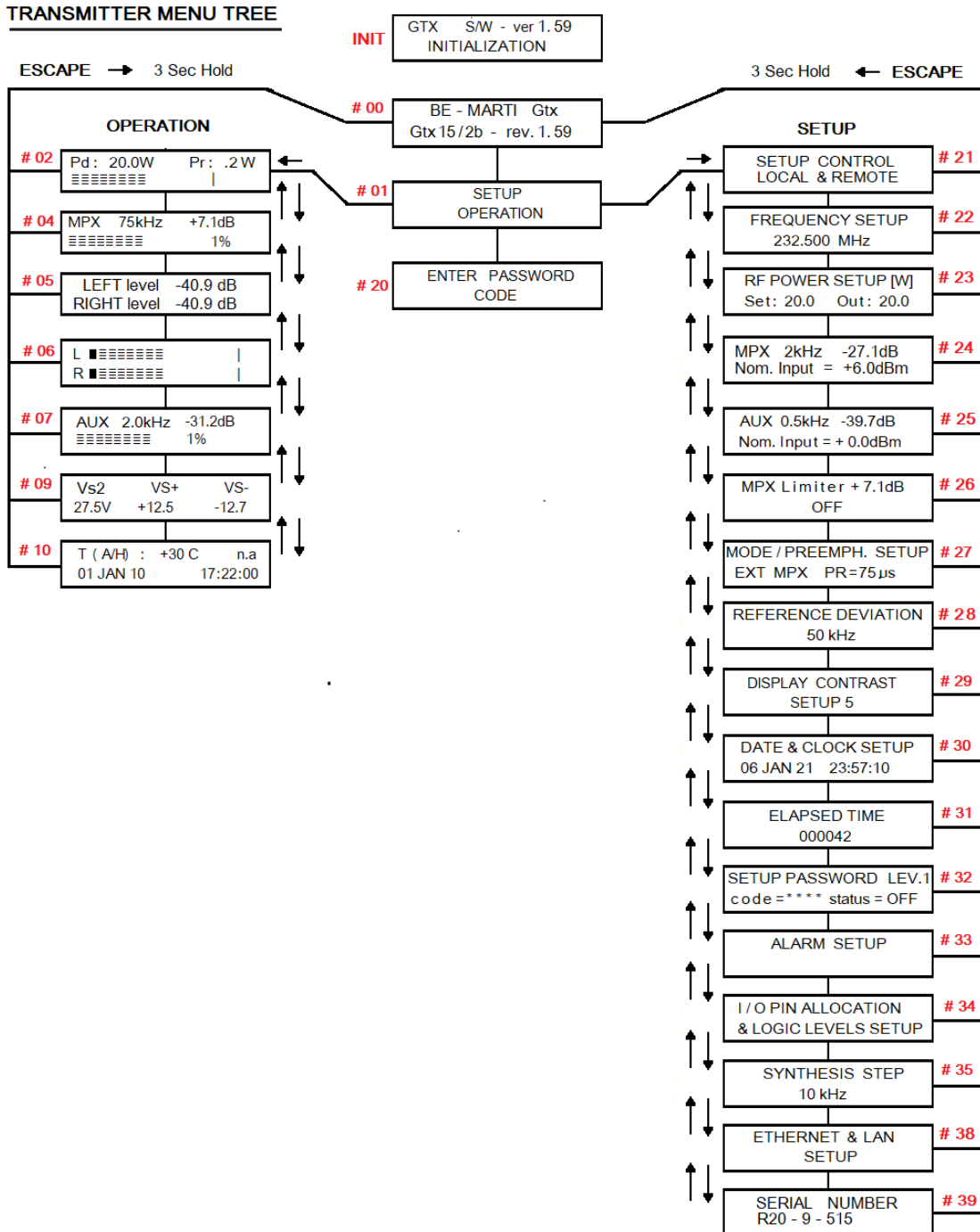

Figure 5 – Transmitter Menu Tree



- OPERATION MENU
- Field #02: Direct & Reflected Power

Pd 20W	Pr .2 W
XXXX	

This field shows the forward or “direct” power, Pd, and the reflected power, Pr, in the VHF models. Transmitter models in the SHF band will not show the reflected power as a circulator is used in the final RF amplifier stage in this band.

- Field #04: Multiplex Signal Level (Output Modulation)

MPX 75.0kHz + 0.0dB
#####

This field shows the actual peak modulation level in dB referenced to the peak deviation in kHz. A pseudo-analog moving bar functions as a modulation meter, leaving a peak mark at its end for 1 or 2 seconds. A vertical bar (|) on this line marks the 0dB position.

- Field #05: Left & Right Signal Level in dB

LEFT level - 3.0dB
RIGHT level - 3.5dB

This field shows the actual left and right peak modulation in dB referenced to 75kHz. The right channel level has no meaning in the absence of an internal stereo-encoder.

The reading is fairly accurate with real audio signals. Some steady state test tones, especially at very low audio frequency, may beat with the discrete ADC conversion sometimes producing reading uncertainty (*aliasing*). In this case the MPX level reading will still correct overall modulation measure.

- Field #06: L & R Signal Level / Analog Meter

L#####	0	
R#####	0	

This field shows the actual left and right peak modulation as two moving bars. A vertical line marks 0dB position and the same considerations as in the previous menu are still valid.

- Field #07: RDS / SCA Auxiliary Modulation Level

AUX	2.0kHz	-31.2dB
#####0		

This field shows the actual modulation for an auxiliary SCA or RDS signal in dB referenced to 7.5kHz or 10% of max peak modulation. The usual level for SCA signal is 0dB (7.5kHz) while standard RDS modulation needs to be set at -11.5dB (2kHz)

- Field #09: Internal Voltages

Vs2	Vs+	Vs-
+27.5V	+12.5	-12.4

This field shows the internal regulated power supply voltages. The Vs+ and Vs- voltages on the GTX & GRX models will typically operate +12.5 ±0.3V and -12.4V (+1/-2V).

The Vs2 battery voltage usually reads Vbat= +27.4 ± 0.4V, when the battery is completely charged and AC mains are on. In case of battery operation, the equipment works satisfactory at any level the range of 22 to 28V.

- Field #10: Temperature, Data and Clock

T(A/H)	+30°C	n.a.
01 Jan 21	23:51:35	

This field shows the equipment's internal temperature in Celsius (°C). The ambient temperature sensor is placed just behind the front panel and it may read higher than the ambient temperature. At full output power and the maximum allowed ambient temperature of +45 °C, the internal temperature could read up to 5 - 6 °C higher. The field software supports heatsink temperature reading (Th) which is not measured on this equipment. There is no Temperature management, only an alarm. Therefore the user is advised not to exceed temperature limits.

Bear in mind that the higher the ambient temperature, the lower the MTBF. As rule of thumb the life is halved each 10 °C the temperature is increased. Assuming 10 year operating life at +25°C, which is not unrealistic, it may become 2.5 years at +45°C.



- **SETUP MENUS**

From this menu branch, equipment parameters may be setup or changed. To enter this section and make changes, Level 2 is required. Some fields are factory set and not intended to change once the product has shipped.

- **Field #21: Local/Remote control setup**

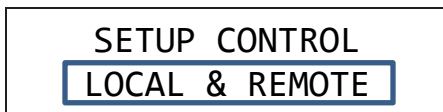

The equipment may be controlled either locally from the front panel or remotely from the I/O lines in the rear port. It is possible to configure the control as shown above, (Remote and Local) or only by Local or by Remote only. In this case the correspondingly displayed options will be:

LOCAL ONLY or REMOTE ONLY

If the apparatus is locked on remote, any attempt to access the setup menu will show the following message:



Pushing "Enter" twice in succession on the knob will access the control Screen and the "REMOTELY LOCKED" line will be selected, allowing it to be changed to "LOCAL & REMOTE" (default setting) or "LOCAL ONLY", if requested..

- **Field #22: Transmission Frequency setup**

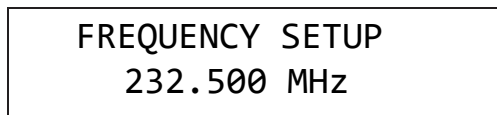

Frequency is set in two steps on either side of the decimal point. In the first step, the integral part of the frequency to the left of the decimal point. The second step is to the right of the decimal point.

- **Field #23: Output Power setup**

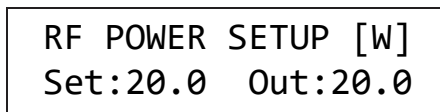

This field permits changing the RF output in accordance with the licensed power level. Two values are shown: the programmed level (Set) and the actual level, (Out). Small variations between Set and Out may be allowed to match the licensed power.

- **Field #24: LF Modulation Input Level setup**

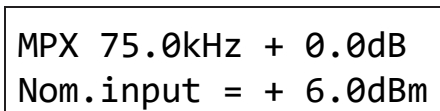

This field sets the main LF input channels sensitivity, i.e. multiplex, left and right channel. Note that the multiplex and right channel share the same circuitry and the sensitivity is set to the same value for all audio /multiplex channels, with a differential error (<0.2dB) at any level. Adjustment range is - 3.5 - +12.5 dBm.

The upper line of the display shows the modulation corresponding to the LF signal currently present, while the bottom line shows the nominal input level for 100% modulation, (75kHz). Increasing the nominal input level consequently reduces the modulation, if the modulating signal remains constant.

- Field #25: Auxiliary Input Level setup

AUX 2.0kHz -31.5dB
Nom.input = + 0.0dBm

This field adjusts the auxiliary channels input sensitivity. Adjustment range is -12 - +4 dBm to produce 10% modulation, corresponding to the deviation of 7.5kHz or -20dB in the upper line of the display. On this line the actual modulation of the channel is shown in real time. On the lower one the nominal value of the sensitivity in dBm, the parameter on which we act in this screen.

- Field #26: Limiter setup

MPX Limiter + 7.1dB
ON

This field sets the limiter action. Threshold level and enable / disable can be adjusted separately. The limiter may be set to the maximum allowed modulation level for 75kHz-peak deviation, (0dB), so that the transmitter prevents signals which would exceed this value, or if regulations allow, the limiting value may be slightly higher to provide some dynamic headroom for some occasional modulation peaks

It is recommended, not to frequently exceed the limiter threshold with modulation peaks. Repeatedly exceeding the threshold can cause a heavy audible distortion.

Conversely, setting the threshold to high above the corresponding deviation level would be no difference with the limiter on or off

- Field #27: Transmission Mode, and Pre-emphasis Setup

MODE/PREEMPH.	SETUP
STEREO	PR 75 μ S

The transmission "modes" (MONO R, STEREO, MONO L+R, EXT MPX), and the pre-emphasis time-constants (0, 25, 50 or 75 μ S) are set up here. The pre-emphasis is only active on audio channels and not an external multiplex signal.

Set pre-emphasis to the correct standard for your area. Countries in North and South America use 75 μ S pre-emphasis, while Europe and some other countries will use 50 μ S

- Field #28: Reference Deviation setup

REFERENCE DEVIATION
75 kHz

The field selects the deviation to reference 0dB of modulation. The standard (default) is 75kHz but you can choose any value between 5 and 75kHz, and specifically 50, 40 or 25 kHz.

- Field #29: Display Contrast setup

DISPLAY CONTRAST
SETUP 5

It is possible to vary the display contrast. The setting range is 0 to 7.

- Field #30: Time & Date setup

DATE & CLOCK SETUP
31 JAN 21 12:45:00

This field edits date or time. The clock is configured for 24 hour clock time.

- Field #31: Elapsed Time

ELAPSED TIME
000356 HOURS

This field shows the elapsed time of service whether the transmitter is on the air or in stand-by and begins counting when AC mains are applied. This is set in the factory and is not a setting that can be changed.



- Field #32: Password Management

```
PASSWORD LEVEL 1
code=**** status=OFF
```

This field allows status, ON/OFF and the level, 1 or 2 to be changed as well as the password itself.

When a Level, or Status, or Password is changed, it is always required to confirm the correct password for that level: For example, we will change the Level 1 status to On by positioning on the word OFF, then rotating knob to change from OFF to ON. The following request for password is displayed:

```
ENTER PASSWORD
```

```
.....
```

After the correct password has been entered the screen will change to the following:

```
CONFIRM PASSWORD 1
P001 N
```

In the example, the password, "P001", is displayed in the lower display followed by the letter "N" indicating the status "ON". If the example were reversed and we changed the status from ON to OFF, the steps and confirmation display would be the same except for the letters "FF" to indicate OFF:"

```
CONFIRM PASSWORD 1
P001 FF
```

With password enabled, any attempt to access the equipment will cause the request of a correct password. Failure to do so or an error in entering the password will cause a time-out process during which no command will be recognized by the equipment. The timeout starts after the last action of the jog knob plus the default timeout of 3 minutes. After which it will be possible to retry access and input a valid password.

```
INVALID PASSWORD!
```

```
.....
```

If an incorrect password is entered, it will be necessary to wait for the end of the resulting time-out before another possibility is granted. The following error message is generated, and the display remains frozen, preventing further operations until the time-out. Subsequently, it is possible to exit the Screen with "Escape" and then possibly try again.



- **Field #33: Alarm Setup and Display**

This menu shows the various alarm conditions which are associated with the general alarm line, either located the front panel LED and the remote I/O signaling line. Some of them may be edited for their threshold level while others are factory set and fixed. The following table lists all them:

- ALARM SETUP
- TEMPERATURE: ON
- PLL UNLOCK: ON
- HIGH VSWR: ON
- LOW POWER: ON/OFF
- NO MODULATION: ON/OFF
- OVERMODULATION: ON/OFF
- TEMP. AMBIENT: 55°C TEMP.
- HEATSINK: XX°C
- MAX [REFL.PW](#): XX.X W
- MIN [DIR. PW](#): XX.X W
- NO MOD. LEV.: -15.9dB
- NO MOD. TIME: 90sec
- UNLOCK TIME: 60sec

If the alarm is enabled, the red front panel "Alarm" LED and the corresponding remote signal line will turn on. At the same time a flashing line will superimpose on the display specifying the highest priority pending alarm. This alarm line will stop flashing whenever the control jog knob is moved to permit navigation in the control and setup menus; at timeout, i.e. 2 or 3 minutes from the last access it will superimpose again till alarm resets. The alarm reset is automatic and requires no action from the user. The equipment has no alarm historical memory

- **Field #34: I/O Pin Allocation and Logic Level setup**

**I/O PIN ALLOCATION
& LOGIC LEVELS SETUP**

As described in Section 3.3, there are 3 I/O lines which are associated to corresponding pins of the parallel remote I/O connector on the rear panel. This field permits setup to the corresponding function associated to each pin with the following options ("NOT DEFINED" means that no alternate function is assigned):

Inputs:

PIN 6: RF ENABLE
NOT DEFINED

Outputs:

PIN 2: ON THE AIR
REMOTE LOCKED
PIN 7: ALARM
NOT DEFINED

The factory default value is the one indicated on the first line. Subsequently, on the same menu it is possible to choose the high or low logic level associated with the alarm. When the equipment is locked to remote control operation, it is not possible to alter any preselection before unlocking this control.

- Field #35: Synthesis setup

SYNTHESIS SETUP 10kHz

This field displays the synthesis step frequency and can be selected, 10 or 25kHz

- Field #37: Ethernet & Lan setup

Field #37 is for the ETHERNET & LAN hardware option. The control and display software will have this ready for the option in both the Transmitter and Receiver. Ethernet settings, IP, Mask and Gateway may be changed in this field.

ETHERNET & LAN SETUP

The default settings for Ethernet and LAN are as follows:

IP:	192.168.001.247
Mask:	255.255.255.000
Gateway	192.168.001.250
ID:	admin
Password	*****



4.3.3 RECEIVER FIELDS & MENU TREE

The Receiver Menu is structured similar to the Transmitter Menu. Many of the field details have already been described in the Transmitter section and may not be listed here. Some field numbers may be listed again when additional or separate information is provided.

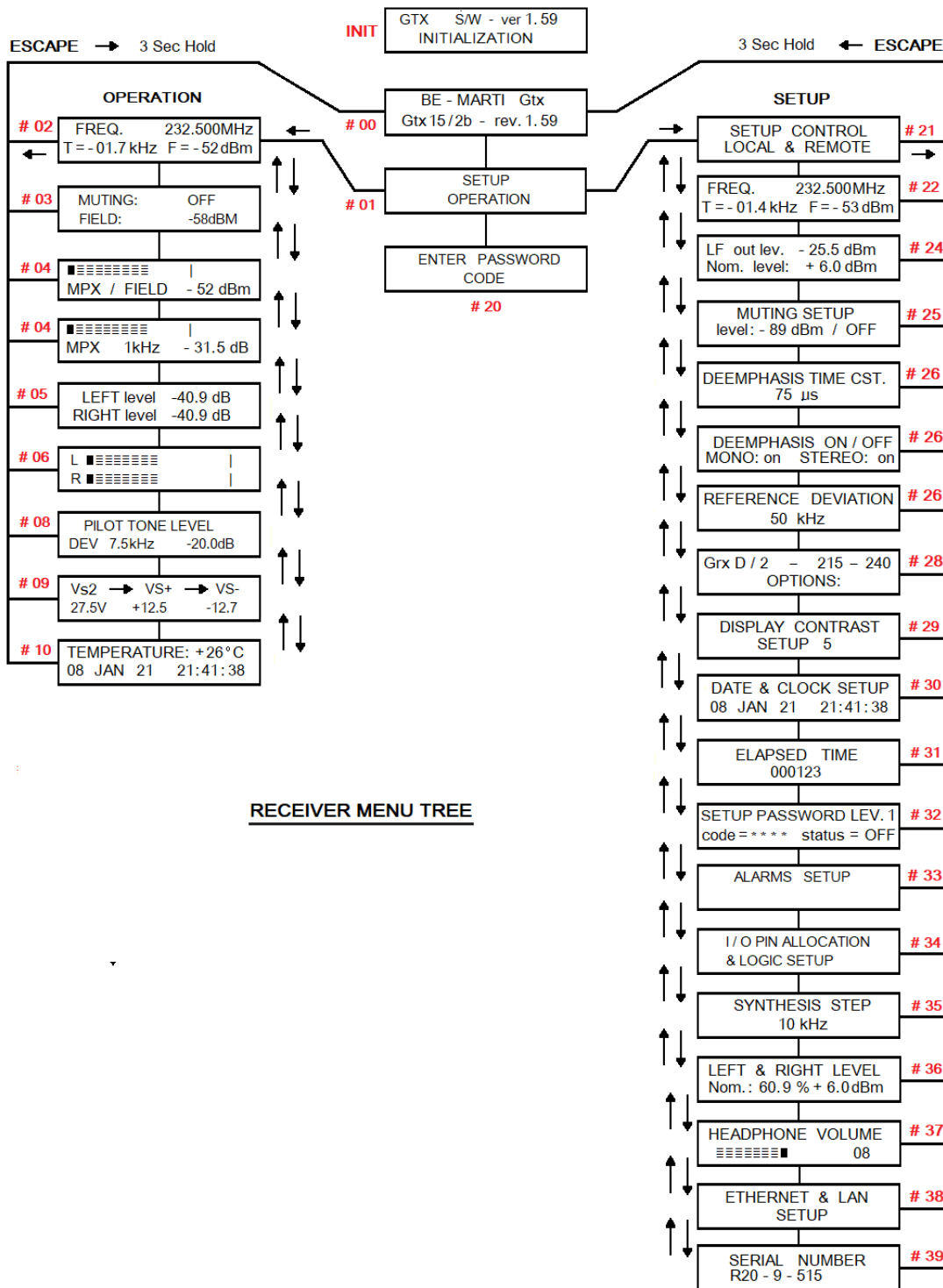

RECEIVER MENU TREE

Figure 6 - Receiver Menu Tree



- OPERATION MENU
- Field #02: Receiver Frequency

```
Rx #0    232.500MHz
t=-01.7kHz  F= -52dBm
```

This display shows the frequency, the tuning of the received signal (T) in kHz with respect to the nominal frequency within just over ± 100 kHz and the field strength (F) in dB. In the absence of received signal (Sin < -90 dBm) the tuning indication is random. The signal is properly tuned when "TUNING" is within ± 6.0 kHz.

The "Rx [N]" parameter, with N between 0 and 6 shows the frequency set for the device in the case of the optional control function in the N + 1 system. The number 0 is the default.

- Field #03: Received RF Field and Muting

```
FIELD    -58dBm
MUTING OFF
```

Here the received signal field in dBm is displayed and whether or not the muting function is active.

- Field #04: MPX Modulation and Reception Field

```
##          |
MPX / FIELD -52dBm
```

This field displays composite modulation (MPX) via an analog moving bar and received field strength in dBm.

- Field #04 Modulation of the Multiplex Signal

```
MPX 75kHz  +0.0dB
##### |
```

This field shows the actual frequency deviation of the received signal due to the whole multiplex modulation, as shown on the corresponding transmitter field.

Note that the deviation reading is very precise with clean channel reception. However, in the absence of received field or with very weak signal, noise will affect the accuracy, which will show a much wider deviation than actual.

- Fields #05 & #06: L and R Decoded Output Levels

```
LEFT level - 3.0dB
RIGHT level - 4.5dB
```



```
L##### 0 |
R##### 0 |
```

Fields 05 & 06 are only displayed if the optional internal stereo decoder is present. Field 05 displays the peak levels in the decoded audio signal on the left and right channel, expressed in dB relative to 75kHz deviation. Field 06 shows the same information with the analog bar meters.

- Field #08: Stereo Pilot Frequency level

```
PILOT TONE LEVEL
DEV. 7.5kHz -20.0dB
```

Again, this field only displays in presence of the optional stereo decoder board. The modulation for the 19kHz stereo pilot tone embedded in the multiplex signal, is displayed with excellent precision. There is no need to mute the modulation or to do any special action to measure it

- SETUP MENUS
- Field #22: Frequency setup

```
FREQ. 2470.175 MHz
F= -55dBm T=+ 1.2kHz
```

This field sets the receiver frequency in a similar manner as in the transmitters, (in two steps on either side of the decimal point).. The bottom line shows the associated received field and center tuning.

The frequency changing is in real time, except in a major frequency changes which will lag for a few second in the bottom line..

- Field #24: LF Output Level setup

```
LF out lev. + 2.5dBm
Nom. level: + 6.0dBm
```

The Main LF outputs, either the Multiplex (MPX) and Mono signals are set simultaneous in this field. The first row displays the actual level in dBm, while in the bottom row displays and sets the nominal output level referenced to 75kHz deviation. The range is -1.5 to +12dBm

- Field #25: Receiver Muting setup

```
MUTING SETUP
LEVEL: -75DB / OFF
```

In this field, the user may vary the insertion level of the muting circuit and its intervention. Suitable levels are -70 to -80dBm for stereo signals and -85 to -90dBm for mono signals, depending on the received signal strength. The muting level is unrelated to the field alarm level which may be set differently by its own menu (see alarm setup, menu #33)

By setting "ON" or "OFF", the muting circuit may be enabled or disabled either by "mistuning alarm" or remote control function.

- Field #26: De-emphasis setup

DEEMPHASIS TIME CST 75 μ S

DEEMPHASIS ON / OFF MONO: ON STEREO: ON
--

This field sets the de-emphasis time-constant between 0, 25, 50 and 75 μ s. The de-emphasis function maybe separately set for the mono and the stereo outputs, if the stereo decoded is present

- Field #28: Optional Boards Detection

OPTIONS: STEREO DECODER: NO

In these fields, the software detection of optional internal boards are displayed and depending on option, setups may be made in the equipment. The stereo decoder board is the most common main option in the receiver; while other boards may be added in the future or are available in other bands. Depending on the options detected, additional windows will display in the setup branch in sequence in front of Field #29 "Display Contrast".



- **Field #33: Alarm setup and display**

As in the transmitter this field displays the various alarms that sum up to the general alarm signal, and allow some changes to them. The following table lists the alarms for the receiver:

- ALARM SETUP
- TEMPERATURE: ON
- PLL UNLOCK: ON
- LOW RF INPUT: ON/OFF
- MISTUNING: ON/OFF
- NO MODULATION: ON/OFF
- OVERMODULATION: ON/OFF
- HIGH TEMPERAT.: 55°C
- LOW RF INPUT: -xxdBm
- NO MOD. LEV.: -15.9dB
- NO MOD. TIME: 90sec
- UNLOCK TIME: 60sec

- **Field #34: I/O pin allocation and logic level setup**

As described in the proper section, there are at least 4 I/O lines which may be associated to corresponding pins of the parallel remote I/O connector on the rear panel. This submenu permits to choose the corresponding function to associate to the pins with the following options

Inputs:

PIN 6: AUDIO MUTING
REMOTE LOCK

Outputs:

PIN 2: MODULATION OK
REMOTE LOCKED
PIN 7: ALARM
FIELD GOOD
PIN 3, 8: FIELD GOOD
ALARM

The factory default is the first line for each pin. All of these lines may be preset active high or low in the same menu.

- Field #36 Left & Right Level

<p>LEFT & RIGHT LEVEL Nom: 60.9% + 6.0dBm</p>

This field displays based on the advance stereo decoder card option detected. With this option, it is possible to vary the output level of the stereo signal on the decoded rear outputs in steps equal to or less than 0.1 dB over almost the entire range between -8.4 and +12.0 dBm. The percentage does not refer to the output level but to the position of the internal electronic attenuator which has 256 steps.

- Field #37 Headphone Volume

<p>HEADPHONE VOLUME ===== 08</p>
--

Currently, Fields #36 and #37 are in the control software only. When the advanced stereo decoder card and the relative headphone output are detected, the relative output level or volume can be varied from here. Again, the variation is logarithmic for a more constant variation effect for each step of the control. There are 16 steps of 3 dB each for a dynamic range of 45 dB between about 0.5 and 100mW on a 16 Ohm headphone.

- Field #39 Serial Number

<p>SERIAL NUMBER __R20-9-515</p>

This field is factory set displays at the end of the Setup Branch.



5 SERVICE & CHASSIS DIAGRAMS

Service and repair is limited to the overall mechanical and module interconnect wiring of the GTX and GRX. The following diagrams are provided for module and sub assembly identification of replacement modules if needed and the units cannot be returned to the factory for service.



5.1 Transmitter Drawings

5.1.1 GTX Mechanical Layout - VHF & UHF Models

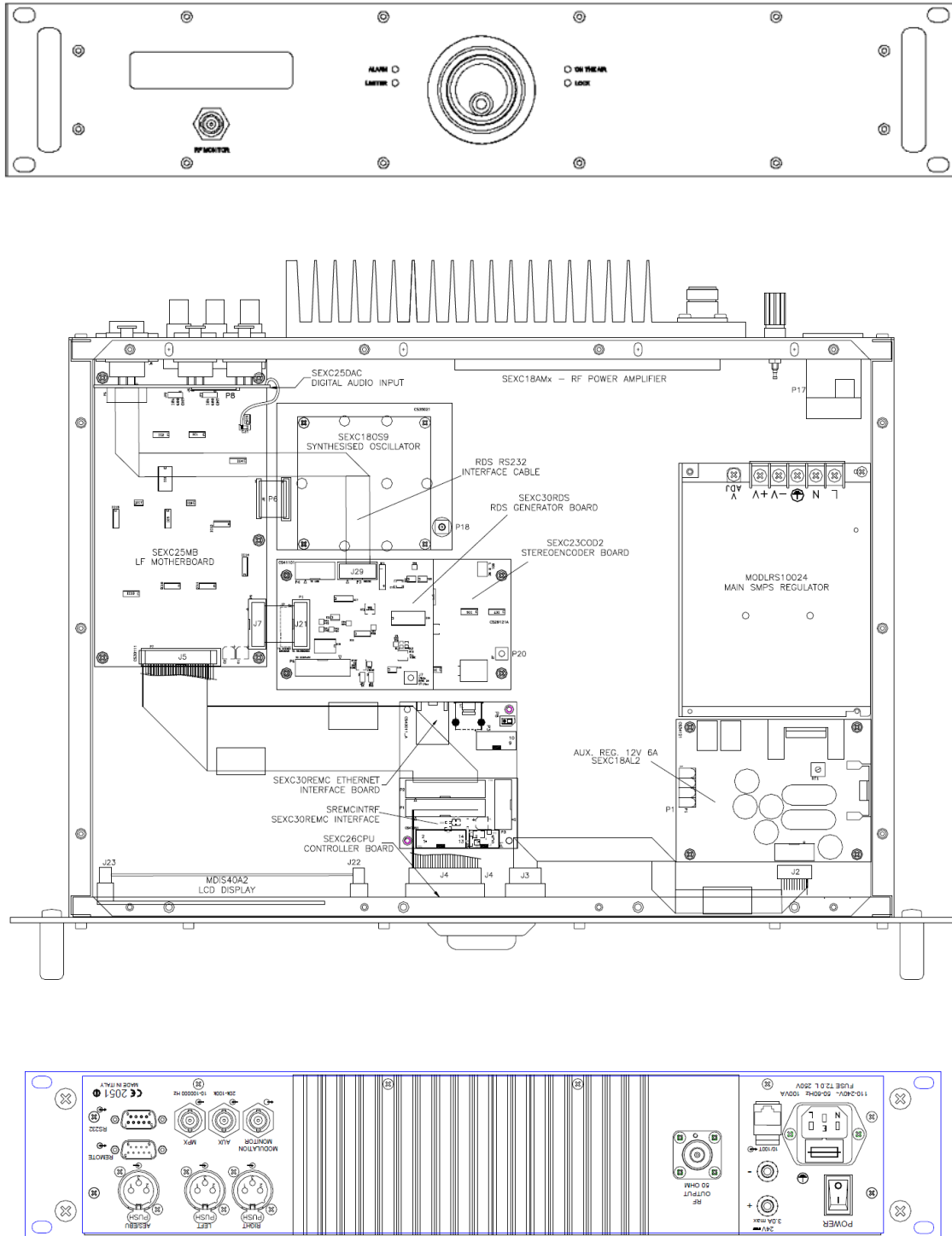

Figure 7 – Transmitter Mechanical - VHF & UHF Models

5.2 Receiver Drawings

5.2.1 GRX Mechanical Layout – VHF & UHF Models

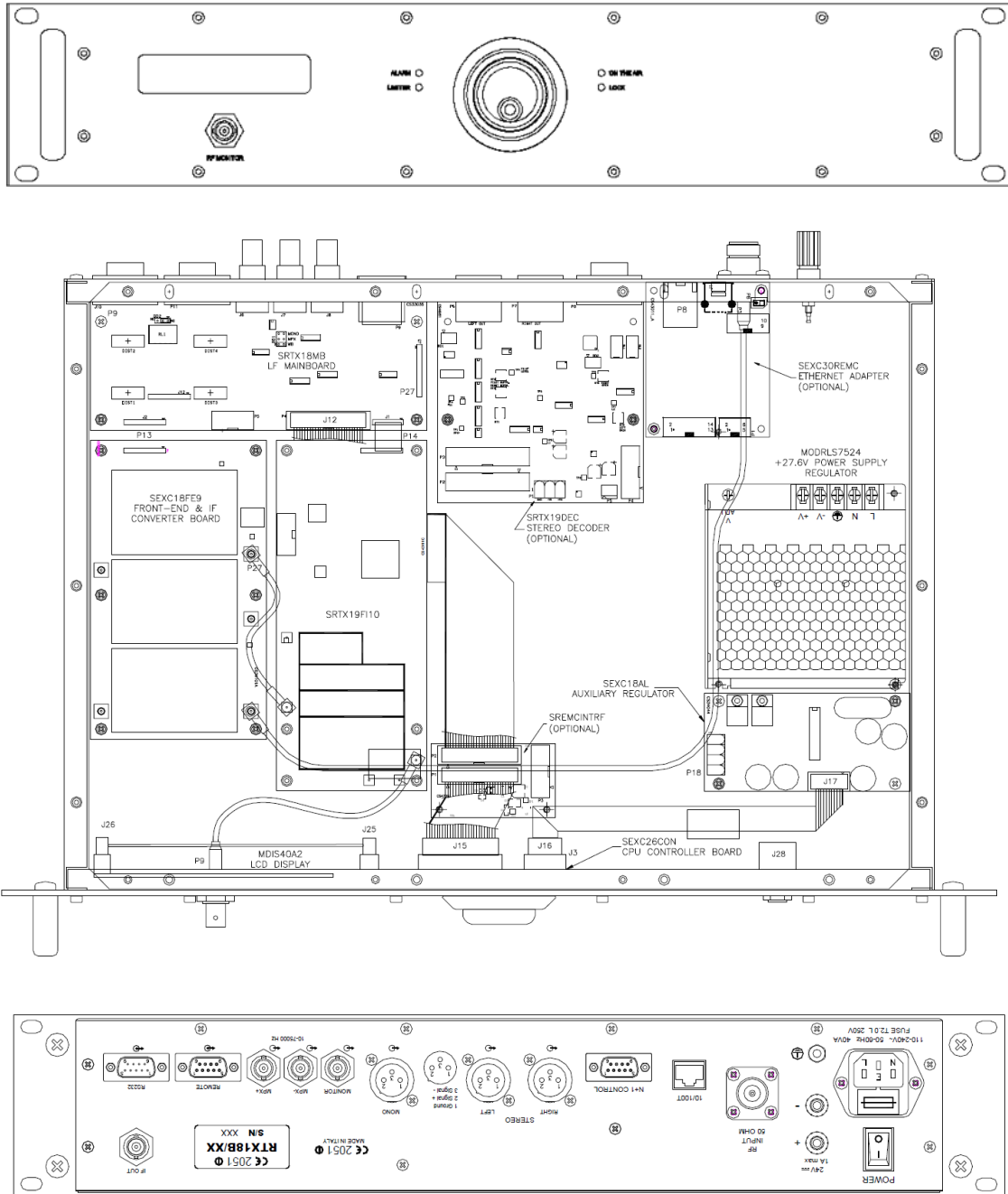

Figure 8 – Receiver Layout - VHF & UHF

