



RF MEASUREMENT REPORT

FCC ID: DD4SLXD3H55
Applicant: Shure Incorporated
Product: Plug-on Wireless Transmitter
Model No.: SLXD3 H55
Brand Name: 
FCC Classification: Part 15 Wireless Microphone (DWM)
FCC Rule Part(s): Part 15 Subpart C (Section 15.236)
Result: Complies
Received Date: 2023-04-14
Test Date: 2023-04-20 ~ 2023-05-04

Reviewed By: _____
Jame Yuan

Approved By: _____
Robin Wu



The test results relate only to the samples tested.
The test results shown in the test report are traceable to the national/international standards through the calibration of the equipment and evaluated measurement uncertainty herein.
The test report shall not be reproduced except in full without the written approval of MRT Technology (Suzhou) Co., Ltd.

Revision History

Report No.	Version	Description	Issue Date	Note
2304RSU032-U4	V01	Initial Report	2023-08-05	Valid

CONTENTS

Description	Page
CONTENTS	3
1. General Information	5
1.1. Applicant	5
1.2. Manufacturer	5
1.3. Testing Facility	5
1.4. Product Information.....	6
1.5. Radio Specification under Test	6
1.6. Working Frequencies	6
2. Test Configuration	7
2.1. Test Mode	7
2.2. Test System Connection Diagram	7
2.3. Test Software	7
2.4. Applied Standards.....	8
2.5. Test Environment Condition.....	8
3. Measuring Instrument	9
4. Decision Rules and Measurement Uncertainty.....	10
4.1. Decision Rules	10
4.2. Measurement Uncertainty.....	10
5. Test Result	11
5.1. Summary.....	11
5.2. 99% Occupied Bandwidth Measurement.....	12
5.2.1. Test Limit.....	12
5.2.2. Test Procedure.....	12
5.2.3. Test Setting	12
5.2.4. Test Setup	12
5.2.5. Test Result	12
5.3. Frequency Tolerance Measurement	13
5.3.1. Test Limit.....	13
5.3.2. Test Procedure.....	13
5.3.3. Test Setting	13
5.3.4. Test Setup	14
5.3.5. Test Result	14
5.4. Necessary Bandwidth Measurement	15
5.4.1. Test Limit.....	15

5.4.2.	Test Procedure	15
5.4.3.	Test Setting	15
5.4.4.	Test Setup	15
5.4.5.	Test Result	15
5.5.	Output Power Measurement	16
5.5.1.	Test Limit	16
5.5.2.	Test Procedure	16
5.5.3.	Test Setting	16
5.5.4.	Test Setup	16
5.5.5.	Test Result	16
5.6.	Radiated Spurious Emission Measurement.....	17
5.6.1.	Test Limit	17
5.6.2.	Test Procedure	17
5.6.3.	Test Setting	17
5.6.4.	Test Setup	18
5.6.5.	Test Result	18
5.7.	AC Conducted Emissions Measurement.....	19
5.7.1.	Test Limit	19
5.7.2.	Test Setup	19
5.7.3.	Test Result	19
Appendix A – Test Result.....		20
A.1	99% Occupied Bandwidth Test Result.....	20
A.2	Frequency Tolerance Test Result.....	21
A.3	Necessary Bandwidth Test Result	22
A.4	Output Power Test Result	31
A.5	Radiated Spurious Emission Test Result.....	32
A.6	AC Conducted Emissions Test Result	33
Appendix B - Test Setup Photograph		35
Appendix C - EUT Photograph		36

1. General Information
1.1. Applicant

Shure Incorporated
 5800 West Touhy Avenue, Niles, IL 60714-4608, USA

1.2. Manufacturer

Shure Incorporated
 5800 West Touhy Avenue, Niles, IL 60714-4608, USA

1.3. Testing Facility

<input checked="" type="checkbox"/>	<table border="1" style="width: 100%; border-collapse: collapse;"> <tr> <td colspan="2" style="padding: 5px;">Test Site – MRT Suzhou Laboratory</td> </tr> <tr> <td colspan="2" style="padding: 5px;">Laboratory Location (Suzhou - Wuzhong)</td> </tr> <tr> <td colspan="2" style="padding: 5px;">D8 Building, No.2 Tian'edang Rd., Wuzhong Economic Development Zone, Suzhou, China</td> </tr> <tr> <td colspan="2" style="padding: 5px;">Laboratory Location (Suzhou - SIP)</td> </tr> <tr> <td colspan="2" style="padding: 5px;">4b Building, Liando U Valley, No.200 Xingpu Rd., Shengpu Town, Suzhou Industrial Park, China</td> </tr> <tr> <td colspan="2" style="padding: 5px;">Laboratory Accreditations</td> </tr> <tr> <td style="padding: 5px;">A2LA: 3628.01</td> <td style="padding: 5px;">CNAS: L10551</td> </tr> <tr> <td style="padding: 5px;">FCC: CN1166</td> <td style="padding: 5px;">ISED: CN0001</td> </tr> <tr> <td style="padding: 5px; vertical-align: top;">VCCI:</td> <td style="padding: 5px;"> <input type="checkbox"/>R-20025 <input type="checkbox"/>G-20034 <input type="checkbox"/>C-20020 <input type="checkbox"/>T-20020 <input type="checkbox"/>R-20141 <input type="checkbox"/>G-20134 <input type="checkbox"/>C-20103 <input type="checkbox"/>T-20104 </td> </tr> </table>	Test Site – MRT Suzhou Laboratory		Laboratory Location (Suzhou - Wuzhong)		D8 Building, No.2 Tian'edang Rd., Wuzhong Economic Development Zone, Suzhou, China		Laboratory Location (Suzhou - SIP)		4b Building, Liando U Valley, No.200 Xingpu Rd., Shengpu Town, Suzhou Industrial Park, China		Laboratory Accreditations		A2LA: 3628.01	CNAS: L10551	FCC: CN1166	ISED: CN0001	VCCI:	<input type="checkbox"/> R-20025 <input type="checkbox"/> G-20034 <input type="checkbox"/> C-20020 <input type="checkbox"/> T-20020 <input type="checkbox"/> R-20141 <input type="checkbox"/> G-20134 <input type="checkbox"/> C-20103 <input type="checkbox"/> T-20104
Test Site – MRT Suzhou Laboratory																			
Laboratory Location (Suzhou - Wuzhong)																			
D8 Building, No.2 Tian'edang Rd., Wuzhong Economic Development Zone, Suzhou, China																			
Laboratory Location (Suzhou - SIP)																			
4b Building, Liando U Valley, No.200 Xingpu Rd., Shengpu Town, Suzhou Industrial Park, China																			
Laboratory Accreditations																			
A2LA: 3628.01	CNAS: L10551																		
FCC: CN1166	ISED: CN0001																		
VCCI:	<input type="checkbox"/> R-20025 <input type="checkbox"/> G-20034 <input type="checkbox"/> C-20020 <input type="checkbox"/> T-20020 <input type="checkbox"/> R-20141 <input type="checkbox"/> G-20134 <input type="checkbox"/> C-20103 <input type="checkbox"/> T-20104																		
<input type="checkbox"/>	<table border="1" style="width: 100%; border-collapse: collapse;"> <tr> <td colspan="2" style="padding: 5px;">Test Site – MRT Shenzhen Laboratory</td> </tr> <tr> <td colspan="2" style="padding: 5px;">Laboratory Location (Shenzhen)</td> </tr> <tr> <td colspan="2" style="padding: 5px;">1G, Building A, Junxiangda Building, Zhongshanyuan Road West, Nanshan District, Shenzhen, China</td> </tr> <tr> <td colspan="2" style="padding: 5px;">Laboratory Accreditations</td> </tr> <tr> <td style="padding: 5px;">A2LA: 3628.02</td> <td style="padding: 5px;">CNAS: L10551</td> </tr> <tr> <td style="padding: 5px;">FCC: CN1284</td> <td style="padding: 5px;">ISED: CN0105</td> </tr> </table>	Test Site – MRT Shenzhen Laboratory		Laboratory Location (Shenzhen)		1G, Building A, Junxiangda Building, Zhongshanyuan Road West, Nanshan District, Shenzhen, China		Laboratory Accreditations		A2LA: 3628.02	CNAS: L10551	FCC: CN1284	ISED: CN0105						
Test Site – MRT Shenzhen Laboratory																			
Laboratory Location (Shenzhen)																			
1G, Building A, Junxiangda Building, Zhongshanyuan Road West, Nanshan District, Shenzhen, China																			
Laboratory Accreditations																			
A2LA: 3628.02	CNAS: L10551																		
FCC: CN1284	ISED: CN0105																		
<input type="checkbox"/>	<table border="1" style="width: 100%; border-collapse: collapse;"> <tr> <td colspan="2" style="padding: 5px;">Test Site – MRT Taiwan Laboratory</td> </tr> <tr> <td colspan="2" style="padding: 5px;">Laboratory Location (Taiwan)</td> </tr> <tr> <td colspan="2" style="padding: 5px;">No. 38, Fuxing 2nd Rd., Guishan Dist., Taoyuan City 333, Taiwan (R.O.C.)</td> </tr> <tr> <td colspan="2" style="padding: 5px;">Laboratory Accreditations</td> </tr> <tr> <td colspan="2" style="padding: 5px;">TAF: L3261-190725</td> </tr> <tr> <td style="padding: 5px;">FCC: 291082, TW3261</td> <td style="padding: 5px;">ISED: TW3261</td> </tr> </table>	Test Site – MRT Taiwan Laboratory		Laboratory Location (Taiwan)		No. 38, Fuxing 2nd Rd., Guishan Dist., Taoyuan City 333, Taiwan (R.O.C.)		Laboratory Accreditations		TAF: L3261-190725		FCC: 291082, TW3261	ISED: TW3261						
Test Site – MRT Taiwan Laboratory																			
Laboratory Location (Taiwan)																			
No. 38, Fuxing 2nd Rd., Guishan Dist., Taoyuan City 333, Taiwan (R.O.C.)																			
Laboratory Accreditations																			
TAF: L3261-190725																			
FCC: 291082, TW3261	ISED: TW3261																		

1.4. Product Information

Product Name	Plug-on Wireless Transmitter
Model No.	SLXD3 H55
Serial No.	3CC23617366 (Radiated Testing) 3CC23618076 (Conducted Testing)
Frequency Range	514 ~ 558 MHz
Power Type	Two AA batteries or Li-ion battery(3.6Vdc) or USB (5Vdc)
Operating Temperature	-18 ~ 50°C
Accessories	
Rechargeable Li-ion Battery	Model: SB903 Output: 3.6Vdc, 1200mAh, 4.32Wh

Note: The information of EUT was provided by the manufacturer, and the accuracy of the information shall be the responsibility of the manufacturer.

1.5. Radio Specification under Test

Frequency Range	514 ~ 558 MHz
Declared Power Level	1mW & 10mW & 30mW
Type of Modulation	4FSK
Channel Spacing	25kHz
Antenna Type	Dipole
Antenna Gain	0.70 dBi

Note: Power level and transmit frequency can be selected using the front panel controls.

1.6. Working Frequencies

Bottom Channel (MHz)	Middle Channel (MHz)	Top Channel (MHz)
514.000	536.000	558.000

2. Test Configuration

2.1. Test Mode

Mode 1: Transmit one channel at the fixed power level

2.2. Test System Connection Diagram

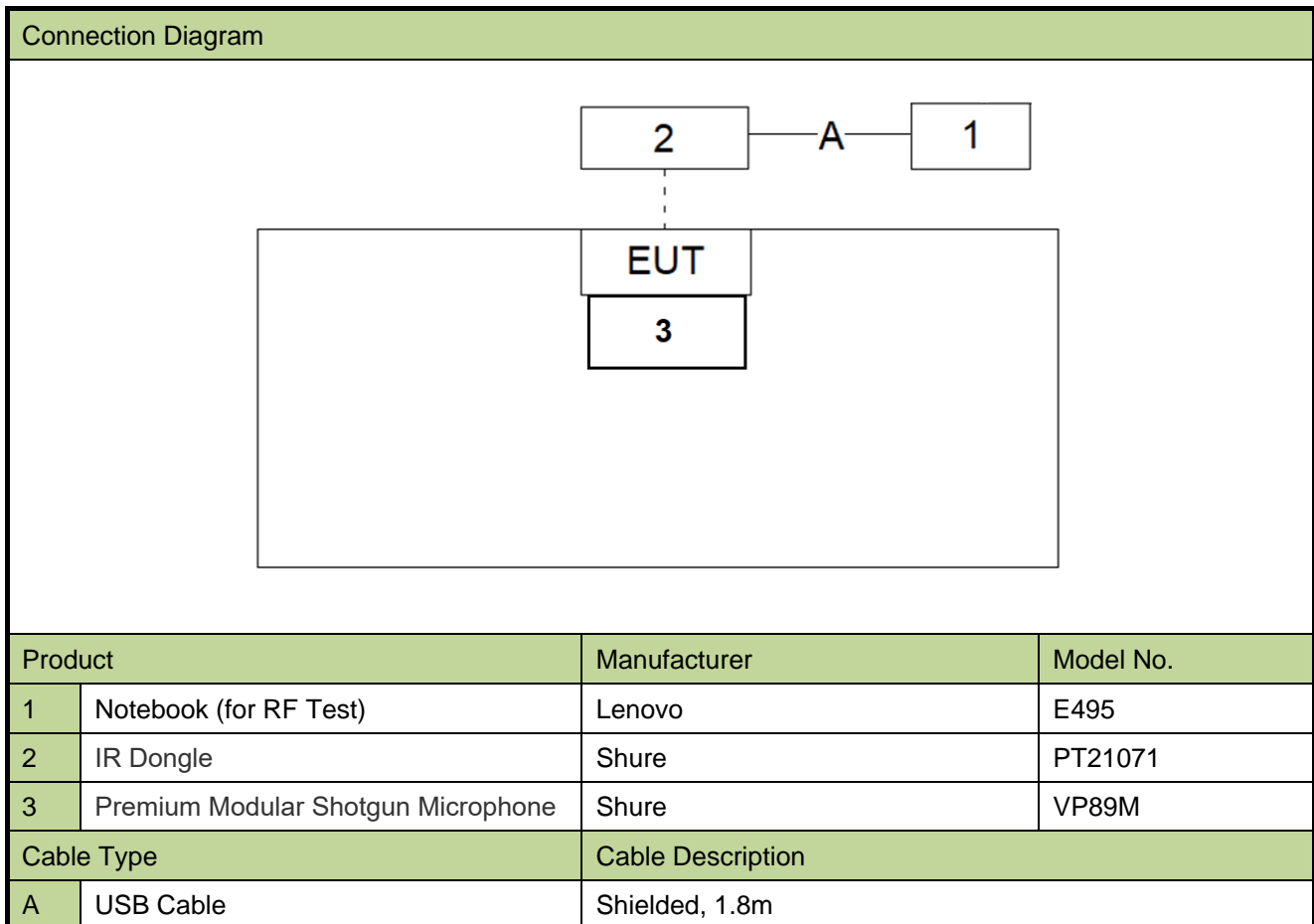

2.3. Test Software

The test utility software used during testing was “teraterm”, and the version was V4.85, all test commands were provided by the manufacturer.

2.4. Applied Standards

According to the specifications of the manufacturer, the EUT must comply with the requirements of the following standards:

- FCC Part 15.236
- KDB 206256 D01v02r01
- ANSI C63.10-2013
- ETSI EN 300 422 - 1 V 1.4.2

2.5. Test Environment Condition

Ambient Temperature	15 ~ 35°C
Relative Humidity	20 ~ 75%RH

3. Measuring Instrument

Instrument	Manufacturer	Model No.	Asset No.	Cali. Interval	Cali. Due Date	Test Site
Two-Line V-Network	R&S	ENV216	MRTSUE06002	1 year	2023-06-04	WZ-SR2
Shielding Room	MIX-BEP	WZ-SR2	MRTSUE06215	5 years	2026-12-20	WZ-SR2
Thermohygrometer	testo	608-H1	MRTSUE06404	1 year	2023-06-06	WZ-SR2
EMI Test Receiver	R&S	ESR3	MRTSUE06909	1 year	2023-10-27	WZ-SR2
Thermohygrometer	testo	608-H1	MRTSUE06402	1 year	2023-06-06	WZ-SR5
Shielding Room	HUAMING	WZ-SR5	MRTSUE06442	N/A	N/A	WZ-SR5
USB Power Sensor	Keysight	U2021XA	MRTSUE06446	1 year	2023-06-04	WZ-SR5
Signal Analyzer	Keysight	N9010B	MRTSUE06457	1 year	2023-06-04	WZ-SR5
Attenuator	MVE	MVE2213	MRTSUE11060	1 year	2023-06-09	WZ-SR5
Attenuator	MVE	MVE2213	MRTSUE11072	1 year	2023-06-09	WZ-SR5
Temperature Chamber	BAOYT	BYH-150CL	MRTSUE06051	1 year	2023-10-08	WZ-TR3
Thermohygrometer	testo	608-H1	MRTSUE06401	1 year	2023-06-06	WZ-TR3
Signal Analyzer	Keysight	N9010B	MRTSUE07027	1 year	2023-11-25	WZ-TR3
TRILOG Antenna	Schwarzbeck	VULB 9162	MRTSUE06022	1 year	2023-05-20	WZ-AC2
EMI Test Receiver	Agilent	N9038A	MRTSUE06125	1 year	2023-06-04	WZ-AC2
Thermohygrometer	Mingle	ETH529	MRTSUE06170	1 year	2023-11-27	WZ-AC2
Horn Antenna	Schwarzbeck	BBHA 9120D	MRTSUE06171	1 year	2023-10-13	WZ-AC2
Preamplifier	Schwarzbeck	BBV 9718	MRTSUE06176	1 year	2023-05-08	WZ-AC2
Anechoic Chamber	RIKEN	WZ-AC2	MRTSUE06213	1 year	2023-04-21	WZ-AC2
				1 year	2024-04-20	WZ-AC2
Thermohygrometer	testo	608-H1	MRTSUE11038	1 year	2023-11-01	WZ-AC2

Software	Version	Function
EMI Software	V3.0.0	EMI Test Software
Controller_MF 7802	1.02	RE Antenna & Turntable
BenchVue Power Meter	2018.1	Power

4. Decision Rules and Measurement Uncertainty

4.1. Decision Rules

The Decision Rule is based on Simple Acceptance in accordance with ISO Guide 98-4: 2012 Clause 8.2. (Measurement uncertainty is not taken into account when stating conformity with a specified requirement.)

4.2. Measurement Uncertainty

Where relevant, the following test uncertainty levels have been estimated for tests performed on the EUT as specified in CISPR 16-4-2. This uncertainty represents an expanded uncertainty expressed at approximately the 95% confidence level using a coverage factor of $k = 2$.

AC Conducted Emission Measurement	
The maximum measurement uncertainty is evaluated as:	
9kHz~150kHz:	3.58dB
150kHz~30MHz:	3.20dB
Radiated Emission Measurement	
The maximum measurement uncertainty is evaluated as:	
Coaxial:	9kHz~30MHz: 2.59dB
Coplanar:	9kHz~30MHz: 2.60dB
Horizontal:	30MHz~200MHz: 3.85dB
	200MHz~1GHz: 4.36dB
	1GHz~40GHz: 4.98dB
Vertical:	30MHz~200MHz: 4.06dB
	200MHz~1GHz: 5.28dB
	1GHz~40GHz: 4.91dB
Spurious Emissions, Conducted	
Measuring Uncertainty for a Level of Confidence of 95% ($U=2Uc(y)$):	
2.3dB	
Output Power	
Measuring Uncertainty for a Level of Confidence of 95% ($U=2Uc(y)$):	
1.5dB	
Occupied Bandwidth	
Measuring Uncertainty for a Level of Confidence of 95% ($U=2Uc(y)$):	
3.2%	

5. Test Result

5.1. Summary

FCC Part Section(s)	Test Description	Test Condition	Test Result
15.236(f)(2)	Occupied Bandwidth	Conducted	Pass
15.236(f)(3)	Frequency Tolerance		Pass
15.236(g)	Necessary Bandwidth		Pass
15.236(d)(1)	RF Output Power		Pass
15.236(g)	Radiated Spurious Emission	Radiated	Pass
15.207	AC Conducted Emissions 150kHz - 30MHz	Line Conducted	Pass

Notes:

- 1) The analyzer plots shown in this section were all taken with a correction table loaded into the analyzer. The correction table was used to account for the losses of the cables and attenuators used as part of the system to connect the EUT to the analyzer at all frequencies of interest.
- 2) All modes of operation and data rates were investigated. For radiated emission test, every axis (X, Z) was also verified. The test results shown in the following sections represent the worst emissions.
- 3) For different power levels, except RF output power and necessary bandwidth items were evaluated all power levels, any others test items were only assessed max power level.

5.2. 99% Occupied Bandwidth Measurement

5.2.1. Test Limit

The operating bandwidth shall not exceed 200 kHz.

5.2.2. Test Procedure

ANSI C63.10-2013 - Section 6.9.3

5.2.3. Test Setting

1. The frequency span for the spectrum analyzer shall be between 1.5 times and 5.0 times the OBW.
2. Set RBW \geq 1% to 5% of the OBW
3. VBW = Approximately three times RBW
4. Detector = Peak
5. Trace mode = Max hold
6. Sweep = Auto couple
7. Allow the trace to stabilize
8. Use the 99% power bandwidth function of the instrument and report the measured bandwidth.

5.2.4. Test Setup

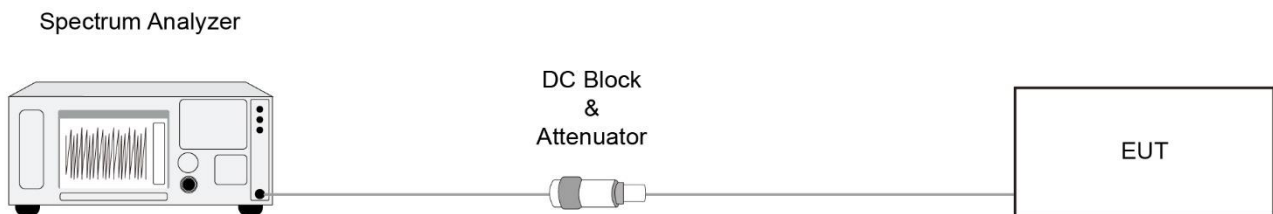

5.2.5. Test Result

Refer to Appendix A.1.

5.3. Frequency Tolerance Measurement

5.3.1. Test Limit

The frequency tolerance of the carrier signal shall be maintained within $\pm 0.005\%$ of the operating frequency over a temperature variation of -20 degrees to +50 degrees C at normal supply voltage, and for a variation in the primary supply voltage from 85% to 115% of the rated supply voltage at a temperature of 20 degrees C. Battery operated equipment shall be tested using a new battery.

5.3.2. Test Procedure

ANSI C63.10-2013 - Section 6.8

5.3.3. Test Setting

The EUT was programmed to transmit with an unmodulated carrier.

Frequency Stability Under Temperature Variations:

The equipment under test was connected to an external DC power supply and input rated voltage. RF output was connected to a frequency counter or spectrum analyzer via feed through attenuators. The EUT was placed inside the temperature chamber. Set the spectrum analyzer RBW low enough to obtain the desired frequency resolution and measure EUT 20°C operating frequency as reference frequency. While maintaining a constant temperature inside the environmental chamber, turn the EUT on and record the operating frequency at startup, and at 2 minutes, 5 minutes, and 10 minutes after the EUT is energized. Four measurements in total are made. Repeat step measure with 10°C decreased per stage until the lowest temperature reached.

Frequency Stability Under Voltage Variations:

Set chamber temperature to 20°C. Use a variable DC power source to power the EUT and set the voltage to rated voltage. Set the spectrum analyzer RBW low enough to obtain the desired frequency resolution and recorded the frequency.

Reduce the input voltage to specify extreme voltage variation ($\pm 15\%$) and endpoint, record the maximum frequency change.

5.3.4. Test Setup

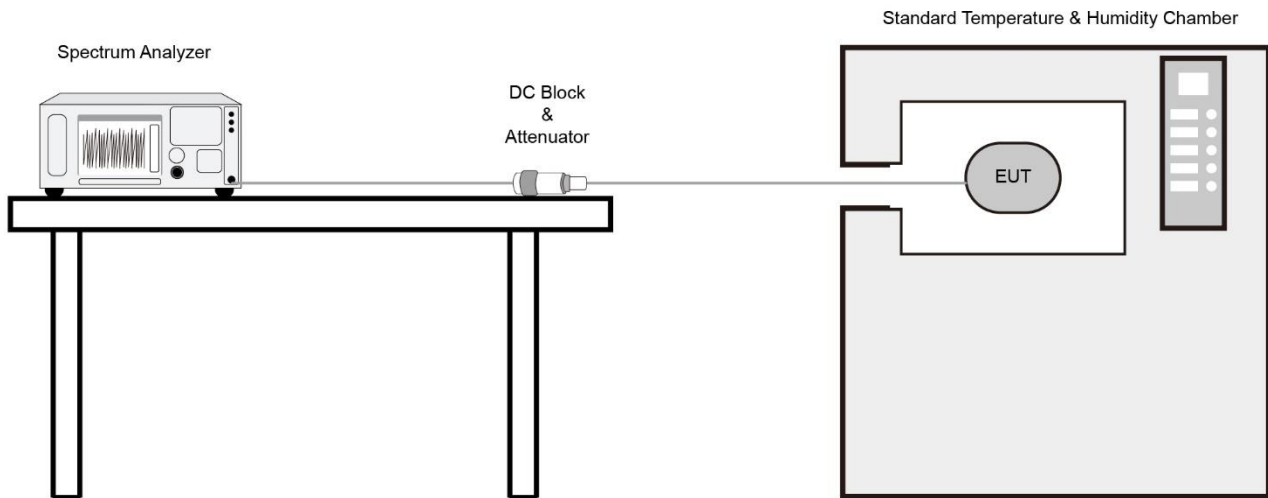

5.3.5. Test Result

Refer to Appendix A.2.

5.4. Necessary Bandwidth Measurement

5.4.1. Test Limit

According to EN 300 422-1 V1.4.2 clause 8.3.2.2, the transmitter output spectrum shall be within the mask defined as below figure.

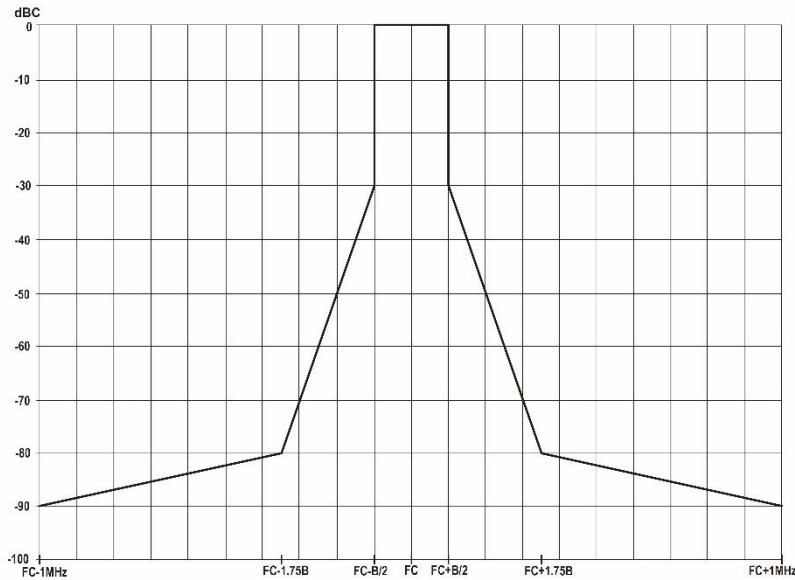

5.4.2. Test Procedure

ETSI EN 300 422-1 V1.4.2 clause 8.3.2.1.

5.4.3. Test Setting

The EUT was powered up and the transmit frequency & power output of the EUT were selected.

The spectrum analyzer center frequency is set to the nominal EUT channel center frequency.

Only bottom and top channel is required, at an output power level of 2mW & 10mW & 35mW.

5.4.4. Test Setup

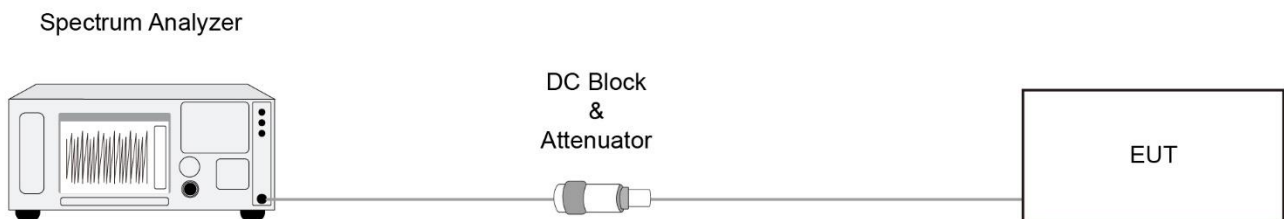

5.4.5. Test Result

Refer to Appendix A.3.

5.5. Output Power Measurement

5.5.1. Test Limit

In the bands allocated and assigned for broadcast television and in the 600 MHz service band: 50 mW EIRP.

In the 600 MHz guard band and the 600 MHz duplex gap: 20 mW EIRP.

5.5.2. Test Procedure

ANSI C63.10 - 2013 - Section 11.9.2.3.2

5.5.3. Test Setting

Average power measurements were performed only when the EUT was transmitting at its maximum power control level using a broadband power meter with a pulse sensor. The power meter implemented triggering and gating capabilities which were set up such that power measurements were recorded only during the ON time of the transmitter.

5.5.4. Test Setup

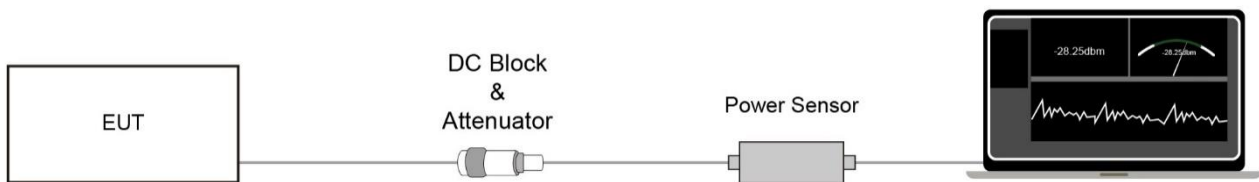

5.5.5. Test Result

Refer to Appendix A.4.

5.6. Radiated Spurious Emission Measurement

5.6.1. Test Limit

According to FCC Part 15.236(g), emissions outside of this band shall comply with the limits specified in section 8.4.3 of ETSI EN 300 422-1 V1.4.2.

State	Frequency		
	47MHz to 74MHz, 87.5MHz to 137MHz 174MHz to 230MHz, 470MHz to 862MHz	Other Frequencies below 1000MHz	Frequencies above 1000MHz
Operation	4nW	250nW	1uW
Standby	2nW	2nW	20nW

5.6.2. Test Procedure

ETSI EN 300 422-1 V1.4.2 clause 8.4.2.

5.6.3. Test Setting

Table 1 - RBW as a function of frequency

Frequency	RBW
25 ~ 30 MHz	9 kHz
30 ~ 1000 MHz	100 kHz
1000 ~ 6000 MHz	1 MHz

Emissions shall be investigated up to the 10th harmonic of the fundamental.

All the emissions shall be demonstrated using a QP detector below 1 GHz and an RMS Average detector above 1 GHz.

All significant broadband and narrowband signals found in the preliminary sweeps were measured using a peak detector at a test distance of 3 meters.

at each frequency at which a component is detected, the sample shall be rotated to obtain maximum response and the effective radiated power of that component determined by a substitution measurement.

5.6.4. Test Setup

Below 1GHz Test Setup:

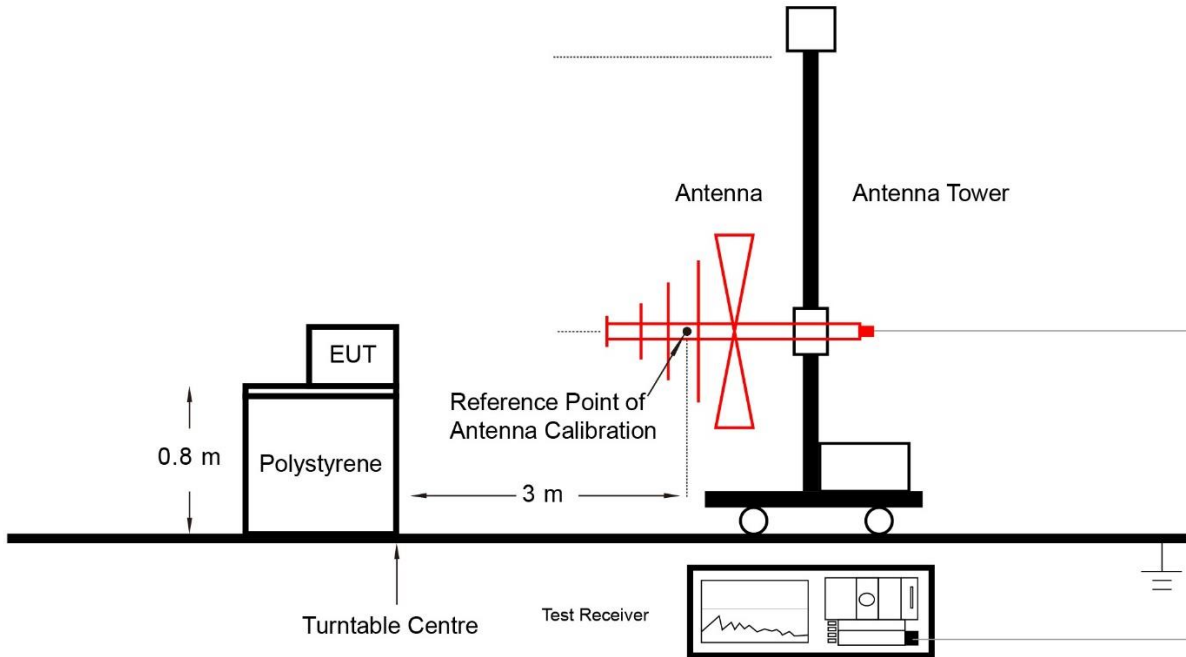

Above 1GHz Test Setup:

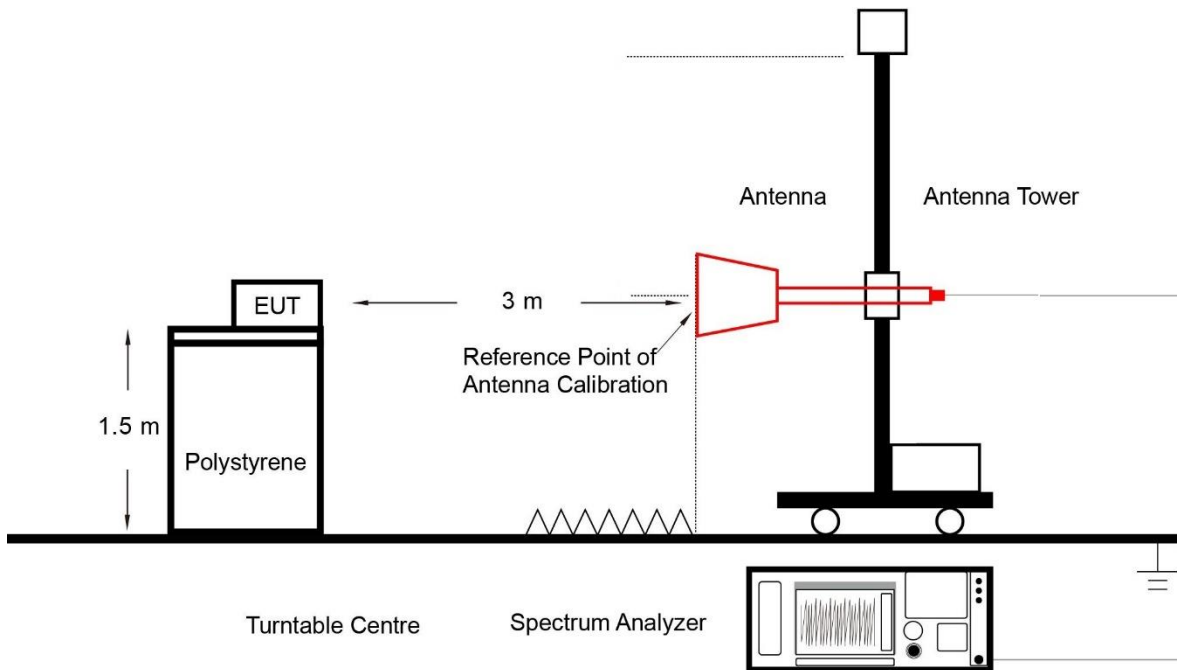

5.6.5. Test Result

Refer to Appendix A.5.

5.7. AC Conducted Emissions Measurement

5.7.1. Test Limit

FCC Part 15 Subpart C Paragraph 15.207 Limits		
Frequency (MHz)	QP (dB μ V)	Average (dB μ V)
0.15 - 0.50	66 - 56	56 - 46
0.50 - 5.0	56	46
5.0 - 30	60	50

Note 1: The lower limit shall apply at the transition frequencies.

Note 2: The limit decreases linearly with the logarithm of the frequency in the range 0.15MHz to 0.5MHz.

5.7.2. Test Setup

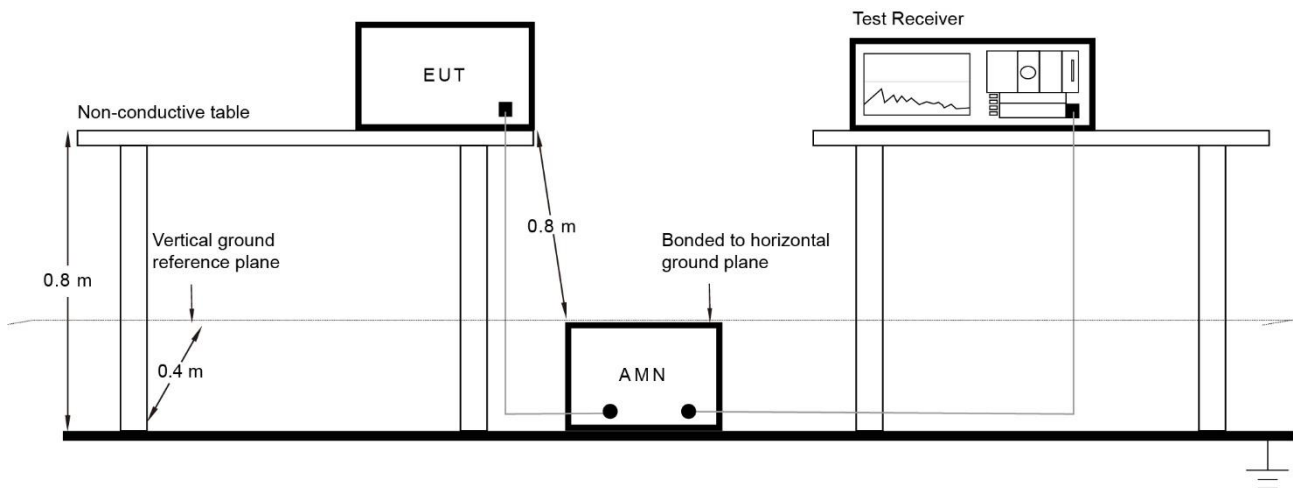

5.7.3. Test Result

Refer to Appendix A.6.

Appendix A – Test Result

A.1 99% Occupied Bandwidth Test Result

Test Site	WZ-SR5	Test Engineer	Dandy Li
Test Date	2023-04-20		

Mode	Frequency (MHz)	99% Bandwidth (kHz)	Limit (kHz)	Result
30mW Power Level	514.000	166.89	< 200	Pass
	536.000	166.52	< 200	Pass
	558.000	167.19	< 200	Pass

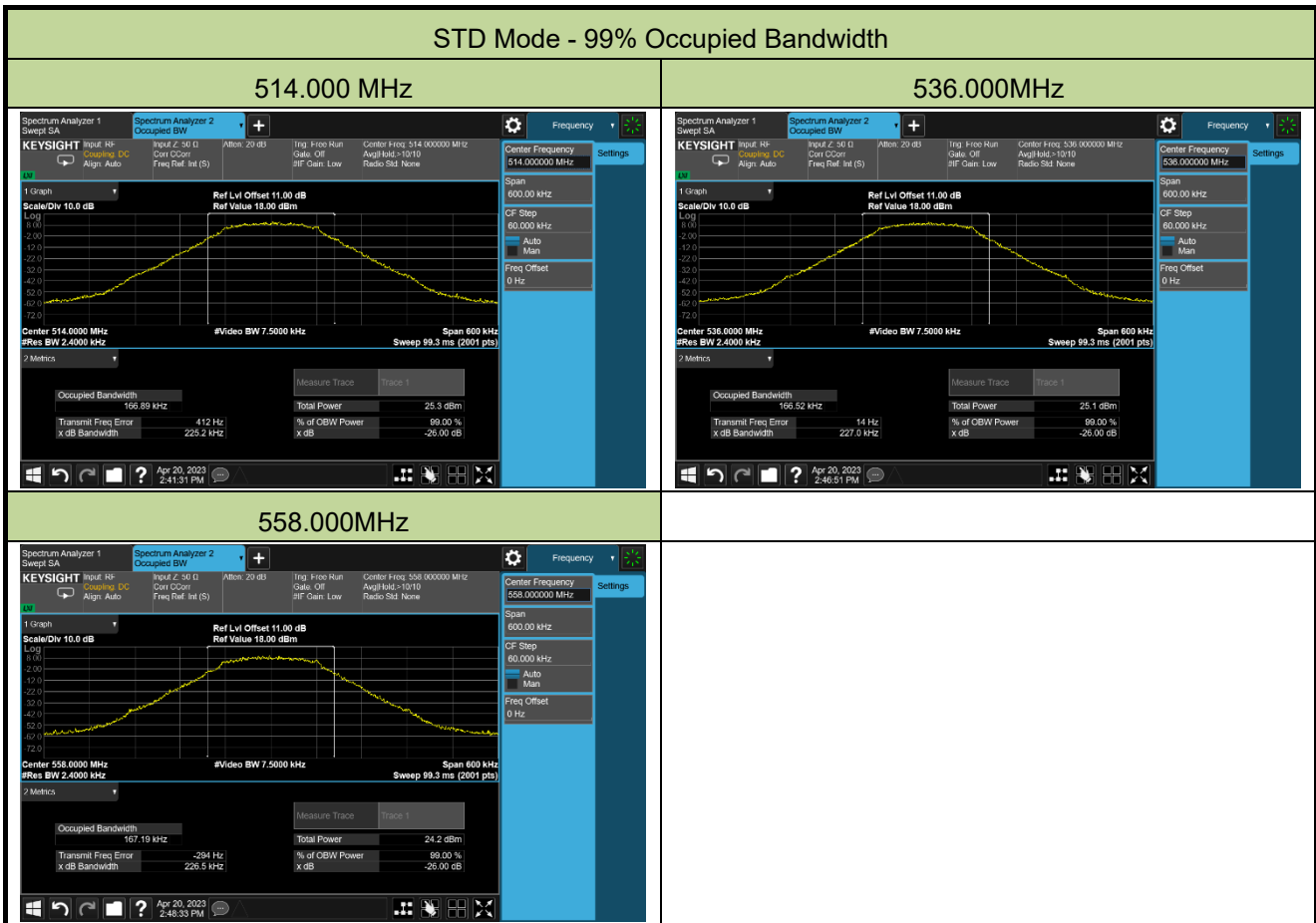

A.2 Frequency Tolerance Test Result

Test Site	WZ-TR3	Test Engineer	Dandy Li
Test Date	2023-04-23	Test Mode	514.000MHz

Voltage (%)	Power (DC)	Temp (°C)	Frequency Tolerance (%)			
			0 minutes	2 minutes	5 minutes	10 minutes
100	3.6	- 10	c	-0.000040	-0.000039	-0.000037
		0	-0.000034	-0.000033	-0.000032	-0.000032
		+ 10	-0.000024	-0.000024	-0.000023	-0.000022
		+ 20	-0.000022	-0.000019	-0.000018	-0.000017
		+ 30	-0.000020	-0.000021	-0.000020	-0.000019
		+ 40	-0.000012	-0.000011	-0.000011	-0.000011
		+ 50	0.000001	-0.000002	-0.000002	-0.000002
115	4.14	+ 20	-0.000022	-0.000019	-0.000018	-0.000017
85	3.06	+ 20	-0.000022	-0.000019	-0.000018	-0.000017

Note: Frequency Tolerance (ppm) = $\{[\text{Measured Frequency (Hz)} - \text{Declared Frequency (Hz)}] / \text{Declared Frequency (Hz)}\} * 10^2$.

A.3 Necessary Bandwidth Test Result

Test Site	WZ-SR5	Test Engineer	Dandy Li
Test Date	2023-04-20		

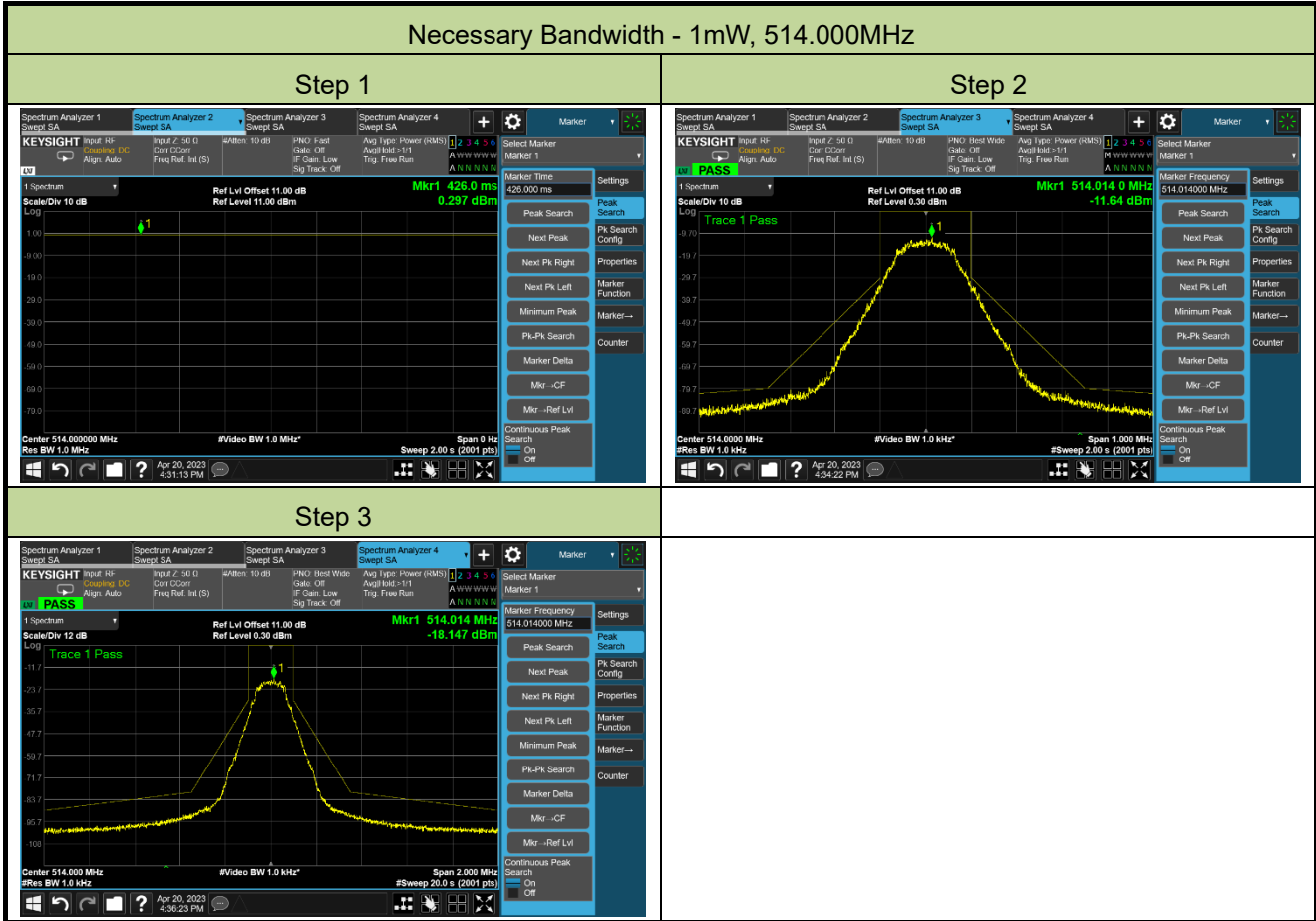

Necessary Bandwidth - 1mW, 536.000MHz

Step 1

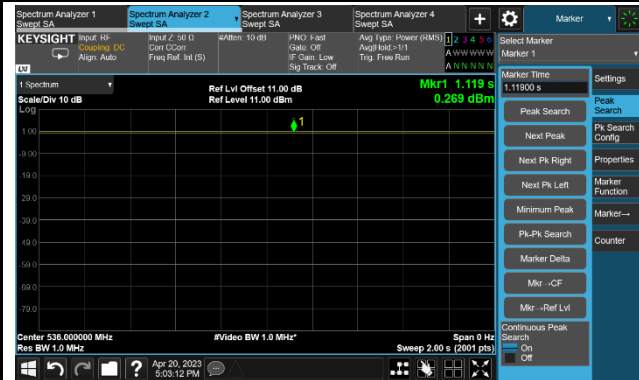

Step 2

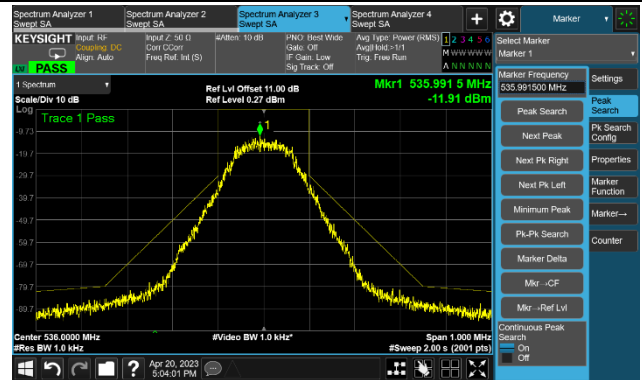

Step 3

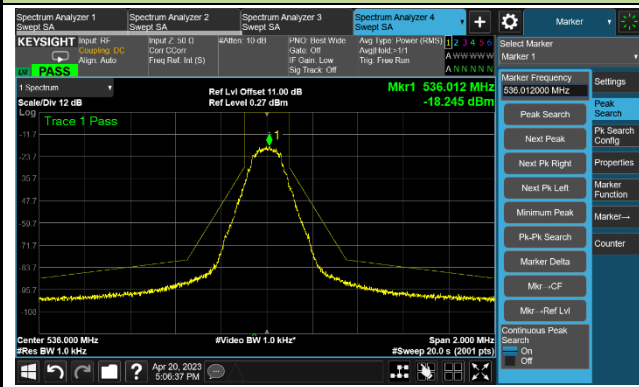

Necessary Bandwidth - 1mW, 558.000MHz

Step 1

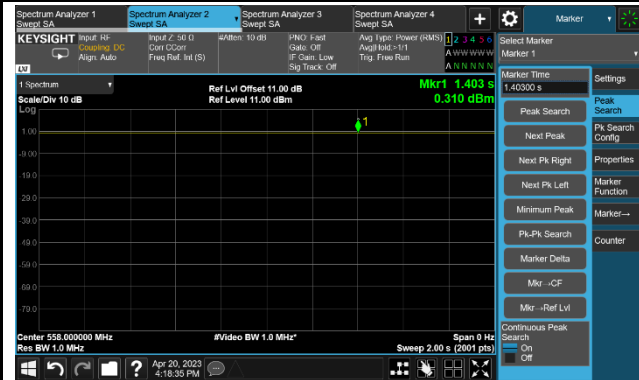

Step 2

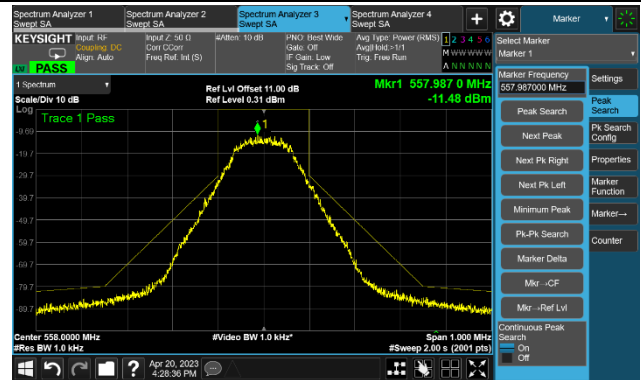

Step 3

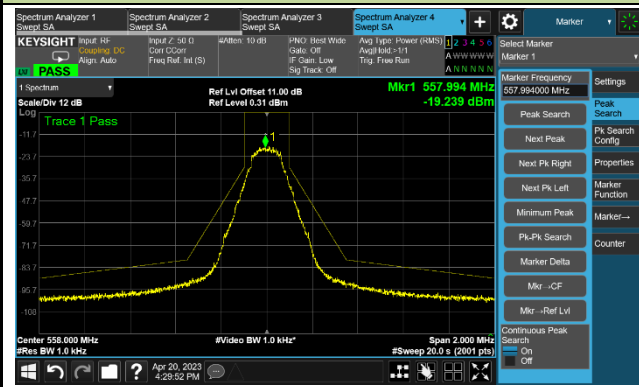

Necessary Bandwidth - 10mW, 514.000MHz

Step 1

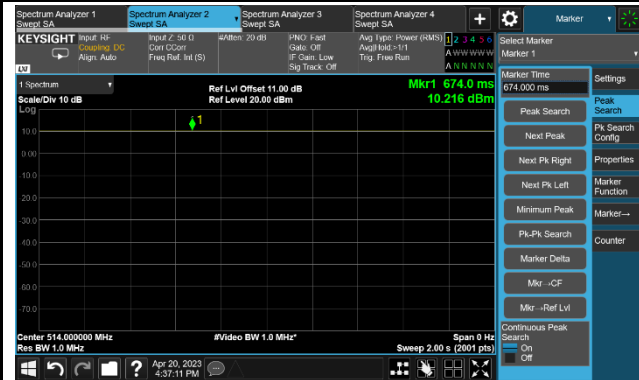

Step 2

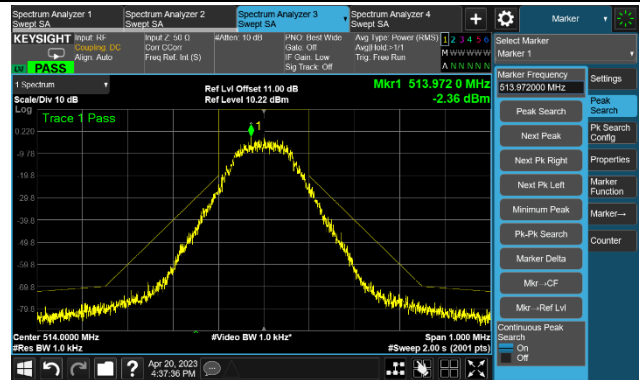

Step 3

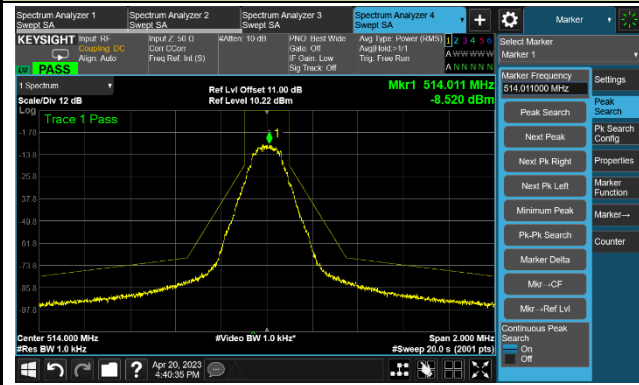

Necessary Bandwidth - 10mW, 536.000MHz

Step 1

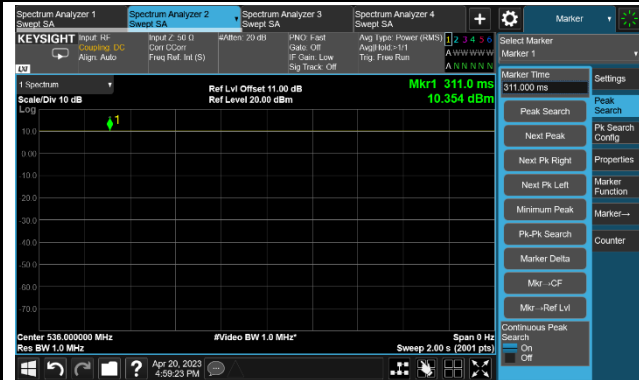

Step 2

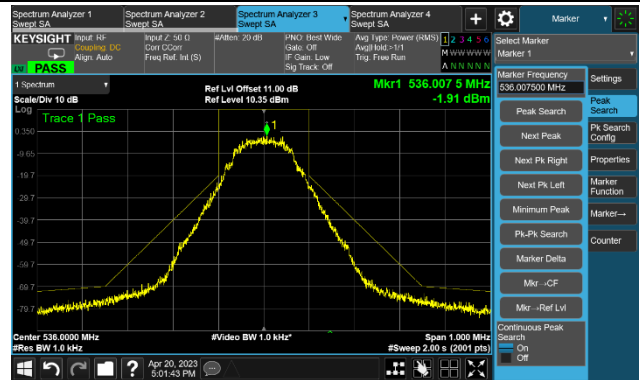

Step 3

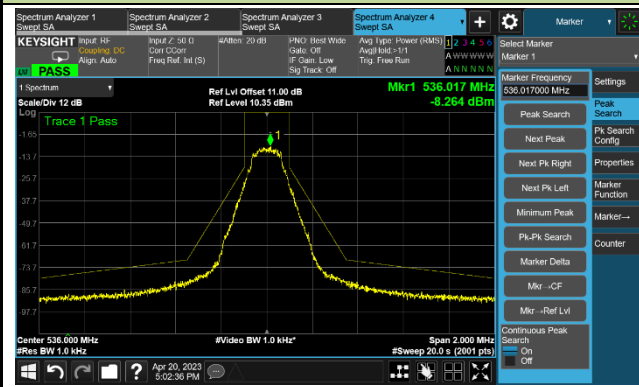

Necessary Bandwidth - 10mW, 558.000MHz

Step 1

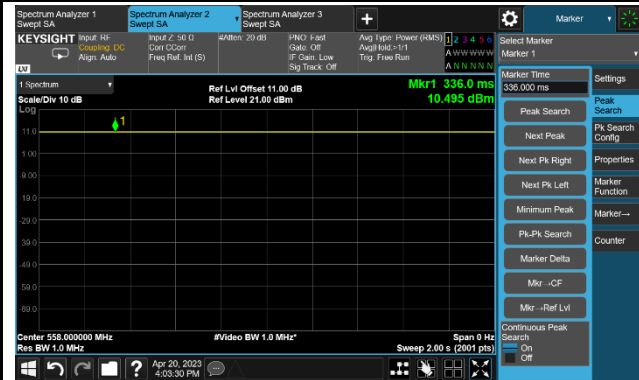

Step 2

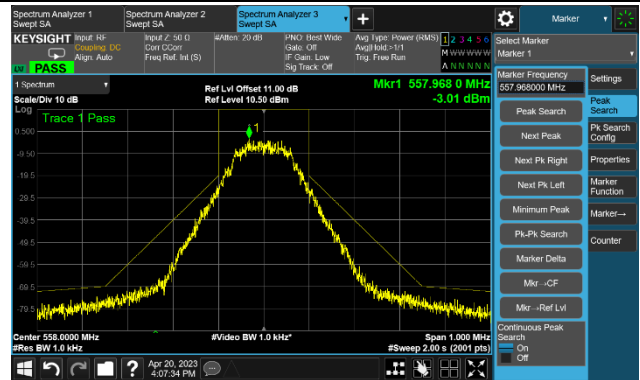

Step 3

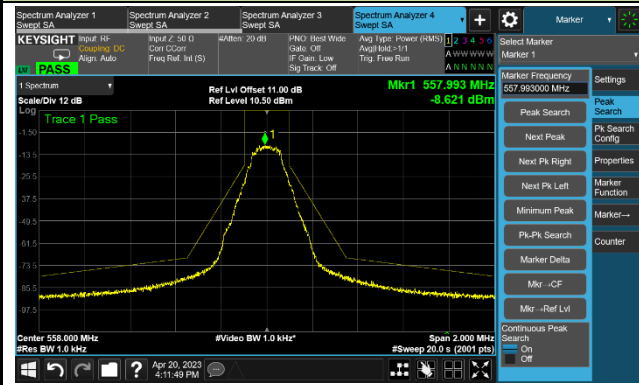

Necessary Bandwidth - 30mW, 514.000MHz

Step 1

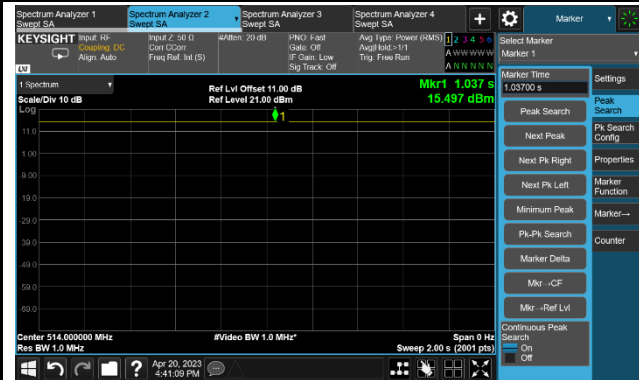

Step 2

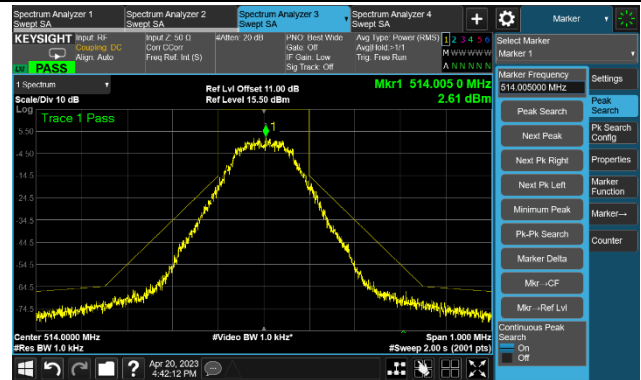

Step 3

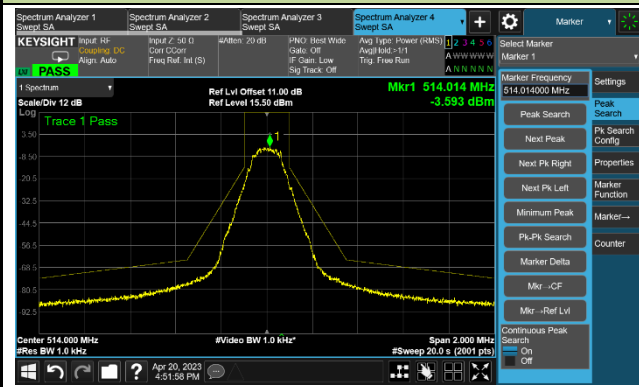

Necessary Bandwidth - 30mW, 536.000MHz

Step 1

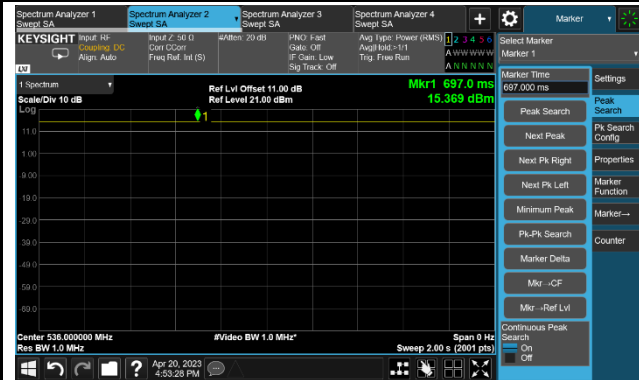

Step 2

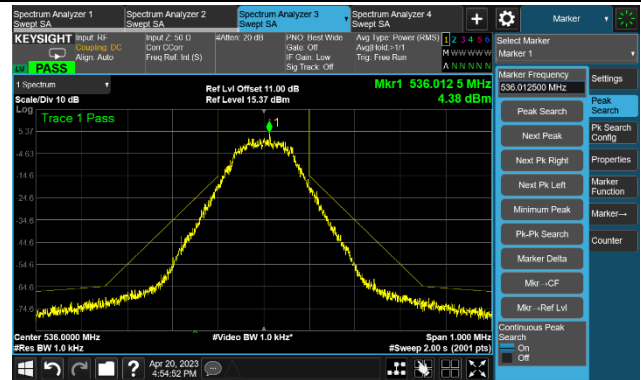

Step 3

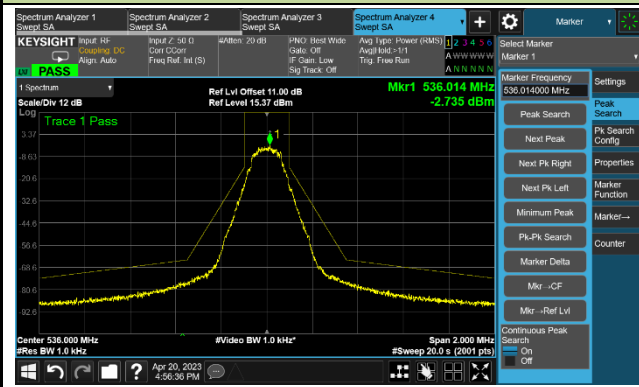

Necessary Bandwidth - 30mW, 558.000MHz

Step 1

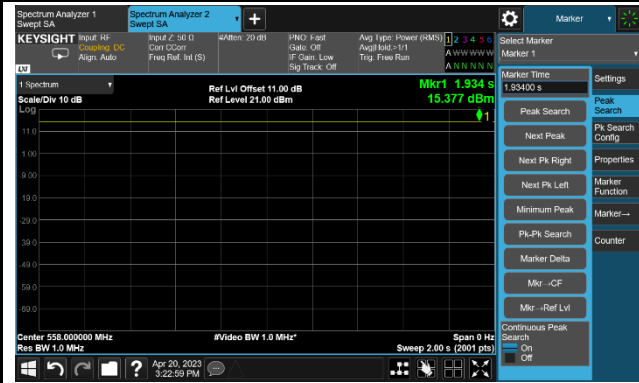

Step 2

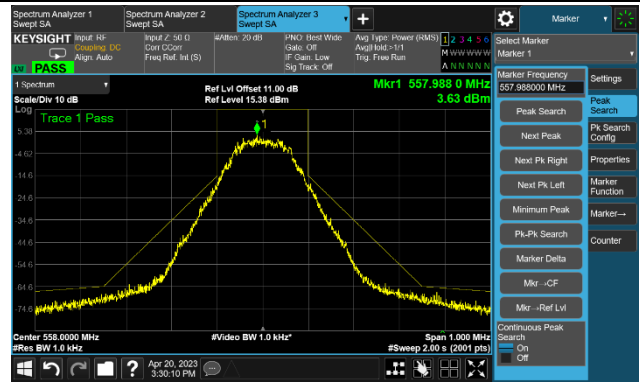

Step 3

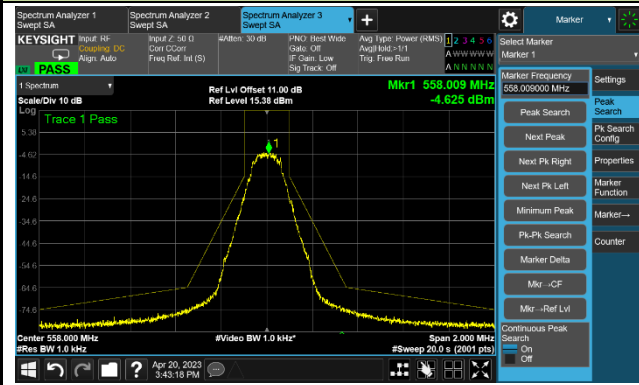

A.4 Output Power Test Result

Test Site	WZ-SR5	Test Engineer	Dandy Li
Test Date	2023-04-23		

Frequency (MHz)	Conducted Power (dBm)	Antenna Gain (dBi)	EIRP (dBm)	Limit (dBm)	Test Result
STD Mode (30mW)					
514.000	15.49	0.70	16.19	16.99	Pass
536.000	15.34	0.70	16.04	16.99	Pass
558.000	15.31	0.70	16.01	16.99	Pass
STD Mode (10mW)					
514.000	10.24	0.70	10.94	16.99	Pass
536.000	10.29	0.70	10.99	16.99	Pass
558.000	10.43	0.70	11.13	16.99	Pass
STD Mode (1mW)					
514.000	0.46	0.70	1.16	16.99	Pass
536.000	0.39	0.70	1.09	16.99	Pass
558.000	0.44	0.70	1.14	16.99	Pass

Note 1: Limit = $10 \cdot \log(50\text{mW}) = 16.99$ dBm.

Note 2: EIRP (dBm) = Conducted Power (dBm) + Antenna Gain (dBi).

A.5 Radiated Spurious Emission Test Result

Test Site	WZ-AC2	Test Engineer	Dick Shen
Test Date	2023-04-26	Test Mode	STD Mode - 30mW

Test Channel (MHz)	Frequency (MHz)	Reading Level (dBm)	Substitution Factor (dB)	Measure Level (dBm)	Limit (dBm)	Margin (dB)	Detector	Polarization
514.000	55.705	-92.9	29.3	-63.6	-54.0	-9.6	Peak	Horizontal
	728.400	-103.7	38.1	-65.6	-54.0	-11.6	Peak	Horizontal
	98.385	-105.0	40.2	-64.8	-54.0	-10.8	Peak	Vertical
	759.440	-103.5	38.5	-65.0	-54.0	-11.0	Peak	Vertical
	1365.000	-67.0	9.3	-57.7	-30.0	-27.7	Peak	Horizontal
	2440.000	-66.2	10.0	-56.2	-30.0	-26.2	Peak	Horizontal
	1360.000	-66.2	9.1	-57.1	-30.0	-27.1	Peak	Vertical
	2432.500	-65.2	9.8	-55.4	-30.0	-25.4	Peak	Vertical
536.000	52.795	-104.7	30.7	-74.0	-54.0	-20.0	Peak	Horizontal
	724.520	-102.9	38.1	-64.8	-54.0	-10.8	Peak	Horizontal
	96.445	-104.1	40.0	-64.1	-54.0	-10.1	Peak	Vertical
	777.870	-103.0	38.2	-64.8	-54.0	-10.8	Peak	Vertical
	1365.000	-66.8	9.3	-57.5	-30.0	-27.5	Peak	Horizontal
	4670.000	-70.0	14.7	-55.3	-30.0	-25.3	Peak	Horizontal
	1360.000	-67.3	9.1	-58.2	-30.0	-28.2	Peak	Vertical
	2822.500	-67.0	10.6	-56.4	-30.0	-26.4	Peak	Vertical
558.000	49.400	-104.0	31.8	-72.2	-54.0	-18.2	Peak	Horizontal
	706.090	-103.6	37.6	-66.0	-54.0	-12.0	Peak	Horizontal
	102.750	-103.6	38.7	-64.9	-54.0	-10.9	Peak	Vertical
	761.380	-103.7	38.5	-65.2	-54.0	-11.2	Peak	Vertical
	1250.000	-67.7	8.8	-58.9	-30.0	-28.9	Peak	Horizontal
	3107.500	-67.4	10.5	-56.9	-30.0	-26.9	Peak	Horizontal
	1920.000	-65.4	8.0	-57.4	-30.0	-27.4	Peak	Vertical
	2820.000	-67.3	10.6	-56.7	-30.0	-26.7	Peak	Vertical

Note 1: Measure Level (dBm) = Reading Level (dBm) + Substitution Factor (dB)

Note 2: Substitution Factor (dB) = Cable Loss (dB) + Space Attenuation (dB) - Antenna Gain (dBi) - 2.15 (dB)

Note 3: QP measurement was not performed when peak measure level was lower than the QP limit.

RMS measurement was not performed when peak measure level was lower than the RMS limit.

A.6 AC Conducted Emissions Test Result

Site: WZ-SR2	Test Date: 2023-05-04
Limit: FCC_Part15.107_CE_AC Power_Class B	Engineer: Alin Zhou
Probe: ENV216_101683_Filter Off_E	Polarity: Line
EUT: Plug-on Wireless Transmitter	Power: AC 120V/60Hz
Note: Transmit at channel 514.000MHz	

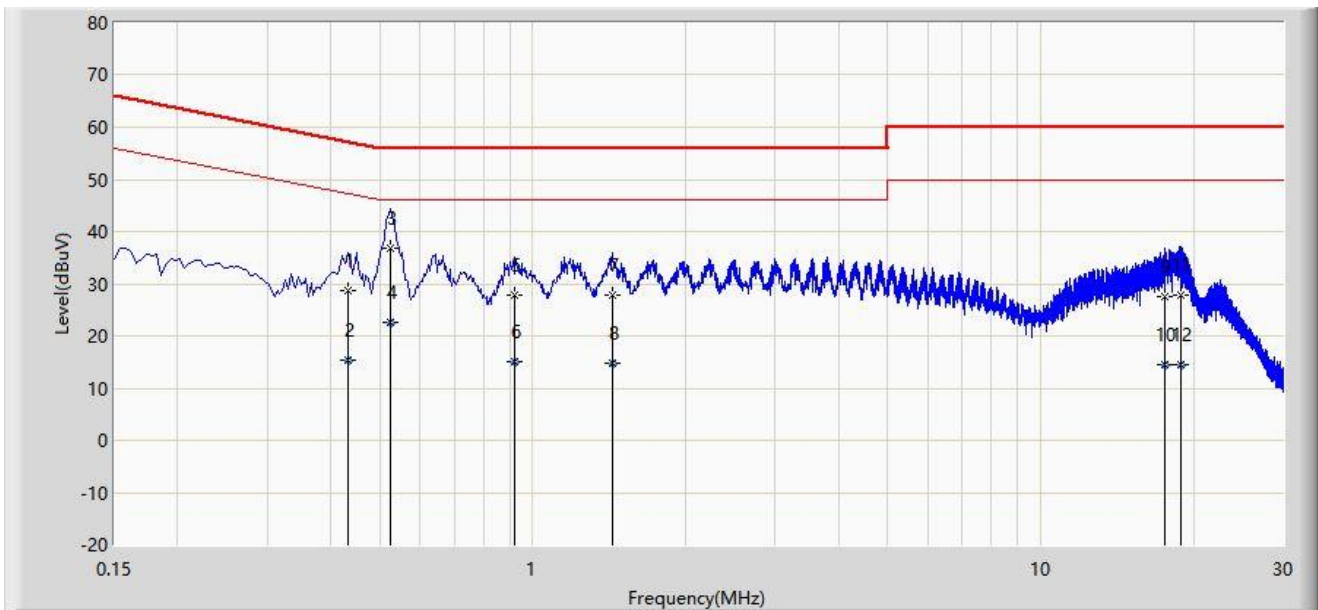

No	Mark	Frequency (MHz)	Measure Level (dBμV)	Reading Level (dBμV)	Margin (dB)	Limit (dBμV)	Factor (dB)	Type
1		0.434	28.773	18.933	-28.402	57.176	9.840	QP
2		0.434	15.316	5.476	-31.860	47.176	9.840	AV
3	*	0.526	36.872	26.980	-19.128	56.000	9.892	QP
4		0.526	22.579	12.687	-23.421	46.000	9.892	AV
5		0.918	27.915	17.838	-28.085	56.000	10.077	QP
6		0.918	15.074	4.997	-30.926	46.000	10.077	AV
7		1.434	27.750	17.616	-28.250	56.000	10.135	QP
8		1.434	14.754	4.620	-31.246	46.000	10.135	AV
9		17.522	27.548	16.346	-32.452	60.000	11.203	QP
10		17.522	14.378	3.175	-35.622	50.000	11.203	AV
11		18.930	27.896	16.536	-32.104	60.000	11.361	QP
12		18.930	14.577	3.216	-35.423	50.000	11.361	AV

Note 1: " * ", means this data is the worst emission level.

Note 2: Measure Level (dBμV) = Reading Level (dBμV) + Factor (dB).

Note 3: Factor (dB) = Cable Loss (dB) + LISN Factor (dB).

Site: WZ-SR2	Test Date: 2023-05-04
Limit: FCC_Part15.107_CE_AC Power_Class B	Engineer: Alin Zhou
Probe: ENV216_101683_Filter Off_E	Polarity: Neutral
EUT: Plug-on Wireless Transmitter	Power: AC 120V/60Hz
Note: Transmit at channel 514.000MHz	

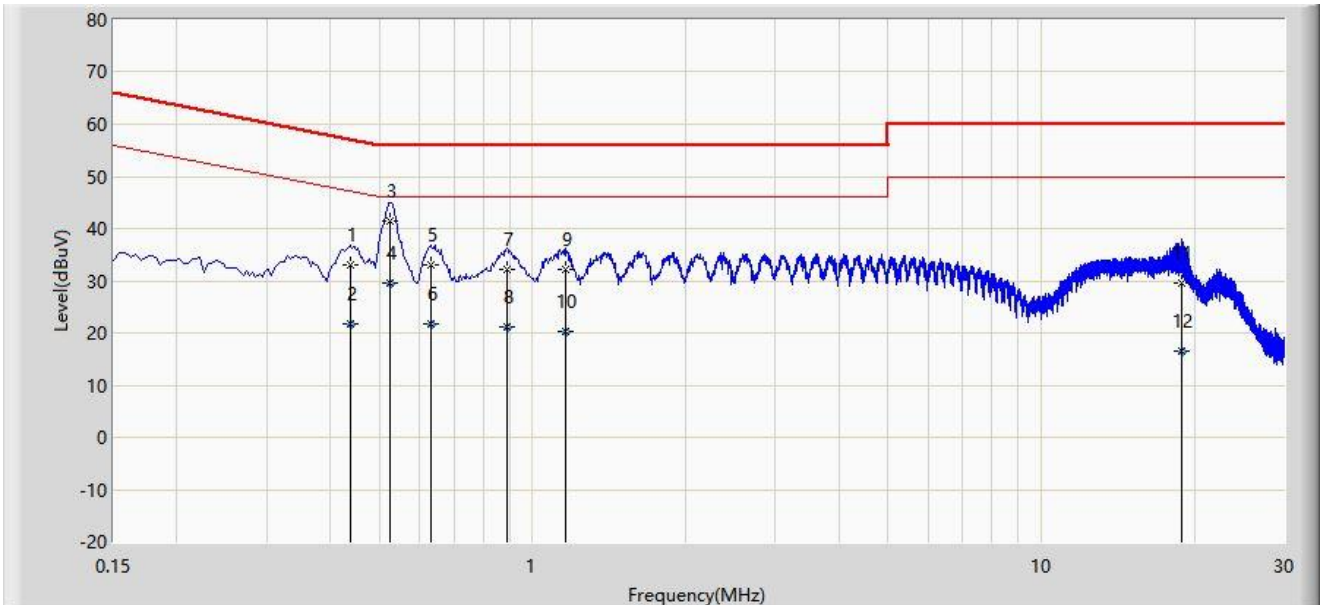

No	Mark	Frequency (MHz)	Measure Level (dBµV)	Reading Level (dBµV)	Margin (dB)	Limit (dBµV)	Factor (dB)	Type
1		0.438	32.978	23.121	-24.121	57.100	9.857	QP
2		0.438	21.747	11.889	-25.353	47.100	9.857	AV
3	*	0.526	41.434	31.529	-14.566	56.000	9.904	QP
4		0.526	29.573	19.668	-16.427	46.000	9.904	AV
5		0.630	32.969	23.011	-23.031	56.000	9.957	QP
6		0.630	21.812	11.855	-24.188	46.000	9.957	AV
7		0.890	32.288	22.202	-23.712	56.000	10.086	QP
8		0.890	21.255	11.169	-24.745	46.000	10.086	AV
9		1.158	32.062	21.917	-23.938	56.000	10.145	QP
10		1.158	20.410	10.265	-25.590	46.000	10.145	AV
11		18.838	29.611	18.236	-30.389	60.000	11.376	QP
12		18.838	16.601	5.226	-33.399	50.000	11.376	AV

Note 1: " * ", means this data is the worst emission level.

Note 2: Measure Level (dBµV) = Reading Level (dBµV) + Factor (dB).

Note 3: Factor (dB) = Cable Loss (dB) + LISN Factor (dB).

Appendix B - Test Setup Photograph

Refer to "2304RSU032-UT" file.

Appendix C - EUT Photograph

Refer to "2304RSU032-UE" file.