

MEASUREMENT REPORT

FCC PART 15.407

FCC ID: DD4GLXD6Z3

Applicant: Shure Incorporated

Product: Wireless Guitar Pedal Receiver

Model No.: GLXD6+ Z3

Trademark: 

FCC Classification: Unlicensed National Information Infrastructure (UNII)

FCC Rule Part(s): Part15 Subpart E (Section 15.407)

Test Result: Complies

Test Date: July 23 ~ August 18, 2021

Reviewed By:



Jame Yuan

Approved By:

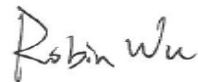

Robin Wu



The test results relate only to the samples tested.

This equipment has been shown to be capable of compliance with the applicable technical standards as indicated in the measurement report and was tested in accordance with the measurement procedures specified in KDB 789033 D02v02r01. Test results reported herein relate only to the item(s) tested.

The test report shall not be reproduced except in full without the written approval of MRT Technology (Suzhou) Co., Ltd.

Revision History

Report No.	Version	Description	Issue Date	Note
2107RSU040-U2	Rev. 01	Initial Report	08-21-2021	Valid

CONTENTS

Description	Page
1. General Information	5
1.1. Applicant	5
1.2. Manufacturer	5
1.3. Testing Facility	5
1.4. Product Information	6
1.5. Radio Specification under Test	6
1.6. Test Frequencies	7
1.7. Antennas Details	7
2. Test Configuration	8
2.1. Test Mode	8
2.2. Test Setup and Software	8
2.3. Duty Cycle	9
2.4. Applicable Standards	9
2.5. Test Environment Condition	9
3. Antenna Requirements	10
4. Test Equipment Calibration Date	11
5. Measurement Uncertainty	14
6. Test Result	15
6.1. Summary	15
6.2. Emission Bandwidth Measurement	16
6.2.1. Test Limit	16
6.2.2. Test Procedure Used	16
6.2.3. Test Setting	16
6.2.4. Test Setup	16
6.2.5. Test Result	17
6.3. 6dB Bandwidth Measurement	19
6.3.1. Test Limit	19
6.3.2. Test Procedure Used	19
6.3.3. Test Setting	19
6.3.4. Test Setup	19
6.3.5. Test Result	20
6.4. Output Power Measurement	22
6.4.1. Test Limit	22
6.4.2. Test Procedure Used	22

6.4.3. Test Setting	22
6.4.4. Test Setup	22
6.4.5. Test Result	23
6.5. Power Spectral Density Measurement.....	24
6.5.1. Test Limit	24
6.5.2. Test Procedure Used	24
6.5.3. Test Setting	24
6.5.4. Test Setup	25
6.5.5. Test Result	26
6.6. Frequency Stability Measurement	28
6.6.1. Test Limit	28
6.6.2. Test Procedure Used	28
6.6.3. Test Setup	29
6.6.4. Test Result	30
6.7. Radiated Spurious Emission Measurement	31
6.7.1. Test Limit	31
6.7.2. Test Procedure Used	31
6.7.3. Test Setting	31
6.7.4. Test Setup	33
6.7.5. Test Result	34
6.8. Radiated Restricted Band Edge Measurement.....	42
6.8.1. Test Limit	42
6.8.2. Test Procedure Used	43
6.8.3. Test Setting	43
6.8.4. Test Setup	44
6.8.5. Test Result	45
6.9. AC Conducted Emissions Measurement	53
6.9.1. Test Limit	53
6.9.2. Test Setup	53
6.9.3. Test Result	54
7. Conclusion.....	56
Appendix A - Test Setup Photograph	57
Appendix B - EUT Photograph.....	58

1. General Information

1.1. Applicant

Shure Incorporated
 5800 West Touhy Avenue, Niles, IL 60714-4608, USA

1.2. Manufacturer

Shure Incorporated
 5800 West Touhy Avenue, Niles, IL 60714-4608, USA

1.3. Testing Facility

<input checked="" type="checkbox"/>	<p>Test Site – MRT Suzhou Laboratory</p> <hr/> <p>Laboratory Location (Suzhou - Wuzhong) D8 Building, No.2 Tian'edang Rd., Wuzhong Economic Development Zone, Suzhou, China</p> <p>Laboratory Location (Suzhou - SIP) 4b Building, Liando U Valley, No.200 Xingpu Rd., Shengpu Town, Suzhou Industrial Park, China</p> <hr/> <p>Laboratory Accreditations</p> <p>A2LA: 3628.01 CNAS: L10551 FCC: CN1166 ISED: CN0001</p> <p>VCCI: <input type="checkbox"/>R-20025 <input type="checkbox"/>G-20034 <input type="checkbox"/>C-20020 <input type="checkbox"/>T-20020 <input type="checkbox"/>R-20141 <input type="checkbox"/>G-20134 <input type="checkbox"/>C-20103 <input type="checkbox"/>T-20104</p>
<input type="checkbox"/>	<p>Test Site – MRT Shenzhen Laboratory</p> <hr/> <p>Laboratory Location (Shenzhen) 1G, Building A, Junxiangda Building, Zhongshanyuan Road West, Nanshan District, Shenzhen, China</p> <hr/> <p>Laboratory Accreditations</p> <p>A2LA: 3628.02 CNAS: L10551 FCC: CN1284 ISED: CN0105</p>
<input type="checkbox"/>	<p>Test Site – MRT Taiwan Laboratory</p> <hr/> <p>Laboratory Location (Taiwan) No. 38, Fuxing 2nd Rd., Guishan Dist., Taoyuan City 333, Taiwan (R.O.C.)</p> <hr/> <p>Laboratory Accreditations</p> <p>TAF: L3261-190725 FCC: 291082, TW3261 ISED: TW3261</p>

1.4. Product Information

Product Name	Wireless Guitar Pedal Receiver
Model No.	GLXD6+ Z3
Serial No.	3AE12002409
Radio Specification	2.4GHz & 5.8GHz
Antenna Specification	Refer to clause 1.7
Power Type	AC/DC Adapter
Accessories	
AC/DC Adapter	Model No.: PS24US Input: 100 ~ 240V, 50/60Hz, 0.15A Output: 12.0V=0.4A

Note: The information of EUT was provided by the manufacturer, and the accuracy of the information shall be the responsibility of the manufacturer.

1.5. Radio Specification under Test

Frequency Range	5729 ~ 5846MHz
Bandwidth Mode	Full and Half
Channel Number	55
Channel Spacing	1MHz
Type of Modulation	2-level CPM with Gaussian shaping (basically GFSK)
Antenna Number	2

Note 1: For other features of this EUT, test report will be issued separately.

Note 2: Two RF paths and antenna are the same and only one antenna can work during normal operation, it is switchable.

1.6. Test Frequencies

Operating Bands (MHz)	Test Frequency (MHz)		
	Lowest	Middle	Highest
5729 ~ 5846	5729	5788	5846

Note: Detail working frequencies refer to operation description.

1.7. Antennas Details

Antenna Type	Frequency Band (MHz)	Max Peak Gain (dBi)
PIFA Antenna	5729	3.10
	5788	4.45
	5846	4.79

2. Test Configuration

2.1. Test Mode

Test Mode	Mode 1: Transmit by Full BW
	Mode 2: Transmit by Half BW

Note: Bandwidth abbreviation is BW.

2.2. Test Setup and Software

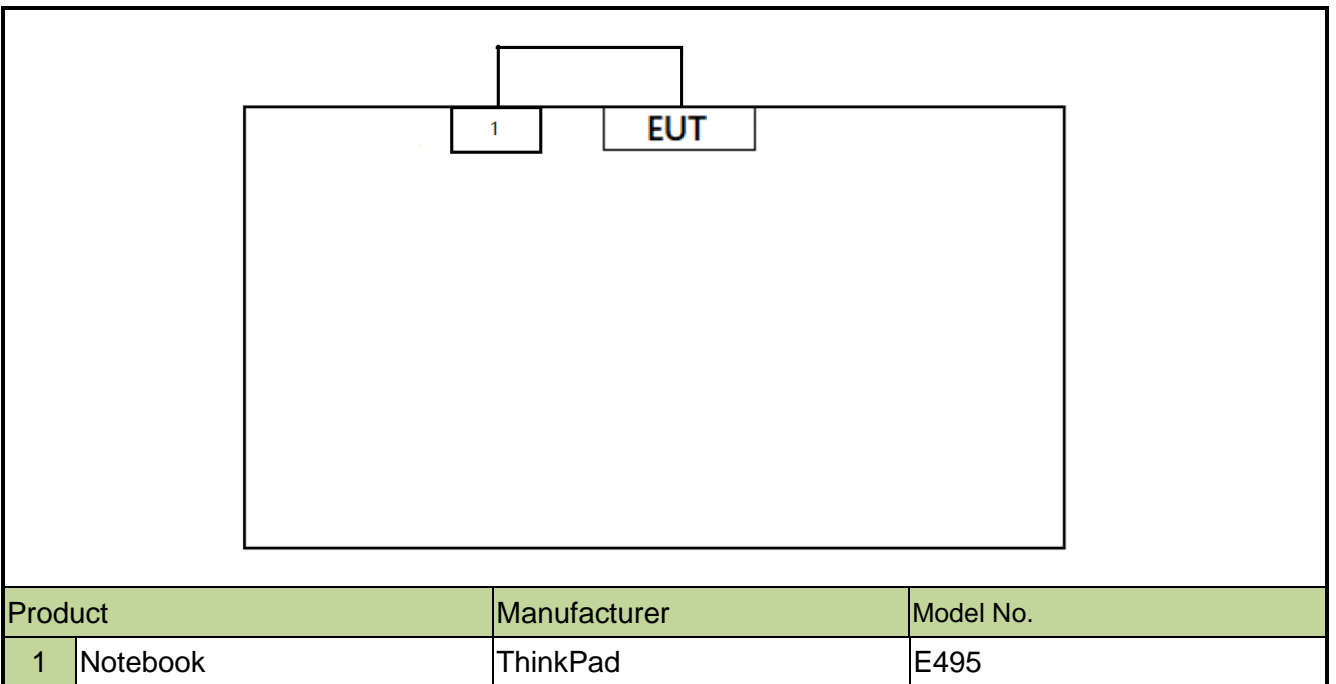

Note 1: The test utility software used during testing was “ttermpro.exe”, and the version was 4.78.

Note 2: Detail power setting refer to operation description.

2.3. Duty Cycle

The maximum achievable duty cycles for all modes were determined based on measurements performed on a spectrum analyzer in zero-span mode with RBW = 8MHz, VBW = 50MHz. The RBW and VBW were both greater than 50/T, where T is the minimum transmission duration, and the number of sweep points across T was greater than 100. The duty cycles are as follows:

Test Mode	Duty Cycle
Full BW	60.00%
Half BW	80.25%

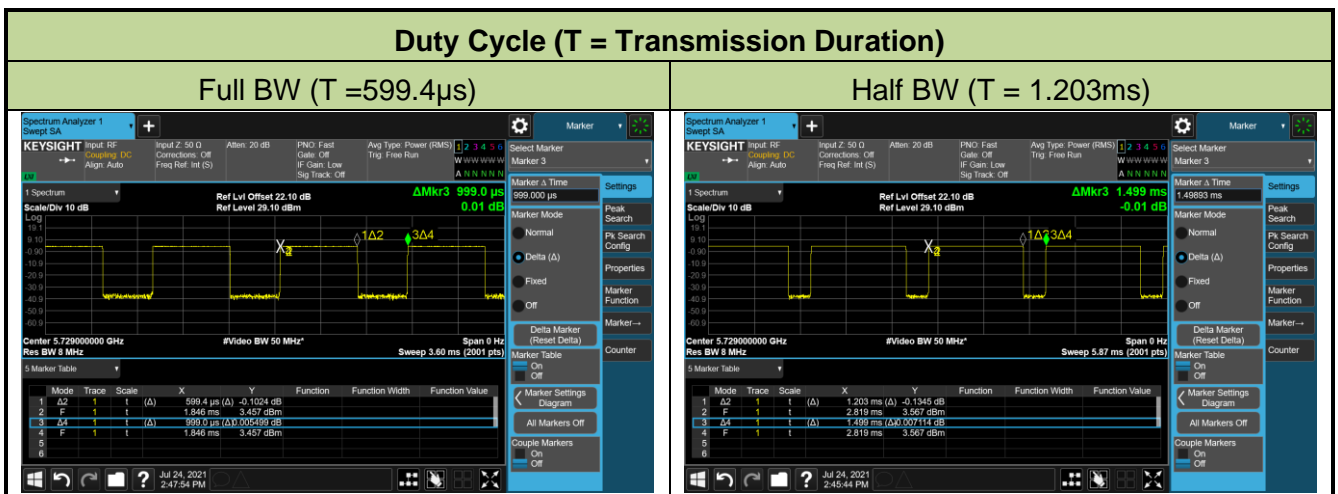

2.4. Applicable Standards

According to the specifications of the manufacturer, the EUT must comply with the requirements of the following standards:

- ANSI C63.10-2013
- FCC KDB 789033 D02v02r01

2.5. Test Environment Condition

Ambient Temperature	15 ~ 35 °C
Relative Humidity	20 ~ 75 %RH

3. Antenna Requirements

Excerpt from §15.203 of the FCC Rules/Regulations:

“An intentional radiator antenna shall be designed to ensure that no antenna other than that furnished by the responsible party can be used with the device. The use of a permanently attached antenna or of an antenna that uses a unique coupling to the intentional radiator shall be considered sufficient to comply with the provisions of this section.”

- The antenna of the device is **permanently attached**.
- There are no provisions for connection to an external antenna.

Conclusion:

The unit complies with the requirement of §15.203.

4. Test Equipment Calibration Date

Conducted Emission (WZ-SR2)

Instrument	Manufacturer	Type No.	Asset No.	Cali. Interval	Cali. Due Date
EMI Test Receiver	R&S	ESR3	MRTSUE06909	1 year	2021/11/22
Two-Line V-Network	R&S	ENV216	MRTSUE06002	1 year	2022/06/08
Thermal Hygrometer	testo	608-H1	MRTSUE06404	1 year	2022/06/28
Shielding Room	MIX-BEP	Chamber-SR2	MRTSUE06215	N/A	N/A

Conducted Emission (SIP-SR2)

Instrument	Manufacturer	Type No.	Asset No.	Cali. Interval	Cali. Due Date
EMI Test Receiver	R&S	ESR3	MRTSUE06613	1 year	2022/06/24
Two-Line V-Network	R&S	ENV216	MRTSUE06003	1 year	2022/06/08
Thermal Hygrometer	testo	608-H1	MRTSUE06621	1 year	2021/12/03

Radiated Emission (WZ-AC1)

Instrument	Manufacturer	Type No.	Asset No.	Cali. Interval	Cali. Due Date
EMI Test Receiver	R&S	ESR7	MRTSUE06001	1 year	2022/01/04
Loop Antenna	Schwarzbeck	FMZB 1519	MRTSUE06025	1 year	2021/11/08
Bilog Period Antenna	Schwarzbeck	VULB 9168	MRTSUE06172	1 year	2022/08/05
Horn Antenna	Schwarzbeck	BBHA 9120D	MRTSUE06023	1 year	2021/09/27
Horn Antenna	Schwarzbeck	BBHA9170	MRTSUE06597	1 year	2021/12/14
Microwave System Amplifier	Agilent	83017A	MRTSUE06076	1 year	2021/11/14
Preamplifier	Schwarzbeck	BBV 9721	MRTSUE06121	1 year	2022/06/09
Thermal Hygrometer	testo	608-H1	MRTSUE06403	1 year	2022/06/28
Anechoic Chamber	TDK	Chamber-AC1	MRTSUE06212	1 year	2022/04/29

Radiated Emission (WZ-AC2)

Instrument	Manufacturer	Type No.	Asset No.	Cali. Interval	Cali. Due Date
MXE EMI Receiver	Keysight	N9038A	MRTSUE06125	1 year	2022/06/24
Loop Antenna	Schwarzbeck	FMZB 1519	MRTSUE06025	1 year	2021/11/08
Bilog Period Antenna	Schwarzbeck	VULB 9162	MRTSUE06022	1 year	2022/05/24
Broad-Band Horn Antenna	Schwarzbeck	BBHA 9120D	MRTSUE06171	1 year	2021/10/25
Horn Antenna	Schwarzbeck	BBHA9170	MRTSUE06597	1 year	2021/12/14
Broadband Coaxial Preamplifier	Schwarzbeck	BBV 9718	MRTSUE06176	1 year	2021/11/14
Thermal Hygrometer	Minggao	ETH529	MRTSUE06170	1 year	2021/12/08
Anechoic Chamber	RIKEN	Chamber-AC2	MRTSUE06213	1 year	2022/04/29

Radiated Emission (SIP-AC1)

Instrument	Manufacturer	Type No.	Asset No.	Cali. Interval	Cali. Due Date
EMI Test Receiver	R&S	ESR3	MRTSUE06612	1 year	2022/06/24
EXA Signal Analyzer	Keysight	N9010B	MRTSUE06559	1 year	2022/06/24
Loop Antenna	Schwarzbeck	FMZB 1519 B	MRTSUE06937	1 year	2022/03/09
Bilog Period Antenna	Schwarzbeck	VULB9168	MRTSUE06645	1 year	2021/08/30
Double Ridged Horn Antenna	R&S	HF907	MRTSUE06610	1 year	2021/08/30
Preamplifier	EMCI	EMC051845SE	MRTSUE06600	1 year	2021/11/09
Thermal Hygrometer	testo	608-H1	MRTSUE06620	1 year	2021/12/03
Anechoic Chamber	RIKEN	SIP-AC1	MRTSUE06554	1 year	2021/12/24

Radiated Emission (SIP-AC2)

Instrument	Manufacturer	Type No.	Asset No.	Cali. Interval	Cali. Due Date
EMI Test Receiver	R&S	ESR3	MRTSUE06613	1 year	2022/06/24
MXA Signal Analyzer	Keysight	N9020B	MRTSUE06604	1 year	2021/09/26
Loop Antenna	Schwarzbeck	FMZB 1519 B	MRTSUE06937	1 year	2022/03/09
Bilog Period Antenna	Schwarzbeck	VULB9168	MRTSUE06646	1 year	2021/08/30
Horn Antenna	Schwarzbeck	BBHA9120D	MRTSUE06648	1 year	2021/11/26
Horn Antenna	Schwarzbeck	BBHA9170	MRTSUE06599	1 year	2021/11/26
Preamplifier	EMCI	EMC051845SE	MRTSUE06644	1 year	2021/11/09
Preamplifier	EMCI	EMC184045SE	MRTSUE06602	1 year	2021/10/12
Thermal Hygrometer	testo	608-H1	MRTSUE06624	1 year	2021/12/03
Anechoic Chamber	RIKEN	SIP-AC2	MRTSUE06781	1 year	2021/12/24

Radiated Emission (SIP-AC3)

Instrument	Manufacturer	Type No.	Asset No.	Cali. Interval	Cali. Due Date
Preamplifier	Schwarzbeck	BBV 9721	MRTSUE06121	1 year	2022/06/09
EMI Test Receiver	R&S	ESR3	MRTSUE06612	1 year	2022/06/24
EXA Signal Analyzer	Keysight	N9010B	MRTSUE06559	1 year	2022/06/24
Loop Antenna	Schwarzbeck	FMZB 1519	MRTSUE06025	1 year	2021/11/08
Bilog Period Antenna	Schwarzbeck	VULB9168	MRTSUE06646	1 year	2021/08/30
Double Ridged Horn Antenna	R&S	HF907	MRTSUE06611	1 year	2021/09/13
Horn Antenna	Schwarzbeck	BBHA9170	MRTSUE06598	1 year	2021/11/26
Preamplifier	EMCI	EMC012645SE	MRTSUE06642	1 year	2022/01/14
Thermal Hygrometer	testo	608-H1	MRTSUE06622	1 year	2021/12/03
Anechoic Chamber	RIKEN	SIP-AC3	MRTSUE06782	1 year	2021/12/24

Conducted Test Equipment (WZ-TR3)

Instrument	Manufacturer	Type No.	Asset No.	Cali. Interval	Cali. Due Date
EXA Signal Analyzer	Agilent	N9020A	MRTSUE06106	1 year	2022/04/13
EXA Signal Analyzer	Keysight	N9010B	MRTSUE06607	1 year	2022/01/06
Power Meter	Agilent	U2021XA	MRTSUE06030	1 year	2021/10/22
USB wideband power sensor	Keysight	U2021XA	MRTSUE06446	1 year	2022/06/08
USB wideband power sensor	Keysight	U2021XA	MRTSUE06447	1 year	2022/06/08
Bluetooth Test Set	Anritsu	MT8852B-042	MRTSUE06389	1 year	2022/06/08
Modulation Analyzer	HP	HP8901A	MRTSUE06098	1 year	2021/09/26
DC Power Supply	GWINSTEK	DPS-3303C	MRTSUE06064	N/A	N/A
Temperature & Humidity Chamber	BAOYT	BYH-150CL	MRTSUE06051	1 year	2021/10/22
Thermal Hygrometer	testo	608-H1	MRTSUE06401	1 year	2022/06/28
Attenuator	MVE	6dB	MRTSUE06534	1 year	N/A
Attenuator	MVE	10dB	MRTSUE06543	1 year	N/A

Conducted Test Equipment (SIP-TR1)

Instrument	Manufacturer	Type No.	Asset No.	Cali. Interval	Cali. Due Date
EXA Signal Analyzer	KEYSIGHT	N9010B	MRTSUE06603	1 year	2021/11/23
PXA Signal Analyzer	Keysight	N9030B	MRTSUE06395	1 year	2021/08/30
USB wideband power sensor	Agilent	U2021XA	MRTSUE06595	1 year	2021/09/26
USB wideband power sensor	Agilent	U2021XA	MRTSUE06596	1 year	2021/09/26
Temperature Chamber	BAOYT	BYG-408CS	MRTSUE06847	1 year	2022/02/23
Thermal Hygrometer	testo	608-H1	MRTSUE11022	1 year	2021/11/25
Attenuator	MVE	6dB	MRTSUE06534	1 year	N/A
Attenuator	MVE	10dB	MRTSUE06543	1 year	N/A

Software	Version	Function
EMI Software	V3	EMI Test Software

5. Measurement Uncertainty

Where relevant, the following test uncertainty levels have been estimated for tests performed on the EUT as specified in CISPR 16-4-2. This uncertainty represents an expanded uncertainty expressed at approximately the 95% confidence level using a coverage factor of $k = 2$.

AC Conducted Emission Measurement
Measurement Uncertainty for a Level of Confidence of 95% ($U=2Uc(y)$): 9kHz~150kHz: 3.74dB 150kHz~30MHz: 3.44dB
Radiated Disturbance
Measurement Uncertainty for a Level of Confidence of 95% ($U=2Uc(y)$): Horizontal: 30MHz~300MHz: 5.04dB 300MHz~1GHz: 4.95dB 1GHz~40GHz: 6.40dB Vertical: 30MHz~300MHz: 5.24dB 300MHz~1GHz: 6.03dB 1GHz~40GHz: 6.40dB
Spurious Emissions, Conducted
Measuring Uncertainty for a Level of Confidence of 95% ($U=2Uc(y)$): 0.78dB
Output Power
Measuring Uncertainty for a Level of Confidence of 95% ($U=2Uc(y)$): 1.13dB
Power Spectrum Density
Measuring Uncertainty for a Level of Confidence of 95% ($U=2Uc(y)$): 1.15dB
Occupied Bandwidth
Measuring Uncertainty for a Level of Confidence of 95% ($U=2Uc(y)$): 0.28%

6. Test Result

6.1. Summary

FCC Section(s)	Test Description	Test Condition	Test Result	Reference
15.407(a)	26dB Bandwidth	Conducted	Pass	Section 6.2
15.407(e)	6dB Bandwidth		Pass	Section 6.3
15.407(a) (3)	Maximum Conducted Output Power		Pass	Section 6.4
15.407(a) (3)	Power Spectral Density		Pass	Section 6.5
15.407(g)	Frequency Stability		Pass	Section 6.6
15.407(b) (4)(i)	Undesirable Emissions	Radiated	Pass	Section 6.7
15.205, 15.209 15.407(b)(5), (6), (7)	General Field Strength (Restricted Bands and Radiated Emission)		Pass	Section 6.8
15.207	AC Conducted Emissions 150kHz-30MHz	Line Conducted	Pass	Section 6.9

Notes:

- 1) The analyzer plots shown in this section were all taken with a correction table loaded into the analyzer. The correction table was used to account for the losses of the cables and attenuators used as part of the system to connect the EUT to the analyzer at all frequencies of interest.
- 2) All modes of operation and data rates were investigated. For radiated emission test, every axis (X, Y, Z) was also verified. The test results shown in the following sections represent the worst case emissions.
- 3) Test Item "Output Power" was assessed two antenna ports, any others test items were assessed the worst-case antenna port.

6.2. Emission Bandwidth Measurement

6.2.1. Test Limit

N/A

6.2.2. Test Procedure Used

KDB 789033 D02v02r01 -Section C.1

6.2.3. Test Setting

1. Set RBW = approximately 1% of the emission bandwidth.
2. Set the VBW > RBW.
3. Detector = Peak.
4. Trace mode = max hold.
5. Measure the maximum width of the emission that is 26 dB down from the maximum of the emission. Compare this with the RBW setting of the analyzer. Readjust RBW and repeat measurement as needed until the RBW/EBW ratio is approximately 1%.

6.2.4. Test Setup

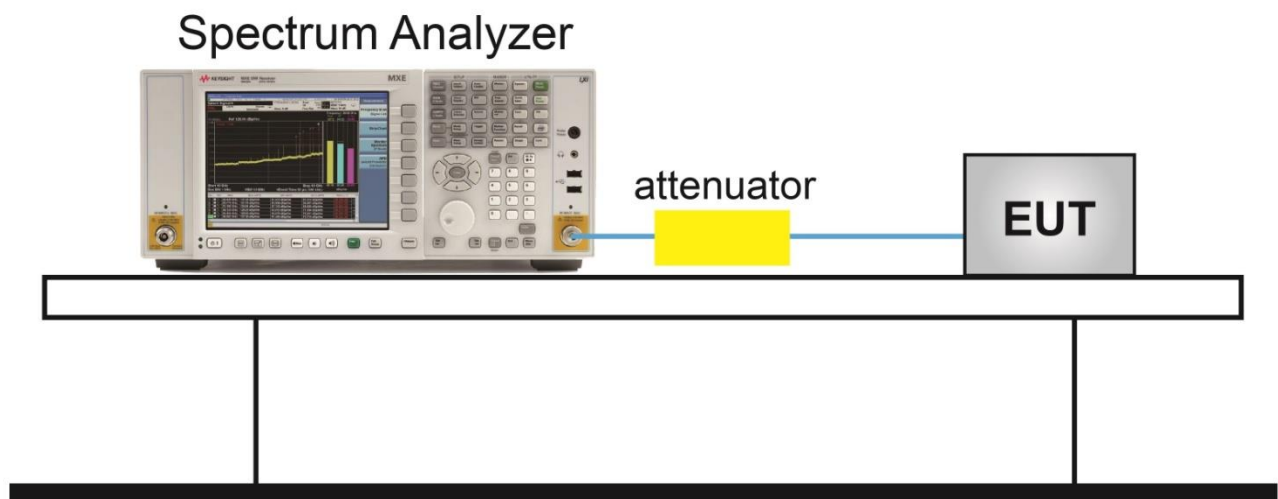

6.2.5. Test Result

Test Site	SIP-TR1	Test Engineer	Alisa Deng
Test Date	2021/07/24 ~ 2021/08/13		

Test Mode	Frequency (MHz)	26dB Bandwidth (MHz)
Full BW	5729	4.00
Full BW	5788	4.00
Full BW	5846	4.00
Half BW	5729	2.00
Half BW	5788	2.00
Half BW	5846	2.00



Half BW 26dB Bandwidth

5729MHz

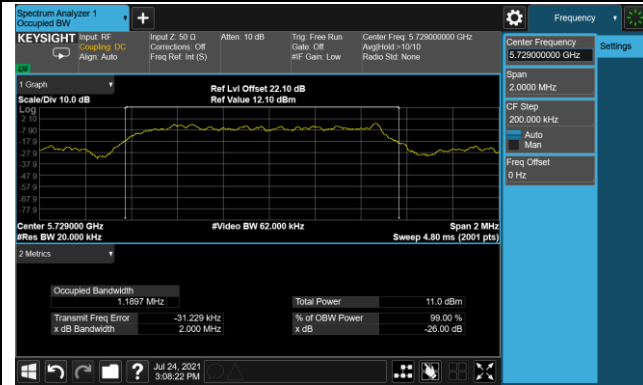

5788MHz

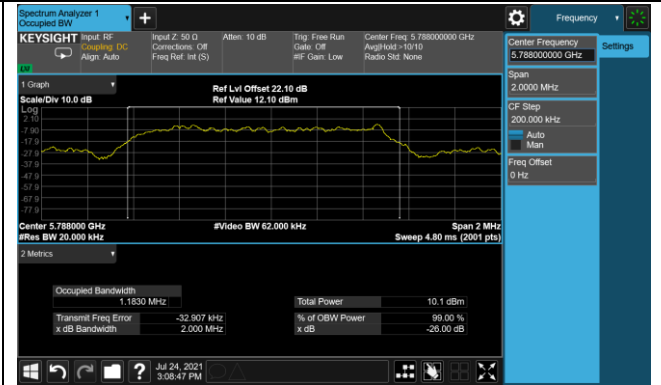

5846MHz

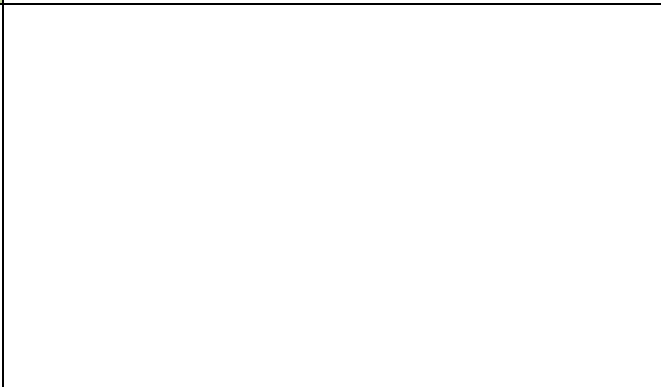
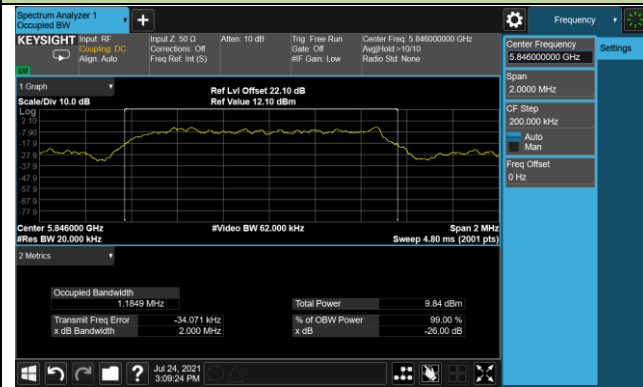

6.3. 6dB Bandwidth Measurement

6.3.1. Test Limit

The minimum 6dB bandwidth shall be at least 500 kHz.

6.3.2. Test Procedure Used

KDB 789033 D02v02r01 - Section C.2

6.3.3. Test Setting

1. Set center frequency to the nominal EUT channel center frequency.
2. RBW = 100 kHz.
3. VBW $\geq 3 \times$ RBW.
4. Detector = Peak.
5. Trace mode = Max hold.
6. Sweep = Auto couple.
7. Allow the trace to stabilize.
8. Measure the maximum width of the emission that is constrained by the frequencies associated with the two outermost amplitude points (upper and lower frequencies) that are attenuated by 6 dB relative to the maximum level measured in the fundamental emission.

6.3.4. Test Setup

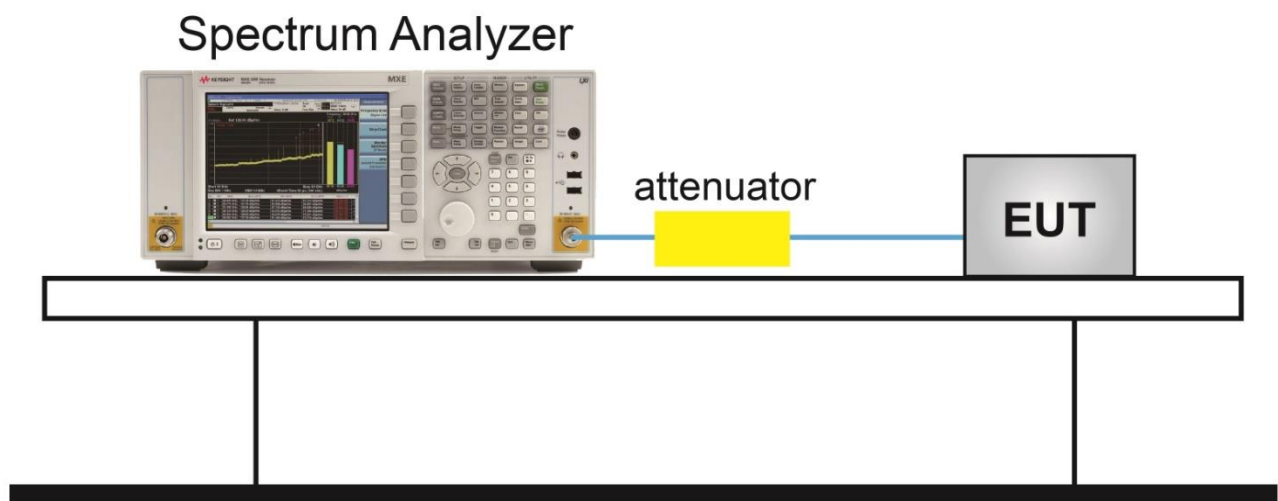

6.3.5. Test Result

Test Site	SIP-TR1	Test Engineer	Alisa Deng
Test Date	2021/07/24		

Test Mode	Frequency (MHz)	6dB Bandwidth (MHz)	Limit (MHz)	Result
Full BW	5729	2.030	≥ 0.5	Pass
Full BW	5788	2.036	≥ 0.5	Pass
Full BW	5846	2.033	≥ 0.5	Pass
Half BW	5729	1.028	≥ 0.5	Pass
Half BW	5788	1.021	≥ 0.5	Pass
Half BW	5846	1.022	≥ 0.5	Pass



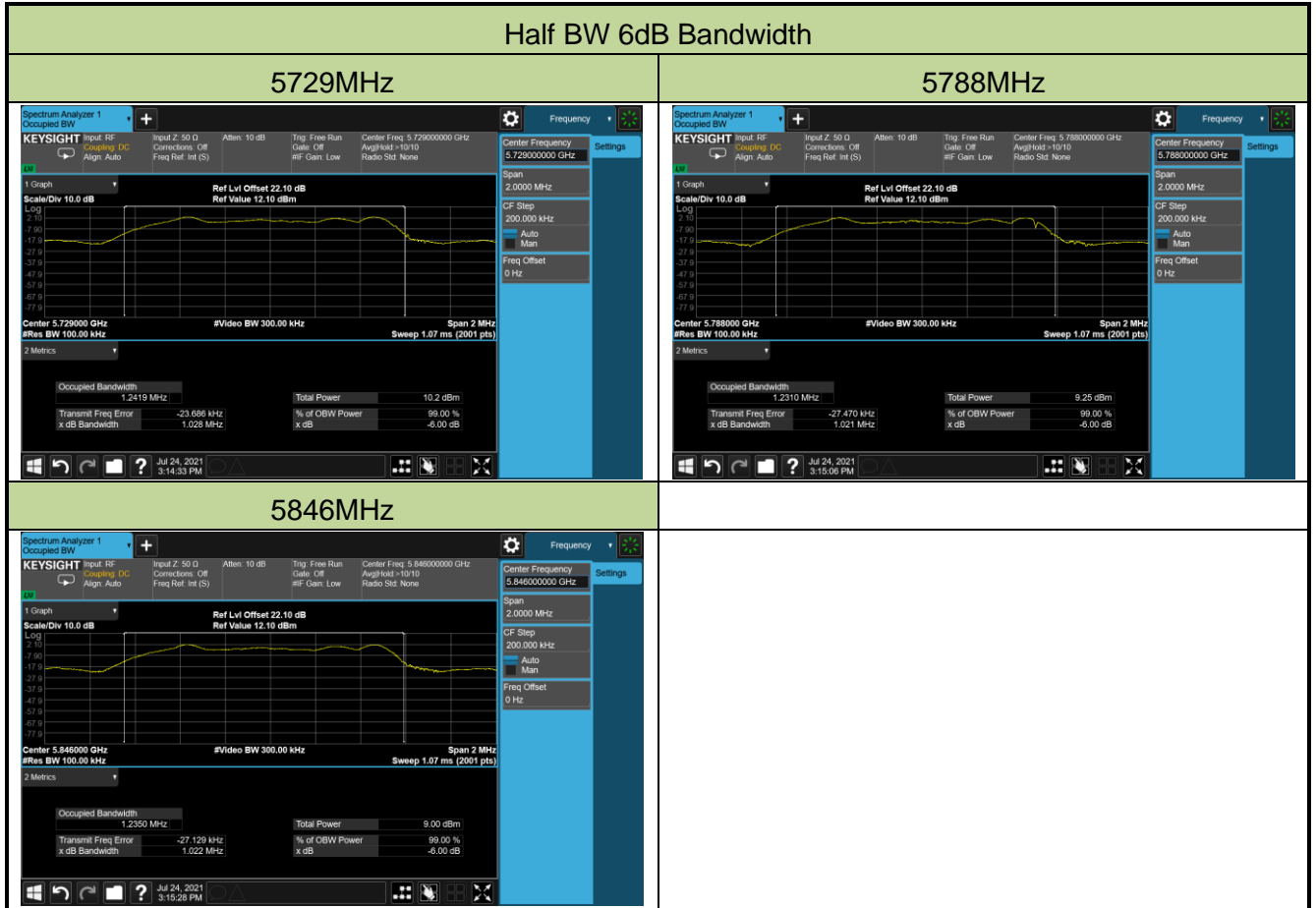

6.4. Output Power Measurement

6.4.1. Test Limit

For the band 5.725-5.85 GHz, the maximum conducted output power over the frequency band of operation shall not exceed 1 W (30dBm).

If transmitting antennas of directional gain greater than 6dBi are used, the maximum conducted output power shall be reduced by the amount in dB that the directional gain of the antenna exceeds 6dBi.

6.4.2. Test Procedure Used

KDB 789033D02v02r01- Section E)3)b) Method PM-G

6.4.3. Test Setting

Average power measurements were performed only when the EUT was transmitting at its maximum power control level using a broadband power meter with a pulse sensor. The power meter implemented triggering and gating capabilities which were set up such that power measurements were recorded only during the ON time of the transmitter.

6.4.4. Test Setup

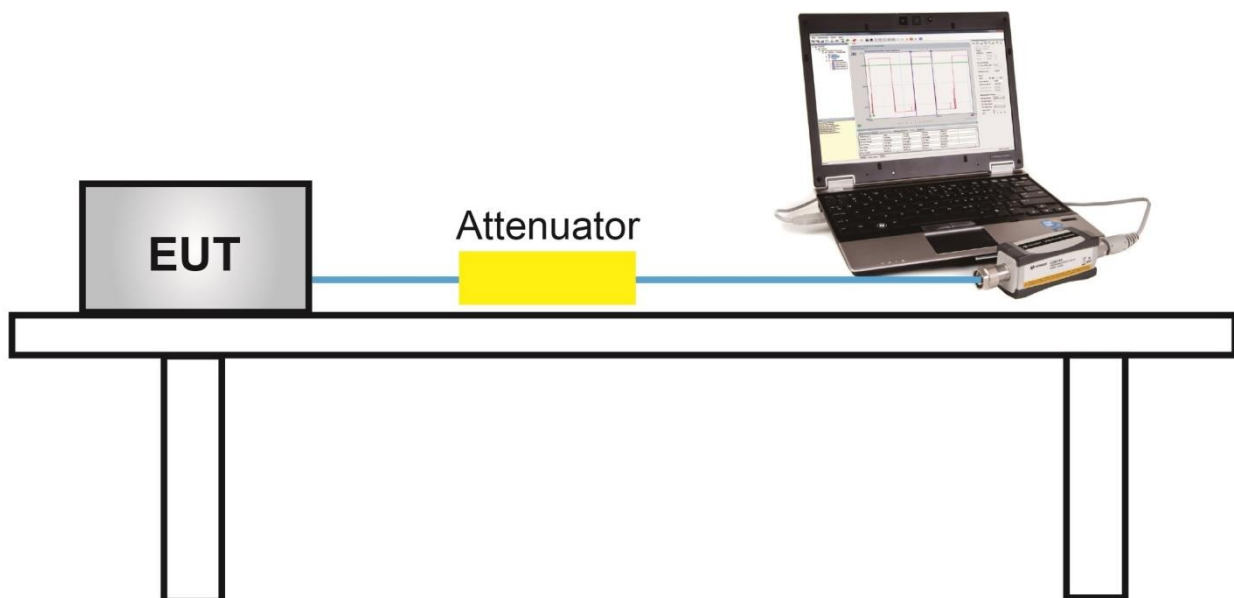

6.4.5. Test Result

Test Site	SIP-TR1	Test Engineer	Alisa Deng
Test Date	2021/08/02		

Test Mode	Freq. (MHz)	Average Power (dBm)		Power Limit (dBm)	Result
		Ant a	Ant b		
Full BW	5729	4.11	4.05	≤ 30.00	Pass
Full BW	5788	3.74	3.48	≤ 30.00	Pass
Full BW	5846	3.11	2.82	≤ 30.00	Pass
Half BW	5729	4.35	4.38	≤ 30.00	Pass
Half BW	5788	3.82	3.24	≤ 30.00	Pass
Half BW	5846	3.06	2.88	≤ 30.00	Pass

6.5. Power Spectral Density Measurement

6.5.1. Test Limit

For the band 5.725-5.85 GHz, the maximum power spectral density shall not exceed 30 dBm in any 500-kHz band.

If transmitting antennas of directional gain greater than 6dBi are used, the peak power spectral density shall be reduced by the amount in dB that the directional gain of the antenna exceeds 6dBi.

6.5.2. Test Procedure Used

KDB 789033 D02v02r01 - Section F

6.5.3. Test Setting

1. Analyzer was set to the center frequency of the UNII channel under investigation
2. Span was set to encompass the entire 26dB EBW of the signal.
RBW = 510kHz
VBW = 1.5MHz
3. Number of sweep points $\geq 2 \times (\text{span} / \text{RBW})$
4. Detector = Power averaging (Average)
5. Trace average at least 100 traces in power averaging (rms) mode
6. Sweep time = Auto
7. Trigger = Free run
8. Use the peak search function on the instrument to find the peak of the spectrum and record its value.
9. Add $10 \cdot \log(1/x)$, where x is the duty cycle, to the measured power in order to compute the average power during the actual transmission times (because the measurement represents an average over both the on and off times of the transmission). For example, add $10 \cdot \log(1/0.25) = 6$ dB if the duty cycle is 25 percent.

6.5.4. Test Setup

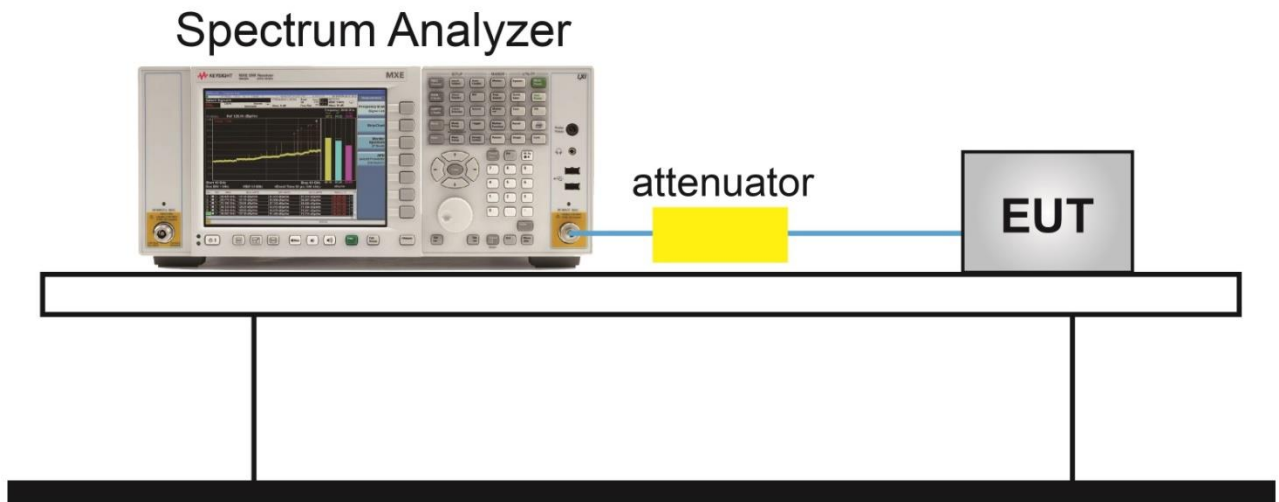

6.5.5. Test Result

Test Site	SIP-TR1	Test Engineer	Alisa Deng
Test Date	2021/07/24		

Test Mode	Freq. (MHz)	Duty Cycle (%)	PSD (dBm / 510kHz)	Final PSD (dBm / 510kHz)	Limit (dBm / 510kHz)	Result
Full BW	5729	60.00	-2.65	-0.43	≤ 30.00	Pass
Full BW	5788	60.00	-5.16	-2.94	≤ 30.00	Pass
Full BW	5846	60.00	-6.29	-4.07	≤ 30.00	Pass
Half BW	5729	80.25	-0.54	0.42	≤ 30.00	Pass
Half BW	5788	80.25	-1.76	-0.81	≤ 30.00	Pass
Half BW	5846	80.25	-2.79	-1.83	≤ 30.00	Pass

Note: When EUT duty cycle < 98%, Final PSD (dBm / 500kHz) = PSD (dBm / 500kHz) + 10*log(1/Duty cycle)

Full BW Power Spectral Density - Ant b

5729MHz

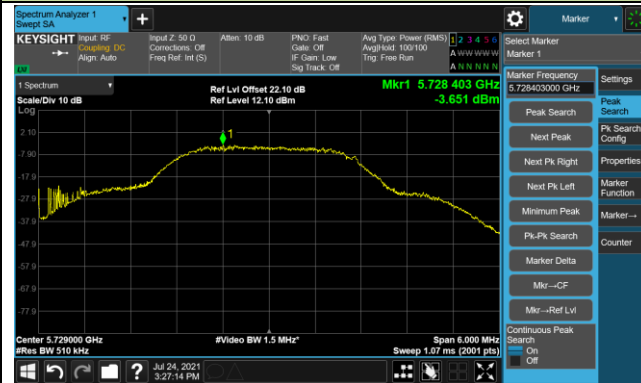

5788MHz

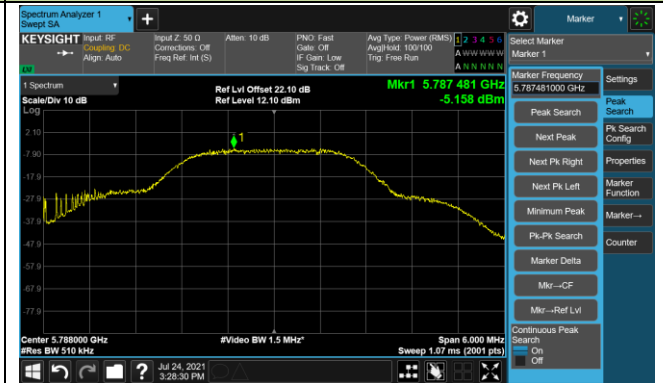

5846MHz

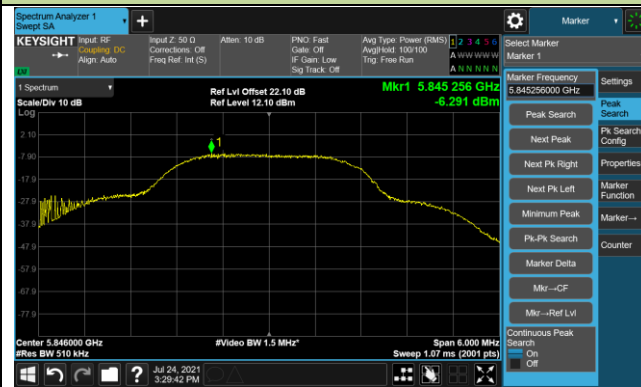

Half BW Power Spectral Density - Ant b

5729MHz



5788MHz

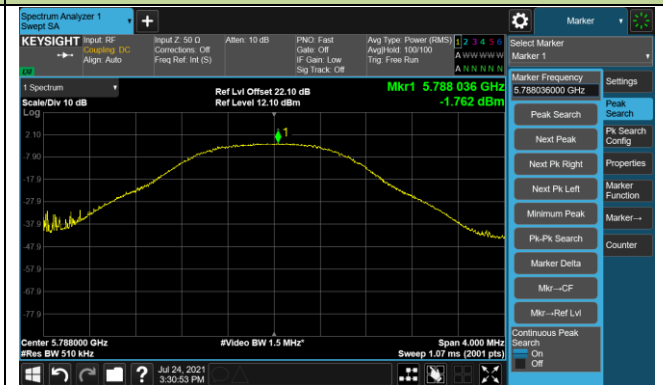

5846MHz



6.6. Frequency Stability Measurement

6.6.1. Test Limit

Manufacturers of U-NII devices are responsible for ensuring frequency stability such that an emission is maintained within the band of operation under all conditions of normal operation as specified in the user's manual.

6.6.2. Test Procedure Used

Frequency Stability Under Temperature Variations:

The equipment under test was connected to an external AC or DC power supply and input rated voltage. RF output was connected to a frequency counter or spectrum analyzer via feed through attenuators. The EUT was placed inside the temperature chamber. Set the spectrum analyzer RBW low enough to obtain the desired frequency resolution and measure EUT 20°C operating frequency as reference frequency. Turn EUT off and set the chamber temperature to highest. After the temperature stabilized for approximately 30 minutes recorded the frequency. Repeat step measure with 10°C decreased per stage until the lowest temperature reached.

Frequency Stability Under Voltage Variations:

Set chamber temperature to 20°C. Use a variable AC power supply / DC power source to power the EUT and set the voltage to rated voltage. Set the spectrum analyzer RBW low enough to obtain the desired frequency resolution and recorded the frequency.

Reduce the input voltage to specify extreme voltage variation ($\pm 15\%$) and endpoint, record the maximum frequency change. For hand-carried battery-powered equipment, primary supply voltage is reduced to the battery operating end point which shall be specified by the manufacturer.

6.6.3. Test Setup

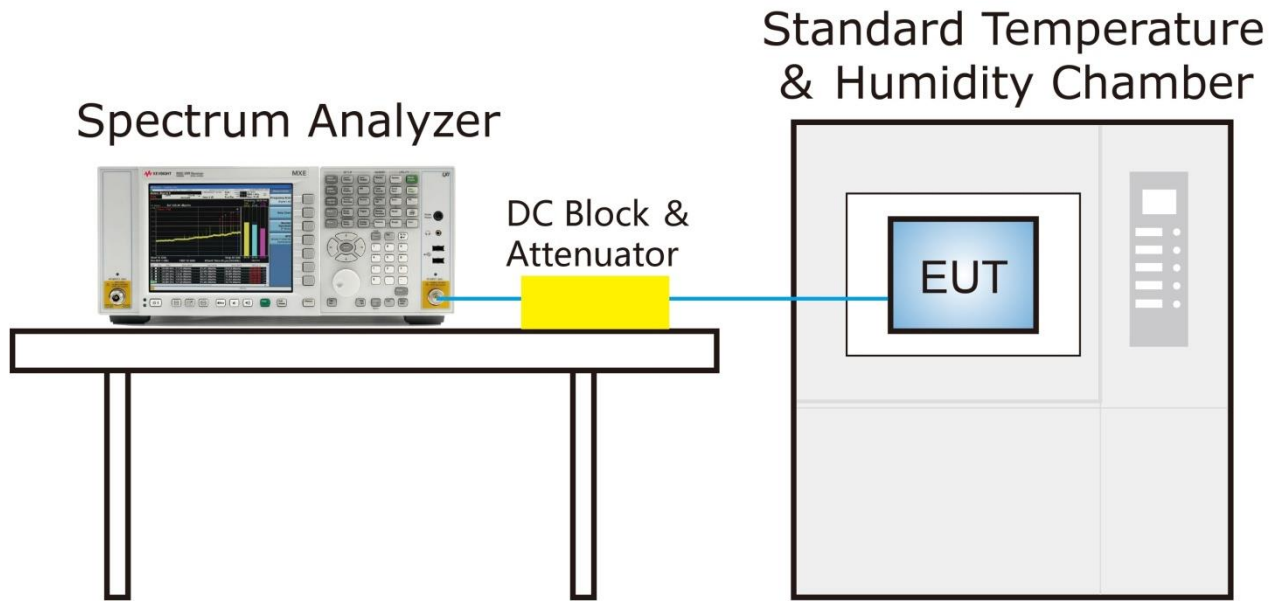

6.6.4. Test Result

Test Site	SIP-TR1	Test Engineer	Alisa Deng
Test Date	2021/07/23~2021/07/24	Test Channel	5729MHz (Carrier Mode)

Voltage (%)	Power (V _{AC})	Temp (°C)	Frequency Tolerance (ppm)			
			0 minutes	2 minutes	5 minutes	10 minutes
100	120	- 30	3.59	8.93	5.89	7.63
		- 20	7.89	6.89	7.11	9.83
		- 10	8.01	7.12	9.54	8.72
		0	8.97	6.55	7.70	8.56
		+ 10	6.38	7.23	5.37	6.33
		+ 20	4.52	4.39	3.57	3.95
		+ 30	1.64	2.53	6.74	3.66
		+ 40	2.14	1.77	1.99	2.66
		+ 50	2.56	1.28	3.84	2.55
90	108	+ 20	5.25	5.40	3.81	4.28
110	132	+ 20	4.10	4.13	4.12	3.80

Note: Frequency Tolerance (ppm) = {[Measured Frequency (MHz) - Declared Frequency (MHz)] / Declared Frequency (MHz)} * 10⁶.

6.7. Radiated Spurious Emission Measurement

6.7.1. Test Limit

All out of band emissions appearing in a restricted band as specified in Section 15.205 of the Title 47 CFR must not exceed the limits shown in Table per Section 15.209.

FCC Part 15 Subpart C Paragraph 15.209		
Frequency (MHz)	Field Strength ($\mu\text{V/m}$)	Measured Distance (m)
0.009 - 0.490	2400/F (kHz)	300
0.490 - 1.705	24000/F (kHz)	30
1.705 - 30	30	30
30 - 88	100	3
88 - 216	150	3
216 - 960	200	3
Above 960	500	3

6.7.2. Test Procedure Used

KDB 789033 D02v02r01- Section G

6.7.3. Test Setting

Table 1 - RBW as a function of frequency

Frequency	RBW
9 ~ 150 kHz	200 ~ 300 Hz
0.15 ~ 30 MHz	9 ~ 10 kHz
30 ~ 1000 MHz	100 ~ 120 kHz
> 1000 MHz	1 MHz

Quasi-Peak Measurements below 1GHz

1. Analyzer center frequency was set to the frequency of the radiated spurious emission of interest
2. Span was set greater than 1MHz
3. RBW = as specified in Table 1
4. Detector = CISPR quasi-peak
5. Sweep time = auto couple
6. Trace was allowed to stabilize

Peak Measurements above 1GHz

1. Analyzer center frequency was set to the frequency of the radiated spurious emission of interest
2. RBW = 1MHz
3. VBW = 3MHz
4. Detector = peak
5. Sweep time = auto couple
6. Trace mode = max hold
7. Trace was allowed to stabilize

Average Measurements above 1GHz (Method VB)

1. Analyzer center frequency was set to the frequency of the radiated spurious emission of interest
2. RBW = 1MHz
3. VBW; If the EUT is configured to transmit with duty cycle $\geq 98\%$, set VBW = 10Hz
If the EUT duty cycle is $< 98\%$, set VBW $\geq 1/T$. T is the minimum transmission duration
4. Detector = Peak
5. Sweep time = auto
6. Trace mode = max hold
7. Trace was allowed to stabilize

6.7.4. Test Setup

Below 1GHz Test Setup:

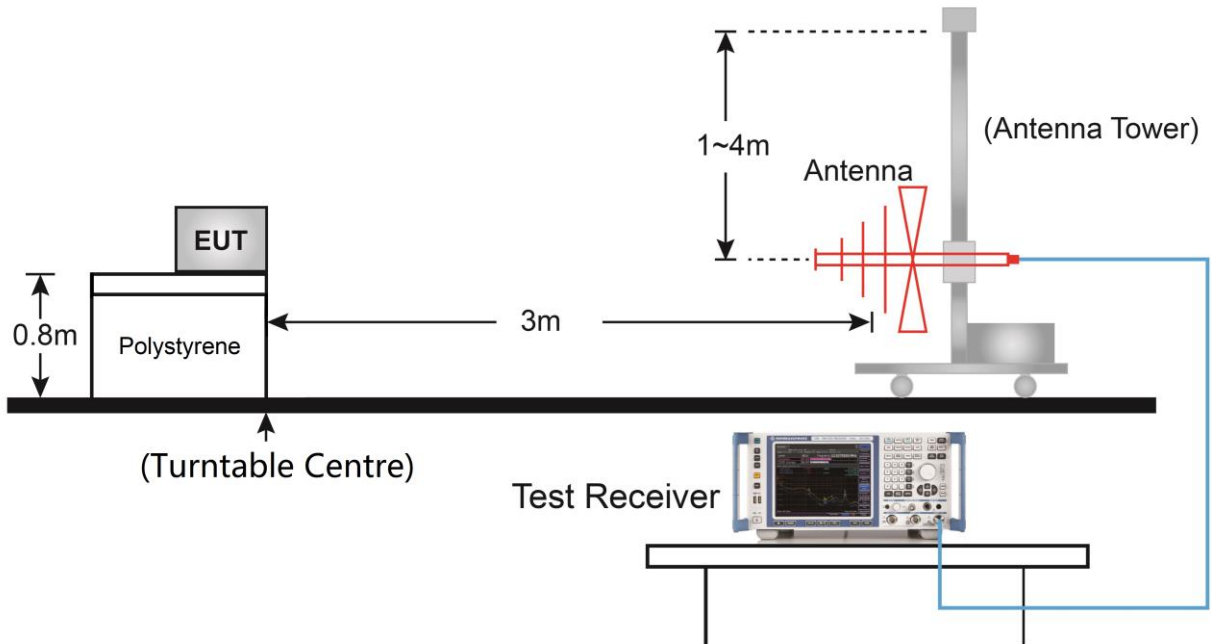

Above 1GHz Test Setup:

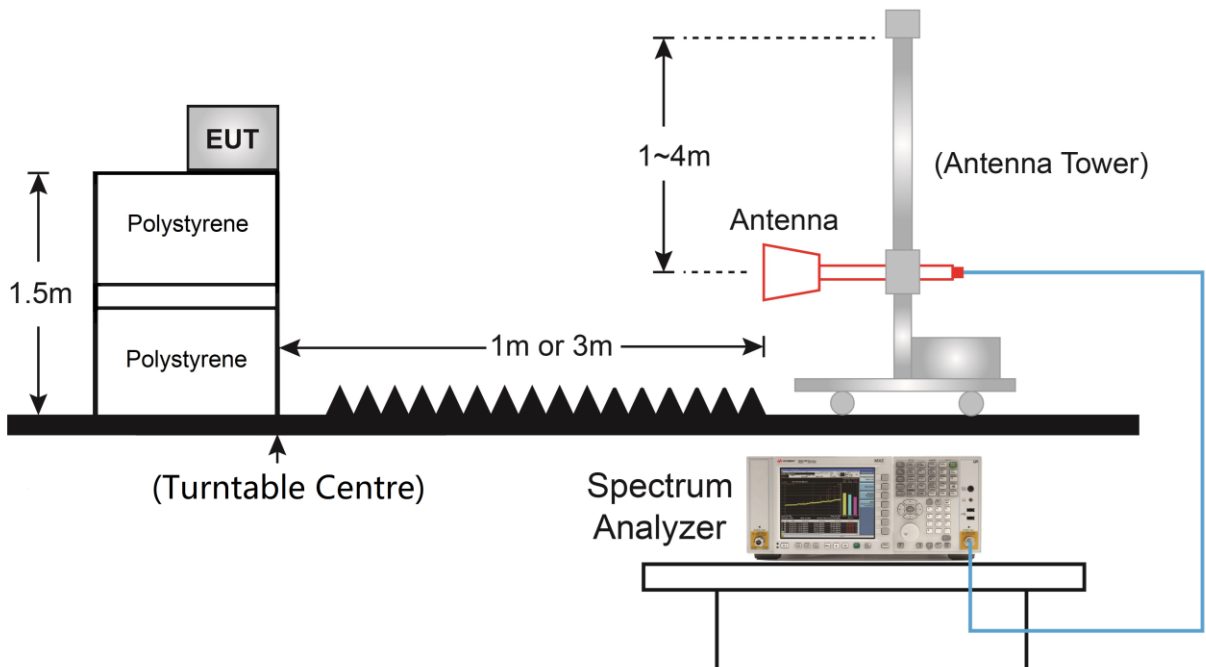

6.7.5. Test Result

Test Site	SIP-AC1	Test Engineer	Yien Qian
Test Date	2021/08/03	Test Frequency	5729MHz
Test Mode	Full BW		
Remark	1. Average measurement was not performed if peak level lower than average limit. 2. Other frequency was 20dB below limit line within 1-18GHz, there is not show in the report.		

Mark	Frequency (MHz)	Reading Level (dB μ V)	Factor (dB)	Measure Level (dB μ V/m)	Limit (dB μ V/m)	Margin (dB)	Detector	Polarization
	8412.0	50.7	-6.1	44.6	74.0	-29.4	Peak	Horizontal
*	9636.0	50.5	-5.4	45.1	68.2	-23.1	Peak	Horizontal
	12169.0	49.2	-3.7	45.5	74.0	-28.5	Peak	Horizontal
*	13767.0	48.7	-1.0	47.7	68.2	-20.5	Peak	Horizontal
	8395.0	50.8	-5.9	44.9	74.0	-29.1	Peak	Vertical
*	10044.0	50.3	-5.1	45.2	68.2	-23.0	Peak	Vertical
	11693.0	50.2	-4.6	45.6	74.0	-28.4	Peak	Vertical
*	13826.5	48.7	-0.9	47.8	68.2	-20.4	Peak	Vertical

Note 1: “*” is not in restricted band, its limit is -27dBm/MHz. At a distance of 3 meters, the field strength limit in dB μ V/m can be determined by adding a “conversion” factor of 95.2dB to the EIRP limit of -27dBm/MHz to obtain the limit for out of band spurious emissions.

Note 2: Measure Level (dB μ V/m) = Reading Level (dB μ V) + Factor (dB)

Factor (dB) = Cable Loss (dB) + Antenna Factor (dB/m) - Pre_Amplifier Gain (dB)

Test Site	SIP-AC1	Test Engineer	Yien Qian
Test Date	2021/08/03	Test Frequency	5788MHz
Test Mode	Full BW		
Remark	1. Average measurement was not performed if peak level lower than average limit. 2. Other frequency was 20dB below limit line within 1-18GHz, there is not show in the report.		

Mark	Frequency (MHz)	Reading Level (dB μ V)	Factor (dB)	Measure Level (dB μ V/m)	Limit (dB μ V/m)	Margin (dB)	Detector	Polarization
	8412.0	51.4	-6.1	45.3	74.0	-28.7	Peak	Horizontal
*	9746.5	50.3	-5.4	44.9	68.2	-23.3	Peak	Horizontal
	11846.0	49.7	-4.4	45.3	74.0	-28.7	Peak	Horizontal
*	13665.0	49.4	-1.8	47.6	68.2	-20.6	Peak	Horizontal
	8403.5	50.6	-6.0	44.6	74.0	-29.4	Peak	Vertical
*	10044.0	50.3	-5.1	45.2	68.2	-23.0	Peak	Vertical
	11574.0	49.6	-4.7	44.9	74.0	-29.1	Peak	Vertical
*	14073.0	48.1	-0.7	47.4	68.2	-20.8	Peak	Vertical

Note 1: "*" is not in restricted band, its limit is -27dBm/MHz. At a distance of 3 meters, the field strength limit in dB μ V/m can be determined by adding a "conversion" factor of 95.2dB to the EIRP limit of -27dBm/MHz to obtain the limit for out of band spurious emissions.

Note 2: Measure Level (dB μ V/m) = Reading Level (dB μ V) + Factor (dB)

Factor (dB) = Cable Loss (dB) + Antenna Factor (dB/m) - Pre_Amplifier Gain (dB)

Test Site	SIP-AC1	Test Engineer	Yien Qian
Test Date	2021/08/03	Test Frequency	5846MHz
Test Mode	Full BW		
Remark	1. Average measurement was not performed if peak level lower than average limit. 2. Other frequency was 20dB below limit line within 1-18GHz, there is not show in the report.		

Mark	Frequency (MHz)	Reading Level (dB μ V)	Factor (dB)	Measure Level (dB μ V/m)	Limit (dB μ V/m)	Margin (dB)	Detector	Polarization
	8446.0	50.5	-6.0	44.5	74.0	-29.5	Peak	Horizontal
*	9848.5	50.6	-5.3	45.3	68.2	-22.9	Peak	Horizontal
	11285.0	50.2	-5.1	45.1	74.0	-28.9	Peak	Horizontal
*	13852.0	47.7	-1.0	46.7	68.2	-21.5	Peak	Horizontal
	8429.0	50.6	-6.0	44.6	74.0	-29.4	Peak	Vertical
*	9857.0	50.5	-5.3	45.2	68.2	-23.0	Peak	Vertical
	11922.5	49.8	-4.3	45.5	74.0	-28.5	Peak	Vertical
*	14353.5	47.9	0.2	48.1	68.2	-20.1	Peak	Vertical

Note 1: "*" is not in restricted band, its limit is -27dBm/MHz. At a distance of 3 meters, the field strength limit in dB μ V/m can be determined by adding a "conversion" factor of 95.2dB to the EIRP limit of -27dBm/MHz to obtain the limit for out of band spurious emissions.

Note 2: Measure Level (dB μ V/m) = Reading Level (dB μ V) + Factor (dB)

Factor (dB) = Cable Loss (dB) + Antenna Factor (dB/m) - Pre_Amplifier Gain (dB)

Test Site	SIP-AC1	Test Engineer	Yien Qian
Test Date	2021/08/03	Test Frequency	5729MHz
Test Mode	Half BW		
Remark	1. Average measurement was not performed if peak level lower than average limit. 2. Other frequency was 20dB below limit line within 1-18GHz, there is not show in the report.		

Mark	Frequency (MHz)	Reading Level (dB μ V)	Factor (dB)	Measure Level (dB μ V/m)	Limit (dB μ V/m)	Margin (dB)	Detector	Polarization
	8395.0	50.7	-5.9	44.8	74.0	-29.2	Peak	Horizontal
*	10035.5	50.7	-5.2	45.5	68.2	-22.7	Peak	Horizontal
	12041.5	49.9	-4.0	45.9	74.0	-28.1	Peak	Horizontal
*	13954.0	48.7	-0.9	47.8	68.2	-20.4	Peak	Horizontal
	8148.5	50.4	-6.0	44.4	74.0	-29.6	Peak	Vertical
*	10001.5	50.2	-5.1	45.1	68.2	-23.1	Peak	Vertical
	12381.5	50.0	-3.5	46.5	74.0	-27.5	Peak	Vertical
*	14115.5	49.0	-0.4	48.6	68.2	-19.6	Peak	Vertical

Note 1: “*” is not in restricted band, its limit is -27dBm/MHz. At a distance of 3 meters, the field strength limit in dB μ V/m can be determined by adding a “conversion” factor of 95.2dB to the EIRP limit of -27dBm/MHz to obtain the limit for out of band spurious emissions.

Note 2: Measure Level (dB μ V/m) = Reading Level (dB μ V) + Factor (dB)

Factor (dB) = Cable Loss (dB) + Antenna Factor (dB/m) - Pre_Amplifier Gain (dB)

Test Site	SIP-AC1	Test Engineer	Yien Qian
Test Date	2021/08/03	Test Frequency	5788MHz
Test Mode	Half BW		
Remark	1. Average measurement was not performed if peak level lower than average limit. 2. Other frequency was 20dB below limit line within 1-18GHz, there is not show in the report.		

Mark	Frequency (MHz)	Reading Level (dB μ V)	Factor (dB)	Measure Level (dB μ V/m)	Limit (dB μ V/m)	Margin (dB)	Detector	Polarization
	8335.5	50.8	-5.9	44.9	74.0	-29.1	Peak	Horizontal
*	9857.0	50.2	-5.3	44.9	68.2	-23.3	Peak	Horizontal
	12271.0	49.6	-3.6	46.0	74.0	-28.0	Peak	Horizontal
*	13818.0	47.9	-0.9	47.0	68.2	-21.2	Peak	Horizontal
	8403.5	51.0	-6.0	45.0	74.0	-29.0	Peak	Vertical
*	9942.0	50.2	-5.2	45.0	68.2	-23.2	Peak	Vertical
	10953.5	50.6	-5.3	45.3	74.0	-28.7	Peak	Vertical
*	14115.5	48.3	-0.4	47.9	68.2	-20.3	Peak	Vertical

Note 1: "*" is not in restricted band, its limit is -27dBm/MHz. At a distance of 3 meters, the field strength limit in dB μ V/m can be determined by adding a "conversion" factor of 95.2dB to the EIRP limit of -27dBm/MHz to obtain the limit for out of band spurious emissions.

Note 2: Measure Level (dB μ V/m) = Reading Level (dB μ V) + Factor (dB)

Factor (dB) = Cable Loss (dB) + Antenna Factor (dB/m) - Pre_Amplifier Gain (dB)

Test Site	SIP-AC1	Test Engineer	Yien Qian
Test Date	2021/08/03	Test Frequency	5846MHz
Test Mode	Half BW		
Remark	1. Average measurement was not performed if peak level lower than average limit. 2. Other frequency was 20dB below limit line within 1-18GHz, there is not show in the report.		

Mark	Frequency (MHz)	Reading Level (dB μ V)	Factor (dB)	Measure Level (dB μ V/m)	Limit (dB μ V/m)	Margin (dB)	Detector	Polarization
	8242.0	50.9	-5.6	45.3	74.0	-28.7	Peak	Horizontal
*	9653.0	51.0	-5.2	45.8	68.2	-22.4	Peak	Horizontal
	12092.5	49.4	-4.0	45.4	74.0	-28.6	Peak	Horizontal
*	14013.5	49.1	-0.7	48.4	68.2	-19.8	Peak	Horizontal
	8403.5	51.4	-6.0	45.4	74.0	-28.6	Peak	Vertical
*	10180.0	50.4	-5.1	45.3	68.2	-22.9	Peak	Vertical
	12305.0	49.4	-3.7	45.7	74.0	-28.3	Peak	Vertical
*	13988.0	48.6	-1.1	47.5	68.2	-20.7	Peak	Vertical

Note 1: "*" is not in restricted band, its limit is -27dBm/MHz. At a distance of 3 meters, the field strength limit in dB μ V/m can be determined by adding a "conversion" factor of 95.2dB to the EIRP limit of -27dBm/MHz to obtain the limit for out of band spurious emissions.

Note 2: Measure Level (dB μ V/m) = Reading Level (dB μ V) + Factor (dB)

Factor (dB) = Cable Loss (dB) + Antenna Factor (dB/m) - Pre_Amplifier Gain (dB)

The Result of Radiated Emission below 1GHz:

Site: SIP-AC1	Time: 2021/08/03 - 10:29
Limit: FCC_Part15.209_RE(3m)	Engineer: Yien Qian
Probe: SIP-AC1_VULB 9168 _30-1000MHz	Polarity: Horizontal
EUT: Wireless Guitar Pedal Receiver	Power: AC 120V/60Hz
Test Mode: Transmit by Full mode bandwidth at channel 5788MHz	

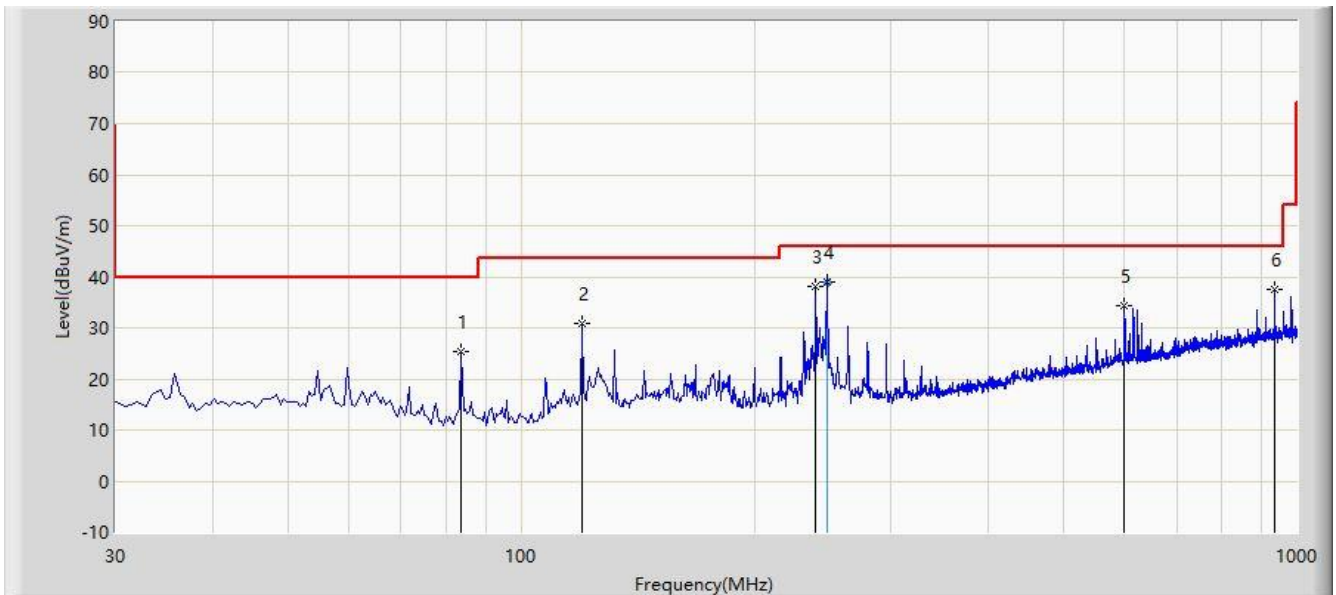

No	Flag	Mark	Frequency (MHz)	Measure Level (dBuV/m)	Reading Level (dBuV)	Margin (dB)	Limit (dBuV/m)	Factor (dB/m)	Type
1			83.835	25.502	13.121	-14.498	40.000	12.381	PK
2			119.725	30.784	15.203	-12.716	43.500	15.581	PK
3			240.005	38.115	21.981	-7.885	46.000	16.135	PK
4		*	247.970	39.079	22.600	-6.921	46.000	16.479	QP
5			599.875	34.226	9.210	-11.774	46.000	25.015	PK
6			935.980	37.488	8.400	-8.512	46.000	29.088	PK

Note 1: Measure Level (dBuV/m) = Reading Level (dBuV) + Factor (dB)

Factor (dB) = Cable Loss (dB) + Antenna Factor (dB/m)

Note 2: The amplitude of radiated emissions (frequency range from 9kHz to 30MHz and 18GHz to 40GHz) is that proximity to ambient noise, which also are attenuated more than 20 dB below the permissible value.

Therefore, the data is not presented in the report.

Site: SIP-AC1	Time: 2021/08/03 - 10:33
Limit: FCC_Part15.209_RE(3m)	Engineer: Yien Qian
Probe: SIP-AC1_VULB 9168 _30-1000MHz	Polarity: Vertical
EUT: Wireless Guitar Pedal Receiver	Power: AC 120V/60Hz
Test Mode: Transmit by Full mode bandwidth at channel 5788MHz	

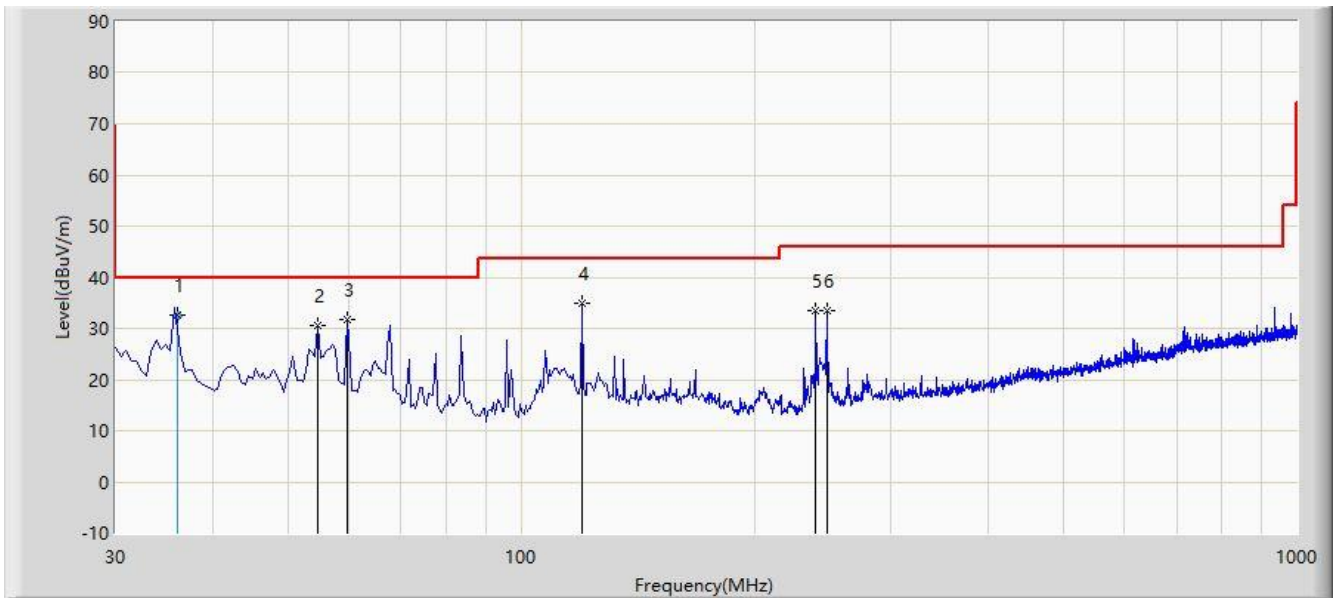

No	Flag	Mark	Frequency (MHz)	Measure Level (dBuV/m)	Reading Level (dBuV)	Margin (dB)	Limit (dBuV/m)	Factor (dB/m)	Type
1		*	36.020	32.509	15.400	-7.491	40.000	17.109	QP
2			54.735	30.628	13.217	-9.372	40.000	17.411	PK
3			59.585	31.832	14.807	-8.168	40.000	17.025	PK
4			119.725	34.836	19.255	-8.664	43.500	15.581	PK
5			240.005	33.560	17.426	-12.440	46.000	16.135	PK
6			247.765	33.565	17.093	-12.435	46.000	16.472	PK

Note 1: Measure Level (dB μ V/m) = Reading Level (dB μ V) + Factor (dB)

Factor (dB) = Cable Loss (dB) + Antenna Factor (dB/m)

Note 2: The amplitude of radiated emissions (frequency range from 9kHz to 30MHz and 18GHz to 40GHz) is that proximity to ambient noise, which also are attenuated more than 20 dB below the permissible value.

Therefore, the data is not presented in the report.

6.8. Radiated Restricted Band Edge Measurement

6.8.1. Test Limit

For 15.205 Requirement:

Radiated emissions which fall in the restricted bands, as defined in Section 15.205(a) of FCC part 15, must also comply with the radiated emission limits specified in Section 15.209(a).

Frequency (MHz)	Frequency (MHz)	Frequency (MHz)	Frequency (GHz)
0.090 - 0.110	16.42-16.423	399.9 - 410	4.5-5.15
¹ 0.495 - 0.505	16.69475-16.69525	608 - 614	5.35-5.46
2.1735-2.1905	16.80425-16.80475	960 - 1240	7.25-7.75
4.125-4.128	25.5 -25.67	1300 - 1427	8.025 - 8.5
4.17725-4.17775	37.5-38.25	1435-1626.5	9.0-9.2
4.20725-4.20775	73-74.6	1645.5-1646.5	9.3-9.5
6.215-6.218	74.8-75.2	1660 - 1710	10.6-12.7
6.26775-6.26825	108-121.94	1718.8-1722.2	13.25-13.4
6.31175-6.31225	123 - 138	2200 - 2300	14.47-14.5
8.291-8.294	149.9-150.05	2310-2390	15.35-16.2
8.362-8.366	156.52475-156.52525	2483.5 - 2500	17.7-21.4
8.37625-8.38675	156.7-156.9	2690 - 2900	22.01-23.12
8.41425-8.41475	162.0125-167.17	3260 - 3267	23.6-24.0
12.29-12.293	167.72-173.2	3332 - 3339	31.2-31.8
12.51975-12.52025	240 - 285	3345.8 - 3358	36.43-36.5
12.57675-12.57725	322-335.4	3600 - 4400	(²)
13.36-13.41	--	--	--

For 15.407(b) Requirement:

For transmitters operating in the 5.725-5.85 GHz band: All emissions within the frequency range from the band edge to 10 MHz above or below the band edge shall not exceed an e.i.r.p. of -17 dBm/MHz; for frequencies 10 MHz or greater above or below the band edge, emissions shall not exceed an e.i.r.p. of -27 dBm/MHz.

Refer to KDB 789033 D02v02r01 G)2)c), as specified in § 15.407(b), emissions above 1000 MHz that are outside of the restricted bands are subject to a maximum emission limit of -27 dBm/MHz (or -17 dBm/MHz as specified in § 15.407(b)(4)). However, an out-of-band emission that complies with

both the peak and average limits of § 15.209 is not required to satisfy the -27 dBm/MHz or -17 dBm/MHz maximum emission limit.

All out of band emissions appearing in a restricted band as specified in Section 15.205 of the Title 47CFR must not exceed the limits shown in Table per Section 15.209.

FCC Part 15 Subpart C Paragraph 15.209		
Frequency (MHz)	Field Strength ($\mu\text{V}/\text{m}$)	Measured Distance (m)
0.009 - 0.490	2400/F (kHz)	300
0.490 - 1.705	24000/F (kHz)	30
1.705 - 30	30	30
30 - 88	100	3
88 - 216	150	3
216 - 960	200	3
Above 960	500	3

6.8.2. Test Procedure Used

KDB 789033 D02v02r01- Section G

6.8.3. Test Setting

Peak Measurements above 1GHz

1. Analyzer center frequency was set to the frequency of the radiated spurious emission of interest
2. RBW = 1MHz
3. VBW = 3MHz
4. Detector = Peak
5. Sweep time = Auto couple
6. Trace mode = Max hold
7. Trace was allowed to stabilize

Average Measurements above 1GHz (Method VB)

1. Analyzer center frequency was set to the frequency of the radiated spurious emission of interest
2. RBW = 1MHz
3. VBW; if the EUT is configured to transmit with duty cycle $\geq 98\%$, set VBW = 10Hz
4. If the EUT duty cycle is $< 98\%$, set VBW $\geq 1/T$. T is the minimum transmission duration
5. Detector = Peak
6. Sweep time = Auto
7. Trace mode = Max hold
8. Trace was allowed to stabilize

6.8.4. Test Setup

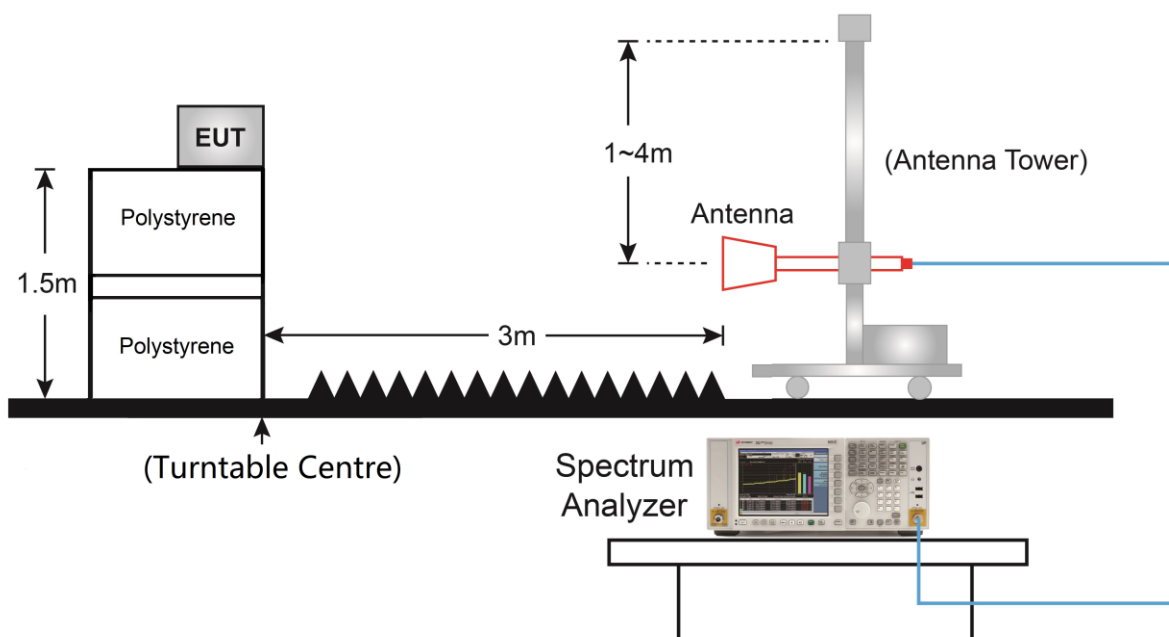

6.8.5. Test Result

Site: SIP-AC3	Time: 2021/08/10 - 14:22
Limit: FCC_Part15.209_RE(3m)	Engineer: Yien Qian
Probe: SIP-AC3_HF907_102861_1-18GHz	Polarity: Horizontal
EUT: Wireless Guitar Pedal Receiver	Power: AC 120V/60Hz
Test Mode: Transmit by Full BW at Channel 5729MHz	

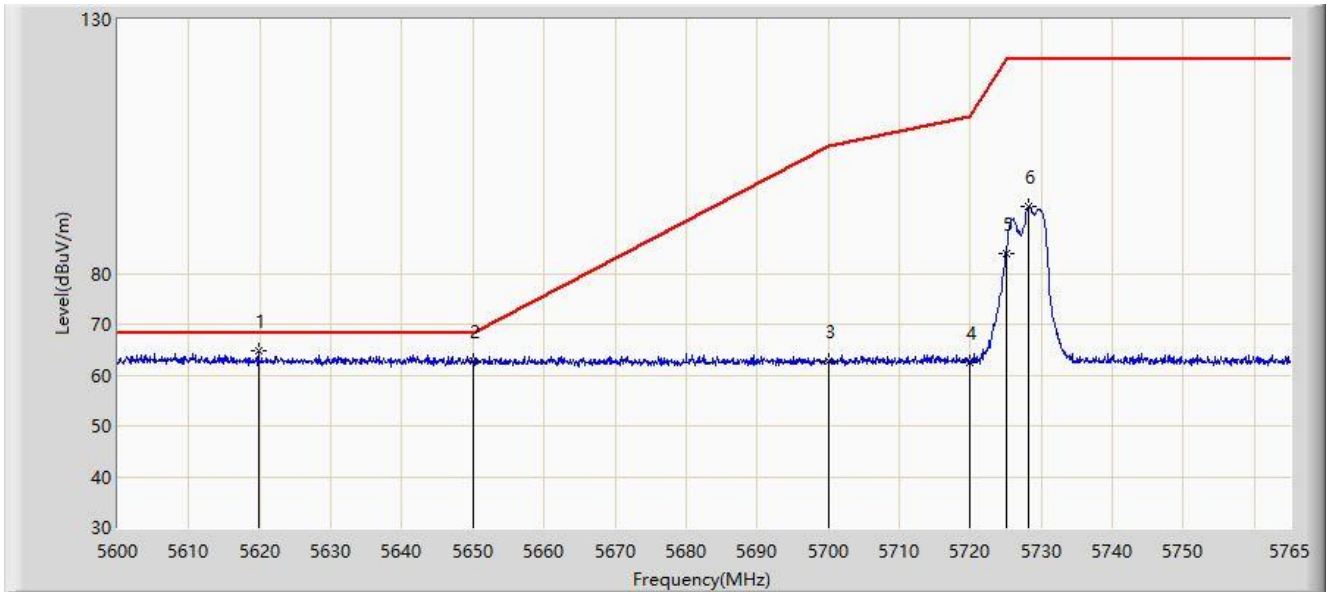

No	Flag	Mark	Frequency (MHz)	Measure Level (dBuV/m)	Reading Level (dBuV)	Margin (dB)	Limit (dBuV/m)	Factor (dB/m)	Type
1		*	5619.800	64.673	72.900	-3.527	68.200	-8.226	PK
2			5650.000	62.639	70.848	-5.561	68.200	-8.209	PK
3			5700.000	62.774	71.187	-42.426	105.200	-8.414	PK
4			5720.000	62.482	70.819	-48.318	110.800	-8.336	PK
5			5725.000	83.834	92.146	-38.366	122.200	-8.312	PK
6			5728.288	93.315	101.640	N/A	N/A	-8.324	PK

Note: Measure Level (dB μ V/m) = Reading Level (dB μ V) + Factor (dB)

Factor (dB) = Cable Loss (dB) + Antenna Factor (dB/m) - Pre_Amplifier Gain (dB).

Site: SIP-AC3	Time: 2021/08/10 - 14:44
Limit: FCC_Part15.209_RE(3m)	Engineer: Yien Qian
Probe: SIP-AC3_HF907_102861_1-18GHz	Polarity: Vertical
EUT: Wireless Guitar Pedal Receiver	Power: AC 120V/60Hz
Test Mode: Transmit by Full BW at Channel 5729MHz	

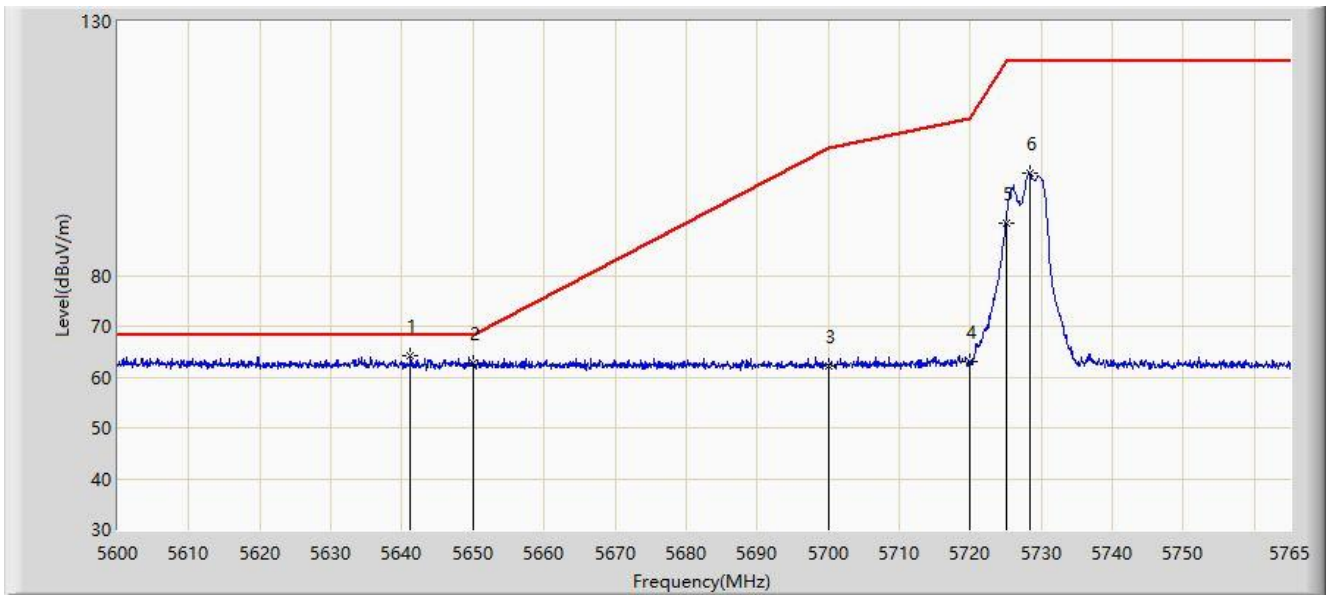

No	Flag	Mark	Frequency (MHz)	Measure Level (dBuV/m)	Reading Level (dBuV)	Margin (dB)	Limit (dBuV/m)	Factor (dB/m)	Type
1		*	5641.167	64.176	72.337	-4.024	68.200	-8.161	PK
2			5650.000	62.820	71.029	-5.380	68.200	-8.209	PK
3			5700.000	62.155	70.568	-43.045	105.200	-8.414	PK
4			5720.000	63.020	71.357	-47.780	110.800	-8.336	PK
5			5725.000	90.343	98.655	-31.857	122.200	-8.312	PK
6			5728.453	100.054	108.380	N/A	N/A	-8.326	PK

Note: Measure Level (dB μ V/m) = Reading Level (dB μ V) + Factor (dB)

Factor (dB) = Cable Loss (dB) + Antenna Factor (dB/m) - Pre_Amplifier Gain (dB).

Site: SIP-AC3	Time: 2021/08/10 - 14:53
Limit: FCC_Part15.209_RE(3m)	Engineer: Yien Qian
Probe: SIP-AC3_HF907_102861_1-18GHz	Polarity: Horizontal
EUT: Wireless Guitar Pedal Receiver	Power: AC 120V/60Hz
Test Mode: Transmit by Full BW at Channel 5846MHz	

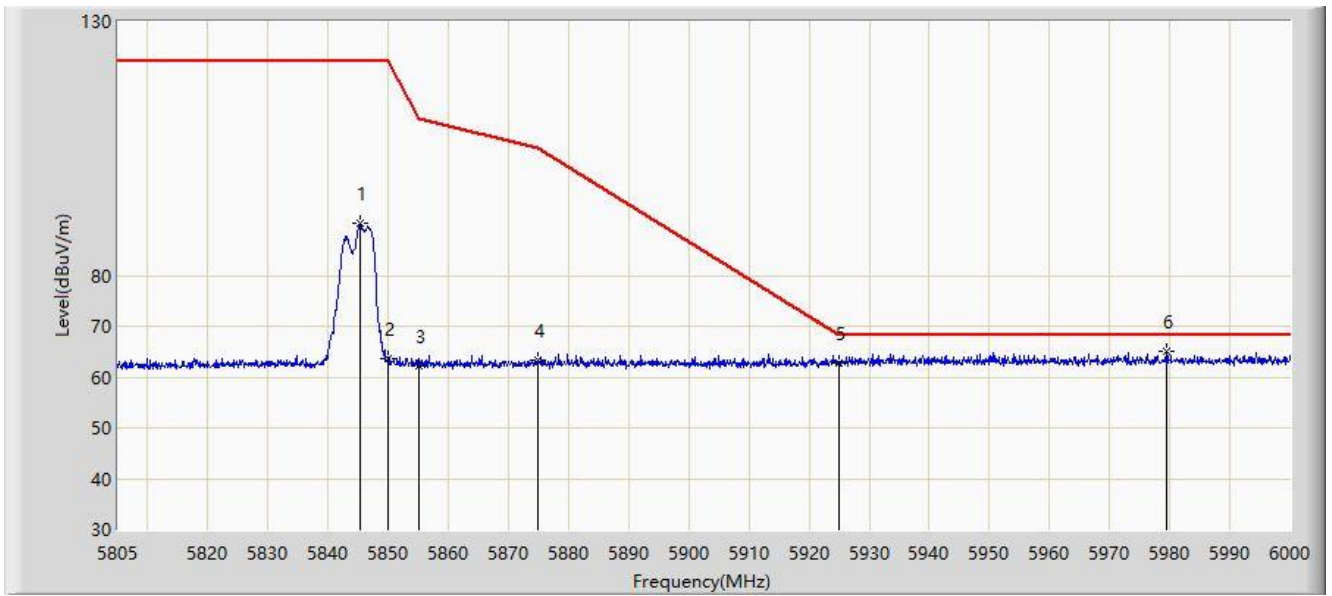

No	Flag	Mark	Frequency (MHz)	Measure Level (dBuV/m)	Reading Level (dBuV)	Margin (dB)	Limit (dBuV/m)	Factor (dB/m)	Type
1			5845.268	90.229	98.318	N/A	N/A	-8.089	PK
2			5850.000	63.512	71.616	-58.688	122.200	-8.104	PK
3			5855.000	62.257	70.377	-48.543	110.800	-8.119	PK
4			5875.000	63.405	71.398	-41.795	105.200	-7.993	PK
5			5925.000	62.743	70.549	-5.457	68.200	-7.805	PK
6		*	5979.525	65.132	72.875	-3.068	68.200	-7.742	PK

Note: Measure Level (dB μ V/m) = Reading Level (dB μ V) + Factor (dB)

Factor (dB) = Cable Loss (dB) + Antenna Factor (dB/m) - Pre_Amplifier Gain (dB).

Site: SIP-AC3	Time: 2021/08/10 - 15:04
Limit: FCC_Part15.209_RE(3m)	Engineer: Yien Qian
Probe: SIP-AC3_HF907_102861_1-18GHz	Polarity: Vertical
EUT: Wireless Guitar Pedal Receiver	Power: AC 120V/60Hz
Test Mode: Transmit by Full BW at Channel 5846MHz	

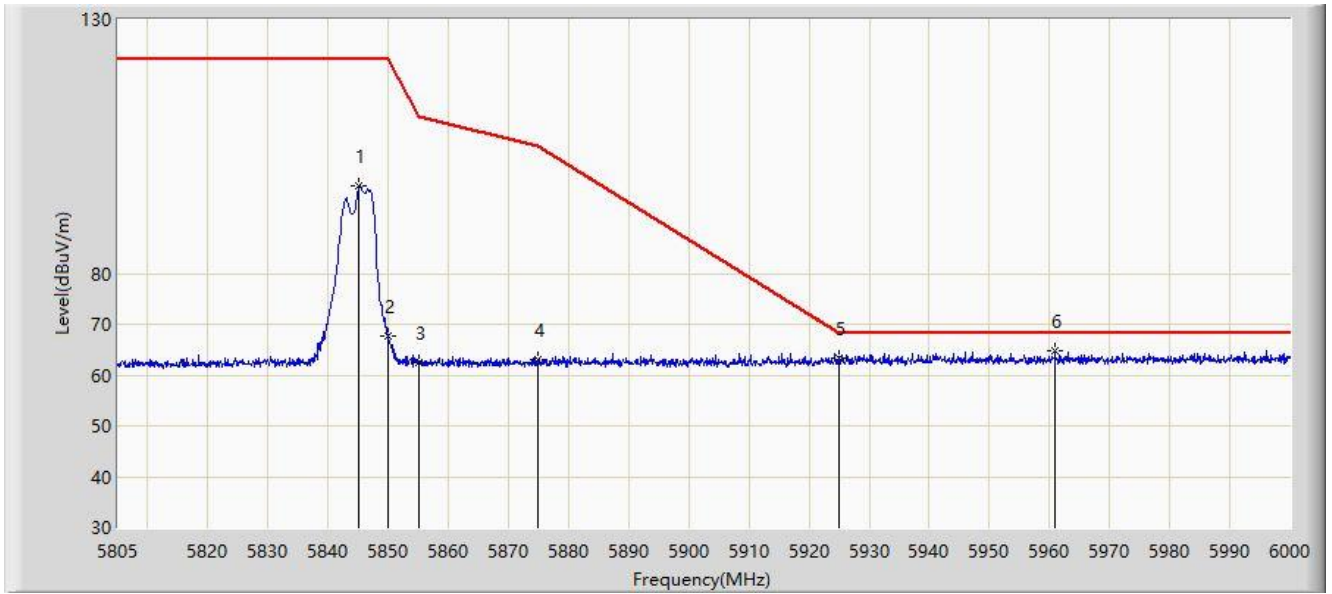

No	Flag	Mark	Frequency (MHz)	Measure Level (dBuV/m)	Reading Level (dBuV)	Margin (dB)	Limit (dBuV/m)	Factor (dB/m)	Type
1			5845.170	97.202	105.291	N/A	N/A	-8.088	PK
2			5850.000	67.606	75.710	-54.594	122.200	-8.104	PK
3			5855.000	62.547	70.667	-48.253	110.800	-8.119	PK
4			5875.000	63.027	71.020	-42.173	105.200	-7.993	PK
5			5925.000	63.222	71.028	-4.978	68.200	-7.805	PK
6		*	5960.902	64.709	72.562	-3.491	68.200	-7.853	PK

Note: Measure Level (dB μ V/m) = Reading Level (dB μ V) + Factor (dB)

Factor (dB) = Cable Loss (dB) + Antenna Factor (dB/m) - Pre_Amplifier Gain (dB).

Site: SIP-AC3	Time: 2021/08/10 - 15:13
Limit: FCC_Part15.209_RE(3m)	Engineer: Yien Qian
Probe: SIP-AC3_HF907_102861_1-18GHz	Polarity: Horizontal
EUT: Wireless Guitar Pedal Receiver	Power: AC 120V/60Hz
Test Mode: Transmit by Half BW at Channel 5729MHz	

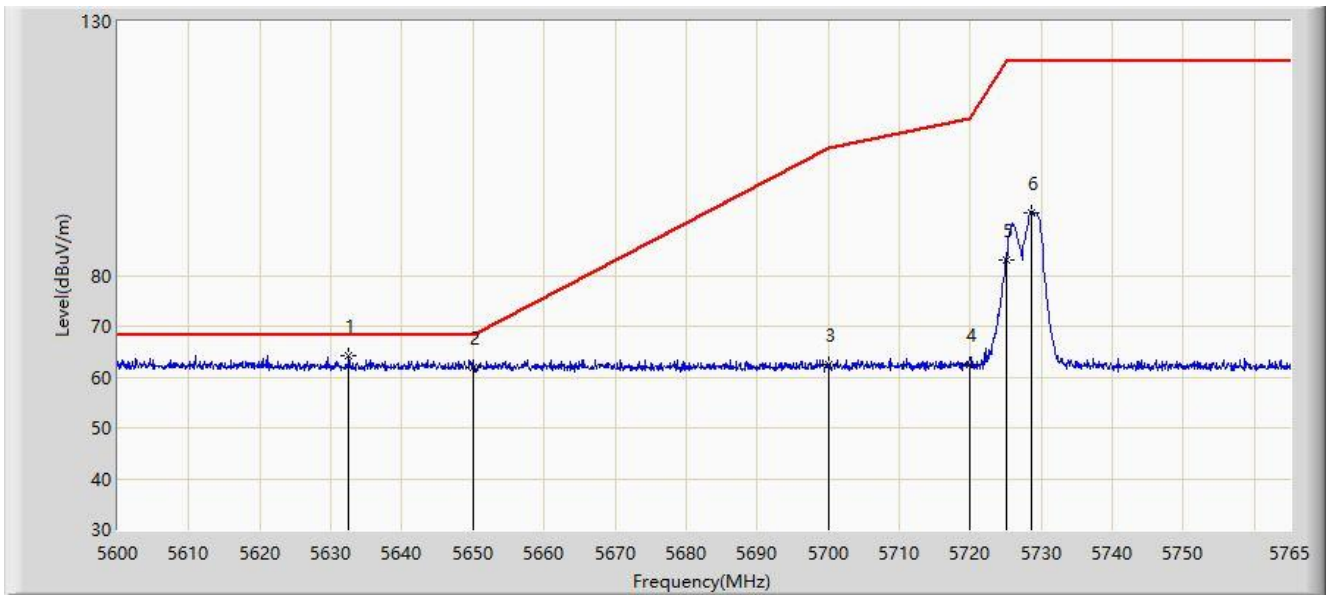

No	Flag	Mark	Frequency (MHz)	Measure Level (dBuV/m)	Reading Level (dBuV)	Margin (dB)	Limit (dBuV/m)	Factor (dB/m)	Type
1		*	5632.505	64.238	72.442	-3.962	68.200	-8.204	PK
2			5650.000	61.965	70.174	-6.235	68.200	-8.209	PK
3			5700.000	62.407	70.820	-42.793	105.200	-8.414	PK
4			5720.000	62.401	70.738	-48.399	110.800	-8.336	PK
5			5725.000	82.939	91.251	-39.261	122.200	-8.312	PK
6			5728.700	92.426	100.754	N/A	N/A	-8.328	PK

Note: Measure Level (dB μ V/m) = Reading Level (dB μ V) + Factor (dB)

Factor (dB) = Cable Loss (dB) + Antenna Factor (dB/m) - Pre_Amplifier Gain (dB).

Site: SIP-AC3	Time: 2021/08/10 - 15:17
Limit: FCC_Part15.209_RE(3m)	Engineer: Yien Qian
Probe: SIP-AC3_HF907_102861_1-18GHz	Polarity: Vertical
EUT: Wireless Guitar Pedal Receiver	Power: AC 120V/60Hz
Test Mode: Transmit by Half BW at Channel 5729MHz	

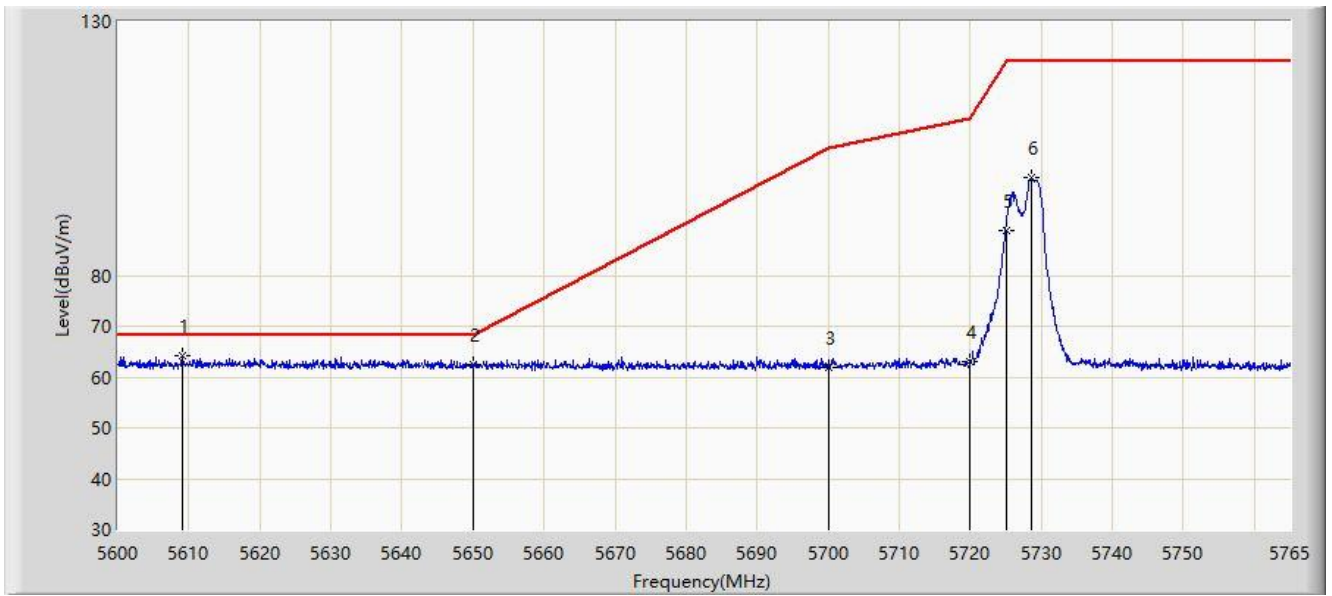

No	Flag	Mark	Frequency (MHz)	Measure Level (dBuV/m)	Reading Level (dBuV)	Margin (dB)	Limit (dBuV/m)	Factor (dB/m)	Type
1		*	5609.075	64.090	72.260	-4.110	68.200	-8.170	PK
2			5650.000	62.446	70.655	-5.754	68.200	-8.209	PK
3			5700.000	61.754	70.167	-43.446	105.200	-8.414	PK
4			5720.000	63.113	71.450	-47.687	110.800	-8.336	PK
5			5725.000	88.902	97.214	-33.298	122.200	-8.312	PK
6			5728.700	99.147	107.475	N/A	N/A	-8.328	PK

Note: Measure Level (dB μ V/m) = Reading Level (dB μ V) + Factor (dB)

Factor (dB) = Cable Loss (dB) + Antenna Factor (dB/m) - Pre_Amplifier Gain (dB).

Site: SIP-AC3	Time: 2021/08/10 - 15:25
Limit: FCC_Part15.209_RE(3m)	Engineer: Yien Qian
Probe: SIP-AC3_HF907_102861_1-18GHz	Polarity: Horizontal
EUT: Wireless Guitar Pedal Receiver	Power: AC 120V/60Hz
Test Mode: Transmit by Half BW at Channel 5846MHz	

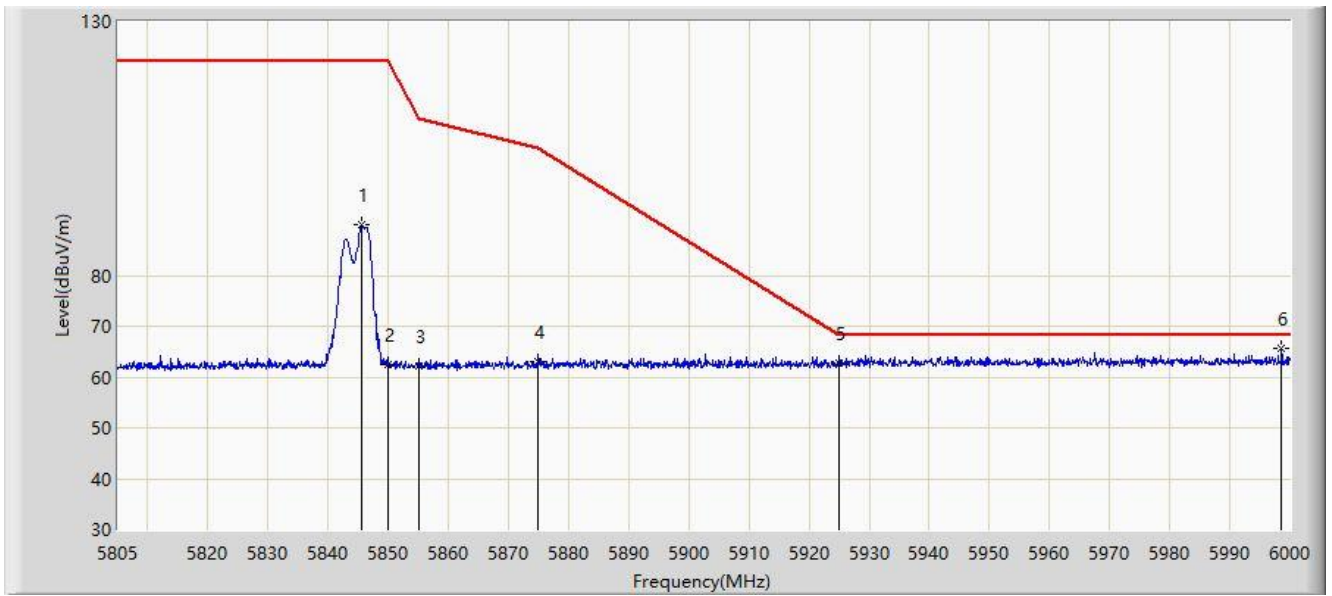

No	Flag	Mark	Frequency (MHz)	Measure Level (dBuV/m)	Reading Level (dBuV)	Margin (dB)	Limit (dBuV/m)	Factor (dB/m)	Type
1			5845.560	89.931	98.021	N/A	N/A	-8.089	PK
2			5850.000	62.439	70.543	-59.761	122.200	-8.104	PK
3			5855.000	62.111	70.231	-48.689	110.800	-8.119	PK
4			5875.000	63.077	71.070	-42.123	105.200	-7.993	PK
5			5925.000	62.774	70.580	-5.426	68.200	-7.805	PK
6		*	5998.635	65.623	73.295	-2.577	68.200	-7.673	PK

Note: Measure Level (dB μ V/m) = Reading Level (dB μ V) + Factor (dB)

Factor (dB) = Cable Loss (dB) + Antenna Factor (dB/m) - Pre_Amplifier Gain (dB).

Site: SIP-AC3	Time: 2021/08/10 - 15:29
Limit: FCC_Part15.209_RE(3m)	Engineer: Yien Qian
Probe: SIP-AC3_HF907_102861_1-18GHz	Polarity: Vertical
EUT: Wireless Guitar Pedal Receiver	Power: AC 120V/60Hz
Test Mode: Transmit by Half BW at Channel 5846MHz	

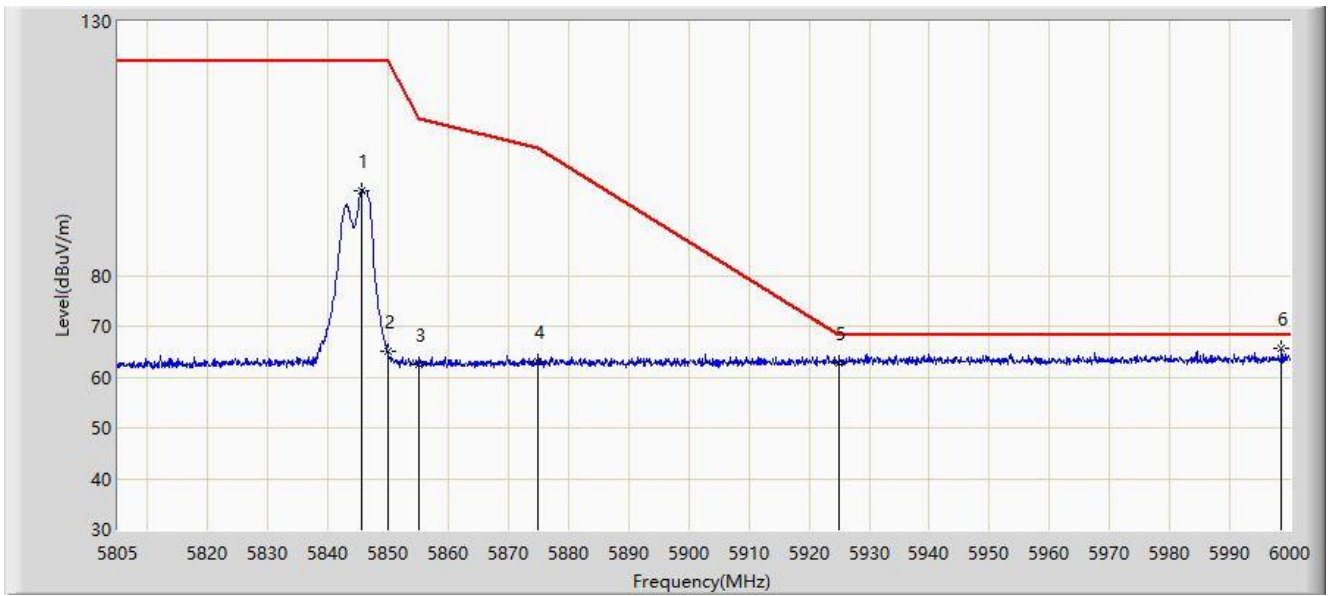

No	Flag	Mark	Frequency (MHz)	Measure Level (dBuV/m)	Reading Level (dBuV)	Margin (dB)	Limit (dBuV/m)	Factor (dB/m)	Type
1			5845.462	96.741	104.830	N/A	N/A	-8.090	PK
2			5850.000	65.015	73.119	-57.185	122.200	-8.104	PK
3			5855.000	62.346	70.466	-48.454	110.800	-8.119	PK
4			5875.000	63.077	71.070	-42.123	105.200	-7.993	PK
5			5925.000	62.845	70.651	-5.355	68.200	-7.805	PK
6		*	5998.635	65.623	73.295	-2.577	68.200	-7.673	PK

Note: Measure Level (dB μ V/m) = Reading Level (dB μ V) + Factor (dB)

Factor (dB) = Cable Loss (dB) + Antenna Factor (dB/m) - Pre_Amplifier Gain (dB).

6.9. AC Conducted Emissions Measurement

6.9.1. Test Limit

FCC Part 15 Subpart C Paragraph 15.207 Limits		
Frequency (MHz)	QP (dBuV)	AV (dBuV)
0.15 - 0.50	66 - 56	56 - 46
0.50 - 5.0	56	46
5.0 - 30	60	50

Note 1: The lower limit shall apply at the transition frequencies.

Note 2: The limit decreases linearly with the logarithm of the frequency in the range 0.15MHz to 0.5MHz.

6.9.2. Test Setup

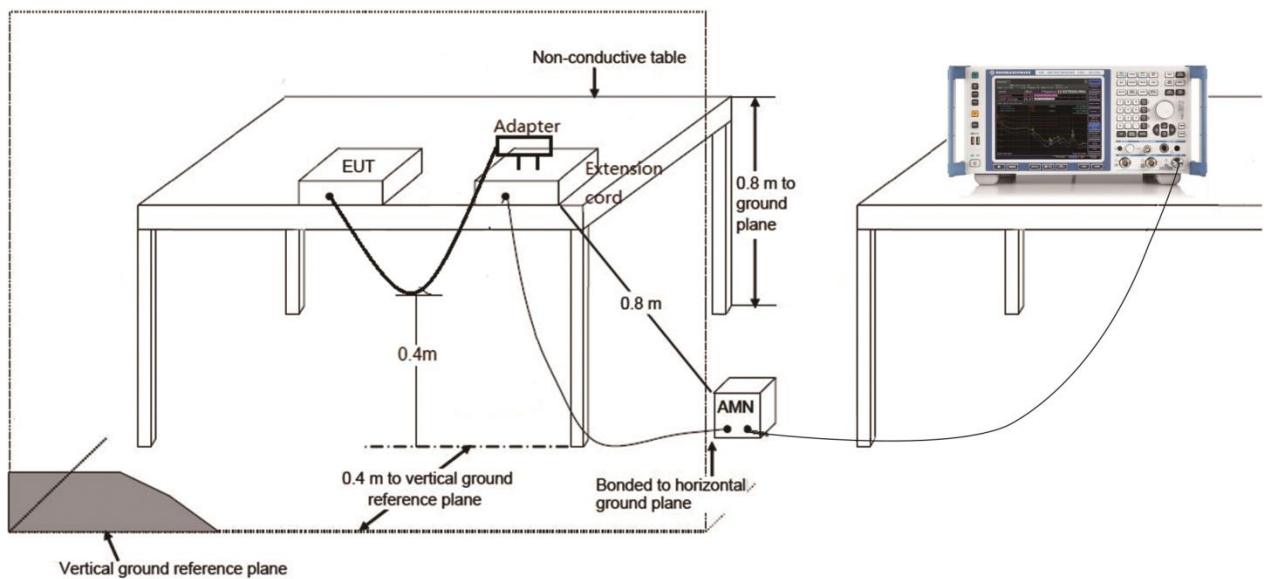

6.9.3. Test Result

Site: SIP-SR2	Time: 2021/08/18
Limit: FCC_Part15.207_CE_AC Power	Engineer: Rupert Wang
Probe: SIP-SR2-ENV216_101684_C	Polarity: Line
EUT: Wireless Guitar Pedal Receiver	Power: AC 120V/60Hz
Test Mode: Transmit	

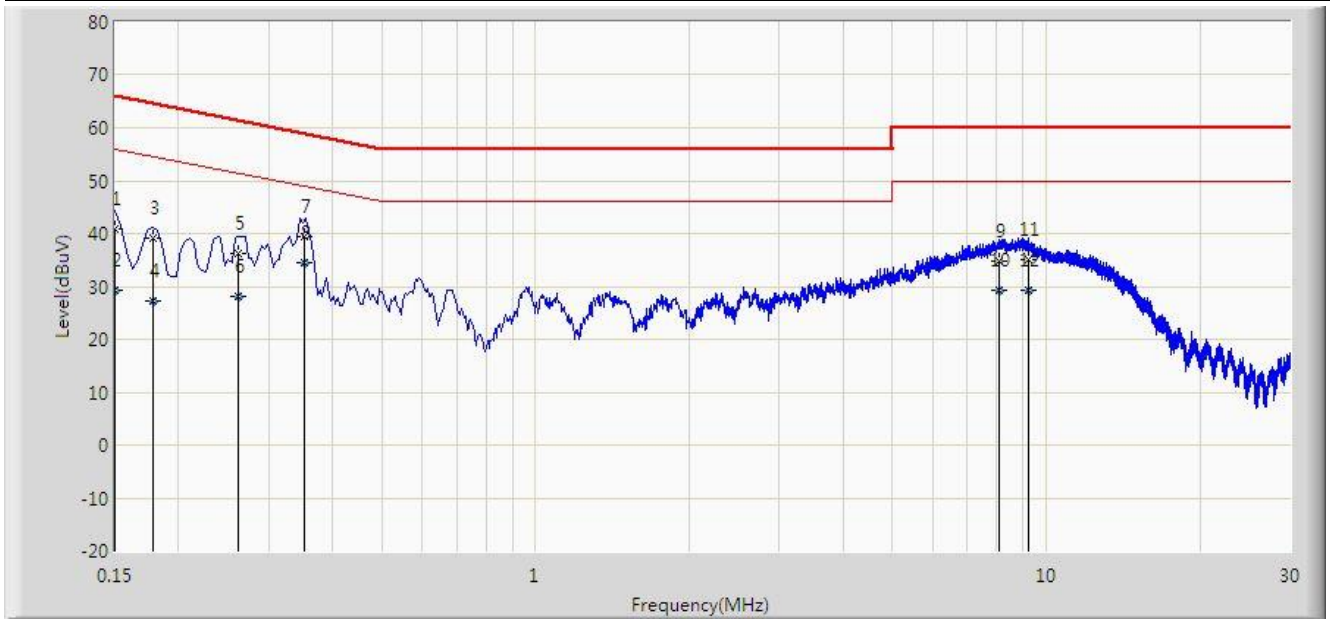

No	Flag	Mark	Frequency (MHz)	Measure Level (dBuV)	Reading Level (dBuV)	Over Limit (dB)	Limit (dBuV)	Factor (dB)	Type
1			0.150	40.766	31.116	-25.234	66.000	9.650	QP
2			0.150	29.289	19.639	-26.711	56.000	9.650	AV
3			0.178	39.134	29.490	-25.444	64.578	9.644	QP
4			0.178	27.146	17.502	-27.432	54.578	9.644	AV
5			0.262	36.293	26.593	-25.074	61.368	9.700	QP
6			0.262	28.057	18.357	-23.310	51.368	9.700	AV
7			0.353	39.412	29.700	-19.480	58.892	9.712	QP
8		*	0.353	34.412	24.700	-14.480	48.892	9.712	AV
9			8.110	34.823	24.845	-25.177	60.000	9.978	QP
10			8.110	29.410	19.432	-20.590	50.000	9.978	AV
11			9.214	35.019	25.007	-24.981	60.000	10.012	QP
12			9.214	29.329	19.317	-20.671	50.000	10.012	AV

Note: Measure Level (dB μ V) = Reading Level (dB μ V) + Factor (dB)

Factor (dB) = Cable Loss (dB) + LISN Factor (dB).

Site: SIP-SR2	Time: 2021/08/18
Limit: FCC_Part15.207_CE_AC Power	Engineer: Rupert Wang
Probe: SIP-SR2-ENV216_101684_C	Polarity: Neutral
EUT: Wireless Guitar Pedal Receiver	Power: AC 120V/60Hz
Test Mode: Transmit	

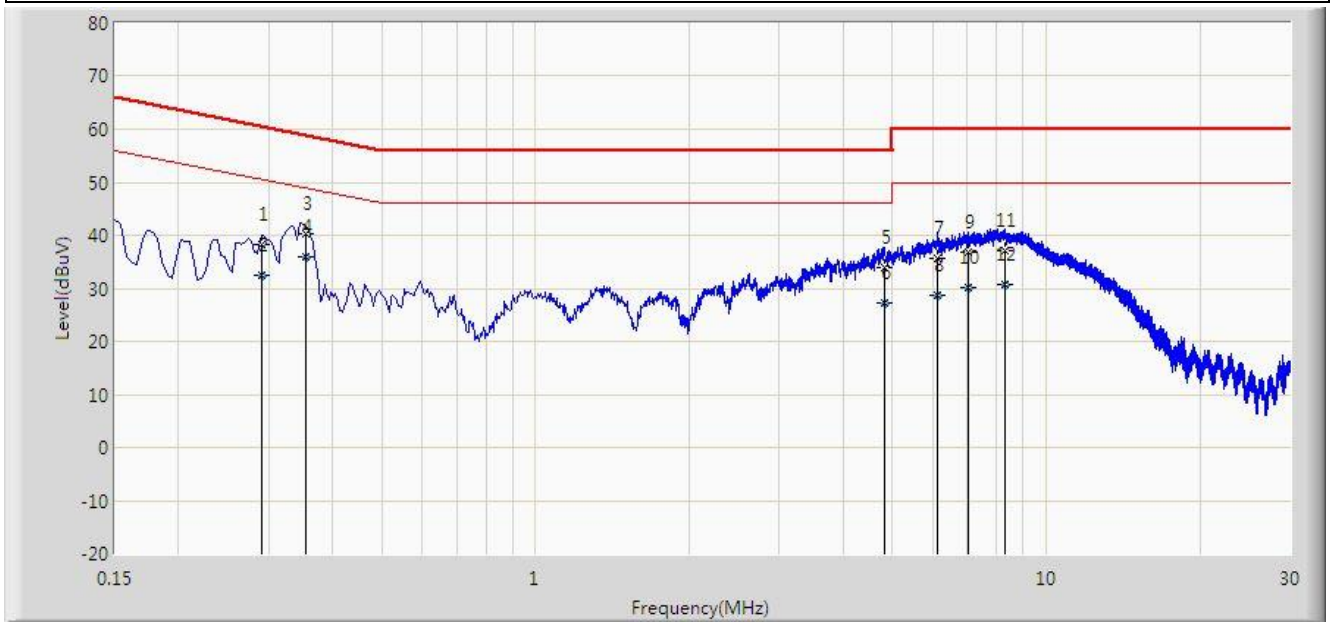

No	Flag	Mark	Frequency (MHz)	Measure Level (dBuV)	Reading Level (dBuV)	Over Limit (dB)	Limit (dBuV)	Factor (dB)	Type
1			0.290	38.286	28.589	-22.238	60.524	9.697	QP
2			0.290	32.385	22.688	-18.140	50.524	9.697	AV
3			0.354	40.402	30.700	-18.466	58.868	9.702	QP
4		*	0.354	36.002	26.300	-12.866	48.868	9.702	AV
5			4.814	33.898	24.081	-22.102	56.000	9.817	QP
6			4.814	27.138	17.321	-18.862	46.000	9.817	AV
7			6.118	35.603	25.716	-24.397	60.000	9.888	QP
8			6.118	28.802	18.915	-21.198	50.000	9.888	AV
9			7.046	36.674	26.753	-23.326	60.000	9.921	QP
10			7.046	30.010	20.089	-19.990	50.000	9.921	AV
11			8.302	37.023	27.046	-22.977	60.000	9.978	QP
12			8.302	30.790	20.813	-19.210	50.000	9.978	AV

Note: Measure Level (dBμV) = Reading Level (dBμV) + Factor (dB)

Factor (dB) = Cable Loss (dB) + LISN Factor (dB).

7. Conclusion

The data collected relate only the item(s) tested and show that the device is compliance with Part 15E of the FCC rules.

————— The End —————

Appendix A - Test Setup Photograph

Refer to "2107RSU040-UT" file.

Appendix B - EUT Photograph

Refer to "2107RSU040-UE" file.