

**CAMERA READY ARTWORK**

**PLATE NO.:** CR-3537  
**REVISION:** 00  
**ECO/PROCESS NO.:** N/A  
**DESCRIPTION:** GLXD6 Z2 Guitar Pedal Label  
**PROJECT NO.:** 17690  
**PART NO.:** 39A21312  
**SCALE:** 1:1  
**DESIGNER:** A. NARDIELLO  
**REQUESTOR:** J. LASKEY  
**DATE:** 03/05/13

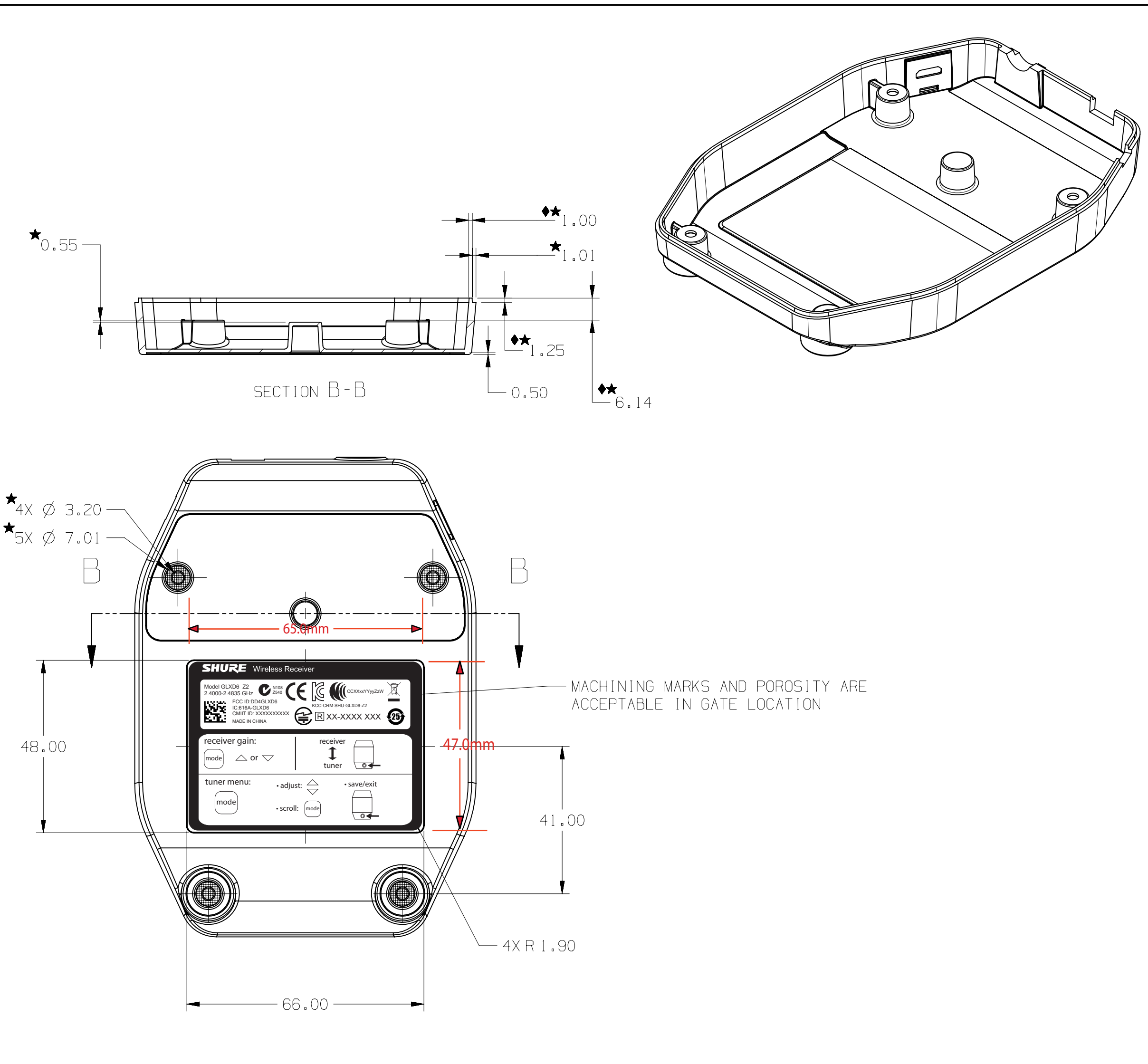
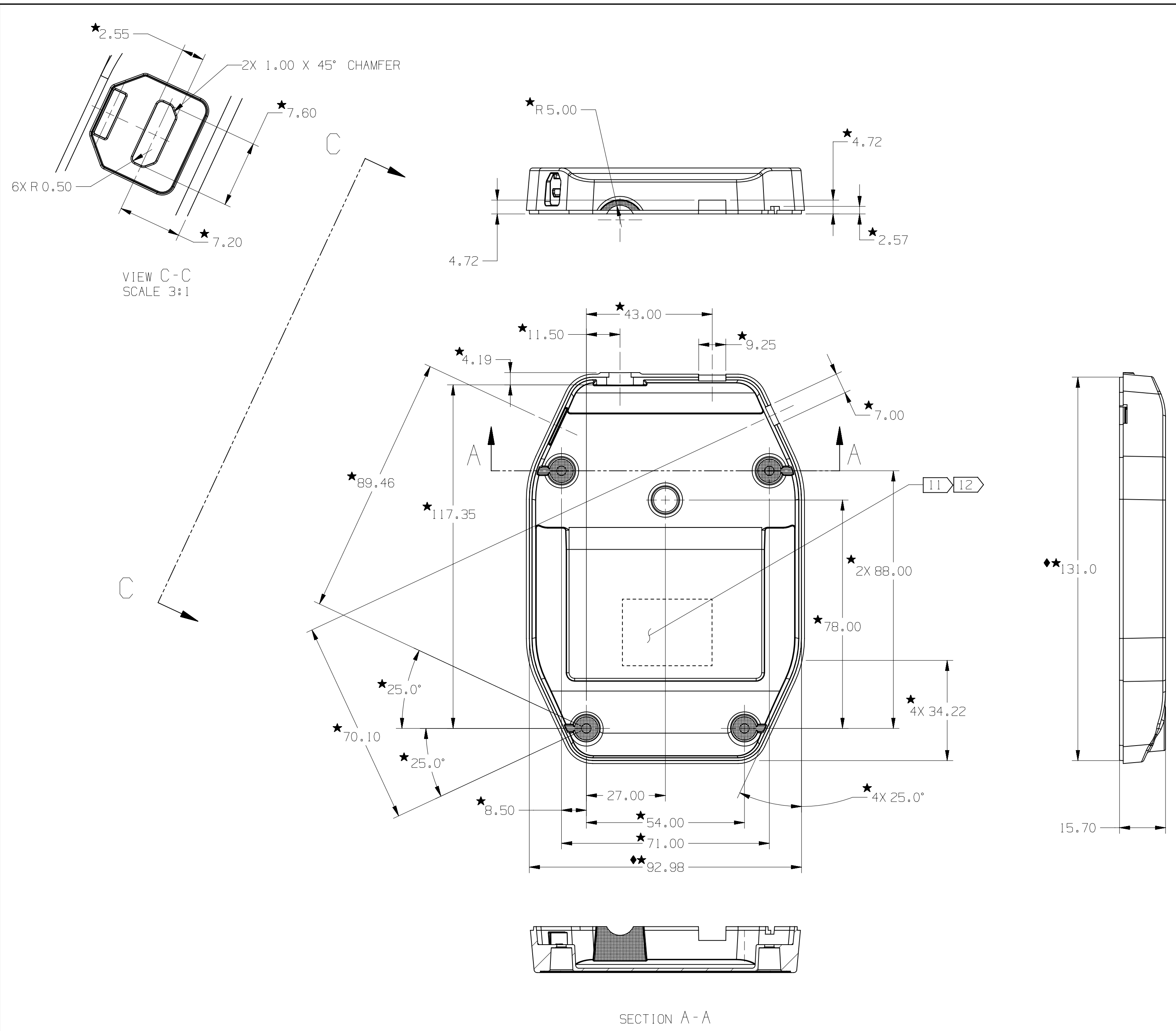

DRAWING NO: 32-20175

REVISION RECORD		
REV	DESCRIPTION OF CHANGE	DATE
00	DEVELOPMENT RELEASE FOR QUOTE	03/28/2012
01	ADDED MASKING DETAIL	04/02/2012
02	REVISED THROUGHOUT; NOTE 5, MATERIAL WAS ALUMINUM ALL DAY	05/15/2012
03	REVISED NOTE 6; POWDER COATING WAS PAINTING.	07/03/2012
04	REVISED THROUGHOUT	08/08/2012
05	REVISED THROUGHOUT DEVELOPMENT RELEASE FOR TOOLING	10/09/2012
06	REVISED DRAFT ON 3D MODEL, NO 2D DIMENSIONAL CHANGE.	10/10/2012
07	REV USB SLOT; 7.20 WAS 7.15	10/12/2012
08	REV 1/4" JACK FEATURES; REMOVED DIMS 18.00 & 10.25	10/23/2012
09	CONNECTED LABEL CUTOUT & PAD CUTOUT; NO DIMS CHANGED. ADDED GATE NOTE.	11/19/2012

NOTES UNLESS OTHERWISE SPECIFIED:

- INTERROGATE 3D CAD MODEL FOR DIMENSIONS NOT SHOWN TOLERANCES ON ALL DIMENSIONS NOT SHOWN TO BE ±.12
- FEATURE MARKED ★ IMPORTANT FOR PROPER FIT/CLEARANCE WITH MATING PART (32 PL)
- FEATURE MARKED ◆ SIGNIFICANT CHARACTERISTIC - VERIFIED BY SHURE INCORPORATED INCOMING INSPECTION DEPT (5 PL)
- MUST MEET SUPPLIER QUALITY REQUIREMENTS PER LATEST SHURE INCORPORATED INCOMING INSPECTION INSTRUCTIONS
- MATERIAL: ZAMAK #3 PER ASTM B240-07
- FINISH: ELECTROLESS NICKEL PLATE 0.005-0.008 POWDER COAT BLACK PER SHURE SPEC 4A323
- MUST BE FREE OF FLASH, SINK & OTHER SURFACE IMPERFECTIONS
- EJECTOR PIN & GATE LOCATION TO BE APPROVED BY SHURE INCORPORATED MECHANICAL ENGINEERING DEPT
- DRAFT TO BE DETERMINED BY 3D CAD MODEL
- PARTS FROM PRODUCTION MOLD MUST BE SUBMITTED TO SHURE INCORPORATED MECHANICAL ENGINEERING DEPT FOR APPROVAL PRIOR TO QUANTITY PRODUCTION
- SUPPLIER SHALL IMPRINT THIS PART WITH NO IDENTIFICATION OR MARKINGS OTHER THAN THOSE SPECIFIED
- VENDOR CODE AND PART NUMBER 3.15 HIGH CHARACTERS FLUSH TO 0.25 ABOVE SURFACE, APPLICABLE NUMBER TO BE SUPPLIED BY PURCHASING DEPARTMENT.
- MONTH/YEAR DATED CODE WHEEL TO BE SET PER MONTH AND YEAR WHEN PARTS ARE CAST.
- SUPPLIER SHALL IMPRINT THIS PART WITH NO IDENTIFICATION OR MARKINGS OTHER THAN THOSE SPECIFIED
- EXTERIOR SURFACES ARE COSMETIC. KNOCKOUTS, GATE MARKS, OVERFLOW MARKS, FLASH AND OTHER SURFACE IMPERFECTIONS ARE NOT PERMITTED.
- PART(S) TO BE PACKAGED TO AVOID DAMAGE OR DEFORMATION DURING SHIPMENT.
- SURFACES INDICATED BY CROSSHATCH ■ TO BE FREE OF POWDER COATING. ALL THREADS TO BE MASKED.

**SHURE** 5800 W TOLBY AVENUE  
NILES, IL 60714-4808  
847-800-2000  
WWW.SHURE.COM

**CONFIDENTIAL**  
© 2012-2013 SHURE INCORPORATED  
DRN: D PRATT 03/28/2012  
CHK: N/A MM/DD/YYYY  
APP: N/A MM/DD/YYYY

PART NUMBER	32A20175	3RD ANGLE	TOL: 1 PL ± 0.2 2 PL ± 0.10 ≤ ± 1.0
NOTES:	- NX CAD MODEL - DO NOT SCALE - MUST CONFORM TO ENVIRONMENTAL COMPLIANCE SPEC - 6A278 - ALL DIMENSIONS IN MM UNLESS OTHERWISE SPECIFIED		
DESCRIPTION:	CASE HALF, BOTTOM		
MATERIAL:	NOTE 4	FINISH:	NOTE 5
DWG NO:	32-20175	REV	09
PROJ:	17690	SCALE:	1 : 1
		SHEET:	1 OF 1