

MEASUREMENT REPORT

FCC PART 15C

FCC ID: DD4GLXD2Z3
Applicant: Shure Incorporated
Product: Wireless Handheld Transmitter
Model No.: GLXD2+ Z3
Trademark: 
FCC Classification: Digital Transmission System (DTS)
FCC Rule Part(s): Part 15 Subpart C (Section 15.247)
Test Procedure(s): ANSI C63.10-2013
Test Result: Complies
Test Date: July 05 ~ 15, 2021

Reviewed By:



Jame Yuan

Approved By:

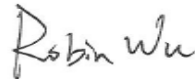

Robin Wu



The test results relate only to the samples tested.

This equipment has been shown to be capable of compliance with the applicable technical standards as indicated in the measurement report and was tested in accordance with the measurement procedures specified in ANSI C63.10-2013. Test results reported herein relate only to the item(s) tested.

The test report shall not be reproduced except in full without the written approval of MRT Technology (Suzhou) Co., Ltd.

Revision History

Report No.	Version	Description	Issue Date	Note
2106RSU074-U1	Rev. 01	Initial Report	07-23-2021	Valid

CONTENTS

Description	Page
1. General Information	5
1.1. Applicant	5
1.2. Manufacturer	5
1.3. Testing Facility	5
1.4. Equipment Description	6
1.5. Radio Specification under Test	6
1.6. Test Frequencies	6
1.7. Antennas Details	7
1.8. EMI Suppression Device(s)/Modifications	7
1.9. Test Environment Condition	7
2. Test Configuration	8
2.1. Test Mode	8
2.2. Test Setup and Software	8
2.3. Duty Cycle	9
3. ANTENNA REQUIREMENTS	10
4. TEST EQUIPMENT CALIBRATION DATE	11
5. MEASUREMENT UNCERTAINTY	14
6. TEST RESULT	15
6.1. Summary	15
6.2. 6dB Bandwidth Measurement	16
6.2.1. Test Limit	16
6.2.2. Test Procedure used	16
6.2.3. Test Setting	16
6.2.4. Test Setup	16
6.2.5. Test Result	17
6.3. Output Power Measurement	19
6.3.1. Test Limit	19
6.3.2. Test Procedure Used	19
6.3.3. Test Setting	19
6.3.4. Test Setup	20
6.3.5. Test Result	21
6.4. Power Spectral Density Measurement	22
6.4.1. Test Limit	22
6.4.2. Test Procedure Used	22

6.4.3.	Test Setting.....	22
6.4.4.	Test Setup	22
6.4.5.	Test Result.....	23
6.5.	Conducted Band Edge and Out-of-Band Emissions	25
6.5.1.	Test Limit	25
6.5.2.	Test Procedure Used	25
6.5.3.	Test Setting.....	25
6.5.4.	Test Setup	26
6.5.5.	Test Result.....	27
6.6.	Radiated Spurious Emission Measurement	32
6.6.1.	Test Limit	32
6.6.2.	Test Procedure Used	32
6.6.3.	Test Setting.....	32
6.6.4.	Test Setup	34
6.6.5.	Test Result.....	35
6.7.	Radiated Restricted Band Edge Measurement.....	43
6.7.1.	Test Limit	43
6.7.2.	Test Procedure Used	44
6.7.3.	Test Setting.....	44
6.7.4.	Test Setup	45
6.7.5.	Test Result.....	46
6.8.	AC Conducted Emissions Measurement	62
6.8.1.	Test Limit	62
6.8.2.	Test Setup	62
6.8.3.	Test Result.....	63
7.	CONCLUSION	65
	Appendix A - Test Setup Photograph	66
	Appendix B - EUT Photograph.....	67

1.4. Equipment Description

Product Name	Wireless Handheld Transmitter
Model No.	GLXD2+ Z3
Serial No.	3AD15443973
Radio Specification	2.4GHz & 5.8GHz
Antenna Specification	Refer to clause 1.7
Operating Temperature	0 ~ 45 °C
Power Type	AC/DC Adapter or Rechargeable Li-ion Battery Input
Accessories	
AC/DC Adapter	Model No.: SBC10-USB15WSUSTWJ Input: 100 ~ 240V, 50/60Hz, 0.6A Output: 5.0V=3.0A, 15.0W Max
Rechargeable Li-ion Battery	Model No.: SB904 Capacitance: 2420mAh/8.71Wh Rated Voltage: 3.6V

Note: The information of EUT was provided by the manufacturer, and the accuracy of the information shall be the responsibility of the manufacturer.

1.5. Radio Specification under Test

Frequency Range	2404 ~ 2478MHz
Declared Channel Bandwidth	Full Bandwidth Mode: 2 MHz Half Bandwidth Mode: 1 MHz
Channel Number	36
Channel Spacing	1MHz
Type of Modulation	2-level CPM with Gaussian shaping (basically GFSK)

1.6. Test Frequencies

Frequency Bands (MHz)	Test Frequency (MHz)		
	Lowest	Middle	Highest
2404 ~ 2478	2404	2442	2478

Note: Detail working frequencies refer to operation description.

1.7. Antennas Details

Antenna Type	Frequency Band (MHz)	Max Peak Gain (dBi)
Monopole Antenna	2404	4.71
	2442	4.87
	2478	5.18

1.8. EMI Suppression Device(s)/Modifications

No EMI suppression device(s) were added and/or no modifications were made during testing.

1.9. Test Environment Condition

Ambient Temperature	15 ~ 35 °C
Relative Humidity	20 ~ 75 %RH

2. Test Configuration

2.1. Test Mode

Test Mode	Mode 1: Transmit by Full BW
	Mode 2: Transmit by Half BW

Note: Bandwidth abbreviation is BW.

2.2. Test Setup and Software

The device was tested per the guidance ANSI C63.10: 2013 that was used to reference the appropriate EUT setup for radiated spurious emissions and AC line conducted emission testing.

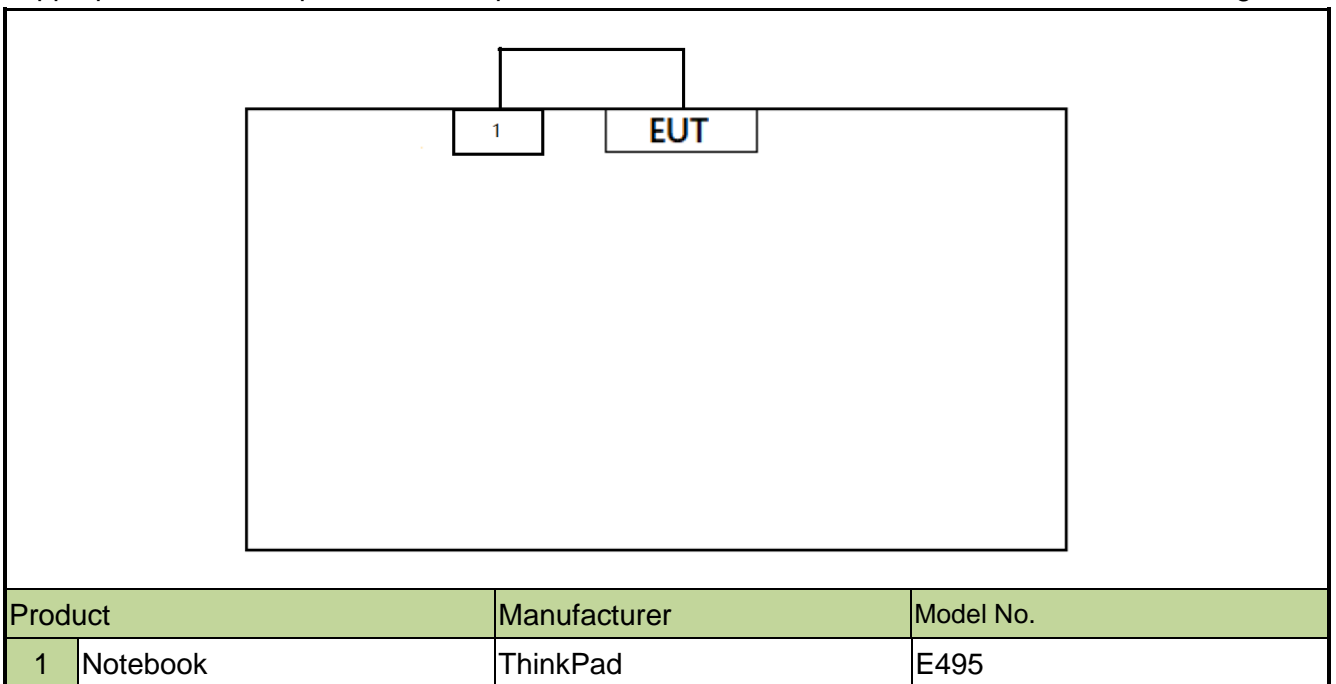

Note 1: The test utility software used during testing was "ttermpro.exe", and the version was 4.78.

Note 2: Detail power setting refer to operation description.

2.3. Duty Cycle

The maximum achievable duty cycles for all modes were determined based on measurements performed on a spectrum analyzer in zero-span mode with RBW = 8MHz, VBW = 50MHz. The RBW and VBW were both greater than 50/T, where T is the minimum transmission duration, and the number of sweep points across T was greater than 100. The duty cycles are as follows:

Test Mode	Duty Cycle (%)
Full BW	59.39
Half BW	79.38

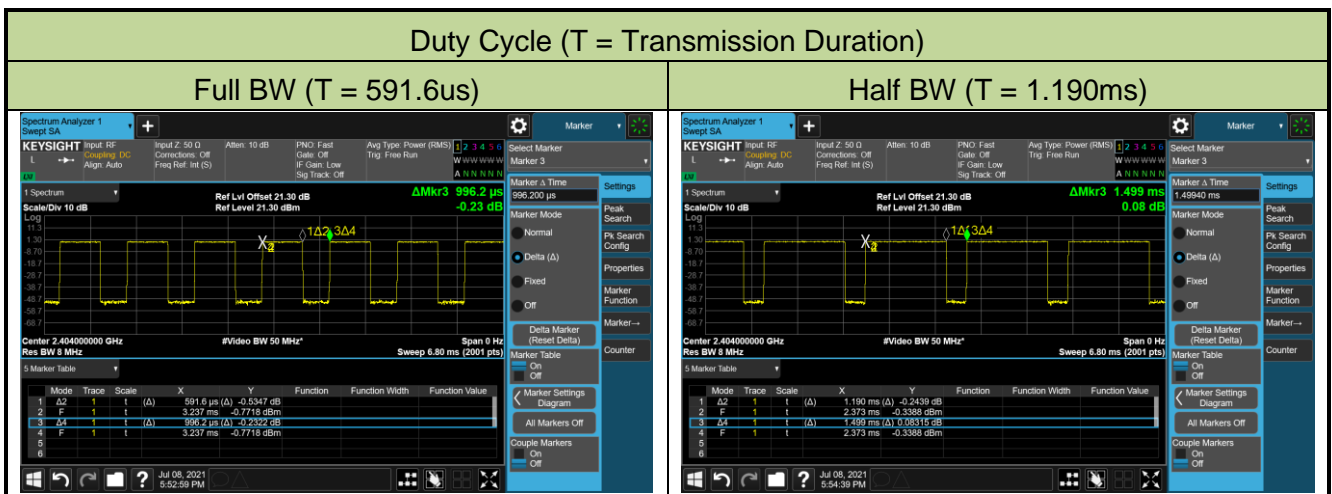

3. ANTENNA REQUIREMENTS

Excerpt from §15.203 of the FCC Rules/Regulations:

“An intentional radiator antenna shall be designed to ensure that no antenna other than that furnished by the responsible party can be used with the device. The use of a permanently attached antenna or of an antenna that uses a unique coupling to the intentional radiator shall be considered sufficient to comply with the provisions of this section.”

- The antenna of the device is **permanently attached**.
- There are no provisions for connection to an external antenna.

Conclusion:

The unit complies with the requirement of §15.203.

4. TEST EQUIPMENT CALIBRATION DATE

Conducted Emission (WZ-SR2)

Instrument	Manufacturer	Type No.	Asset No.	Cali. Interval	Cali. Due Date
EMI Test Receiver	R&S	ESR3	MRTSUE06909	1 year	2021/11/22
Two-Line V-Network	R&S	ENV216	MRTSUE06002	1 year	2022/06/08
Thermal Hygrometer	testo	608-H1	MRTSUE06404	1 year	2022/06/28
Shielding Room	MIX-BEP	Chamber-SR2	MRTSUE06215	N/A	N/A

Conducted Emission (SIP-SR2)

Instrument	Manufacturer	Type No.	Asset No.	Cali. Interval	Cali. Due Date
EMI Test Receiver	R&S	ESR3	MRTSUE06613	1 year	2022/06/24
Two-Line V-Network	R&S	ENV216	MRTSUE06003	1 year	2022/06/08
Thermal Hygrometer	testo	608-H1	MRTSUE06621	1 year	2021/12/03

Radiated Emission (WZ-AC1)

Instrument	Manufacturer	Type No.	Asset No.	Cali. Interval	Cali. Due Date
EMI Test Receiver	R&S	ESR7	MRTSUE06001	1 year	2022/01/04
Loop Antenna	Schwarzbeck	FMZB 1519	MRTSUE06025	1 year	2021/11/08
Bilog Period Antenna	Schwarzbeck	VULB 9168	MRTSUE06172	1 year	2021/08/08
Horn Antenna	Schwarzbeck	BBHA 9120D	MRTSUE06023	1 year	2021/09/27
Horn Antenna	Schwarzbeck	BBHA9170	MRTSUE06597	1 year	2021/12/14
Microwave System Amplifier	Agilent	83017A	MRTSUE06076	1 year	2021/11/14
Preamplifier	Schwarzbeck	BBV 9721	MRTSUE06121	1 year	2022/06/09
Thermal Hygrometer	testo	608-H1	MRTSUE06403	1 year	2022/06/28
Anechoic Chamber	TDK	Chamber-AC1	MRTSUE06212	1 year	2022/04/29

Radiated Emission (WZ-AC2)

Instrument	Manufacturer	Type No.	Asset No.	Cali. Interval	Cali. Due Date
MXE EMI Receiver	Keysight	N9038A	MRTSUE06125	1 year	2022/06/24
Loop Antenna	Schwarzbeck	FMZB 1519	MRTSUE06025	1 year	2021/11/08
Bilog Period Antenna	Schwarzbeck	VULB 9162	MRTSUE06022	1 year	2022/05/24
Broad-Band Horn Antenna	Schwarzbeck	BBHA 9120D	MRTSUE06171	1 year	2021/10/25
Horn Antenna	Schwarzbeck	BBHA9170	MRTSUE06597	1 year	2021/12/14
Broadband Coaxial Preamplifier	Schwarzbeck	BBV 9718	MRTSUE06176	1 year	2021/11/14
Thermal Hygrometer	Minggao	ETH529	MRTSUE06170	1 year	2021/12/08
Anechoic Chamber	RIKEN	Chamber-AC2	MRTSUE06213	1 year	2022/04/29

Radiated Emission (SIP-AC1)

Instrument	Manufacturer	Type No.	Asset No.	Cali. Interval	Cali. Due Date
EMI Test Receiver	R&S	ESR3	MRTSUE06612	1 year	2022/06/24
EXA Signal Analyzer	Keysight	N9010B	MRTSUE06559	1 year	2022/06/24
Loop Antenna	Schwarzbeck	FMZB 1519 B	MRTSUE06937	1 year	2022/03/09
Bilog Period Antenna	Schwarzbeck	VULB9168	MRTSUE06645	1 year	2021/08/30
Double Ridged Horn Antenna	R&S	HF907	MRTSUE06610	1 year	2021/08/30
Preamplifier	EMCI	EMC051845SE	MRTSUE06600	1 year	2021/11/09
Thermal Hygrometer	testo	608-H1	MRTSUE06620	1 year	2021/12/03
Anechoic Chamber	RIKEN	SIP-AC1	MRTSUE06554	1 year	2021/12/24

Radiated Emission (SIP-AC2)

Instrument	Manufacturer	Type No.	Asset No.	Cali. Interval	Cali. Due Date
EMI Test Receiver	R&S	ESR3	MRTSUE06613	1 year	2022/06/24
MXA Signal Analyzer	Keysight	N9020B	MRTSUE06604	1 year	2021/09/26
Loop Antenna	Schwarzbeck	FMZB 1519 B	MRTSUE06937	1 year	2022/03/09
Bilog Period Antenna	Schwarzbeck	VULB9168	MRTSUE06646	1 year	2021/08/30
Horn Antenna	Schwarzbeck	BBHA9120D	MRTSUE06648	1 year	2021/11/26
Horn Antenna	Schwarzbeck	BBHA9170	MRTSUE06599	1 year	2021/11/26
Preamplifier	EMCI	EMC051845SE	MRTSUE06644	1 year	2021/11/09
Preamplifier	EMCI	EMC184045SE	MRTSUE06602	1 year	2021/10/12
Thermal Hygrometer	testo	608-H1	MRTSUE06624	1 year	2021/12/03
Anechoic Chamber	RIKEN	SIP-AC2	MRTSUE06781	1 year	2021/12/24

Radiated Emission (SIP-AC3)

Instrument	Manufacturer	Type No.	Asset No.	Cali. Interval	Cali. Due Date
Preamplifier	Schwarzbeck	BBV 9721	MRTSUE06121	1 year	2022/06/09
EMI Test Receiver	R&S	ESR3	MRTSUE06612	1 year	2022/06/24
EXA Signal Analyzer	Keysight	N9010B	MRTSUE06559	1 year	2022/06/24
Loop Antenna	Schwarzbeck	FMZB 1519	MRTSUE06025	1 year	2021/11/08
Bilog Period Antenna	Schwarzbeck	VULB9168	MRTSUE06646	1 year	2021/08/30
Double Ridged Horn Antenna	R&S	HF907	MRTSUE06611	1 year	2021/09/13
Horn Antenna	Schwarzbeck	BBHA9170	MRTSUE06598	1 year	2021/11/26
Preamplifier	EMCI	EMC012645SE	MRTSUE06642	1 year	2022/01/14
Thermal Hygrometer	testo	608-H1	MRTSUE06622	1 year	2021/12/03
Anechoic Chamber	RIKEN	SIP-AC3	MRTSUE06782	1 year	2021/12/24

Conducted Test Equipment (WZ-TR3)

Instrument	Manufacturer	Type No.	Asset No.	Cali. Interval	Cali. Due Date
EXA Signal Analyzer	Agilent	N9020A	MRTSUE06106	1 year	2022/04/13
EXA Signal Analyzer	Keysight	N9010B	MRTSUE06607	1 year	2022/01/06
Power Meter	Agilent	U2021XA	MRTSUE06030	1 year	2021/10/22
USB wideband power sensor	Keysight	U2021XA	MRTSUE06446	1 year	2022/06/08
USB wideband power sensor	Keysight	U2021XA	MRTSUE06447	1 year	2022/06/08
Bluetooth Test Set	Anritsu	MT8852B-042	MRTSUE06389	1 year	2022/06/08
Modulation Analyzer	HP	HP8901A	MRTSUE06098	1 year	2021/09/26
DC Power Supply	GWINSTEK	DPS-3303C	MRTSUE06064	N/A	N/A
Temperature & Humidity Chamber	BAOYT	BYH-150CL	MRTSUE06051	1 year	2021/10/22
Thermal Hygrometer	testo	608-H1	MRTSUE06401	1 year	2022/06/28

Conducted Test Equipment (SIP-TR1)

Instrument	Manufacturer	Type No.	Asset No.	Cali. Interval	Cali. Due Date
EXA Signal Analyzer	KEYSIGHT	N9010B	MRTSUE06603	1 year	2021/11/23
PXA Signal Analyzer	Keysight	N9030B	MRTSUE06395	1 year	2021/08/30
USB wideband power sensor	Agilent	U2021XA	MRTSUE06595	1 year	2021/09/26
USB wideband power sensor	Agilent	U2021XA	MRTSUE06596	1 year	2021/09/26
Temperature Chamber	BAOYT	BYG-408CS	MRTSUE06847	1 year	2022/02/23
Thermal Hygrometer	testo	608-H1	MRTSUE11022	1 year	2021/11/25

Software	Version	Function
EMI Software	V3	EMI Test Software

5. MEASUREMENT UNCERTAINTY

Where relevant, the following test uncertainty levels have been estimated for tests performed on the EUT as specified in CISPR 16-4-2. This uncertainty represents an expanded uncertainty expressed at approximately the 95% confidence level using a coverage factor of $k = 2$.

AC Conducted Emission Measurement
Measurement Uncertainty for a Level of Confidence of 95% ($U=2Uc(y)$): 9kHz~150kHz: 3.74dB 150kHz~30MHz: 3.44dB
Radiated Disturbance
Measurement Uncertainty for a Level of Confidence of 95% ($U=2Uc(y)$): Horizontal: 9kHz~300MHz: 5.04dB 300MHz~1GHz: 4.95dB 1GHz~40GHz: 6.40dB Vertical: 9kHz~300MHz: 5.24dB 300MHz~1GHz: 6.03dB 1GHz~40GHz: 6.40dB
Spurious Emissions, Conducted
Measuring Uncertainty for a Level of Confidence of 95% ($U=2Uc(y)$): 0.78dB
Output Power
Measuring Uncertainty for a Level of Confidence of 95% ($U=2Uc(y)$): 1.13dB
Power Spectrum Density
Measuring Uncertainty for a Level of Confidence of 95% ($U=2Uc(y)$): 1.15dB
Occupied Bandwidth
Measuring Uncertainty for a Level of Confidence of 95% ($U=2Uc(y)$): 0.28%

6. TEST RESULT

6.1. Summary

FCC Part Section(s)	Test Description	Test Limit	Test Condition	Test Result	Reference
15.247(a)(2)	6dB Bandwidth	$\geq 500\text{kHz}$	Conducted	Pass	Section 6.2
15.247(b)(3)	Output Power	$\leq 1\text{Watt}$		Pass	Section 6.3
15.247(e)	Power Spectral Density	$\leq 8\text{dBm} / 3\text{kHz}$		Pass	Section 6.4
15.247(d)	Band Edge / Out-of-Band Emissions	$\geq 20\text{dBc (Peak)}$		Pass	Section 6.5
15.205 15.209	General Field Strength (Restricted Bands and Radiated Emission)	Emissions in restricted bands must meet the radiated limits detailed in 15.209	Radiated	Pass	Section 6.6 & 6.7
15.207	AC Conducted Emissions 150kHz - 30MHz	$< \text{FCC 15.207 limits}$	Line Conducted	Pass	Section 6.8

Notes:

- 1) The analyzer plots shown in this section were all taken with a correction table loaded into the analyzer. The correction table was used to account for the losses of the cables and attenuators used as part of the system to connect the EUT to the analyzer at all frequencies of interest.
- 2) All modes of operation and data rates were investigated. For radiated emission test, every axis (X, Y, Z) was also verified. The test results shown in the following sections represent the worst case emissions.

6.2. 6dB Bandwidth Measurement

6.2.1. Test Limit

The minimum 6dB bandwidth shall be at least 500 kHz.

6.2.2. Test Procedure used

ANSI C63.10-2013 - Section 11.8

6.2.3. Test Setting

1. The Spectrum's automatic bandwidth measurement capability was used to perform the 6dB bandwidth measurement. The "X" dB bandwidth parameter was set to $X = 6$. The bandwidth measurement was not influenced by any intermediate power nulls in the fundamental emission.
2. Set RBW = 100 kHz
3. $VBW \geq 3 \times RBW$
4. Detector = Peak
5. Trace mode = Max hold
6. Sweep = Auto couple
7. Allow the trace was allowed to stabilize

6.2.4. Test Setup

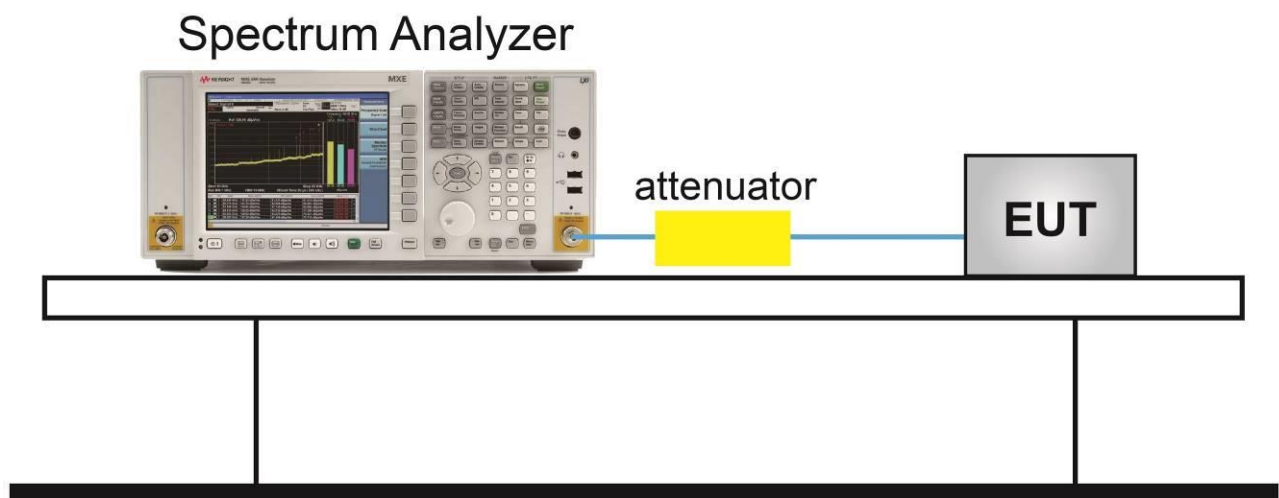

6.2.5. Test Result

Test Site	SIP-TR1	Test Engineer	Alisa Deng
Test Date	2021/07/08		

Test Mode	Frequency (MHz)	6dB Bandwidth (MHz)	Limit (MHz)	Result
Full BW	2404	1.879	≥ 0.5	Pass
Full BW	2442	2.030	≥ 0.5	Pass
Full BW	2478	2.017	≥ 0.5	Pass
Half BW	2404	1.016	≥ 0.5	Pass
Half BW	2442	1.028	≥ 0.5	Pass
Half BW	2478	1.034	≥ 0.5	Pass



Half BW 6dB Bandwidth

2404MHz



2442MHz



2478MHz

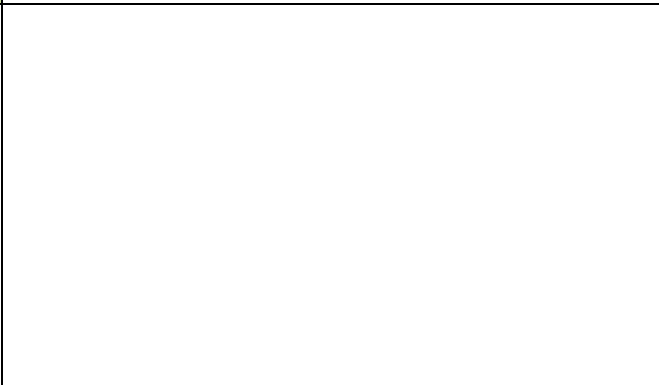

6.3. Output Power Measurement

6.3.1. Test Limit

The maximum out power shall be less 1 Watt (30dBm).

The conducted output power limit specified in paragraph FCC Part 15.247(b) of this section is based on the use of antennas with directional gains that do not exceed 6 dBi. If transmitting antennas of directional gain greater than 6 dBi are used, the conducted output power from the intentional radiator shall be reduced below the stated values in paragraphs FCC Part 15.247(b)(3) of this section, as appropriate, by the amount in dB that the directional gain of the antenna exceeds 6 dBi.

6.3.2. Test Procedure Used

ANSI C63.10-2013 Section 11.9.1.3

ANSI C63.10-2013 Section 11.9.2.3

6.3.3. Test Setting

Method PKPM1 (Peak Power Measurement of Signals with DTS BW \leq 50MHz)

Peak power measurements were performed only when the EUT was transmitting at its maximum power control level using a broadband power meter with a pulse sensor. The pulse sensor employs a VBW = 50MHz so this method was only used for signals whose DTS bandwidth was less than or equal to 50MHz.

Average Power Measurement

Average power measurements were performed only when the EUT was transmitting at its maximum power control level using a broadband power meter with a pulse sensor. The power meter implemented triggering and gating capabilities which were set up such that power measurements were recorded only during the ON time of the transmitter.

6.3.4. Test Setup

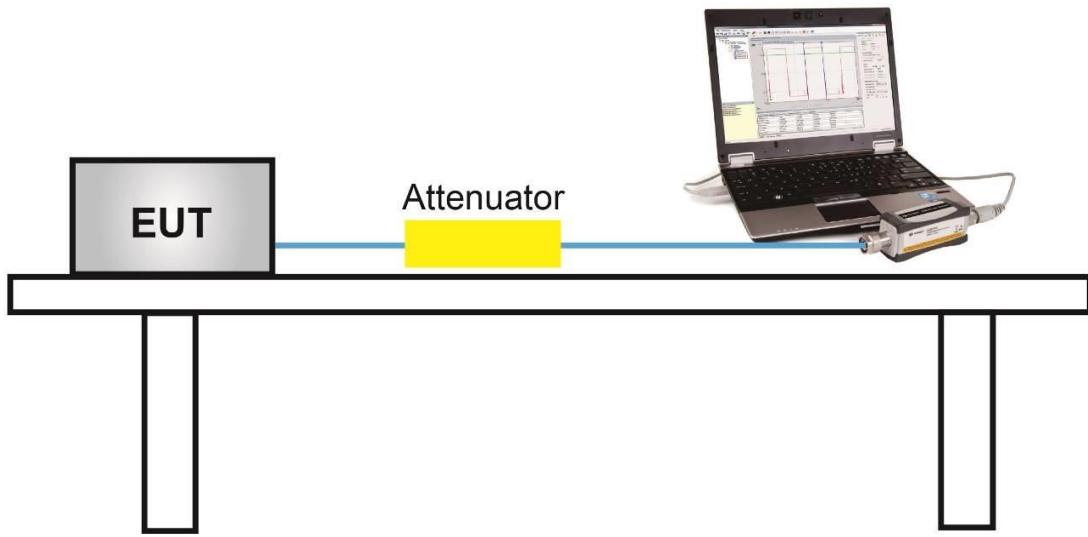

6.3.5. Test Result

Test Site	SIP-TR1	Test Engineer	Alisa Deng
Test Date	2021/07/05		

Test Mode	Freq. (MHz)	Peak Power (dBm)	Limit (dBm)	Result
Full BW	2404	1.64	≤ 30.00	Pass
Full BW	2442	1.81	≤ 30.00	Pass
Full BW	2478	1.73	≤ 30.00	Pass
Half BW	2404	1.63	≤ 30.00	Pass
Half BW	2442	1.48	≤ 30.00	Pass
Half BW	2478	1.67	≤ 30.00	Pass

Test Result of Average Output Power (Reporting Only)

Test Mode	Freq. (MHz)	Average Power (dBm)	Limit (dBm)	Result
Full BW	2404	-0.26	≤ 30.00	Pass
Full BW	2442	-0.14	≤ 30.00	Pass
Full BW	2478	-0.27	≤ 30.00	Pass
Half BW	2404	-0.54	≤ 30.00	Pass
Half BW	2442	-0.31	≤ 30.00	Pass
Half BW	2478	-0.21	≤ 30.00	Pass

6.4. Power Spectral Density Measurement

6.4.1. Test Limit

The maximum permissible power spectral density is 8dBm in any 3 kHz band.

The same method of determining the conducted output power shall be used to determine the power spectral density.

6.4.2. Test Procedure Used

ANSI C63.10-2013 - Section 11.10.2

6.4.3. Test Setting

1. Analyzer was set to the center frequency of the DTS channel under investigation
2. Span ≥ 1.5 times the OBW
3. RBW = 3kHz
4. VBW = 10kHz
5. Detector = Peak
6. Sweep time = auto couple
7. Trace mode = max hold
8. Trace was allowed to stabilize

6.4.4. Test Setup

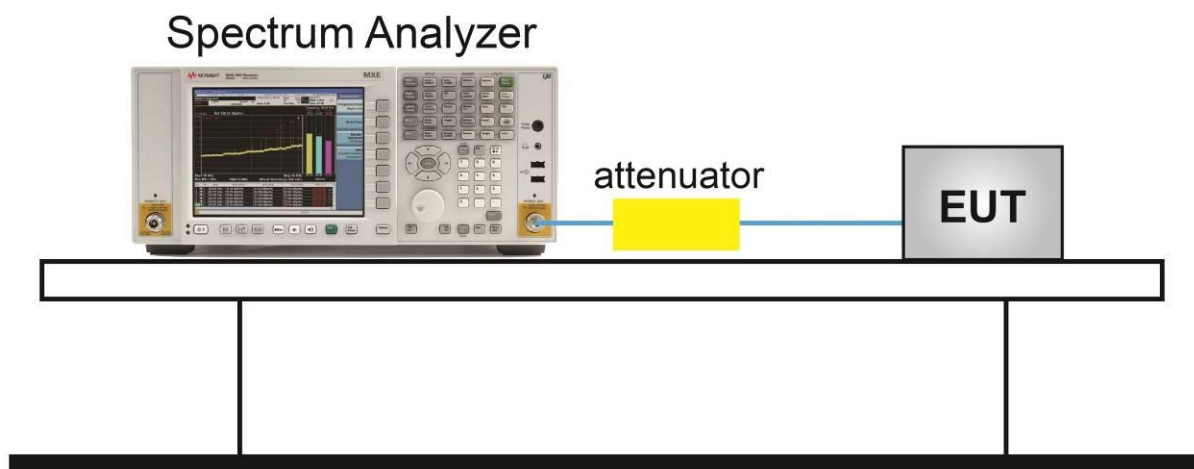

6.4.5. Test Result

Test Site	SIP-TR1	Test Engineer	Alisa Deng
Test Date	2021/07/08		

Test Mode	Freq. (MHz)	PKPSD (dBm / 3kHz)	Limit (dBm / 3kHz)	Result
Full BW	2404	-16.86	≤ 8.00	Pass
Full BW	2442	-16.12	≤ 8.00	Pass
Full BW	2478	-16.20	≤ 8.00	Pass
Half BW	2404	-13.16	≤ 8.00	Pass
Half BW	2442	-12.86	≤ 8.00	Pass
Half BW	2478	-12.79	≤ 8.00	Pass

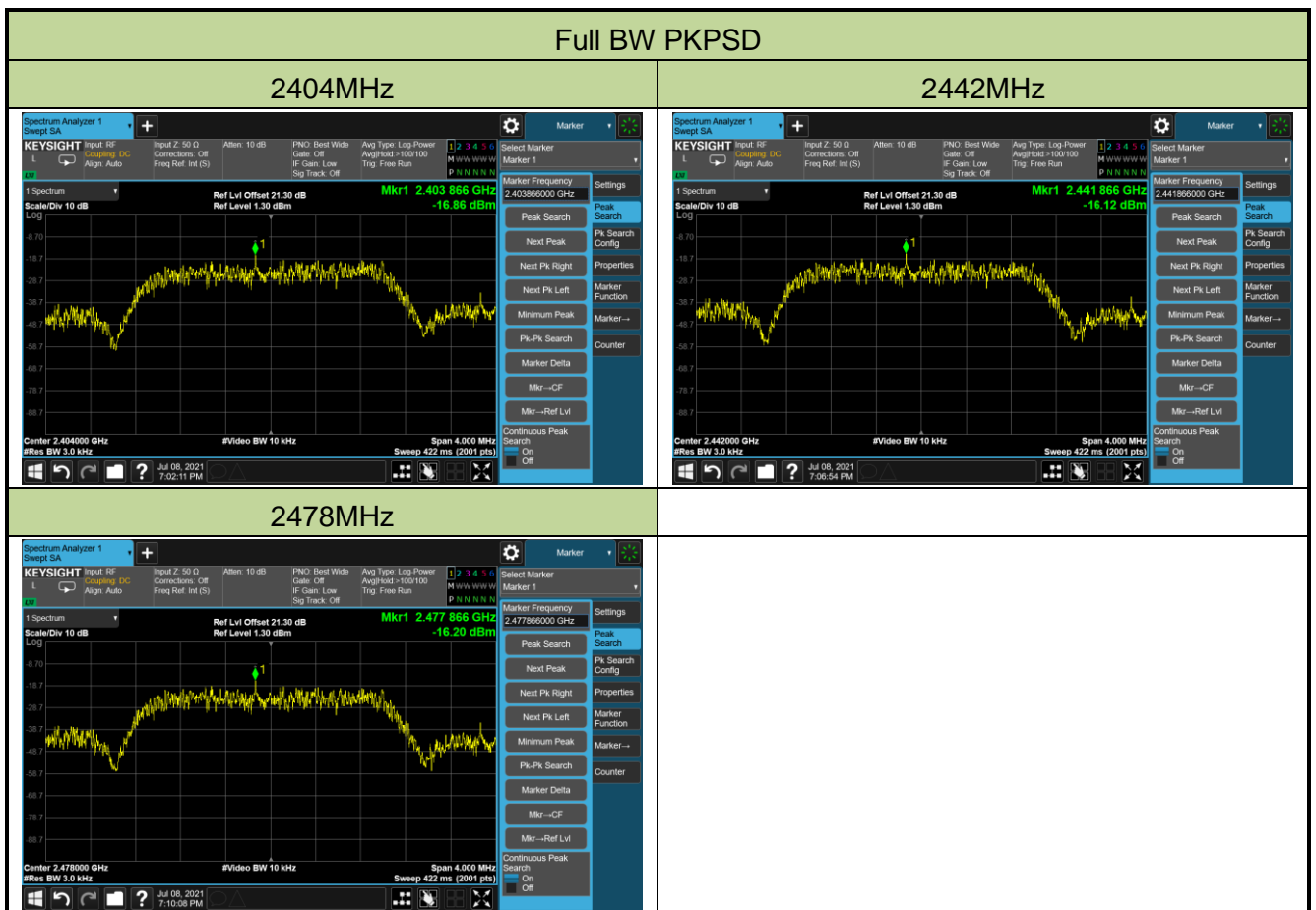

Half BW - PKPSD

2404MHz



2442MHz



2478MHz



6.5. Conducted Band Edge and Out-of-Band Emissions

6.5.1. Test Limit

The limit for out-of-band spurious emissions at the band edge is 20dB below the fundamental emission level, as determined from the in-band power measurement of the DTS channel performed in a 100 kHz bandwidth per the PSD procedure.

6.5.2. Test Procedure Used

ANSI C63.10-2013 - Section 11.11

6.5.3. Test Setting

Reference level measurement

1. Set instrument center frequency to DTS channel center frequency
2. Set the span to ≥ 1.5 times the DTS bandwidth
3. Set the RBW = 100 kHz
4. Set the VBW $\geq 3 \times$ RBW
5. Detector = peak
6. Sweep time = auto couple
7. Trace mode = max hold
8. Allow trace to fully stabilize

Emission level measurement

1. Set the center frequency and span to encompass frequency range to be measured
2. RBW = 100kHz
3. VBW = 300kHz
4. Detector = Peak
5. Trace mode = max hold
6. Sweep time = auto couple
7. The trace was allowed to stabilize

6.5.4. Test Setup

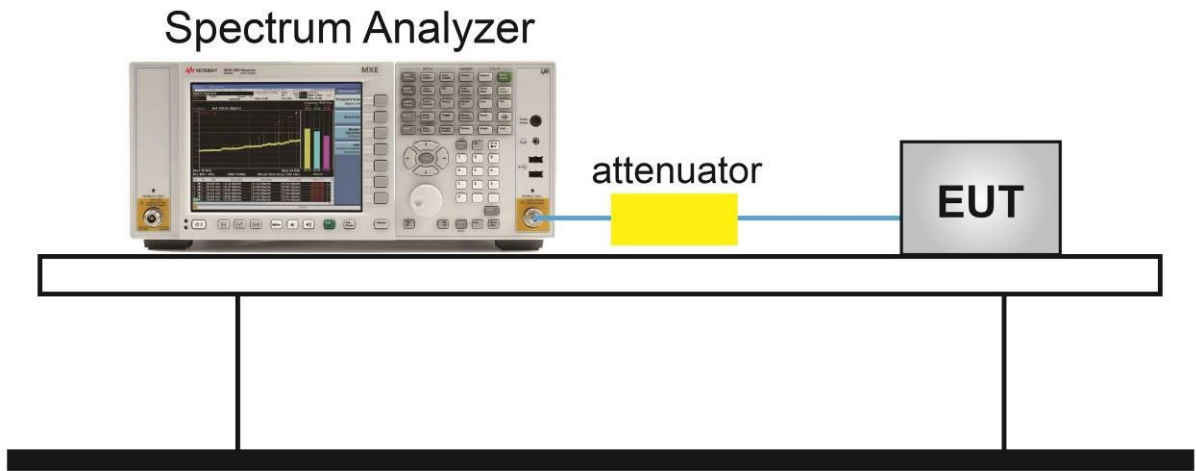

6.5.5. Test Result

Test Site	SIP-TR1	Test Engineer	Alisa Deng
Test Date	2021/07/08		

Test Mode	Frequency (MHz)	Limit	Result
Full BW	2404	20dBc	Pass
Full BW	2442	20dBc	Pass
Full BW	2478	20dBc	Pass
Half BW	2404	20dBc	Pass
Half BW	2442	20dBc	Pass
Half BW	2478	20dBc	Pass

Full BW Out-of-Band Emissions

2404MHz

100kHz PSD Reference Level



Low Band Edge



Spurious Emission

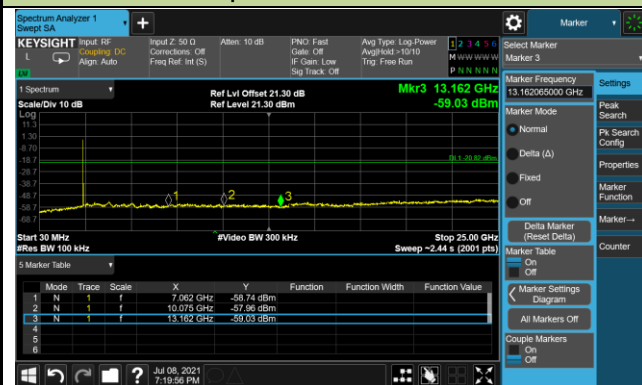

2442MHz

100kHz PSD Reference Level

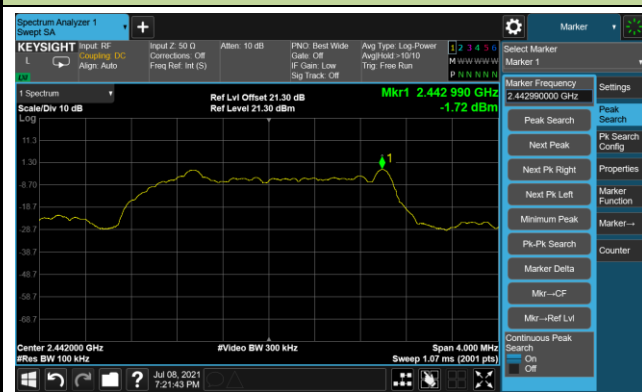

Spurious Emission

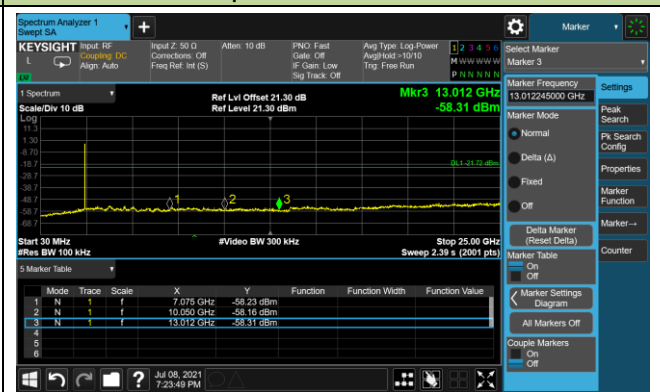

Full BW Out-of-Band Emissions

2478MHz

100kHz PSD Reference Level



High Band Edge



Spurious Emission

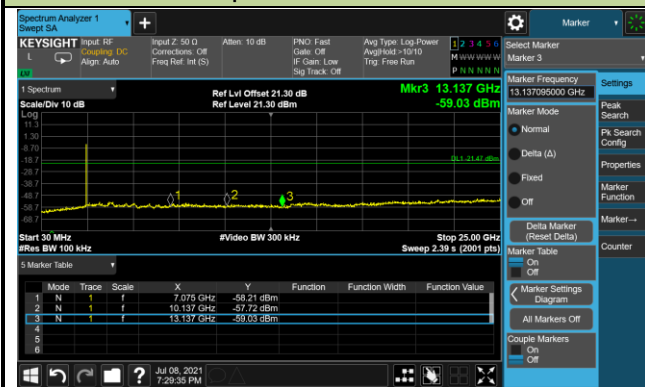

Half BW Out-of-Band Emissions

2404MHz

100kHz PSD Reference Level

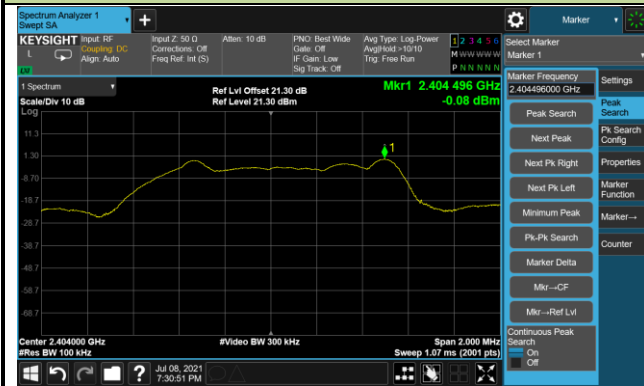

Low Band Edge



Spurious Emission

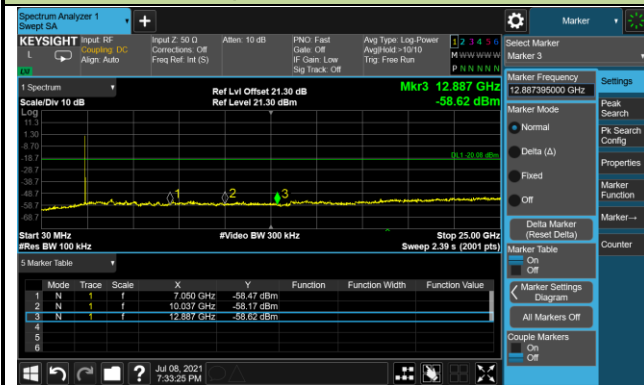

2442MHz

100kHz PSD Reference Level



Spurious Emission

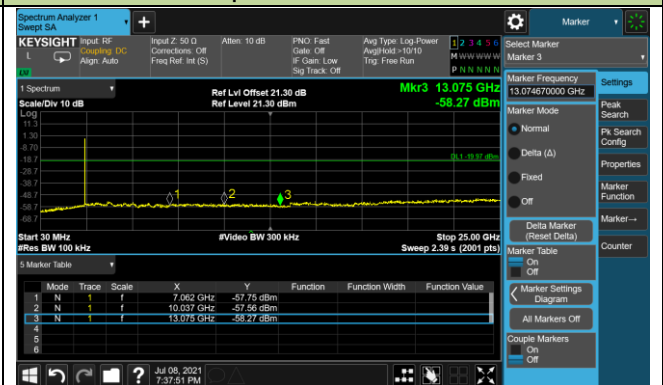

Half BW Out-of-Band Emissions

2478MHz

100kHz PSD Reference Level

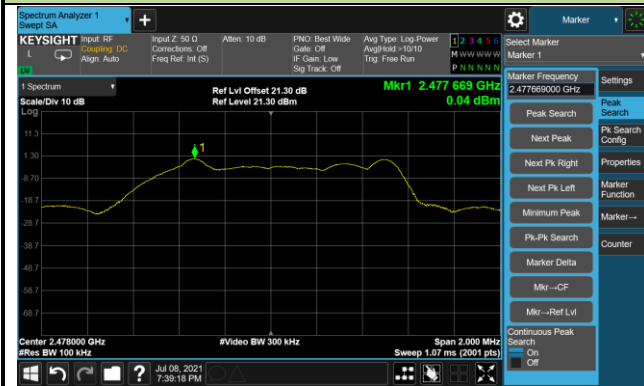

High Band Edge



Spurious Emission

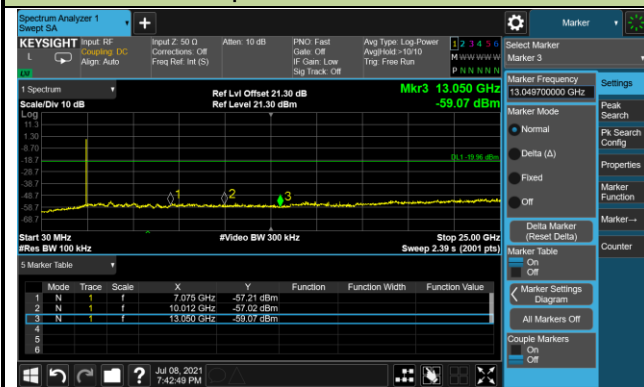

6.6. Radiated Spurious Emission Measurement

6.6.1. Test Limit

All out of band emissions appearing in a restricted band as specified in Section 15.205 of the Title 47 CFR must not exceed the limits shown in Table per Section 15.209.

FCC Part 15 Subpart C Paragraph 15.209		
Frequency [MHz]	Field Strength [uV/m]	Measured Distance [Meters]
0.009 - 0.490	2400/F (kHz)	300
0.490 - 1.705	24000/F (kHz)	30
1.705 - 30	30	30
30 - 88	100	3
88 - 216	150	3
216 - 960	200	3
Above 960	500	3

6.6.2. Test Procedure Used

ANSI C63.10-2013 - Section 6.3 & 6.4 & 6.5 & 6.6

6.6.3. Test Setting

Table 1 - RBW as a function of frequency

Frequency	RBW
9 ~ 150 kHz	200 ~ 300 Hz
0.15 ~ 30 MHz	9 ~ 10 kHz
30 ~ 1000 MHz	100 ~ 120 kHz
> 1000MHz	1MHz

Quasi-Peak Measurements below 1GHz

1. Analyzer center frequency was set to the frequency of the radiated spurious emission of interest
2. Span was set greater than 1MHz
3. RBW = as specified in Table 1
4. Detector = CISPR quasi-peak
5. Sweep time = auto couple
6. Trace was allowed to stabilize

Peak Measurements above 1GHz

1. Analyzer center frequency was set to the frequency of the radiated spurious emission of interest
2. RBW = 1MHz
3. VBW = 3MHz
4. Detector = peak
5. Sweep time = auto couple
6. Trace mode = max hold
7. Trace was allowed to stabilize

Average Measurements above 1GHz (Method VB)

1. Analyzer center frequency was set to the frequency of the radiated spurious emission of interest
2. RBW = 1MHz
3. VBW; If the EUT is configured to transmit with duty cycle $\geq 98\%$, set VBW = 10 Hz.
If the EUT duty cycle is $< 98\%$, set VBW $\geq 1/T$. T is the minimum transmission duration.
4. Detector = Peak
5. Sweep time = auto
6. Trace mode = max hold
7. Trace was allowed to stabilize

6.6.4. Test Setup

Below 1GHz Test Setup:

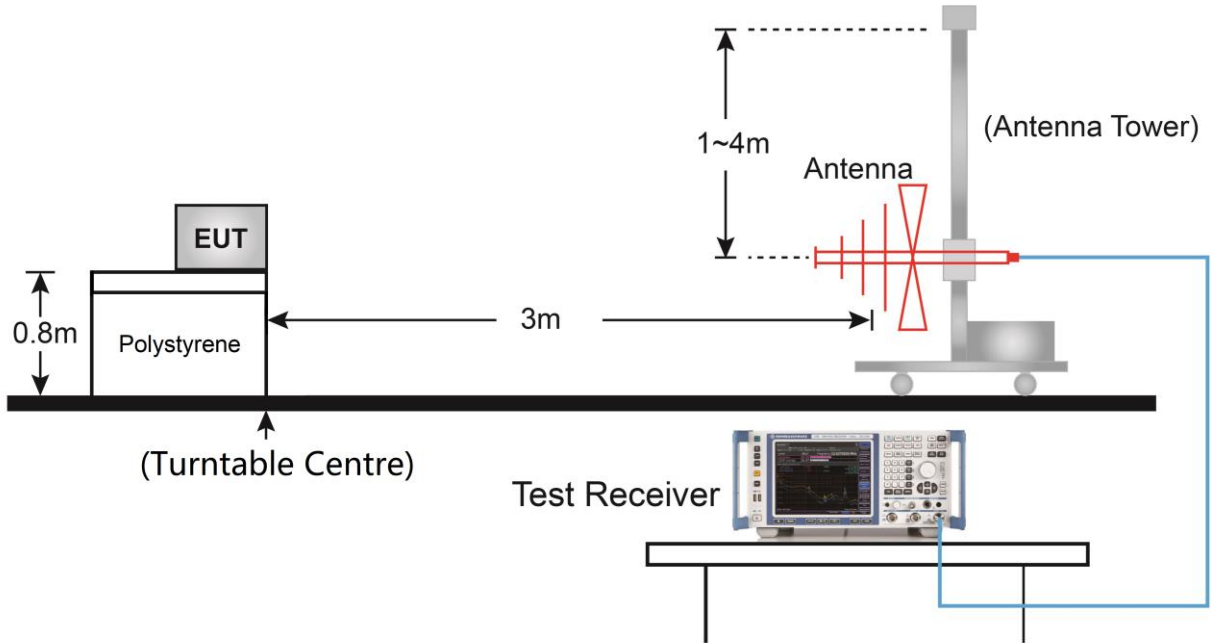

Above 1GHz Test Setup:

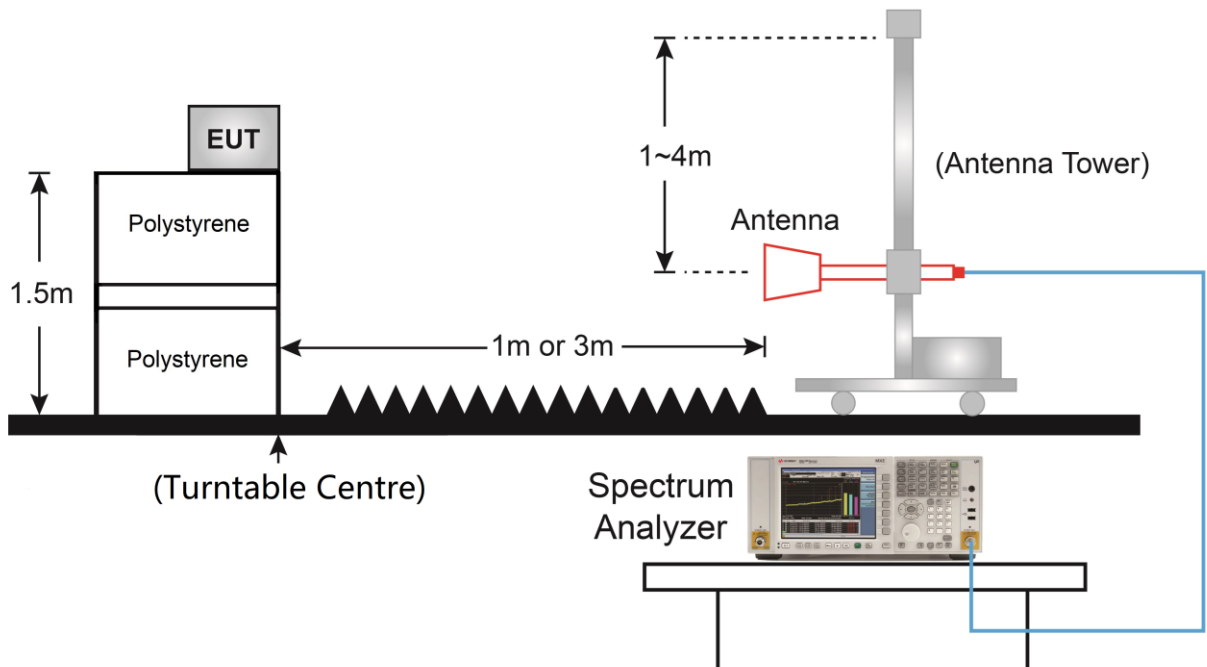

6.6.5. Test Result

Test Site	SIP-AC3	Test Engineer	Mero Zhou
Test Date	2021/07/14	Test Frequency	2404MHz
Test Mode	Full BW		
Remark	1. Average measurement was not performed if peak level lower than average limit. 2. Other frequency was 20dB below limit line within 1-18GHz, there is not show in the report.		

Mark	Frequency (MHz)	Reading Level (dB μ V)	Factor (dB)	Measure Level (dB μ V/m)	Limit (dB μ V/m)	Margin (dB)	Detector	Polarization
	8140.0	50.6	-4.4	46.2	74.0	-27.8	Peak	Horizontal
	11489.0	49.4	-2.6	46.8	74.0	-27.2	Peak	Horizontal
*	15730.5	47.5	3.8	51.3	74.0	-22.7	Peak	Horizontal
	8378.0	50.7	-4.0	46.7	74.0	-27.3	Peak	Vertical
	11727.0	49.6	-2.8	46.8	74.0	-27.2	Peak	Vertical
*	15747.5	46.7	4.3	51.0	74.0	-23.0	Peak	Vertical

Note 1: "*" means test frequency didn't fall into restricted band.

Note 2: Measure Level (dB μ V/m) = Reading Level (dB μ V) + Factor (dB)

Factor (dB) = Cable Loss (dB) + Antenna Factor (dB/m) - Pre_Amplifier Gain (dB)

Test Site	SIP-AC3	Test Engineer	Mero Zhou
Test Date	2021/07/14	Test Frequency	2442MHz
Test Mode	Full BW		
Remark	1. Average measurement was not performed if peak level lower than average limit. 2. Other frequency was 20dB below limit line within 1-18GHz, there is not show in the report.		

Mark	Frequency (MHz)	Reading Level (dBμV)	Factor (dB)	Measure Level (dBμV/m)	Limit (dBμV/m)	Margin (dB)	Detector	Polarization
	8335.5	50.5	-4.1	46.4	74.0	-27.6	Peak	Horizontal
	11897.0	50.4	-2.2	48.2	74.0	-25.8	Peak	Horizontal
*	15773.0	45.6	3.8	49.4	74.0	-24.6	Peak	Horizontal
	8182.5	51.1	-4.3	46.8	74.0	-27.2	Peak	Vertical
	11778.0	50.2	-2.6	47.6	74.0	-26.4	Peak	Vertical
*	15747.5	48.3	4.3	52.6	74.0	-21.4	Peak	Vertical

Note 1: "*" means test frequency didn't fall into restricted band.

Note 2: Measure Level (dBμV/m) = Reading Level (dBμV) + Factor (dB)

Factor (dB) = Cable Loss (dB) + Antenna Factor (dB/m) - Pre_Amplifier Gain (dB)

Test Site	SIP-AC3	Test Engineer	Mero Zhou
Test Date	2021/07/14	Test Frequency	2478MHz
Test Mode	Full BW		
Remark	1. Average measurement was not performed if peak level lower than average limit. 2. Other frequency was 20dB below limit line within 1-18GHz, there is not show in the report.		

Mark	Frequency (MHz)	Reading Level (dBμV)	Factor (dB)	Measure Level (dBμV/m)	Limit (dBμV/m)	Margin (dB)	Detector	Polarization
	8276.0	50.4	-4.1	46.3	74.0	-27.7	Peak	Horizontal
	12126.5	49.5	-2.2	47.3	74.0	-26.7	Peak	Horizontal
*	15756.0	46.3	4.4	50.7	74.0	-23.3	Peak	Horizontal
	8165.5	51.6	-4.3	47.3	74.0	-26.7	Peak	Vertical
	12084.0	51.1	-2.2	48.9	74.0	-25.1	Peak	Vertical
*	16062.0	46.8	5.2	52.0	74.0	-22.0	Peak	Vertical

Note 1: "*" means test frequency didn't fall into restricted band.

Note 2: Measure Level (dBμV/m) = Reading Level (dBμV) + Factor (dB)

Factor (dB) = Cable Loss (dB) + Antenna Factor (dB/m) - Pre_Amplifier Gain (dB)

Test Site	SIP-AC3	Test Engineer	Mero Zhou
Test Date	2021/07/14	Test Frequency	2404MHz
Test Mode	Half BW		
Remark	1. Average measurement was not performed if peak level lower than average limit. 2. Other frequency was 20dB below limit line within 1-18GHz, there is not show in the report.		

Mark	Frequency (MHz)	Reading Level (dBμV)	Factor (dB)	Measure Level (dBμV/m)	Limit (dBμV/m)	Margin (dB)	Detector	Polarization
	8276.0	50.8	-4.1	46.7	74.0	-27.3	Peak	Horizontal
	12092.5	50.4	-2.1	48.3	74.0	-25.7	Peak	Horizontal
*	16062.0	47.0	5.2	52.2	74.0	-21.8	Peak	Horizontal
	8276.0	50.6	-4.1	46.5	74.0	-27.5	Peak	Vertical
	12296.5	50.1	-1.9	48.2	74.0	-25.8	Peak	Vertical
*	16104.5	48.4	4.0	52.4	74.0	-21.6	Peak	Vertical

Note 1: "*" means test frequency didn't fall into restricted band.

Note 2: Measure Level (dBμV/m) = Reading Level (dBμV) + Factor (dB)

Factor (dB) = Cable Loss (dB) + Antenna Factor (dB/m) - Pre_Amplifier Gain (dB)

Test Site	SIP-AC3	Test Engineer	Mero Zhou
Test Date	2021/07/14	Test Frequency	2442MHz
Test Mode	Half BW		
Remark	1. Average measurement was not performed if peak level lower than average limit. 2. Other frequency was 20dB below limit line within 1-18GHz, there is not show in the report.		

Mark	Frequency (MHz)	Reading Level (dBμV)	Factor (dB)	Measure Level (dBμV/m)	Limit (dBμV/m)	Margin (dB)	Detector	Polarization
	8284.5	50.2	-4.1	46.1	74.0	-27.9	Peak	Horizontal
	12118.0	51.4	-2.1	49.3	74.0	-24.7	Peak	Horizontal
*	16070.5	47.5	4.9	52.4	74.0	-21.6	Peak	Horizontal
	8284.5	50.2	-4.1	46.1	74.0	-27.9	Peak	Vertical
	11905.5	50.3	-2.3	48.0	74.0	-26.0	Peak	Vertical
*	16053.5	46.6	5.0	51.6	74.0	-22.4	Peak	Vertical

Note 1: "*" means test frequency didn't fall into restricted band.

Note 2: Measure Level (dBμV/m) = Reading Level (dBμV) + Factor (dB)

Factor (dB) = Cable Loss (dB) + Antenna Factor (dB/m) - Pre_Amplifier Gain (dB)

Test Site	SIP-AC3	Test Engineer	Mero Zhou
Test Date	2021/07/14	Test Frequency	2478MHz
Test Mode	Half BW		
Remark	1. Average measurement was not performed if peak level lower than average limit. 2. Other frequency was 20dB below limit line within 1-18GHz, there is not show in the report.		

Mark	Frequency (MHz)	Reading Level (dB μ V)	Factor (dB)	Measure Level (dB μ V/m)	Limit (dB μ V/m)	Margin (dB)	Detector	Polarization
	8199.5	51.0	-4.4	46.6	74.0	-27.4	Peak	Horizontal
	11735.5	50.8	-2.9	47.9	74.0	-26.1	Peak	Horizontal
*	16155.5	46.9	5.1	52.0	74.0	-22.0	Peak	Horizontal
	8208.0	50.5	-4.4	46.1	74.0	-27.9	Peak	Vertical
	11608.0	50.5	-2.9	47.6	74.0	-26.4	Peak	Vertical
*	15824.0	47.0	4.5	51.5	74.0	-22.5	Peak	Vertical

Note 1: "*" means test frequency didn't fall into restricted band.

Note 2: Measure Level (dB μ V/m) = Reading Level (dB μ V) + Factor (dB)

Factor (dB) = Cable Loss (dB) + Antenna Factor (dB/m) - Pre_Amplifier Gain (dB)

The Result of Radiated Emission below 1GHz:

Site: SIP-AC2	Time: 2021/07/15
Limit: FCC_Part15.209_RSE(3m)	Engineer: Edward Zhang
Probe: SIP-AC2_VULB 9168 _30-1000MHz	Polarity: Horizontal
EUT: Wireless Handheld Transmitter	Power: By Battery
Test Mode: Transmit by Half mode bandwidth at channel 2404MHz	

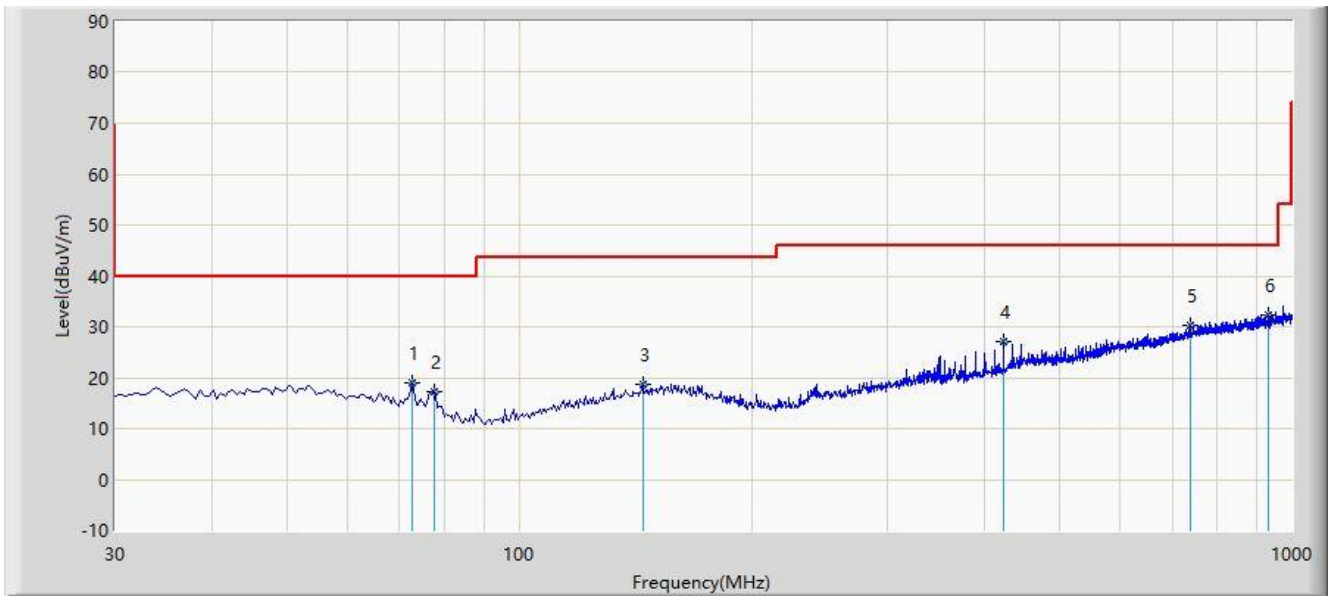

No	Flag	Mark	Frequency (MHz)	Measure Level (dBuV/m)	Reading Level (dBuV)	Margin (dB)	Limit (dBuV/m)	Factor (dB)	Type
1			72.680	19.047	3.198	-20.953	40.000	15.849	QP
2			77.530	17.356	2.516	-22.644	40.000	14.840	QP
3			144.460	18.736	0.298	-24.764	43.500	18.438	QP
4			423.335	27.101	5.057	-18.899	46.000	22.044	QP
5			739.555	30.365	2.087	-15.635	46.000	28.278	QP
6		*	933.070	32.318	1.956	-13.682	46.000	30.362	QP

Note 1: Measure Level (dB μ V/m) = Reading Level (dB μ V) + Factor (dB)

Factor (dB) = Cable Loss (dB) + Antenna Factor (dB/m)

Note 2: The amplitude of radiated emissions (frequency range from 9kHz to 30MHz and 18GHz to 25GHz) is that proximity to ambient noise, which also are attenuated more than 20 dB below the permissible value.

Therefore, the data is not presented in the report.

Site: SIP-AC2	Time: 2021/07/15
Limit: FCC_Part15.209_RSE(3m)	Engineer: Edward Zhang
Probe: SIP-AC2_VULB 9168 _30-1000MHz	Polarity: Vertical
EUT: Wireless Handheld Transmitter	Power: By Battery
Test Mode: Transmit by Half mode bandwidth at channel 2404MHz	

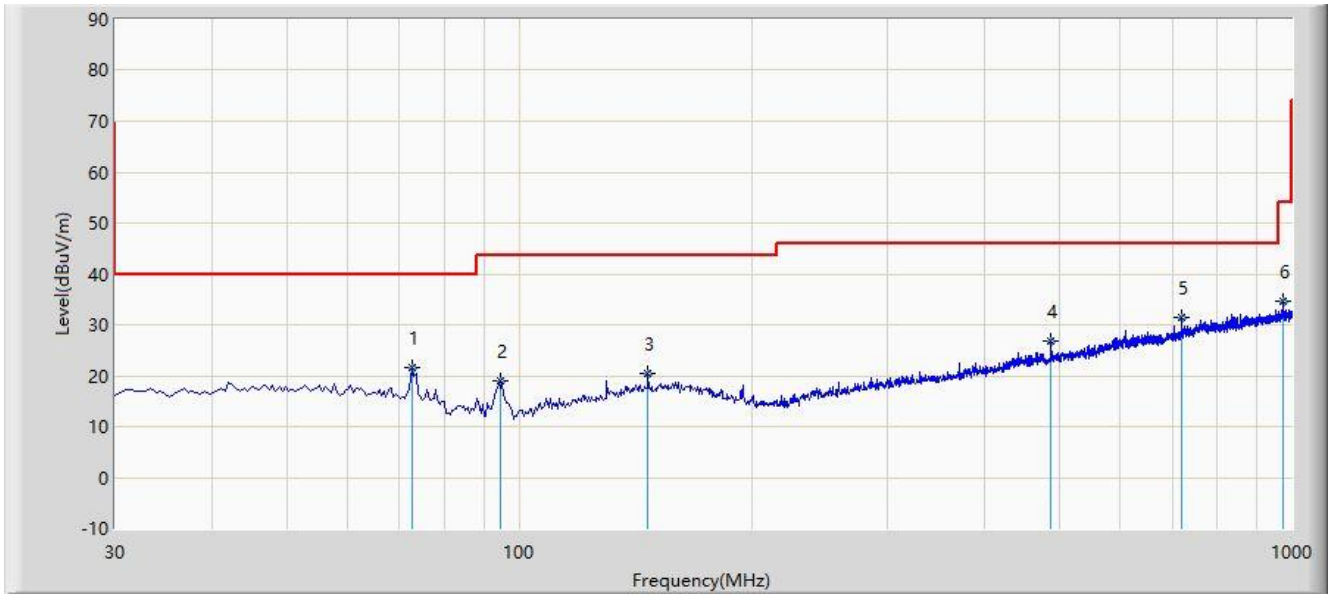

No	Flag	Mark	Frequency (MHz)	Measure Level (dBuV/m)	Reading Level (dBuV)	Margin (dB)	Limit (dBuV/m)	Factor (dB)	Type
1			72.680	21.468	5.619	-18.532	40.000	15.849	QP
2			94.505	19.095	6.179	-24.405	43.500	12.917	QP
3			146.885	20.475	1.962	-23.025	43.500	18.514	QP
4			487.355	26.784	3.365	-19.216	46.000	23.418	QP
5		*	720.155	31.398	3.761	-14.602	46.000	27.637	QP
6			975.265	34.644	3.661	-19.356	54.000	30.983	QP

Note 1: Measure Level (dB μ V/m) = Reading Level (dB μ V) + Factor (dB)

Factor (dB) = Cable Loss (dB) + Antenna Factor (dB/m)

Note 2: The amplitude of radiated emissions (frequency range from 9kHz to 30MHz and 18GHz to 25GHz) is that proximity to ambient noise, which also are attenuated more than 20 dB below the permissible value.

Therefore, the data is not presented in the report.

6.7. Radiated Restricted Band Edge Measurement

6.7.1. Test Limit

For 15.205 requirement:

Radiated emissions which fall in the restricted bands, as defined in Section 15.205(a) of FCC part 15, must also comply with the radiated emission limits specified in Section 15.209(a).

Frequency (MHz)	Frequency (MHz)	Frequency (MHz)	Frequency (GHz)
0.090 - 0.110	16.42 - 16.423	399.9 - 410	4.5 - 5.15
¹ 0.495 - 0.505	16.69475 - 16.69525	608 - 614	5.35 - 5.46
2.1735 - 2.1905	16.80425 - 16.80475	960 - 1240	7.25 - 7.75
4.125 - 4.128	25.5 - 25.67	1300 - 1427	8.025 - 8.5
4.17725 - 4.17775	37.5 - 38.25	1435 - 1626.5	9.0 - 9.2
4.20725 - 4.20775	73 - 74.6	1645.5 - 1646.5	9.3 - 9.5
6.215 - 6.218	74.8 - 75.2	1660 - 1710	10.6 - 12.7
6.26775 - 6.26825	108 - 121.94	1718.8 - 1722.2	13.25 - 13.4
6.31175 - 6.31225	123 - 138	2200 - 2300	14.47 - 14.5
8.291 - 8.294	149.9 - 150.05	2310 - 2390	15.35 - 16.2
8.362 - 8.366	156.52475 - 156.52525	2483.5 - 2500	17.7 - 21.4
8.37625 - 8.38675	156.7 - 156.9	2690 - 2900	22.01 - 23.12
8.41425 - 8.41475	162.0125 - 167.17	3260 - 3267	23.6 - 24.0
12.29 - 12.293	167.72 - 173.2	3332 - 3339	31.2 - 31.8
12.51975 - 12.52025	240 - 285	3345.8 - 3358	36.43 - 36.5
12.57675 - 12.57725	322 - 335.4	3600 - 4400	(²)
13.36 - 13.41	--	--	--

All out of band emissions appearing in a restricted band as specified in Section 15.205 of the Title 47CFR must not exceed the limits shown in Table per Section 15.209.

FCC Part 15 Subpart C Paragraph 15.209		
Frequency [MHz]	Field Strength [uV/m]	Measured Distance [Meters]
0.009 - 0.490	2400/F (kHz)	300
0.490 - 1.705	24000/F (kHz)	30
1.705 - 30	30	30
30 - 88	100	3
88 - 216	150	3
216 - 960	200	3
Above 960	500	3

6.7.2. Test Procedure Used

ANSI C63.10-2013 Section 6.3

ANSI C63.10-2013 Section 6.6

ANSI C63.10-2013 Section 11.13

6.7.3. Test Setting

Peak Field Strength Measurements

1. Analyzer center frequency was set to the frequency of the radiated spurious emission of interest
2. RBW = 1MHz
3. VBW = 3MHz
4. Detector = peak
5. Sweep time = auto couple
6. Trace mode = max hold
7. Trace was allowed to stabilize

Average Field Strength Measurements

1. Analyzer center frequency was set to the frequency of the radiated spurious emission of interest
2. RBW = 1MHz
3. VBW $\geq 1/T$
4. As an alternative, the instrument may be set to linear detector mode. Ensure that video filtering is applied in linear voltage domain (rather than in a log or dB domain). Some instruments require linear display mode in order to accomplish this. Others have a setting for Average-VBW Type, which can be set to "Voltage" regardless of the display mode
5. Detector = Peak
6. Sweep time = auto
7. Trace mode = max hold
8. Allow max hold to run for at least 50 times (1/duty cycle) traces

6.7.4. Test Setup

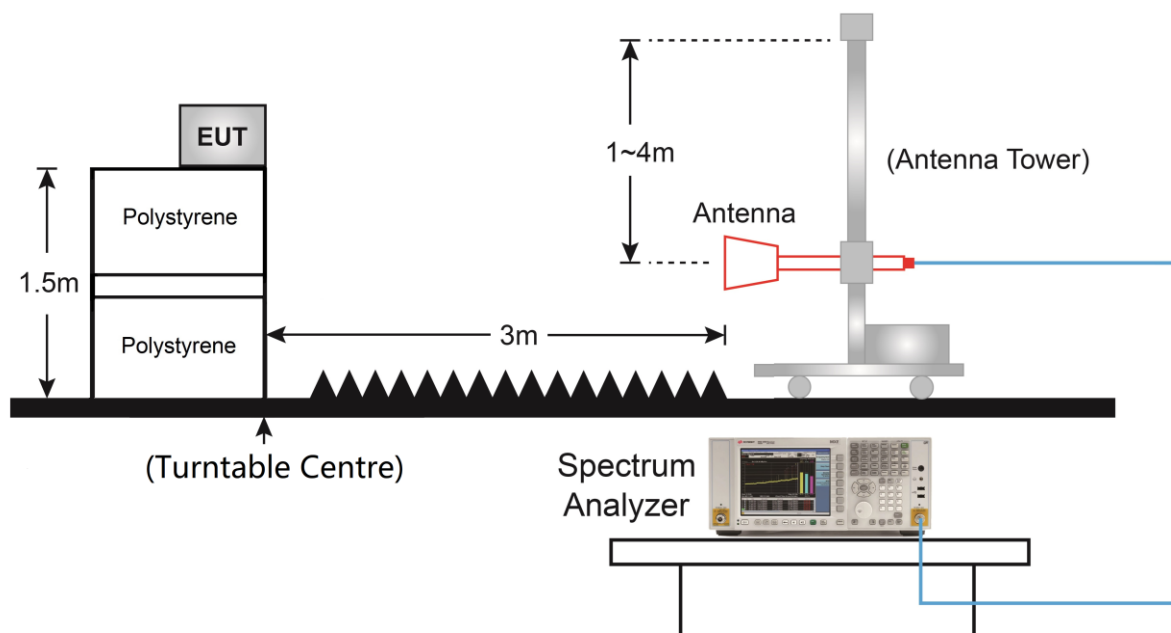

6.7.5. Test Result

Site: SIP-AC3	Time: 2021/07/14
Limit: FCC_Part15_15.209 RE(3m)	Engineer: Stephen Dong
Probe: SIP-AC3_HF907_102861_1-18GHz	Polarity: Horizontal
EUT: Wireless Handheld Transmitter	Power: By Battery
Note: Transmit by Full Bandwidth at Channel 2404MHz	

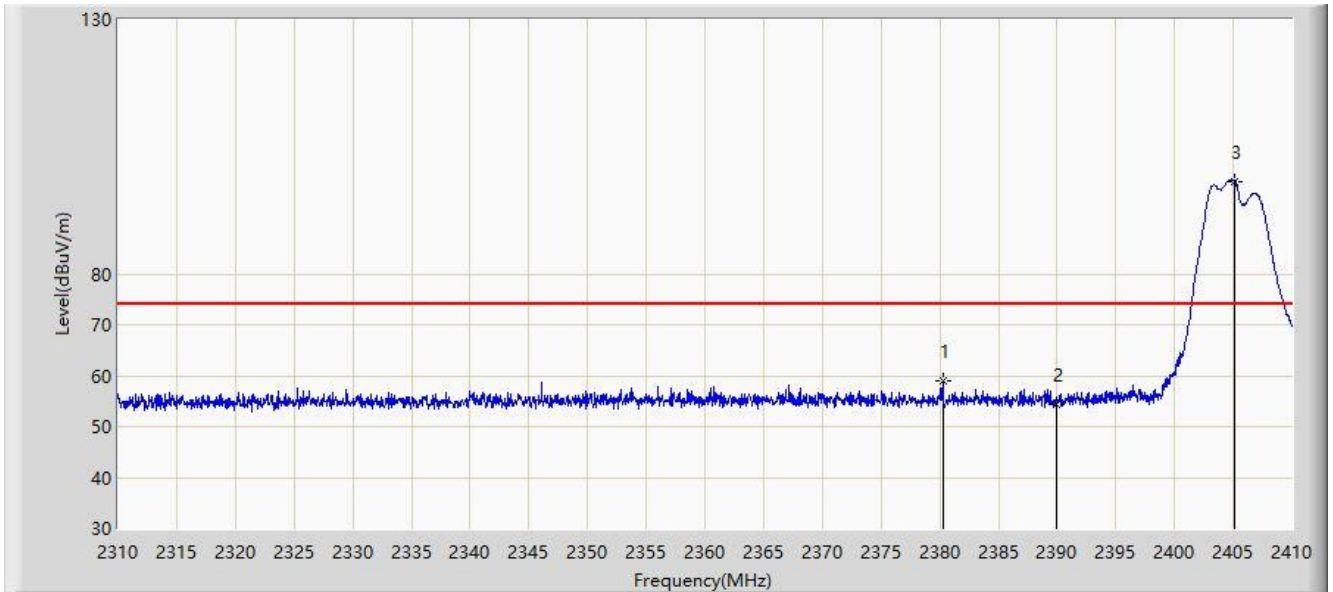

No	Flag	Mark	Frequency (MHz)	Measure Level (dBuV/m)	Reading Level (dBuV)	Margin (dB)	Limit (dBuV/m)	Factor (dB)	Type
1			2380.250	58.915	26.703	-15.085	74.000	32.211	PK
2			2390.000	54.448	22.183	-19.552	74.000	32.265	PK
3		*	2405.150	98.184	65.841	N/A	N/A	32.344	PK

Note: Measure Level (dB μ V/m) = Reading Level (dB μ V) + Factor (dB)

Factor (dB) = Cable Loss (dB) + Antenna Factor (dB/m).

Site: SIP-AC3	Time: 2021/07/14
Limit: FCC_Part15_15.209 RE(3m)	Engineer: Stephen Dong
Probe: SIP-AC3_HF907_102861_1-18GHz	Polarity: Horizontal
EUT: Wireless Handheld Transmitter	Power: By Battery
Note: Transmit by Full Bandwidth at Channel 2404MHz	

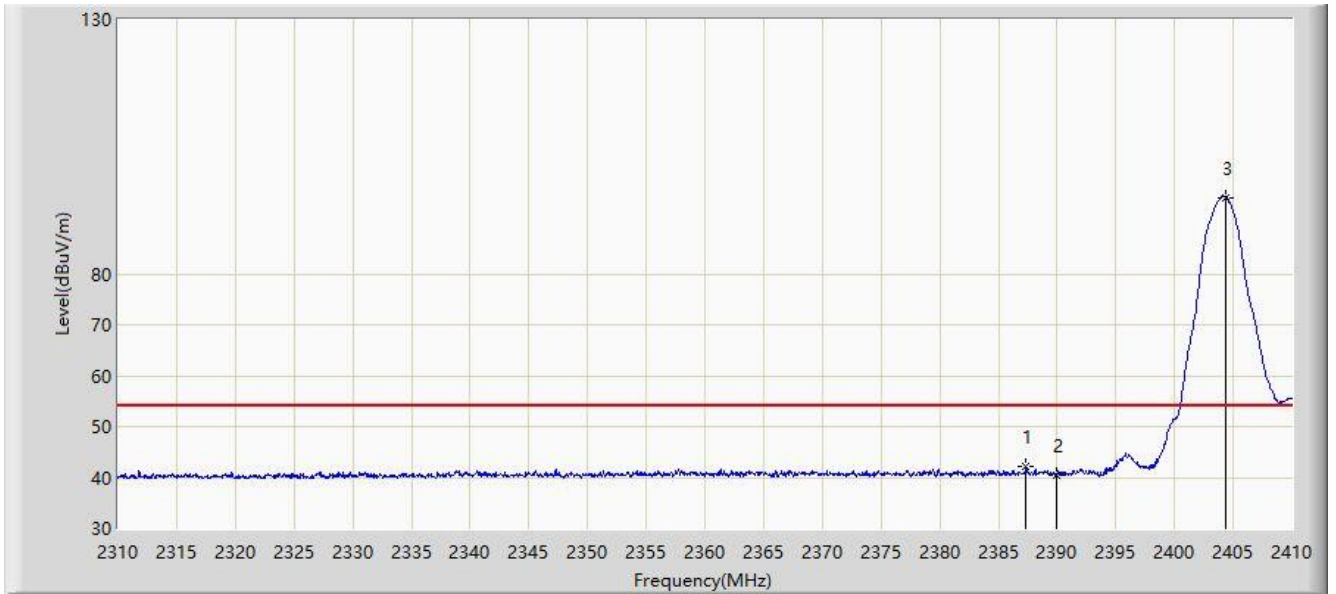

No	Flag	Mark	Frequency (MHz)	Measure Level (dBuV/m)	Reading Level (dBuV)	Margin (dB)	Limit (dBuV/m)	Factor (dB)	Type
1			2387.350	42.101	9.850	-11.899	54.000	32.251	AV
2			2390.000	40.497	8.232	-13.503	54.000	32.265	AV
3		*	2404.350	95.068	62.729	N/A	N/A	32.339	AV

Note: Measure Level (dB μ V/m) = Reading Level (dB μ V) + Factor (dB)

Factor (dB) = Cable Loss (dB) + Antenna Factor (dB/m).

Site: SIP-AC3	Time: 2021/07/14
Limit: FCC_Part15_15.209 RE(3m)	Engineer: Stephen Dong
Probe: SIP-AC3_HF907_102861_1-18GHz	Polarity: Vertical
EUT: Wireless Handheld Transmitter	Power: By Battery
Note: Transmit by Full Bandwidth at Channel 2404MHz	

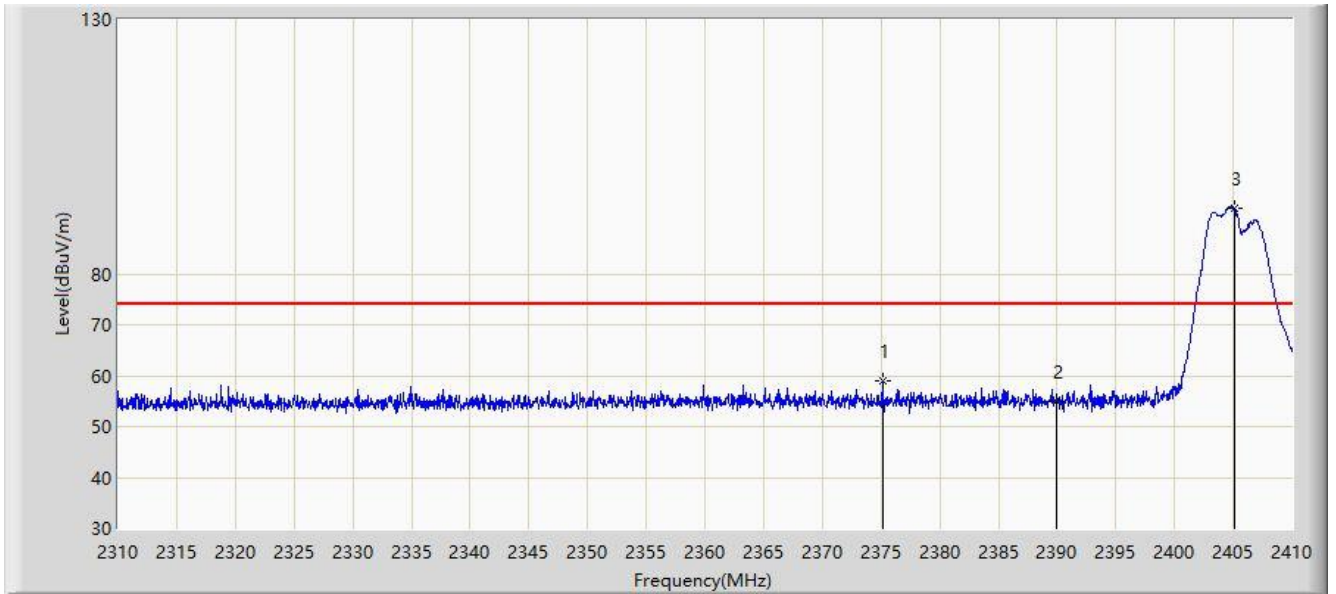

No	Flag	Mark	Frequency (MHz)	Measure Level (dBuV/m)	Reading Level (dBuV)	Margin (dB)	Limit (dBuV/m)	Factor (dB)	Type
1			2375.150	58.871	26.680	-15.129	74.000	32.191	PK
2			2390.000	54.854	22.589	-19.146	74.000	32.265	PK
3		*	2405.150	92.960	60.617	N/A	N/A	32.344	PK

Note: Measure Level (dB μ V/m) = Reading Level (dB μ V) + Factor (dB)

Factor (dB) = Cable Loss (dB) + Antenna Factor (dB/m).

Site: SIP-AC3	Time: 2021/07/14
Limit: FCC_Part15_15.209 RE(3m)	Engineer: Stephen Dong
Probe: SIP-AC3_HF907_102861_1-18GHz	Polarity: Vertical
EUT: Wireless Handheld Transmitter	Power: By Battery
Note: Transmit by Full Bandwidth at Channel 2404MHz	

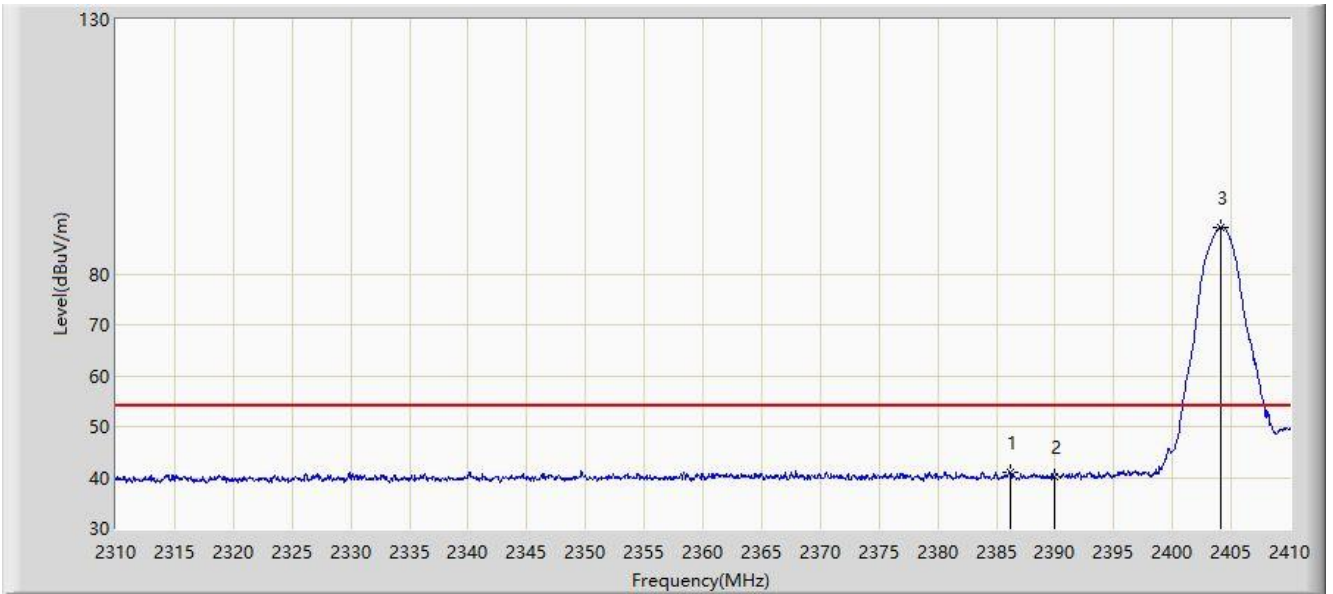

No	Flag	Mark	Frequency (MHz)	Measure Level (dBuV/m)	Reading Level (dBuV)	Margin (dB)	Limit (dBuV/m)	Factor (dB)	Type
1			2386.150	41.113	8.869	-12.887	54.000	32.244	AV
2			2390.000	40.265	8.000	-13.735	54.000	32.265	AV
3		*	2404.050	89.176	56.838	N/A	N/A	32.338	AV

Note: Measure Level (dBμV/m) = Reading Level (dBμV) + Factor (dB)

Factor (dB) = Cable Loss (dB) + Antenna Factor (dB/m).

Site: SIP-AC3	Time: 2021/07/14
Limit: FCC_Part15_15.209 RE(3m)	Engineer: Stephen Dong
Probe: SIP-AC3_HF907_102861_1-18GHz	Polarity: Horizontal
EUT: Wireless Handheld Transmitter	Power: By Battery
Note: Transmit by Full Bandwidth at Channel 2478MHz	

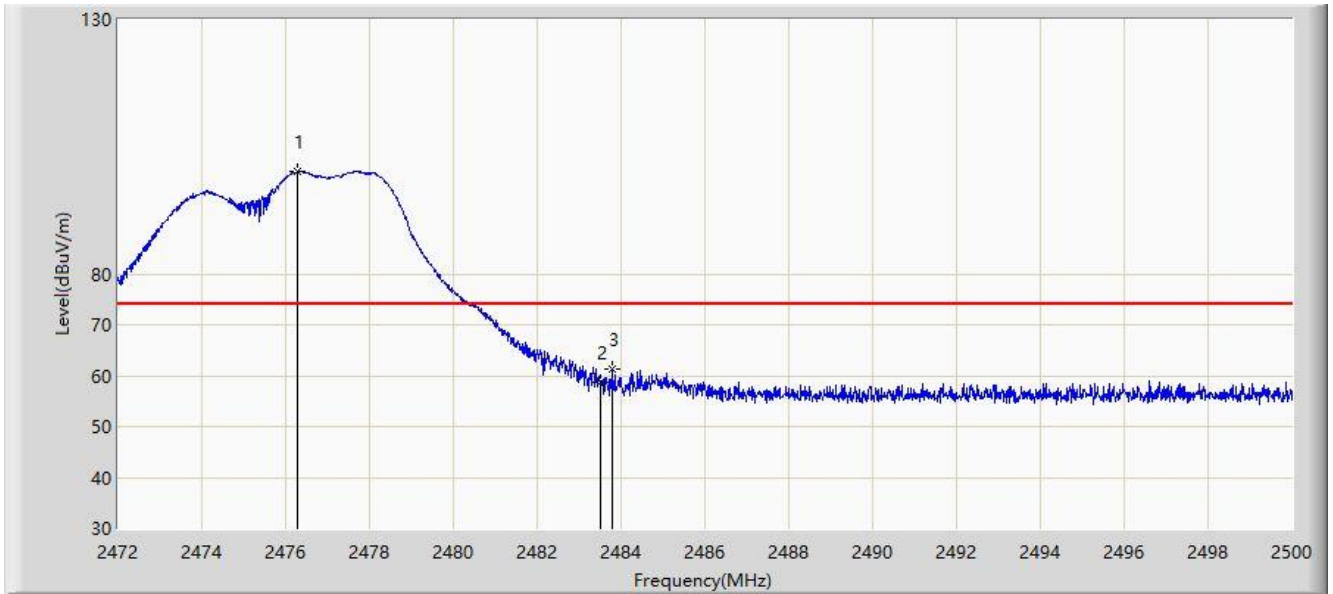

No	Flag	Mark	Frequency (MHz)	Measure Level (dBuV/m)	Reading Level (dBuV)	Margin (dB)	Limit (dBuV/m)	Factor (dB)	Type
1		*	2476.298	100.172	67.444	N/A	N/A	32.728	PK
2			2483.500	58.653	25.881	-15.347	74.000	32.772	PK
3			2483.788	61.376	28.603	-12.624	74.000	32.774	PK

Note: Measure Level (dB μ V/m) = Reading Level (dB μ V) + Factor (dB)

Factor (dB) = Cable Loss (dB) + Antenna Factor (dB/m).

Site: SIP-AC3	Time: 2021/07/14
Limit: FCC_Part15_15.209 RE(3m)	Engineer: Stephen Dong
Probe: SIP-AC3_HF907_102861_1-18GHz	Polarity: Horizontal
EUT: Wireless Handheld Transmitter	Power: By Battery
Note: Transmit by Full Bandwidth at Channel 2478MHz	

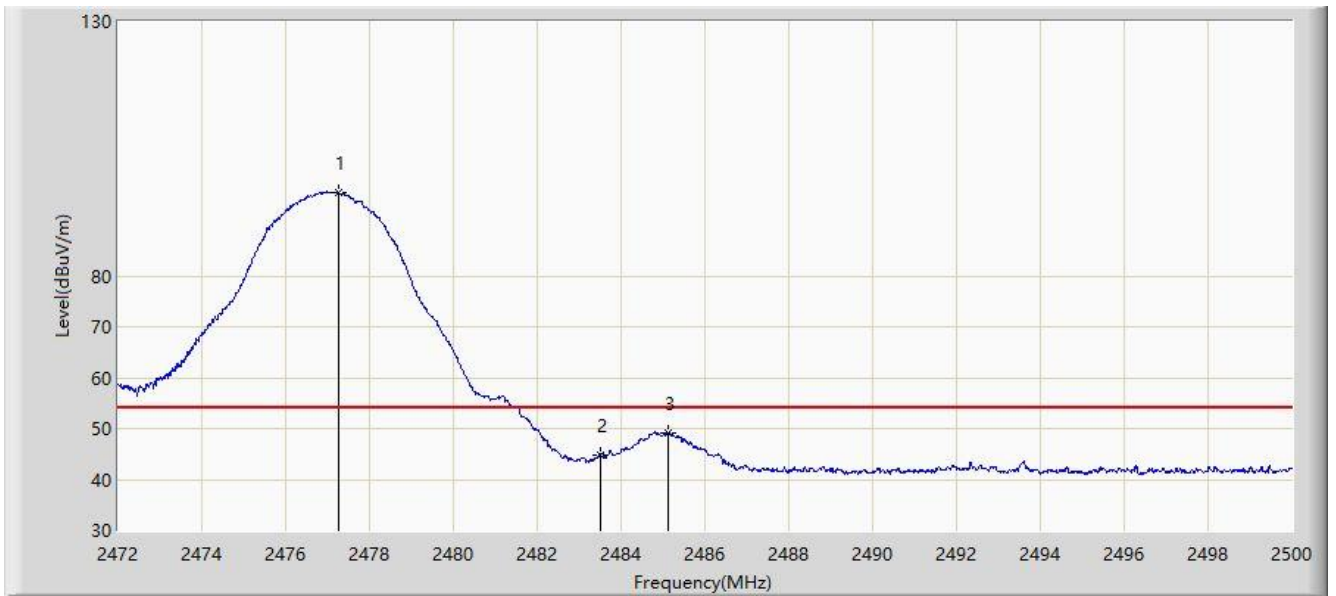

No	Flag	Mark	Frequency (MHz)	Measure Level (dBuV/m)	Reading Level (dBuV)	Margin (dB)	Limit (dBuV/m)	Factor (dB)	Type
1		*	2477.250	96.349	63.615	N/A	N/A	32.734	AV
2			2483.500	44.912	12.140	-9.088	54.000	32.772	AV
3			2485.132	49.134	16.353	-4.866	54.000	32.781	AV

Note: Measure Level (dBuV/m) = Reading Level (dBuV) + Factor (dB)

Factor (dB) = Cable Loss (dB) + Antenna Factor (dB/m).

Site: SIP-AC3	Time: 2021/07/14
Limit: FCC_Part15_15.209 RE(3m)	Engineer: Stephen Dong
Probe: SIP-AC3_HF907_102861_1-18GHz	Polarity: Vertical
EUT: Wireless Handheld Transmitter	Power: By Battery
Note: Transmit by Full Bandwidth at Channel 2478MHz	

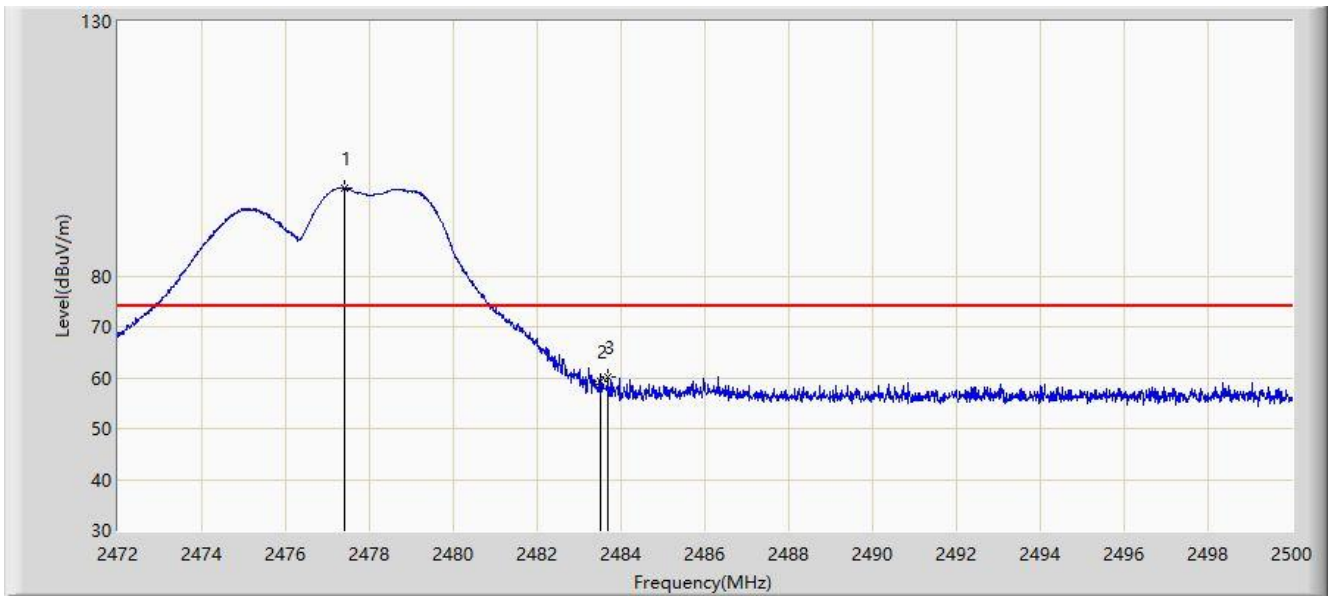

No	Flag	Mark	Frequency (MHz)	Measure Level (dBuV/m)	Reading Level (dBuV)	Margin (dB)	Limit (dBuV/m)	Factor (dB)	Type
1		*	2477.390	97.271	64.536	N/A	N/A	32.735	PK
2			2483.500	59.289	26.517	-14.711	74.000	32.772	PK
3			2483.690	60.057	27.284	-13.943	74.000	32.773	PK

Note: Measure Level (dB μ V/m) = Reading Level (dB μ V) + Factor (dB)

Factor (dB) = Cable Loss (dB) + Antenna Factor (dB/m).

Site: SIP-AC3	Time: 2021/07/14
Limit: FCC_Part15_15.209 RE(3m)	Engineer: Stephen Dong
Probe: SIP-AC3_HF907_102861_1-18GHz	Polarity: Vertical
EUT: Wireless Handheld Transmitter	Power: By Battery
Note: Transmit by Full Bandwidth at Channel 2478MHz	

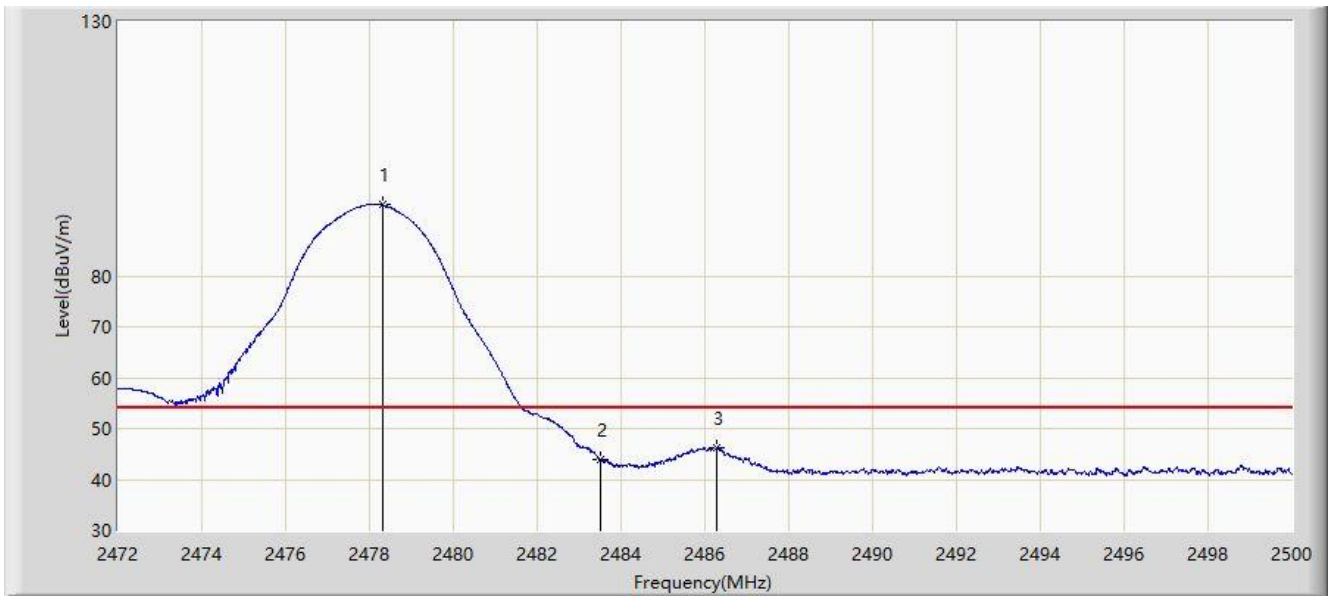

No	Flag	Mark	Frequency (MHz)	Measure Level (dBuV/m)	Reading Level (dBuV)	Margin (dB)	Limit (dBuV/m)	Factor (dB)	Type
1		*	2478.300	93.921	61.180	N/A	N/A	32.741	AV
2			2483.500	43.877	11.105	-10.123	54.000	32.772	AV
3			2486.294	46.325	13.537	-7.675	54.000	32.788	AV

Note: Measure Level (dBuV/m) = Reading Level (dBuV) + Factor (dB)

Factor (dB) = Cable Loss (dB) + Antenna Factor (dB/m).

Site: SIP-AC3	Time: 2021/07/14
Limit: FCC_Part15_15.209 RE(3m)	Engineer: Stephen Dong
Probe: SIP-AC3_HF907_102861_1-18GHz	Polarity: Horizontal
EUT: Wireless Handheld Transmitter	Power: By Battery
Note: Transmit by Half Bandwidth at Channel 2404MHz	

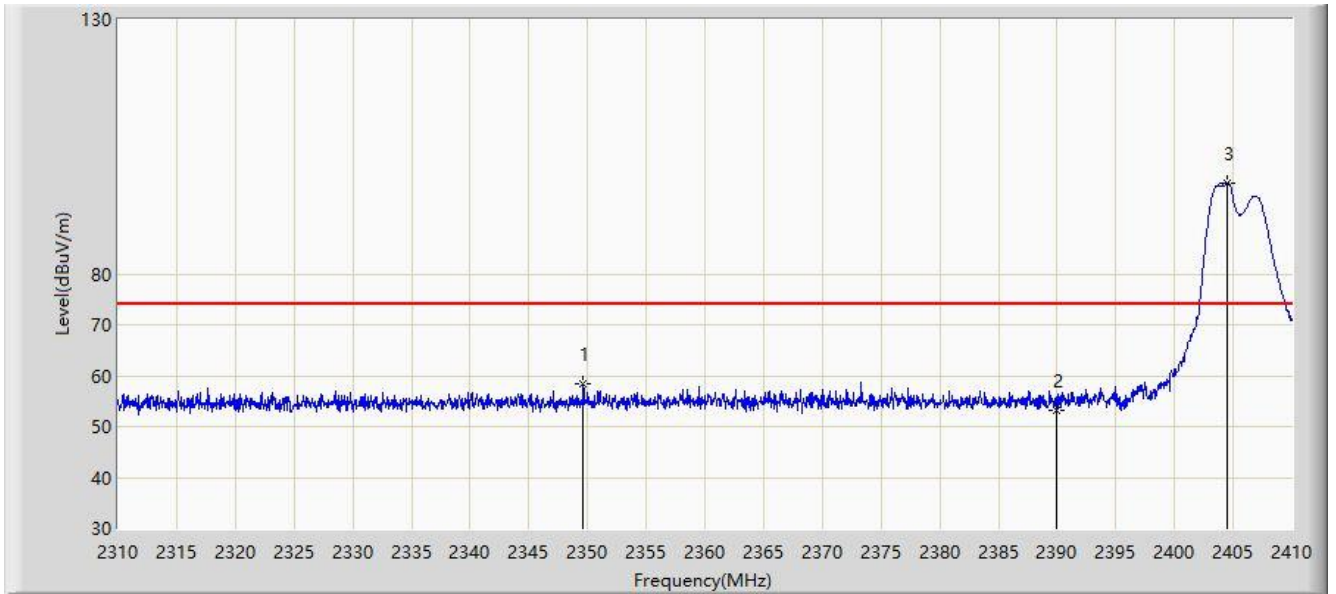

No	Flag	Mark	Frequency (MHz)	Measure Level (dBuV/m)	Reading Level (dBuV)	Margin (dB)	Limit (dBuV/m)	Factor (dB)	Type
1			2349.650	58.347	26.244	-15.653	74.000	32.103	PK
2			2390.000	53.210	20.945	-20.790	74.000	32.265	PK
3		*	2404.500	97.916	65.576	N/A	N/A	32.341	PK

Note: Measure Level (dB μ V/m) = Reading Level (dB μ V) + Factor (dB)

Factor (dB) = Cable Loss (dB) + Antenna Factor (dB/m).

Site: SIP-AC3	Time: 2021/07/14
Limit: FCC_Part15_15.209 RE(3m)	Engineer: Stephen Dong
Probe: SIP-AC3_HF907_102861_1-18GHz	Polarity: Horizontal
EUT: Wireless Handheld Transmitter	Power: By Battery
Note: Transmit by Half Bandwidth at Channel 2404MHz	

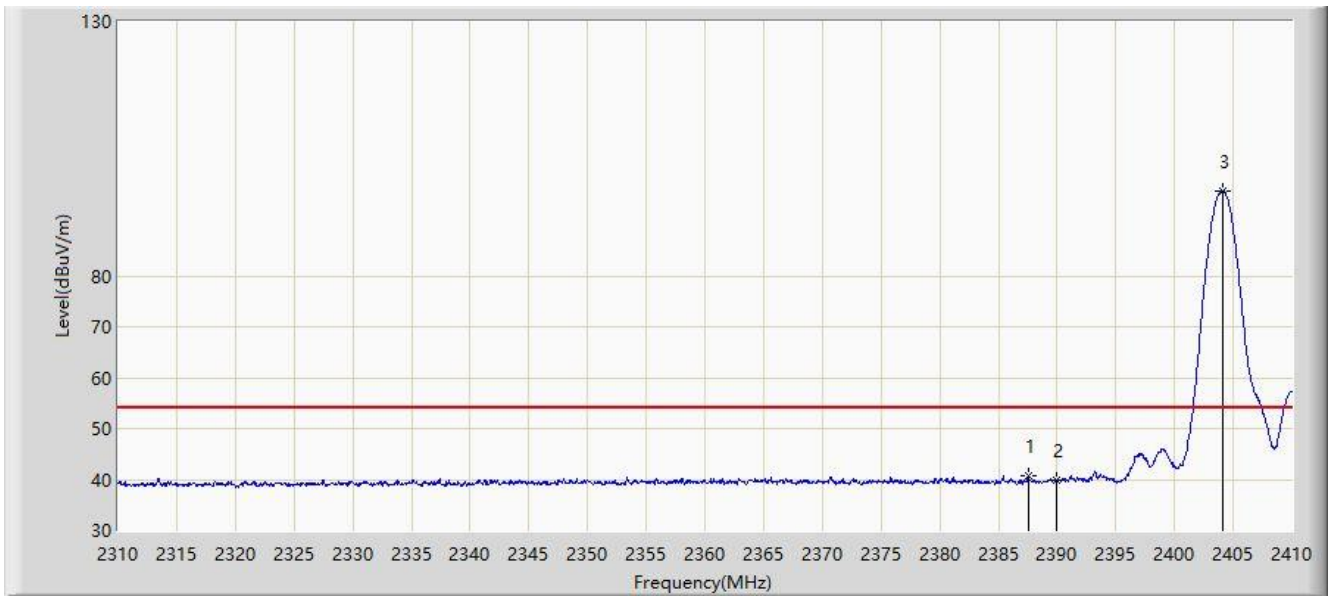

No	Flag	Mark	Frequency (MHz)	Measure Level (dBuV/m)	Reading Level (dBuV)	Margin (dB)	Limit (dBuV/m)	Factor (dB)	Type
1			2387.550	40.677	8.425	-13.323	54.000	32.251	AV
2			2390.000	39.887	7.622	-14.113	54.000	32.265	AV
3		*	2404.050	96.752	64.414	N/A	N/A	32.338	AV

Note: Measure Level (dB μ V/m) = Reading Level (dB μ V) + Factor (dB)

Factor (dB) = Cable Loss (dB) + Antenna Factor (dB/m).

Site: SIP-AC3	Time: 2021/07/14
Limit: FCC_Part15_15.209 RE(3m)	Engineer: Stephen Dong
Probe: SIP-AC3_HF907_102861_1-18GHz	Polarity: Vertical
EUT: Wireless Handheld Transmitter	Power: By Battery
Note: Transmit by Half Bandwidth at Channel 2404MHz	

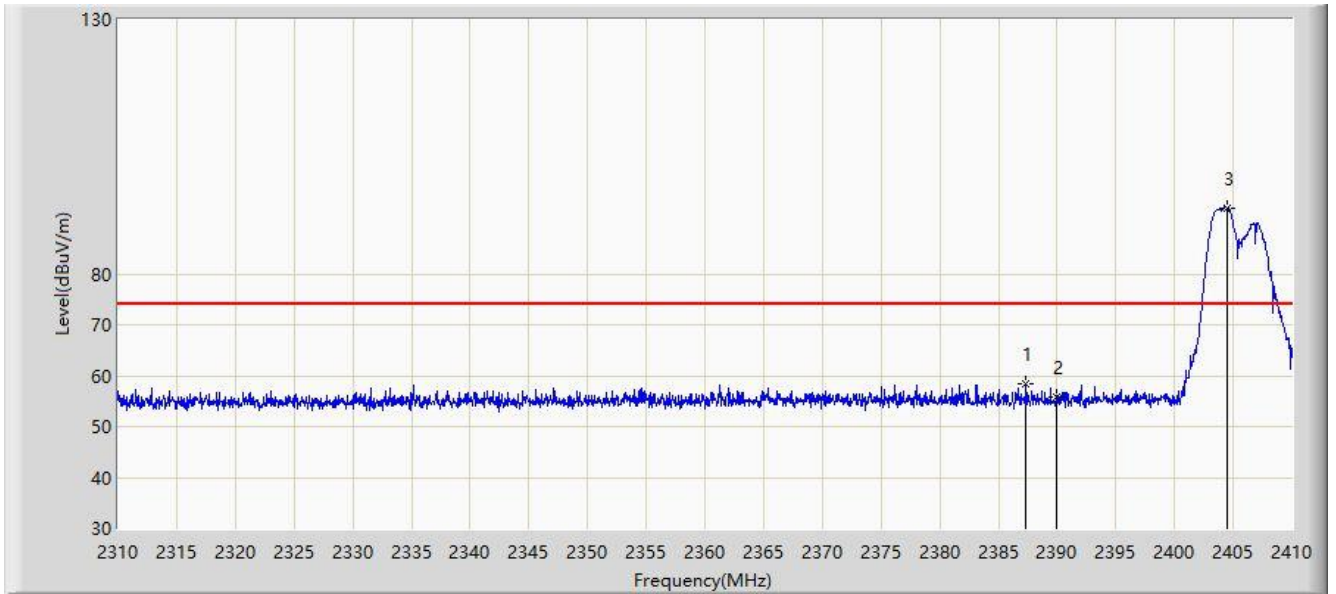

No	Flag	Mark	Frequency (MHz)	Measure Level (dBuV/m)	Reading Level (dBuV)	Margin (dB)	Limit (dBuV/m)	Factor (dB)	Type
1			2387.350	58.537	26.286	-15.463	74.000	32.251	PK
2			2390.000	55.877	23.612	-18.123	74.000	32.265	PK
3		*	2404.500	92.982	60.642	N/A	N/A	32.341	PK

Note: Measure Level (dB μ V/m) = Reading Level (dB μ V) + Factor (dB)

Factor (dB) = Cable Loss (dB) + Antenna Factor (dB/m).

Site: SIP-AC3	Time: 2021/07/14
Limit: FCC_Part15_15.209 RE(3m)	Engineer: Stephen Dong
Probe: SIP-AC3_HF907_102861_1-18GHz	Polarity: Vertical
EUT: Wireless Handheld Transmitter	Power: By Battery
Note: Transmit by Half Bandwidth at Channel 2404MHz	

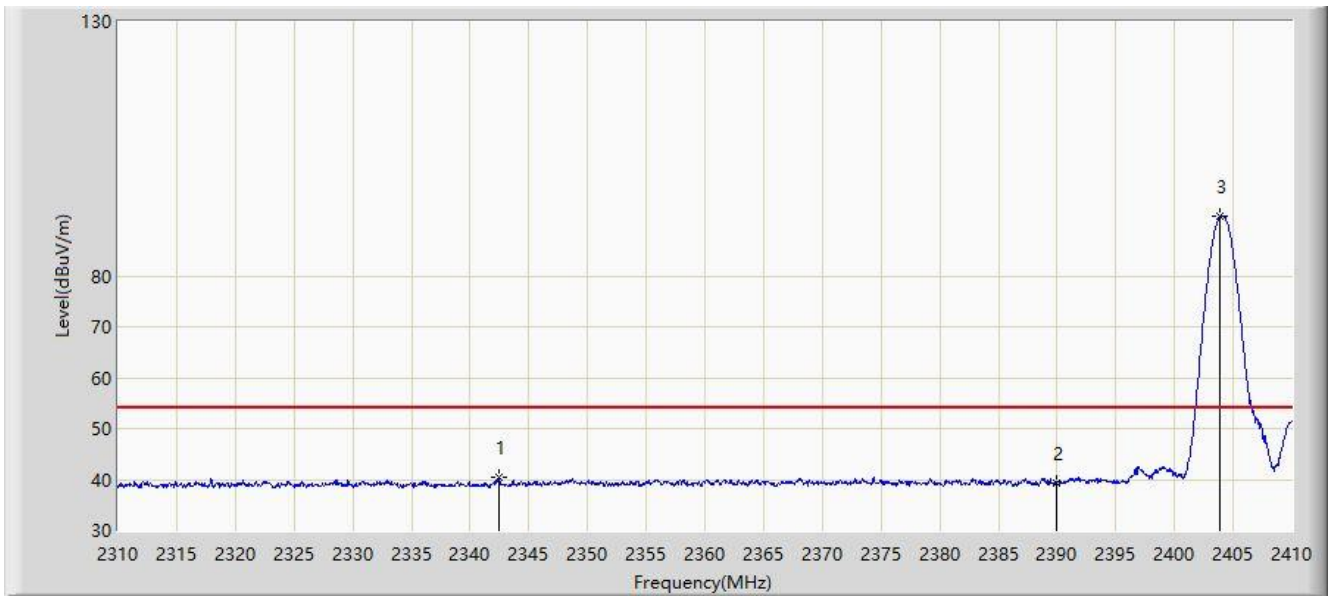

No	Flag	Mark	Frequency (MHz)	Measure Level (dBuV/m)	Reading Level (dBuV)	Margin (dB)	Limit (dBuV/m)	Factor (dB)	Type
1			2342.450	40.409	8.347	-13.591	54.000	32.062	AV
2			2390.000	39.333	7.068	-14.667	54.000	32.265	AV
3		*	2403.900	91.679	59.342	N/A	N/A	32.337	AV

Note: Measure Level (dB μ V/m) = Reading Level (dB μ V) + Factor (dB)

Factor (dB) = Cable Loss (dB) + Antenna Factor (dB/m).

Site: SIP-AC3	Time: 2021/07/14
Limit: FCC_Part15_15.209 RE(3m)	Engineer: Stephen Dong
Probe: SIP-AC3_HF907_102861_1-18GHz	Polarity: Horizontal
EUT: Wireless Handheld Transmitter	Power: By Battery
Note: Transmit by Half Bandwidth at Channel 2478MHz	

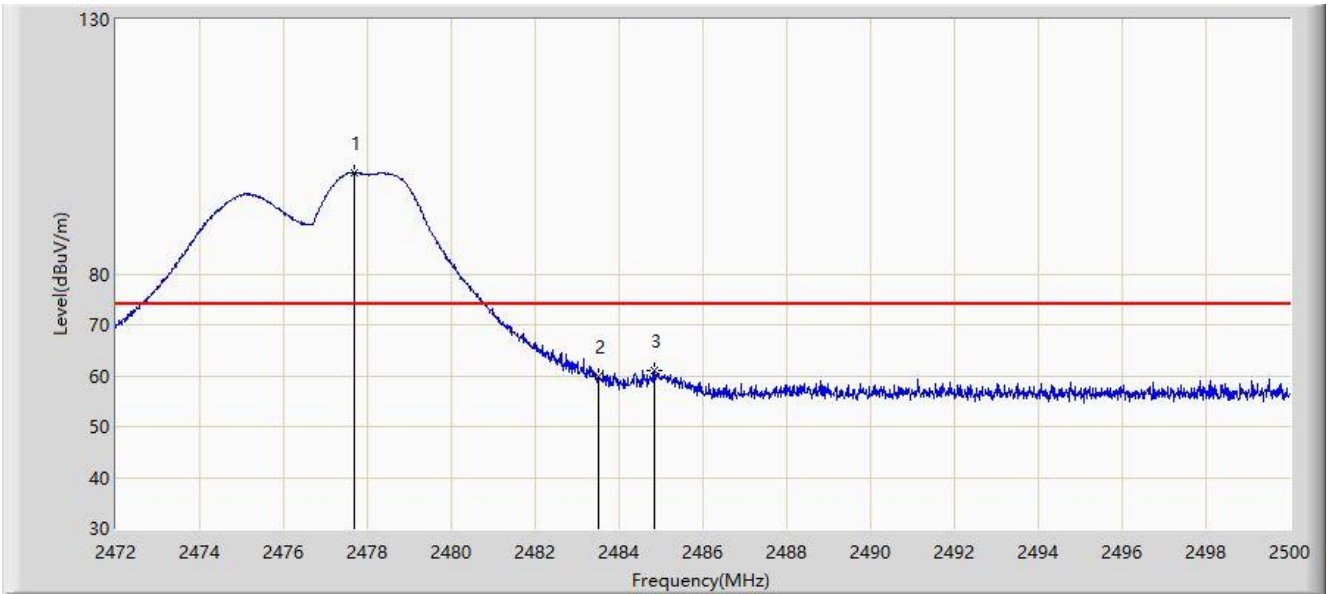

No	Flag	Mark	Frequency (MHz)	Measure Level (dBuV/m)	Reading Level (dBuV)	Margin (dB)	Limit (dBuV/m)	Factor (dB)	Type
1		*	2477.684	99.912	67.175	N/A	N/A	32.737	PK
2			2483.500	59.755	26.983	-14.245	74.000	32.772	PK
3			2484.838	60.996	28.216	-13.004	74.000	32.780	PK

Note: Measure Level (dB μ V/m) = Reading Level (dB μ V) + Factor (dB)

Factor (dB) = Cable Loss (dB) + Antenna Factor (dB/m).

Site: SIP-AC3	Time: 2021/07/14
Limit: FCC_Part15_15.209 RE(3m)	Engineer: Stephen Dong
Probe: SIP-AC3_HF907_102861_1-18GHz	Polarity: Horizontal
EUT: Wireless Handheld Transmitter	Power: By Battery
Note: Transmit by Half Bandwidth at Channel 2478MHz	

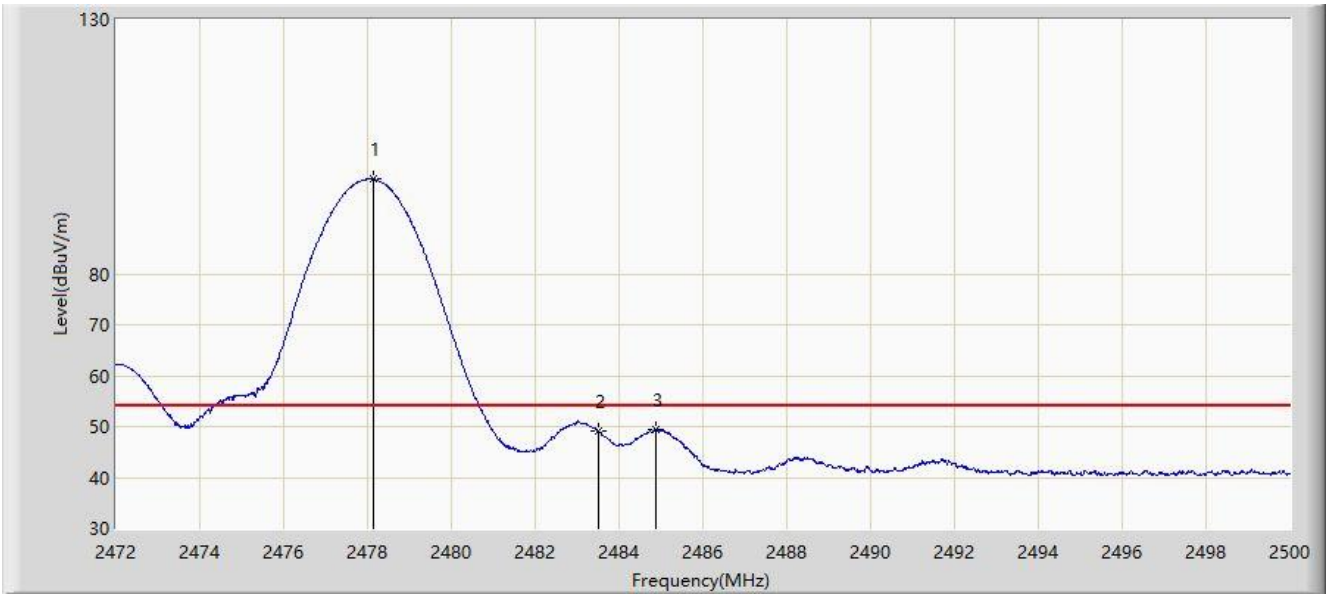

No	Flag	Mark	Frequency (MHz)	Measure Level (dBuV/m)	Reading Level (dBuV)	Margin (dB)	Limit (dBuV/m)	Factor (dB)	Type
1		*	2478.132	98.613	65.873	N/A	N/A	32.739	AV
2			2483.500	49.119	16.347	-4.881	54.000	32.772	AV
3			2484.880	49.488	16.708	-4.512	54.000	32.780	AV

Note: Measure Level (dB μ V/m) = Reading Level (dB μ V) + Factor (dB)

Factor (dB) = Cable Loss (dB) + Antenna Factor (dB/m).

Site: SIP-AC3	Time: 2021/07/14
Limit: FCC_Part15_15.209 RE(3m)	Engineer: Stephen Dong
Probe: SIP-AC3_HF907_102861_1-18GHz	Polarity: Vertical
EUT: Wireless Handheld Transmitter	Power: By Battery
Note: Transmit by Half Bandwidth at Channel 2478MHz	

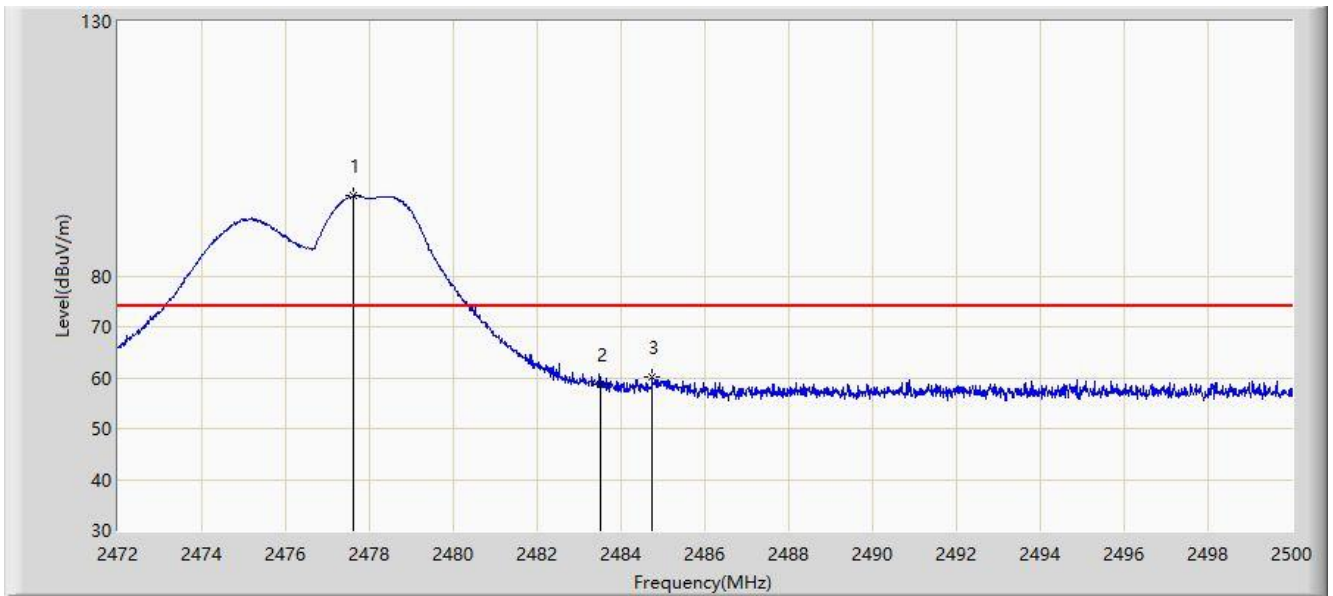

No	Flag	Mark	Frequency (MHz)	Measure Level (dBuV/m)	Reading Level (dBuV)	Margin (dB)	Limit (dBuV/m)	Factor (dB)	Type
1		*	2477.628	95.702	62.966	N/A	N/A	32.736	PK
2			2483.500	58.633	25.861	-15.367	74.000	32.772	PK
3			2484.740	60.067	27.288	-13.933	74.000	32.779	PK

Note: Measure Level (dBuV/m) = Reading Level (dBuV) + Factor (dB)

Factor (dB) = Cable Loss (dB) + Antenna Factor (dB/m).

Site: SIP-AC3	Time: 2021/07/14
Limit: FCC_Part15_15.209 RE(3m)	Engineer: Stephen Dong
Probe: SIP-AC3_HF907_102861_1-18GHz	Polarity: Vertical
EUT: Wireless Handheld Transmitter	Power: By Battery
Note: Transmit by Half Bandwidth at Channel 2478MHz	

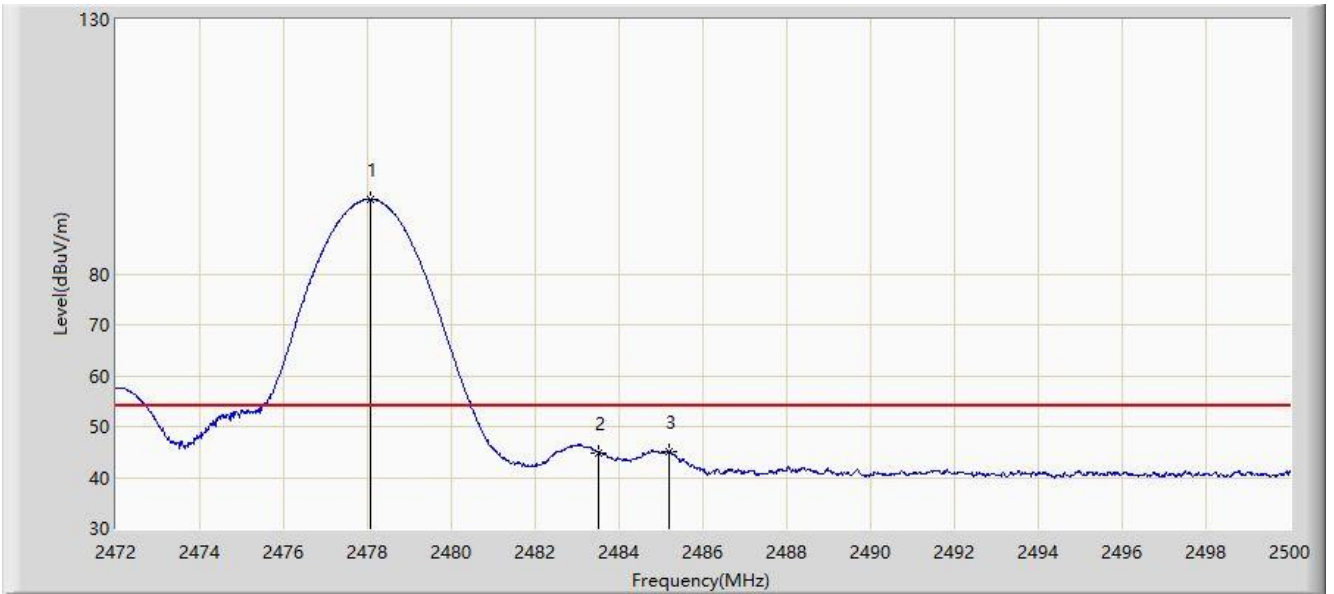

No	Flag	Mark	Frequency (MHz)	Measure Level (dBuV/m)	Reading Level (dBuV)	Margin (dB)	Limit (dBuV/m)	Factor (dB)	Type
1		*	2478.076	94.695	61.956	N/A	N/A	32.739	AV
2			2483.500	44.910	12.138	-9.090	54.000	32.772	AV
3			2485.188	45.113	12.331	-8.887	54.000	32.782	AV

Note: Measure Level (dB μ V/m) = Reading Level (dB μ V) + Factor (dB)

Factor (dB) = Cable Loss (dB) + Antenna Factor (dB/m).

6.8. AC Conducted Emissions Measurement

6.8.1. Test Limit

FCC Part 15 Subpart C Paragraph 15.207 Limits		
Frequency (MHz)	QP (dBuV)	AV (dBuV)
0.15 - 0.50	66 - 56	56 - 46
0.50 - 5.0	56	46
5.0 - 30	60	50

Note 1: The lower limit shall apply at the transition frequencies.

Note 2: The limit decreases linearly with the logarithm of the frequency in the range 0.15MHz to 0.5MHz.

6.8.2. Test Setup

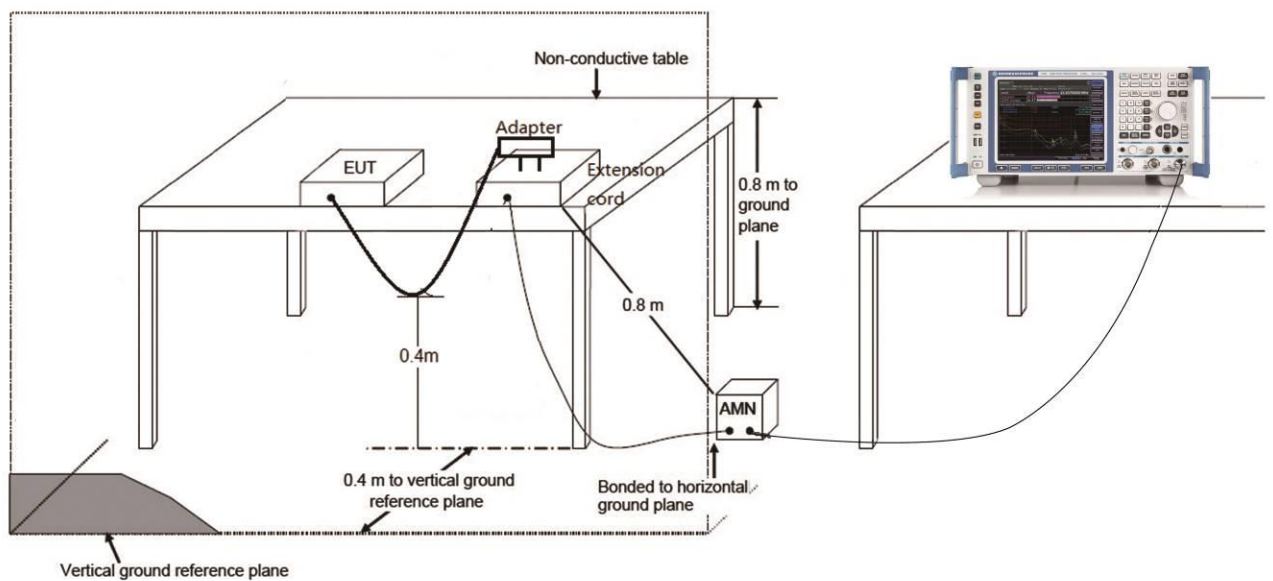

6.8.3. Test Result

Site: SIP-SR2	Time: 2021/07/10
Limit: FCC_Part15.207_CE_AC Power	Engineer: Kyrie Xie
Probe: SIP-SR2-ENV216_101684_With Connector	Polarity: Line
EUT: Wireless Handheld Transmitter	Power: AC 120V/60Hz
Note: Charging	

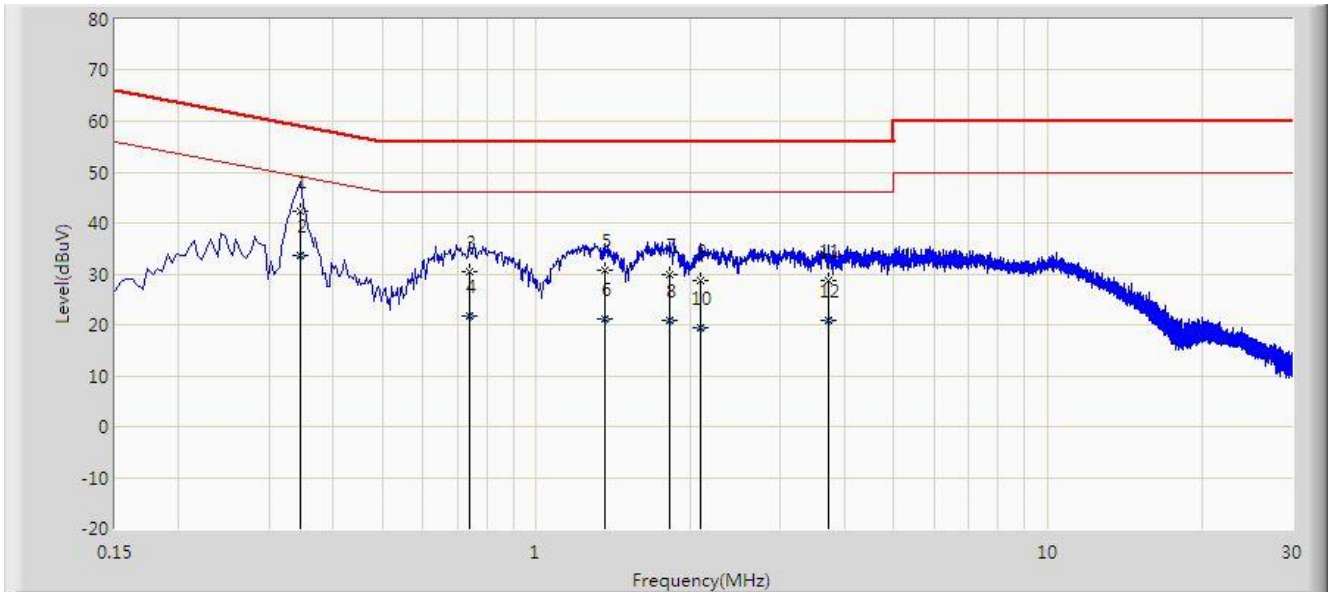

No	Flag	Mark	Frequency (MHz)	Measure Level (dBuV)	Reading Level (dBuV)	Margin (dB)	Limit (dBuV)	Factor (dB)	Type
1			0.346	42.301	32.757	-16.757	59.058	9.543	QP
2		*	0.346	33.619	24.075	-15.439	49.058	9.543	AV
3			0.738	30.375	20.815	-25.625	56.000	9.560	QP
4			0.738	21.709	12.149	-24.291	46.000	9.560	AV
5			1.358	30.629	21.069	-25.371	56.000	9.560	QP
6			1.358	21.154	11.594	-24.846	46.000	9.560	AV
7			1.818	29.991	20.421	-26.009	56.000	9.570	QP
8			1.818	20.808	11.238	-25.192	46.000	9.570	AV
9			2.090	28.746	19.173	-27.254	56.000	9.573	QP
10			2.090	19.348	9.774	-26.652	46.000	9.573	AV
11			3.722	28.569	18.881	-27.431	56.000	9.688	QP
12			3.722	20.980	11.292	-25.020	46.000	9.688	AV

Note: Measure Level (dBuV) = Reading Level (dBuV) + Factor (dB)

Factor (dB) = Cable Loss (dB) + LISN Factor (dB).

Site: SIP-SR2	Time: 2021/07/10
Limit: FCC_Part15.207_CE_AC Power	Engineer: Kyrie Xie
Probe: SIP-SR2-ENV216_101684_With Connector	Polarity: Neutral
EUT: Wireless Handheld Transmitter	Power: AC 120V/60Hz
Note: Charging	

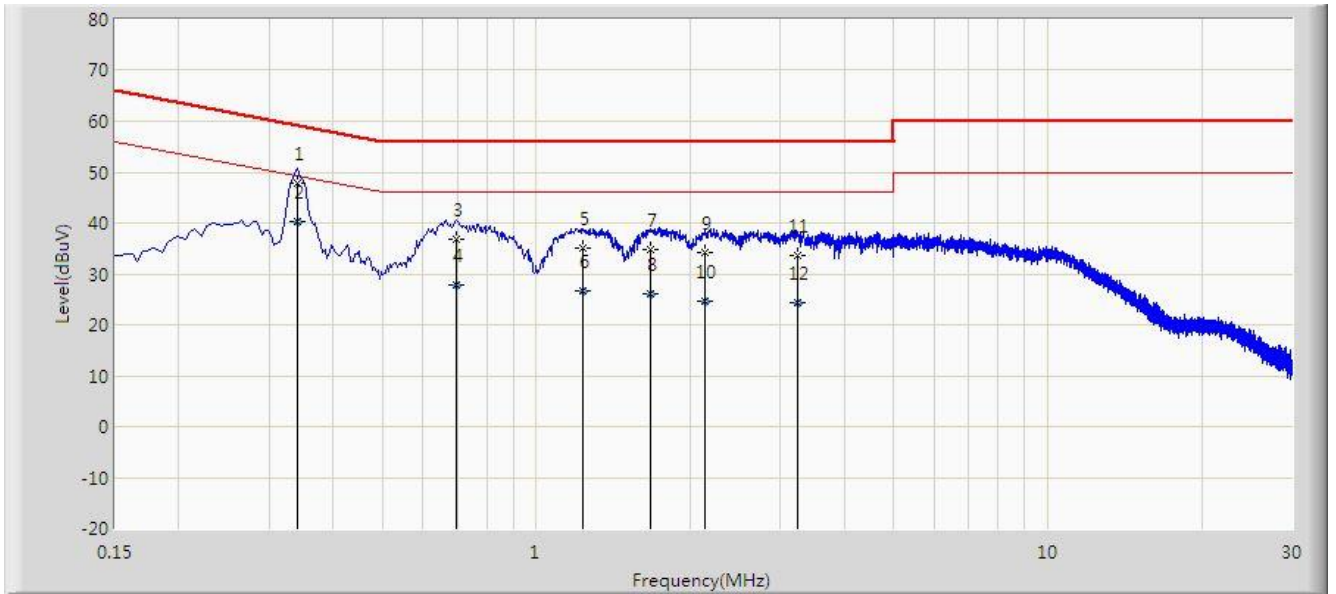

No	Flag	Mark	Frequency (MHz)	Measure Level (dBuV)	Reading Level (dBuV)	Margin (dB)	Limit (dBuV)	Factor (dB)	Type
1			0.342	47.946	38.422	-11.208	59.155	9.525	QP
2		*	0.342	40.351	30.826	-8.803	49.155	9.525	AV
3			0.698	36.746	27.206	-19.254	56.000	9.540	QP
4			0.698	27.808	18.268	-18.192	46.000	9.540	AV
5			1.230	35.101	25.559	-20.899	56.000	9.542	QP
6			1.230	26.703	17.161	-19.297	46.000	9.542	AV
7			1.670	34.643	25.086	-21.357	56.000	9.557	QP
8			1.670	26.017	16.460	-19.983	46.000	9.557	AV
9			2.142	34.282	24.719	-21.718	56.000	9.563	QP
10			2.142	24.759	15.196	-21.241	46.000	9.563	AV
11			3.234	33.560	23.922	-22.440	56.000	9.639	QP
12			3.234	24.488	14.849	-21.512	46.000	9.639	AV

Note: Measure Level (dBuV) = Reading Level (dBuV) + Factor (dB)

Factor (dB) = Cable Loss (dB) + LISN Factor (dB).

7. CONCLUSION

The data collected relate only the item(s) tested and show that the device is compliance with Part 15C of the FCC rules.

————— The End —————

Appendix A - Test Setup Photograph

Refer to "2106RSU074-UT" file.

Appendix B - EUT Photograph

Refer to "2106RSU074-UE" file.