

Necessary Bandwidth - STD Mode, 35mW, 470.125MHz

Step 1

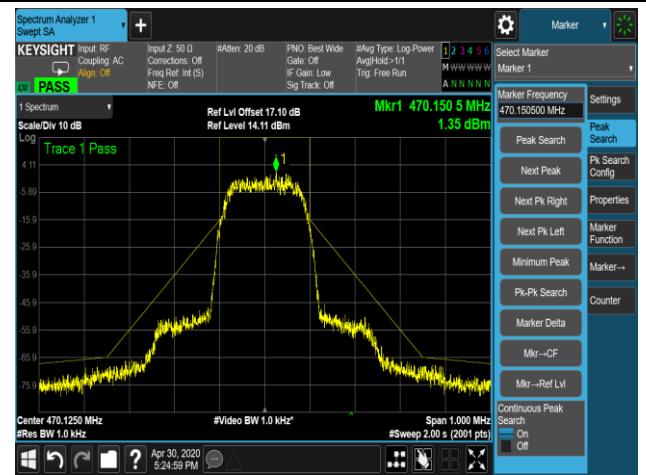

Step 2



Step 3

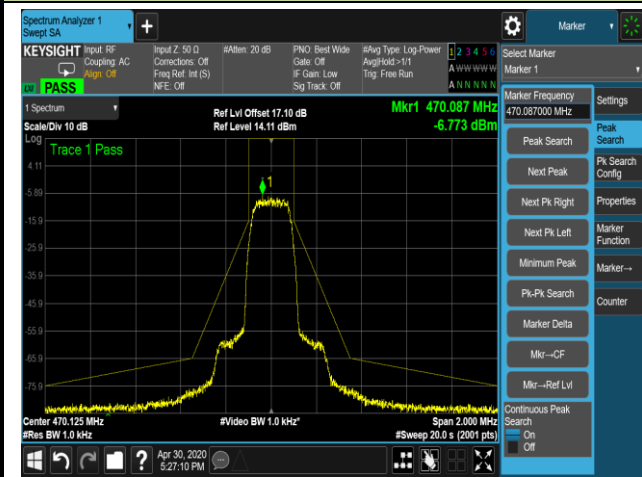

Necessary Bandwidth - STD Mode, 35mW, 539.000MHz

Step 1



Step 2

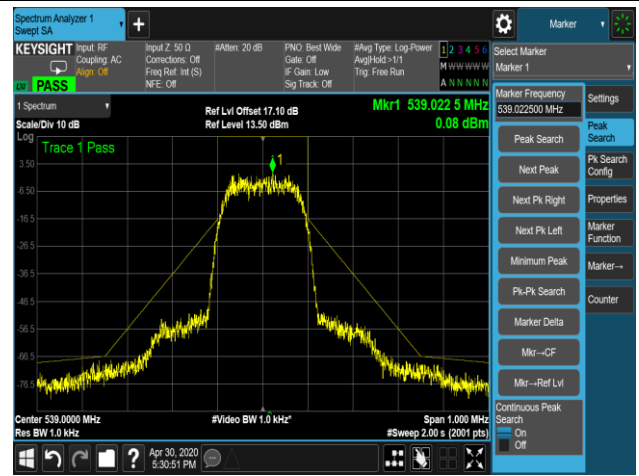

Step 3

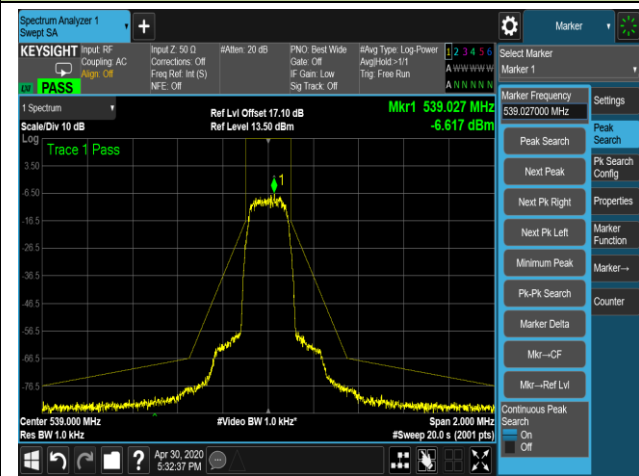

Necessary Bandwidth - STD Mode, 35mW, 607.875MHz

Step 1

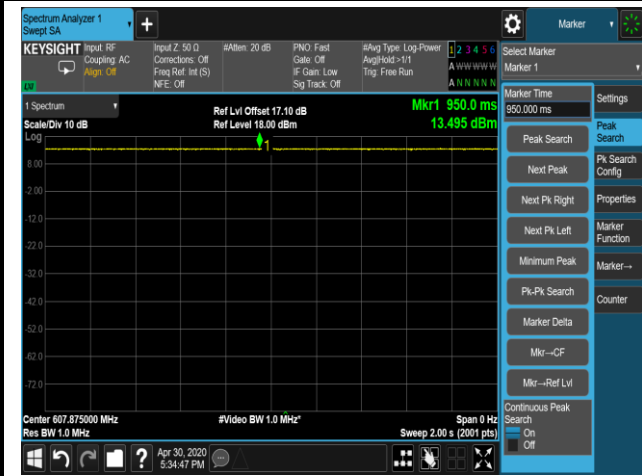

Step 2

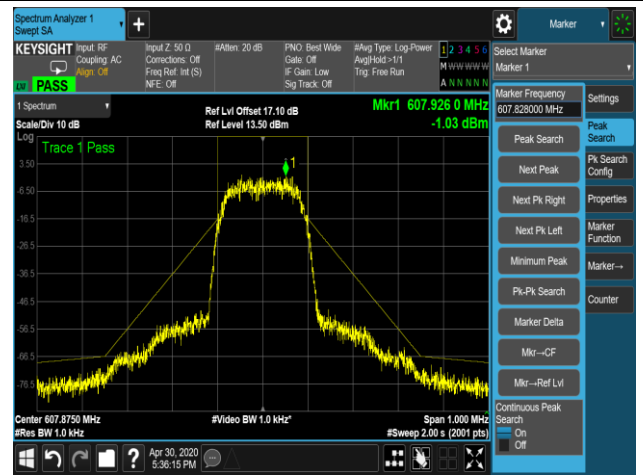

Step 3

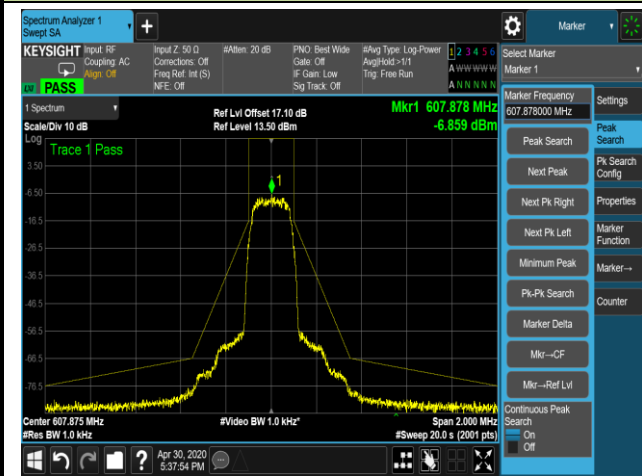

Necessary Bandwidth - HD Mode, 2mW, 470.125MHz

Step 1



Step 2

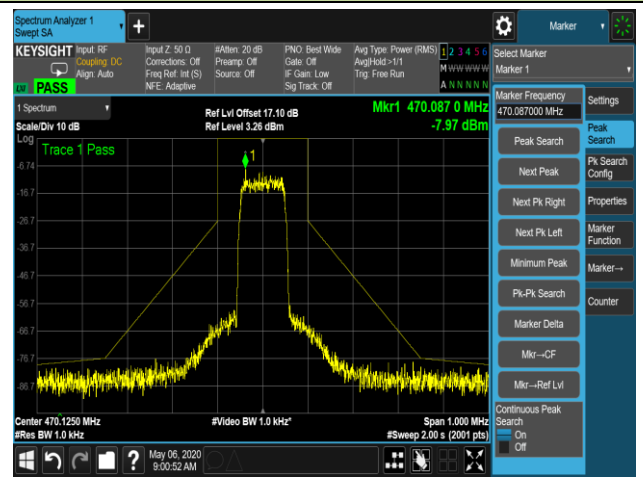

Step 3

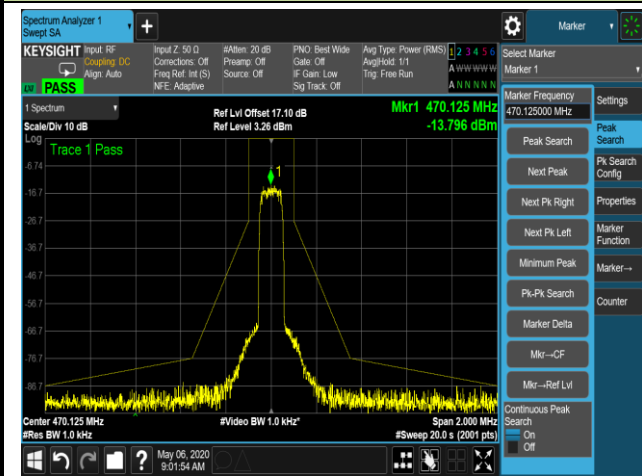

Necessary Bandwidth - HD Mode, 2mW, 539.000MHz

Step 1



Step 2

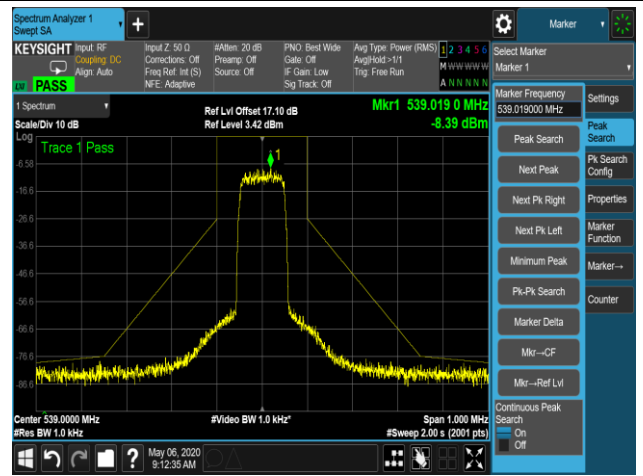

Step 3

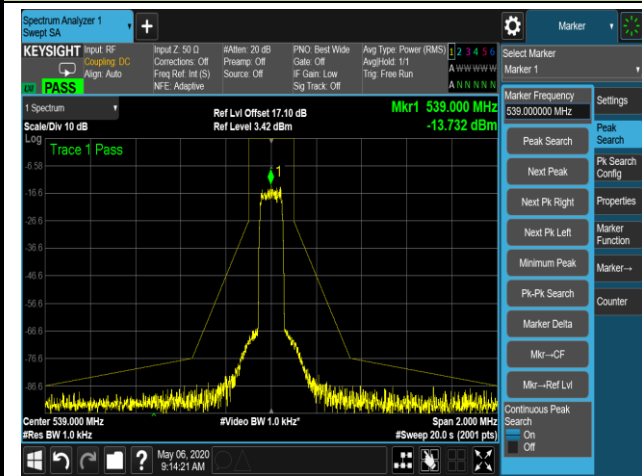

Necessary Bandwidth - HD Mode, 2mW, 607.875MHz

Step 1



Step 2

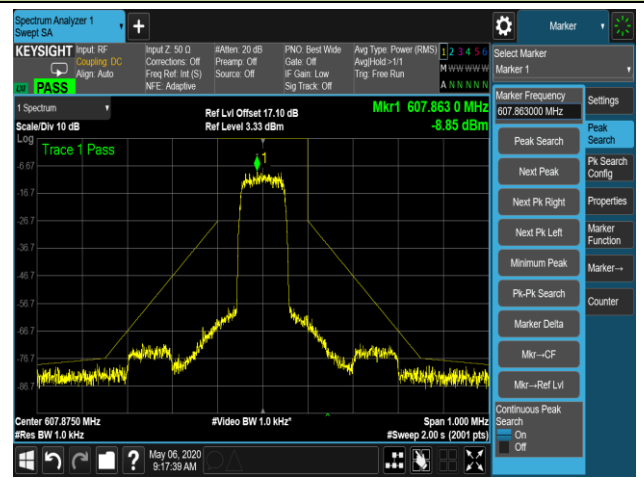

Step 3

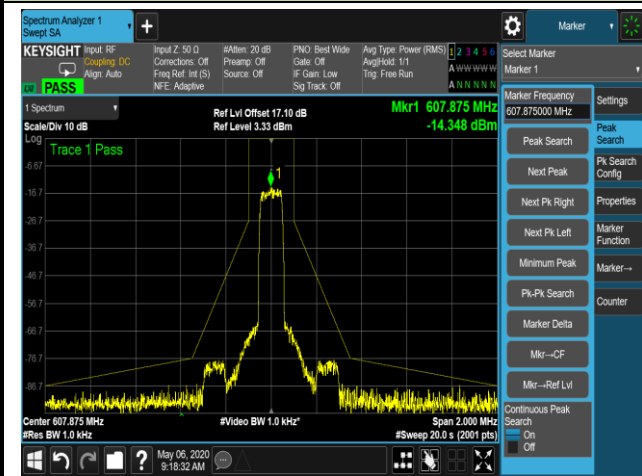

Necessary Bandwidth - HD Mode, 2mW, 615.875MHz

Step 1



Step 2

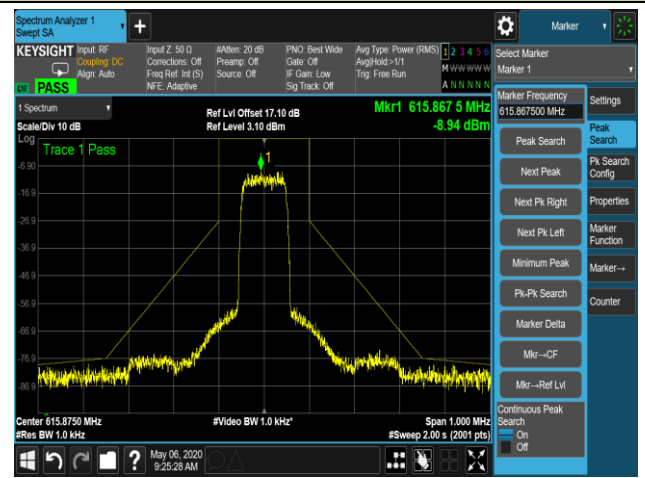

Step 3

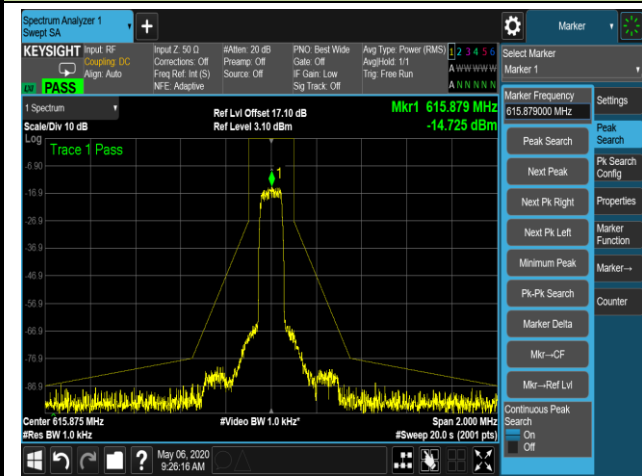

6.5. Output Power Measurement

6.5.1. Test Limit

In the bands allocated and assigned for broadcast television and in the 600 MHz service band: 50 mW EIRP.

In the 600 MHz guard band and the 600 MHz duplex gap: 20 mW EIRP.

6.5.2. Test Procedure Used

N/A

6.5.3. Test Setting

Radiated Measurement

The EUT was set to transmit on the bottom, middle, and top frequencies in each power level.

All significant broadband and narrowband signals found in the preliminary sweeps were measured using a peak detector at a test distance of 3 meters.

Allow trace to fully stabilize and use the peak search function on the instrument to find the peak of the spectrum, then mathematically convert the measured field strength level to an equivalent power level for comparison to the applicable limit.

Conducted Measurement

The EUT was set to transmit on the bottom, middle, and top frequencies in each power level.

All significant broadband and narrowband signals found in the preliminary sweeps were measured using a peak detector at a test distance of 3 meters.

Allow trace to fully stabilize and use the peak search function on the instrument to find the peak of the spectrum.

6.5.4. Test Setup

Radiated Measurement

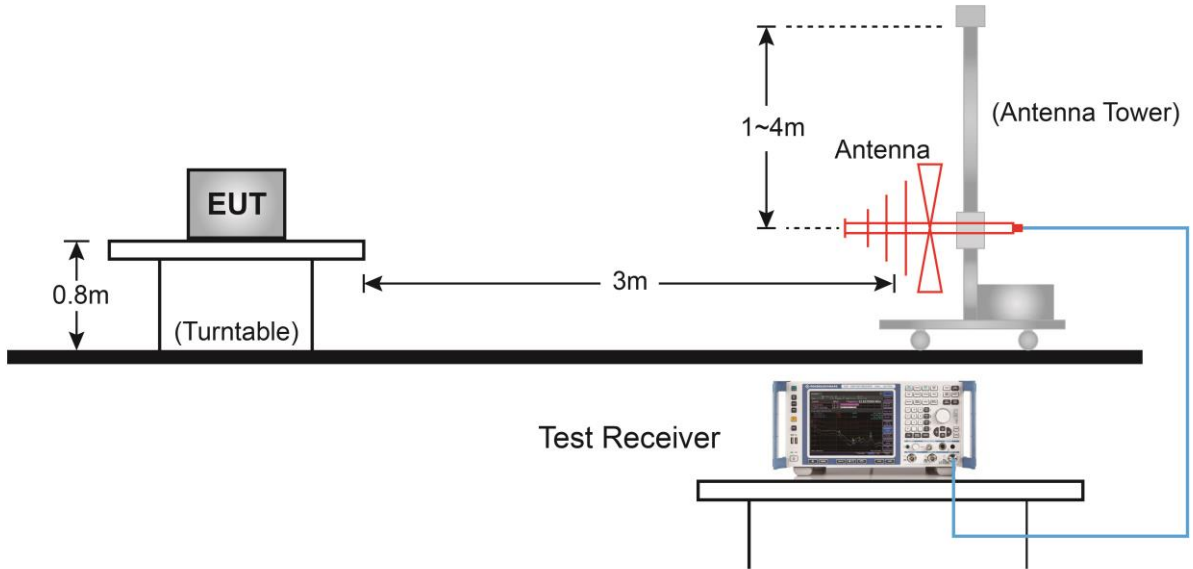

Conducted Measurement

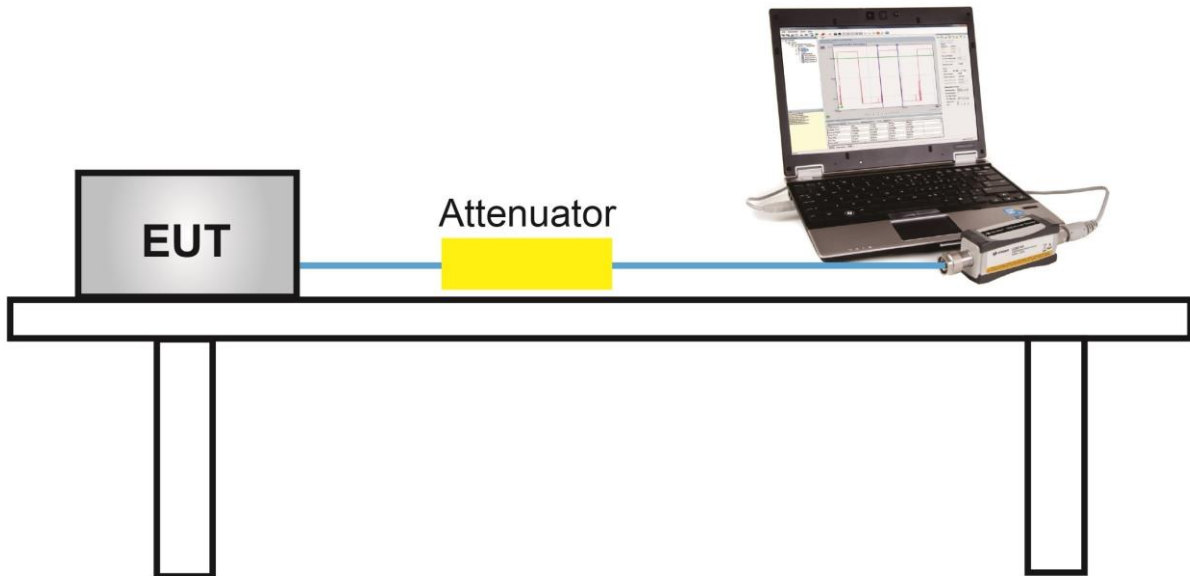

6.5.5. Test Result

Test Engineer	Buter Shi	Temperature	25°C
Test Site	AC1	Relative Humidity	44 ~ 68%
Model No.	AD3 G57+	Test Date	2020/05/11

Frequency (MHz)	Measurement Level (dBuV/m)	Factor (dB)	EIRP (dBm)	Limit (dBm)	Test Result
STD Mode (35mW)					
470.125	109.44	95.2	14.24	16.99	Pass
539.000	110.42	95.2	15.22	16.99	Pass
607.875	111.33	95.2	16.13	16.99	Pass
STD Mode (10mW)					
614.125	105.10	95.2	9.90	13.01	Pass
615.875	104.89	95.2	9.80	13.01	Pass
HD Mode (2mW)					
470.125	96.23	95.2	1.03	16.99	Pass
539.000	100.85	95.2	5.65	16.99	Pass
607.875	99.97	95.2	4.77	16.99	Pass
614.125	99.50	95.2	4.30	13.01	Pass
615.875	98.96	95.2	4.27	13.01	Pass

Note 1: Limit = $10 \cdot \log(50\text{mW}) = 16.99 \text{ dBm}$.

Note 2: Limit = $10 \cdot \log(20\text{mW}) = 13.01 \text{ dBm}$.

Note 3: EIRP (dBm) = Measurement Level (dBuV/m) - Factor (dB).

Test Result of Average Output Power (Reporting Only)

Frequency (MHz)	Conducted Output Power (dBm)	
	STD Mode - 35mW	HD Mode - 2mW
470.125	15.12	4.76
539.000	15.07	4.23
607.875	14.74	3.40
Frequency (MHz)	Conducted Output Power (dBm)	
	STD Mode - 10mW	HD Mode - 2mW
614.125	9.74	3.41
615.875	9.63	3.36

6.6. Radiated Spurious Emission Measurement

6.6.1. Test Limit

According to FCC Part 15.236(g), emissions outside of this band shall comply with the limits specified in section 8.4 of ETSI EN 300 422-1 V1.4.2.

State	Frequency		
	47MHz to 74MHz, 87.5MHz to 137MHz 174MHz to 230MHz, 470MHz to 862MHz	Other Frequencies below 1000MHz	Frequencies above 1000MHz
Operation	4nW	250nW	1uW
Standby	2nW	2nW	20nW

6.6.2. Test Procedure Used

ETSI EN 300 422-1 V1.4.2 clause 8.4.2.

6.6.3. Test Setting

Table 1 - RBW as a function of frequency

Frequency	RBW
25 ~ 30 MHz	9 kHz
30 ~ 1000 MHz	100 kHz
1000 ~ 6000 MHz	1 MHz

Emissions shall be investigated up to the 10th harmonic of the fundamental.

All the emissions shall be demonstrated using a QP detector below 1 GHz and an RMS Average detector above 1 GHz.

All significant broadband and narrowband signals found in the preliminary sweeps were measured using a peak detector at a test distance of 3 meters.

at each frequency at which a component is detected, the sample shall be rotated to obtain maximum response and the effective radiated power of that component determined by a substitution measurement.

6.6.4. Test Setup

Below 1GHz Test Setup:

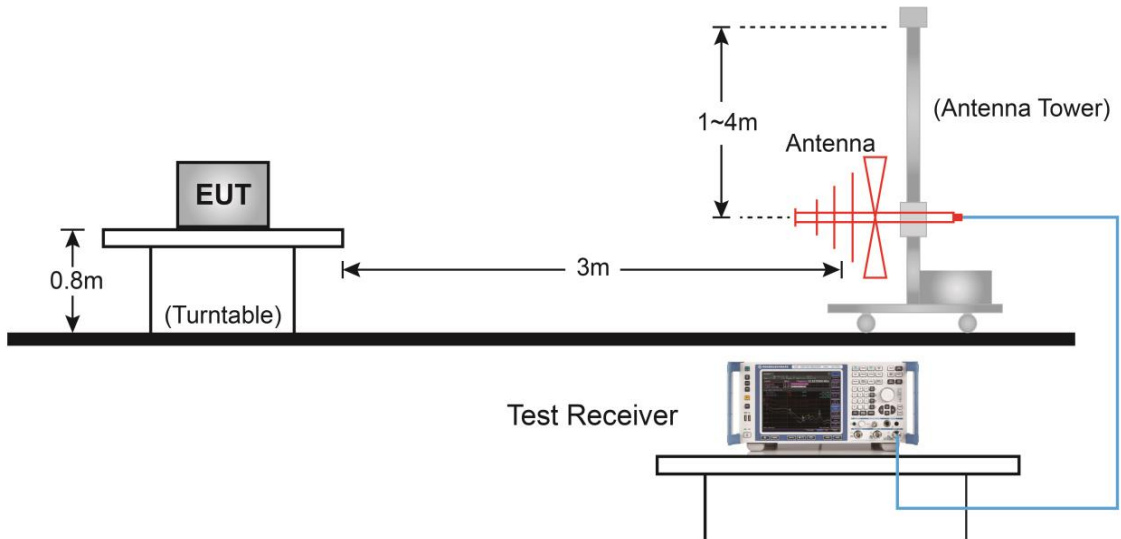

Above 1GHz Test Setup:

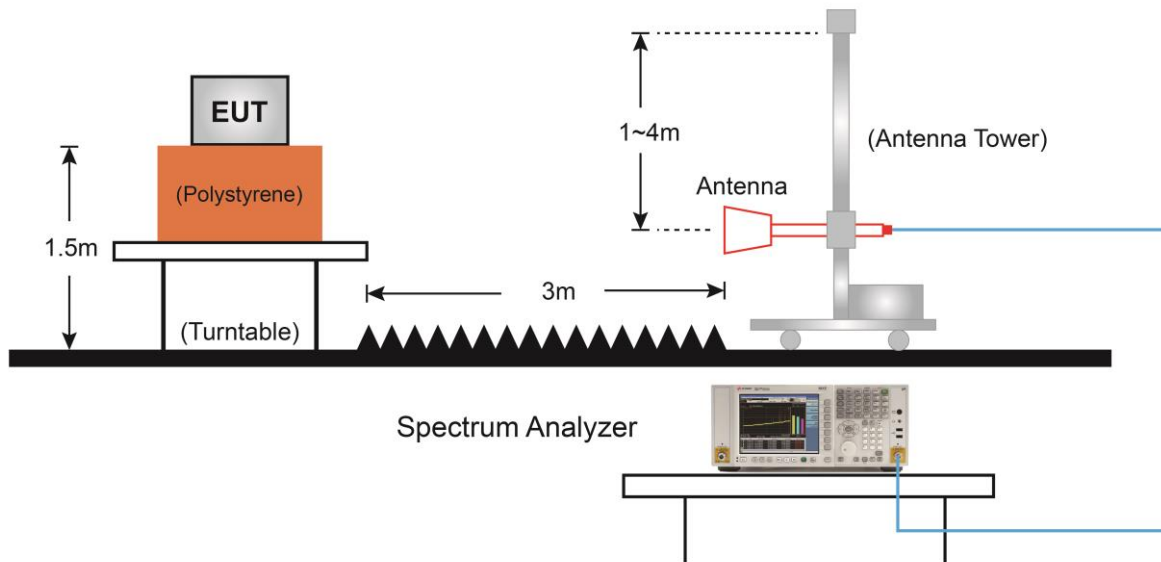

6.6.5. Test Result

Test Site	AC1	Temperature	25°C
Test Engineer	Buter Shi	Relative Humidity	54%
Test Mode	STD Mode - 35mW	Test Date	2020/05/16

Test Channel (MHz)	Frequency (MHz)	Ant. Pol. (H/V)	SG Reading (dBm)	Cable Loss (dB)	Substitute Antenna Gain (dBi)	EIRP (dBm)	Limit (dBm)	Margin (dB)
470.125	1410.4	H	-64.5	0.5	7.1	-57.9	-30.0	-27.9
	1880.5	H	-68.7	0.6	10.1	-59.2	-30.0	-29.2
	3761.0	H	-67.5	0.8	12.3	-56.0	-30.0	-26.0
	1410.4	V	-64.2	0.5	7.1	-57.6	-30.0	-27.6
	1880.5	V	-69.1	0.6	10.1	-59.6	-30.0	-29.6
	3761.0	V	-67.0	0.8	12.3	-55.5	-30.0	-25.5
539.000	2156.0	H	-66.2	0.6	9.3	-57.5	-30.0	-27.5
	2695.0	H	-67.0	0.7	11.1	-56.6	-30.0	-26.6
	4312.0	H	-67.9	0.8	12.7	-56.0	-30.0	-26.0
	2156.0	V	-66.5	0.6	9.3	-57.8	-30.0	-27.8
	2695.0	V	-67.3	0.7	11.1	-56.9	-30.0	-26.9
	4312.0	V	-68.4	0.8	12.7	-56.5	-30.0	-26.5
607.875	1823.6	H	-67.8	0.6	9.9	-58.5	-30.0	-28.5
	2431.5	H	-66.3	0.6	10.4	-56.5	-30.0	-26.5
	4863.0	H	-66.6	0.9	12.7	-54.8	-30.0	-24.8
	1823.6	V	-68.7	0.6	9.9	-59.4	-30.0	-29.4
	2431.5	V	-67.4	0.6	10.4	-57.6	-30.0	-27.6
	4863.0	V	-66.1	0.9	12.7	-54.3	-30.0	-24.3

Note 1: $EIRP (dBm) = SG \text{ Reading (dBm)} - Cable \text{ Loss (dB)} + Substitute \text{ Antenna Gain (dBi)}$

Note 2: $Margin (dB) = EIRP (dBm) - Limit (dBm)$

Note 3: All data in this table is based on peak detection. Due to peak detection will yield amplitudes equal to or greater than amplitudes measured with the quasi-peak and RMS detector. Thus, the data measured using the peak detector of a spectrum analyzer or EMI receiver will represent the worst-case results.

Test Site	AC1	Temperature	25°C
Test Engineer	Buter Shi	Relative Humidity	54%
Test Mode	STD Mode - 10mW	Test Date	2020/05/16

Test Channel (MHz)	Frequency (MHz)	Ant. Pol. (H/V)	SG Reading (dBm)	Cable Loss (dB)	Substitute Antenna Gain (dBi)	EIRP (dBm)	Limit (dBm)	Margin (dB)
614.125	1842.4	H	-68.9	0.6	10.0	-59.5	-30.0	-29.5
	2456.5	H	-67.4	0.6	10.5	-57.5	-30.0	-27.5
	4913.0	H	-66.5	0.9	12.7	-54.7	-30.0	-24.7
	1842.4	V	-68.5	0.6	10.0	-59.1	-30.0	-29.1
	2456.5	V	-66.6	0.6	10.5	-56.7	-30.0	-26.7
	4913.0	V	-66.3	0.9	12.7	-54.5	-30.0	-24.5
615.875	1847.6	H	-67.6	0.6	10.0	-58.2	-30.0	-28.2
	2463.5	H	-65.1	0.6	10.6	-55.1	-30.0	-25.1
	3695.3	H	-67.2	0.8	12.2	-55.8	-30.0	-25.8
	1847.6	V	-67.6	0.6	10.0	-58.2	-30.0	-28.2
	2463.5	V	-65.1	0.6	10.6	-55.1	-30.0	-25.1
	3695.3	V	-67.2	0.8	12.2	-55.8	-30.0	-25.8

Note 1: $EIRP (dBm) = SG \text{ Reading (dBm)} - Cable \text{ Loss (dB)} + Substitute \text{ Antenna Gain (dBi)}$

Note 2: $Margin (dB) = EIRP (dBm) - Limit (dBm)$

Note 3: All data in this table is based on peak detection. Due to peak detection will yield amplitudes equal to or greater than amplitudes measured with the quasi-peak and RMS detector. Thus, the data measured using the peak detector of a spectrum analyzer or EMI receiver will represent the worst-case results.

Test Site	AC1	Temperature	25°C
Test Engineer	Buter Shi	Relative Humidity	54%
Test Mode	HD Mode - 2mW	Test Date	2020/05/16

Test Channel (MHz)	Frequency (MHz)	Ant. Pol. (H/V)	SG Reading (dBm)	Cable Loss (dB)	Substitute Antenna Gain (dBi)	EIRP (dBm)	Limit (dBm)	Margin (dB)
470.125	1410.4	H	-64.6	0.5	7.1	-58.0	-30.0	-28.0
	1880.5	H	-69.2	0.6	10.1	-59.7	-30.0	-29.7
	3761.0	H	-67.0	0.8	12.3	-55.5	-30.0	-25.5
	1410.4	V	-64.0	0.5	7.1	-57.4	-30.0	-27.4
	1880.5	V	-68.8	0.6	10.1	-59.3	-30.0	-29.3
	3761.0	V	-67.4	0.8	12.3	-55.9	-30.0	-25.9
539.000	2156.0	H	-65.8	0.6	9.3	-57.1	-30.0	-27.1
	2695.0	H	-67.9	0.7	11.1	-57.5	-30.0	-27.5
	4312.0	H	-67.9	0.8	12.7	-56.0	-30.0	-26.0
	2156.0	V	-66.1	0.6	9.3	-57.4	-30.0	-27.4
	2695.0	V	-66.8	0.7	11.1	-56.4	-30.0	-26.4
	4312.0	V	-67.4	0.8	12.7	-55.5	-30.0	-25.5
607.875	1823.6	H	-67.5	0.6	9.9	-58.2	-30.0	-28.2
	2431.5	H	-65.4	0.6	10.4	-55.6	-30.0	-25.6
	4863.0	H	-66.1	0.9	12.7	-54.3	-30.0	-24.3
	1823.6	V	-68.8	0.6	9.9	-59.5	-30.0	-29.5
	2431.5	V	-67.2	0.6	10.4	-57.4	-30.0	-27.4
	4863.0	V	-66.3	0.9	12.7	-54.5	-30.0	-24.5

Note 1: $EIRP (dBm) = SG \text{ Reading (dBm)} - Cable \text{ Loss (dB)} + Substitute \text{ Antenna Gain (dBi)}$

Note 2: $Margin (dB) = EIRP (dBm) - Limit (dBm)$

Note 3: All data in this table is based on peak detection. Due to peak detection will yield amplitudes equal to or greater than amplitudes measured with the quasi-peak and RMS detector. Thus, the data measured using the peak detector of a spectrum analyzer or EMI receiver will represent the worst-case results.

Test Site	AC1	Temperature	25°C
Test Engineer	Buter Shi	Relative Humidity	54%
Test Mode	HD Mode - 2mW	Test Date	2020/05/16

Test Channel (MHz)	Frequency (MHz)	Ant. Pol. (H/V)	SG Reading (dBm)	Cable Loss (dB)	Substitute Antenna Gain (dBi)	EIRP (dBm)	Limit (dBm)	Margin (dB)
614.125	1842.4	H	-68.5	0.6	10.0	-59.1	-30.0	-29.1
	2456.5	H	-67.3	0.6	10.5	-57.4	-30.0	-27.4
	4913.0	H	-66.6	0.9	12.7	-54.8	-30.0	-24.8
	1842.4	V	-68.7	0.6	10.0	-59.3	-30.0	-29.3
	2456.5	V	-65.5	0.6	10.5	-55.6	-30.0	-25.6
	4913.0	V	-66.4	0.9	12.7	-54.6	-30.0	-24.6
615.875	1847.6	H	-68.5	0.6	10.0	-59.1	-30.0	-29.1
	2463.5	H	-68.2	0.6	10.6	-58.2	-30.0	-28.2
	3695.3	H	-67.8	0.8	12.2	-56.4	-30.0	-26.4
	1847.6	V	-68.5	0.6	10.0	-59.1	-30.0	-29.1
	2463.5	V	-67.4	0.6	10.6	-57.4	-30.0	-27.4
	3695.3	V	-67.7	0.8	12.2	-56.3	-30.0	-26.3

Note 1: $EIRP (dBm) = SG \text{ Reading (dBm)} - Cable \text{ Loss (dB)} + Substitute \text{ Antenna Gain (dBi)}$

Note 2: $Margin (dB) = EIRP (dBm) - Limit (dBm)$

Note 3: All data in this table is based on peak detection. Due to peak detection will yield amplitudes equal to or greater than amplitudes measured with the quasi-peak and RMS detector. Thus, the data measured using the peak detector of a spectrum analyzer or EMI receiver will represent the worst-case results.

6.7. AC Conducted Emissions Measurement

6.7.1. Test Limit

FCC Part 15 Subpart C Paragraph 15.207 Limits		
Frequency (MHz)	QP (dB μ V)	Average (dB μ V)
0.15 - 0.50	66 - 56	56 - 46
0.50 - 5.0	56	46
5.0 - 30	60	50

Note 1: The lower limit shall apply at the transition frequencies.

Note 2: The limit decreases linearly with the logarithm of the frequency in the range 0.15MHz to 0.5MHz.

6.7.2. Test Setup

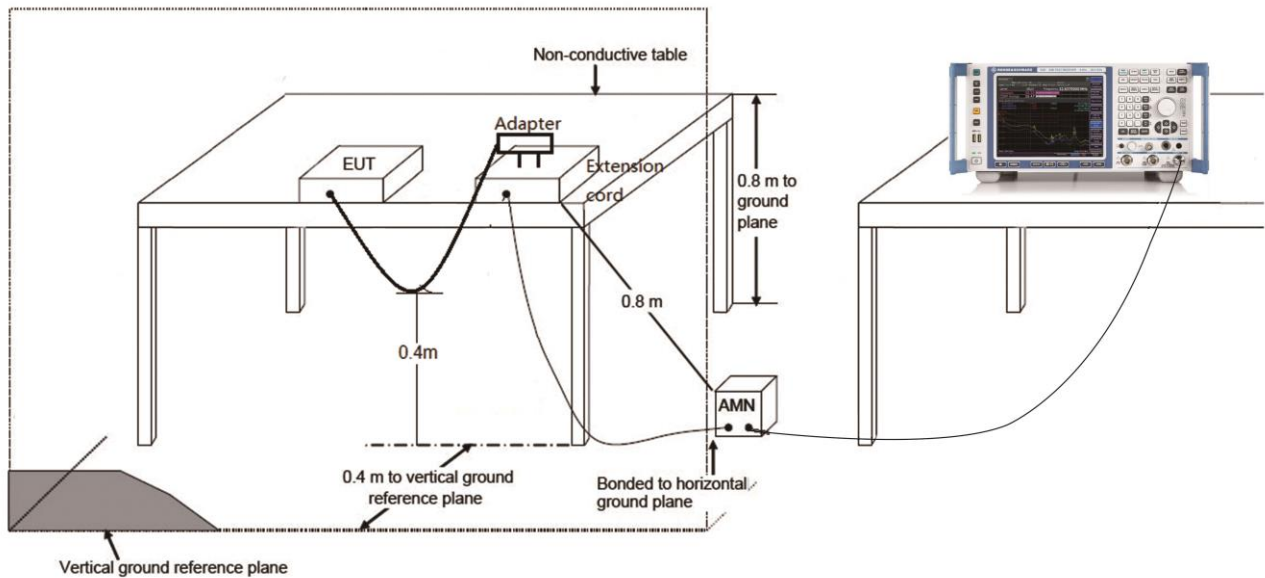

6.7.3. Test Result of Conducted Emissions

Site: SR2	Time: 2020/05/26 - 14:37
Limit: FCC_Part15.207_CE_AC Power	Engineer: Messiah Li
Probe: ENV216_101684_Filter On	Polarity: Line
EUT: Digital Plug-on Transmitter	Power: AC 120V/60Hz
Note: STD mode, 35mW, Transmit at 470.125MHz	

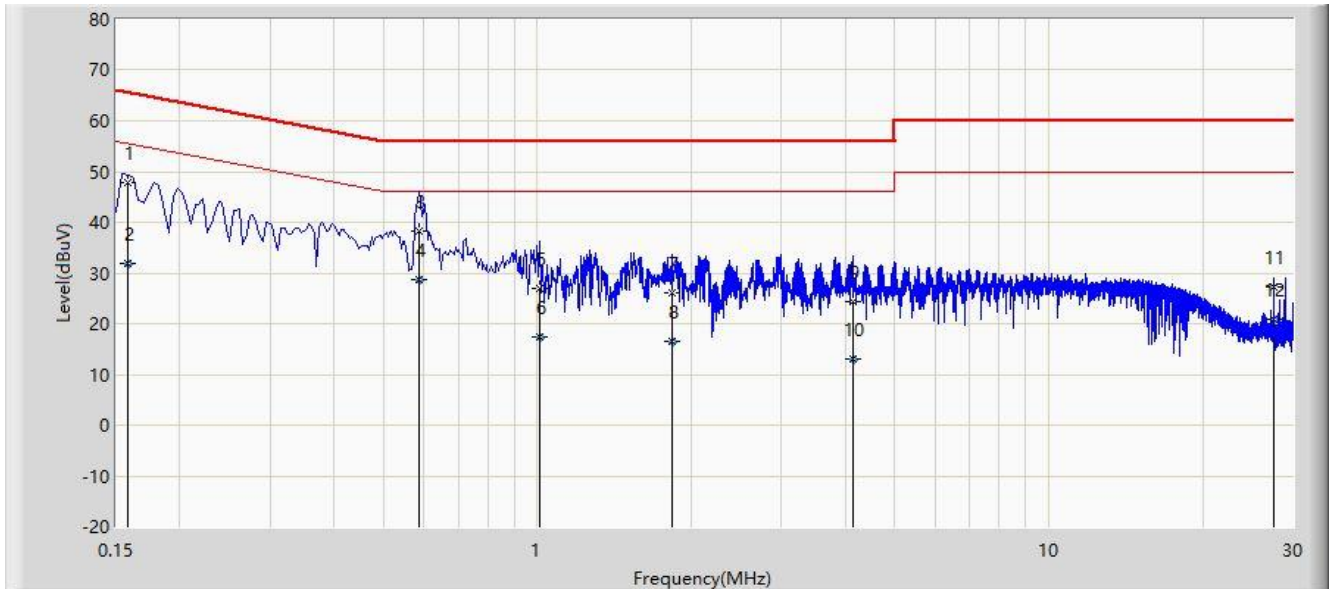

No	Flag	Mark	Frequency (MHz)	Measure Level (dBuV)	Reading Level (dBuV)	Margin (dB)	Limit (dBuV)	Factor (dB)	Type
1			0.158	47.867	37.586	-17.701	65.568	10.281	QP
2			0.158	31.748	21.467	-23.820	55.568	10.281	AV
3			0.586	38.137	27.992	-17.863	56.000	10.146	QP
4		*	0.586	28.670	18.524	-17.330	46.000	10.146	AV
5			1.010	27.027	17.072	-28.973	56.000	9.956	QP
6			1.010	17.369	7.413	-28.631	46.000	9.956	AV
7			1.834	26.055	16.115	-29.945	56.000	9.940	QP
8			1.834	16.385	6.445	-29.615	46.000	9.940	AV
9			4.146	24.344	14.468	-31.656	56.000	9.876	QP
10			4.146	13.119	3.243	-32.881	46.000	9.876	AV
11			27.498	27.219	17.094	-32.781	60.000	10.125	QP
12			27.498	21.007	10.882	-28.993	50.000	10.125	AV

Note: Measure Level (dBuV) = Reading Level (dBuV) + Factor (dB)

Factor (dB) = Cable Loss (dB) + LISN Factor (dB)

Site: SR2	Time: 2020/05/26 - 14:41
Limit: FCC_Part15.207_CE_AC Power	Engineer: Messiah Li
Probe: ENV216_101684_Filter On	Polarity: Neutral
EUT: Digital Plug-on Transmitter	Power: AC 120V/60Hz
Note: STD mode, 35mW, Transmit at 470.125MHz	

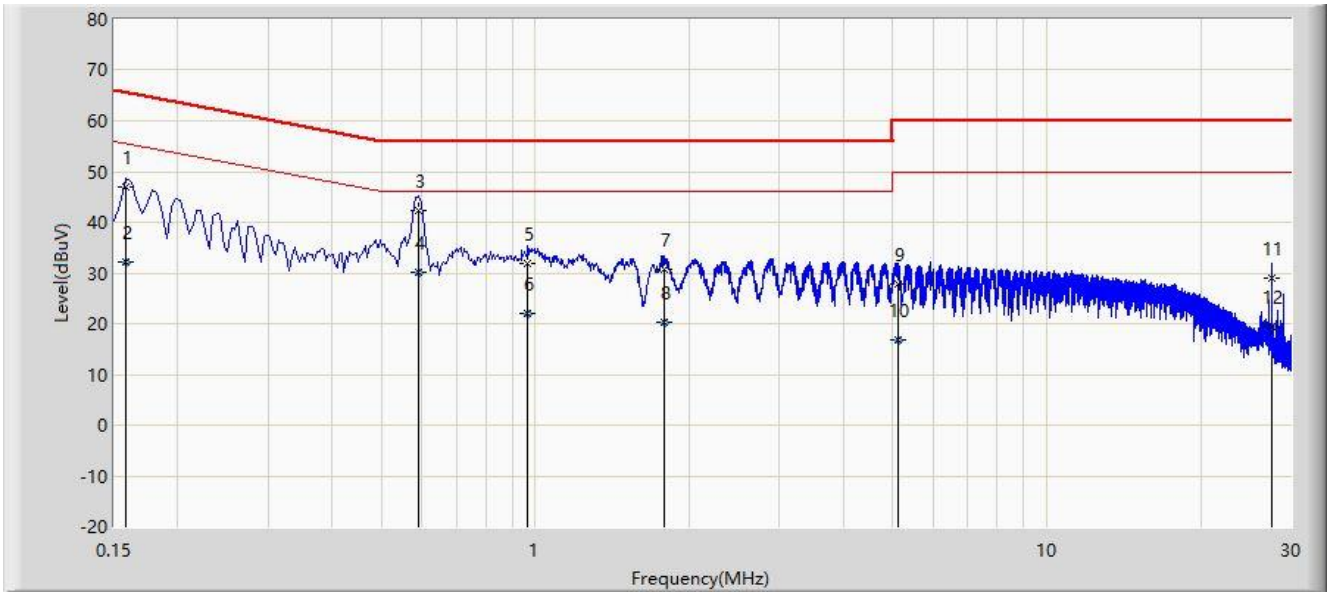

No	Flag	Mark	Frequency (MHz)	Measure Level (dBuV)	Reading Level (dBuV)	Margin (dB)	Limit (dBuV)	Factor (dB)	Type
1			0.158	47.078	36.785	-18.491	65.568	10.293	QP
2			0.158	32.160	21.867	-23.409	55.568	10.293	AV
3		*	0.590	42.372	32.201	-13.628	56.000	10.171	QP
4			0.590	30.097	19.926	-15.903	46.000	10.171	AV
5			0.966	31.845	21.863	-24.155	56.000	9.982	QP
6			0.966	21.913	11.931	-24.087	46.000	9.982	AV
7			1.786	30.584	20.632	-25.416	56.000	9.951	QP
8			1.786	20.181	10.230	-25.819	46.000	9.951	AV
9			5.118	27.847	17.974	-32.153	60.000	9.873	QP
10			5.118	16.713	6.840	-33.287	50.000	9.873	AV
11			27.498	28.940	18.690	-31.060	60.000	10.250	QP
12			27.498	19.384	9.134	-30.616	50.000	10.250	AV

Note: Measure Level (dBuV) = Reading Level (dBuV) + Factor (dB)

Factor (dB) = Cable Loss (dB) + LISN Factor (dB)

7. CONCLUSION

The data collected relate only the item(s) tested and show that the unit is compliance with Part 15C of the FCC rules.

————— The End —————

Appendix A - Test Setup Photograph

Refer to "2004RSU052-UT" file.

Appendix B - EUT Photograph

Refer to "2004RSU052-UE" file.