

MEASUREMENT REPORT

FCC PART 15.247 / Bluetooth-LE

FCC ID: DD4-SBH2240
Applicant: Shure Incorporated
Application Type: Certification
Product: Wireless Headphones
Model No.: SBH2240
Trademark: 
FCC Classification: Digital Transmission System (DTS)
FCC Rule Part(s): Part15 Subpart C (Section 15.247)
Test Procedure(s): ANSI C63.10-2013
Test Date: June 22 ~ 24, 2021

Reviewed By:

Jame Yuan

Jame Yuan

Approved By:

Robin Wu

Robin Wu



The test results relate only to the samples tested.

This equipment has been shown to be capable of compliance with the applicable technical standards as indicated in the measurement report and was tested in accordance with the measurement procedures specified in ANSI C63.10-2013. Test results reported herein relate only to the item(s) tested.

The test report shall not be reproduced except in full without the written approval of MRT Technology (Suzhou) Co., Ltd.

Revision History

Report No.	Version	Description	Issue Date	Note
2106RSU001-U2	Rev. 01	Initial Report	06-25-2021	Valid

CONTENTS

Description	Page
1. General Information.....	5
1.1. Applicant.....	5
1.2. Manufacturer	5
1.3. Testing Facility	5
1.4. Product Information	6
1.5. Radio Specification	6
1.6. Working Frequencies.....	7
1.7. Test Mode	7
1.8. Duty Cycle	8
1.9. EMI Suppression Device(s)/Modifications.....	8
1.10. Test Configuration and Software.....	9
1.11. Test Environment Condition.....	9
2. ANTENNA REQUIREMENTS.....	10
3. TEST EQUIPMENT CALIBRATION DATE	11
4. MEASUREMENT UNCERTAINTY.....	14
5. TEST RESULT	15
5.1. Summary	15
5.2. 6dB Bandwidth Measurement.....	16
5.2.1. Test Limit	16
5.2.2. Test Procedure used.....	16
5.2.3. Test Setting.....	16
5.2.4. Test Setup.....	16
5.2.5. Test Result.....	17
5.3. Output Power Measurement.....	19
5.3.1. Test Limit	19
5.3.2. Test Procedure Used	19
5.3.3. Test Setting.....	19
5.3.4. Test Setup.....	20
5.3.5. Test Result.....	21
5.4. Power Spectral Density Measurement.....	22
5.4.1. Test Limit	22
5.4.2. Test Procedure Used	22
5.4.3. Test Setting.....	22
5.4.4. Test Setup.....	22
5.4.5. Test Result.....	23

5.5.	Conducted Band Edge and Out-of-Band Emissions.....	25
5.5.1.	Test Limit	25
5.5.2.	Test Procedure Used	25
5.5.3.	Test Setting.....	25
5.5.4.	Test Setup.....	26
5.5.5.	Test Result.....	27
5.6.	Radiated Spurious Emission Measurement	31
5.6.1.	Test Limit	31
5.6.2.	Test Procedure Used	31
5.6.3.	Test Setting.....	31
5.6.4.	Test Setup.....	33
5.6.5.	Test Result.....	34
5.7.	Radiated Restricted Band Edge Measurement	42
5.7.1.	Test Limit	42
5.7.2.	Test Procedure Used	43
5.7.3.	Test Setting.....	43
5.7.4.	Test Setup.....	44
5.7.5.	Test Result.....	45
5.8.	AC Conducted Emissions Measurement.....	61
5.8.1.	Test Limit	61
5.8.2.	Test Setup.....	61
5.8.3.	Test Result.....	62
6.	CONCLUSION.....	64
	Appendix A - Test Setup Photograph	65
	Appendix B - EUT Photograph.....	66

1.4. Product Information

Product Name	Wireless Headphones
Model No.	SBH2240
Serial No.	Conducted Sample: 3AC18705275 Radiated Sample: 3AC18705364
Operating Temperature	0 ~ 45 °C
Bluetooth Version	v5.1 dual mode
Antenna Information	Refer to clause 1.5
Power Type	Internal Li-ion Battery Input or AC/DC Adapter Input

Note: The information of EUT was provided by the manufacturer, and the accuracy of the information shall be the responsibility of the manufacturer.

1.5. Radio Specification

Bluetooth Frequency	2402~2480MHz
Channel Number	40
Type of modulation	GFSK
Data Rate	Up to 2Mbps
Antenna Type	Monopole Antenna
Antenna Gain	2.29dBi

Note: For other features of this EUT, test report will be issued separately.

1.6. Working Frequencies

Channel	Frequency	Channel	Frequency	Channel	Frequency
00	2402 MHz	01	2404 MHz	02	2406 MHz
03	2408 MHz	04	2410 MHz	05	2412 MHz
06	2414 MHz	07	2416 MHz	08	2418 MHz
09	2420 MHz	10	2422 MHz	11	2424 MHz
12	2426 MHz	13	2428 MHz	14	2430 MHz
15	2432 MHz	16	2434 MHz	17	2436 MHz
18	2438 MHz	19	2440 MHz	20	2442 MHz
21	2444 MHz	22	2446 MHz	23	2448 MHz
24	2450 MHz	25	2452 MHz	26	2454 MHz
27	2456 MHz	28	2458 MHz	29	2460 MHz
30	2462 MHz	31	2464 MHz	32	2466 MHz
33	2468 MHz	34	2470 MHz	35	2472 MHz
36	2474 MHz	37	2476 MHz	38	2478 MHz
39	2480 MHz	--	--	--	--

1.7. Test Mode

Test Mode	Mode 1: Transmit by BLE-1Mbps
	Mode 2: Transmit by BLE-2Mbps

1.8. Duty Cycle

The maximum achievable duty cycles were determined based on measurements performed on a spectrum analyzer in zero-span mode with RBW = 8MHz, VBW = 50MHz. The RBW and VBW were both greater than 50/T, where T is the minimum transmission duration, and the number of sweep points across T was greater than 100. The duty cycles are as follows:

Test Mode	Duty Cycle
BLE- 1Mbps	85.0%
BLE- 2Mbps	56.9%

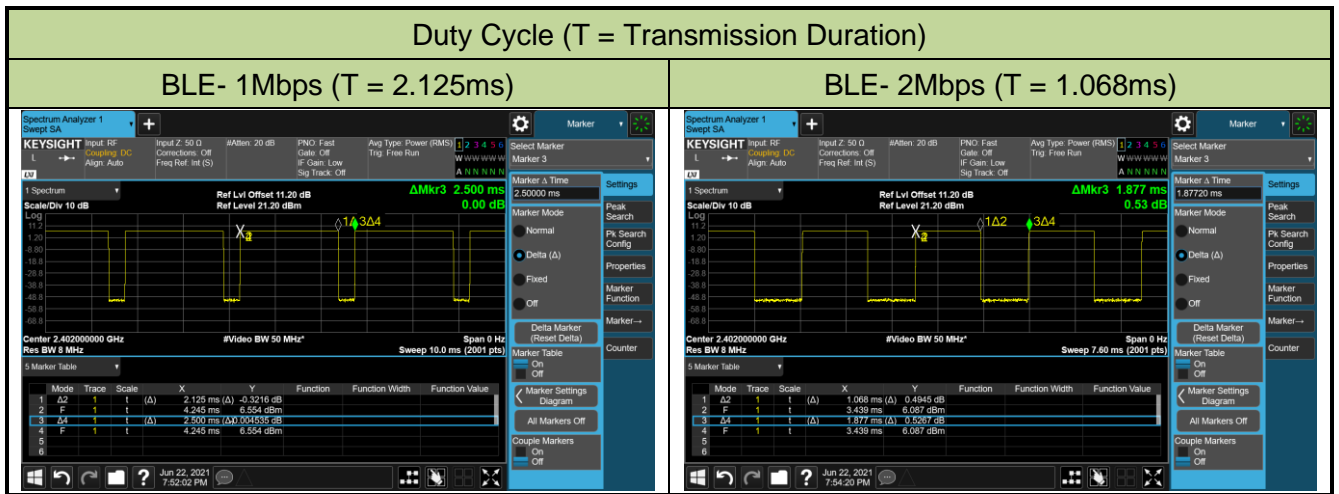

1.9. EMI Suppression Device(s)/Modifications

No EMI suppression device(s) were added and/or no modifications were made during testing.

1.10. Test Configuration and Software

The device was tested per the guidance ANSI C63.10-2013 that was used to reference the appropriate EUT setup for radiated spurious emissions and AC line conducted emission testing.

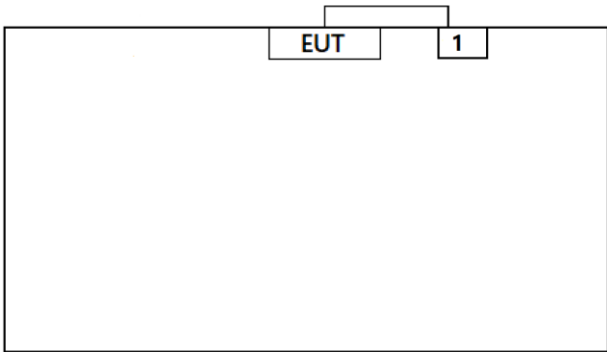
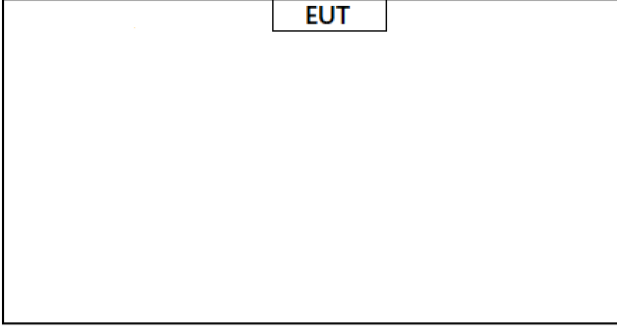
AC line conducted emission		Radiated spurious emissions	
			
Product	Manufacturer	Model No.	
1 Adapter	Shenzhen Honor Electronic Co., Ltd	ADS-12B-06 05010E	

Note 1: The test utility software used during testing was “BlueTest3”, and the version was 3.3.7.

Note 2: Detail power setting refer to operation description.

1.11. Test Environment Condition

Ambient Temperature	15 ~ 35 °C
Relative Humidity	20 ~75 %RH

2. ANTENNA REQUIREMENTS

Excerpt from §15.203 of the FCC Rules/Regulations:

“An intentional radiator antenna shall be designed to ensure that no antenna other than that furnished by the responsible party can be used with the device. The use of a permanently attached antenna or of an antenna that uses a unique coupling to the intentional radiator shall be considered sufficient to comply with the provisions of this section.”

- The antenna of the device is **permanently attached**.
- There are no provisions for connection to an external antenna.

Conclusion:

The unit complies with the requirement of §15.203.

3. TEST EQUIPMENT CALIBRATION DATE

Conducted Emission (WZ-SR2)

Instrument	Manufacturer	Type No.	Asset No.	Cali. Interval	Cali. Due Date
EMI Test Receiver	R&S	ESR3	MRTSUE06909	1 year	2021/11/22
Two-Line V-Network	R&S	ENV216	MRTSUE06002	1 year	2022/06/08
Thermal Hygrometer	testo	608-H1	MRTSUE06404	1 year	2021/07/26
Shielding Room	MIX-BEP	Chamber-SR2	MRTSUE06215	N/A	N/A

Conducted Emission (SIP-SR2)

Instrument	Manufacturer	Type No.	Asset No.	Cali. Interval	Cali. Due Date
EMI Test Receiver	R&S	ESR3	MRTSUE06613	1 year	2021/07/02
Two-Line V-Network	R&S	ENV216	MRTSUE06003	1 year	2022/06/08
Thermal Hygrometer	testo	608-H1	MRTSUE06621	1 year	2021/12/03

Radiated Emission (WZ-AC1)

Instrument	Manufacturer	Type No.	Asset No.	Cali. Interval	Cali. Due Date
EMI Test Receiver	R&S	ESR7	MRTSUE06001	1 year	2022/01/04
Loop Antenna	Schwarzbeck	FMZB 1519	MRTSUE06025	1 year	2021/11/08
Bilog Period Antenna	Schwarzbeck	VULB 9168	MRTSUE06172	1 year	2021/08/08
Horn Antenna	Schwarzbeck	BBHA 9120D	MRTSUE06023	1 year	2021/09/27
Horn Antenna	Schwarzbeck	BBHA9170	MRTSUE06597	1 year	2021/12/14
Microwave System Amplifier	Agilent	83017A	MRTSUE06076	1 year	2021/11/14
Preamplifier	Schwarzbeck	BBV 9721	MRTSUE06121	1 year	2022/06/10
Thermal Hygrometer	testo	608-H1	MRTSUE06403	1 year	2021/07/26
Anechoic Chamber	TDK	Chamber-AC1	MRTSUE06212	1 year	2022/04/29

Radiated Emission (WZ-AC2)

Instrument	Manufacturer	Type No.	Asset No.	Cali. Interval	Cali. Due Date
MXE EMI Receiver	Keysight	N9038A	MRTSUE06125	1 year	2021/07/02
Loop Antenna	Schwarzbeck	FMZB 1519	MRTSUE06025	1 year	2021/11/08
Bilog Period Antenna	Schwarzbeck	VULB 9162	MRTSUE06022	1 year	2022/05/24
Broad-Band Horn Antenna	Schwarzbeck	BBHA 9120D	MRTSUE06171	1 year	2021/10/25
Horn Antenna	Schwarzbeck	BBHA9170	MRTSUE06597	1 year	2021/12/14
Broadband Coaxial Preamplifier	Schwarzbeck	BBV 9718	MRTSUE06176	1 year	2021/11/14
Thermal Hygrometer	Minggao	ETH529	MRTSUE06170	1 year	2021/12/08
Anechoic Chamber	RIKEN	Chamber-AC2	MRTSUE06213	1 year	2022/04/29

Radiated Emission (SIP-AC1)

Instrument	Manufacturer	Type No.	Asset No.	Cali. Interval	Cali. Due Date
EMI Test Receiver	R&S	ESR3	MRTSUE06612	1 year	2021/07/02
EXA Signal Analyzer	Keysight	N9010B	MRTSUE06559	1 year	2021/07/23
Loop Antenna	Schwarzbeck	FMZB 1519 B	MRTSUE06937	1 year	2022/03/09
Bilog Period Antenna	Schwarzbeck	VULB9168	MRTSUE06645	1 year	2021/08/30
Double Ridged Horn Antenna	R&S	HF907	MRTSUE06610	1 year	2021/08/30
Preamplifier	EMCI	EMC051845SE	MRTSUE06600	1 year	2021/11/09
Thermal Hygrometer	testo	608-H1	MRTSUE06620	1 year	2021/12/03
Anechoic Chamber	RIKEN	SIP-AC1	MRTSUE06554	1 year	2021/12/24

Radiated Emission (SIP-AC2)

Instrument	Manufacturer	Type No.	Asset No.	Cali. Interval	Cali. Due Date
EMI Test Receiver	R&S	ESR3	MRTSUE06613	1 year	2021/07/02
MXA Signal Analyzer	Keysight	N9020B	MRTSUE06604	1 year	2021/09/26
Loop Antenna	Schwarzbeck	FMZB 1519 B	MRTSUE06937	1 year	2022/03/09
Bilog Period Antenna	Schwarzbeck	VULB9168	MRTSUE06646	1 year	2021/08/30
Horn Antenna	Schwarzbeck	BBHA9120D	MRTSUE06648	1 year	2021/11/26
Horn Antenna	Schwarzbeck	BBHA9170	MRTSUE06599	1 year	2021/11/26
Preamplifier	EMCI	EMC051845SE	MRTSUE06644	1 year	2021/11/09
Preamplifier	EMCI	EMC184045SE	MRTSUE06602	1 year	2021/10/12
Thermal Hygrometer	testo	608-H1	MRTSUE06624	1 year	2021/12/03
Anechoic Chamber	RIKEN	SIP-AC2	MRTSUE06781	1 year	2021/12/24

Radiated Emission (SIP-AC3)

Instrument	Manufacturer	Type No.	Asset No.	Cali. Interval	Cali. Due Date
Preamplifier	Schwarzbeck	BBV 9721	MRTSUE06121	1 year	2022/06/10
EMI Test Receiver	R&S	ESR3	MRTSUE06612	1 year	2021/07/02
EXA Signal Analyzer	Keysight	N9010B	MRTSUE06559	1 year	2021/07/23
Loop Antenna	Schwarzbeck	FMZB 1519	MRTSUE06025	1 year	2021/11/08
Bilog Period Antenna	Schwarzbeck	VULB9168	MRTSUE06646	1 year	2021/08/30
Double Ridged Horn Antenna	R&S	HF907	MRTSUE06611	1 year	2021/09/13
Horn Antenna	Schwarzbeck	BBHA9170	MRTSUE06598	1 year	2021/11/26
Preamplifier	EMCI	EMC012645SE	MRTSUE06642	1 year	2022/01/14
Thermal Hygrometer	testo	608-H1	MRTSUE06622	1 year	2021/12/03
Anechoic Chamber	RIKEN	SIP-AC3	MRTSUE06782	1 year	2021/12/24

Conducted Test Equipment (WZ-SR5)

Instrument	Manufacturer	Type No.	Asset No.	Cali. Interval	Cali. Due Date
EXA Signal Analyzer	Agilent	N9020A	MRTSUE06106	1 year	2022/04/13
EXA Signal Analyzer	Keysight	N9010B	MRTSUE06607	1 year	2022/01/06
Power Meter	Agilent	U2021XA	MRTSUE06030	1 year	2021/10/22
USB wideband power sensor	Keysight	U2021XA	MRTSUE06446	1 year	2022/06/08
USB wideband power sensor	Keysight	U2021XA	MRTSUE06447	1 year	2022/06/08
Bluetooth Test Set	Anritsu	MT8852B-042	MRTSUE06389	1 year	2022/06/08
Modulation Analyzer	HP	HP8901A	MRTSUE06098	1 year	2021/09/26
DC Power Supply	GWINSTEK	DPS-3303C	MRTSUE06064	N/A	N/A
Temperature & Humidity Chamber	BAOYT	BYH-150CL	MRTSUE06051	1 year	2021/10/22
Thermal Hygrometer	testo	608-H1	MRTSUE06401	1 year	2021/07/26

Conducted Test Equipment (SIP-TR1)

Instrument	Manufacturer	Type No.	Asset No.	Cali. Interval	Cali. Due Date
EXA Signal Analyzer	KEYSIGHT	N9010B	MRTSUE06603	1 year	2021/11/23
PXA Signal Analyzer	Keysight	N9030B	MRTSUE06395	1 year	2021/08/30
USB wideband power sensor	Agilent	U2021XA	MRTSUE06595	1 year	2021/09/26
USB wideband power sensor	Agilent	U2021XA	MRTSUE06596	1 year	2021/09/26
Temperature Chamber	BAOYT	BYG-408CS	MRTSUE06847	1 year	2022/02/23
Thermal Hygrometer	testo	608-H1	MRTSUE11022	1 year	2021/11/25

Software	Version	Function
EMI Software	V3	EMI Test Software

4. MEASUREMENT UNCERTAINTY

Where relevant, the following test uncertainty levels have been estimated for tests performed on the EUT as specified in CISPR 16-4-2. This uncertainty represents an expanded uncertainty expressed at approximately the 95% confidence level using a coverage factor of $k = 2$.

AC Conducted Emission Measurement
Measurement Uncertainty for a Level of Confidence of 95% ($U=2Uc(y)$): 9kHz~150kHz: 3.74dB 150kHz~30MHz: 3.44dB
Radiated Disturbance
Measurement Uncertainty for a Level of Confidence of 95% ($U=2Uc(y)$): Horizontal: 9kHz~300MHz: 5.04dB 300MHz~1GHz: 4.95dB 1GHz~40GHz: 6.40dB Vertical: 9kHz~300MHz: 5.24dB 300MHz~1GHz: 6.03dB 1GHz~40GHz: 6.40dB
Spurious Emissions, Conducted
Measuring Uncertainty for a Level of Confidence of 95% ($U=2Uc(y)$): 0.78dB
Output Power
Measuring Uncertainty for a Level of Confidence of 95% ($U=2Uc(y)$): 1.13dB
Power Spectrum Density
Measuring Uncertainty for a Level of Confidence of 95% ($U=2Uc(y)$): 1.15dB
Occupied Bandwidth
Measuring Uncertainty for a Level of Confidence of 95% ($U=2Uc(y)$): 0.28%

5. TEST RESULT

5.1. Summary

FCC Part Section(s)	Test Description	Test Limit	Test Condition	Test Result	Reference
15.247(a)(2)	6dB Bandwidth	$\geq 500\text{kHz}$	Conducted	Pass	Section 5.2
15.247(b)(3)	Output Power	$\leq 1\text{Watt}$		Pass	Section 5.3
15.247(e)	Power Spectral Density	$\leq 8\text{dBm} / 3\text{kHz}$		Pass	Section 5.4
15.247(d)	Band Edge / Out-of-Band Emissions	$\geq 20\text{dBc (Peak)}$		Pass	Section 5.5
15.205 15.209	General Field Strength (Restricted Bands and Radiated Emission)	Emissions in restricted bands must meet the radiated limits detailed in 15.209	Radiated	Pass	Section 5.6 Section 5.7
15.207	AC Conducted Emissions 150kHz - 30MHz	< FCC 15.207 limits >	Line Conducted	Pass	Section 5.8

Notes:

- 1) The analyzer plots shown in this section were all taken with a correction table loaded into the analyzer. The correction table was used to account for the losses of the cables and attenuators used as part of the system to connect the EUT to the analyzer at all frequencies of interest.
- 2) All modes of operation and data rates were investigated. For radiated emission test, every axis (X, Y, Z) was also verified. The test results shown in the following sections represent the worst case emissions.

5.2. 6dB Bandwidth Measurement

5.2.1. Test Limit

The minimum 6dB bandwidth shall be at least 500 kHz.

5.2.2. Test Procedure used

ANSI C63.10-2013 - Section 11.8

5.2.3. Test Setting

1. The Spectrum's automatic bandwidth measurement capability was used to perform the 6dB bandwidth measurement. The "X" dB bandwidth parameter was set to $X = 6$. The bandwidth measurement was not influenced by any intermediate power nulls in the fundamental emission.
2. Set RBW = 100 kHz
3. VBW $\geq 3 \times$ RBW
4. Detector = Peak
5. Trace mode = Max hold
6. Sweep = Auto couple
7. Allow the trace was allowed to stabilize

5.2.4. Test Setup

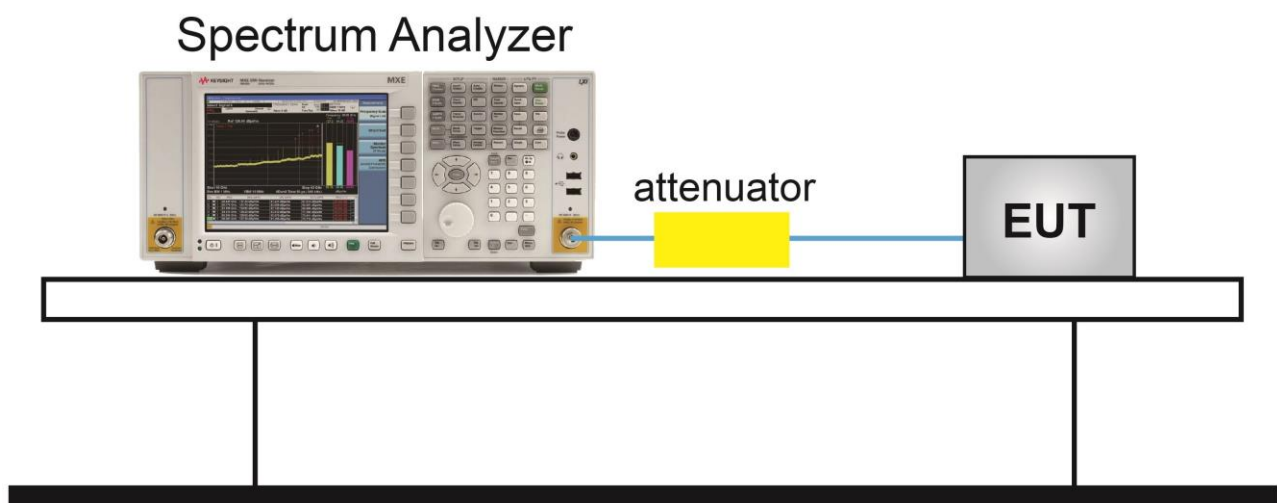

5.2.5. Test Result

Test Site	WZ-SR5	Test Engineer	Bella Chen
Test Date	2021/06/22		

Test Mode	Data Rate (Mbps)	Channel No.	Frequency (MHz)	6dB Bandwidth (MHz)	Limit (MHz)	Result
BLE	1	00	2402	0.7076	≥ 0.5	Pass
BLE	1	19	2440	0.7037	≥ 0.5	Pass
BLE	1	39	2480	0.7039	≥ 0.5	Pass
BLE	2	00	2402	1.2710	≥ 0.5	Pass
BLE	2	19	2440	1.2780	≥ 0.5	Pass
BLE	2	39	2480	1.2670	≥ 0.5	Pass

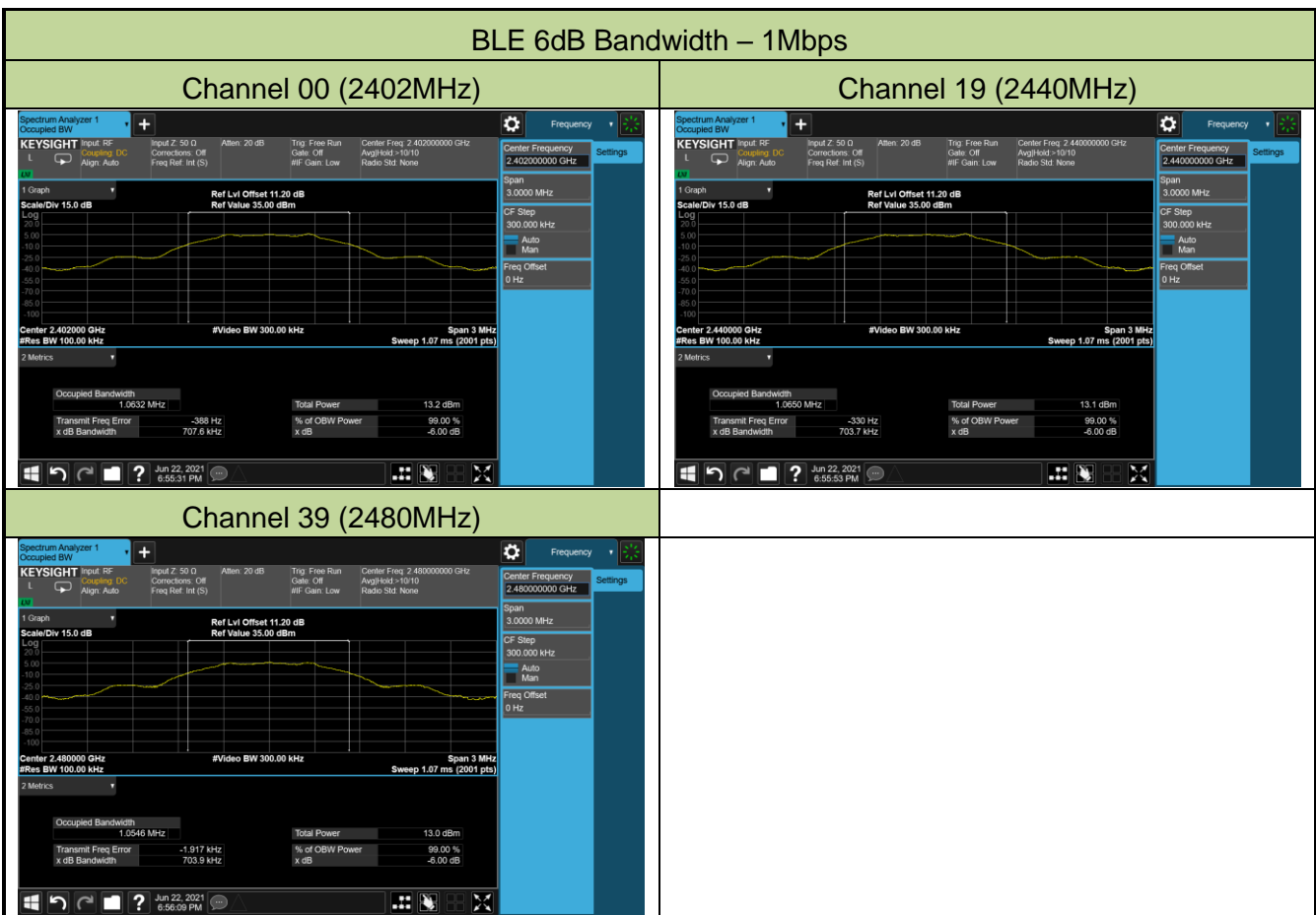

BLE 6dB Bandwidth – 2Mbps

Channel 00 (2402MHz)



Channel 19 (2440MHz)



Channel 39 (2480MHz)



5.3. Output Power Measurement

5.3.1. Test Limit

The maximum output power shall be less 1 Watt (30dBm).

5.3.2. Test Procedure Used

ANSI C63.10-2013 - Section 11.9.1.3

ANSI C63.10-2013 - Section 11.9.2.3.2

5.3.3. Test Setting

Method PKPM1 (Peak Power Measurement)

Peak power measurements were performed only when the EUT was transmitting at its maximum power control level using a broadband power meter with a pulse sensor. The pulse sensor employs a VBW = 50MHz so this method was only used for signals whose DTS bandwidth was less than or equal to 50MHz.

Method AVGPM-G (Measurement using a gated RF average-reading power meter)

Measurements may be performed using a wideband gated RF power meter provided that the gate parameters are adjusted such that the power is measured only when the EUT is transmitting at its maximum power control level. Since this measurement is made only during the ON time of the transmitter, no duty cycle correction is required.

5.3.4. Test Setup

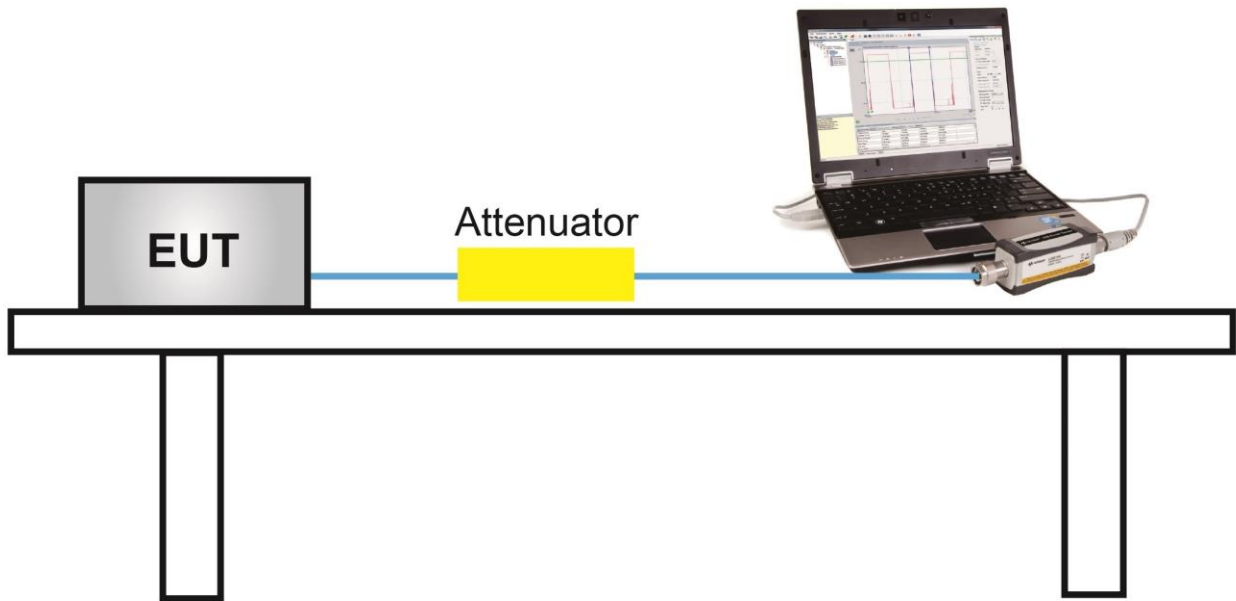

5.3.5. Test Result

Test Site	WZ-SR5	Test Engineer	Bella Chen
Test Date	2021/06/22		

Test Result of Peak Output Power

Test Mode	Data Rate (Mbps)	Channel No.	Frequency (MHz)	Peak Power (dBm)	Limit (dBm)	Result
BLE	1	00	2402	6.82	≤ 30.00	Pass
BLE	1	19	2440	6.87	≤ 30.00	Pass
BLE	1	39	2480	6.85	≤ 30.00	Pass
BLE	2	00	2402	6.84	≤ 30.00	Pass
BLE	2	19	2440	6.92	≤ 30.00	Pass
BLE	2	39	2480	6.85	≤ 30.00	Pass

Test Result of Average Output Power (Reporting Only)

Test Mode	Data Rate (Mbps)	Channel No.	Frequency (MHz)	Average Power (dBm)	Limit (dBm)	Result
BLE	1	00	2402	6.60	≤ 30.00	Pass
BLE	1	19	2440	6.58	≤ 30.00	Pass
BLE	1	39	2480	6.60	≤ 30.00	Pass
BLE	2	00	2402	6.70	≤ 30.00	Pass
BLE	2	19	2440	6.77	≤ 30.00	Pass
BLE	2	39	2480	6.80	≤ 30.00	Pass

5.4. Power Spectral Density Measurement

5.4.1. Test Limit

The maximum permissible power spectral density is 8dBm in any 3 kHz band.

The same method of determining the conducted output power shall be used to determine the power spectral density.

5.4.2. Test Procedure Used

ANSI C63.10-2013 - Section 11.10.2

5.4.3. Test Setting

1. Analyzer was set to the center frequency of the DTS channel under investigation
2. Span = 1.5 times the OBW
3. RBW = 3kHz
4. VBW = 10kHz
5. Detector = Peak
6. Sweep time = Auto couple
7. Trace mode = Max hold
8. Trace was allowed to stabilize

5.4.4. Test Setup

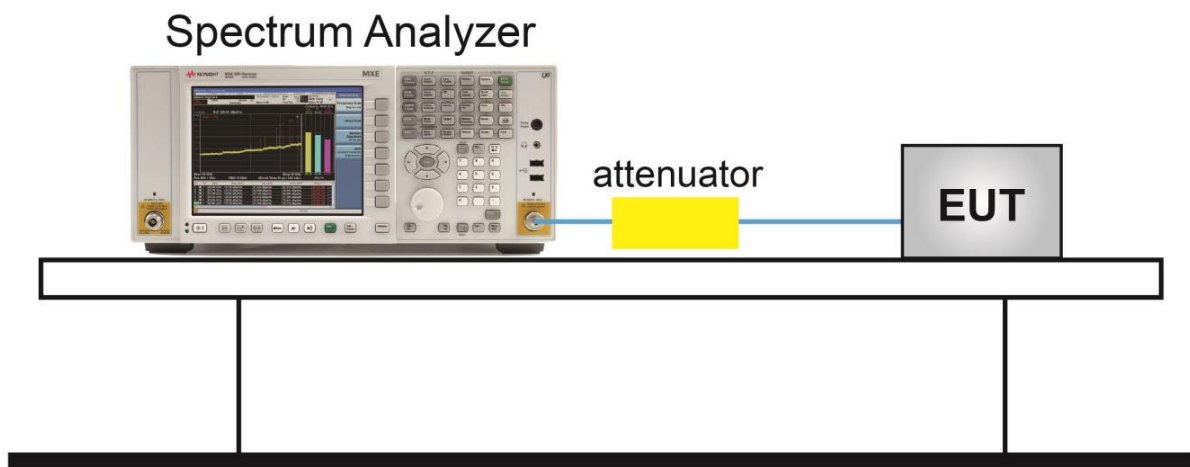

5.4.5. Test Result

Test Site	WZ-SR5	Test Engineer	Bella Chen
Test Date	2021/06/22		

Test Mode	Data Rate (Mbps)	Channel No.	Frequency (MHz)	PSD Result (dBm / 3kHz)	Limit (dBm / 3kHz)	Result
BLE	1	00	2402	-9.09	≤ 8.00	Pass
BLE	1	19	2440	-9.22	≤ 8.00	Pass
BLE	1	39	2480	-9.20	≤ 8.00	Pass
BLE	2	00	2402	-10.51	≤ 8.00	Pass
BLE	2	19	2440	-10.21	≤ 8.00	Pass
BLE	2	39	2480	-10.22	≤ 8.00	Pass

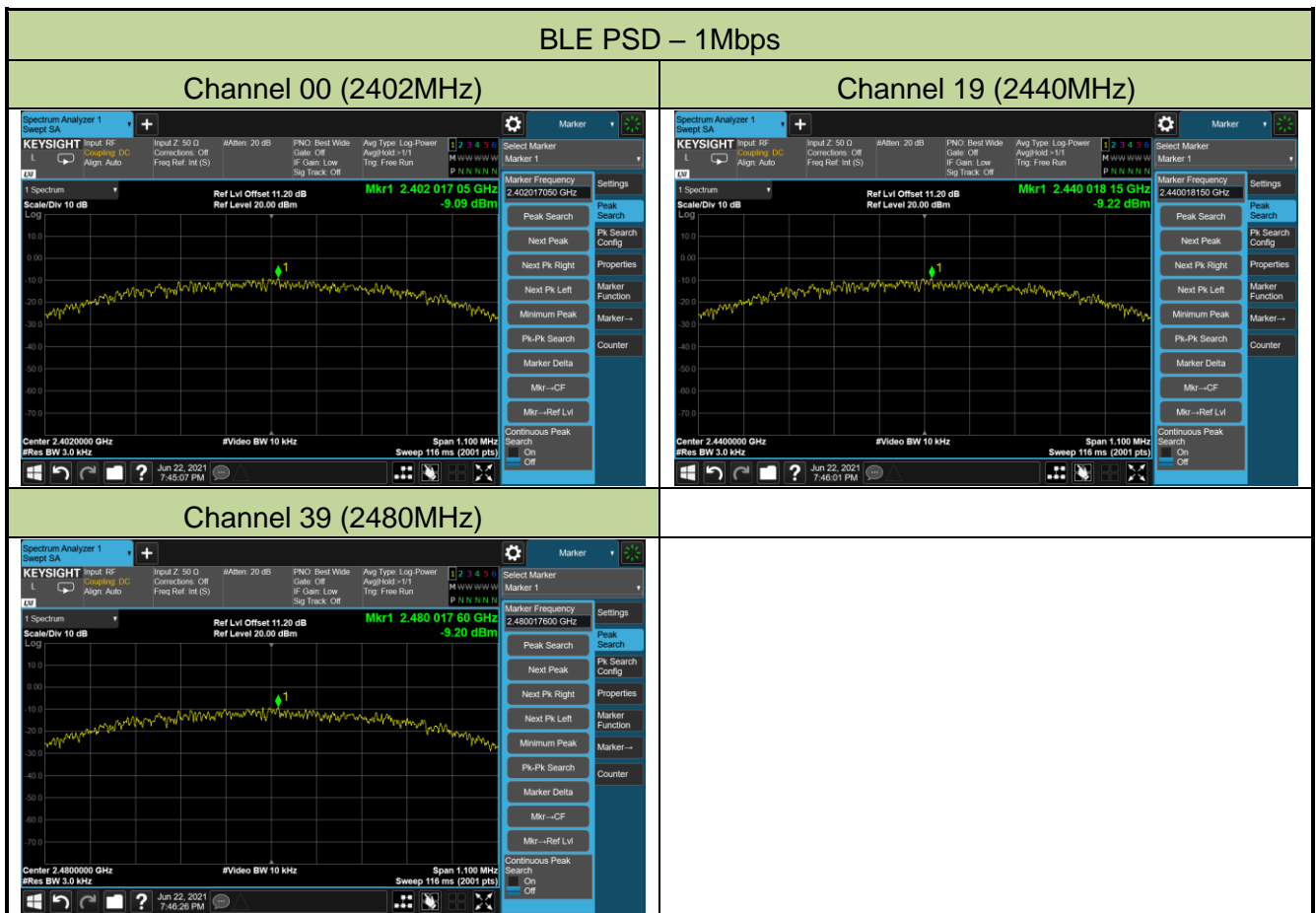

BLE PSD – 2Mbps

Channel 00 (2402MHz)

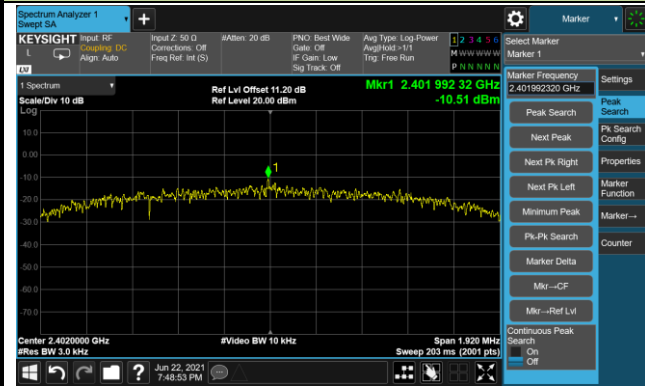

Channel 19 (2440MHz)

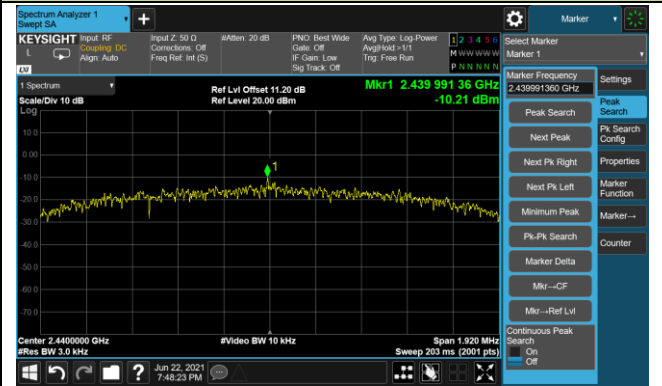

Channel 39 (2480MHz)



5.5. Conducted Band Edge and Out-of-Band Emissions

5.5.1. Test Limit

The limit for out-of-band spurious emissions at the band edge is 20dB below the fundamental emission level, as determined from the in-band power measurement of the DTS channel performed in a 100kHz bandwidth per the PSD procedure.

5.5.2. Test Procedure Used

ANSI C63.10-2013 - Section 11.11

5.5.3. Test Setting

Reference level measurement

1. Set instrument center frequency to DTS channel center frequency
2. Set the span to ≥ 1.5 times the DTS bandwidth
3. Set the RBW = 100 kHz
4. Set the VBW $\geq 3 \times$ RBW
5. Detector = Peak
6. Sweep time = Auto couple
7. Trace mode = Max hold
8. Allow trace to fully stabilize

Emission level measurement

1. Set the center frequency and span to encompass frequency range to be measured
2. RBW = 100kHz
3. VBW = 300kHz
4. Detector = Peak
5. Trace mode = Max hold
6. Sweep time = Auto couple
7. The trace was allowed to stabilize

5.5.4. Test Setup

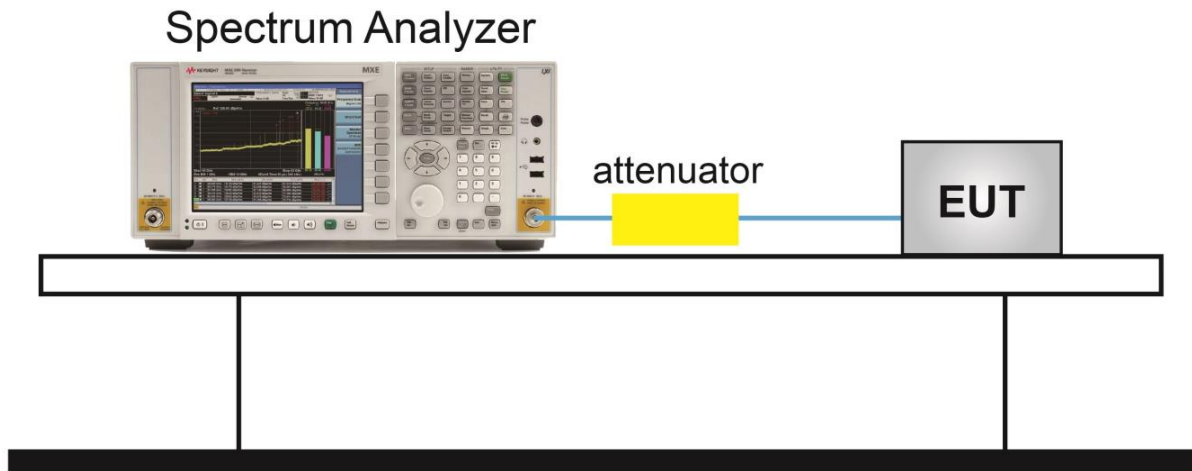

5.5.5. Test Result

Test Site	WZ-SR5	Test Engineer	Bella Chen
Test Date	2021/06/22		

Test Mode	Data Rate (Mbps)	Channel No.	Frequency (MHz)	Limit	Result
BLE	1	00	2402	20dBc	Pass
BLE	1	19	2440	20dBc	Pass
BLE	1	39	2480	20dBc	Pass
BLE	2	00	2402	20dBc	Pass
BLE	2	19	2440	20dBc	Pass
BLE	2	39	2480	20dBc	Pass

BLE Out-of-Band Emissions – 1Mbps

Channel 00 (2402MHz)

100kHz PSD reference Level

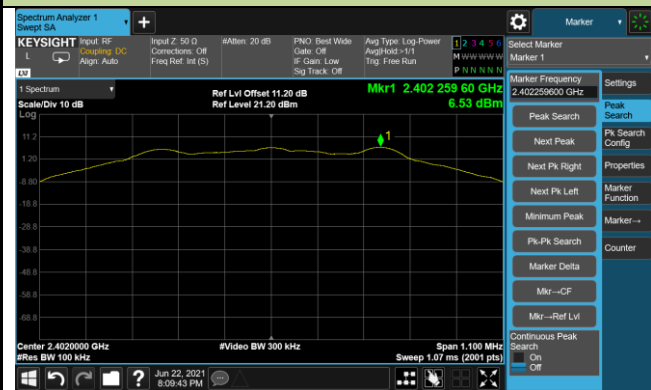

Low Band Edge



Spurious Emission 30MHz ~ 25GHz

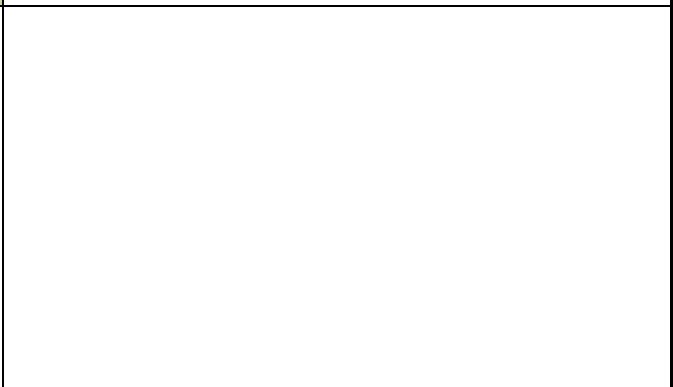
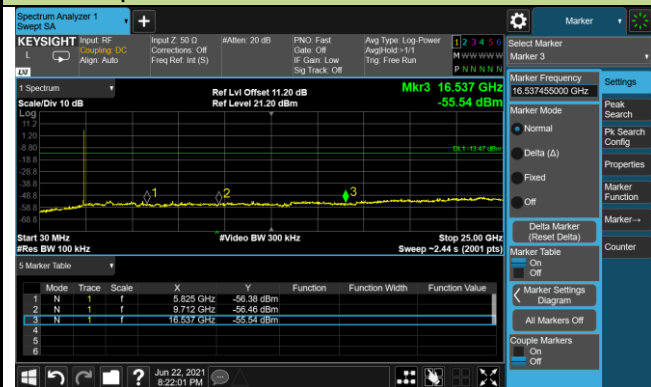

Channel 19 (2440MHz)

100kHz PSD reference Level

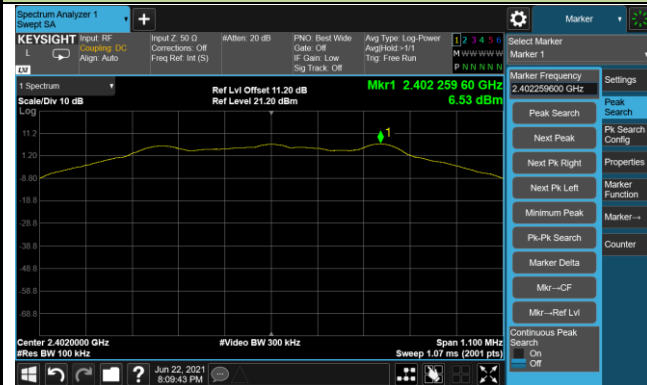

Spurious Emission 30MHz ~ 25GHz

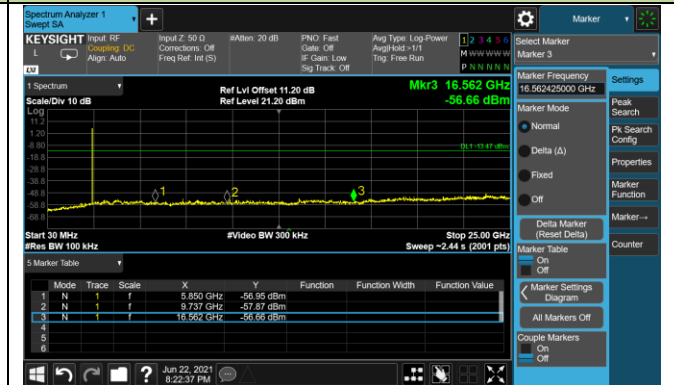

Channel 39 (2480MHz)

100kHz PSD reference Level

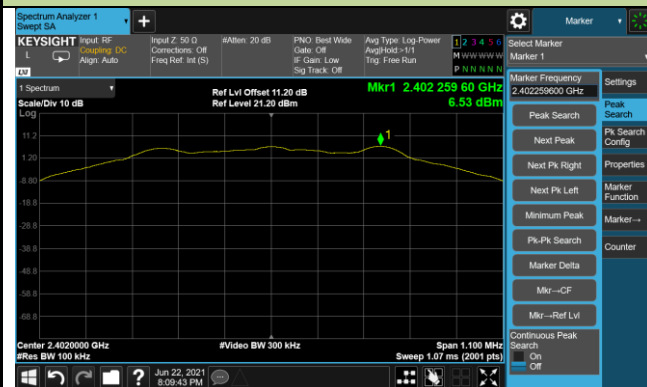

High Band Edge



Spurious Emission 30MHz ~ 25GHz

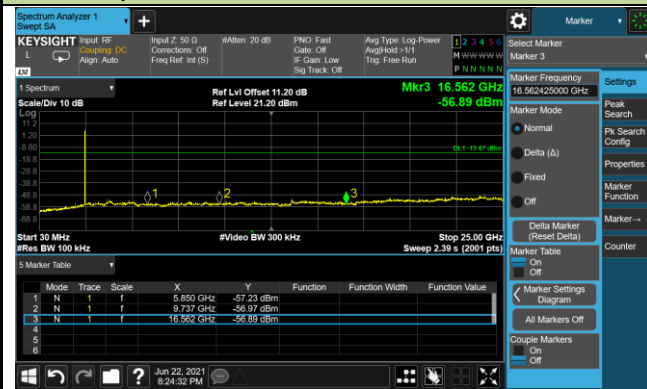

BLE Out-of-Band Emissions – 2Mbps

Channel 00 (2402MHz)

100kHz PSD reference Level

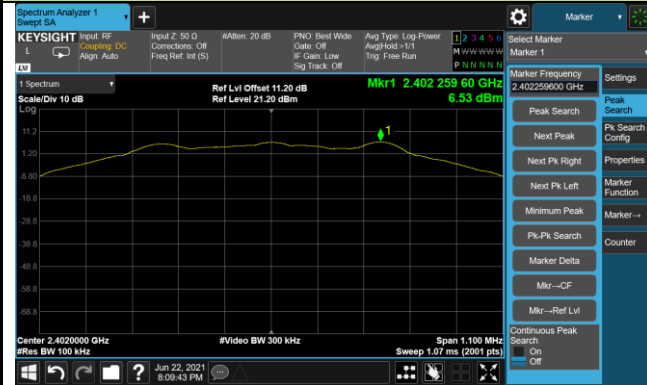

Low Band Edge

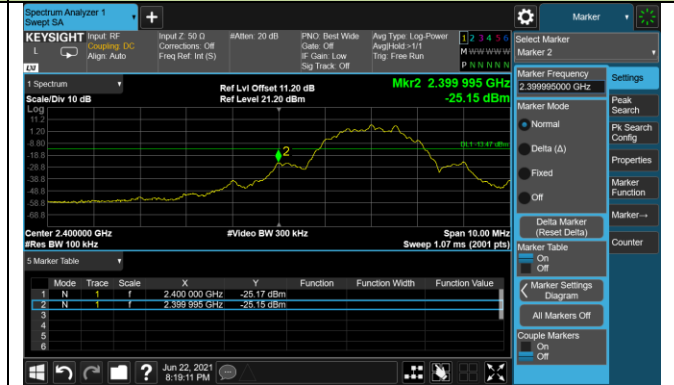

Spurious Emission 30MHz ~ 25GHz

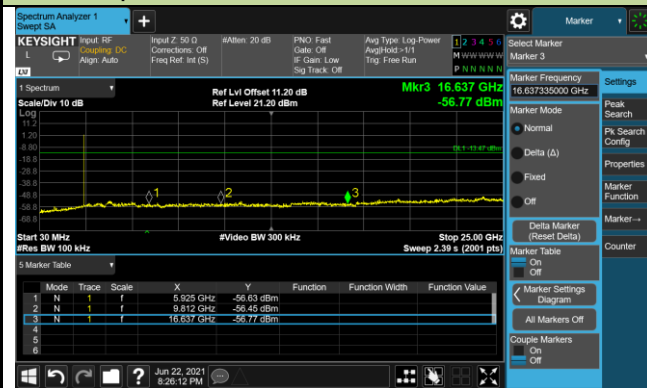

Channel 19 (2440MHz)

100kHz PSD reference Level

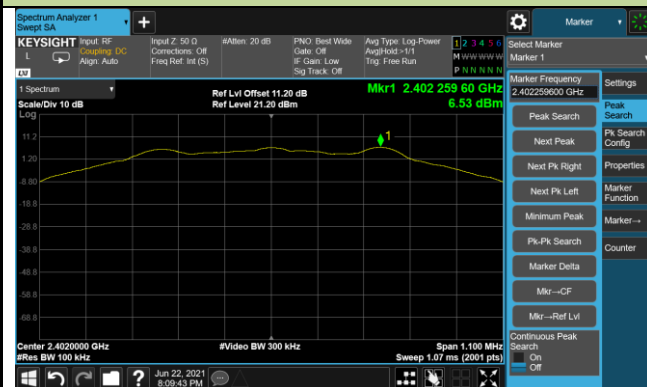

Spurious Emission 30MHz ~ 25GHz

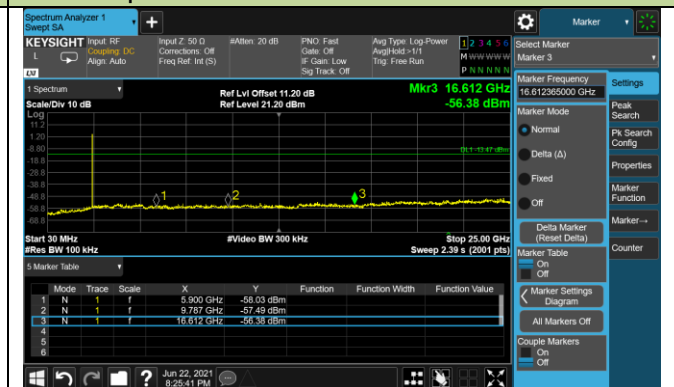

Channel 39 (2480MHz)

100kHz PSD reference Level

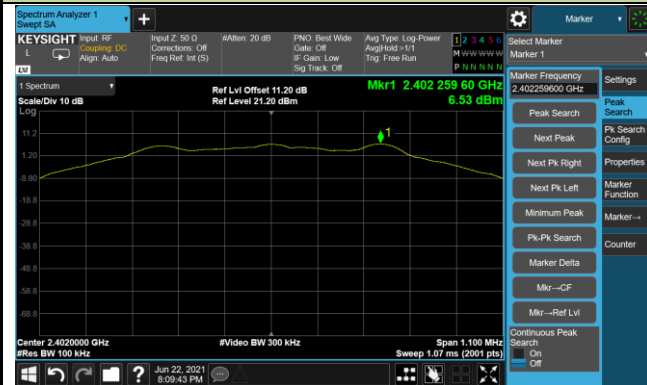

High Band Edge



Spurious Emission 30MHz ~ 25GHz

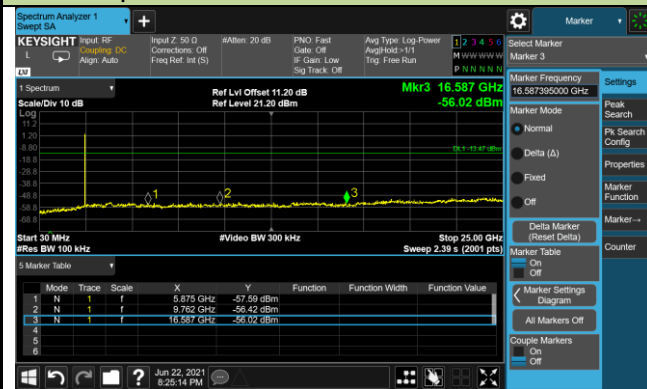

5.6. Radiated Spurious Emission Measurement

5.6.1. Test Limit

All out of band emissions appearing in a restricted band as specified in Section 15.205 of the Title 47 CFR must not exceed the limits shown in Table per Section 15.209.

FCC Part 15 Subpart C Paragraph 15.209		
Frequency (MHz)	Field Strength ($\mu\text{V}/\text{m}$)	Measured Distance (m)
0.009 - 0.490	2400/F (kHz)	300
0.490 - 1.705	24000/F (kHz)	30
1.705 - 30	30	30
30 - 88	100	3
88 - 216	150	3
216 - 960	200	3
Above 960	500	3

5.6.2. Test Procedure Used

ANSI C63.10-2013 - Section 6.3 & 6.4 & 6.5 & 6.6

5.6.3. Test Setting

Table 1 - RBW as a function of frequency

Frequency	RBW
9 ~ 150 kHz	200 ~ 300 Hz
0.15 ~ 30 MHz	9 ~ 10 kHz
30 ~ 1000 MHz	100 ~ 120 kHz
> 1000 MHz	1 MHz

Quasi-Peak Measurements below 1GHz

1. Analyzer center frequency was set to the frequency of the radiated spurious emission of interest
2. Span was set greater than 1MHz
3. RBW = as specified in Table 1
4. Detector = CISPR quasi-peak
5. Sweep time = auto couple
6. Trace was allowed to stabilize

Peak Measurements above 1GHz

1. Analyzer center frequency was set to the frequency of the radiated spurious emission of interest
2. RBW = 1MHz
3. VBW = 3MHz
4. Detector = peak
5. Sweep time = auto couple
6. Trace mode = max hold
7. Trace was allowed to stabilize

Average Measurements above 1GHz (Method VB)

1. Analyzer center frequency was set to the frequency of the radiated spurious emission of interest
2. RBW = 1MHz
3. VBW; If the EUT is configured to transmit with duty cycle $\geq 98\%$, set VBW = 10Hz
If the EUT duty cycle is $< 98\%$, set VBW $\geq 1/T$. T is the minimum transmission duration
4. Detector = Peak
5. Sweep time = auto
6. Trace mode = max hold
7. Trace was allowed to stabilize

5.6.4. Test Setup

Below 1GHz Test Setup:

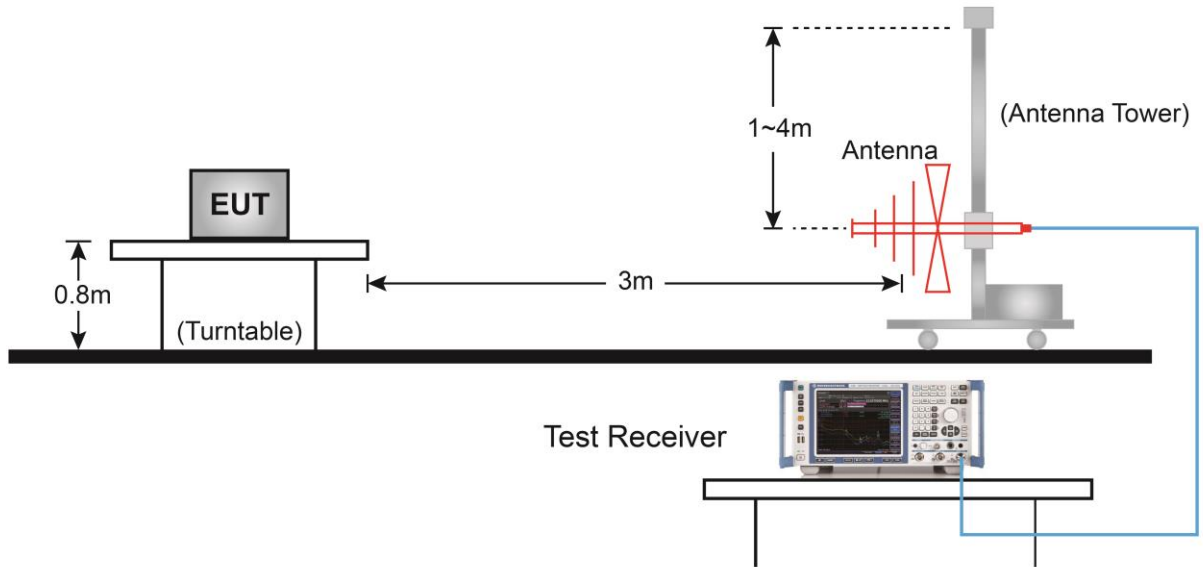

Above 1GHz Test Setup:

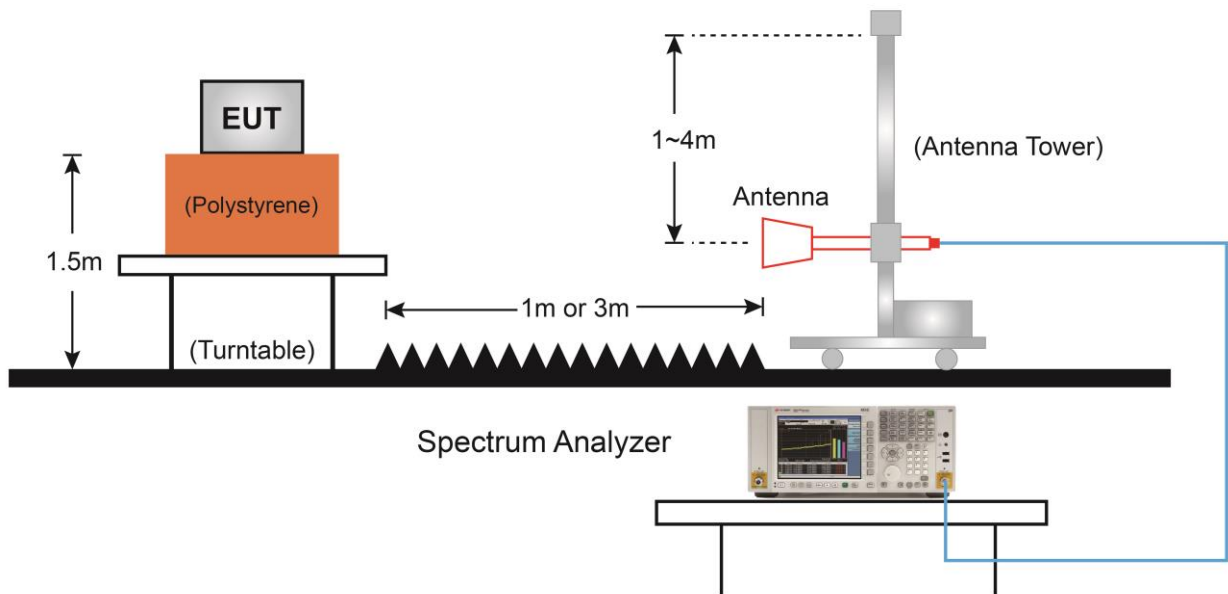

5.6.5. Test Result

Test Site	WZ-AC1	Test Engineer	Tommy Tang
Test Mode	BLE - 1Mbps	Test Date	2021/06/22
Test Channel	00		
Remark	1. Average measurement was not performed if peak level lower than average limit. 2. Other frequency was 20dB below limit line within 1-18GHz, there is not show in the report.		

Frequency (MHz)	Reading Level (dB μ V)	Factor (dB)	Measure Level (dB μ V/m)	Limit (dB μ V/m)	Margin (dB)	Detector	Polarization
4918.5	38.1	3.6	41.7	74.0	-32.3	Peak	Horizontal
7468.5	38.2	8.5	46.7	74.0	-27.3	Peak	Horizontal
8395.0	38.1	8.9	47.0	74.0	-27.0	Peak	Horizontal
4884.5	38.4	3.4	41.8	74.0	-32.2	Peak	Vertical
7604.5	38.4	8.4	46.8	74.0	-27.2	Peak	Vertical
8199.5	38.0	9.1	47.1	74.0	-26.9	Peak	Vertical

Note: Measure Level (dB μ V/m) = Reading Level (dB μ V) + Factor (dB)

Factor (dB) = Cable Loss (dB) + Antenna Factor (dB/m) - Pre_Amplifier Gain (dB)

Test Site	WZ-AC1	Test Engineer	Tommy Tang
Test Mode	BLE - 1Mbps	Test Date	2021/06/22
Test Channel	19		
Remark	1. Average measurement was not performed if peak level lower than average limit. 2. Other frequency was 20dB below limit line within 1-18GHz, there is not show in the report.		

Frequency (MHz)	Reading Level (dB μ V)	Factor (dB)	Measure Level (dB μ V/m)	Limit (dB μ V/m)	Margin (dB)	Detector	Polarization
4884.5	38.1	3.4	41.5	74.0	-32.5	Peak	Horizontal
7315.5	40.0	8.6	48.6	74.0	-25.4	Peak	Horizontal
8191.0	37.5	9.0	46.5	74.0	-27.5	Peak	Horizontal
5122.5	37.5	4.2	41.7	74.0	-32.3	Peak	Vertical
7315.5	45.6	8.6	54.2	74.0	-19.8	Peak	Vertical
7315.5	39.2	8.6	47.8	54.0	-6.2	Average	Vertical
8454.5	37.5	9.3	46.8	74.0	-27.2	Peak	Vertical

Note: Measure Level (dB μ V/m) = Reading Level (dB μ V) + Factor (dB)

Factor (dB) = Cable Loss (dB) + Antenna Factor (dB/m) - Pre_Amplifier Gain (dB)

Test Site	WZ-AC1	Test Engineer	Tommy Tang
Test Mode	BLE - 1Mbps	Test Date	2021/06/22
Test Channel	39		
Remark	1. Average measurement was not performed if peak level lower than average limit. 2. Other frequency was 20dB below limit line within 1-18GHz, there is not show in the report.		

Frequency (MHz)	Reading Level (dB μ V)	Factor (dB)	Measure Level (dB μ V/m)	Limit (dB μ V/m)	Margin (dB)	Detector	Polarization
5071.5	38.3	4.1	42.4	74.0	-31.6	Peak	Horizontal
7443.0	43.5	8.5	52.0	74.0	-22.0	Peak	Horizontal
8174.0	38.4	9.0	47.4	74.0	-26.6	Peak	Horizontal
5003.5	37.6	3.8	41.4	74.0	-32.6	Peak	Vertical
7443.0	46.0	8.5	54.5	74.0	-19.5	Peak	Vertical
7443.0	39.7	8.5	48.2	54.0	-5.8	Average	Vertical
8157.0	39.1	9.1	48.2	74.0	-25.8	Peak	Vertical

Note: Measure Level (dB μ V/m) = Reading Level (dB μ V) + Factor (dB)

Factor (dB) = Cable Loss (dB) + Antenna Factor (dB/m) - Pre_Amplifier Gain (dB)

Test Site	WZ-AC1	Test Engineer	Tommy Tang
Test Mode	BLE - 2Mbps	Test Date	2021/06/22
Test Channel	00		
Remark	1. Average measurement was not performed if peak level lower than average limit. 2. Other frequency was 20dB below limit line within 1-18GHz, there is not show in the report.		

Frequency (MHz)	Reading Level (dB μ V)	Factor (dB)	Measure Level (dB μ V/m)	Limit (dB μ V/m)	Margin (dB)	Detector	Polarization
4935.5	38.7	3.6	42.3	74.0	-31.7	Peak	Horizontal
7400.5	38.7	8.7	47.4	74.0	-26.6	Peak	Horizontal
8131.5	39.2	9.2	48.4	74.0	-25.6	Peak	Horizontal
4774.0	38.6	3.5	42.1	74.0	-31.9	Peak	Vertical
7494.0	38.4	8.7	47.1	74.0	-26.9	Peak	Vertical
8361.0	39.1	9.0	48.1	74.0	-25.9	Peak	Vertical

Note: Measure Level (dB μ V/m) = Reading Level (dB μ V) + Factor (dB)

Factor (dB) = Cable Loss (dB) + Antenna Factor (dB/m) - Pre_Amplifier Gain (dB)

Test Site	WZ-AC1	Test Engineer	Tommy Tang
Test Mode	BLE - 2Mbps	Test Date	2021/06/22
Test Channel	19		
Remark	1. Average measurement was not performed if peak level lower than average limit. 2. Other frequency was 20dB below limit line within 1-18GHz, there is not show in the report.		

Frequency (MHz)	Reading Level (dB μ V)	Factor (dB)	Measure Level (dB μ V/m)	Limit (dB μ V/m)	Margin (dB)	Detector	Polarization
5012.0	37.1	4.0	41.1	74.0	-32.9	Peak	Horizontal
7324.0	40.9	8.6	49.5	74.0	-24.5	Peak	Horizontal
8089.0	36.9	9.2	46.1	74.0	-27.9	Peak	Horizontal
4910.0	38.0	3.5	41.5	74.0	-32.5	Peak	Vertical
7315.5	44.8	8.6	53.4	74.0	-20.6	Peak	Vertical
7315.5	39.1	8.6	47.7	54.0	-6.3	Average	Vertical
8437.5	38.2	9.1	47.3	74.0	-26.7	Peak	Vertical

Note: Measure Level (dB μ V/m) = Reading Level (dB μ V) + Factor (dB)

Factor (dB) = Cable Loss (dB) + Antenna Factor (dB/m) - Pre_Amplifier Gain (dB)

Test Site	WZ-AC1	Test Engineer	Tommy Tang
Test Mode	BLE - 2Mbps	Test Date	2021/06/22
Test Channel	39		
Remark	1. Average measurement was not performed if peak level lower than average limit. 2. Other frequency was 20dB below limit line within 1-18GHz, there is not show in the report.		

Frequency (MHz)	Reading Level (dBμV)	Factor (dB)	Measure Level (dBμV/m)	Limit (dBμV/m)	Margin (dB)	Detector	Polarization
4816.5	38.8	3.5	42.3	74.0	-31.7	Peak	Horizontal
7443.0	43.8	8.5	52.3	74.0	-21.7	Peak	Horizontal
8301.5	38.1	8.9	47.0	74.0	-27.0	Peak	Horizontal
4731.5	39.2	3.2	42.4	74.0	-31.6	Peak	Vertical
7434.5	45.6	8.6	54.2	74.0	-19.8	Peak	Vertical
7434.5	37.5	8.6	46.1	54.0	-7.9	Average	Vertical
8165.5	39.0	9.1	48.1	74.0	-25.9	Peak	Vertical

Note: Measure Level (dBμV/m) = Reading Level (dBμV) + Factor (dB)

Factor (dB) = Cable Loss (dB) + Antenna Factor (dB/m) - Pre_Amplifier Gain (dB)

The Result of Radiated Emission below 1GHz:

Site: WZ-AC1	Time: 2021/06/23
Limit: FCC_Part15.209_RSE(3m)	Engineer: Tommy Tang
Probe: WZ-AC1_VULB 9168 _30-1000MHz	Polarity: Horizontal
EUT: Wireless Headphones	Power: By Battery
Test Mode: Transmit by BLE at channel 2480MHz	

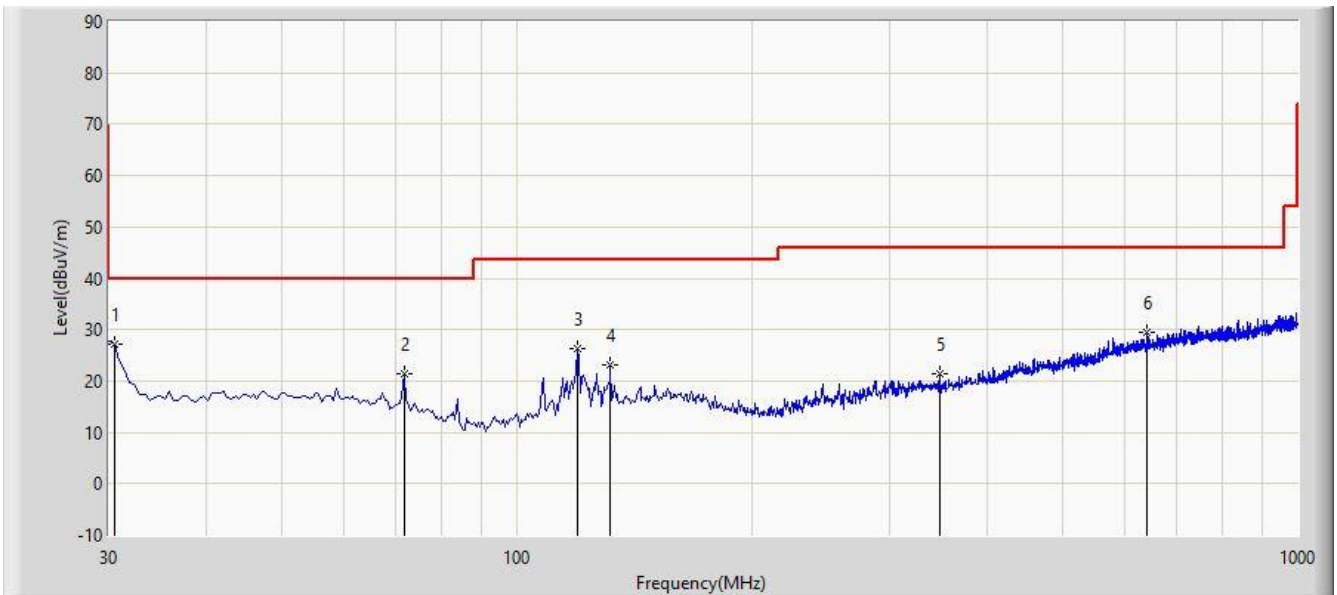

No	Mark	Frequency (MHz)	Measure Level (dBuV/m)	Reading Level (dBuV)	Margin (dB)	Limit (dBuV/m)	Factor (dB)	Type
1	*	30.485	27.147	10.474	-12.853	40.000	16.674	PK
2		71.710	21.451	5.953	-18.549	40.000	15.498	PK
3		119.725	26.218	10.505	-17.282	43.500	15.714	PK
4		131.850	23.116	6.465	-20.384	43.500	16.651	PK
5		347.675	21.385	1.980	-24.615	46.000	19.404	PK
6		641.100	29.593	3.424	-16.407	46.000	26.169	PK

Note 1: Measure Level (dB μ V/m) = Reading Level (dB μ V) + Factor (dB)

Factor (dB) = Cable Loss (dB) + Antenna Factor (dB/m)

Note 2: The amplitude of radiated emissions (frequency range from 9kHz to 30MHz and 18GHz to 25GHz) is that proximity to ambient noise, which also are attenuated more than 20 dB below the permissible value.

Therefore, the data is not presented in the report.

Note 3: QP measurement was not performed when peak measure level was lower than the QP limit.

Site: WZ-AC1	Time: 2021/06/23
Limit: FCC_Part15.209_RSE(3m)	Engineer: Tommy Tang
Probe: WZ-AC1_VULB 9168 _30-1000MHz	Polarity: Vertical
EUT: Wireless Headphones	Power: By Battery
Test Mode: Transmit by BLE at channel 2480MHz	

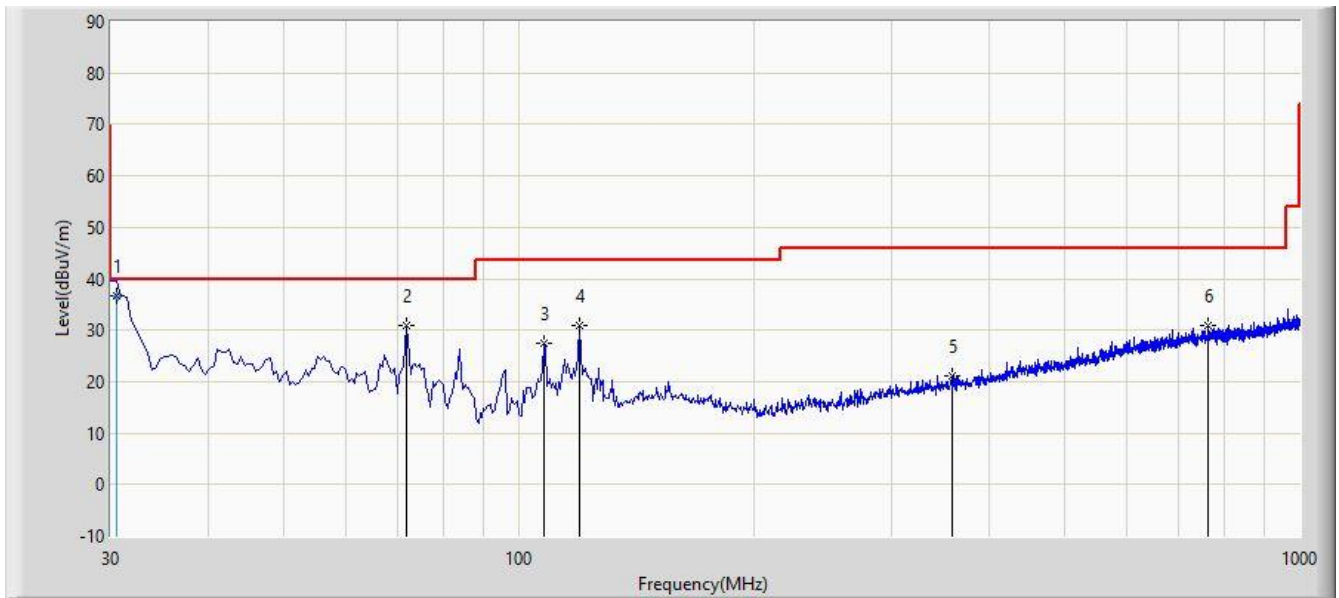

No	Mark	Frequency (MHz)	Measure Level (dBuV/m)	Reading Level (dBuV)	Margin (dB)	Limit (dBuV/m)	Factor (dB)	Type
1	*	30.485	36.773	20.100	-3.227	40.000	16.674	QP
2		71.710	30.887	15.389	-9.113	40.000	15.498	PK
3		107.600	27.484	12.936	-16.016	43.500	14.548	PK
4		119.725	30.791	15.078	-12.709	43.500	15.714	PK
5		358.345	21.234	1.636	-24.766	46.000	19.598	PK
6		763.805	30.873	2.667	-15.127	46.000	28.206	PK

Note 1: Measure Level (dB μ V/m) = Reading Level (dB μ V) + Factor (dB)

Factor (dB) = Cable Loss (dB) + Antenna Factor (dB/m)

Note 2: The amplitude of radiated emissions (frequency range from 9kHz to 30MHz and 18GHz to 25GHz) is that proximity to ambient noise, which also are attenuated more than 20 dB below the permissible value.

Therefore, the data is not presented in the report.

Note 3: QP measurement was not performed when peak measure level was lower than the QP limit.

5.7. Radiated Restricted Band Edge Measurement

5.7.1. Test Limit

For 15.205 requirement:

Radiated emissions which fall in the restricted bands, as defined in Section 15.205(a) of FCC part 15, must also comply with the radiated emission limits specified in Section 15.209(a).

Frequency (MHz)	Frequency (MHz)	Frequency (MHz)	Frequency (GHz)
0.090 - 0.110	16.42 - 16.423	399.9 - 410	4.5 - 5.15
¹ 0.495 - 0.505	16.69475 - 16.69525	608 - 614	5.35 - 5.46
2.1735 - 2.1905	16.80425 - 16.80475	960 - 1240	7.25 - 7.75
4.125 - 4.128	25.5 - 25.67	1300 - 1427	8.025 - 8.5
4.17725 - 4.17775	37.5 - 38.25	1435 - 1626.5	9.0 - 9.2
4.20725 - 4.20775	73 - 74.6	1645.5 - 1646.5	9.3 - 9.5
6.215 - 6.218	74.8 - 75.2	1660 - 1710	10.6 - 12.7
6.26775 - 6.26825	108 - 121.94	1718.8 - 1722.2	13.25 - 13.4
6.31175 - 6.31225	123 - 138	2200 - 2300	14.47 - 14.5
8.291 - 8.294	149.9 - 150.05	2310 - 2390	15.35 - 16.2
8.362 - 8.366	156.52475 - 156.52525	2483.5 - 2500	17.7 - 21.4
8.37625 - 8.38675	156.7 - 156.9	2690 - 2900	22.01 - 23.12
8.41425 - 8.41475	162.0125 - 167.17	3260 - 3267	23.6 - 24.0
12.29 - 12.293	167.72 - 173.2	3332 - 3339	31.2 - 31.8
12.51975 - 12.52025	240 - 285	3345.8 - 3358	36.43 - 36.5
12.57675 - 12.57725	322 - 335.4	3600 - 4400	(²)
13.36 - 13.41	--	--	--

All out of band emissions appearing in a restricted band as specified in Section 15.205 of the Title 47 CFR must not exceed the limits shown in Table per Section 15.209.

FCC Part 15 Subpart C Paragraph 15.209		
Frequency [MHz]	Field Strength [uV/m]	Measured Distance [Meters]
0.009 - 0.490	2400/F (kHz)	300
0.490 - 1.705	24000/F (kHz)	30
1.705 - 30	30	30
30 - 88	100	3
88 - 216	150	3
216 - 960	200	3
Above 960	500	3

5.7.2. Test Procedure Used

ANSI C63.10-2013 - Section 6.3 & 6.6 & 11.13

5.7.3. Test Setting

Peak Field Strength Measurements

1. Analyzer center frequency was set to the frequency of the radiated spurious emission of interest
2. RBW = 1MHz
3. VBW = 3MHz
4. Detector = peak
5. Sweep time = auto couple
6. Trace mode = max hold
7. Trace was allowed to stabilize

Average Field Strength Measurements

1. Analyzer center frequency was set to the frequency of the radiated spurious emission of interest
2. RBW = 1MHz
3. VBW $\geq 1/T$
4. De As an alternative, the instrument may be set to linear detector mode. Ensure that video filtering is applied in linear voltage domain (rather than in a log or dB domain). Some instruments require linear display mode in order to accomplish this. Others have a setting for Average-VBW Type, which can be set to "Voltage" regardless of the display mode
5. Detector = Peak
6. Sweep time = auto
7. Trace mode = max hold
8. Allow max hold to run for at least 50 times (1/duty cycle) traces

5.7.4. Test Setup

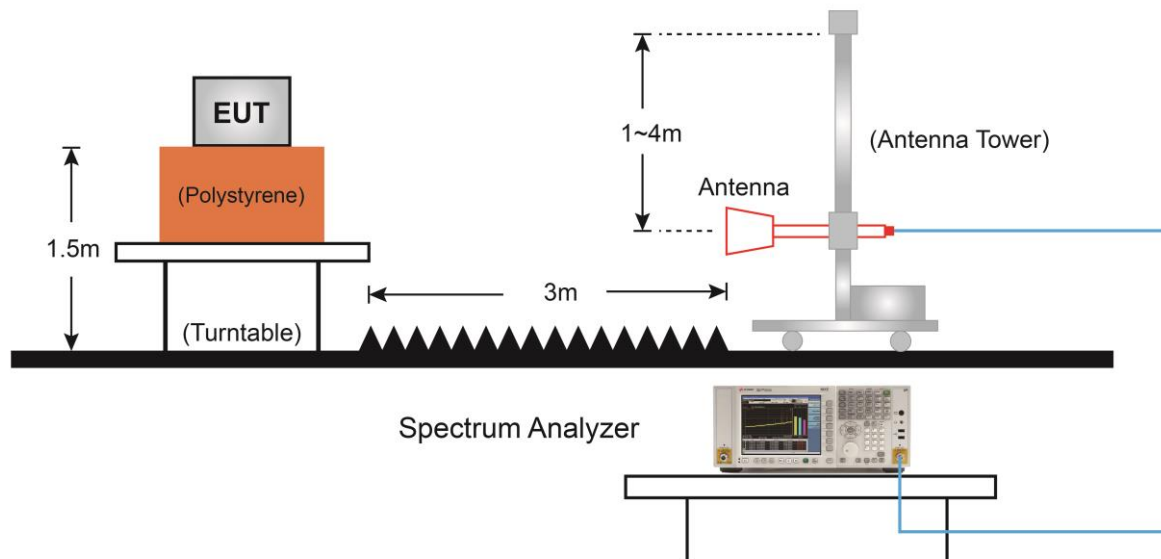

5.7.5. Test Result

Site: WZ-AC1	Time: 2021/06/22 - 21:59
Limit: FCC_Part15.209_RE(3m)	Engineer: Tommy Tang
Probe: WZ-AC1_BBHA9120D_1-18GHz	Polarity: Horizontal
EUT: Wireless Headphones	Power: By Battery
Test Mode: Transmit by BLE 1M at Channel 2402MHz	

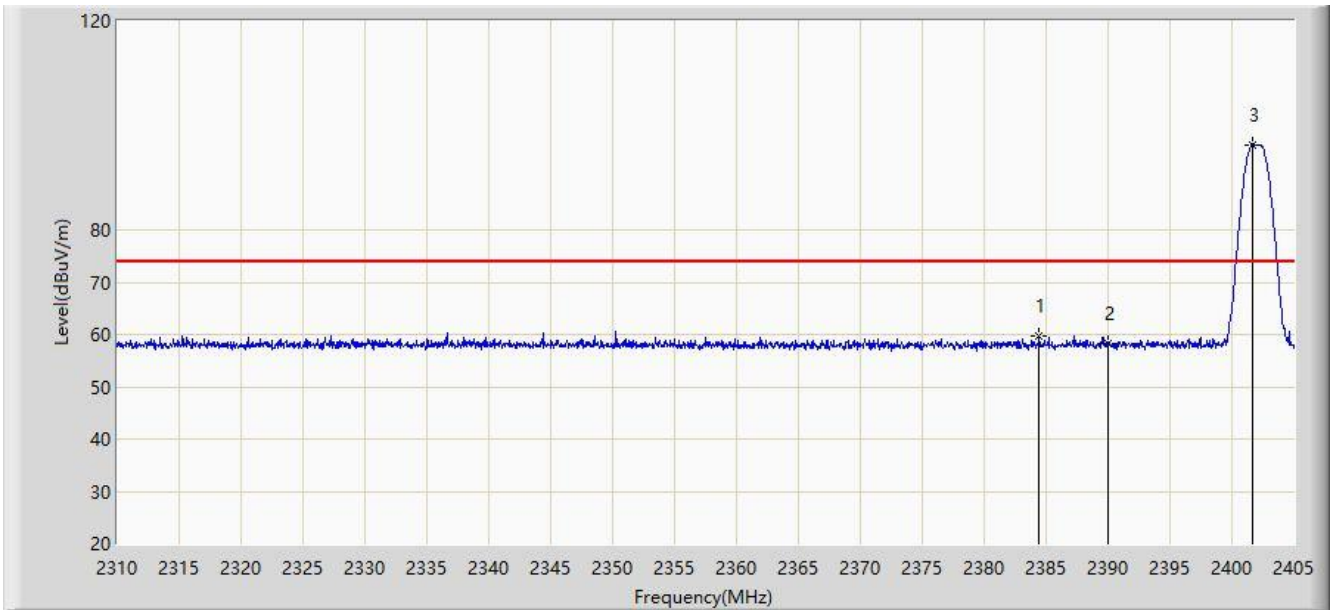

No	Flag	Mark	Frequency (MHz)	Measure Level (dBuV/m)	Reading Level (dBuV)	Margin (dB)	Limit (dBuV/m)	Factor (dB)	Type
1			2384.433	59.631	28.592	-14.369	74.000	31.039	PK
2			2390.000	58.364	27.331	-15.636	74.000	31.034	PK
3		*	2401.627	96.284	65.275	N/A	N/A	31.009	PK

Note: Measure Level (dB μ V/m) = Reading Level (dB μ V) + Factor (dB)

Factor (dB) = Cable Loss (dB) + Antenna Factor (dB/m)

Site: WZ-AC1	Time: 2021/06/22 - 22:03
Limit: FCC_Part15.209_RE(3m)	Engineer: Tommy Tang
Probe: WZ-AC1_BBHA9120D_1-18GHz	Polarity: Horizontal
EUT: Wireless Headphones	Power: By Battery
Test Mode: Transmit by BLE 1M at Channel 2402MHz	

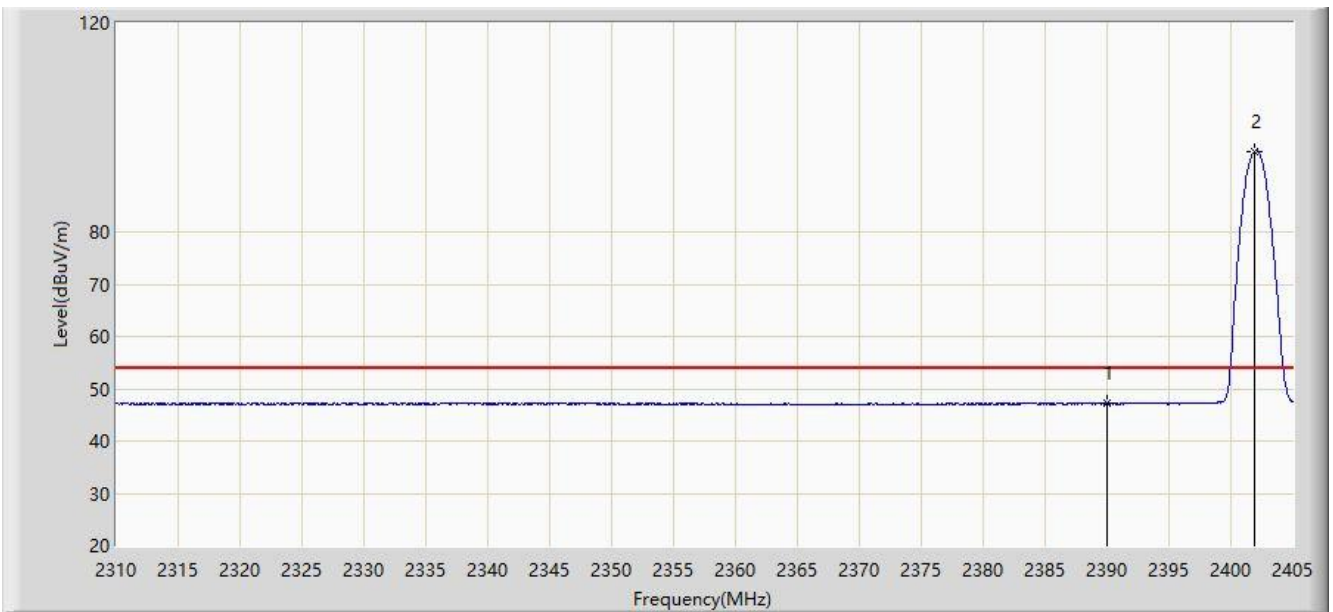

No	Flag	Mark	Frequency (MHz)	Measure Level (dBuV/m)	Reading Level (dBuV)	Margin (dB)	Limit (dBuV/m)	Factor (dB)	Type
1			2390.000	47.168	16.135	-6.832	54.000	31.034	AV
2		*	2401.865	95.322	64.313	N/A	N/A	31.009	AV

Note: Measure Level (dB μ V/m) = Reading Level (dB μ V) + Factor (dB)

Factor (dB) = Cable Loss (dB) + Antenna Factor (dB/m)

Site: WZ-AC1	Time: 2021/06/22 - 22:06
Limit: FCC_Part15.209_RE(3m)	Engineer: Tommy Tang
Probe: WZ-AC1_BBHA9120D_1-18GHz	Polarity: Vertical
EUT: Wireless Headphones	Power: By Battery
Test Mode: Transmit by BLE 1M at Channel 2402MHz	

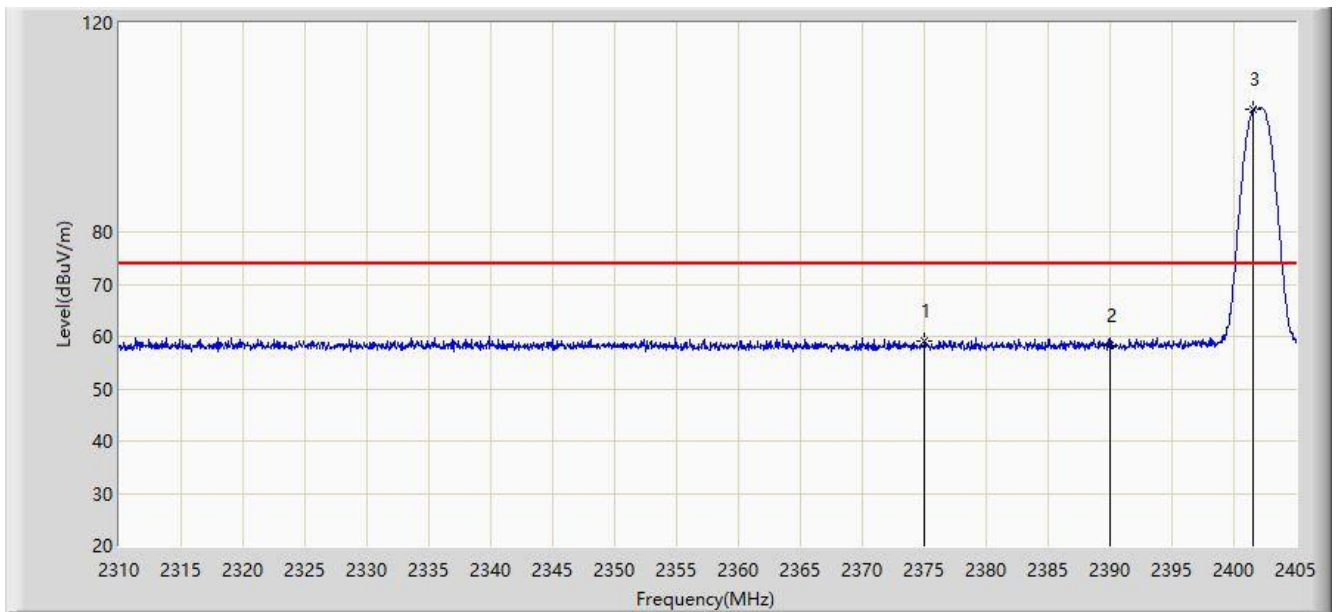

No	Flag	Mark	Frequency (MHz)	Measure Level (dBuV/m)	Reading Level (dBuV)	Margin (dB)	Limit (dBuV/m)	Factor (dB)	Type
1			2375.028	59.127	28.080	-14.873	74.000	31.046	PK
2			2390.000	58.373	27.340	-15.627	74.000	31.034	PK
3		*	2401.580	103.477	72.468	N/A	N/A	31.009	PK

Note: Measure Level (dB μ V/m) = Reading Level (dB μ V) + Factor (dB)

Factor (dB) = Cable Loss (dB) + Antenna Factor (dB/m)

Site: WZ-AC1	Time: 2021/06/22 - 22:04
Limit: FCC_Part15.209_RE(3m)	Engineer: Tommy Tang
Probe: WZ-AC1_BBHA9120D_1-18GHz	Polarity: Vertical
EUT: Wireless Headphones	Power: By Battery
Test Mode: Transmit by BLE 1M at Channel 2402MHz	

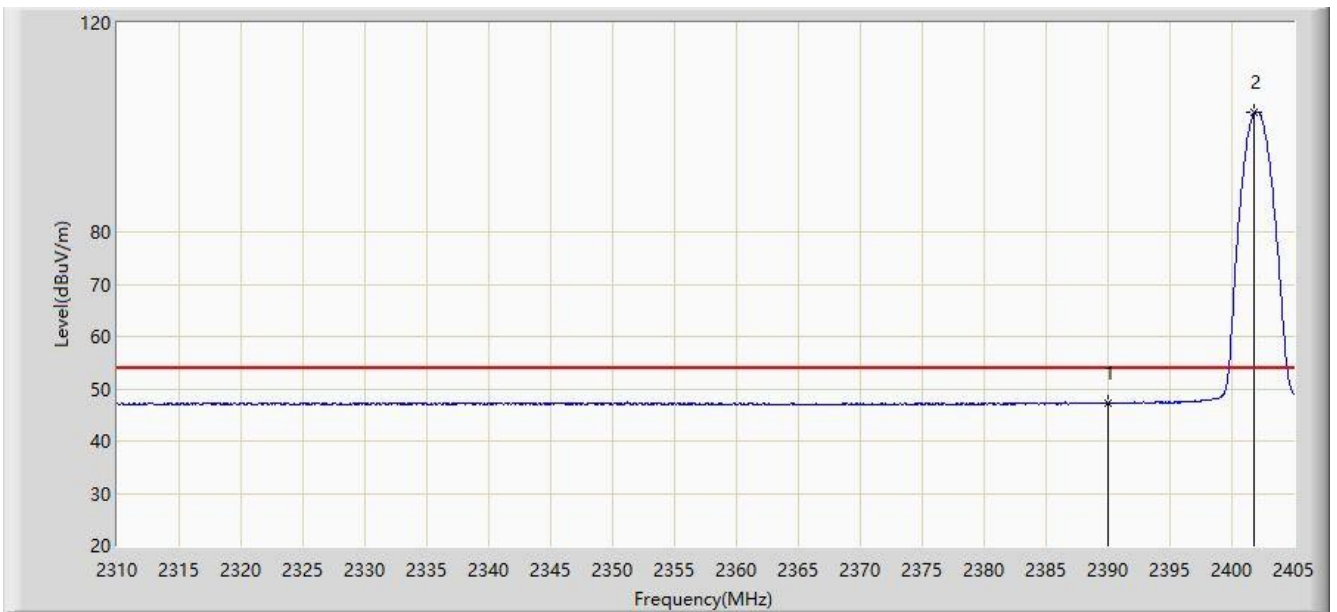

No	Flag	Mark	Frequency (MHz)	Measure Level (dBuV/m)	Reading Level (dBuV)	Margin (dB)	Limit (dBuV/m)	Factor (dB)	Type
1			2390.000	47.181	16.148	-6.819	54.000	31.034	AV
2		*	2401.817	102.783	71.774	N/A	N/A	31.009	AV

Note: Measure Level (dB μ V/m) = Reading Level (dB μ V) + Factor (dB)

Factor (dB) = Cable Loss (dB) + Antenna Factor (dB/m)

Site: WZ-AC1	Time: 2021/06/22 - 22:08
Limit: FCC_Part15.209_RE(3m)	Engineer: Tommy Tang
Probe: WZ-AC1_BBHA9120D_1-18GHz	Polarity: Horizontal
EUT: Wireless Headphones	Power: By Battery
Test Mode: Transmit by BLE 1M at Channel 2480MHz	

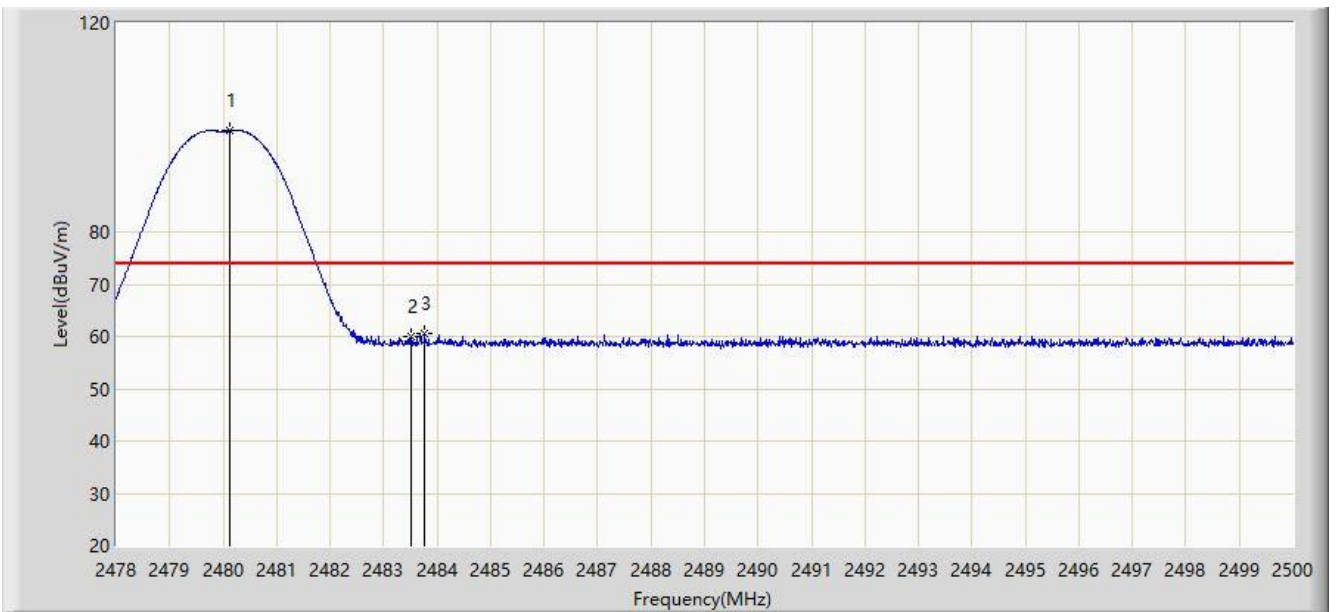

No	Flag	Mark	Frequency (MHz)	Measure Level (dBuV/m)	Reading Level (dBuV)	Margin (dB)	Limit (dBuV/m)	Factor (dB)	Type
1		*	2480.134	99.355	68.478	N/A	N/A	30.877	PK
2			2483.500	60.066	29.178	-13.934	74.000	30.888	PK
3			2483.775	60.600	29.711	-13.400	74.000	30.889	PK

Note: Measure Level (dB μ V/m) = Reading Level (dB μ V) + Factor (dB)

Factor (dB) = Cable Loss (dB) + Antenna Factor (dB/m)

Site: WZ-AC1	Time: 2021/06/22 - 22:13
Limit: FCC_Part15.209_RE(3m)	Engineer: Tommy Tang
Probe: WZ-AC1_BBHA9120D_1-18GHz	Polarity: Horizontal
EUT: Wireless Headphones	Power: By Battery
Test Mode: Transmit by BLE 1M at Channel 2480MHz	

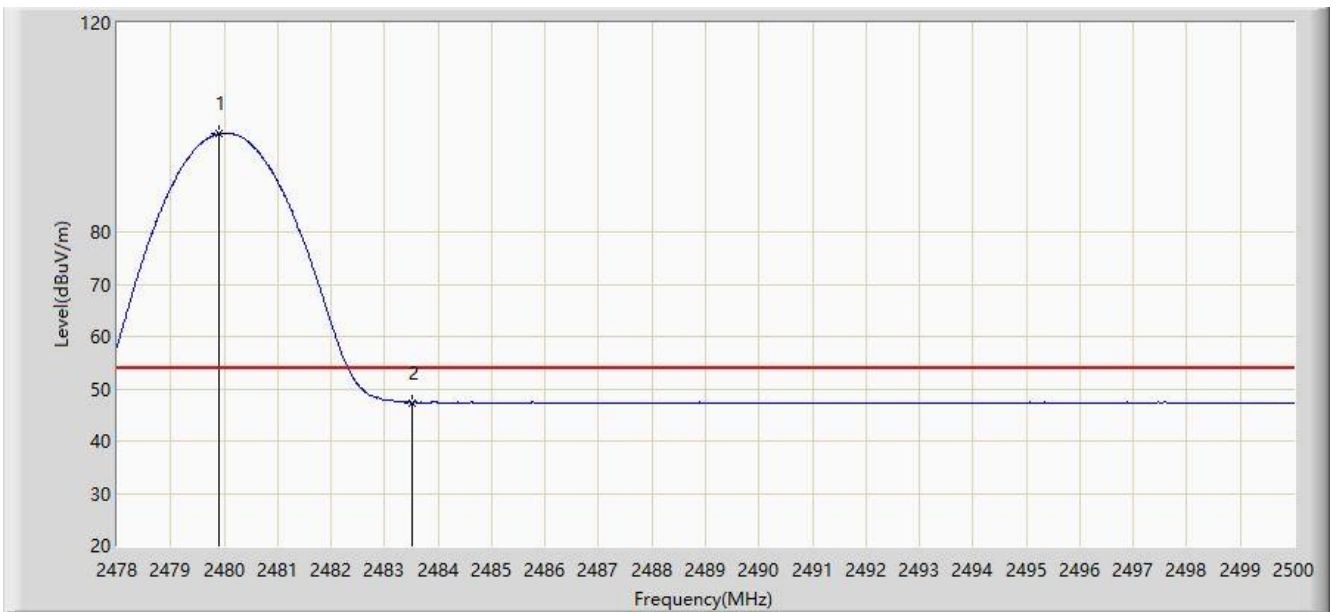

No	Flag	Mark	Frequency (MHz)	Measure Level (dBuV/m)	Reading Level (dBuV)	Margin (dB)	Limit (dBuV/m)	Factor (dB)	Type
1		*	2479.892	98.756	67.880	N/A	N/A	30.876	AV
2			2483.500	47.382	16.494	-6.618	54.000	30.888	AV

Note: Measure Level (dB μ V/m) = Reading Level (dB μ V) + Factor (dB)

Factor (dB) = Cable Loss (dB) + Antenna Factor (dB/m)

Site: WZ-AC1	Time: 2021/06/22 - 22:16
Limit: FCC_Part15.209_RE(3m)	Engineer: Tommy Tang
Probe: WZ-AC1_BBHA9120D_1-18GHz	Polarity: Vertical
EUT: Wireless Headphones	Power: By Battery
Test Mode: Transmit by BLE 1M at Channel 2480MHz	

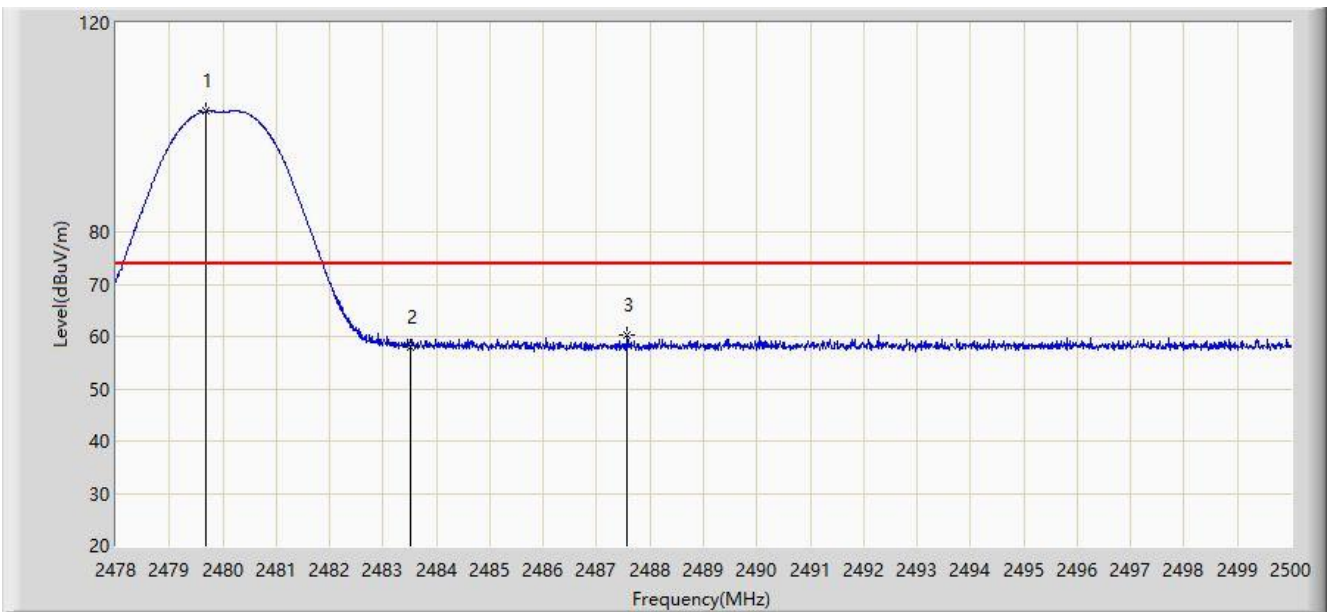

No	Flag	Mark	Frequency (MHz)	Measure Level (dBuV/m)	Reading Level (dBuV)	Margin (dB)	Limit (dBuV/m)	Factor (dB)	Type
1		*	2479.683	103.082	72.206	N/A	N/A	30.876	PK
2			2483.500	58.064	27.176	-15.936	74.000	30.888	PK
3			2487.570	60.224	29.323	-13.776	74.000	30.901	PK

Note: Measure Level (dB μ V/m) = Reading Level (dB μ V) + Factor (dB)

Factor (dB) = Cable Loss (dB) + Antenna Factor (dB/m)

Site: WZ-AC1	Time: 2021/06/22 - 22:15
Limit: FCC_Part15.209_RE(3m)	Engineer: Tommy Tang
Probe: WZ-AC1_BBHA9120D_1-18GHz	Polarity: Vertical
EUT: Wireless Headphones	Power: By Battery
Test Mode: Transmit by BLE 1M at Channel 2480MHz	

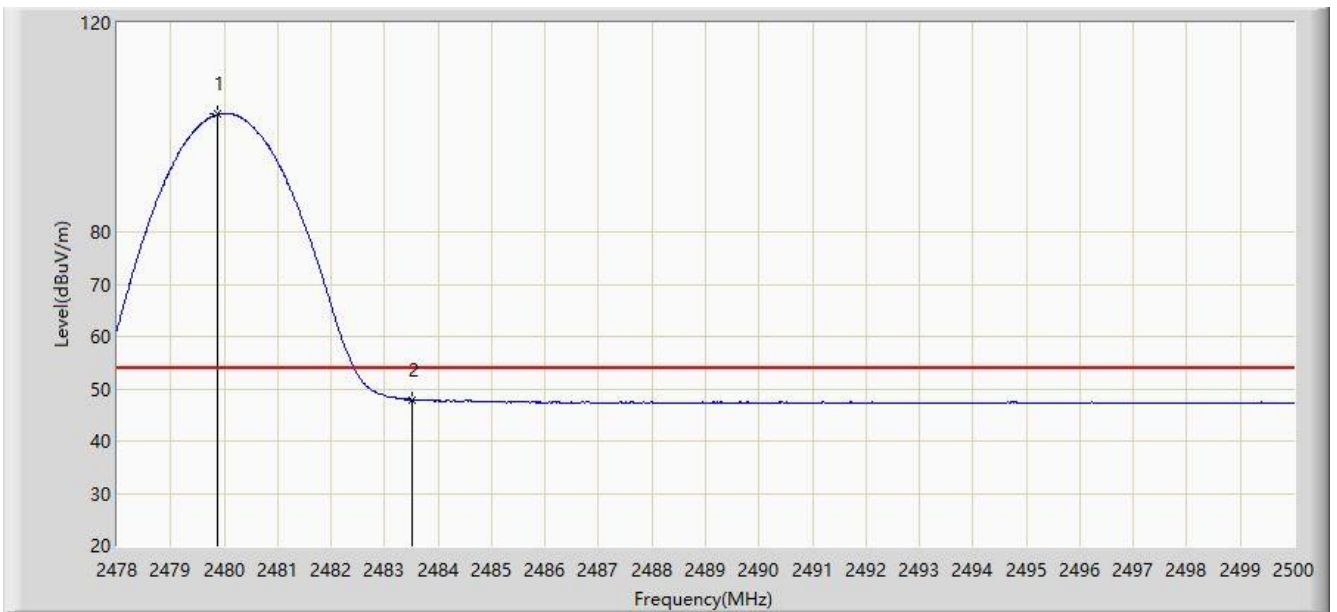

No	Flag	Mark	Frequency (MHz)	Measure Level (dBuV/m)	Reading Level (dBuV)	Margin (dB)	Limit (dBuV/m)	Factor (dB)	Type
1		*	2479.881	102.476	71.600	N/A	N/A	30.876	AV
2			2483.500	47.849	16.961	-6.151	54.000	30.888	AV

Note: Measure Level (dB μ V/m) = Reading Level (dB μ V) + Factor (dB)

Factor (dB) = Cable Loss (dB) + Antenna Factor (dB/m)

Site: WZ-AC1	Time: 2021/06/22 - 22:18
Limit: FCC_Part15.209_RE(3m)	Engineer: Tommy Tang
Probe: WZ-AC1_BBHA9120D_1-18GHz	Polarity: Horizontal
EUT: Wireless Headphones	Power: By Battery
Test Mode: Transmit by BLE 2M at Channel 2402MHz	

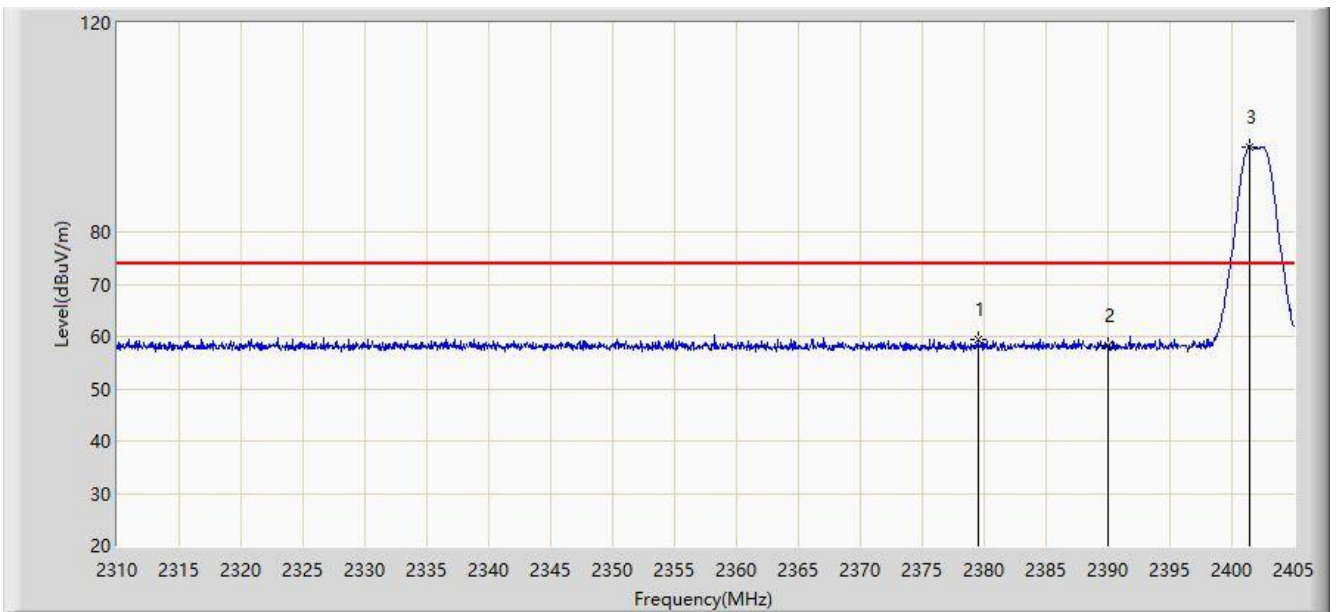

No	Flag	Mark	Frequency (MHz)	Measure Level (dBuV/m)	Reading Level (dBuV)	Margin (dB)	Limit (dBuV/m)	Factor (dB)	Type
1			2379.492	59.384	28.342	-14.616	74.000	31.042	PK
2			2390.000	58.290	27.257	-15.710	74.000	31.034	PK
3		*	2401.390	96.317	65.307	N/A	N/A	31.010	PK

Note: Measure Level (dB μ V/m) = Reading Level (dB μ V) + Factor (dB)

Factor (dB) = Cable Loss (dB) + Antenna Factor (dB/m)

Site: WZ-AC1	Time: 2021/06/22 - 22:20
Limit: FCC_Part15.209_RE(3m)	Engineer: Tommy Tang
Probe: WZ-AC1_BBHA9120D_1-18GHz	Polarity: Horizontal
EUT: Wireless Headphones	Power: By Battery
Test Mode: Transmit by BLE 2M at Channel 2402MHz	

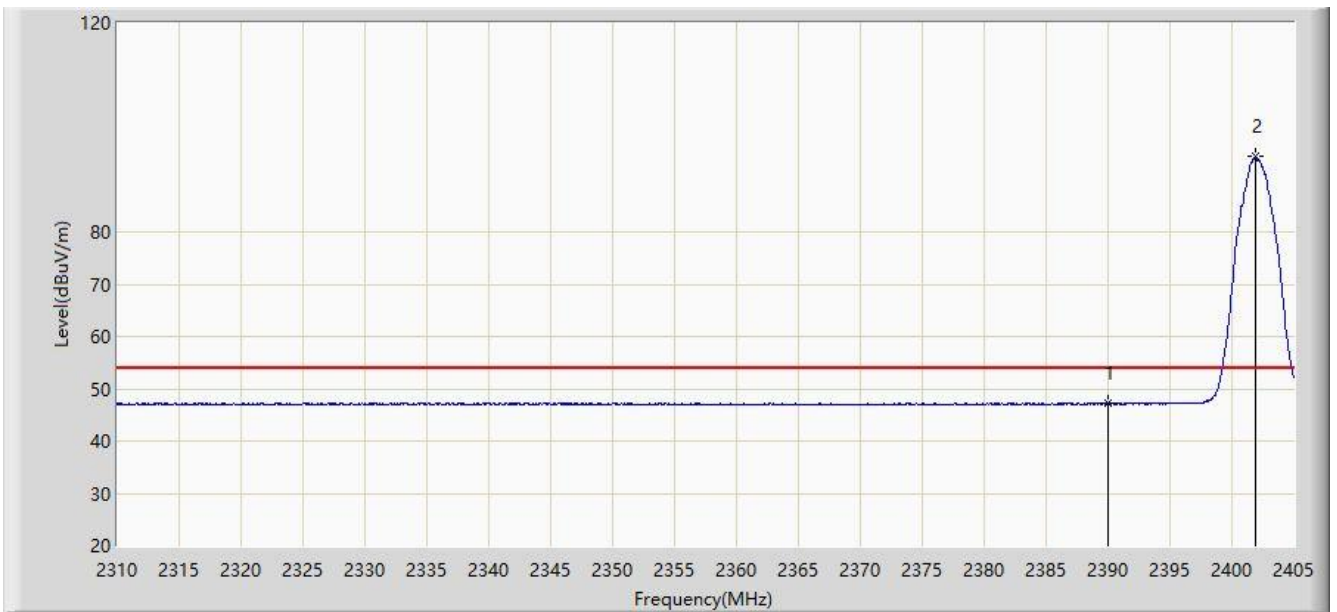

No	Flag	Mark	Frequency (MHz)	Measure Level (dBuV/m)	Reading Level (dBuV)	Margin (dB)	Limit (dBuV/m)	Factor (dB)	Type
1			2390.000	47.129	16.096	-6.871	54.000	31.034	AV
2		*	2401.913	94.394	63.386	N/A	N/A	31.009	AV

Note: Measure Level (dB μ V/m) = Reading Level (dB μ V) + Factor (dB)

Factor (dB) = Cable Loss (dB) + Antenna Factor (dB/m)

Site: WZ-AC1	Time: 2021/06/22 - 22:23
Limit: FCC_Part15.209_RE(3m)	Engineer: Tommy Tang
Probe: WZ-AC1_BBHA9120D_1-18GHz	Polarity: Vertical
EUT: Wireless Headphones	Power: By Battery
Test Mode: Transmit by BLE 2M at Channel 2402MHz	

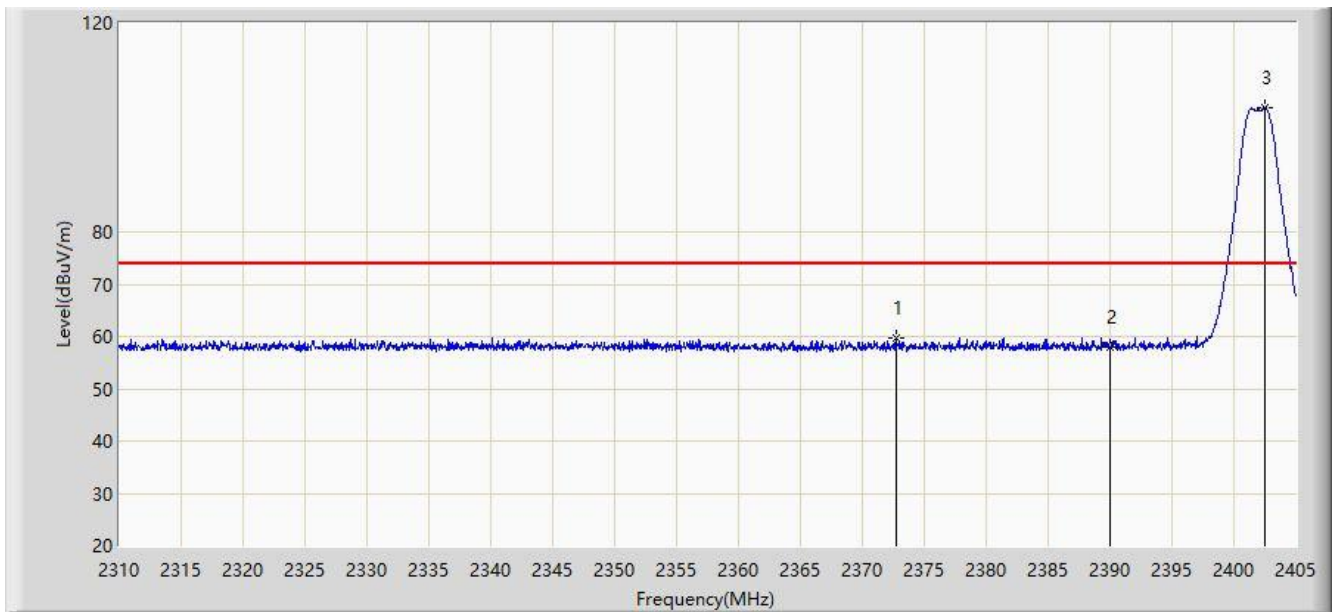

No	Flag	Mark	Frequency (MHz)	Measure Level (dBuV/m)	Reading Level (dBuV)	Margin (dB)	Limit (dBuV/m)	Factor (dB)	Type
1			2372.700	59.780	28.730	-14.220	74.000	31.050	PK
2			2390.000	57.851	26.818	-16.149	74.000	31.034	PK
3		*	2402.482	103.712	72.706	N/A	N/A	31.006	PK

Note: Measure Level (dB μ V/m) = Reading Level (dB μ V) + Factor (dB)

Factor (dB) = Cable Loss (dB) + Antenna Factor (dB/m)

Site: WZ-AC1	Time: 2021/06/22 - 22:22
Limit: FCC_Part15.209_RE(3m)	Engineer: Tommy Tang
Probe: WZ-AC1_BBHA9120D_1-18GHz	Polarity: Vertical
EUT: Wireless Headphones	Power: By Battery
Test Mode: Transmit by BLE 2M at Channel 2402MHz	

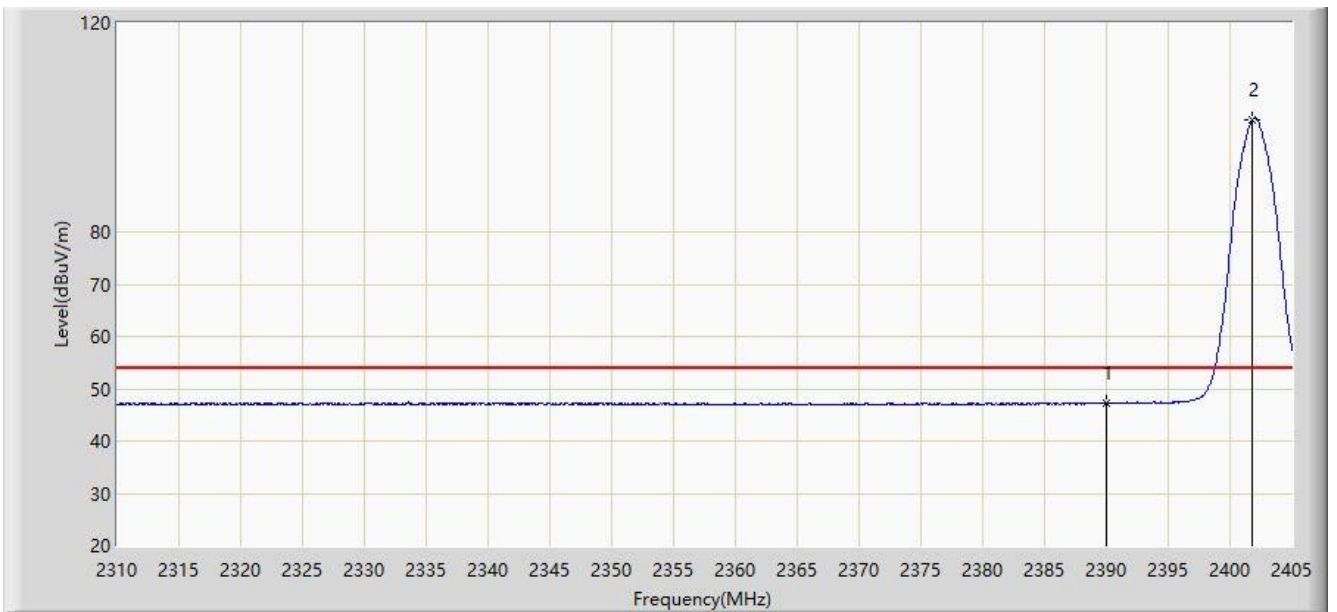

No	Flag	Mark	Frequency (MHz)	Measure Level (dBuV/m)	Reading Level (dBuV)	Margin (dB)	Limit (dBuV/m)	Factor (dB)	Type
1			2390.000	47.216	16.183	-6.784	54.000	31.034	AV
2		*	2401.817	101.543	70.534	N/A	N/A	31.009	AV

Note: Measure Level (dB μ V/m) = Reading Level (dB μ V) + Factor (dB)

Factor (dB) = Cable Loss (dB) + Antenna Factor (dB/m)

Site: WZ-AC1	Time: 2021/06/22 - 22:26
Limit: FCC_Part15.209_RE(3m)	Engineer: Tommy Tang
Probe: WZ-AC1_BBHA9120D_1-18GHz	Polarity: Horizontal
EUT: Wireless Headphones	Power: By Battery
Test Mode: Transmit by BLE 2M at Channel 2480MHz	

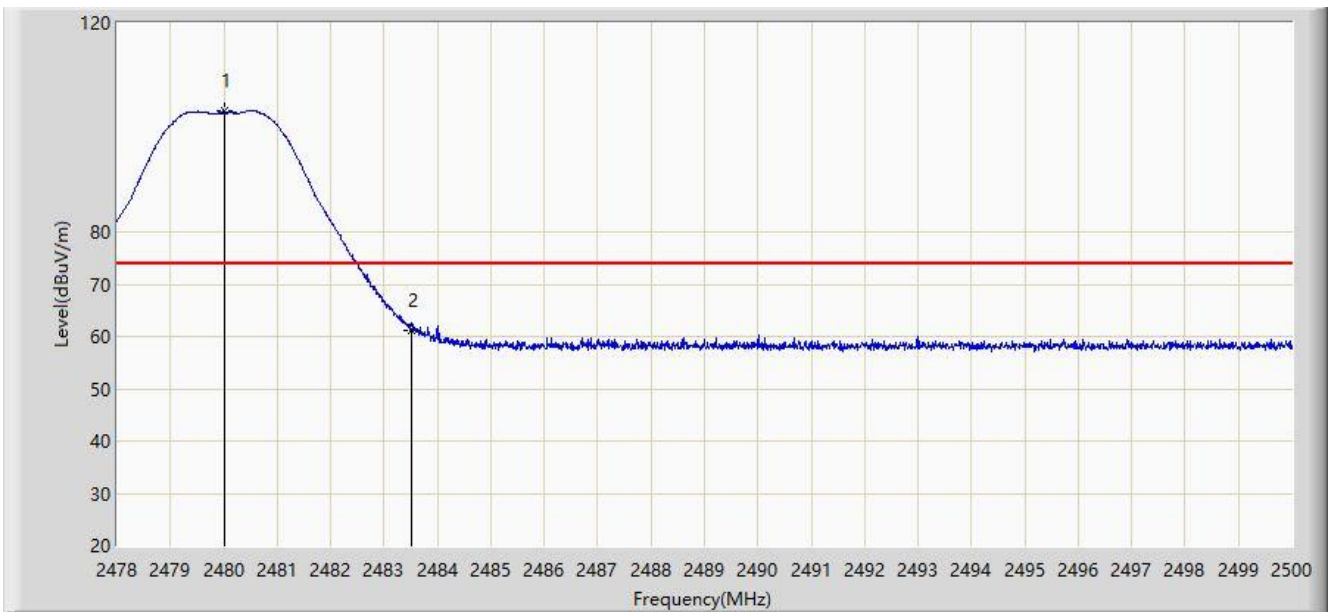

No	Flag	Mark	Frequency (MHz)	Measure Level (dBuV/m)	Reading Level (dBuV)	Margin (dB)	Limit (dBuV/m)	Factor (dB)	Type
1		*	2480.002	103.108	72.231	N/A	N/A	30.877	PK
2			2483.500	61.303	30.415	-12.697	74.000	30.888	PK

Note: Measure Level (dB μ V/m) = Reading Level (dB μ V) + Factor (dB)

Factor (dB) = Cable Loss (dB) + Antenna Factor (dB/m)

Site: WZ-AC1	Time: 2021/06/22 - 22:30
Limit: FCC_Part15.209_RE(3m)	Engineer: Tommy Tang
Probe: WZ-AC1_BBHA9120D_1-18GHz	Polarity: Horizontal
EUT: Wireless Headphones	Power: By Battery
Test Mode: Transmit by BLE 2M at Channel 2480MHz	

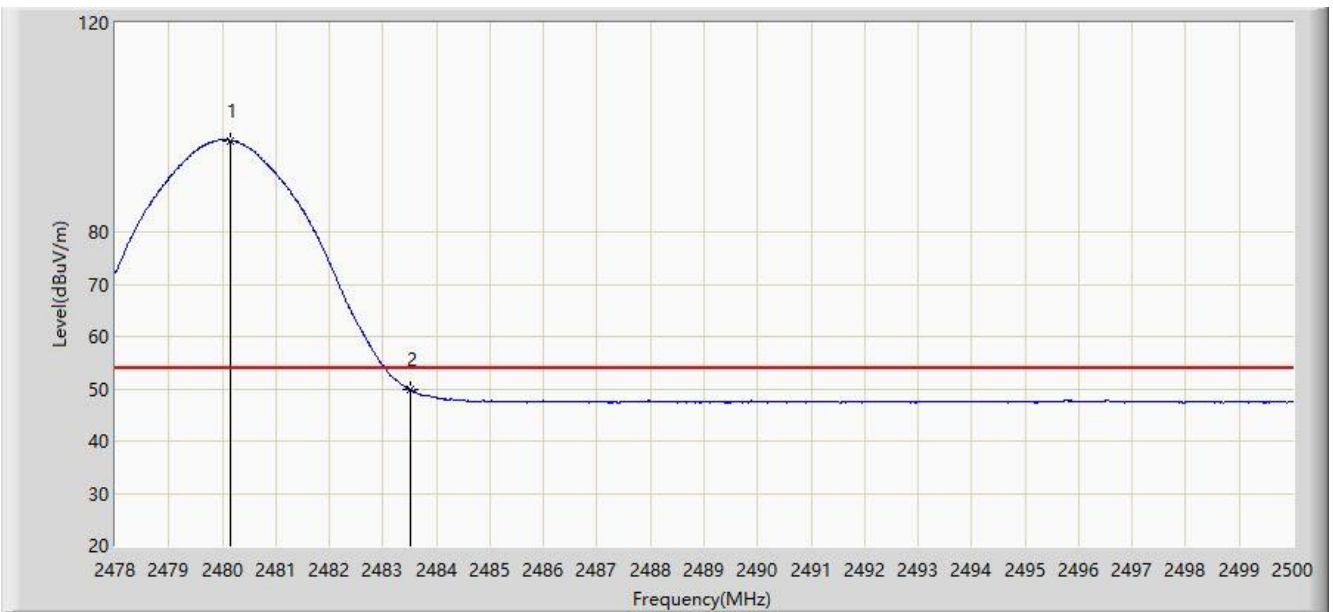

No	Flag	Mark	Frequency (MHz)	Measure Level (dBuV/m)	Reading Level (dBuV)	Margin (dB)	Limit (dBuV/m)	Factor (dB)	Type
1		*	2480.156	97.487	66.610	N/A	N/A	30.877	AV
2			2483.500	49.853	18.965	-4.147	54.000	30.888	AV

Note: Measure Level (dB μ V/m) = Reading Level (dB μ V) + Factor (dB)

Factor (dB) = Cable Loss (dB) + Antenna Factor (dB/m)

Site: WZ-AC1	Time: 2021/06/22 - 22:33
Limit: FCC_Part15.209_RE(3m)	Engineer: Tommy Tang
Probe: WZ-AC1_BBHA9120D_1-18GHz	Polarity: Vertical
EUT: Wireless Headphones	Power: By Battery
Test Mode: Transmit by BLE 2M at Channel 2480MHz	

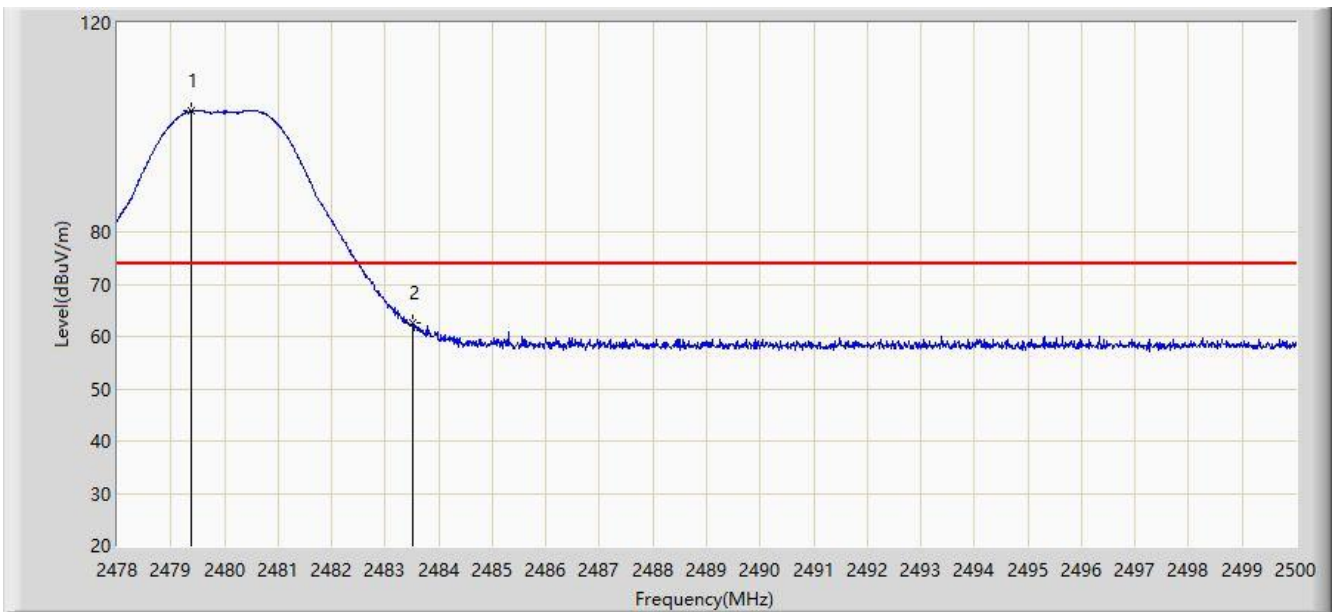

No	Flag	Mark	Frequency (MHz)	Measure Level (dBuV/m)	Reading Level (dBuV)	Margin (dB)	Limit (dBuV/m)	Factor (dB)	Type
1		*	2479.386	103.102	72.227	N/A	N/A	30.874	PK
2			2483.500	62.495	31.607	-11.505	74.000	30.888	PK

Note: Measure Level (dB μ V/m) = Reading Level (dB μ V) + Factor (dB)

Factor (dB) = Cable Loss (dB) + Antenna Factor (dB/m)

Site: WZ-AC1	Time: 2021/06/22 - 22:32
Limit: FCC_Part15.209_RE(3m)	Engineer: Tommy Tang
Probe: WZ-AC1_BBHA9120D_1-18GHz	Polarity: Vertical
EUT: Wireless Headphones	Power: By Battery
Test Mode: Transmit by BLE 2M at Channel 2480MHz	

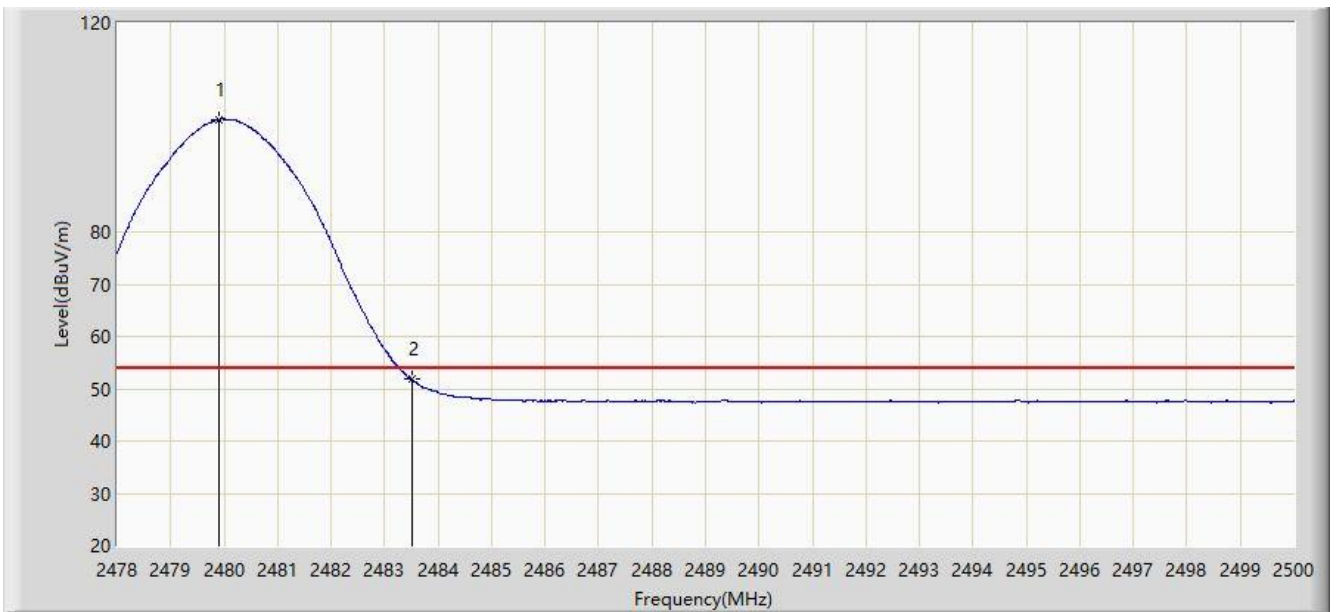

No	Flag	Mark	Frequency (MHz)	Measure Level (dBuV/m)	Reading Level (dBuV)	Margin (dB)	Limit (dBuV/m)	Factor (dB)	Type
1		*	2479.914	101.535	70.658	N/A	N/A	30.876	AV
2			2483.500	51.768	20.880	-2.232	54.000	30.888	AV

Note: Measure Level (dB μ V/m) = Reading Level (dB μ V) + Factor (dB)

Factor (dB) = Cable Loss (dB) + Antenna Factor (dB/m)

5.8. AC Conducted Emissions Measurement

5.8.1. Test Limit

FCC Part 15 Subpart C Paragraph 15.207 Limits		
Frequency (MHz)	QP (dB μ V)	Average (dB μ V)
0.15 - 0.50	66 - 56	56 - 46
0.50 - 5.0	56	46
5.0 - 30	60	50

Note 1: The lower limit shall apply at the transition frequencies.

Note 2: The limit decreases linearly with the logarithm of the frequency in the range 0.15MHz to 0.5MHz.

5.8.2. Test Setup

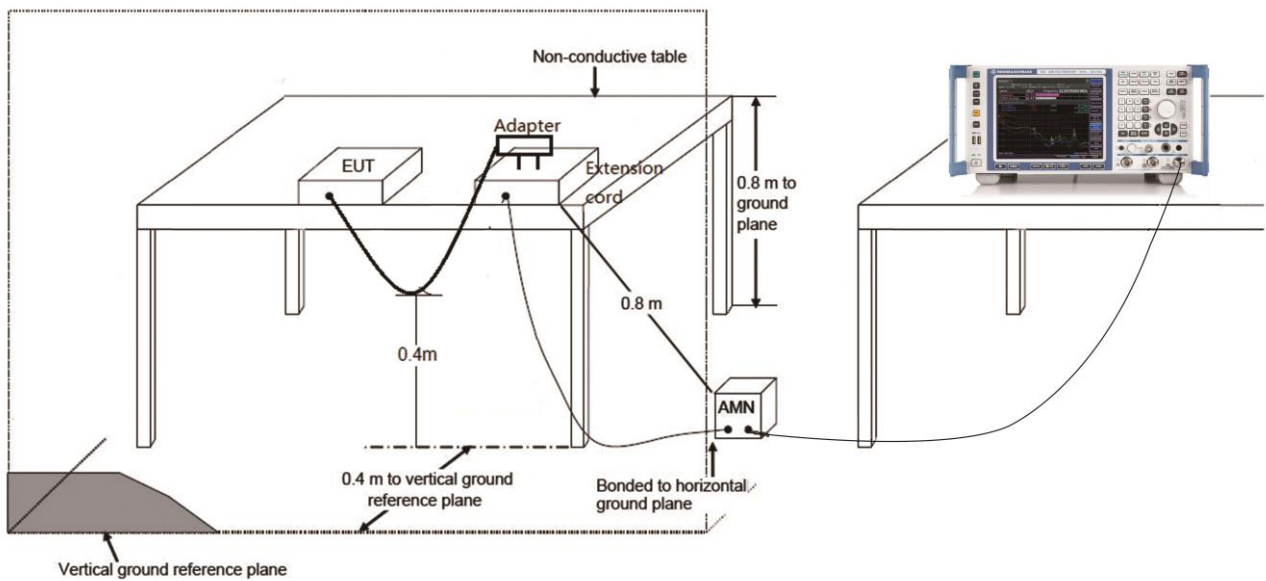

5.8.3. Test Result

Site: WZ-SR2	Time: 2021/06/24 - 17:28
Limit: FCC_Part15.207_CE_AC Power	Engineer: Hyde Yu
Probe: ENV216_101683_Filter Off	Polarity: Line
EUT: Wireless Headphones	Power: AC 120V/60Hz
Test Mode 1	

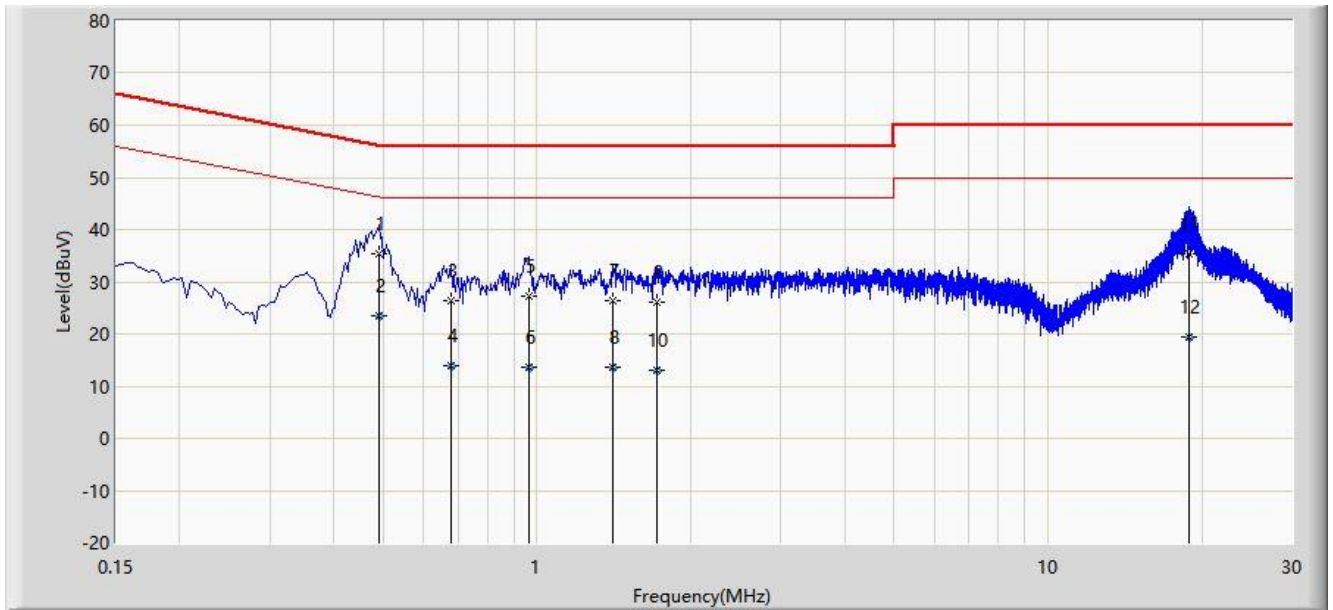

No	Flag	Mark	Frequency (MHz)	Measure Level (dBuV)	Reading Level (dBuV)	Margin (dB)	Limit (dBuV)	Factor (dB)	Type
1		*	0.490	35.291	25.277	-20.877	56.168	10.014	QP
2			0.490	23.440	13.426	-22.728	46.168	10.014	AV
3			0.678	26.342	16.306	-29.658	56.000	10.036	QP
4			0.678	13.870	3.834	-32.130	46.000	10.036	AV
5			0.966	27.228	17.152	-28.772	56.000	10.076	QP
6			0.966	13.649	3.574	-32.351	46.000	10.076	AV
7			1.410	26.291	16.174	-29.709	56.000	10.117	QP
8			1.410	13.708	3.591	-32.292	46.000	10.117	AV
9			1.718	25.993	15.848	-30.007	56.000	10.145	QP
10			1.718	13.090	2.945	-32.910	46.000	10.145	AV
11			18.858	35.443	19.934	-24.557	60.000	15.509	QP
12			18.858	19.332	3.822	-30.668	50.000	15.509	AV

Note: Measure Level (dBμV) = Reading Level (dBμV) + Factor (dB)

Factor (dB) = Cable Loss (dB) + LISN Factor (dB)

Site: WZ-SR2	Time: 2021/06/24 - 17:32
Limit: FCC_Part15.207_CE_AC Power	Engineer: Hyde Yu
Probe: ENV216_101683_Filter Off	Polarity: Neutral
EUT: Wireless Headphones	Power: AC 120V/60Hz
Test Mode 1	

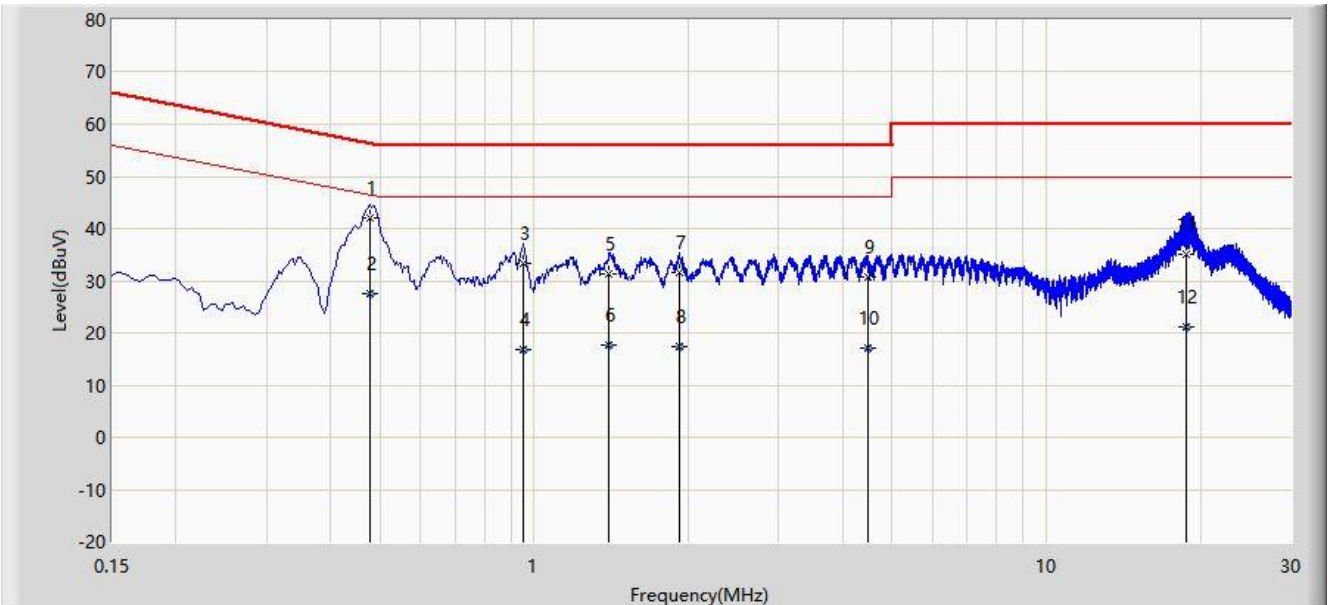

No	Flag	Mark	Frequency (MHz)	Measure Level (dBuV)	Reading Level (dBuV)	Margin (dB)	Limit (dBuV)	Factor (dB)	Type
1		*	0.478	42.056	32.008	-14.317	56.374	10.048	QP
2			0.478	27.579	17.531	-18.794	46.374	10.048	AV
3			0.954	33.199	23.103	-22.801	56.000	10.096	QP
4			0.954	16.832	6.736	-29.168	46.000	10.096	AV
5			1.402	31.365	21.225	-24.635	56.000	10.140	QP
6			1.402	17.610	7.470	-28.390	46.000	10.140	AV
7			1.918	31.573	21.381	-24.427	56.000	10.192	QP
8			1.918	17.421	7.229	-28.579	46.000	10.192	AV
9			4.470	30.811	19.862	-25.189	56.000	10.950	QP
10			4.470	17.045	6.095	-28.955	46.000	10.950	AV
11			18.746	35.120	19.789	-24.880	60.000	15.332	QP
12			18.746	21.170	5.838	-28.830	50.000	15.332	AV

Note: Measure Level (dBμV) = Reading Level (dBμV) + Factor (dB)

Factor (dB) = Cable Loss (dB) + LISN Factor (dB)

6. CONCLUSION

The data collected relate only the item(s) tested and show that the device is compliance with Part 15C of the FCC rules.

————— The End —————

Appendix A - Test Setup Photograph

Refer to "2106RSU001-UT" file.

Appendix B - EUT Photograph

Refer to "2106RSU001-UE" file.