

MEASUREMENT REPORT

FCC PART 15.247 / Bluetooth-LE

FCC ID: DD4-ITWL
Applicant: Shure Incorporated
Application Type: Certification
Product: True Wireless Earphone
Model No.: ITW-L
Trademark: 
FCC Classification: Digital Transmission System (DTS)
FCC Rule Part(s): Part15 Subpart C (Section 15.247)
Test Procedure(s): ANSI C63.10-2013
Test Date: June 19 ~ 25, 2021

Reviewed By:



Jame Yuan

Approved By:

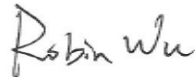

Robin Wu



The test results relate only to the samples tested.

This equipment has been shown to be capable of compliance with the applicable technical standards as indicated in the measurement report and was tested in accordance with the measurement procedures specified in ANSI C63.10-2013. Test results reported herein relate only to the item(s) tested.

The test report shall not be reproduced except in full without the written approval of MRT Technology (Suzhou) Co., Ltd.

Revision History

Report No.	Version	Description	Issue Date	Note
2106RSU032-U2	Rev. 01	Initial Report	06-26-2021	Valid

CONTENTS

Description	Page
1. General Information.....	5
1.1. Applicant.....	5
1.2. Manufacturer	5
1.3. Testing Facility	5
1.4. Product Information	6
1.5. Radio Specification	6
1.6. Working Frequencies.....	7
1.7. Test Mode	7
1.8. Duty Cycle	8
1.9. EMI Suppression Device(s)/Modifications.....	8
1.10. Test Configuration and Software.....	9
1.11. Test Environment Condition.....	9
2. ANTENNA REQUIREMENTS.....	10
3. TEST EQUIPMENT CALIBRATION DATE.....	11
4. MEASUREMENT UNCERTAINTY.....	14
5. TEST RESULT	15
5.1. Summary	15
5.2. 6dB Bandwidth Measurement.....	16
5.2.1. Test Limit	16
5.2.2. Test Procedure used.....	16
5.2.3. Test Setting.....	16
5.2.4. Test Setup.....	16
5.2.5. Test Result.....	17
5.3. Output Power Measurement.....	19
5.3.1. Test Limit	19
5.3.2. Test Procedure Used	19
5.3.3. Test Setting.....	19
5.3.4. Test Setup.....	20
5.3.5. Test Result.....	21
5.4. Power Spectral Density Measurement.....	22
5.4.1. Test Limit	22
5.4.2. Test Procedure Used	22
5.4.3. Test Setting.....	22
5.4.4. Test Setup.....	22
5.4.5. Test Result.....	23

5.5.	Conducted Band Edge and Out-of-Band Emissions.....	25
5.5.1.	Test Limit	25
5.5.2.	Test Procedure Used	25
5.5.3.	Test Setting.....	25
5.5.4.	Test Setup.....	26
5.5.5.	Test Result.....	27
5.6.	Radiated Spurious Emission Measurement	31
5.6.1.	Test Limit	31
5.6.2.	Test Procedure Used	31
5.6.3.	Test Setting.....	31
5.6.4.	Test Setup.....	33
5.6.5.	Test Result.....	34
5.7.	Radiated Restricted Band Edge Measurement	42
5.7.1.	Test Limit	42
5.7.2.	Test Procedure Used	43
5.7.3.	Test Setting.....	43
5.7.4.	Test Setup.....	44
5.7.5.	Test Result.....	45
5.8.	AC Conducted Emissions Measurement.....	61
5.8.1.	Test Limit	61
5.8.2.	Test Setup.....	61
5.8.3.	Test Result.....	62
6.	CONCLUSION.....	64
	Appendix A - Test Setup Photograph	65
	Appendix B - EUT Photograph.....	66

1. General Information

1.1. Applicant

Shure Incorporated
 5800 West Touhy Avenue, Niles, IL 60714-4608, USA

1.2. Manufacturer

Shure Incorporated
 5800 West Touhy Avenue, Niles, IL 60714-4608, USA

1.3. Testing Facility

<input checked="" type="checkbox"/>	<p>Test Site – MRT Suzhou Laboratory</p> <hr/> <p>Laboratory Location (Suzhou – Wuzhong) D8 Building, No.2 Tian'edang Rd., Wuzhong Economic Development Zone, Suzhou, China</p> <p>Laboratory Location (Suzhou – SIP) 4b Building, Liando U Valley, No.200 Xingpu Rd., Shengpu Town, Suzhou Industrial Park, China</p> <hr/> <p>Laboratory Accreditations</p> <p>A2LA: 3628.01 CNAS: L10551 FCC: CN1166 ISED: CN0001 VCCI: R-20025, G-20034, C-20020, T-20020</p>
<input type="checkbox"/>	<p>Test Site – MRT Shenzhen Laboratory</p> <hr/> <p>Laboratory Location (Shenzhen) 1G, Building A, Junxiangda Building, Zhongshanyuan Road West, Nanshan District, Shenzhen, China</p> <hr/> <p>Laboratory Accreditations</p> <p>A2LA: 3628.02 CNAS: L10551 FCC: CN1284 ISED: CN0105</p>
<input type="checkbox"/>	<p>Test Site – MRT Taiwan Laboratory</p> <hr/> <p>Laboratory Location (Taiwan) No. 38, Fuxing 2nd Rd., Guishan Dist., Taoyuan City 333, Taiwan (R.O.C.)</p> <hr/> <p>Laboratory Accreditations</p> <p>TAF: L3261-190725 FCC: 291082, TW3261 ISED: TW3261</p>

1.4. Product Information

Product Name	True Wireless Earphone
Model No.	ITW-L
Bluetooth Version	v5.1 dual mode
Antenna Information	Refer to clause 1.5
Operating Temperature	0 ~ 45 °C
Power Type	Internal Li-ion Battery Input

Note: The information of EUT was provided by the manufacturer, and the accuracy of the information shall be the responsibility of the manufacturer.

1.5. Radio Specification

Bluetooth Frequency	2402~2480MHz
Channel Number	40
Type of modulation	GFSK
Data Rate	Up to 2Mbps
Antenna Type	Monopole Antenna
Antenna Gain	-0.82dBi

Note: For other features of this EUT, test report will be issued separately.

1.6. Working Frequencies

Channel	Frequency	Channel	Frequency	Channel	Frequency
00	2402 MHz	01	2404 MHz	02	2406 MHz
03	2408 MHz	04	2410 MHz	05	2412 MHz
06	2414 MHz	07	2416 MHz	08	2418 MHz
09	2420 MHz	10	2422 MHz	11	2424 MHz
12	2426 MHz	13	2428 MHz	14	2430 MHz
15	2432 MHz	16	2434 MHz	17	2436 MHz
18	2438 MHz	19	2440 MHz	20	2442 MHz
21	2444 MHz	22	2446 MHz	23	2448 MHz
24	2450 MHz	25	2452 MHz	26	2454 MHz
27	2456 MHz	28	2458 MHz	29	2460 MHz
30	2462 MHz	31	2464 MHz	32	2466 MHz
33	2468 MHz	34	2470 MHz	35	2472 MHz
36	2474 MHz	37	2476 MHz	38	2478 MHz
39	2480 MHz	--	--	--	--

1.7. Test Mode

Test Mode	Mode 1: Transmit by BLE-1Mbps
	Mode 2: Transmit by BLE-2Mbps

1.8. Duty Cycle

The maximum achievable duty cycles were determined based on measurements performed on a spectrum analyzer in zero-span mode with RBW = 8MHz, VBW = 50MHz. The RBW and VBW were both greater than 50/T, where T is the minimum transmission duration, and the number of sweep points across T was greater than 100. The duty cycles are as follows:

Test Mode	Duty Cycle
BLE- 1Mbps	61.67%
BLE- 2Mbps	32.11%

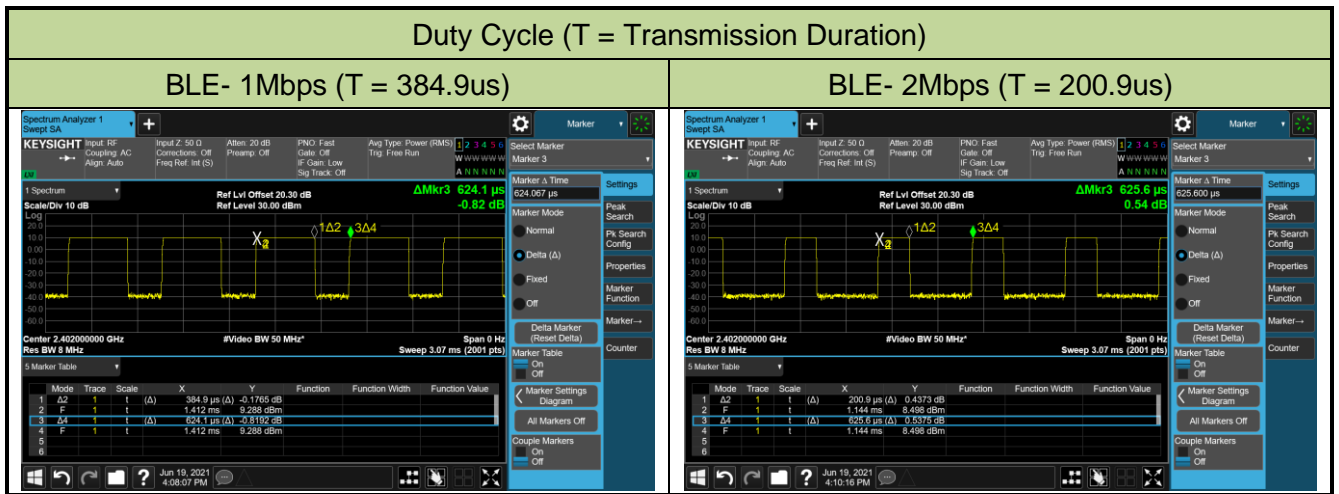

1.9. EMI Suppression Device(s)/Modifications

No EMI suppression device(s) were added and/or no modifications were made during testing.

1.10. Test Configuration and Software

The device was tested per the guidance ANSI C63.10-2013 that was used to reference the appropriate EUT setup for radiated spurious emissions and AC line conducted emission testing.

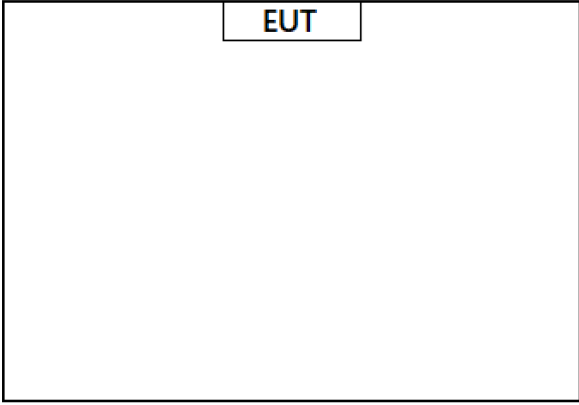
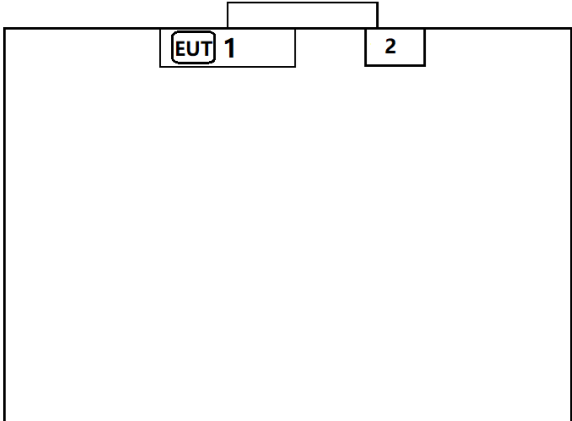
Radiated Spurious Emissions		AC line Conducted Emission	
			
Product	Manufacturer	Model No.	
1 Charging Case	Shure	ITW1	
2 Adapter	Shenzhen Honor Electronic Co., Ltd	ADS-12B-06 05010E	

Note 1: The test utility software used during testing was “BlueTest3”, and the version was 3.2.3.29.

Note 2: Detail power setting refer to operation description.

1.11. Test Environment Condition

Ambient Temperature	15 ~ 35 °C
Relative Humidity	20 ~75 %RH

2. ANTENNA REQUIREMENTS

Excerpt from §15.203 of the FCC Rules/Regulations:

“An intentional radiator antenna shall be designed to ensure that no antenna other than that furnished by the responsible party can be used with the device. The use of a permanently attached antenna or of an antenna that uses a unique coupling to the intentional radiator shall be considered sufficient to comply with the provisions of this section.”

- The antenna of the device is **permanently attached**.
- There are no provisions for connection to an external antenna.

Conclusion:

The unit complies with the requirement of §15.203.

3. TEST EQUIPMENT CALIBRATION DATE

Conducted Emission (WZ-SR2)

Instrument	Manufacturer	Type No.	Asset No.	Cali. Interval	Cali. Due Date
EMI Test Receiver	R&S	ESR3	MRTSUE06909	1 year	2021/11/22
Two-Line V-Network	R&S	ENV216	MRTSUE06002	1 year	2022/06/08
Thermal Hygrometer	testo	608-H1	MRTSUE06404	1 year	2021/07/26

Conducted Emission (SIP-SR2)

Instrument	Manufacturer	Type No.	Asset No.	Cali. Interval	Cali. Due Date
EMI Test Receiver	R&S	ESR3	MRTSUE06613	1 year	2021/07/02
Two-Line V-Network	R&S	ENV216	MRTSUE06003	1 year	2022/06/08
Thermal Hygrometer	testo	608-H1	MRTSUE06621	1 year	2021/12/03

Radiated Emission (WZ-AC1)

Instrument	Manufacturer	Type No.	Asset No.	Cali. Interval	Cali. Due Date
EMI Test Receiver	R&S	ESR7	MRTSUE06001	1 year	2022/01/04
Loop Antenna	Schwarzbeck	FMZB 1519	MRTSUE06025	1 year	2021/11/08
Bilog Period Antenna	Schwarzbeck	VULB 9168	MRTSUE06172	1 year	2021/08/08
Horn Antenna	Schwarzbeck	BBHA 9120D	MRTSUE06023	1 year	2021/09/27
Horn Antenna	Schwarzbeck	BBHA9170	MRTSUE06597	1 year	2021/12/14
Microwave System Amplifier	Agilent	83017A	MRTSUE06076	1 year	2021/11/14
Preamplifier	Schwarzbeck	BBV 9721	MRTSUE06121	1 year	2022/06/10
Thermal Hygrometer	testo	608-H1	MRTSUE06403	1 year	2021/07/26
Anechoic Chamber	TDK	Chamber-AC1	MRTSUE06212	1 year	2022/04/29

Radiated Emission (WZ-AC2)

Instrument	Manufacturer	Type No.	Asset No.	Cali. Interval	Cali. Due Date
MXE EMI Receiver	Keysight	N9038A	MRTSUE06125	1 year	2021/07/02
Loop Antenna	Schwarzbeck	FMZB 1519	MRTSUE06025	1 year	2021/11/08
Bilog Period Antenna	Schwarzbeck	VULB 9162	MRTSUE06022	1 year	2022/05/24
Broad-Band Horn Antenna	Schwarzbeck	BBHA 9120D	MRTSUE06171	1 year	2021/10/25
Horn Antenna	Schwarzbeck	BBHA9170	MRTSUE06597	1 year	2021/12/14
Broadband Coaxial Preamplifier	Schwarzbeck	BBV 9718	MRTSUE06176	1 year	2021/11/14
Thermal Hygrometer	Minggao	ETH529	MRTSUE06170	1 year	2021/12/08
Anechoic Chamber	RIKEN	Chamber-AC2	MRTSUE06213	1 year	2022/04/29

Radiated Emission (SIP-AC1)

Instrument	Manufacturer	Type No.	Asset No.	Cali. Interval	Cali. Due Date
EMI Test Receiver	R&S	ESR3	MRTSUE06612	1 year	2021/07/02
EXA Signal Analyzer	Keysight	N9010B	MRTSUE06559	1 year	2021/07/23
Loop Antenna	Schwarzbeck	FMZB 1519 B	MRTSUE06937	1 year	2022/03/09
Bilog Period Antenna	Schwarzbeck	VULB9168	MRTSUE06645	1 year	2021/08/30
Double Ridged Horn Antenna	R&S	HF907	MRTSUE06610	1 year	2021/08/30
Preamplifier	EMCI	EMC051845SE	MRTSUE06600	1 year	2021/11/09
Thermal Hygrometer	testo	608-H1	MRTSUE06620	1 year	2021/12/03
Anechoic Chamber	RIKEN	SIP-AC1	MRTSUE06554	1 year	2021/12/24

Radiated Emission (SIP-AC2)

Instrument	Manufacturer	Type No.	Asset No.	Cali. Interval	Cali. Due Date
EMI Test Receiver	R&S	ESR3	MRTSUE06613	1 year	2021/07/02
MXA Signal Analyzer	Keysight	N9020B	MRTSUE06604	1 year	2021/09/26
Loop Antenna	Schwarzbeck	FMZB 1519 B	MRTSUE06937	1 year	2022/03/09
Bilog Period Antenna	Schwarzbeck	VULB9168	MRTSUE06646	1 year	2021/08/30
Horn Antenna	Schwarzbeck	BBHA9120D	MRTSUE06648	1 year	2021/11/26
Horn Antenna	Schwarzbeck	BBHA9170	MRTSUE06599	1 year	2021/11/26
Preamplifier	EMCI	EMC051845SE	MRTSUE06644	1 year	2021/11/09
Preamplifier	EMCI	EMC184045SE	MRTSUE06602	1 year	2021/10/12
Thermal Hygrometer	testo	608-H1	MRTSUE06624	1 year	2021/12/03
Anechoic Chamber	RIKEN	SIP-AC2	MRTSUE06781	1 year	2021/12/24

Radiated Emission (SIP-AC3)

Instrument	Manufacturer	Type No.	Asset No.	Cali. Interval	Cali. Due Date
Preamplifier	Schwarzbeck	BBV 9721	MRTSUE06121	1 year	2022/06/10
EMI Test Receiver	R&S	ESR3	MRTSUE06612	1 year	2021/07/02
EXA Signal Analyzer	Keysight	N9010B	MRTSUE06559	1 year	2021/07/23
Loop Antenna	Schwarzbeck	FMZB 1519	MRTSUE06025	1 year	2021/11/08
Bilog Period Antenna	Schwarzbeck	VULB9168	MRTSUE06646	1 year	2021/08/30
Double Ridged Horn Antenna	R&S	HF907	MRTSUE06611	1 year	2021/09/13
Horn Antenna	Schwarzbeck	BBHA9170	MRTSUE06598	1 year	2021/11/26
Preamplifier	EMCI	EMC012645SE	MRTSUE06642	1 year	2022/01/14
Thermal Hygrometer	testo	608-H1	MRTSUE06622	1 year	2021/12/03
Anechoic Chamber	RIKEN	SIP-AC3	MRTSUE06782	1 year	2021/12/24

Conducted Test Equipment (WZ-TR3)

Instrument	Manufacturer	Type No.	Asset No.	Cali. Interval	Cali. Due Date
EXA Signal Analyzer	Agilent	N9020A	MRTSUE06106	1 year	2022/04/13
EXA Signal Analyzer	Keysight	N9010B	MRTSUE06607	1 year	2022/01/06
Power Meter	Agilent	U2021XA	MRTSUE06030	1 year	2021/10/22
USB wideband power sensor	Keysight	U2021XA	MRTSUE06446	1 year	2022/06/08
USB wideband power sensor	Keysight	U2021XA	MRTSUE06447	1 year	2022/06/08
Bluetooth Test Set	Anritsu	MT8852B-042	MRTSUE06389	1 year	2022/06/08
Modulation Analyzer	HP	HP8901A	MRTSUE06098	1 year	2021/09/26
DC Power Supply	GWINSTEK	DPS-3303C	MRTSUE06064	N/A	N/A
Temperature & Humidity Chamber	BAOYT	BYH-150CL	MRTSUE06051	1 year	2021/10/22
Thermal Hygrometer	testo	608-H1	MRTSUE06401	1 year	2021/07/26

Conducted Test Equipment (SIP-TR1)

Instrument	Manufacturer	Type No.	Asset No.	Cali. Interval	Cali. Due Date
EXA Signal Analyzer	KEYSIGHT	N9010B	MRTSUE06603	1 year	2021/11/23
PXA Signal Analyzer	Keysight	N9030B	MRTSUE06395	1 year	2021/08/30
USB wideband power sensor	Agilent	U2021XA	MRTSUE06595	1 year	2021/09/26
USB wideband power sensor	Agilent	U2021XA	MRTSUE06596	1 year	2021/09/26
Temperature Chamber	BAOYT	BYG-408CS	MRTSUE06847	1 year	2022/02/23
Thermal Hygrometer	testo	608-H1	MRTSUE11022	1 year	2021/11/25

Software	Version	Function
EMI Software	V3	EMI Test Software

4. MEASUREMENT UNCERTAINTY

Where relevant, the following test uncertainty levels have been estimated for tests performed on the EUT as specified in CISPR 16-4-2. This uncertainty represents an expanded uncertainty expressed at approximately the 95% confidence level using a coverage factor of $k = 2$.

AC Conducted Emission Measurement
Measurement Uncertainty for a Level of Confidence of 95% ($U=2Uc(y)$): 9kHz~150kHz: 3.74dB 150kHz~30MHz: 3.44dB
Radiated Disturbance
Measurement Uncertainty for a Level of Confidence of 95% ($U=2Uc(y)$): Horizontal: 9kHz~300MHz: 5.04dB 300MHz~1GHz: 4.95dB 1GHz~40GHz: 6.40dB Vertical: 9kHz~300MHz: 5.24dB 300MHz~1GHz: 6.03dB 1GHz~40GHz: 6.40dB
Spurious Emissions, Conducted
Measuring Uncertainty for a Level of Confidence of 95% ($U=2Uc(y)$): 0.78dB
Output Power
Measuring Uncertainty for a Level of Confidence of 95% ($U=2Uc(y)$): 1.13dB
Power Spectrum Density
Measuring Uncertainty for a Level of Confidence of 95% ($U=2Uc(y)$): 1.15dB
Occupied Bandwidth
Measuring Uncertainty for a Level of Confidence of 95% ($U=2Uc(y)$): 0.28%

5. TEST RESULT

5.1. Summary

FCC Part Section(s)	Test Description	Test Limit	Test Condition	Test Result	Reference
15.247(a)(2)	6dB Bandwidth	$\geq 500\text{kHz}$	Conducted	Pass	Section 5.2
15.247(b)(3)	Output Power	$\leq 1\text{Watt}$		Pass	Section 5.3
15.247(e)	Power Spectral Density	$\leq 8\text{dBm} / 3\text{kHz}$		Pass	Section 5.4
15.247(d)	Band Edge / Out-of-Band Emissions	$\geq 20\text{dBc (Peak)}$		Pass	Section 5.5
15.205 15.209	General Field Strength (Restricted Bands and Radiated Emission)	Emissions in restricted bands must meet the radiated limits detailed in 15.209	Radiated	Pass	Section 5.6 Section 5.7
15.207	AC Conducted Emissions 150kHz - 30MHz	< FCC 15.207 limits	Line Conducted	Pass	Section 5.8

Notes:

- 1) The analyzer plots shown in this section were all taken with a correction table loaded into the analyzer. The correction table was used to account for the losses of the cables and attenuators used as part of the system to connect the EUT to the analyzer at all frequencies of interest.
- 2) All modes of operation and data rates were investigated. For radiated emission test, every axis (X, Y, Z) was also verified. The test results shown in the following sections represent the worst case emissions.

5.2. 6dB Bandwidth Measurement

5.2.1. Test Limit

The minimum 6dB bandwidth shall be at least 500 kHz.

5.2.2. Test Procedure used

ANSI C63.10-2013 - Section 11.8

5.2.3. Test Setting

1. The Spectrum's automatic bandwidth measurement capability was used to perform the 6dB bandwidth measurement. The "X" dB bandwidth parameter was set to $X = 6$. The bandwidth measurement was not influenced by any intermediate power nulls in the fundamental emission.
2. Set RBW = 100 kHz
3. VBW $\geq 3 \times$ RBW
4. Detector = Peak
5. Trace mode = Max hold
6. Sweep = Auto couple
7. Allow the trace was allowed to stabilize

5.2.4. Test Setup

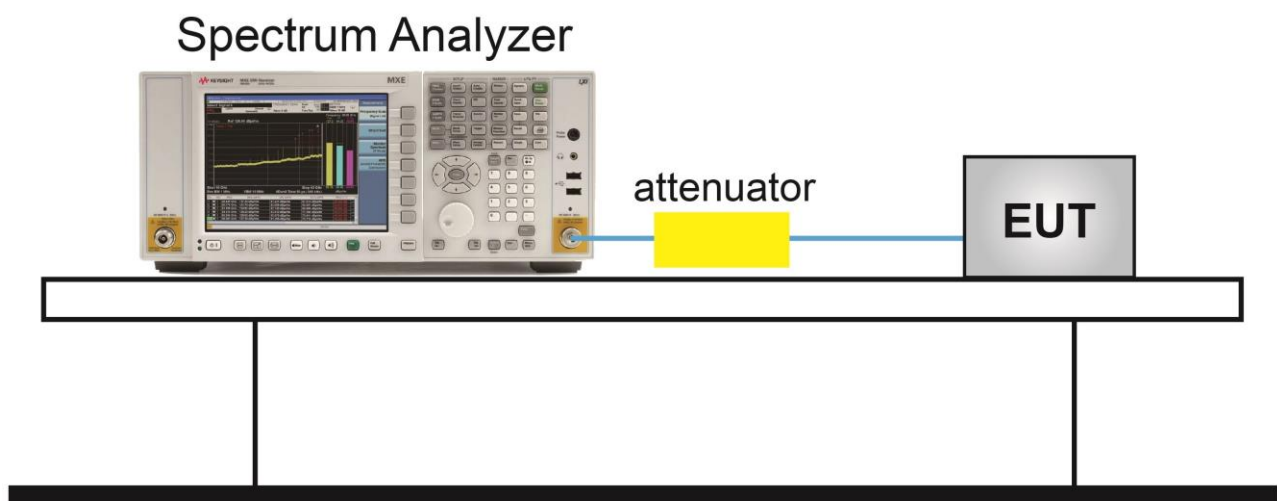

5.2.5. Test Result

Test Site	SIP-TR1	Test Engineer	Alisa Deng
Test Date	2021/06/25		

Test Mode	Data Rate (Mbps)	Channel No.	Frequency (MHz)	6dB Bandwidth (MHz)	Limit (MHz)	Result
BLE	1	00	2402	0.72	≥ 0.5	Pass
BLE	1	19	2440	0.72	≥ 0.5	Pass
BLE	1	39	2480	0.71	≥ 0.5	Pass
BLE	2	00	2402	1.26	≥ 0.5	Pass
BLE	2	19	2440	1.26	≥ 0.5	Pass
BLE	2	39	2480	1.26	≥ 0.5	Pass

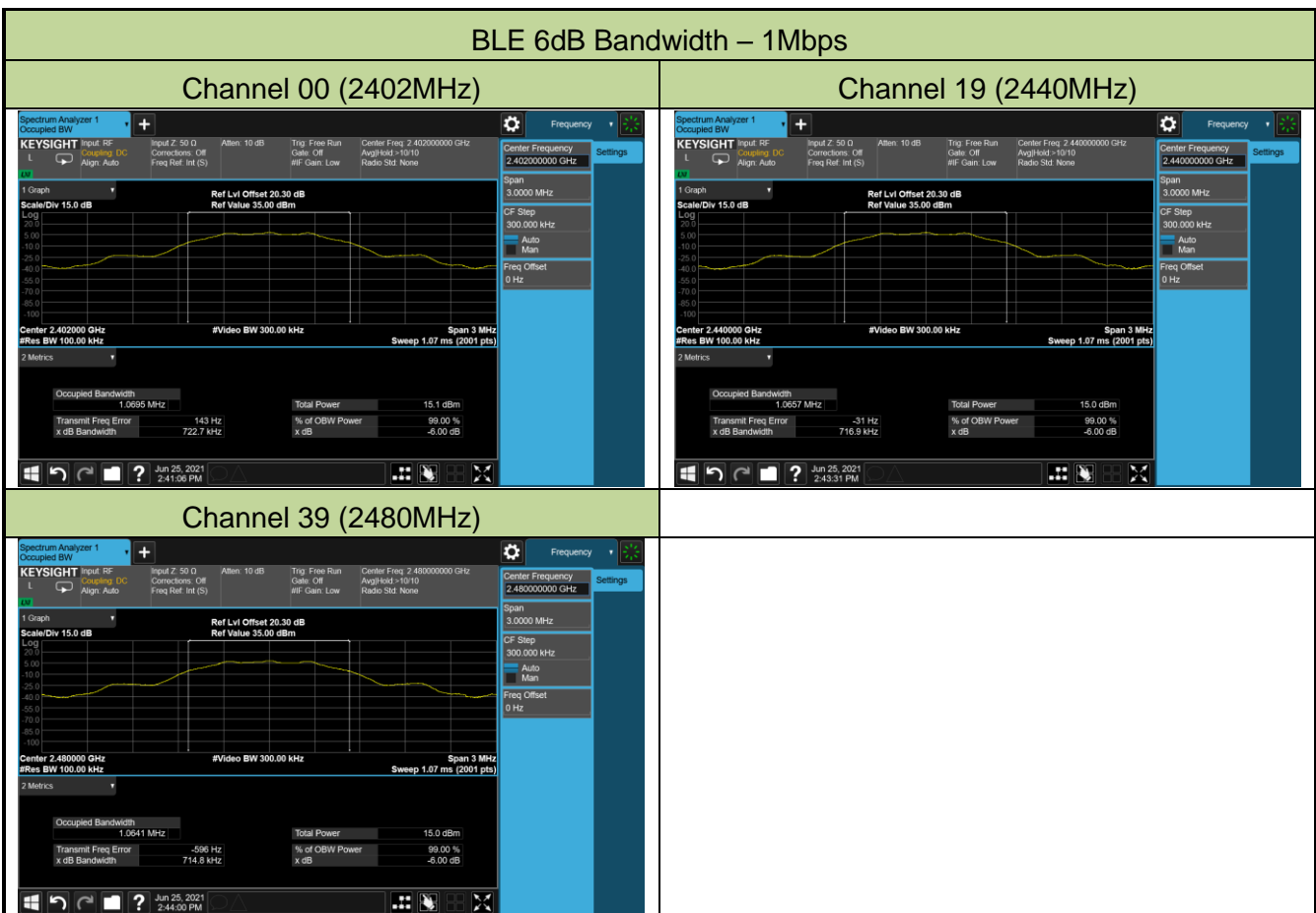

BLE 6dB Bandwidth – 2Mbps

Channel 00 (2402MHz)



Channel 19 (2440MHz)

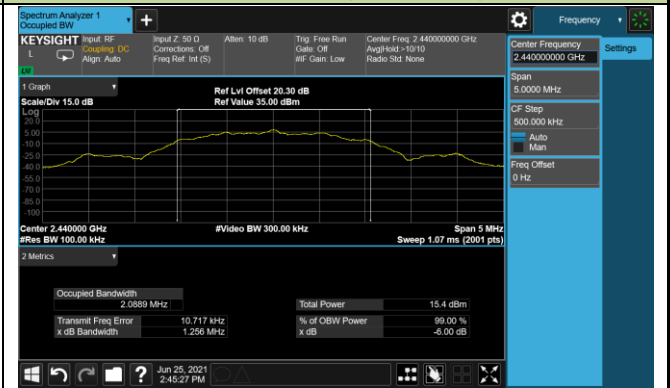

Channel 39 (2480MHz)

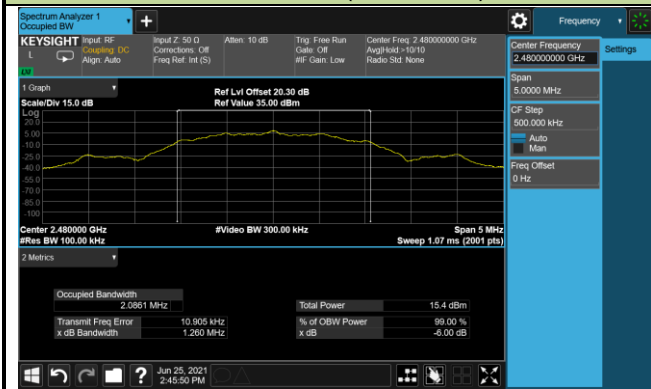

5.3. Output Power Measurement

5.3.1. Test Limit

The maximum output power shall be less 1 Watt (30dBm).

5.3.2. Test Procedure Used

ANSI C63.10-2013 - Section 11.9.1.3

ANSI C63.10-2013 - Section 11.9.2.3.2

5.3.3. Test Setting

Method PKPM1 (Peak Power Measurement)

Peak power measurements were performed only when the EUT was transmitting at its maximum power control level using a broadband power meter with a pulse sensor. The pulse sensor employs a VBW = 50MHz so this method was only used for signals whose DTS bandwidth was less than or equal to 50MHz.

Method AVGPM-G (Measurement using a gated RF average-reading power meter)

Measurements may be performed using a wideband gated RF power meter provided that the gate parameters are adjusted such that the power is measured only when the EUT is transmitting at its maximum power control level. Since this measurement is made only during the ON time of the transmitter, no duty cycle correction is required.

5.3.4. Test Setup

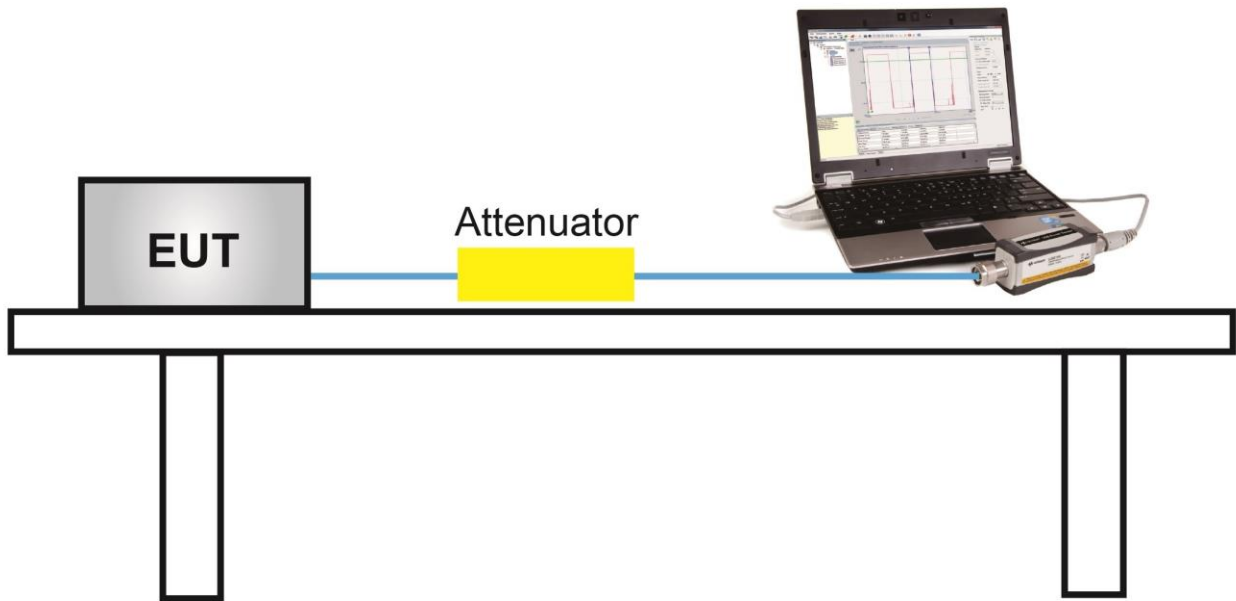

5.3.5. Test Result

Test Site	SIP-TR1	Test Engineer	Alisa Deng
Test Date	2021/06/22		

Test Result of Peak Output Power

Test Mode	Data Rate (Mbps)	Channel No.	Frequency (MHz)	Peak Power (dBm)	Limit (dBm)	Result
BLE	1	00	2402	10.30	≤ 30.00	Pass
BLE	1	19	2440	10.24	≤ 30.00	Pass
BLE	1	39	2480	10.25	≤ 30.00	Pass
BLE	2	00	2402	10.28	≤ 30.00	Pass
BLE	2	19	2440	10.25	≤ 30.00	Pass
BLE	2	39	2480	10.27	≤ 30.00	Pass

Test Result of Average Output Power (Reporting Only)

Test Mode	Data Rate (Mbps)	Channel No.	Frequency (MHz)	Average Power (dBm)	Limit (dBm)	Result
BLE	1	00	2402	9.71	≤ 30.00	Pass
BLE	1	19	2440	9.70	≤ 30.00	Pass
BLE	1	39	2480	9.72	≤ 30.00	Pass
BLE	2	00	2402	9.70	≤ 30.00	Pass
BLE	2	19	2440	9.71	≤ 30.00	Pass
BLE	2	39	2480	9.73	≤ 30.00	Pass

5.4. Power Spectral Density Measurement

5.4.1. Test Limit

The maximum permissible power spectral density is 8dBm in any 3 kHz band.

The same method of determining the conducted output power shall be used to determine the power spectral density.

5.4.2. Test Procedure Used

ANSI C63.10-2013 - Section 11.10.2

5.4.3. Test Setting

1. Analyzer was set to the center frequency of the DTS channel under investigation
2. Span = 1.5 times the OBW
3. RBW = 3kHz
4. VBW = 10kHz
5. Detector = Peak
6. Sweep time = Auto couple
7. Trace mode = Max hold
8. Trace was allowed to stabilize

5.4.4. Test Setup

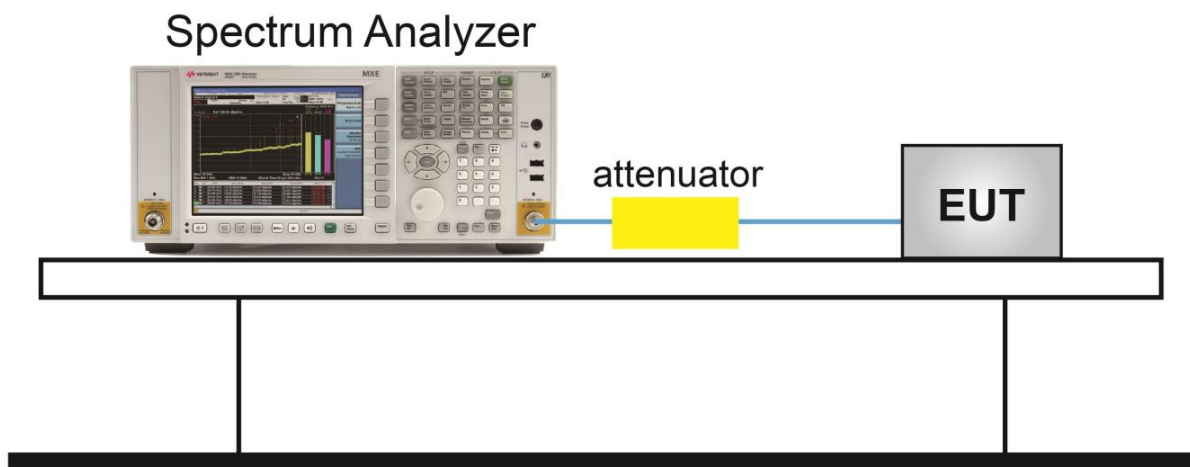

5.4.5. Test Result

Test Site	SIP-TR1	Test Engineer	Alisa Deng
Test Date	2021/06/21		

Test Mode	Data Rate (Mbps)	Channel No.	Frequency (MHz)	PSD Result (dBm / 3kHz)	Limit (dBm / 3kHz)	Result
BLE	1	00	2402	-4.97	≤ 8.00	Pass
BLE	1	19	2440	-5.06	≤ 8.00	Pass
BLE	1	39	2480	-5.02	≤ 8.00	Pass
BLE	2	00	2402	-7.97	≤ 8.00	Pass
BLE	2	19	2440	-7.94	≤ 8.00	Pass
BLE	2	39	2480	-7.83	≤ 8.00	Pass

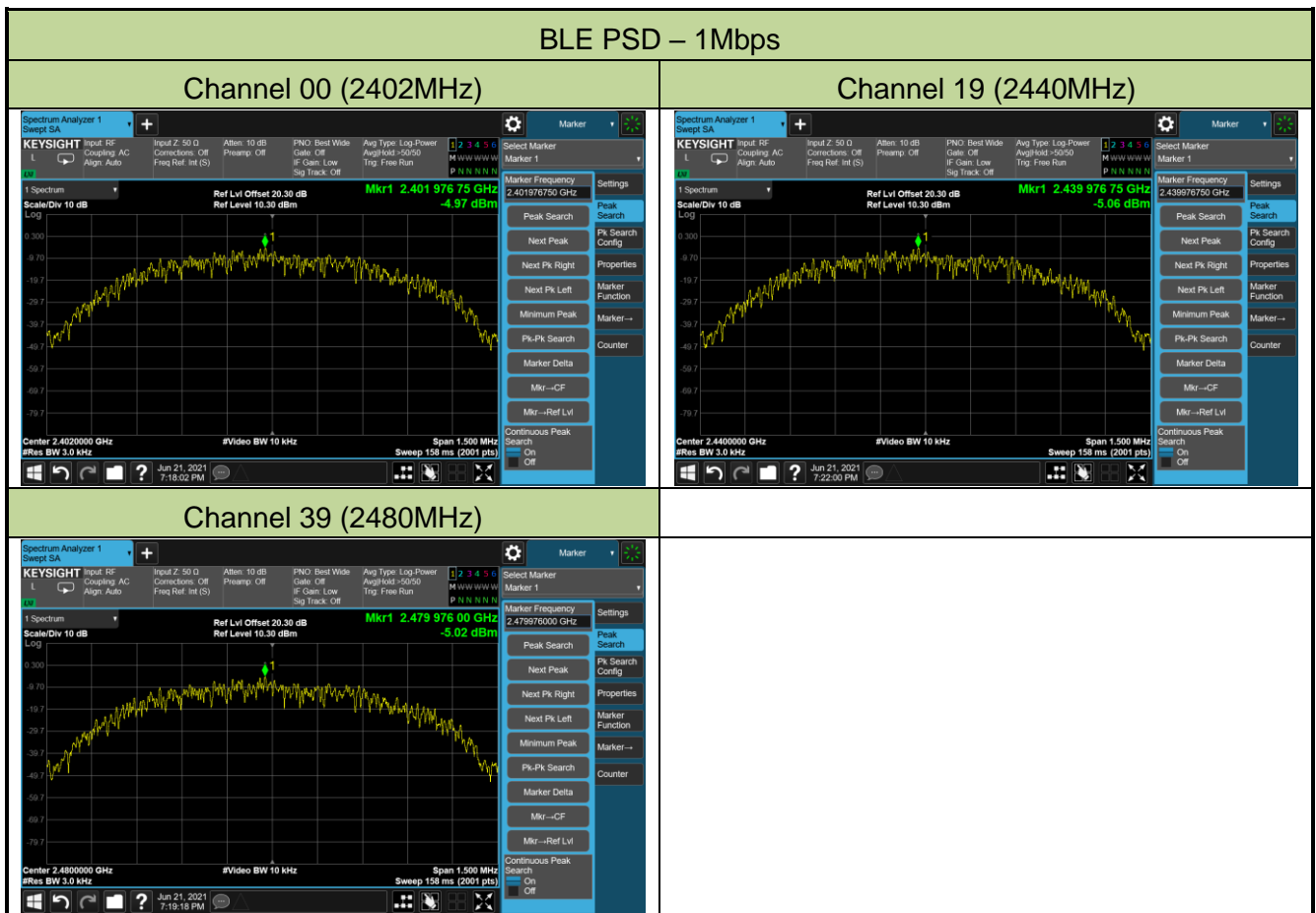

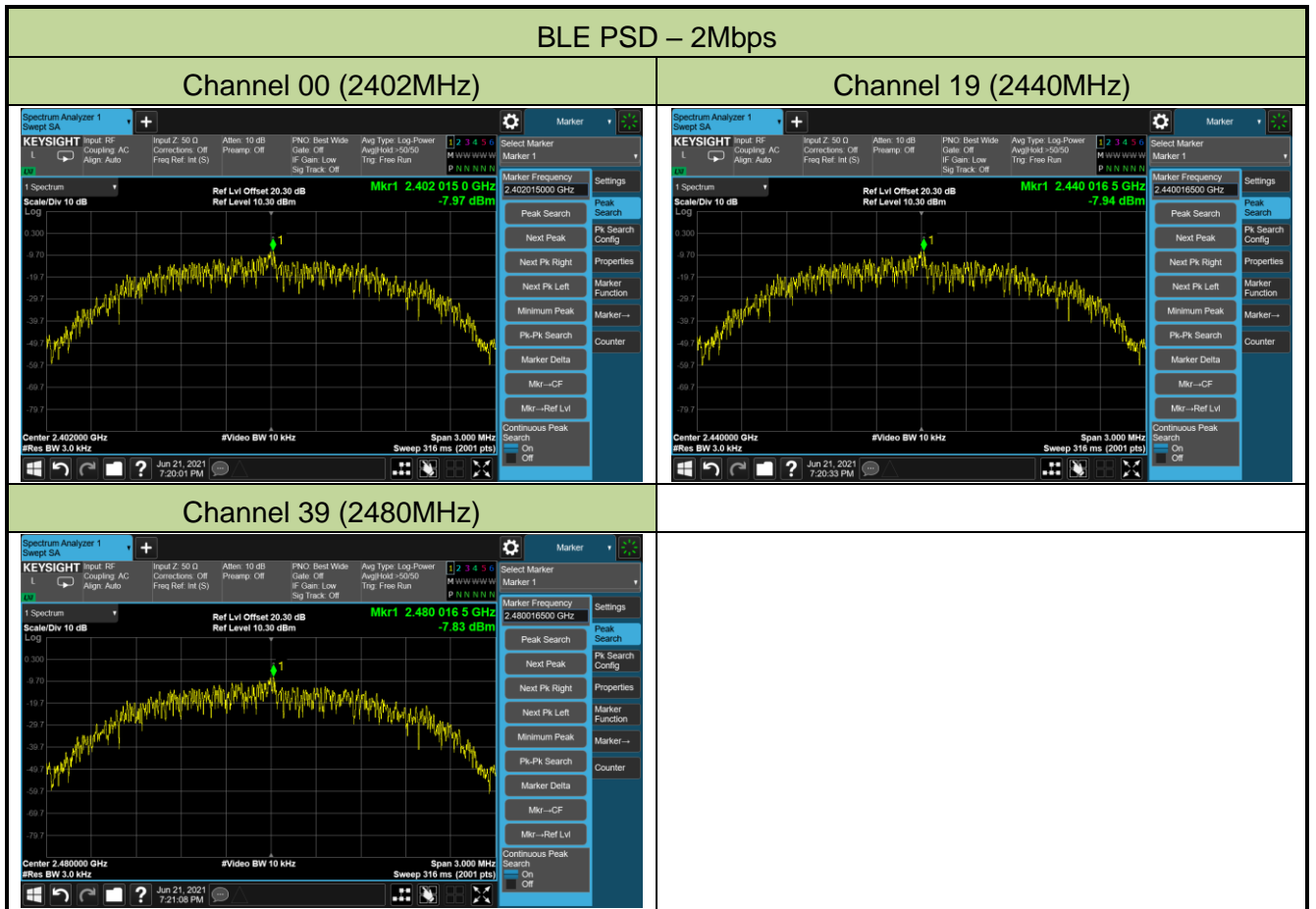

5.5. Conducted Band Edge and Out-of-Band Emissions

5.5.1. Test Limit

The limit for out-of-band spurious emissions at the band edge is 20dB below the fundamental emission level, as determined from the in-band power measurement of the DTS channel performed in a 100kHz bandwidth per the PSD procedure.

5.5.2. Test Procedure Used

ANSI C63.10-2013 - Section 11.11

5.5.3. Test Setting

Reference level measurement

1. Set instrument center frequency to DTS channel center frequency
2. Set the span to ≥ 1.5 times the DTS bandwidth
3. Set the RBW = 100 kHz
4. Set the VBW $\geq 3 \times$ RBW
5. Detector = Peak
6. Sweep time = Auto couple
7. Trace mode = Max hold
8. Allow trace to fully stabilize

Emission level measurement

1. Set the center frequency and span to encompass frequency range to be measured
2. RBW = 100kHz
3. VBW = 300kHz
4. Detector = Peak
5. Trace mode = Max hold
6. Sweep time = Auto couple
7. The trace was allowed to stabilize

5.5.4. Test Setup

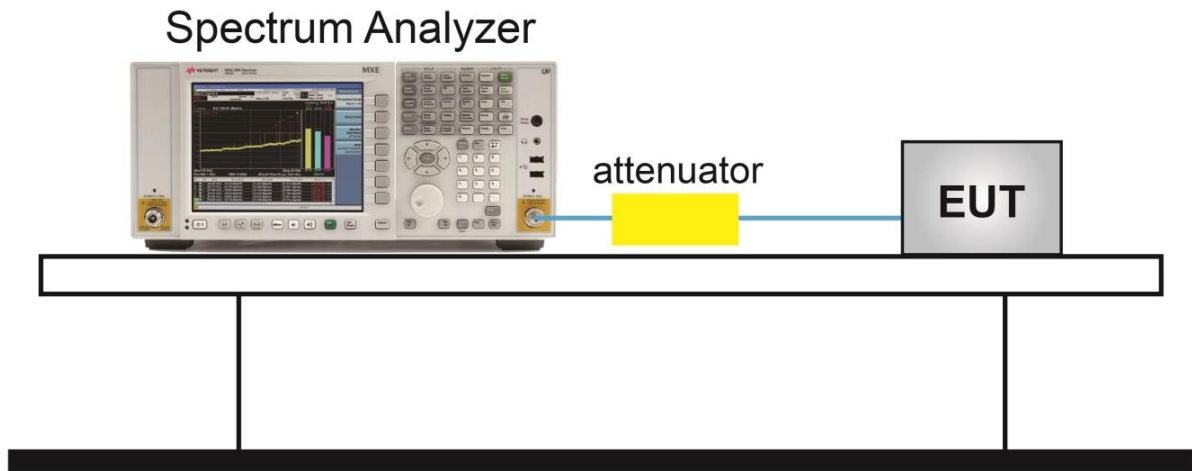

5.5.5. Test Result

Test Site	SIP-TR1	Test Engineer	Alisa Deng
Test Date	2021/06/21		

Test Mode	Data Rate (Mbps)	Channel No.	Frequency (MHz)	Limit	Result
BLE	1	00	2402	20dBc	Pass
BLE	1	19	2440	20dBc	Pass
BLE	1	39	2480	20dBc	Pass
BLE	2	00	2402	20dBc	Pass
BLE	2	19	2440	20dBc	Pass
BLE	2	39	2480	20dBc	Pass

BLE Out-of-Band Emissions – 1Mbps

Channel 00 (2402MHz)

100kHz PSD reference Level

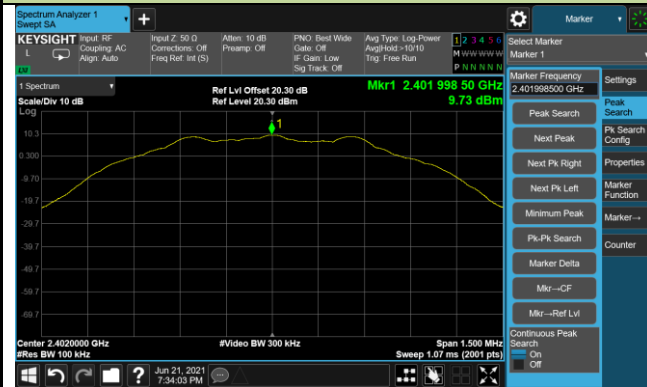

Low Band Edge



Spurious Emission 30MHz ~ 25GHz

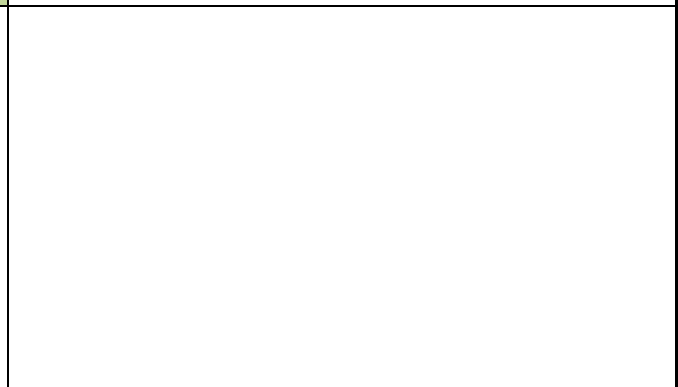

Channel 19 (2440MHz)

100kHz PSD reference Level

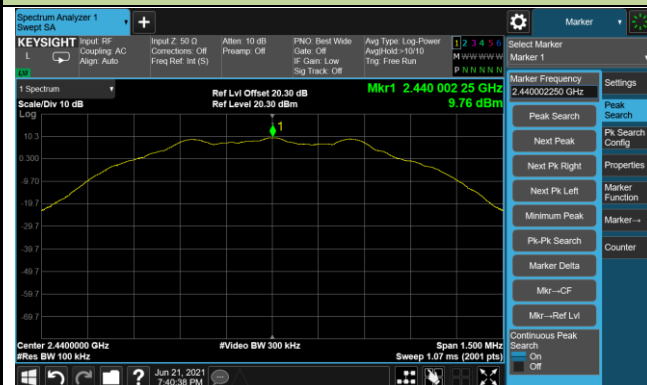

Spurious Emission 30MHz ~ 25GHz



Channel 39 (2480MHz)

100kHz PSD reference Level

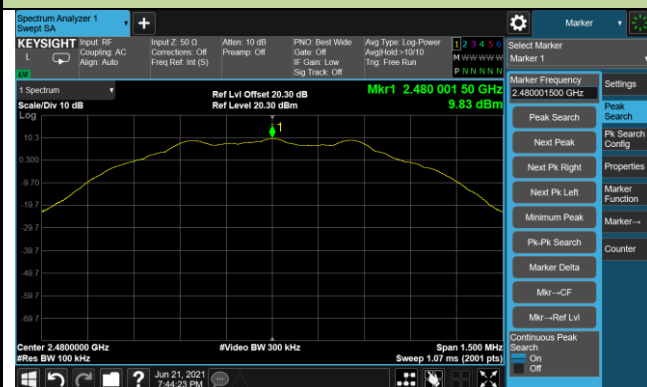

High Band Edge

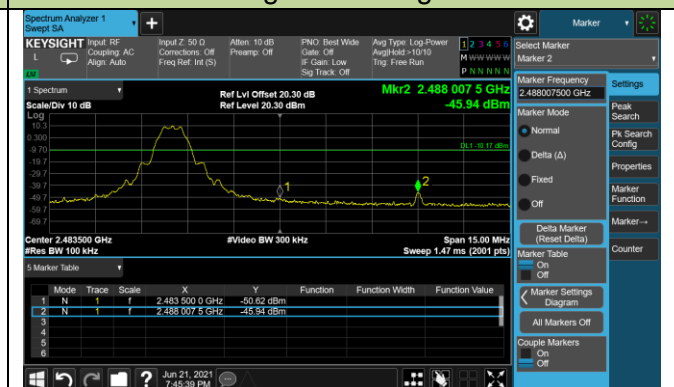

Spurious Emission 30MHz ~ 25GHz

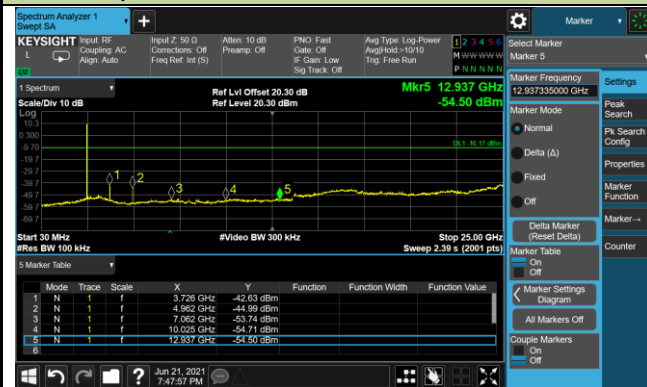

BLE Out-of-Band Emissions – 2Mbps

Channel 00 (2402MHz)

100kHz PSD reference Level



Low Band Edge



Spurious Emission 30MHz ~ 25GHz

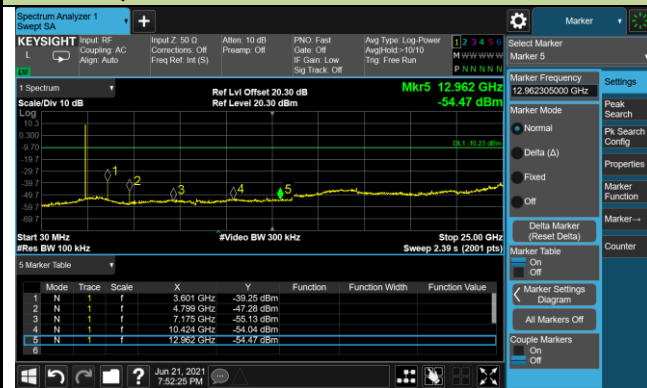

Channel 19 (2440MHz)

100kHz PSD reference Level

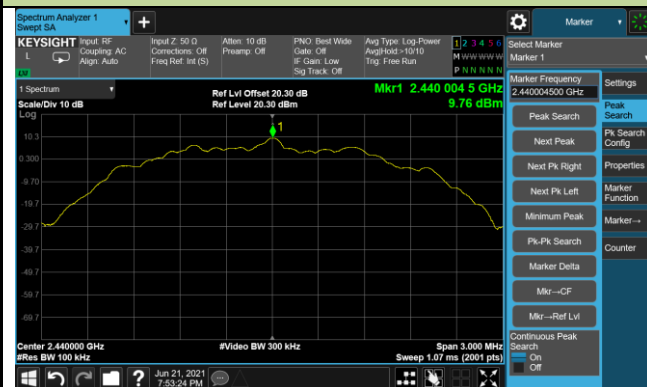

Spurious Emission 30MHz ~ 25GHz



Channel 39 (2480MHz)

100kHz PSD reference Level



High Band Edge



Spurious Emission 30MHz ~ 25GHz



5.6. Radiated Spurious Emission Measurement

5.6.1. Test Limit

All out of band emissions appearing in a restricted band as specified in Section 15.205 of the Title 47 CFR must not exceed the limits shown in Table per Section 15.209.

FCC Part 15 Subpart C Paragraph 15.209		
Frequency (MHz)	Field Strength ($\mu\text{V}/\text{m}$)	Measured Distance (m)
0.009 - 0.490	2400/F (kHz)	300
0.490 - 1.705	24000/F (kHz)	30
1.705 - 30	30	30
30 - 88	100	3
88 - 216	150	3
216 - 960	200	3
Above 960	500	3

5.6.2. Test Procedure Used

ANSI C63.10-2013 - Section 6.3 & 6.4 & 6.5 & 6.6

5.6.3. Test Setting

Table 1 - RBW as a function of frequency

Frequency	RBW
9 ~ 150 kHz	200 ~ 300 Hz
0.15 ~ 30 MHz	9 ~ 10 kHz
30 ~ 1000 MHz	100 ~ 120 kHz
> 1000 MHz	1 MHz

Quasi-Peak Measurements below 1GHz

1. Analyzer center frequency was set to the frequency of the radiated spurious emission of interest
2. Span was set greater than 1MHz
3. RBW = as specified in Table 1
4. Detector = CISPR quasi-peak
5. Sweep time = auto couple
6. Trace was allowed to stabilize

Peak Measurements above 1GHz

1. Analyzer center frequency was set to the frequency of the radiated spurious emission of interest
2. RBW = 1MHz
3. VBW = 3MHz
4. Detector = peak
5. Sweep time = auto couple
6. Trace mode = max hold
7. Trace was allowed to stabilize

Average Measurements above 1GHz (Method VB)

1. Analyzer center frequency was set to the frequency of the radiated spurious emission of interest
2. RBW = 1MHz
3. VBW; If the EUT is configured to transmit with duty cycle $\geq 98\%$, set VBW = 10Hz
If the EUT duty cycle is $< 98\%$, set VBW $\geq 1/T$. T is the minimum transmission duration
4. Detector = Peak
5. Sweep time = auto
6. Trace mode = max hold
7. Trace was allowed to stabilize

5.6.4. Test Setup

Below 1GHz Test Setup:

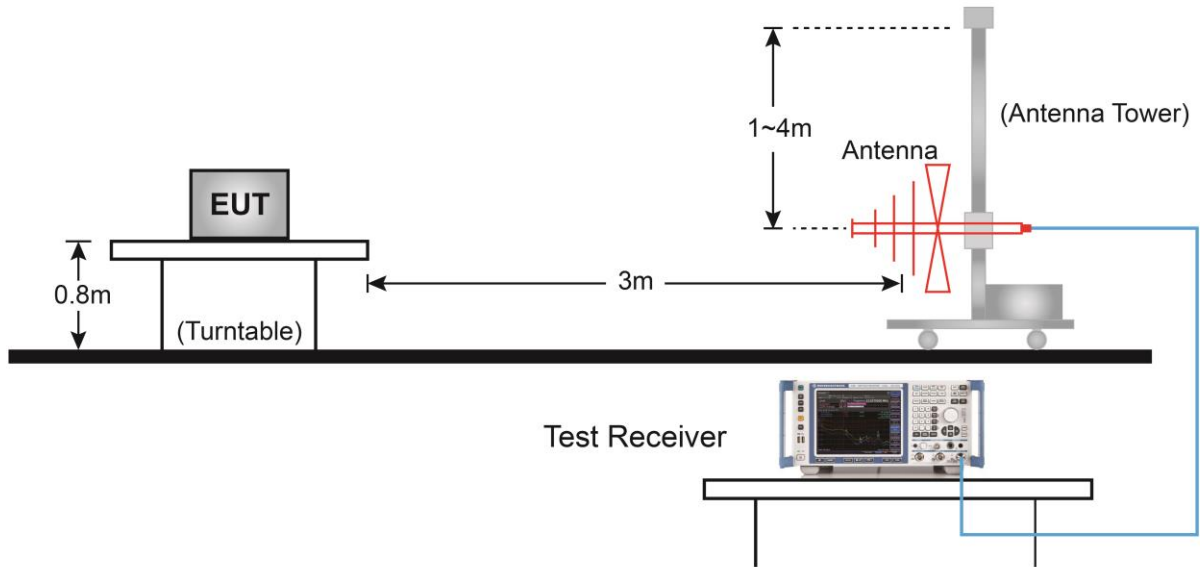

Above 1GHz Test Setup:

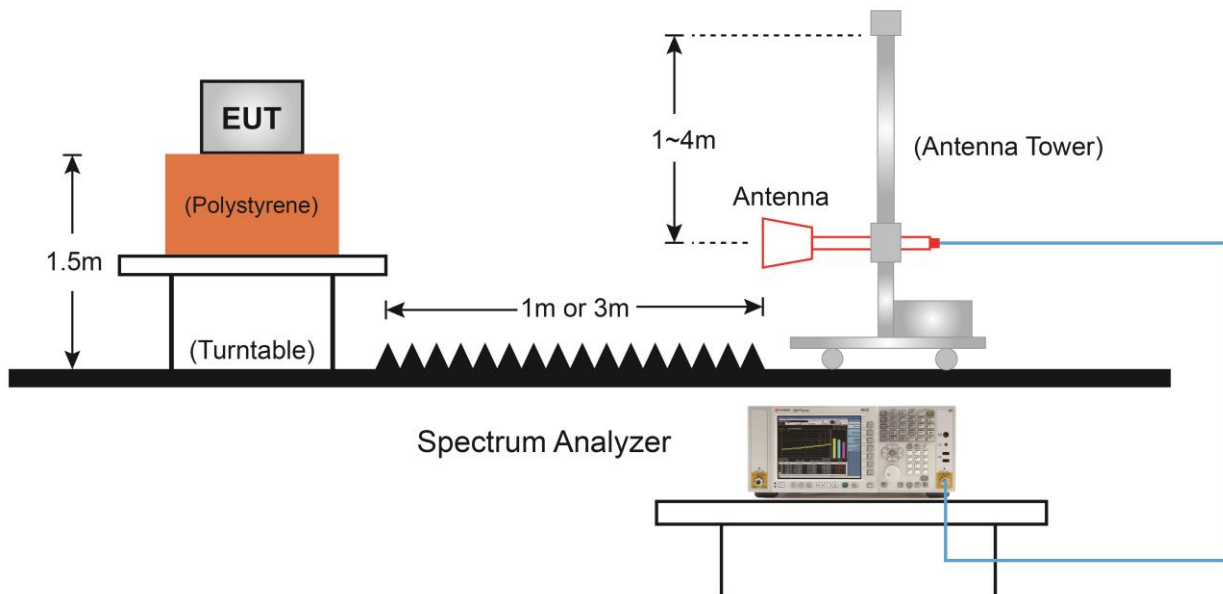

5.6.5. Test Result

Test Site	SIP-AC2	Test Engineer	Stephen Dong
Test Mode	BLE - 1Mbps	Test Date	2021/06/20
Test Channel	00		
Remark	1. Average measurement was not performed if peak level lower than average limit. 2. Other frequency was 20dB below limit line within 1-18GHz, there is not show in the report.		

Frequency (MHz)	Reading Level (dB μ V)	Factor (dB)	Measure Level (dB μ V/m)	Limit (dB μ V/m)	Margin (dB)	Detector	Polarization
10809.0	45.6	4.4	50.0	74.0	-24.0	Peak	Horizontal
11548.5	45.3	5.3	50.6	74.0	-23.4	Peak	Horizontal
12084.0	45.1	4.6	49.7	74.0	-24.3	Peak	Horizontal
10885.5	45.5	4.7	50.2	74.0	-23.8	Peak	Vertical
11531.5	44.7	5.5	50.2	74.0	-23.8	Peak	Vertical
12177.5	45.1	4.5	49.6	74.0	-24.4	Peak	Vertical

Note: Measure Level (dB μ V/m) = Reading Level (dB μ V) + Factor (dB)

Factor (dB) = Cable Loss (dB) + Antenna Factor (dB/m) - Pre_Amplifier Gain (dB)

Test Site	SIP-AC2	Test Engineer	Stephen Dong
Test Mode	BLE - 1Mbps	Test Date	2021/06/20
Test Channel	19		
Remark	1. Average measurement was not performed if peak level lower than average limit. 2. Other frequency was 20dB below limit line within 1-18GHz, there is not show in the report.		

Frequency (MHz)	Reading Level (dB μ V)	Factor (dB)	Measure Level (dB μ V/m)	Limit (dB μ V/m)	Margin (dB)	Detector	Polarization
7324.0	54.0	-1.7	52.3	74.0	-21.7	Peak	Horizontal
10970.5	46.0	5.0	51.0	74.0	-23.0	Peak	Horizontal
11438.0	45.3	5.5	50.8	74.0	-23.2	Peak	Horizontal
7315.5	52.2	-1.7	50.5	74.0	-23.5	Peak	Vertical
11047.0	46.9	5.7	52.6	74.0	-21.4	Peak	Vertical
11608.0	45.1	5.1	50.2	74.0	-23.8	Peak	Vertical

Note: Measure Level (dB μ V/m) = Reading Level (dB μ V) + Factor (dB)

Factor (dB) = Cable Loss (dB) + Antenna Factor (dB/m) - Pre_Amplifier Gain (dB)

Test Site	SIP-AC2	Test Engineer	Stephen Dong
Test Mode	BLE - 1Mbps	Test Date	2021/06/20
Test Channel	39		
Remark	1. Average measurement was not performed if peak level lower than average limit. 2. Other frequency was 20dB below limit line within 1-18GHz, there is not show in the report.		

Frequency (MHz)	Reading Level (dBμV)	Factor (dB)	Measure Level (dBμV/m)	Limit (dBμV/m)	Margin (dB)	Detector	Polarization
7443.0	52.9	-1.1	51.8	74.0	-22.2	Peak	Horizontal
10911.0	45.8	4.7	50.5	74.0	-23.5	Peak	Horizontal
11344.5	46.3	5.0	51.3	74.0	-22.7	Peak	Horizontal
7443.0	50.7	-1.1	49.6	74.0	-24.4	Peak	Vertical
11081.0	45.2	5.1	50.3	74.0	-23.7	Peak	Vertical
11540.0	45.7	5.4	51.1	74.0	-22.9	Peak	Vertical

Note: Measure Level (dBμV/m) = Reading Level (dBμV) + Factor (dB)

Factor (dB) = Cable Loss (dB) + Antenna Factor (dB/m) - Pre_Amplifier Gain (dB)

Test Site	SIP-AC2	Test Engineer	Stephen Dong
Test Mode	BLE - 2Mbps	Test Date	2021/06/20
Test Channel	00		
Remark	1. Average measurement was not performed if peak level lower than average limit. 2. Other frequency was 20dB below limit line within 1-18GHz, there is not show in the report.		

Frequency (MHz)	Reading Level (dB μ V)	Factor (dB)	Measure Level (dB μ V/m)	Limit (dB μ V/m)	Margin (dB)	Detector	Polarization
10647.5	46.4	3.8	50.2	74.0	-23.8	Peak	Horizontal
11616.5	45.7	5.1	50.8	74.0	-23.2	Peak	Horizontal
12254.0	45.1	4.4	49.5	74.0	-24.5	Peak	Horizontal
7451.5	48.7	-1.1	47.6	74.0	-26.4	Peak	Vertical
11234.0	46.4	4.9	51.3	74.0	-22.7	Peak	Vertical
11965.0	45.1	4.2	49.3	74.0	-24.7	Peak	Vertical

Note: Measure Level (dB μ V/m) = Reading Level (dB μ V) + Factor (dB)

Factor (dB) = Cable Loss (dB) + Antenna Factor (dB/m) - Pre_Amplifier Gain (dB)

Test Site	SIP-AC2	Test Engineer	Stephen Dong
Test Mode	BLE - 2Mbps	Test Date	2021/06/20
Test Channel	19		
Remark	1. Average measurement was not performed if peak level lower than average limit. 2. Other frequency was 20dB below limit line within 1-18GHz, there is not show in the report.		

Frequency (MHz)	Reading Level (dB μ V)	Factor (dB)	Measure Level (dB μ V/m)	Limit (dB μ V/m)	Margin (dB)	Detector	Polarization
7315.5	53.5	-1.7	51.8	74.0	-22.2	Peak	Horizontal
11285.0	46.5	5.1	51.6	74.0	-22.4	Peak	Horizontal
12169.0	45.4	4.6	50.0	74.0	-24.0	Peak	Horizontal
7315.5	52.0	-1.7	50.3	74.0	-23.7	Peak	Vertical
10758.0	46.1	4.0	50.1	74.0	-23.9	Peak	Vertical
11404.0	45.1	5.1	50.2	74.0	-23.8	Peak	Vertical

Note: Measure Level (dB μ V/m) = Reading Level (dB μ V) + Factor (dB)

Factor (dB) = Cable Loss (dB) + Antenna Factor (dB/m) - Pre_Amplifier Gain (dB)

Test Site	SIP-AC2	Test Engineer	Stephen Dong
Test Mode	BLE - 2Mbps	Test Date	2021/06/20
Test Channel	39		
Remark	1. Average measurement was not performed if peak level lower than average limit. 2. Other frequency was 20dB below limit line within 1-18GHz, there is not show in the report.		

Frequency (MHz)	Reading Level (dB μ V)	Factor (dB)	Measure Level (dB μ V/m)	Limit (dB μ V/m)	Margin (dB)	Detector	Polarization
7434.5	51.7	-1.1	50.6	74.0	-23.4	Peak	Horizontal
10860.0	44.9	4.9	49.8	74.0	-24.2	Peak	Horizontal
11429.5	44.6	5.5	50.1	74.0	-23.9	Peak	Horizontal
10860.0	45.8	4.9	50.7	74.0	-23.3	Peak	Vertical
11370.0	45.9	4.9	50.8	74.0	-23.2	Peak	Vertical
12160.5	44.7	4.5	49.2	74.0	-24.8	Peak	Vertical

Note: Measure Level (dB μ V/m) = Reading Level (dB μ V) + Factor (dB)

Factor (dB) = Cable Loss (dB) + Antenna Factor (dB/m) - Pre_Amplifier Gain (dB)

The Result of Radiated Emission below 1GHz:

Site: SIP-AC1	Time: 2021/06/20
Limit: FCC_Part15.209_RE(3m)_Class B	Engineer: Mero Zhou
Probe: SIP-AC1_VULB 9168 _30-1000MHz	Polarity: Horizontal
EUT: True Wireless Earphone	Power: Powered by Battery
Worst Case Mode: Transmit by BLE at Channel 2402MHz	

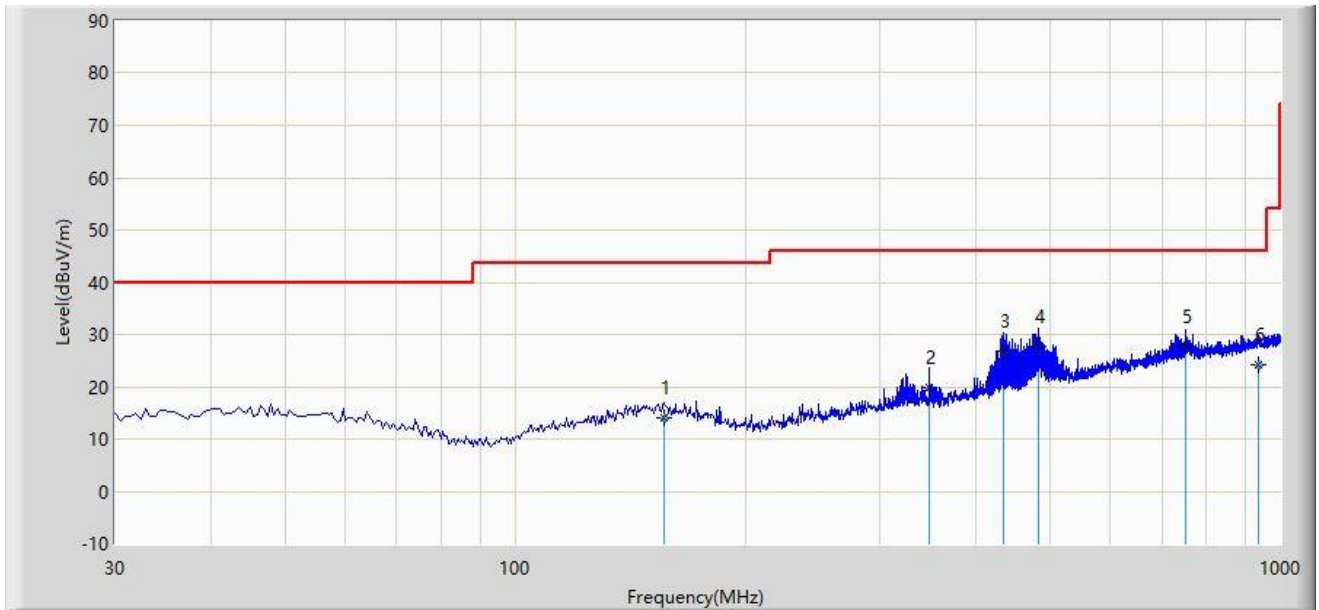

No	Flag	Mark	Frequency (MHz)	Measure Level (dBuV/m)	Reading Level (dBuV)	Margin (dB)	Limit (dBuV/m)	Factor (dB)	Type
1			156.585	13.945	-4.100	-29.555	43.500	18.045	QP
2			348.160	19.713	0.500	-26.287	46.000	19.213	QP
3			434.005	26.890	5.160	-19.110	46.000	21.730	QP
4			482.020	27.661	5.220	-18.339	46.000	22.441	QP
5		*	752.165	27.749	0.150	-18.251	46.000	27.599	QP
6			936.465	24.226	-4.900	-21.774	46.000	29.126	QP

Note 1: Measure Level (dB μ V/m) = Reading Level (dB μ V) + Factor (dB)

Factor (dB) = Cable Loss (dB) + Antenna Factor (dB/m)

Note 2: The amplitude of radiated emissions (frequency range from 9kHz to 30MHz and 18GHz to 25GHz) is that proximity to ambient noise, which also are attenuated more than 20 dB below the permissible value.

Therefore, the data is not presented in the report.

Site: SIP-AC1	Time: 2021/06/20
Limit: FCC_Part15.209_RE(3m)_Class B	Engineer: Mero Zhou
Probe: SIP-AC1_VULB 9168 _30-1000MHz	Polarity: Vertical
EUT: True Wireless Earphone	Power: Powered by Battery
Worst Case Mode: Transmit by BLE at Channel 2402MHz	

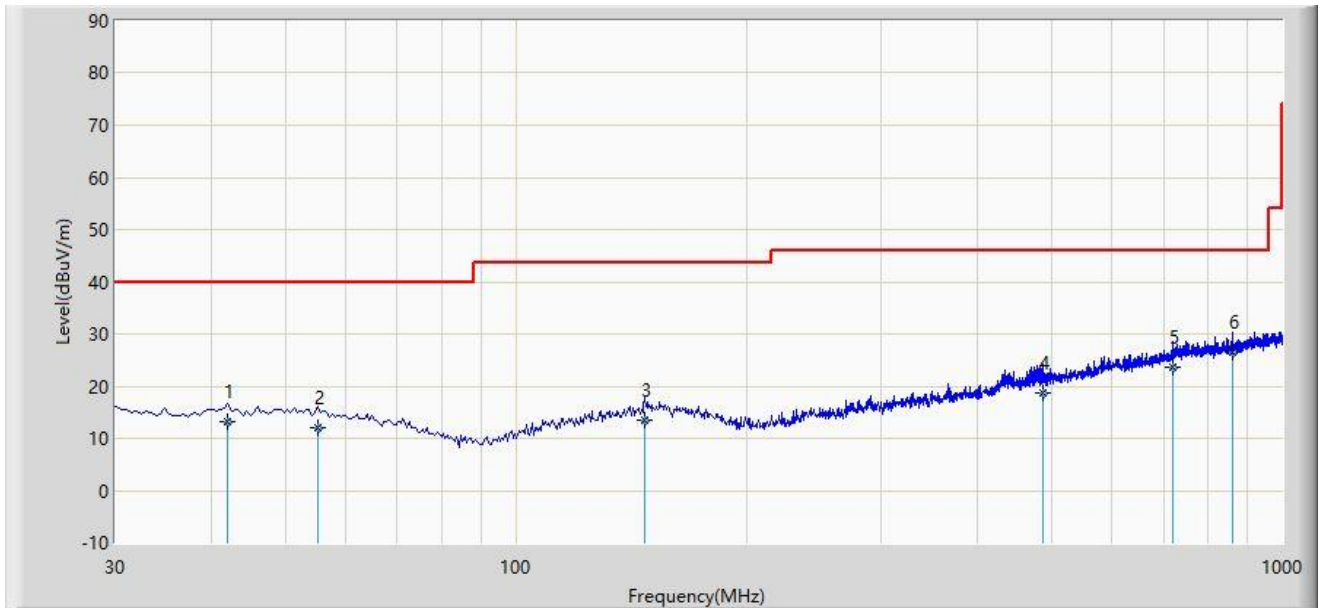

No	Flag	Mark	Frequency (MHz)	Measure Level (dBuV/m)	Reading Level (dBuV)	Margin (dB)	Limit (dBuV/m)	Factor (dB)	Type
1			42.125	13.125	-4.520	-26.875	40.000	17.644	QP
2			55.220	12.066	-5.320	-27.934	40.000	17.386	QP
3			147.370	13.351	-4.620	-30.149	43.500	17.971	QP
4			487.840	18.832	-3.640	-27.168	46.000	22.472	QP
5			719.185	23.691	-2.950	-22.309	46.000	26.641	QP
6		*	862.260	26.447	-1.750	-19.553	46.000	28.197	QP

Note 1: Measure Level (dBuV/m) = Reading Level (dBuV) + Factor (dB)

Factor (dB) = Cable Loss (dB) + Antenna Factor (dB/m)

Note 2: The amplitude of radiated emissions (frequency range from 9kHz to 30MHz and 18GHz to 25GHz) is that proximity to ambient noise, which also are attenuated more than 20 dB below the permissible value.

Therefore, the data is not presented in the report.

5.7. Radiated Restricted Band Edge Measurement

5.7.1. Test Limit

For 15.205 requirement:

Radiated emissions which fall in the restricted bands, as defined in Section 15.205(a) of FCC part 15, must also comply with the radiated emission limits specified in Section 15.209(a).

Frequency (MHz)	Frequency (MHz)	Frequency (MHz)	Frequency (GHz)
0.090 - 0.110	16.42 - 16.423	399.9 - 410	4.5 - 5.15
¹ 0.495 - 0.505	16.69475 - 16.69525	608 - 614	5.35 - 5.46
2.1735 - 2.1905	16.80425 - 16.80475	960 - 1240	7.25 - 7.75
4.125 - 4.128	25.5 - 25.67	1300 - 1427	8.025 - 8.5
4.17725 - 4.17775	37.5 - 38.25	1435 - 1626.5	9.0 - 9.2
4.20725 - 4.20775	73 - 74.6	1645.5 - 1646.5	9.3 - 9.5
6.215 - 6.218	74.8 - 75.2	1660 - 1710	10.6 - 12.7
6.26775 - 6.26825	108 - 121.94	1718.8 - 1722.2	13.25 - 13.4
6.31175 - 6.31225	123 - 138	2200 - 2300	14.47 - 14.5
8.291 - 8.294	149.9 - 150.05	2310 - 2390	15.35 - 16.2
8.362 - 8.366	156.52475 - 156.52525	2483.5 - 2500	17.7 - 21.4
8.37625 - 8.38675	156.7 - 156.9	2690 - 2900	22.01 - 23.12
8.41425 - 8.41475	162.0125 - 167.17	3260 - 3267	23.6 - 24.0
12.29 - 12.293	167.72 - 173.2	3332 - 3339	31.2 - 31.8
12.51975 - 12.52025	240 - 285	3345.8 - 3358	36.43 - 36.5
12.57675 - 12.57725	322 - 335.4	3600 - 4400	(²)
13.36 - 13.41	--	--	--

All out of band emissions appearing in a restricted band as specified in Section 15.205 of the Title 47 CFR must not exceed the limits shown in Table per Section 15.209.

FCC Part 15 Subpart C Paragraph 15.209		
Frequency [MHz]	Field Strength [uV/m]	Measured Distance [Meters]
0.009 - 0.490	2400/F (kHz)	300
0.490 - 1.705	24000/F (kHz)	30
1.705 - 30	30	30
30 - 88	100	3
88 - 216	150	3
216 - 960	200	3
Above 960	500	3

5.7.2. Test Procedure Used

ANSI C63.10-2013 - Section 6.3 & 6.6 & 11.13

5.7.3. Test Setting

Peak Field Strength Measurements

1. Analyzer center frequency was set to the frequency of the radiated spurious emission of interest
2. RBW = 1MHz
3. VBW = 3MHz
4. Detector = peak
5. Sweep time = auto couple
6. Trace mode = max hold
7. Trace was allowed to stabilize

Average Field Strength Measurements

1. Analyzer center frequency was set to the frequency of the radiated spurious emission of interest
2. RBW = 1MHz
3. VBW $\geq 1/T$
4. De As an alternative, the instrument may be set to linear detector mode. Ensure that video filtering is applied in linear voltage domain (rather than in a log or dB domain). Some instruments require linear display mode in order to accomplish this. Others have a setting for Average-VBW Type, which can be set to "Voltage" regardless of the display mode
5. Detector = Peak
6. Sweep time = auto
7. Trace mode = max hold
8. Allow max hold to run for at least 50 times (1/duty cycle) traces

5.7.4. Test Setup

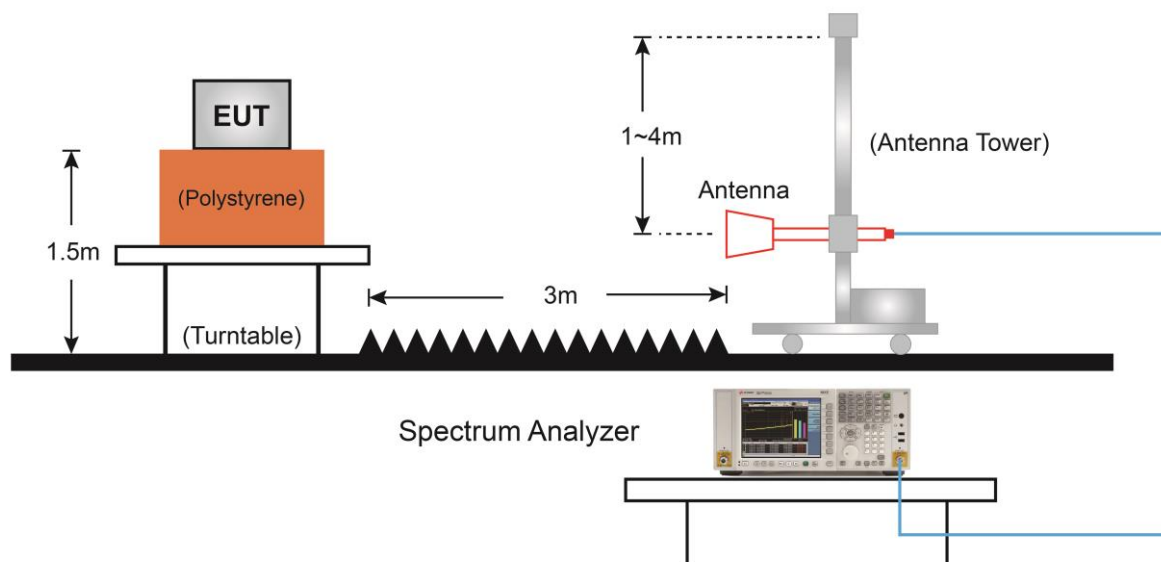

5.7.5. Test Result

Site: SIP-AC2	Time: 2021/06/20 - 14:24
Limit: FCC_Part15.209 RE(3m)	Engineer: Stephen Dong
Probe: SIP-AC2_BBHA9120D_1-18GHz	Polarity: Horizontal
EUT: True Wireless Earphone	Power: Powered by Battery
Note: Transmit by BLE 1Mbps at Channel 2402MHz	

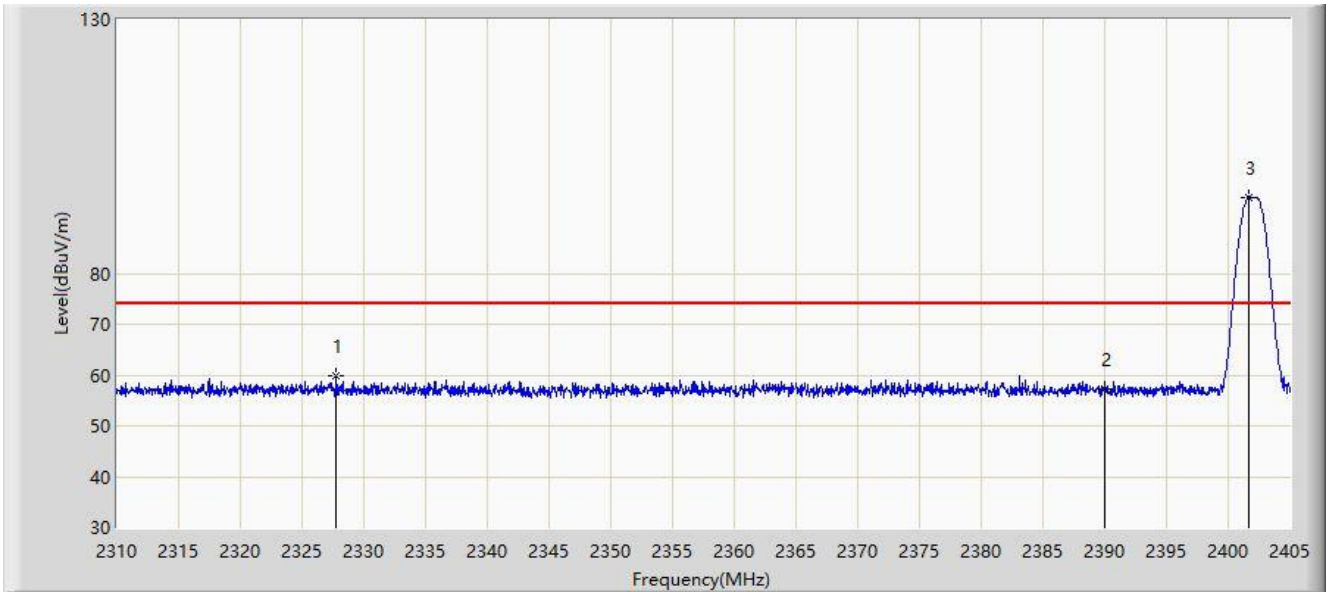

No	Flag	Mark	Frequency (MHz)	Measure Level (dBuV/m)	Reading Level (dBuV)	Margin (dB)	Limit (dBuV/m)	Factor (dB)	Type
1			2327.765	59.841	27.188	-14.159	74.000	32.653	PK
2			2390.000	57.293	24.889	-16.707	74.000	32.404	PK
3		*	2401.675	95.062	62.696	N/A	N/A	32.366	PK

Note: Measure Level (dB μ V/m) = Reading Level (dB μ V) + Factor (dB)

Factor (dB) = Cable Loss (dB) + Antenna Factor (dB/m)

Site: SIP-AC2	Time: 2021/06/20 - 14:35
Limit: FCC_Part15.209 RE(3m)	Engineer: Stephen Dong
Probe: SIP-AC2_BBHA9120D_1-18GHz	Polarity: Horizontal
EUT: True Wireless Earphone	Power: Powered by Battery
Note: Transmit by BLE 1Mbps at Channel 2402MHz	

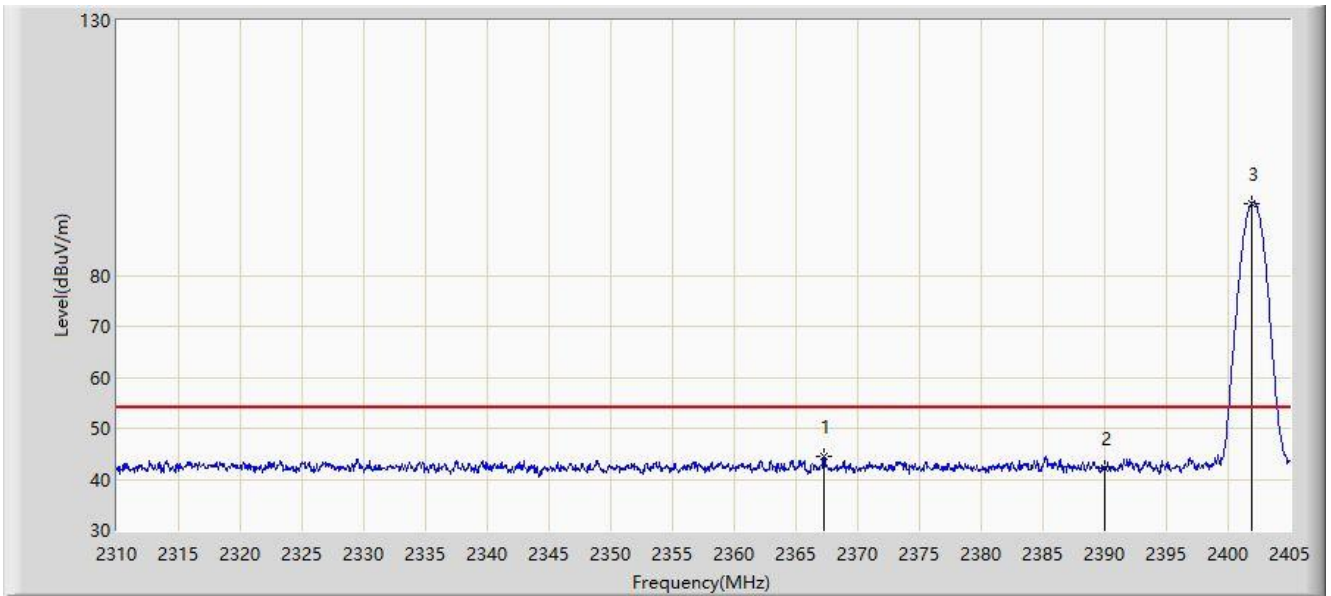

No	Flag	Mark	Frequency (MHz)	Measure Level (dBuV/m)	Reading Level (dBuV)	Margin (dB)	Limit (dBuV/m)	Factor (dB)	Type
1			2367.238	44.469	11.965	-9.531	54.000	32.504	AV
2			2390.000	42.251	9.847	-11.749	54.000	32.404	AV
3		*	2401.913	94.165	61.799	N/A	N/A	32.366	AV

Note: Measure Level (dB μ V/m) = Reading Level (dB μ V) + Factor (dB)

Factor (dB) = Cable Loss (dB) + Antenna Factor (dB/m)

Site: SIP-AC2	Time: 2021/06/20 - 14:37
Limit: FCC_Part15.209 RE(3m)	Engineer: Stephen Dong
Probe: SIP-AC2_BBHA9120D_1-18GHz	Polarity: Vertical
EUT: True Wireless Earphone	Power: Powered by Battery
Note: Transmit by BLE 1Mbps at Channel 2402MHz	

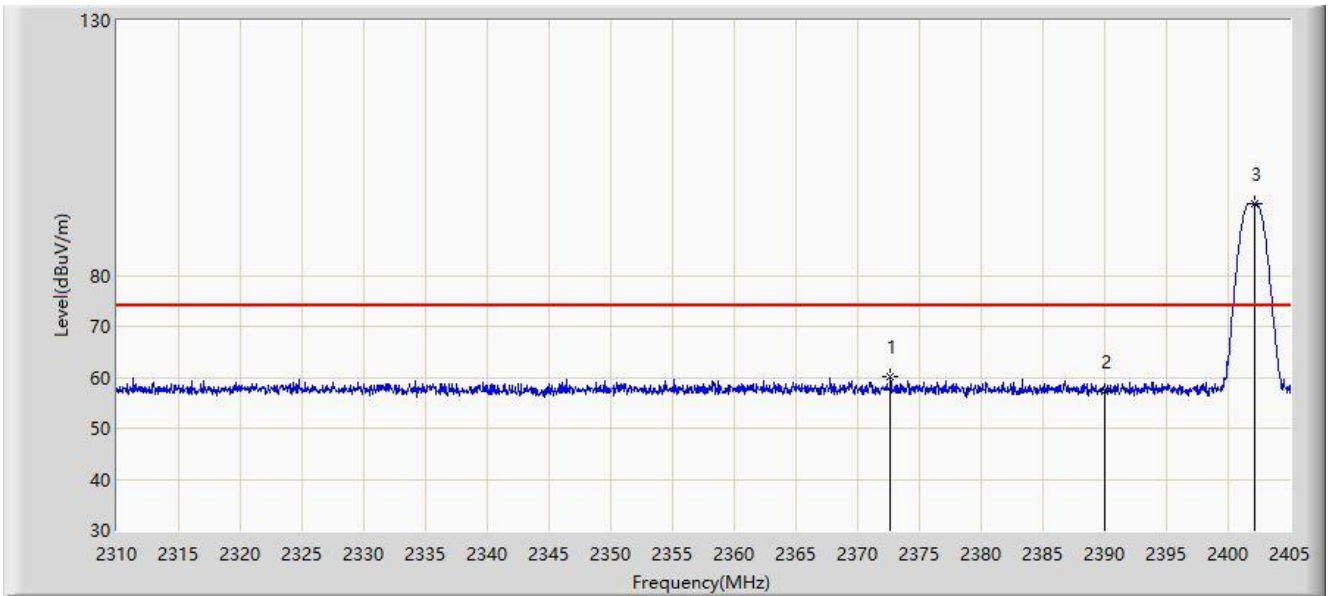

No	Flag	Mark	Frequency (MHz)	Measure Level (dBuV/m)	Reading Level (dBuV)	Margin (dB)	Limit (dBuV/m)	Factor (dB)	Type
1			2372.653	60.262	27.766	-13.738	74.000	32.497	PK
2			2390.000	57.276	24.872	-16.724	74.000	32.404	PK
3		*	2402.150	94.036	61.670	N/A	N/A	32.365	PK

Note: Measure Level (dB μ V/m) = Reading Level (dB μ V) + Factor (dB)

Factor (dB) = Cable Loss (dB) + Antenna Factor (dB/m)

Site: SIP-AC2	Time: 2021/06/20 - 14:41
Limit: FCC_Part15.209 RE(3m)	Engineer: Stephen Dong
Probe: SIP-AC2_BBHA9120D_1-18GHz	Polarity: Vertical
EUT: True Wireless Earphone	Power: Powered by Battery
Note: Transmit by BLE 1Mbps at Channel 2402MHz	

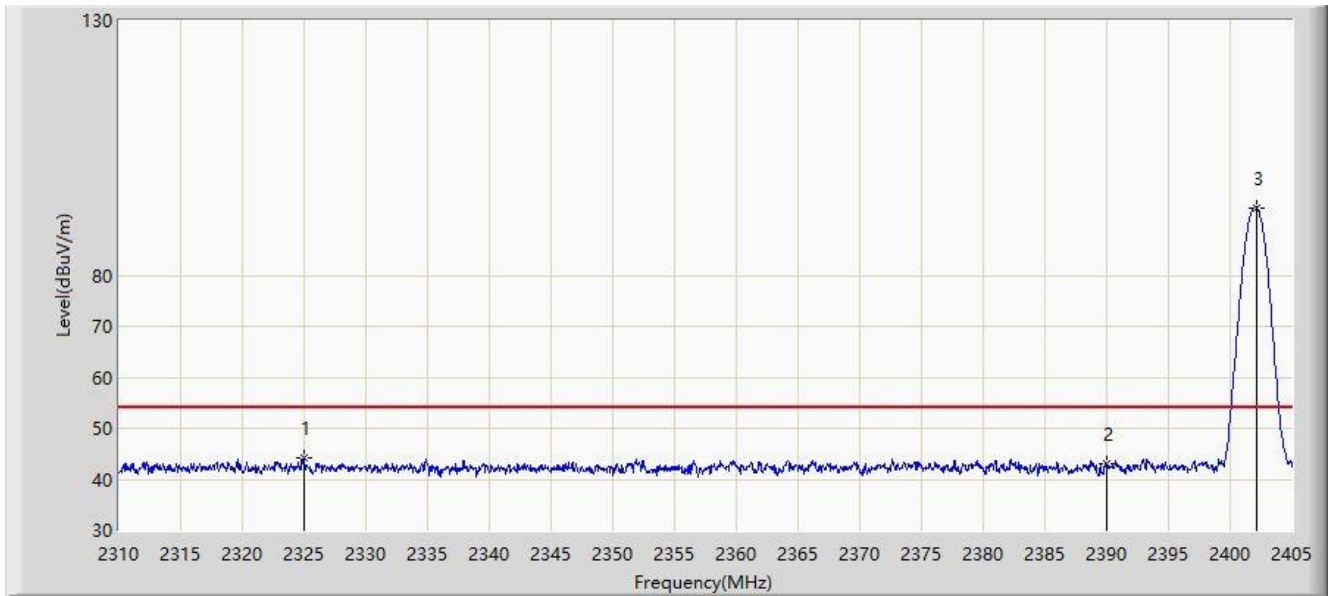

No	Flag	Mark	Frequency (MHz)	Measure Level (dBuV/m)	Reading Level (dBuV)	Margin (dB)	Limit (dBuV/m)	Factor (dB)	Type
1			2325.010	44.186	11.499	-9.814	54.000	32.687	AV
2			2390.000	42.966	10.562	-11.034	54.000	32.404	AV
3		*	2402.150	93.269	60.903	N/A	N/A	32.365	AV

Note: Measure Level (dB μ V/m) = Reading Level (dB μ V) + Factor (dB)

Factor (dB) = Cable Loss (dB) + Antenna Factor (dB/m)

Site: SIP-AC2	Time: 2021/06/20 - 14:41
Limit: FCC_Part15.209 RE(3m)	Engineer: Stephen Dong
Probe: SIP-AC2_BBHA9120D_1-18GHz	Polarity: Horizontal
EUT: True Wireless Earphone	Power: Powered by Battery
Note: Transmit by BLE 1Mbps at Channel 2480MHz	

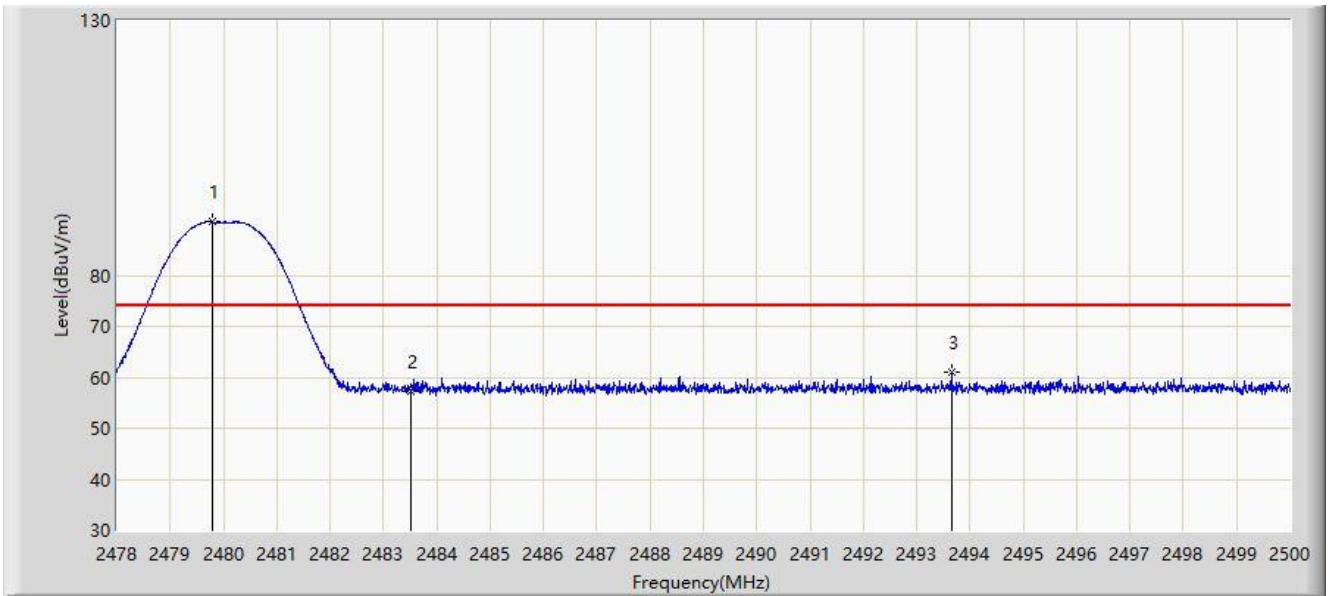

No	Flag	Mark	Frequency (MHz)	Measure Level (dBuV/m)	Reading Level (dBuV)	Margin (dB)	Limit (dBuV/m)	Factor (dB)	Type
1		*	2479.804	90.474	58.289	N/A	N/A	32.185	PK
2			2483.500	57.219	25.024	-16.781	74.000	32.195	PK
3			2493.653	60.922	28.699	-13.078	74.000	32.222	PK

Note: Measure Level (dB μ V/m) = Reading Level (dB μ V) + Factor (dB)

Factor (dB) = Cable Loss (dB) + Antenna Factor (dB/m)

Site: SIP-AC2	Time: 2021/06/20 - 14:45
Limit: FCC_Part15.209 RE(3m)	Engineer: Stephen Dong
Probe: SIP-AC2_BBHA9120D_1-18GHz	Polarity: Horizontal
EUT: True Wireless Earphone	Power: Powered by Battery
Note: Transmit by BLE 1Mbps at Channel 2480MHz	



No	Flag	Mark	Frequency (MHz)	Measure Level (dBuV/m)	Reading Level (dBuV)	Margin (dB)	Limit (dBuV/m)	Factor (dB)	Type
1		*	2480.002	89.625	57.439	N/A	N/A	32.186	AV
2			2483.500	43.116	10.921	-10.884	54.000	32.195	AV
3			2492.322	44.536	12.317	-9.464	54.000	32.219	AV

Note: Measure Level (dB μ V/m) = Reading Level (dB μ V) + Factor (dB)

Factor (dB) = Cable Loss (dB) + Antenna Factor (dB/m)

Site: SIP-AC2	Time: 2021/06/20 - 14:46
Limit: FCC_Part15.209 RE(3m)	Engineer: Stephen Dong
Probe: SIP-AC2_BBHA9120D_1-18GHz	Polarity: Vertical
EUT: True Wireless Earphone	Power: Powered by Battery
Note: Transmit by BLE 1Mbps at Channel 2480MHz	

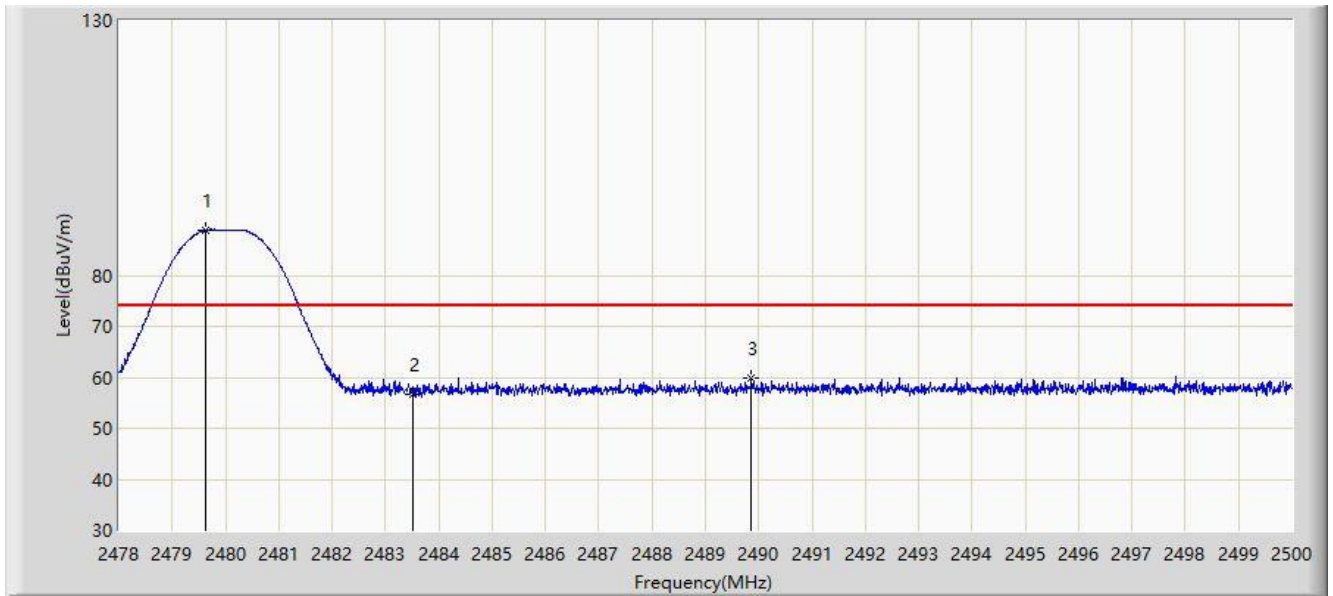

No	Flag	Mark	Frequency (MHz)	Measure Level (dBuV/m)	Reading Level (dBuV)	Margin (dB)	Limit (dBuV/m)	Factor (dB)	Type
1		*	2479.617	88.867	56.682	N/A	N/A	32.184	PK
2			2483.500	56.786	24.591	-17.214	74.000	32.195	PK
3			2489.858	59.885	27.673	-14.115	74.000	32.213	PK

Note: Measure Level (dB μ V/m) = Reading Level (dB μ V) + Factor (dB)

Factor (dB) = Cable Loss (dB) + Antenna Factor (dB/m)

Site: SIP-AC2	Time: 2021/06/20 - 14:49
Limit: FCC_Part15.209 RE(3m)	Engineer: Stephen Dong
Probe: SIP-AC2_BBHA9120D_1-18GHz	Polarity: Vertical
EUT: True Wireless Earphone	Power: Powered by Battery
Note: Transmit by BLE 1Mbps at Channel 2480MHz	

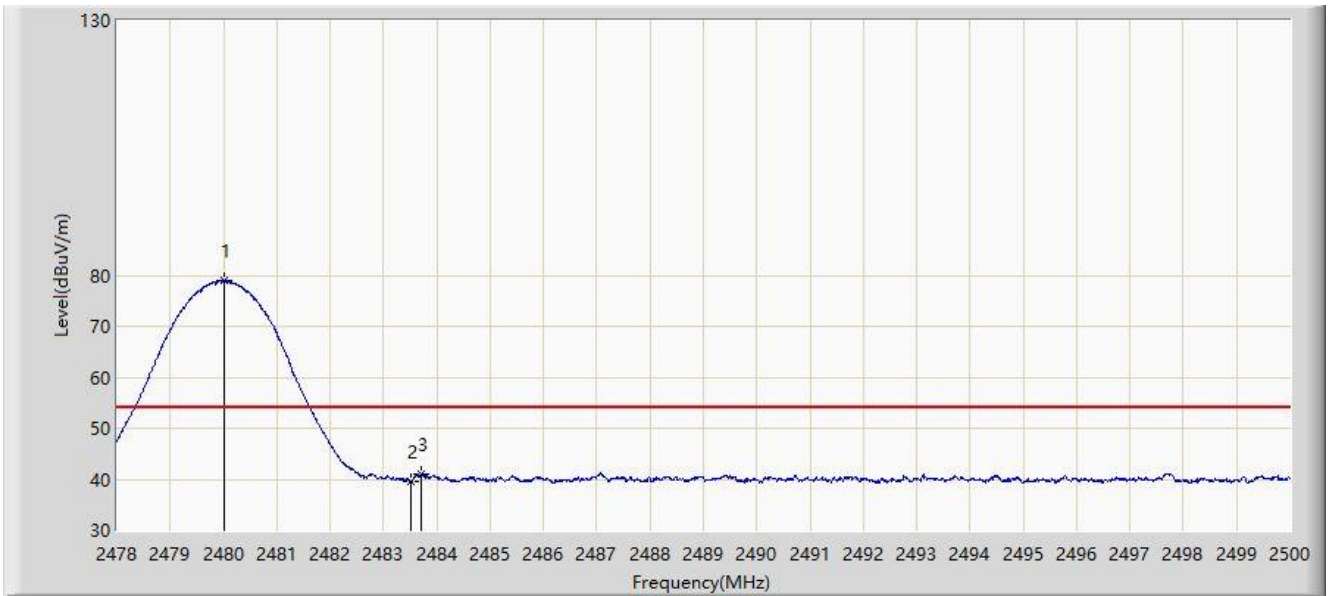

No	Flag	Mark	Frequency (MHz)	Measure Level (dBuV/m)	Reading Level (dBuV)	Margin (dB)	Limit (dBuV/m)	Factor (dB)	Type
1		*	2480.013	78.921	46.735	N/A	N/A	32.186	AV
2			2483.500	39.596	7.401	-14.404	54.000	32.195	AV
3			2483.720	41.089	8.893	-12.911	54.000	32.196	AV

Note: Measure Level (dB μ V/m) = Reading Level (dB μ V) + Factor (dB)

Factor (dB) = Cable Loss (dB) + Antenna Factor (dB/m)

Site: SIP-AC2	Time: 2021/06/20 - 14:50
Limit: FCC_Part15.209 RE(3m)	Engineer: Stephen Dong
Probe: SIP-AC2_BBHA9120D_1-18GHz	Polarity: Horizontal
EUT: True Wireless Earphone	Power: Powered by Battery
Note: Transmit by BLE 2Mbps at Channel 2402MHz	

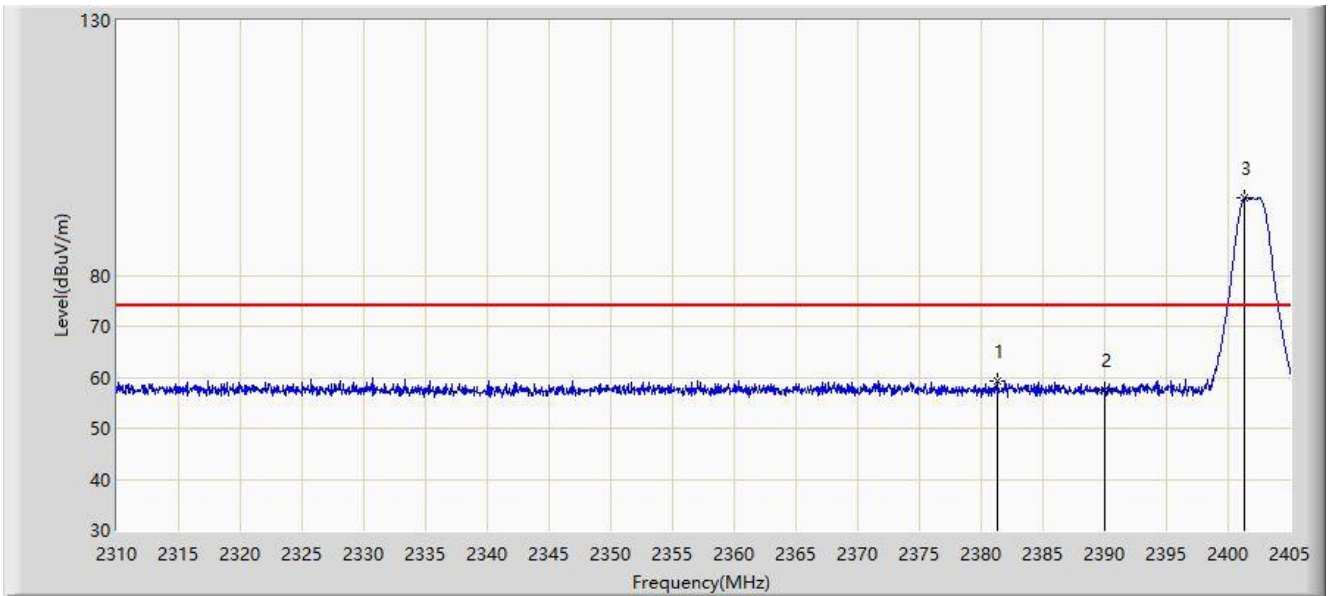

No	Flag	Mark	Frequency (MHz)	Measure Level (dBuV/m)	Reading Level (dBuV)	Margin (dB)	Limit (dBuV/m)	Factor (dB)	Type
1			2381.298	59.391	26.929	-14.609	74.000	32.462	PK
2			2390.000	57.504	25.100	-16.496	74.000	32.404	PK
3		*	2401.343	95.132	62.765	N/A	N/A	32.367	PK

Note: Measure Level (dB μ V/m) = Reading Level (dB μ V) + Factor (dB)

Factor (dB) = Cable Loss (dB) + Antenna Factor (dB/m)

Site: SIP-AC2	Time: 2021/06/20 - 14:53
Limit: FCC_Part15.209 RE(3m)	Engineer: Stephen Dong
Probe: SIP-AC2_BBHA9120D_1-18GHz	Polarity: Horizontal
EUT: True Wireless Earphone	Power: Powered by Battery
Note: Transmit by BLE 2Mbps at Channel 2402MHz	

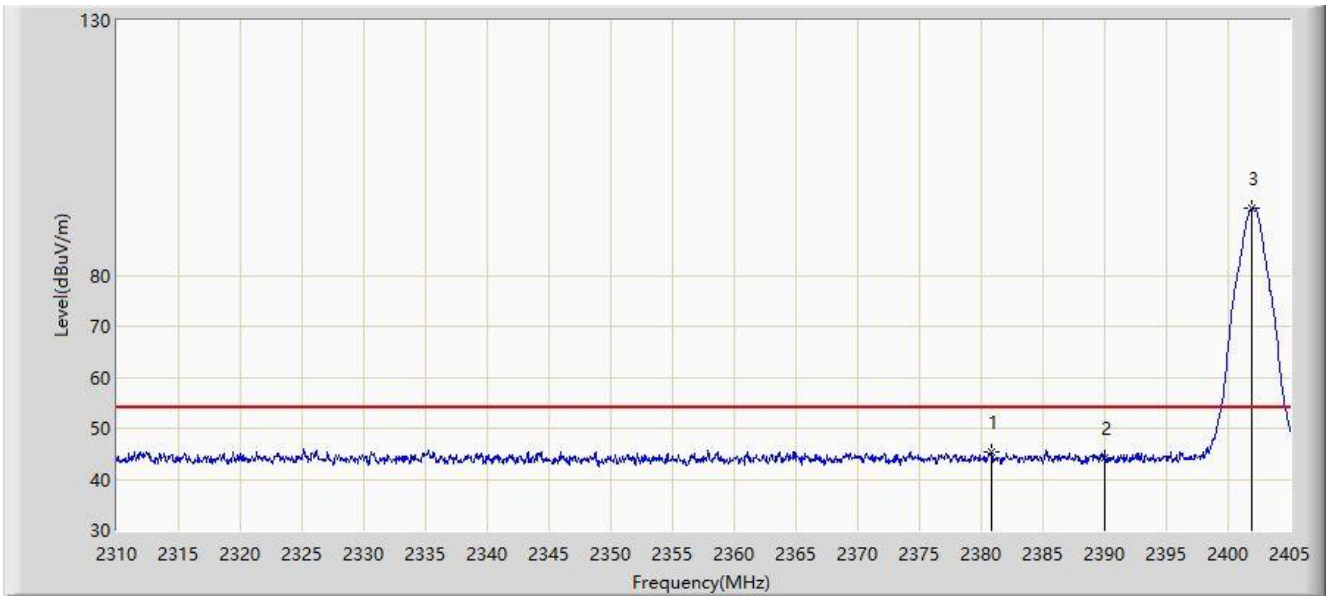

No	Flag	Mark	Frequency (MHz)	Measure Level (dBuV/m)	Reading Level (dBuV)	Margin (dB)	Limit (dBuV/m)	Factor (dB)	Type
1			2380.870	45.451	12.986	-8.549	54.000	32.464	AV
2			2390.000	44.315	11.911	-9.685	54.000	32.404	AV
3		*	2401.960	93.243	60.877	N/A	N/A	32.366	AV

Note: Measure Level (dB μ V/m) = Reading Level (dB μ V) + Factor (dB)

Factor (dB) = Cable Loss (dB) + Antenna Factor (dB/m)

Site: SIP-AC2	Time: 2021/06/20 - 14:54
Limit: FCC_Part15.209 RE(3m)	Engineer: Stephen Dong
Probe: SIP-AC2_BBHA9120D_1-18GHz	Polarity: Vertical
EUT: True Wireless Earphone	Power: Powered by Battery
Note: Transmit by BLE 2Mbps at Channel 2402MHz	

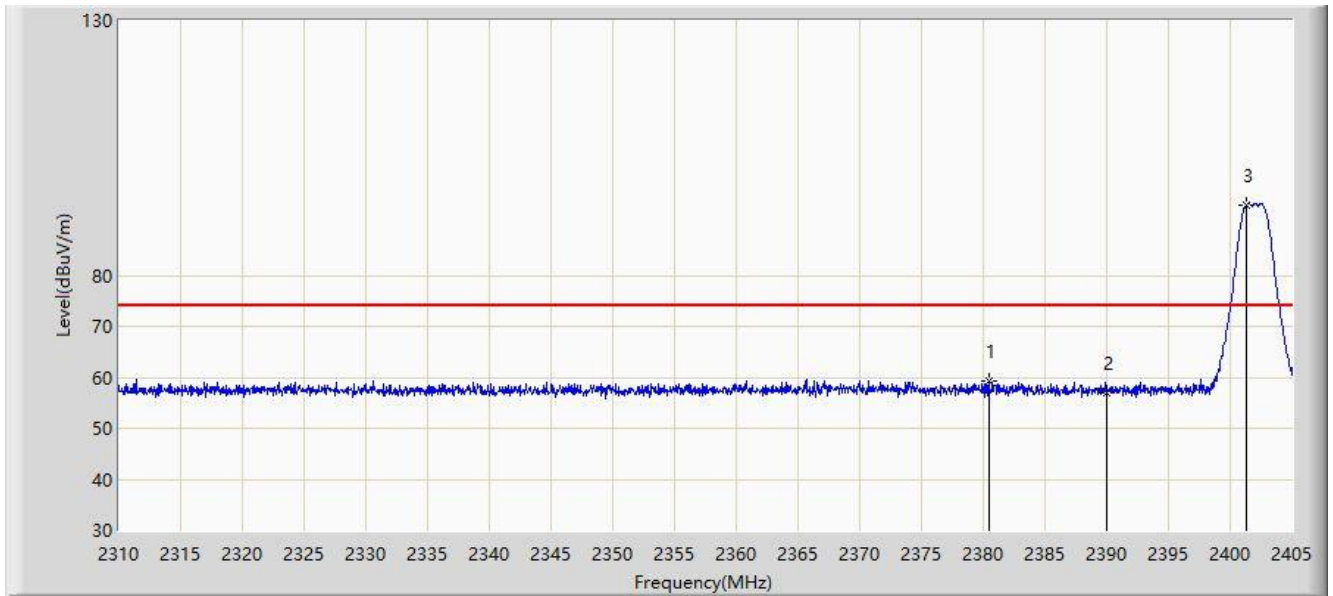

No	Flag	Mark	Frequency (MHz)	Measure Level (dBuV/m)	Reading Level (dBuV)	Margin (dB)	Limit (dBuV/m)	Factor (dB)	Type
1			2380.442	59.145	26.678	-14.855	74.000	32.467	PK
2			2390.000	57.095	24.691	-16.905	74.000	32.404	PK
3		*	2401.343	93.911	61.544	N/A	N/A	32.367	PK

Note: Measure Level (dB μ V/m) = Reading Level (dB μ V) + Factor (dB)

Factor (dB) = Cable Loss (dB) + Antenna Factor (dB/m)

Site: SIP-AC2	Time: 2021/06/20 - 14:58
Limit: FCC_Part15.209 RE(3m)	Engineer: Stephen Dong
Probe: SIP-AC2_BBHA9120D_1-18GHz	Polarity: Vertical
EUT: True Wireless Earphone	Power: Powered by Battery
Note: Transmit by BLE 2Mbps at Channel 2402MHz	

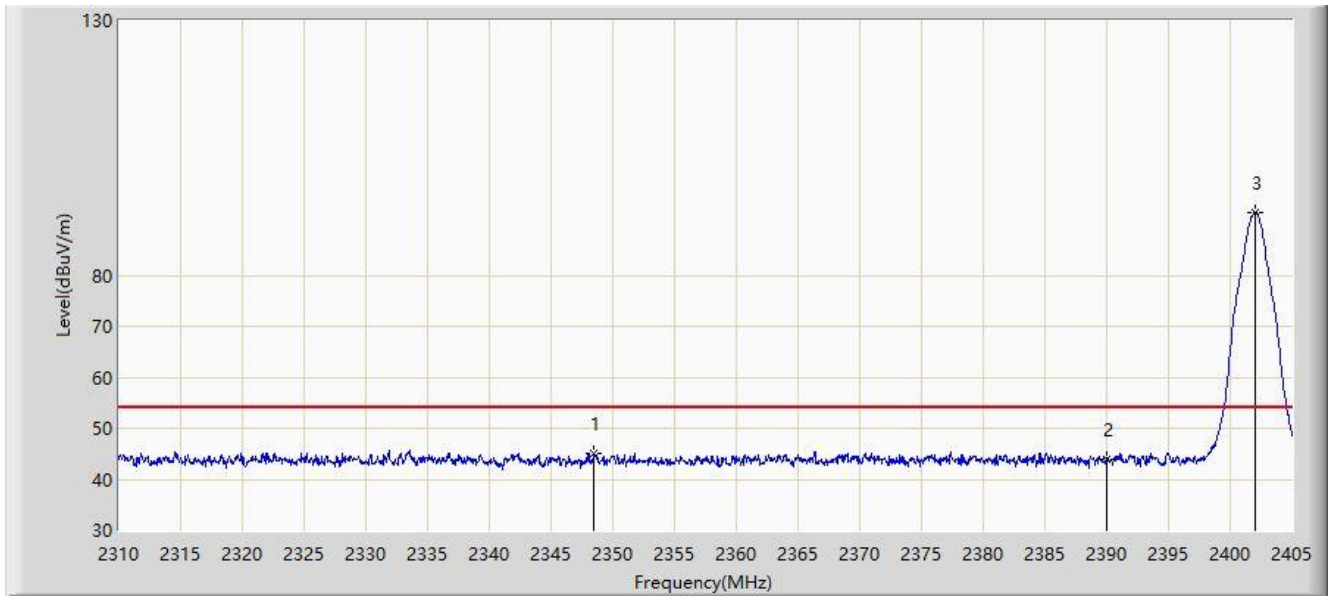

No	Flag	Mark	Frequency (MHz)	Measure Level (dBuV/m)	Reading Level (dBuV)	Margin (dB)	Limit (dBuV/m)	Factor (dB)	Type
1			2348.475	45.070	12.653	-8.930	54.000	32.417	AV
2			2390.000	43.871	11.467	-10.129	54.000	32.404	AV
3		*	2402.008	92.290	59.924	N/A	N/A	32.366	AV

Note: Measure Level (dB μ V/m) = Reading Level (dB μ V) + Factor (dB)

Factor (dB) = Cable Loss (dB) + Antenna Factor (dB/m)

Site: SIP-AC2	Time: 2021/06/20 - 14:58
Limit: FCC_Part15.209 RE(3m)	Engineer: Stephen Dong
Probe: SIP-AC2_BBHA9120D_1-18GHz	Polarity: Horizontal
EUT: True Wireless Earphone	Power: Powered by Battery
Note: Transmit by BLE 2Mbps at Channel 2480MHz	

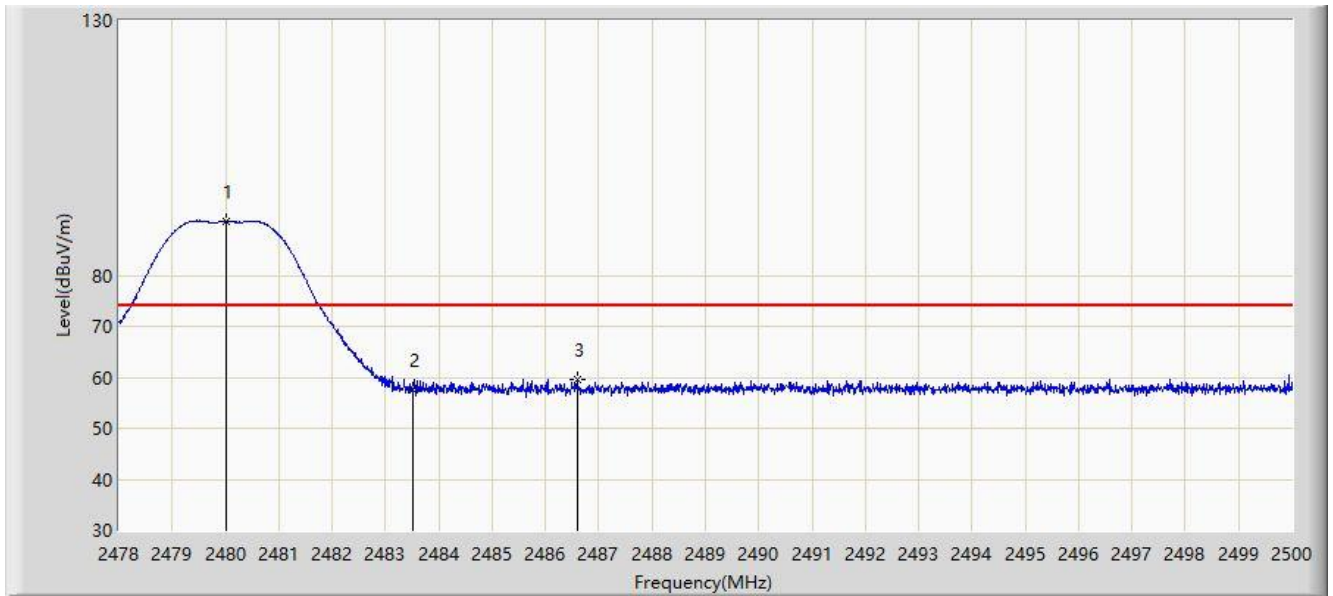

No	Flag	Mark	Frequency (MHz)	Measure Level (dBuV/m)	Reading Level (dBuV)	Margin (dB)	Limit (dBuV/m)	Factor (dB)	Type
1		*	2480.002	90.715	58.529	N/A	N/A	32.186	PK
2			2483.500	57.392	25.197	-16.608	74.000	32.195	PK
3			2486.602	59.459	27.255	-14.541	74.000	32.204	PK

Note: Measure Level (dB μ V/m) = Reading Level (dB μ V) + Factor (dB)

Factor (dB) = Cable Loss (dB) + Antenna Factor (dB/m)

Site: SIP-AC2	Time: 2021/06/20 - 15:02
Limit: FCC_Part15.209 RE(3m)	Engineer: Stephen Dong
Probe: SIP-AC2_BBHA9120D_1-18GHz	Polarity: Horizontal
EUT: True Wireless Earphone	Power: Powered by Battery
Note: Transmit by BLE 2Mbps at Channel 2480MHz	

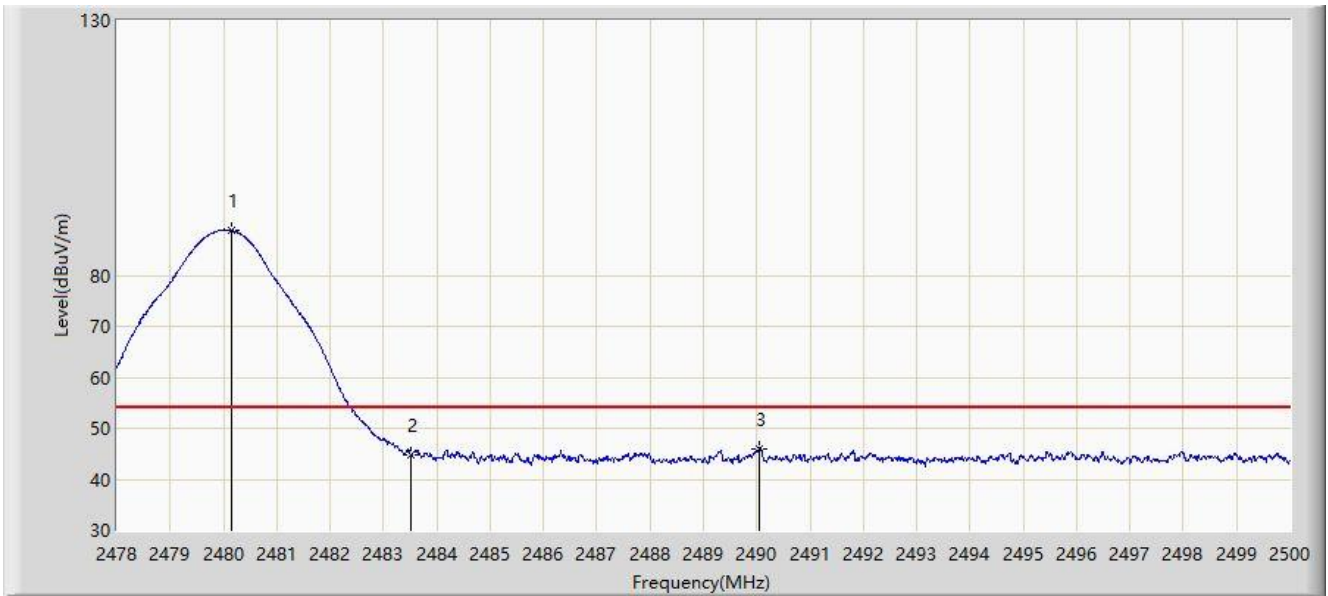

No	Flag	Mark	Frequency (MHz)	Measure Level (dBuV/m)	Reading Level (dBuV)	Margin (dB)	Limit (dBuV/m)	Factor (dB)	Type
1		*	2480.145	88.869	56.683	N/A	N/A	32.186	AV
2			2483.500	44.916	12.721	-9.084	54.000	32.195	AV
3			2490.034	46.050	13.837	-7.950	54.000	32.213	AV

Note: Measure Level (dB μ V/m) = Reading Level (dB μ V) + Factor (dB)

Factor (dB) = Cable Loss (dB) + Antenna Factor (dB/m)

Site: SIP-AC2	Time: 2021/06/20 - 15:02
Limit: FCC_Part15.209 RE(3m)	Engineer: Stephen Dong
Probe: SIP-AC2_BBHA9120D_1-18GHz	Polarity: Vertical
EUT: True Wireless Earphone	Power: Powered by Battery
Note: Transmit by BLE 2Mbps at Channel 2480MHz	

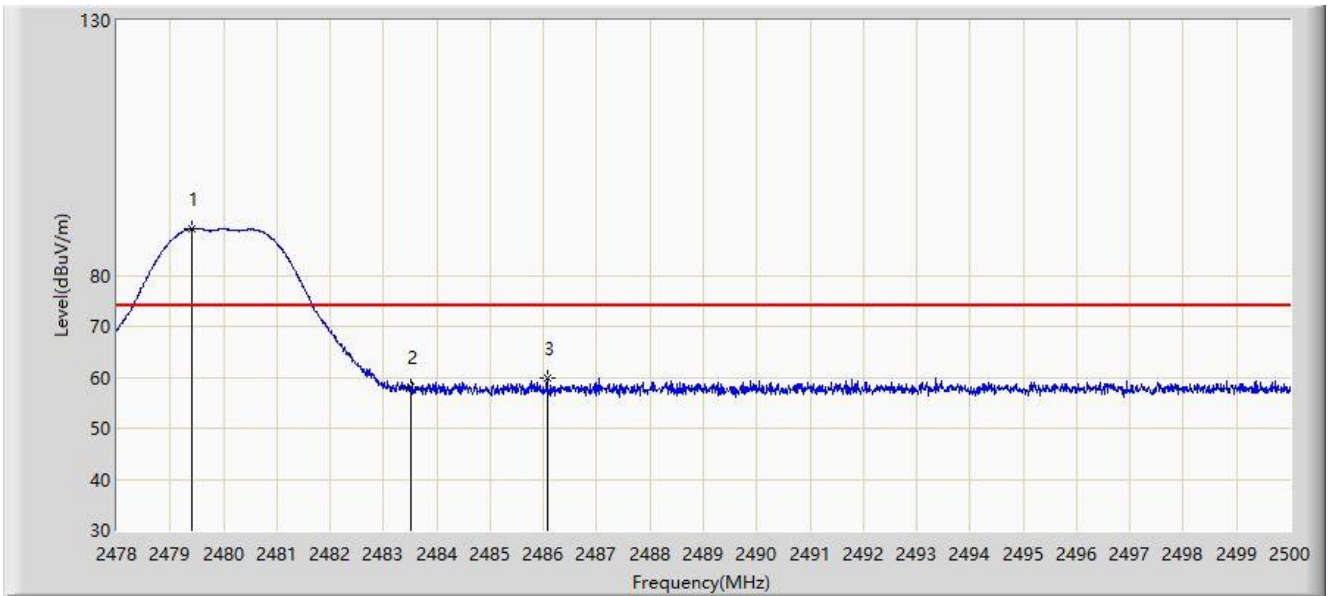

No	Flag	Mark	Frequency (MHz)	Measure Level (dBuV/m)	Reading Level (dBuV)	Margin (dB)	Limit (dBuV/m)	Factor (dB)	Type
1		*	2479.408	89.199	57.015	N/A	N/A	32.184	PK
2			2483.500	58.212	26.017	-15.788	74.000	32.195	PK
3			2486.074	59.754	27.552	-14.246	74.000	32.202	PK

Note: Measure Level (dB μ V/m) = Reading Level (dB μ V) + Factor (dB)

Factor (dB) = Cable Loss (dB) + Antenna Factor (dB/m)

Site: SIP-AC2	Time: 2021/06/20 - 15:06
Limit: FCC_Part15.209 RE(3m)	Engineer: Stephen Dong
Probe: SIP-AC2_BBHA9120D_1-18GHz	Polarity: Vertical
EUT: True Wireless Earphone	Power: Powered by Battery
Note: Transmit by BLE 2Mbps at Channel 2480MHz	

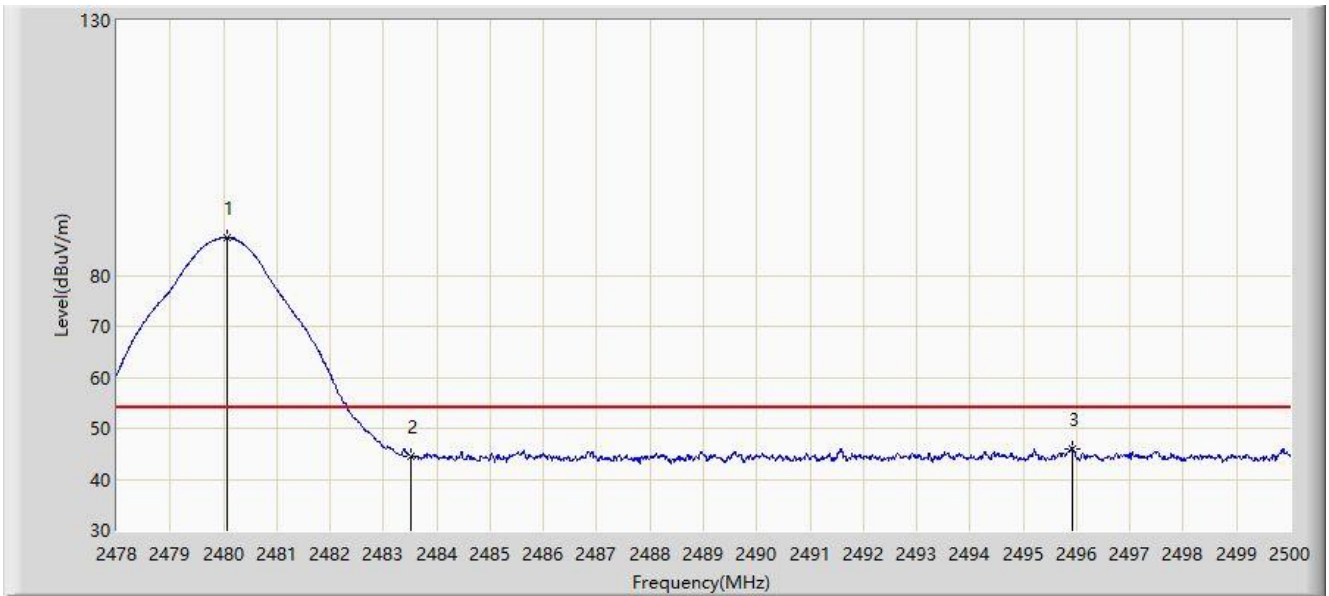

No	Flag	Mark	Frequency (MHz)	Measure Level (dBuV/m)	Reading Level (dBuV)	Margin (dB)	Limit (dBuV/m)	Factor (dB)	Type
1		*	2480.079	87.393	55.207	N/A	N/A	32.186	AV
2			2483.500	44.550	12.355	-9.450	54.000	32.195	AV
3			2495.919	46.073	13.844	-7.927	54.000	32.229	AV

Note: Measure Level (dB μ V/m) = Reading Level (dB μ V) + Factor (dB)

Factor (dB) = Cable Loss (dB) + Antenna Factor (dB/m)

5.8. AC Conducted Emissions Measurement

5.8.1. Test Limit

FCC Part 15 Subpart C Paragraph 15.207 Limits		
Frequency (MHz)	QP (dB μ V)	Average (dB μ V)
0.15 - 0.50	66 - 56	56 - 46
0.50 - 5.0	56	46
5.0 - 30	60	50

Note 1: The lower limit shall apply at the transition frequencies.

Note 2: The limit decreases linearly with the logarithm of the frequency in the range 0.15MHz to 0.5MHz.

5.8.2. Test Setup

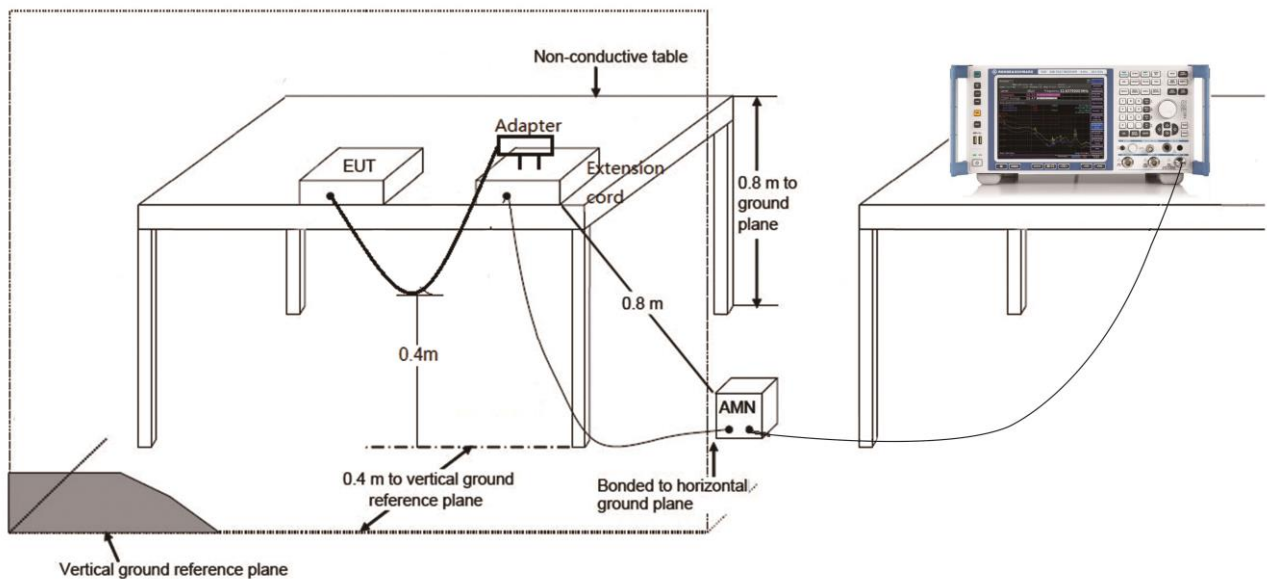

5.8.3. Test Result

Site: SIP-SR2	Time: 2021/06/25
Limit: FCC_Part15.207_CE_AC Power	Engineer: Wayen Wang
Probe: SIP-SR2-ENV216_101684_With Connector	Polarity: Line
EUT: True Wireless Earphone	Power: AC 120V/60Hz
Note: Test Mode 1	

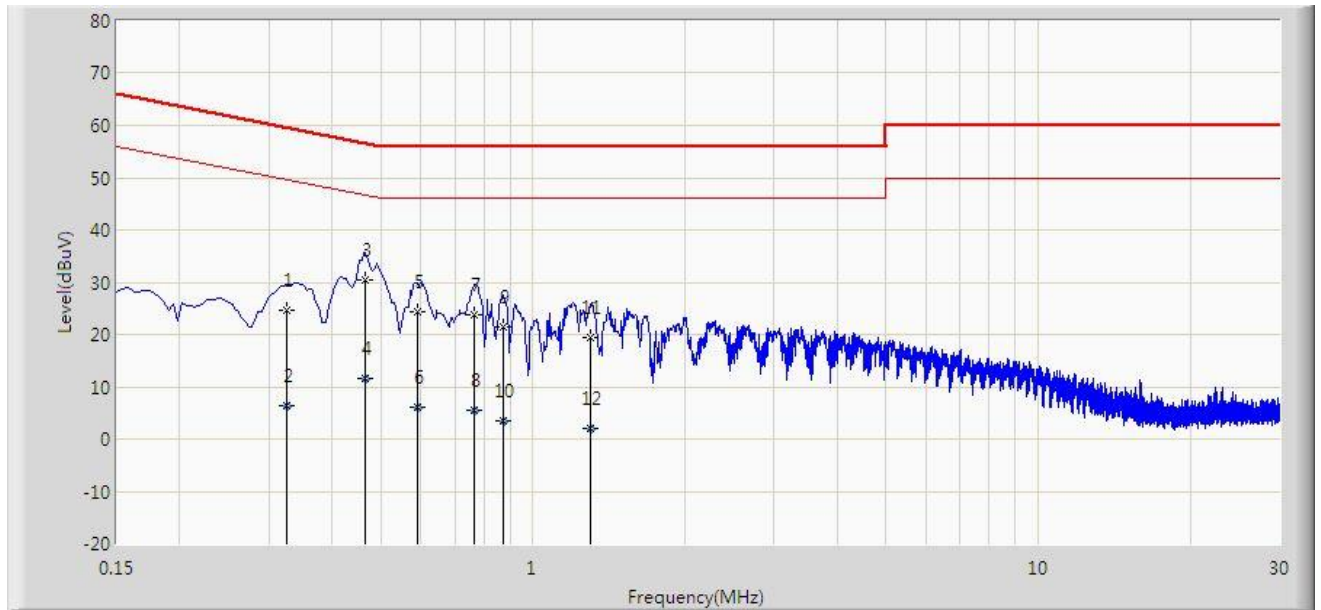

No	Flag	Mark	Frequency (MHz)	Measure Level (dBuV)	Reading Level (dBuV)	Margin (dB)	Limit (dBuV)	Factor (dB)	Type
1			0.326	24.530	14.983	-35.022	59.552	9.547	QP
2			0.326	6.381	-3.166	-43.172	49.552	9.547	AV
3		*	0.466	30.504	20.946	-26.081	56.585	9.557	QP
4			0.466	11.532	1.975	-35.052	46.585	9.557	AV
5			0.590	24.486	14.926	-31.514	56.000	9.560	QP
6			0.590	6.216	-3.344	-39.784	46.000	9.560	AV
7			0.766	23.662	14.102	-32.338	56.000	9.560	QP
8			0.766	5.512	-4.048	-40.488	46.000	9.560	AV
9			0.874	21.462	11.905	-34.538	56.000	9.557	QP
10			0.874	3.539	-6.018	-42.461	46.000	9.557	AV
11			1.298	19.278	9.718	-36.722	56.000	9.560	QP
12			1.298	1.984	-7.576	-44.016	46.000	9.560	AV

Note: Measure Level (dBμV) = Reading Level (dBμV) + Factor (dB)

Factor (dB) = Cable Loss (dB) + LISN Factor (dB).

Site: SIP-SR2	Time: 2021/06/25
Limit: FCC_Part15.207_CE_AC Power	Engineer: Wayen Wang
Probe: SIP-SR2-ENV216_101684_With Connector	Polarity: Neutral
EUT: True Wireless Earphone	Power: AC 120V/60Hz
Note: Test Mode 1	

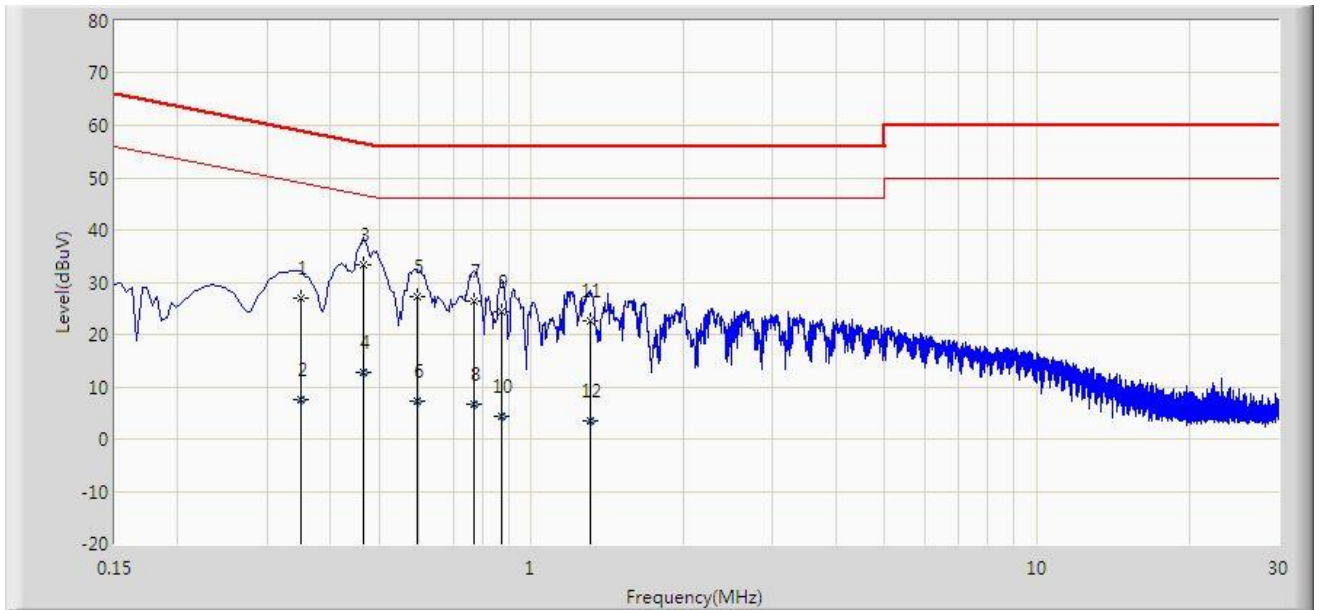

No	Flag	Mark	Frequency (MHz)	Measure Level (dBuV)	Reading Level (dBuV)	Margin (dB)	Limit (dBuV)	Factor (dB)	Type
1			0.350	27.083	17.561	-31.879	58.962	9.523	QP
2			0.350	7.462	-2.061	-41.501	48.962	9.523	AV
3		*	0.466	33.199	23.662	-23.385	56.585	9.537	QP
4			0.466	12.777	3.239	-33.808	46.585	9.537	AV
5			0.594	27.163	17.623	-28.837	56.000	9.540	QP
6			0.594	7.310	-2.230	-38.690	46.000	9.540	AV
7			0.770	26.375	16.835	-29.625	56.000	9.540	QP
8			0.770	6.557	-2.983	-39.443	46.000	9.540	AV
9			0.874	24.237	14.700	-31.763	56.000	9.537	QP
10			0.874	4.447	-5.090	-41.553	46.000	9.537	AV
11			1.306	22.551	13.008	-33.449	56.000	9.543	QP
12			1.306	3.412	-6.131	-42.588	46.000	9.543	AV

Note: Measure Level (dBμV) = Reading Level (dBμV) + Factor (dB)

Factor (dB) = Cable Loss (dB) + LISN Factor (dB).

6. CONCLUSION

The data collected relate only the item(s) tested and show that the device is compliance with Part 15C of the FCC rules.

————— The End —————

Appendix A - Test Setup Photograph

Refer to "2106RSU032-UT" file.

Appendix B - EUT Photograph

Refer to "2106RSU032-UE" file.