

Exhibit C

Measurement Rerort

OPTEx CO., LTD.

FCC ID.:DC9TS-10U

Hand-Held Transmitter

FCC Part 15 Subpart C
EMI TEST REPORT

of

E.U.T. : HAND HELD TRANSMITTER

FCC ID. : DC9TS-10U

MODEL : TS-10U

Working Frequency : 418 MHz

for

APPLICANT : OPTEX CO., LTD.

ADDRESS : 3-4-46 Nionohama Otsu 520 Japan

Test Performed by

ELECTRONICS TESTING CENTER, TAIWAN
NO. 8 LANE 29, WENMIMG ROAD,
LOSHAN TSUN, KWEISHAN HSIANG,
TAOYUAN, TAIWAN, R.O.C.

Tel:(03)3280026-32

Fax:(03)3280034

Report Number : ET87R-07-046-04

TEST REPORT CERTIFICATION

Applicant : OPTEX CO., LTD.
3-4-46 Nionohama Otsu 520 Japan

Manufacturer : Interquartz (M) Berhad. Ltd.
Plot 149, Bayan Lepas, Free Trade Zone, Phase 1, 11900 Penang,
Malaysia

Description of EUT :

a) Type of EUT : HAND HELD TRANSMITTER
b) Trade Name : OPTEX
c) Model No. : TS-10U
d) FCC ID : DC9TS-10U
e) Working Frequency : 418 MHz
f) Power Supply : DC 3V (1.5V × 2 Batteries)

Regulation Applied : FCC Rules and Regulations Part 15 Subpart C (1996)

I HEREBY CERTIFY THAT; The data shown in this report were made in accordance with the procedures given in ANSI C63.4 and the energy emitted by the device was founded to be within the limits applicable. I assume full responsibility for accuracy and completeness of these data.

Issued Date : JUL. 29, 1998

Test Engineer : Tien Lu Liao
(Tien Lu Liao)

Approve & Authorized Signer : Will Yauo
Will Yauo, Supervisor
EMI Test Site of ELECTRONICS
TESTING CENTER, TAIWAN

Table of Contents

Page

| | |
|--|-----------|
| 1. GENERAL INFORMATION | 1 |
| 1.1 PRODUCT DESCRIPTION | 1 |
| 1.2 CHARACTERISTICS OF DEVICE: | 1 |
| 1.3 TEST METHODOLOGY | 1 |
| 1.4 TEST FACILITY..... | 2 |
| 2. DEFINITION AND LIMITS | 2 |
| 2.1 DEFINITION | 2 |
| 2.2 RESTRICTED BANDS OF OPERATION | 2 |
| 2.3 LIMITATION | 3 |
| 2.4 LABELING REQUIREMENT | 4 |
| 2.5 USER INFORMATION | 4 |
| 3. RADIATED EMISSION MEASUREMENT..... | 5 |
| 3.1 APPLICABLE STANDARD | 5 |
| 3.2 MEASUREMENT PROCEDURE | 5 |
| 3.3 TEST DATA | 7 |
| 3.4 FIELD STRENGTH CALCULATION..... | 8 |
| 3.5 ACTIVATE TIME..... | 8 |
| 3.6 CALCULATION OF DUTY FACTOR..... | 8 |
| <i>a. Full Cycle of The Pulse Train</i> | 9 |
| <i>b. Detail of The Pulse Train</i> | 10 |
| 3.7 RADIATED TEST EQUIPMENT | 12 |
| 3.8 MEASURING INSTRUMENT SETUP | 12 |
| 3.9 RADIATED MEASUREMENT PHOTOS | 13 |
| 4. BANDWIDTH OF EMISSION..... | 14 |
| 4.1 APPLICABLE STANDARD PLOT GRAPHIC OF BANDWIDTH..... | 14 |
| 4.2 BANDWIDTH TEST EQUIPMENT | 14 |
| 4.3 PLOT GRAPHIC OF BANDWIDTH | 14 |
| 5. CONDUCTED EMISSION MEASUREMENT | 16 |
| 5.1 STANDARD APPLICABLE | 16 |

1. GENERAL INFORMATION

1.1 Product Description

| | |
|----------------------|------------------------------|
| a) Type of EUT | : HAND HELD TRANSMITTER |
| b) Trade Name | : OPTEX |
| c) Model No. | : TS-10U |
| d) FCC ID | : DC9TS-10U |
| e) Working Frequency | : 418MHz |
| f) Power Supply | : DC 3V (1.5V × 2 Batteries) |

1.2 Characteristics of Device:

1.3 Test Methodology

Both conducted and radiated testing were performed according to the procedures in chapter 13 of ANSI C63.4.

The HAND HELD TRANSMITTER under test was operated continuously in its normal operating mode for the purpose of the measurements. In order to secure the continuous operation of the device under test, rewiring in the circuit was done by the manufacturer so as to affect its intended operation.

The receiving antenna polarized horizontally was varied from 1 to 4 meters and the wooden turntable was rotated through 360 degrees to obtain the highest reading on the field strength meter or on the display of the spectrum analyzer. And also, each emission was to be maximized by changing the orientation of the HAND HELD TRANSMITTER under test. In order to determining the average value during one pulse train of the radiated power generated from the HAND HELD TRANSMITTER under test, the encoded wave form in the time domain was used.

1.4 Test Facility

The open area test site and conducted measurement facility used to collect the radiated data is located on the roof top of Building at No.34, 5 Lin, Din Fu Tsun, Lin Kou, Taipei, Taiwan, R.O.C.

This site has been fully described in a report submitted to your office, and accepted in a letter dated Feb. 10, 1997.

2. DEFINITION AND LIMITS

2.1 Definition

Intentional radiator:

A device that intentionally generates and emits radio frequency energy by radiation or induction.

2.2 Restricted Bands of Operation

Only spurious emissions are permitted in any of the frequency bands listed below:

| MHz | MHz | MHz | GHz |
|-------------------|-----------------------|---------------|-------------|
| 0.090 - 0.110 | 16.42-16.423 | 399.9-410 | 4.5-5.25 |
| 0.495 - 0.505 ** | 16.69475 - 16.69525 | 608-614 | 5.35-5.46 |
| 2.1735 - 2.1905 | 16.80425 - 16.80475 | 960-1240 | 7.25-7.75 |
| 4.125-4.128 | 25.5-25.67 | 1300-1427 | 8.025-8.5 |
| 4.17725-4.17775 | 37.5-38.25 | 1435-1626.5 | 9.0-9.2 |
| 4.20725-4.20775 | 73-74.6 | 1645.5-1646.5 | 9.3-9.5 |
| 6.215-6.218 | 74.8-75.2 | 1660-1710 | 10.6-12.7 |
| 6.26775-6.26825 | 108-121.94 | 1718.8-1722.2 | 13.25-13.4 |
| 6.31175-6.31225 | 123-138 | 2200-2300 | 14.47-14.5 |
| 8.291-8.294 | 149.9-150.05 | 2310-2390 | 15.35-16.2 |
| 8.362-8.366 | 156.52475 - 156.52525 | 2483.5-2500 | 17.7-21.4 |
| 8.37625-8.38675 | 156.7-156.9 | 2655-2900 | 22.01-23.12 |
| 8.41425-8.41475 | 162.0125-167.17 | 3260-3267 | 23.6-24.0 |
| 12.29-12.293 | 167.72-173.2 | 3332-3339 | 31.2-31.8 |
| 12.51975-12.52025 | 240-285 | 3345.8-3358 | 36.43-36.5 |
| 12.57675-12.57725 | 322-335.4 | 3360-4400 | Above 38.6 |
| 13.36-13.41 | | | |

Remark "***": Until February 1, 1999, this restricted band shall be 0.490-0.510 MHz

2.3 Limitation

(1) Conducted Emission Limits :

For an intentional radiator which is designed to be connected to the public utility (AC) power line, the conducted limit is the following:

| Frequency (MHz) | Emission (μ V) | Emission (dB μ V) |
|-------------------|----------------------|-------------------------|
| 0.45 - 30.0 | 250 | 48.0 |

(2) Radiated Emission Limits :

According to 15.231 ,Periodic operation in the band 40.66-40.70 MHz and above 70 MHz, the field strength of emissions from intentional radiators operated under this section shall not exceed the following:

| Frequency Band (MHz) | Field strength of Fundamental (uV/m) | Field strength of Spurious (uV/m) |
|----------------------|--------------------------------------|-----------------------------------|
| 40.66-40.70 | 2250 | 225 |
| 70-130 | 1250 | 125 |
| 130-174 | *1,250 to 3,750 | *125 to 375 |
| 174-260 | 3750 | 375 |
| 260-470 | *3,750 to 12,500 | *375 to 1250 |
| Above 470 | 12500 | 1250 |

* Linear interpolations.

According to 15.235, the field strength of emissions from intentional radiators operated under these frequency bands shall not exceed the following:

| Fundamental Frequency (MHz) | Field Strength of Fundamental | |
|-----------------------------|-------------------------------|------------------|
| | μ V/meter | dB μ V/meter |
| 49.82 - 49.90 | 10000 | 80 |

Field strength limits are at the distance of 3 meters, emissions radiated outside of the specified bands, shall be according to the general radiated limits in 15.209,as following table:

| Other Frequencies (MHz) | Field Strength of Fundamental | |
|-------------------------|-------------------------------|------------------|
| | μ V/meter | dB μ V/meter |
| 30 - 88 | 100 | 40.0 |
| 88 - 216 | 150 | 43.5 |
| 216 - 960 | 200 | 46.0 |
| Above 960 | 500 | 54.0 |

As shown in 15.35(b), for frequencies above 1000MHz, the field strength limits are based on average detector, however, the peak field strength of any emission shall not exceed the maximum permitted average limits, specified above by more than 20 dB under any condition of modulation.

(3) Limit of transmission time

- a) A manually operated HAND HELD TRANSMITTER shall employ a switch that will automatically deactivate the HAND HELD TRANSMITTER within not more than 5 seconds of being released.
- b) A HAND HELD TRANSMITTER activated automatically shall cease transmission within 5 seconds after activation.

2.4 Labeling Requirement

The device shall bear the following statement in a conspicuous location on the device :

This device complies with part 15 of the FCC Rules. Operation is subject to the following two conditions: (1) This device may not cause harmful interference, and (2) this device must accept any interference received, including interference that may cause undesired operation.

2.5 User Information

The users manual or instruction manual for an intentional or unintentional radiator shall caution the user that changes or modifications not expressly approved by the party responsible for compliance could void the user's authority to operate the equipment.

3. RADIATED EMISSION MEASUREMENT

3.1 Applicable Standard

For periodic operation intentional radiator, the radiated emission shall comply with § 15.231(b).

3.2 Measurement Procedure

1. Setup the configuration per figure 1 and 2 for frequencies measured below and above 1 GHz respectively. Turn on EUT and make sure that it is in normal function.
2. For emission frequencies measured below 1 GHz, a pre-scan is performed in a shielded chamber to determine the accurate frequencies of higher emissions will be checked on a open test site. As the same purpose, for emission frequencies measured above 1 GHz, a pre-scan also be performed with a 1 meter measuring distance before final test.
3. For emission frequencies measured below and above 1 GHz, set the spectrum analyzer on a 100 kHz and 1 MHz resolution bandwidth respectively for each frequency measured in step 2.
4. The search antenna is to be raised and lowered over a range from 1 to 4 meters in horizontally polarized orientation. Position the highness when the highest value is indicated on spectrum analyzer, then change the orientation of EUT on test table over a range from 0 ° to 360 ° with a speed as slow as possible, and keep the azimuth that highest emission is indicated on the spectrum analyzer. Vary the antenna position again and record the highest value as a final reading. A RF test receiver is also used to confirm emissions measured.
5. Repeat step 4 until all frequencies need to be measured were complete.
6. Repeat step 5 with search antenna in vertical polarized orientations.
7. Check the three frequencies of highest emission with varying the placement of cables (if any) associated with EUT to obtain the worse case and record the result.

Figure 1 : Frequencies measured below 1 GHz configuration

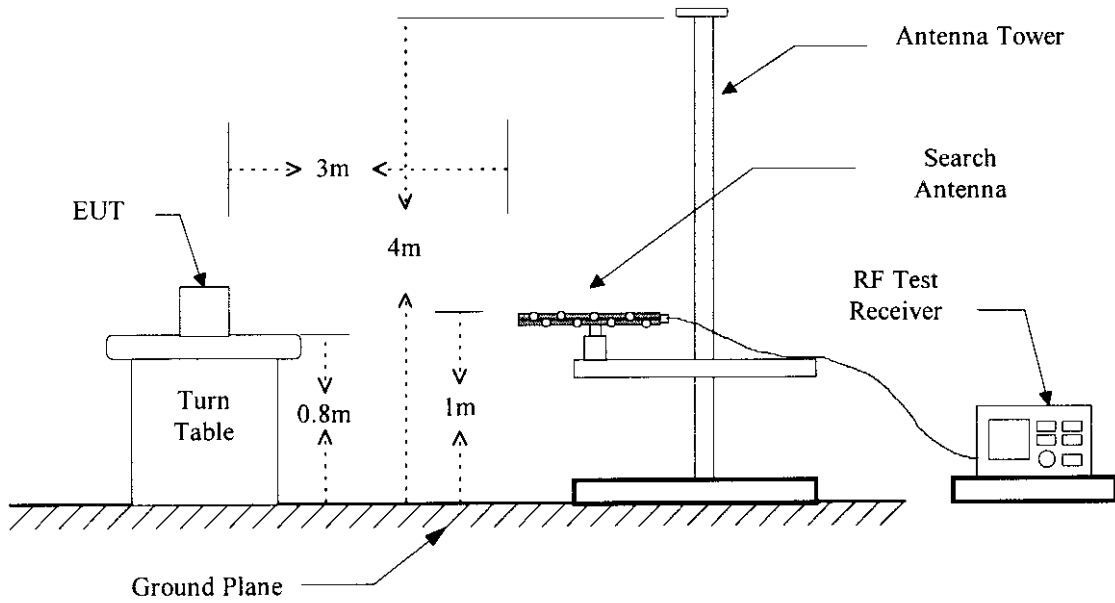
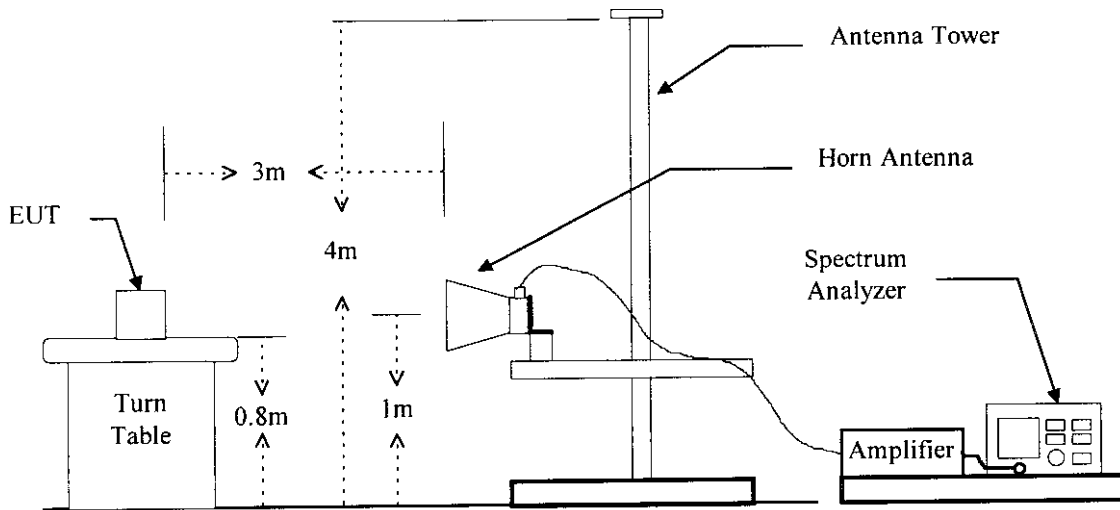

Figure 2 : Frequencies measured above 1 GHz configuration



3.3 Test Data

Temperature : 32 °C
 Humidity : 38 %
 Operated mode : Transmitting
 Test Date : JUL. 16, 1998

| Frequency (MHz) | Ant Pol H/V | Reading (dBuV) Peak | Factor (dB) | | Result @3m (dBuV/m) | | Limit @3m (dBuV/m) | | Margin (dB) | Table Degree (Deg.) | Ant. High (m) |
|--------------------|-------------------|---------------------------|----------------|-------|------------------------|------|-----------------------|------|----------------|---------------------------|---------------------|
| | | | C | D | Peak | Ave. | Peak | Ave. | | | |
| 418.000 | H | 84.1 | -5.8 | -14.7 | 78.3 | 63.6 | 100.3 | 80.3 | -16.7 | 285 | 1.00 |
| 836.000 | H | 43.2 | 1.8 | -14.7 | 45.0 | 30.3 | 80.3 | 60.3 | -30.0 | 249 | 1.00 |
| 1254.000 | V | 61.5 | -8.6 | -14.7 | 52.9 | 38.2 | 80.3 | 60.3 | -22.1 | 358 | 2.00 |
| *1672.000 | H | 58.2 | -6.5 | -14.7 | 51.7 | 37.0 | 74.0 | 54.0 | -17.0 | 92 | 2.00 |
| 2090.000 | V | 53.5 | -4.3 | -14.7 | 49.2 | 34.5 | 80.3 | 60.3 | -25.8 | 180 | 2.00 |
| 2508.000 | V | 54.2 | -2.7 | -14.7 | 51.5 | 36.8 | 80.3 | 60.3 | -23.5 | 180 | 1.10 |
| 2926.000 | H | 47.4 | -1.4 | -14.7 | 46.0 | 31.3 | 80.3 | 60.3 | -29.0 | 0 | 2.00 |
| 3344.000 | V | 48.4 | -0.4 | -14.7 | 48.0 | 33.3 | 80.3 | 60.3 | -27.0 | 90 | 2.00 |
| *3762.000 | H/V | --- | 1.0 | -14.7 | --- | --- | 74.0 | 54.0 | --- | --- | --- |
| *4180.000 | H/V | --- | 2.0 | -14.7 | --- | --- | 74.0 | 54.0 | --- | --- | --- |

Note :

1. Factor C means "corrected", and that includes antenna factor, cable loss, amplifier gain (if any). And Factor D means "Duty", that is for calculating the average value and derived from section 3.6 in this test report.
2. Result = Reading + C. Factor
Ave. = Peak Value + D Factor
3. The limit for spurious emissions is referred to FCC class B.

If the measured frequencies fall in the restricted frequency band, the limit employed is § 15.209 general requirement when frequencies are below or equal to 1 GHz. And the measuring instrument is set to quasi peak detector function, no duty factor applied.

3.4 Field Strength Calculation

The field strength is calculated by adding the Antenna Factor and Cable Factor, and subtracting the Amplifier Gain (if any) from the measured reading. For the limit is employed average value, therefore the peak value can be transferred to average value by subtracting the duty factor. The basic equation with a sample calculation is as follows:

$$\mathbf{Peak = Reading + Corrected Factor}$$

where

Corr. Factor = Antenna Factor + Cable Factor - Amplifier Gain (if any)

And the average value is

$$\mathbf{Average = Peak Value + Duty Factor}$$

Note : If the measured frequencies are fall in the restricted frequency band, the limit employed must be quasi peak value when frequencies are below or equal to 1 GHz. And the measuring instrument is set to quasi peak detector function.

3.5 Activate Time

This HAND HELD TRANSMITTER is operated by Manual, and Activate Time is less than 5 second after being released.

3.6 Calculation of Duty Factor

The total period of pulse train is 98.6 ms, and the total duty is 18.2 ms, and the duty factor is calculated with following formula :

$$20 \log \frac{\text{Total Duty}}{\text{Period of Pulse Train}} = -14.7 \text{ (dB)}$$

Details please see following two plotted pages.

a. Full Cycle of The Pulse Train

$$20\log\left|\frac{(4 \times 1.1\text{ms}) + (23 \times 0.571\text{ms}) + (2 \times 0.343\text{ms})}{98.6\text{ms}}\right| = 20\log\left|\frac{18.2\text{ms}}{98.6\text{ms}}\right| = -14.7 \text{ (dB)}$$

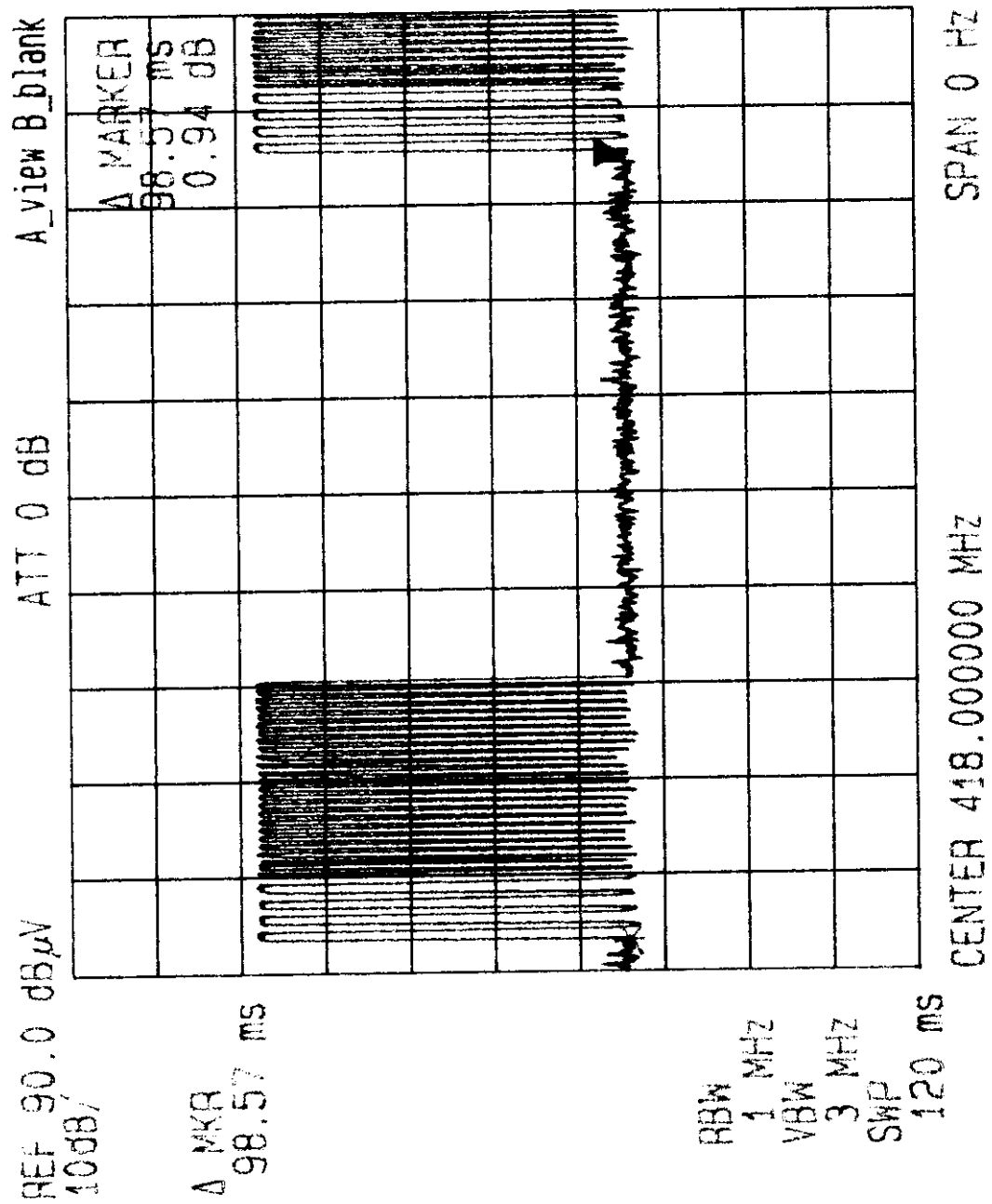

b. Detail of The Pulse Train

b1.

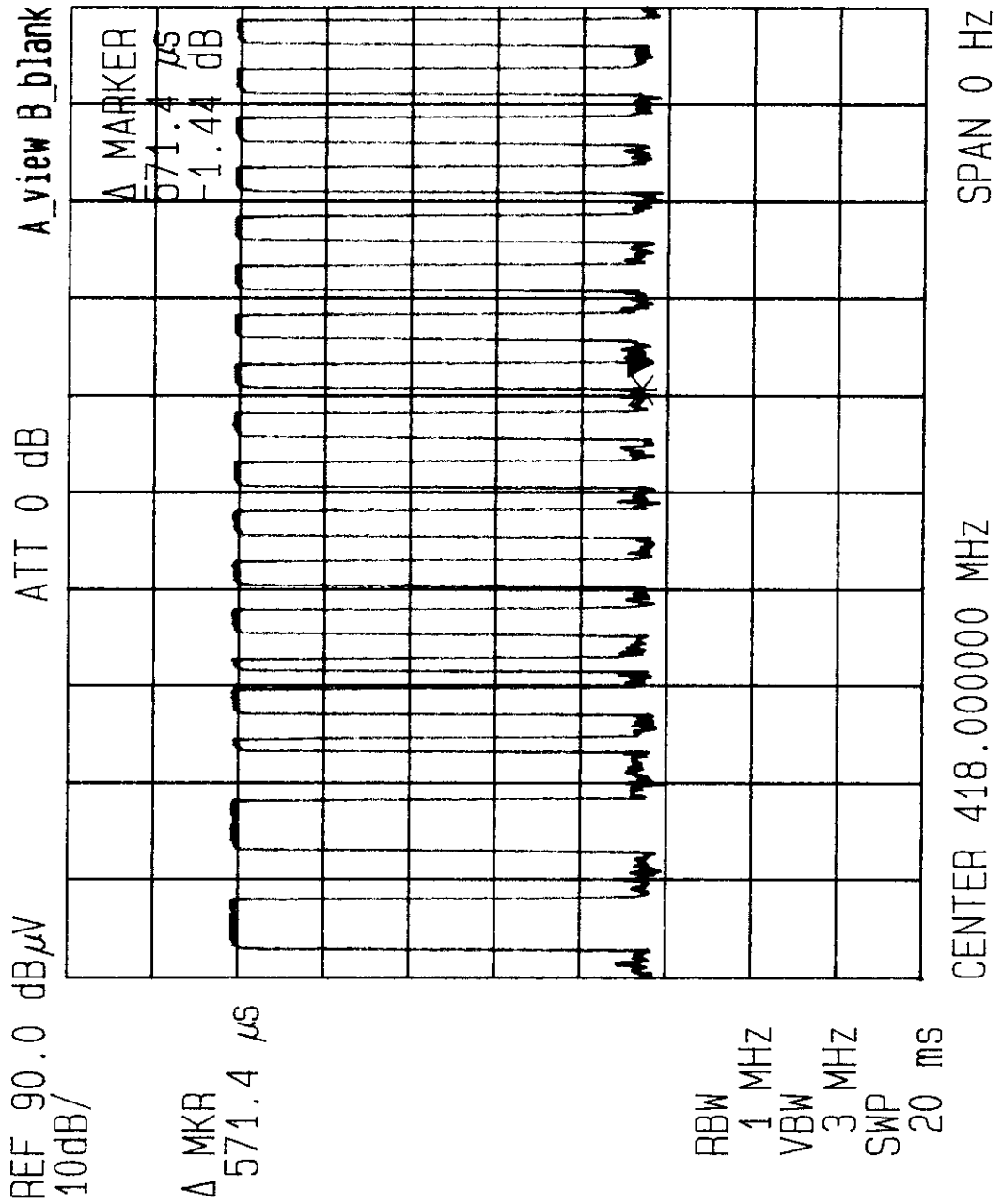

b2.

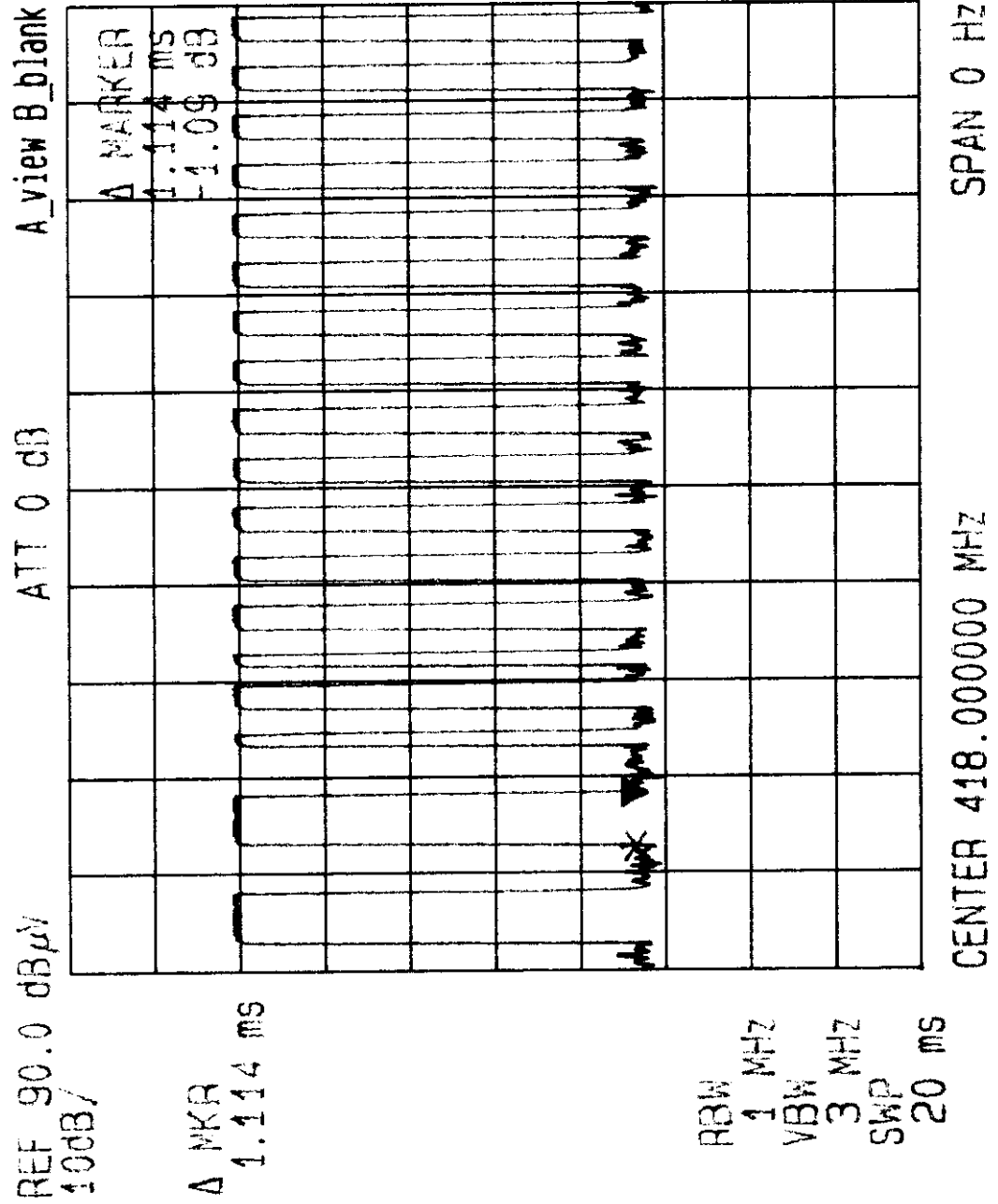

3.7 Radiated Test Equipment

| Equipment | Manufacturer | Model No. | Next Cal. Date |
|----------------------|-----------------|-----------|----------------|
| Spectrum Analyzer | Hewlett-Packard | 8568B | 10/16/1998 |
| Pre-selector | Hewlett-Packard | 85685A | 10/16/1998 |
| Quasi Peak Detector | Hewlett-Packard | 85650A | 10/07/1998 |
| Spectrum Analyzer | Adventest | R3271 | 09/02/1998 |
| RF Test Receiver | Rohde & Schwarz | ESVS 30 | 12/10/1998 |
| Horn Antenna | EMCO | 3115 | 08/05/1998 |
| Log periodic Antenna | EMCO | 3146 | 08/05/1998 |
| Biconical Antenna | EMCO | 3110 | 08/05/1998 |
| Preamplifier | Hewlett-Packard | 8449B | 05/08/1999 |
| Preamplifier | Hewlett-Packard | 8447D | 12/23/1998 |

3.8 Measuring Instrument Setup

Explanation of measuring instrument setup in frequency band measured is as following :

| Frequency Band (MHz) | Instrument | Function | Resolution bandwidth | Video Bandwidth |
|----------------------|-------------------|------------|----------------------|-----------------|
| 30 to 1000 | RF Test Receiver | Quasi Peak | 120 kHz | N/A |
| | Spectrum Analyzer | Peak | 100 kHz | 100 kHz |
| Above 1000 | Spectrum Analyzer | Peak | 1 MHz | 1 MHz |

4. BANDWIDTH OF EMISSION

4.1 Applicable Standard Plot Graphic of Bandwidth

Per FCC rule § 15.231(c), the permitted emission bandwidth is no wider than 0.25% of the center frequency for devices operating above 70 MHz and below 900 MHz.

4.2 Bandwidth Test Equipment

| Equipment | Manufacturer | Model No. | Next Cal. Date |
|-------------------|-----------------|-----------|----------------|
| Spectrum Analyzer | Adventest | R3271 | 09/02/1998 |
| Plotter | Hewlett-Packard | 7440A | N/A |
| | | | |

4.3 Plot Graphic of Bandwidth

The emission bandwidth for this transmitter is

$$418.0 \times 0.25\% = 1045 \text{ KHz}$$

Plotted graphics please see following page.

Emission Bandwidth

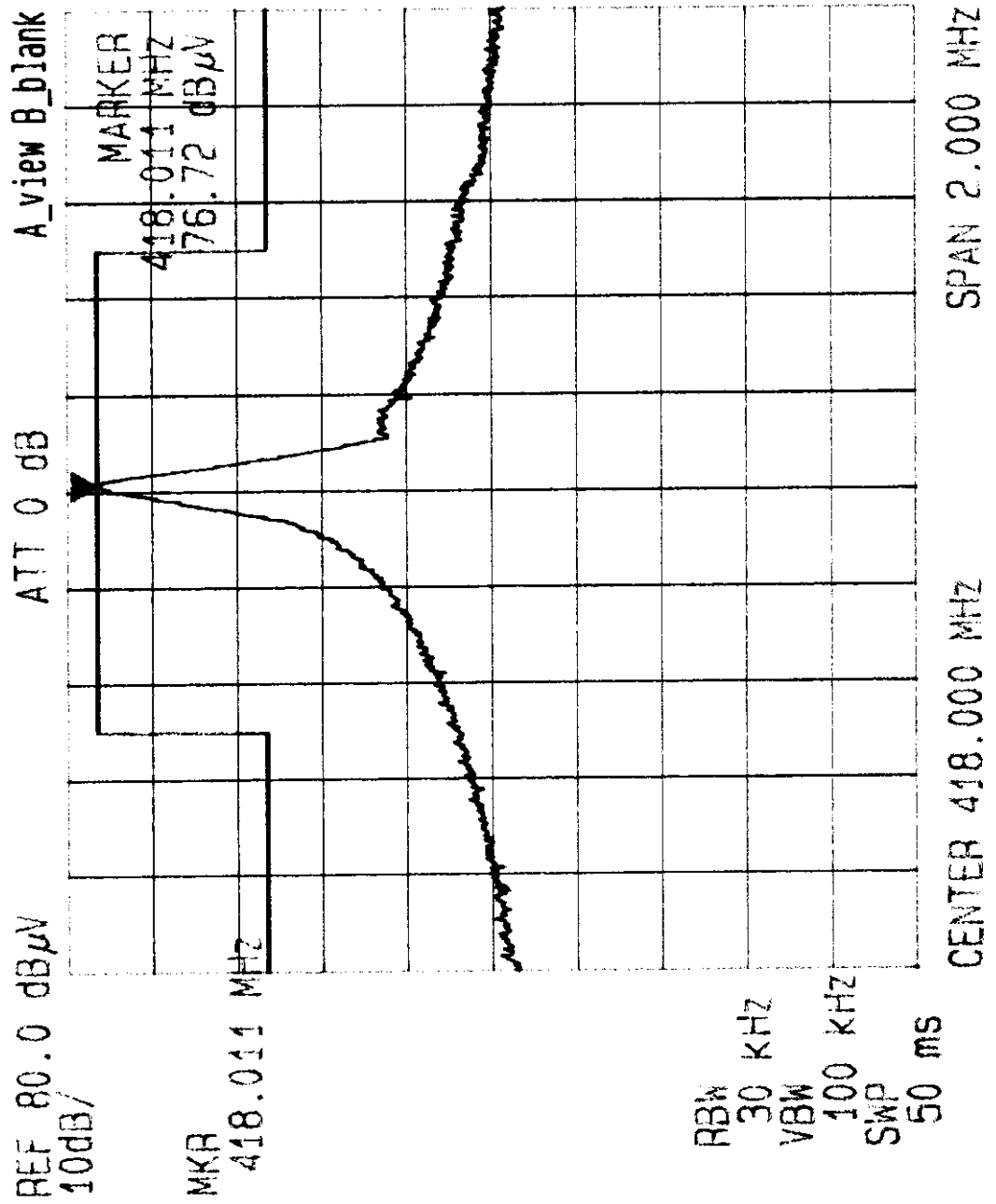

5. CONDUCTED EMISSION MEASUREMENT

5.1 Standard Applicable

This EUT is excused from investigation of conducted emission, for it is powered by battery only. According to § 15.107 (d), measurements to demonstrate compliance with the conducted limits are not required for devices which only employ battery power for operation and which do not operate from the AC power lines or contain provisions for operation while connected to the AC power lines.