

LABEL

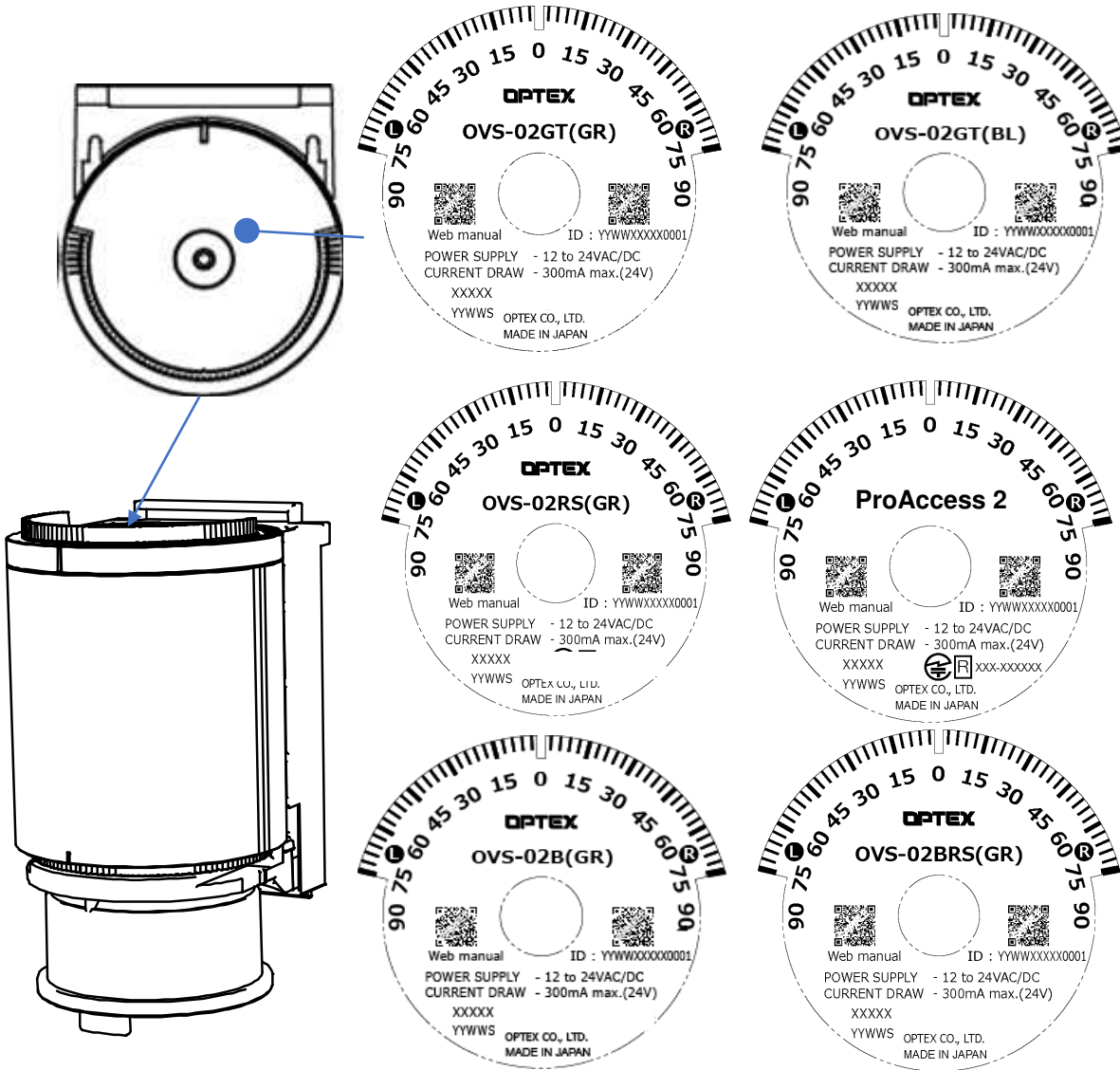

※The label shown is permanently affixed and readily visible to the user.
(Permanent adhesive of Acrylic adhesive is used.)
The installer can recognize this label when wiring.
(Labeling requirement per 2.925)

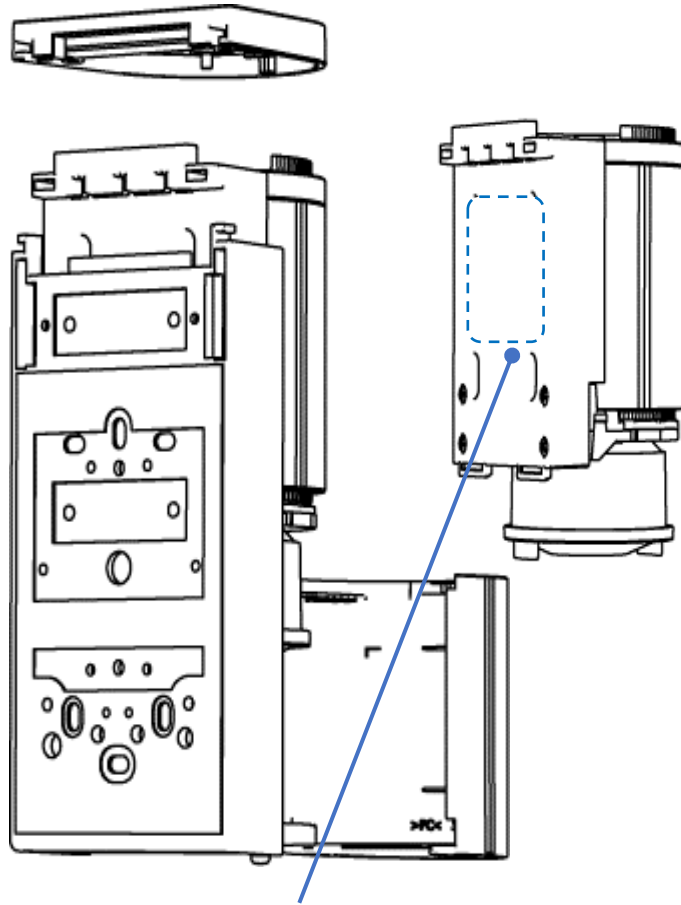

FCC ID:DC9-OVS02 IC:4012A-OVS02
Contains FCC ID:RYYEYSHJN
Contains IC: 4389B-EYSHJN
CAN ICES-3(B)/NMB-3(B)

This device complies with Part 15 of the FCC Rules, and Innovation, Science and Economic Development Canada's licence-exempt RSS(s).
Operation is subject to the following two conditions : (1) this device maynot cause harmful interference, and (2) this device must accept any interference received, including interference that may cause undesired operation.

※The label shown is permanently affixed and readily visible to the user.
(Permanent adhesive of Acrylic adhesive is used.)
The instoller can recognize this label when wiring.
(Labeling requirement per 2.925)

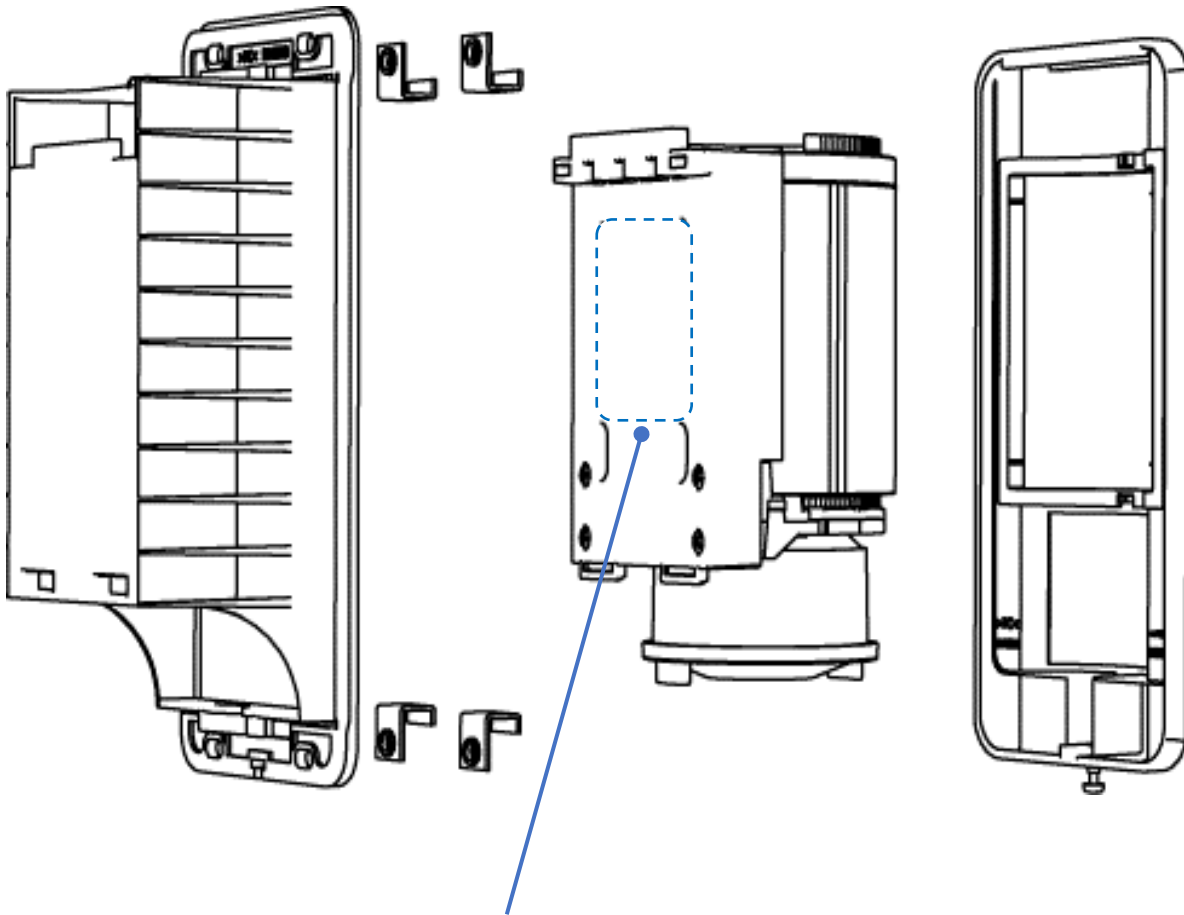

FCC ID:DC9-OVS02 IC:4012A-OVS02
Contains FCC ID:RYYEYSHJN
Contains IC: 4389B-EYSHJN
CAN ICES-3(B)/NMB-3(B)

This device complies with Part 15 of the FCC Rules and Innovation, Science and Economic Development Canada's licence-exempt RSS(s).
Operation is subject to the following two conditions : (1) this device maynot cause harmful interference, and (2) this device must accept any interference received, including interference that may cause undesired operation.

※The label shown is permanently affixed and readily visible to the user.
(Permanent adhesive of Acrylic adhesive is used.)
The instoller can recognize this label when wiring.
(Labeling requirement per 2.925)