**CETECOM™****CETECOM ICT Services**
consulting - testing - certification >>>

TEST REPORT

Test report no.: 1-6783/13-01-02



Testing laboratory

CETECOM ICT Services GmbH
Untertuerkheimer Strasse 6 – 10
66117 Saarbruecken / Germany
Phone: + 49 681 5 98 - 0
Fax: + 49 681 5 98 - 9075
Internet: <http://www.cetecom.com>
e-mail: ict@cetecom.com**Accredited Testing Laboratory:**The testing laboratory (area of testing) is accredited according to DIN EN ISO/IEC 17025 (2005) by the Deutsche Akkreditierungsstelle GmbH (DAkkS). The accreditation is valid for the scope of testing procedures as stated in the accreditation certificate with the registration number: D-PL-12076-01-01
Area of Testing:
Radio Communications & Compatibility Testing (RCT)

Applicant

InnoSenT GmbH
Am Rödertor 30
97499 Donnersdorf / GERMANY
Phone: +49 95 28 95 18 0
Fax: +49 95 28 95 18 18 76
Contact: Christian Düring
e-mail: christian.duering@innosent.de
Phone: +49 95 28 95 18 76

Manufacturer

InnoSenT GmbH
Am Rödertor 30
97499 Donnersdorf / GERMANY

Test standard/s

47 CFR 15	Title 47 of the Code of Federal Regulations; Chapter I Part 15 - Radio frequency devices
RSS - 210 Issue 8	Spectrum Management and Telecommunications - Radio Standards Specification Low-power Licence-exempt Radiocommunication Devices (All Frequency Bands): Category I Equipment

For further applied test standards please refer to section 3 of this test report.

Test Item

Kind of test item:	K-Band VCO Transceiver
Model name:	IVS-166
FCC ID:	DC9-IVS166
IC:	4012A-IVS166
Frequency:	24.075 GHz – 24.175 GHz
Antenna:	Integrated patch antenna
Power supply:	5 V DC (Vcc) from Power Supply 5 V DC (Vtune) from Power Supply
Temperature range:	-20°C to +55°C



This test report is electronically signed and valid without handwriting signature. For verification of the electronic signatures, the public keys can be requested at the testing laboratory.

Test report authorised:2013-12-17 Karsten Gerald
Senior Testing Manager**Test performed:**2013-12-17 Meheza Walla
Expert

1 Table of contents

1	Table of contents	2
2	General information	3
2.1	Notes and disclaimer	3
2.2	Application details	3
3	Test standard/s	3
4	Test environment	4
5	Test item	4
6	Test laboratories sub-contracted	4
7	Summary of measurement results	5
8	RF measurement testing	6
8.1	Description of test setup	6
8.1.1	Radiated measurements	6
8.1.2	Additional comments	7
9	Measurement results	8
9.1	Field strength of emissions (wanted signal)	8
9.2	Occupied bandwidth (99% bandwidth)	10
9.3	Field strength of emissions (radiated spurious)	12
9.4	Conducted spurious emissions < 30 MHz	20
10	Test equipment and ancillaries used for tests	22
11	Observations	23
Annex A	Photographs of the test setup	24
Annex B	Photographs of the EUT	26
Annex C	Document history	28
Annex D	Further information	28
Annex E	Accreditation Certificate	29

2 General information

2.1 Notes and disclaimer

The test results of this test report relate exclusively to the test item specified in this test report. CETECOM ICT Services GmbH does not assume responsibility for any conclusions and generalizations drawn from the test results with regard to other specimens or samples of the type of the equipment represented by the test item.

The test report may only be reproduced or published in full. Reproduction or publication of extracts from the report requires the prior written approval of CETECOM ICT Services GmbH.

The testing service provided by CETECOM ICT Services GmbH has been rendered under the current "General Terms and Conditions for CETECOM ICT Services GmbH".

CETECOM ICT Services GmbH will not be liable for any loss or damage resulting from false, inaccurate, inappropriate or incomplete product information provided by the customer.

Under no circumstances does the CETECOM ICT Services GmbH test report include any endorsement or warranty regarding the functionality, quality or performance of any other product or service provided.

Under no circumstances does the CETECOM ICT Services GmbH test report include or imply any product or service warranties from CETECOM ICT Services GmbH, including, without limitation, any implied warranties of merchantability, fitness for purpose, or non-infringement, all of which are expressly disclaimed by CETECOM ICT Services GmbH.

All rights and remedies regarding vendor's products and services for which CETECOM ICT Services GmbH has prepared this test report shall be provided by the party offering such products or services and not by CETECOM ICT Services GmbH.

In no case this test report can be considered as a Letter of Approval.

This test report is electronically signed and valid without handwritten signature. For verification of the electronic signatures, the public keys can be requested at the testing laboratory.

2.2 Application details

Date of receipt of order:	2013-09-26
Date of receipt of test item:	2013-10-04
Start of test:	2013-10-14
End of test:	2013-10-16
Person(s) present during the test:	-/-

3 Test standard/s

Test standard	Date	Test standard description
47 CFR 15	2010-10	Title 47 of the Code of Federal Regulations; Chapter I Part 15 - Radio frequency devices
RSS - 210 Issue 8	2010-12	Spectrum Management and Telecommunications - Radio Standards Specification Low-power Licence-exempt Radiocommunication Devices (All Frequency Bands): Category I Equipment

4 Test environment

Temperature:	T_{nom}	+22 °C during room temperature tests
Relative humidity content:		55 %
Barometric pressure:		not relevant for this kind of testing
Power supply:	V_{nom}	12 V DC from Power Supply

5 Test item

Kind of test item	:	K-Band VCO Transceiver
Type identification	:	IVS-166
S/N serial number	:	166000034 166000035
HW hardware status	:	-/-
SW software status	:	-/-
Frequency band [MHz]	:	24.075 GHz – 24.175 GHz
Type of modulation	:	N0N
Number of channels	:	1
Antenna	:	Integrated patch antenna
Power supply	:	5 V DC from power supply
Temperature range	:	+22°C (Tests made under nominal temperature)

6 Test laboratories sub-contracted

None

7 Summary of measurement results

- No deviations from the technical specifications were ascertained**
- There were deviations from the technical specifications ascertained

TC Identifier	Description	Verdict	Date	Remark
RF-Testing	47 CFR Part 15 RSS 210, Issue 8, Annex 7	Passed	2013-12-17	-/-

Test specification clause	Test case	Temperature conditions	Power source voltages	Pass	Fail	NA	NP	Results (max.)
§15.245(b) RSS 210 / A7.1	Field strength of emissions (wanted signal)	Nominal	Nominal	<input checked="" type="checkbox"/>	<input type="checkbox"/>	<input type="checkbox"/>	<input type="checkbox"/>	113 dBµV
§2.1049	Occupied bandwidth (99% bandwidth)	Nominal	Nominal	<input checked="" type="checkbox"/>	<input type="checkbox"/>	<input type="checkbox"/>	<input type="checkbox"/>	237 kHz
§15.209(a) / §15.245(b)(1)(2)(3) RSS 210 / A7.1-4	Field strength of emissions (spurious)	Nominal	Nominal	<input checked="" type="checkbox"/>	<input type="checkbox"/>	<input type="checkbox"/>	<input type="checkbox"/>	complies
§15.207(a) ICES-003	Conducted emissions < 30 MHz	Nominal	Nominal	<input checked="" type="checkbox"/>	<input type="checkbox"/>	<input type="checkbox"/>	<input type="checkbox"/>	complies

Note: NA = Not Applicable; NP = Not Performed

8 RF measurement testing

8.1 Description of test setup

8.1.1 Radiated measurements

The radiated measurements are performed in vertical and horizontal plane in the frequency range from 9 kHz to 25 GHz in semi-anechoic chambers. The EUT is positioned on a non-conductive support with a height of 0.80 m above a conductive ground plane that covers the whole chamber. The receiving antennas are confirmed with specifications ANSI C63.2-1996 clause 15 and ANSI C63.4-2009 clause 4.1.5. These antennas can be moved over the height range between 1.0 m and 4.0 m in order to search for maximum field strength emitted from EUT. The measurement distances between EUT and receiving antennas are indicated in the test setups for the various frequency ranges. For each measurement, the EUT is rotated in all three axes until the maximum field strength is received. The wanted and unwanted emissions are received by spectrum analyzers where the detector modes and resolution bandwidths over various frequency ranges are set according to requirement ANSI C63-4-2009 clause 4.2.

Antennas are confirmed with ANSI C63.2-1996 item 15.

Semi anechoic chamber

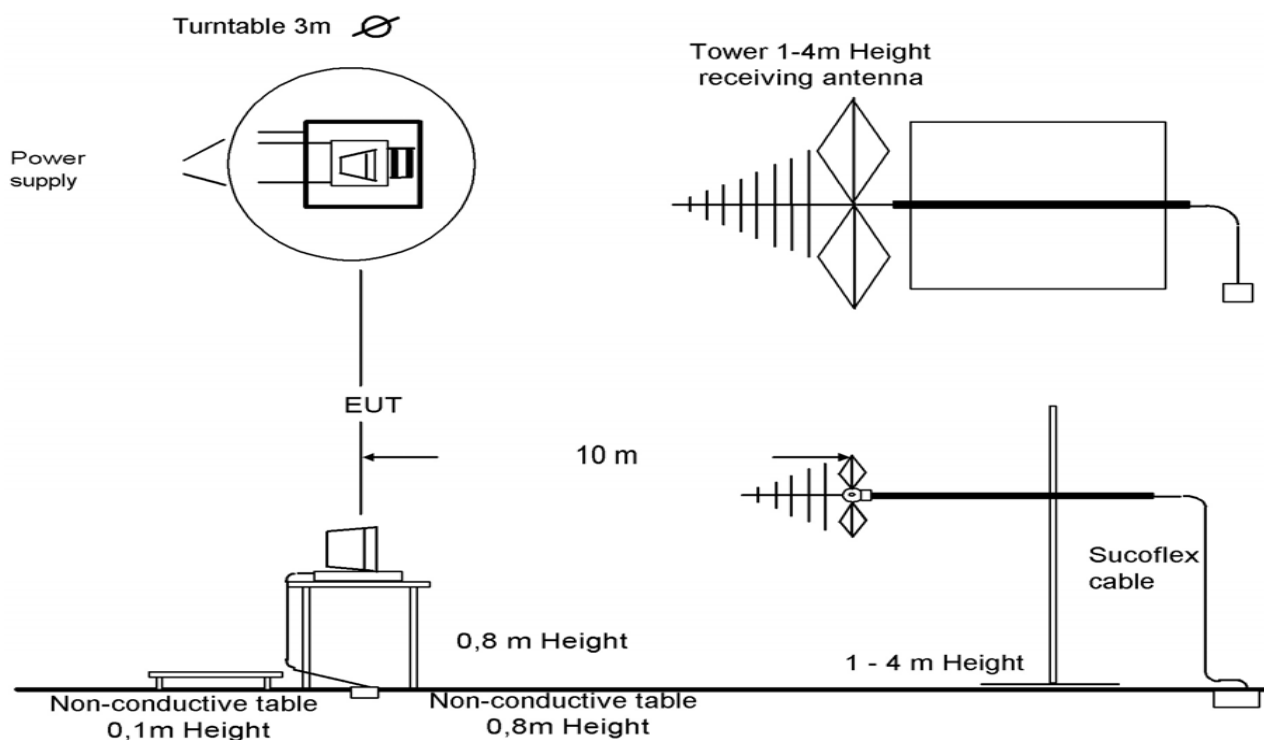

Picture 1: Diagram radiated measurements (30 MHz – 12 GHz)

9 kHz - 30 MHz:	active loop antenna
30 MHz – 1 GHz:	tri-log antenna
> 1 GHz:	horn antenna

The EUT is powered by an external power supply with nominal voltage

Test set-up for the measurement of spurious radiation and EIRP in the frequency range 12 GHz to 50 GHz:

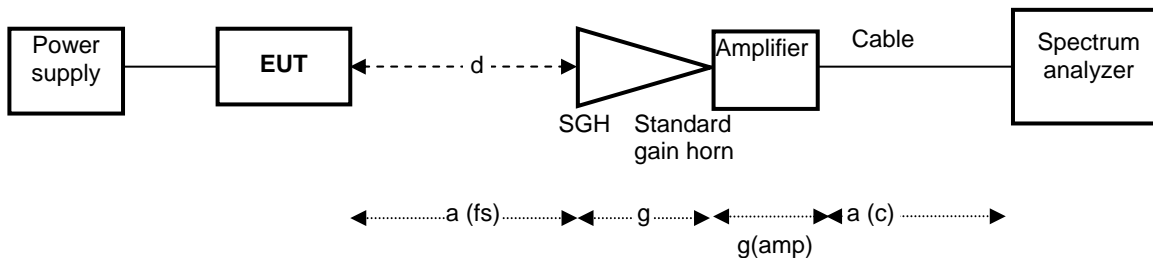

Picture 2: Diagram radiated measurements (12 GHz – 50 GHz)

Test set-up for the measurement of spurious radiation in the frequency range 50 GHz to 110 GHz:

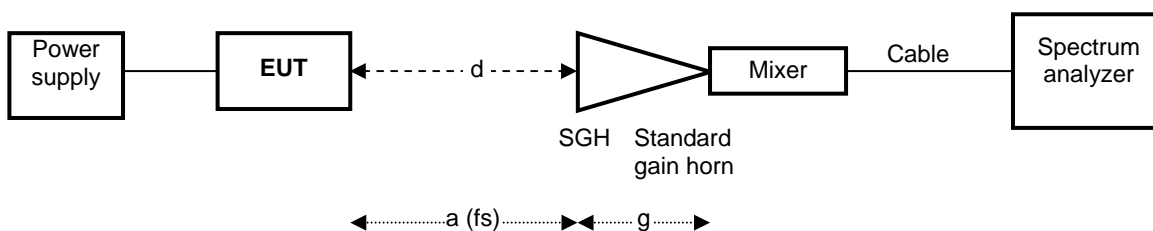

Picture 3: Diagram radiated measurements (50 GHz – 110 GHz)

8.1.2 Additional comments

Reference documents: None

Special test descriptions: None

Configuration descriptions: None

Test mode: Normal operation, no special test mode available.

Special software is used.

9 Measurement results

9.1 Field strength of emissions (wanted signal)

Description:

Measurement of the maximum radiated field strength of the wanted signal.

Measurement:

Measurement parameter	
Detector:	Pos-Peak
Sweep time:	Auto
Video bandwidth:	1 MHz
Resolution bandwidth:	3 MHz
Span:	10 MHz
Trace-Mode:	Max Hold

Plot 1: T_{nom} / V_{nom}

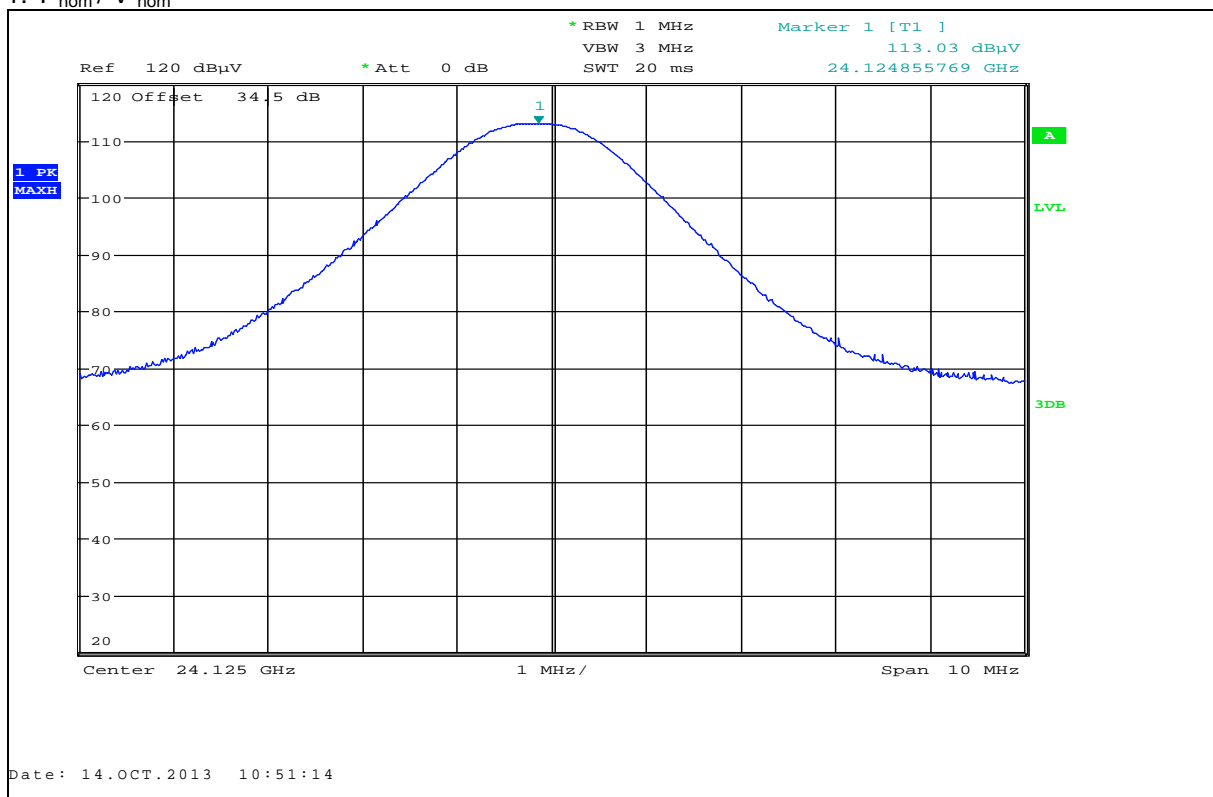

Result:

Test condition	Maximum field strength [dB μ V/m @ 3 m]
T _{nom} / V _{nom}	113.03
Measurement uncertainty	± 3 dB

Limits:

FCC	IC	
CFR Part 15.245(b)	RSS - 210, Annex 7	
Field strength of emissions		
The field strength of emissions from intentional radiators operated within these frequency bands shall comply with the following:		
Frequency [GHz]	Field Strength [dB μ V/m]	Measurement distance
24.075 – 24.175	128	3

Result: The measurement is passed.

9.2 Occupied bandwidth (99% bandwidth)

Description:

Measurement of the 99% bandwidth of the wanted signal.

Measurement:

Measurement parameter	
Detector:	Peak
Sweep time:	Auto
Video bandwidth:	Auto
Resolution bandwidth:	5 kHz
Span:	500 kHz
Trace-Mode:	Max Hold

Plot 2: 99% Bandwidth, T_{nom} / V_{nom}

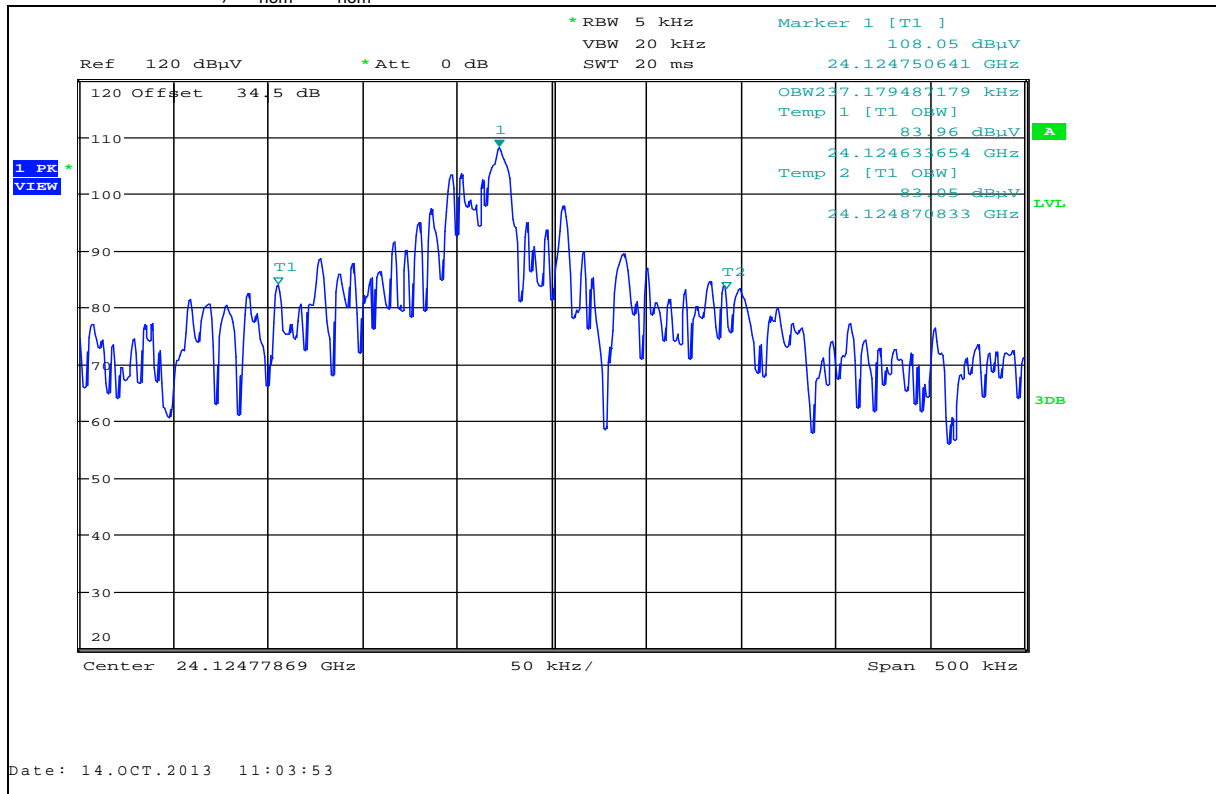

Result:

Test condition	99 % Occupied Bandwidth [kHz]
$T_{\text{nom}} / V_{\text{nom}}$	237.2
Measurement uncertainty	$\pm \text{span}/1000$

Result: The measurement is passed.

9.3 Field strength of emissions (radiated spurious)

Description:

Measurement of the radiated spurious emissions in transmit mode.

Measurement:

Measurement parameter	
Detector:	Peak / Quasi Peak
Sweep time:	Auto
Video bandwidth:	Auto
Resolution bandwidth:	F < 1 GHz: 100 kHz F > 1 GHz: 1 MHz
Frequency range:	30 MHz to 110 GHz
Trace-Mode:	Max Hold

Limits:

FCC		IC	
CFR Part 15.209(a)		RSS - GEN	
Radiated Spurious Emissions			
Emissions radiated outside of the specified frequency bands, except for harmonics, shall be attenuated by at least 50 dB below the level of the fundamental or to the general radiated emission limits in § 15.209, whichever is the lesser attenuation.			
Frequency (MHz)	Field Strength (dBµV/m)	Measurement distance	
0.009 – 0.490	2400/F(kHz)	300	
0.490 – 1.705	24000/F(kHz)	30	
1.705 – 30.0	30	30	
30 – 88	30.0	10	
88 – 216	33.5	10	
216 – 960	36.0	10	
Above 960	54.0	3	

Note: Harmonics shall not exceed 25.0 millivolts/meter (88.0 dBµV/m)

Result: The measurement is passed.

Plot 3: Traffic mode up to 30 MHz

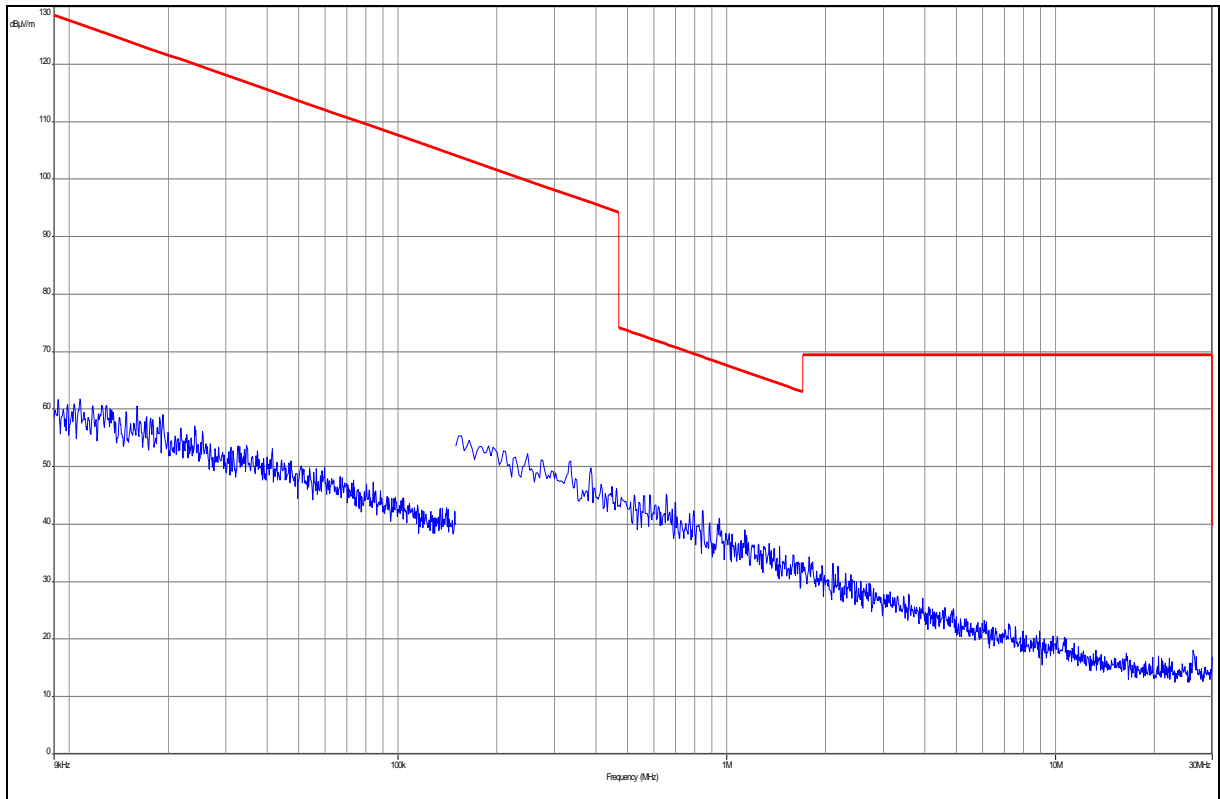

Plot 4: 30 MHz to 1 GHz, vertical / horizontal polarization

EUT:	IVS-166
Serial Number:	166000034
Test Description:	FCC Part 15 C class B @ 10 m
Operating Conditions:	TX-Mode
Operator Name:	Wolsdorfer
Comment:	5 V DC

Scan Setup: STAN_Fin [EMI radiated]

Hardware Setup:	Electric Field (NOS)
Receiver:	[ESCI 3]
Level Unit:	dBµV/m

Subrange	Step Size	Detectors	IF BW	Meas. Time	Preamp
30 MHz - 2 GHz	60 kHz	QPK	120 kHz	1 s	20 dB

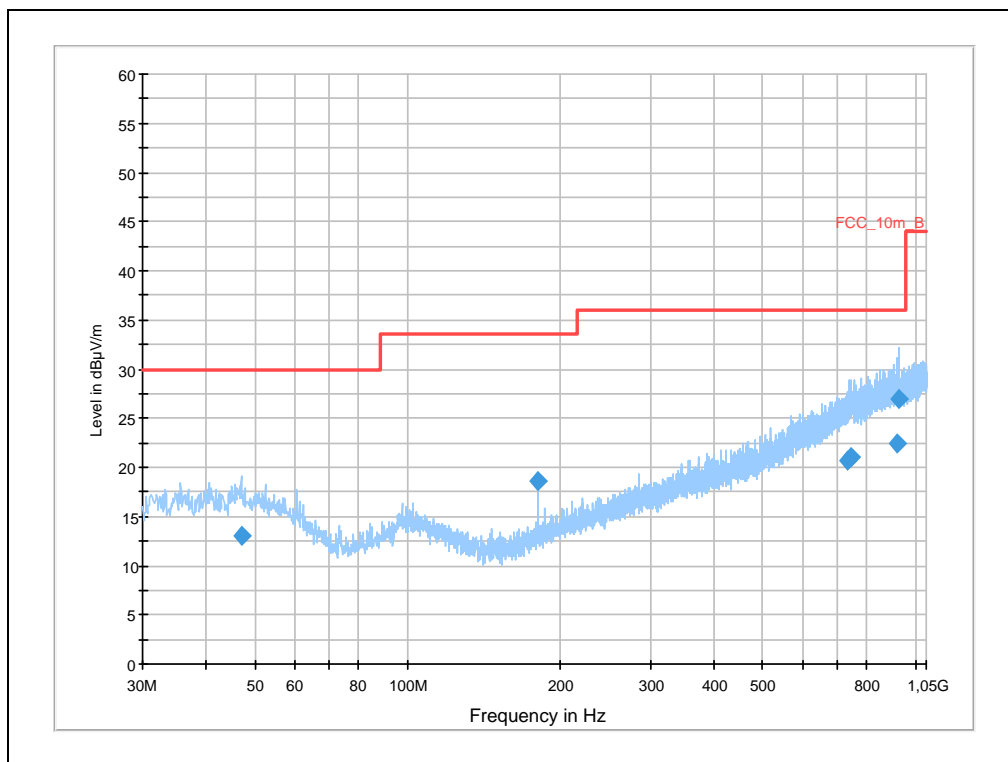

Frequency (MHz)	QuasiPeak (dBµV/m)	Meas. Time (ms)	Bandwidth (kHz)	Height (cm)	Polarization	Azimuth (deg)	Corr. (dB)	Margin (dB)	Limit (dBµV/m)
46.97685	13.1	1000.	120.000	205.0	V	140.0	13.3	16.9	30.0
179.99640	18.6	1000.	120.000	205.0	V	108.0	10.4	14.9	33.5
732.64440	20.7	1000.	120.000	385.0	H	140.0	23.3	15.3	36.0
745.01055	21.0	1000.	120.000	205.0	V	206.0	23.5	15.0	36.0
923.03700	22.5	1000.	120.000	385.0	H	265.0	25.3	13.5	36.0
927.49470	26.9	1000.	120.000	300.0	H	93.0	25.3	9.1	36.0

Plot 5: 1 GHz to 12 GHz, vertical / horizontal polarization

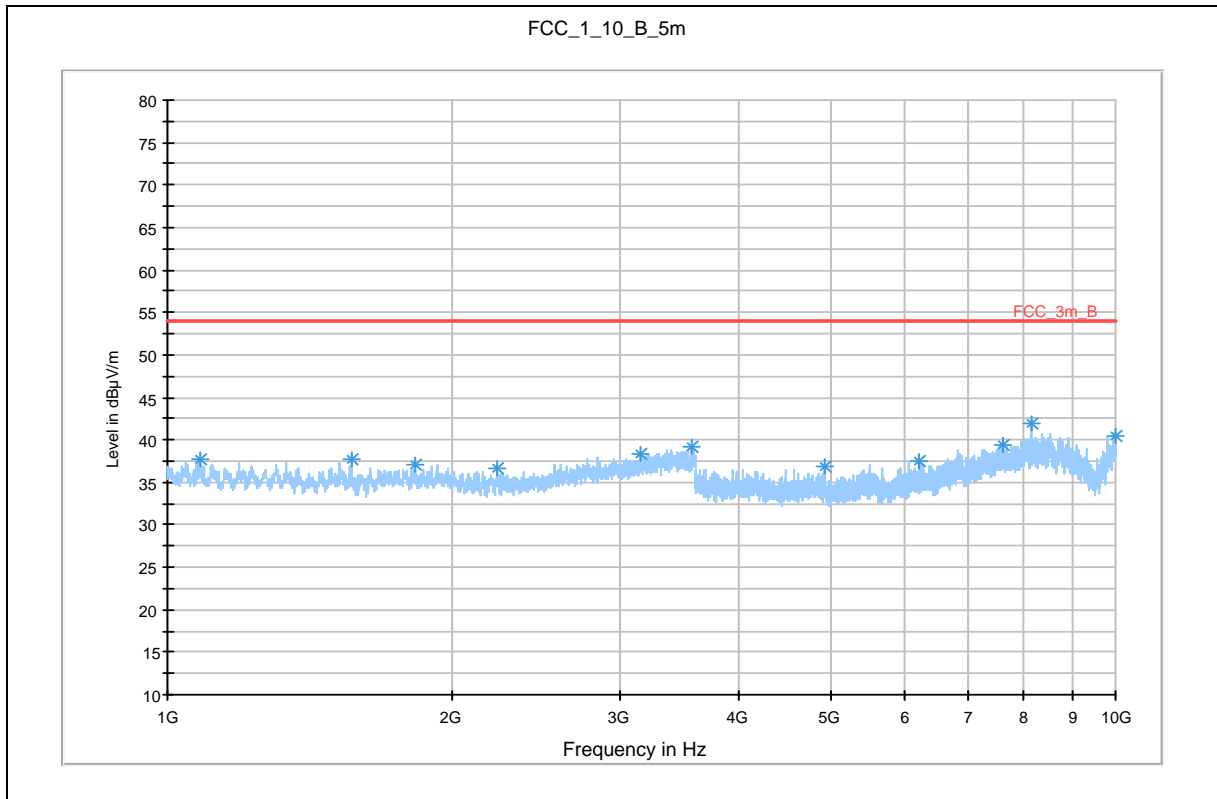

Plot 6: 12 GHz to 18 GHz, vertical / horizontal polarization

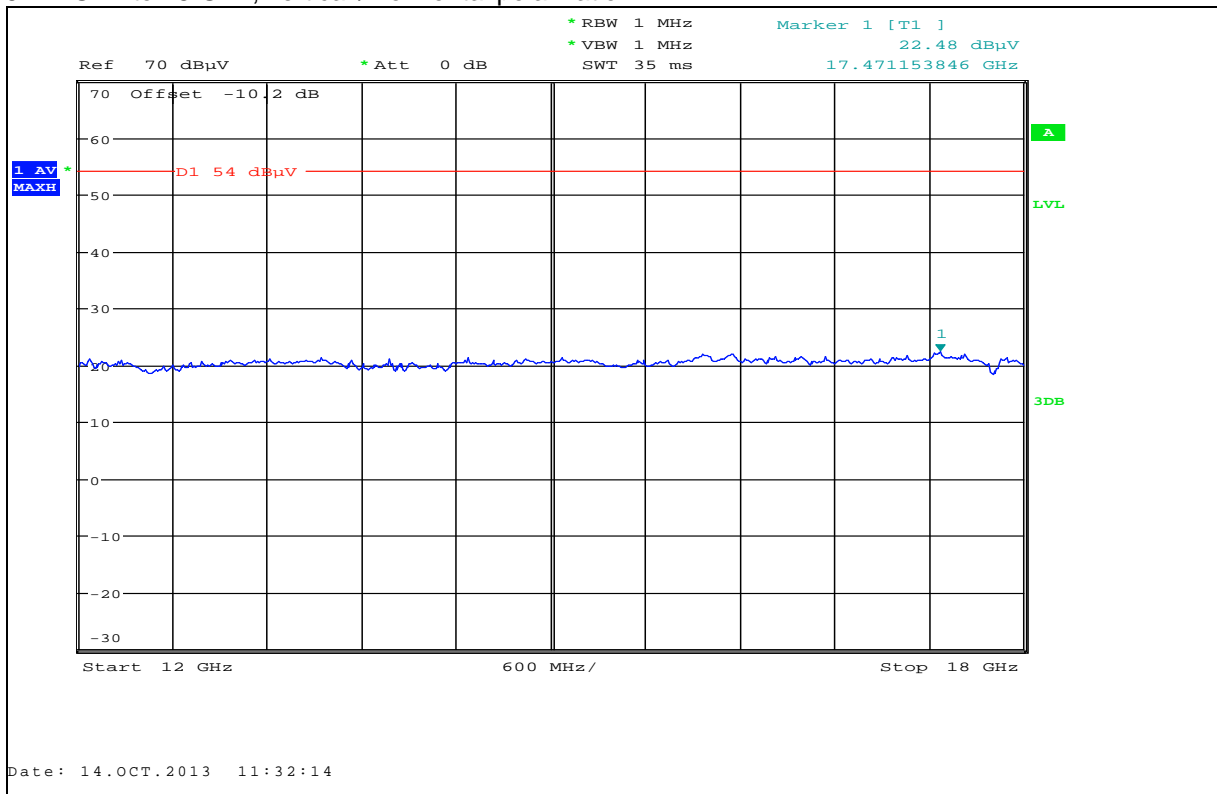

Plot 7: 18 GHz to 26 GHz, vertical / horizontal polarization

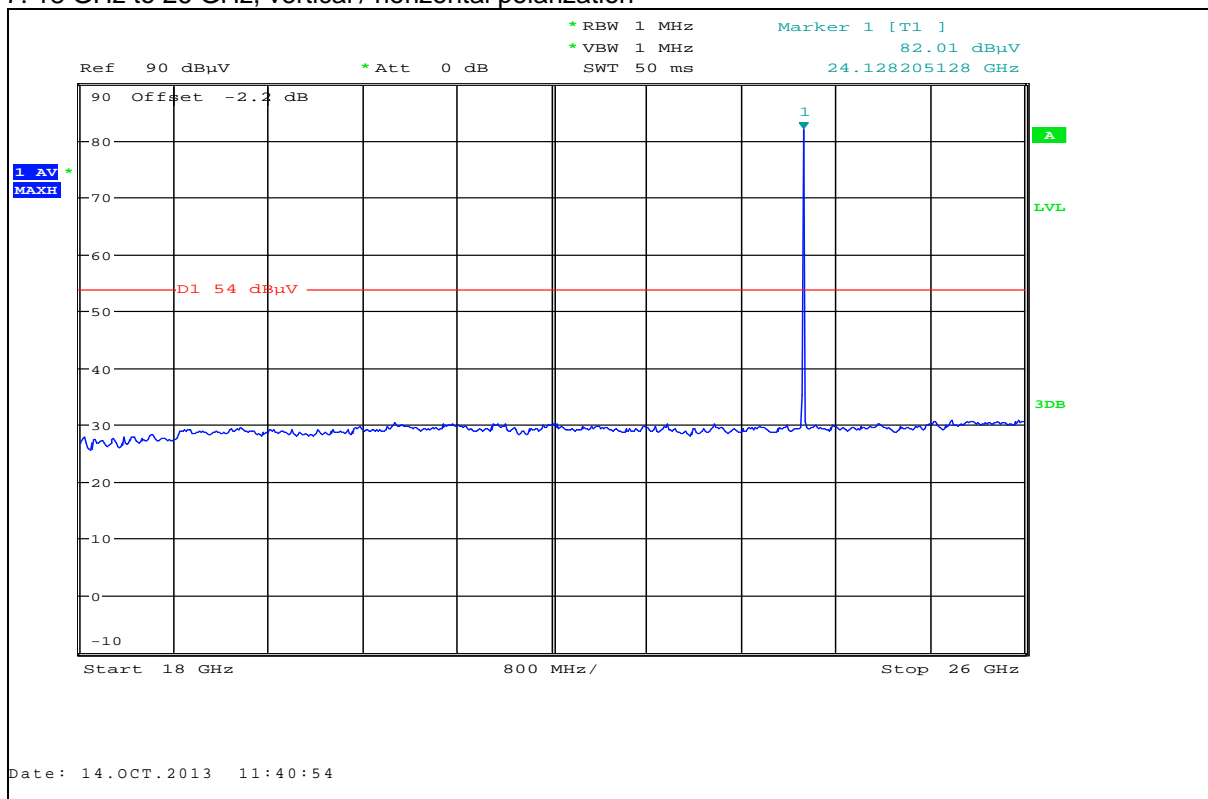

(Plot shows the carrier at 24 GHz)

Plot 8: 26 GHz to 40 GHz, horizontal / vertical polarization

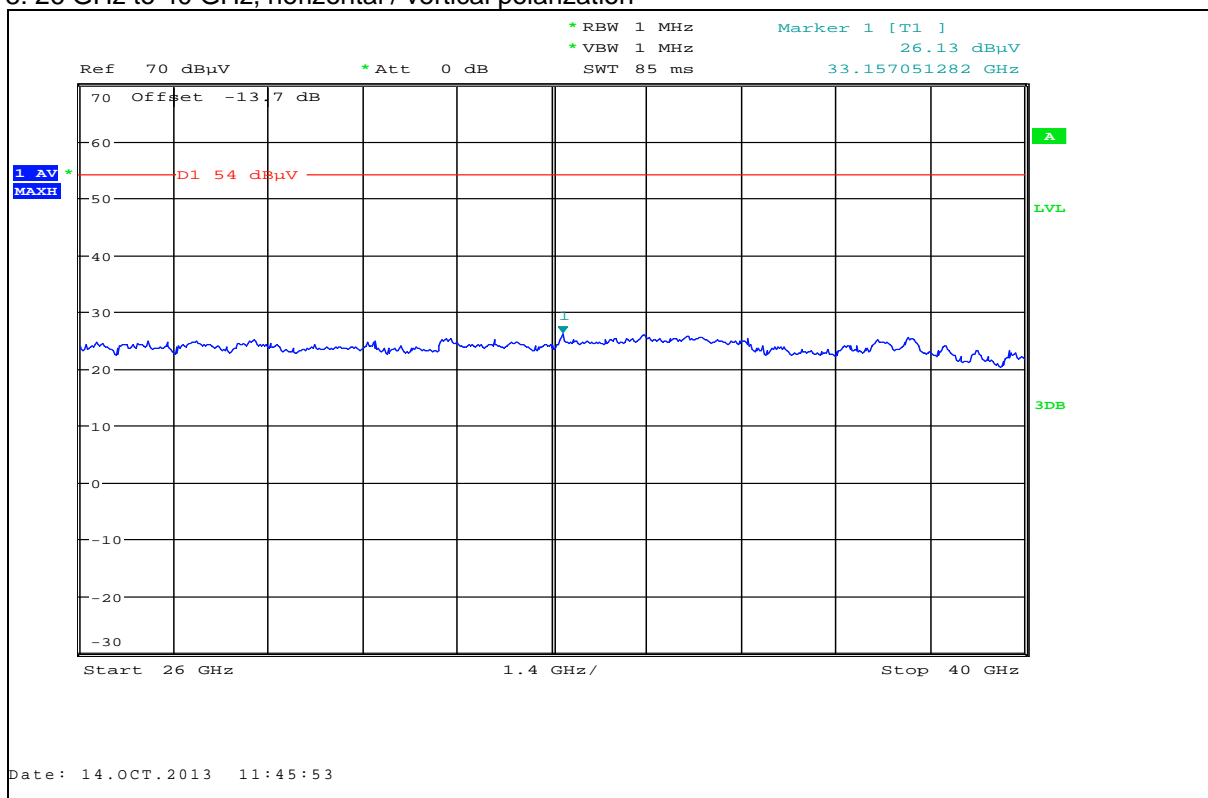

Plot 9: 40 GHz to 50 GHz, horizontal / vertical polarization

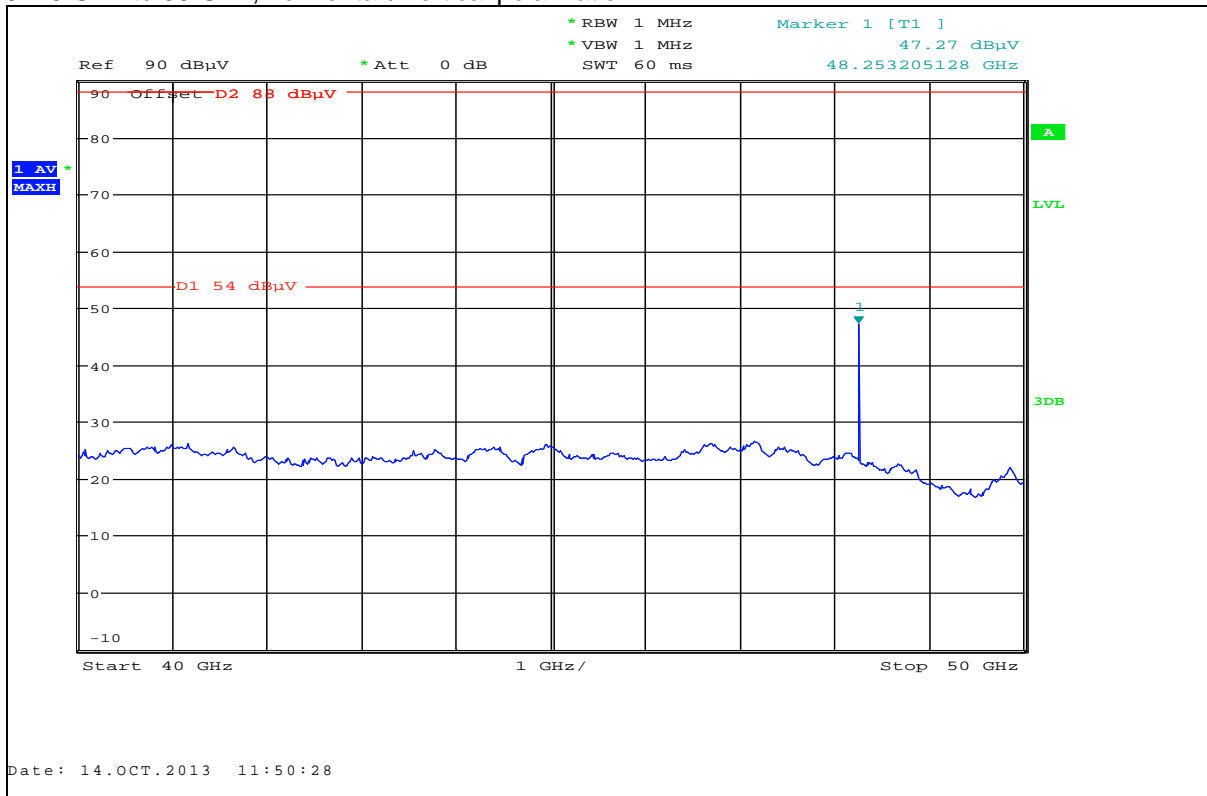

Plot 10: 50 GHz to 75 GHz, horizontal / vertical polarization

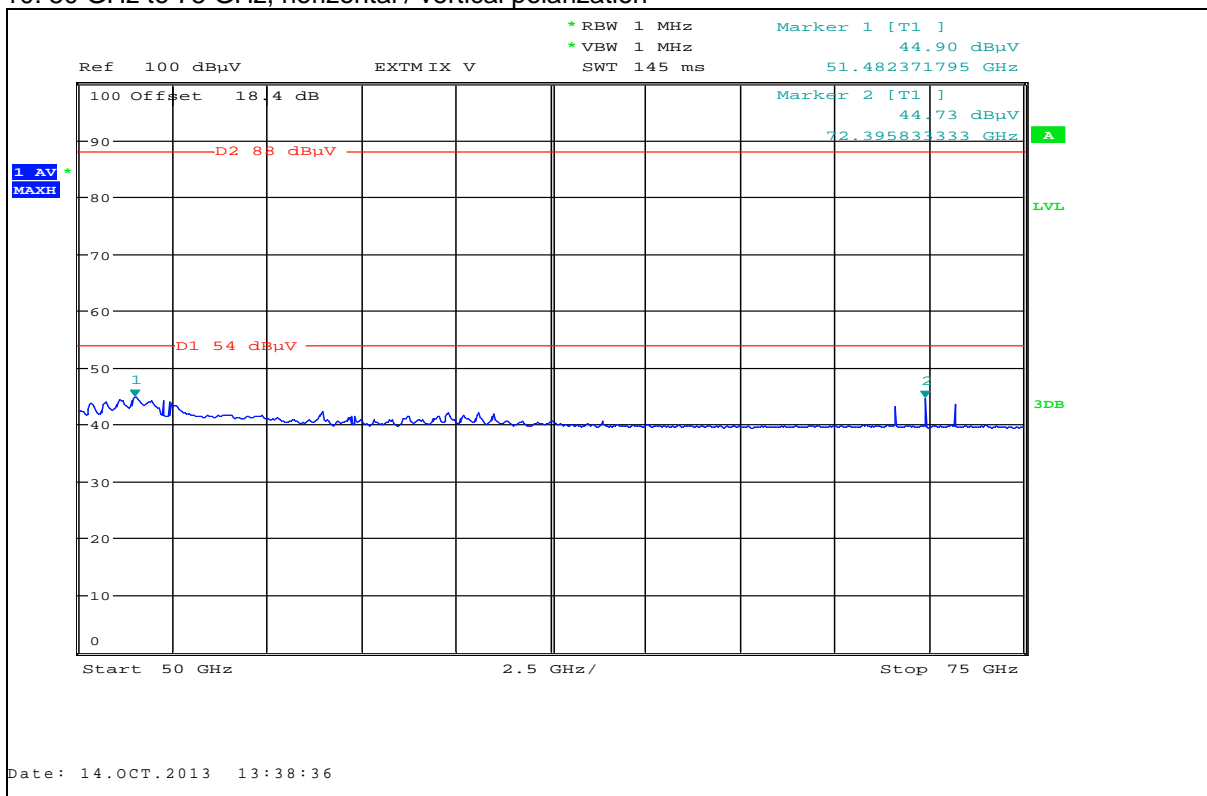

Plot 11: 3rd Harmonic, horizontal / vertical polarization

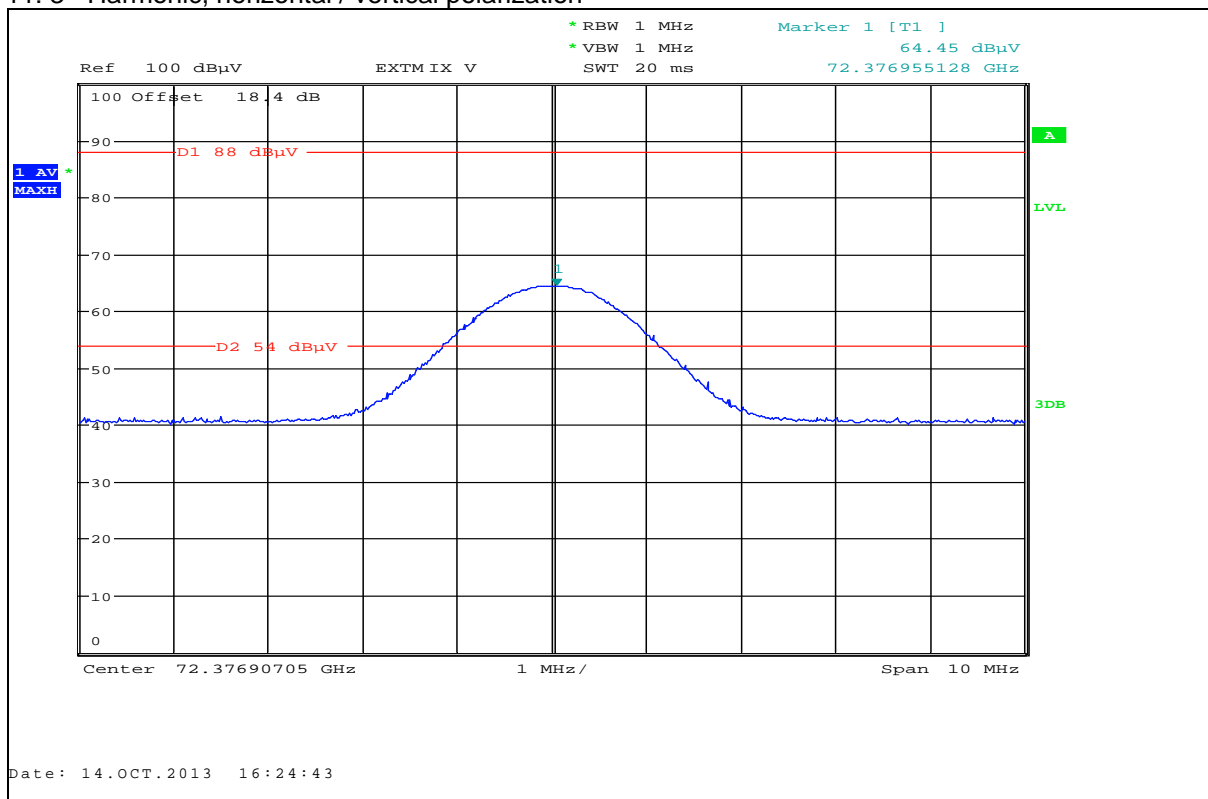

Plot 12: 75 GHz to 110 GHz, horizontal / vertical polarization

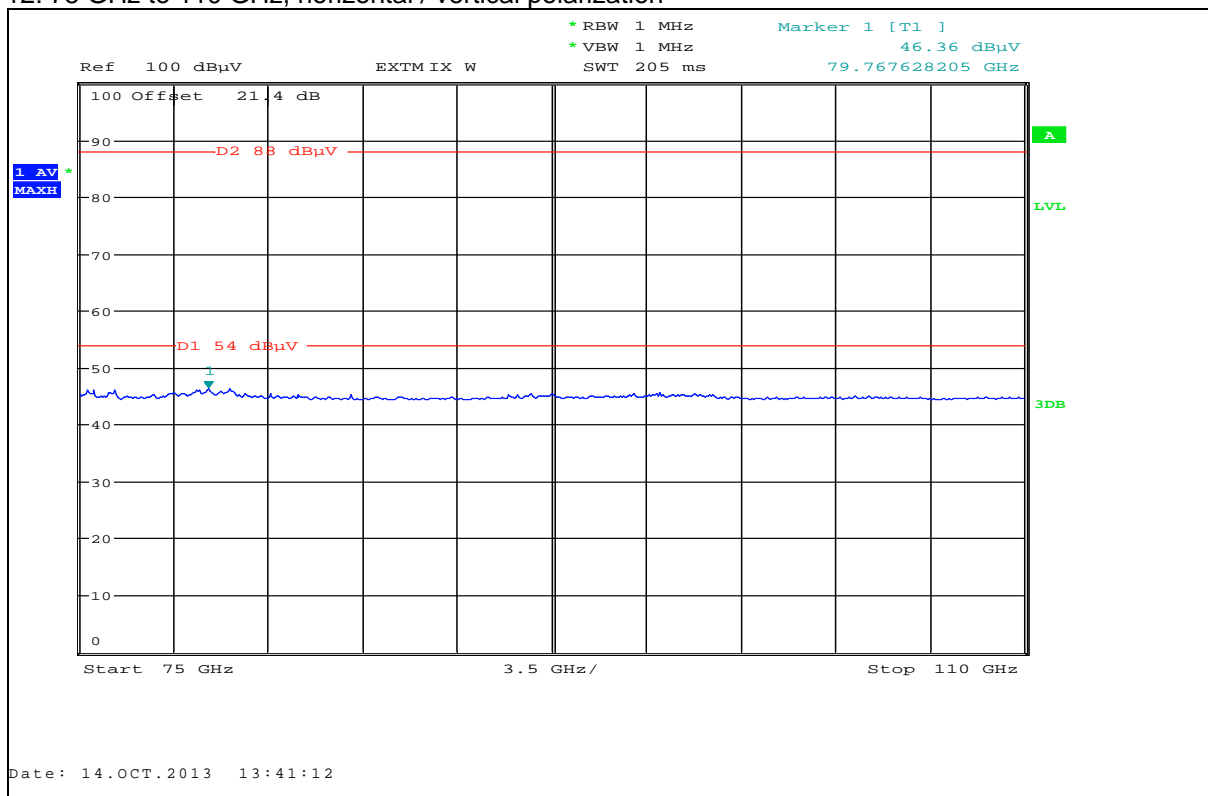

Plot 13: 4th Harmonic, horizontal / vertical polarization

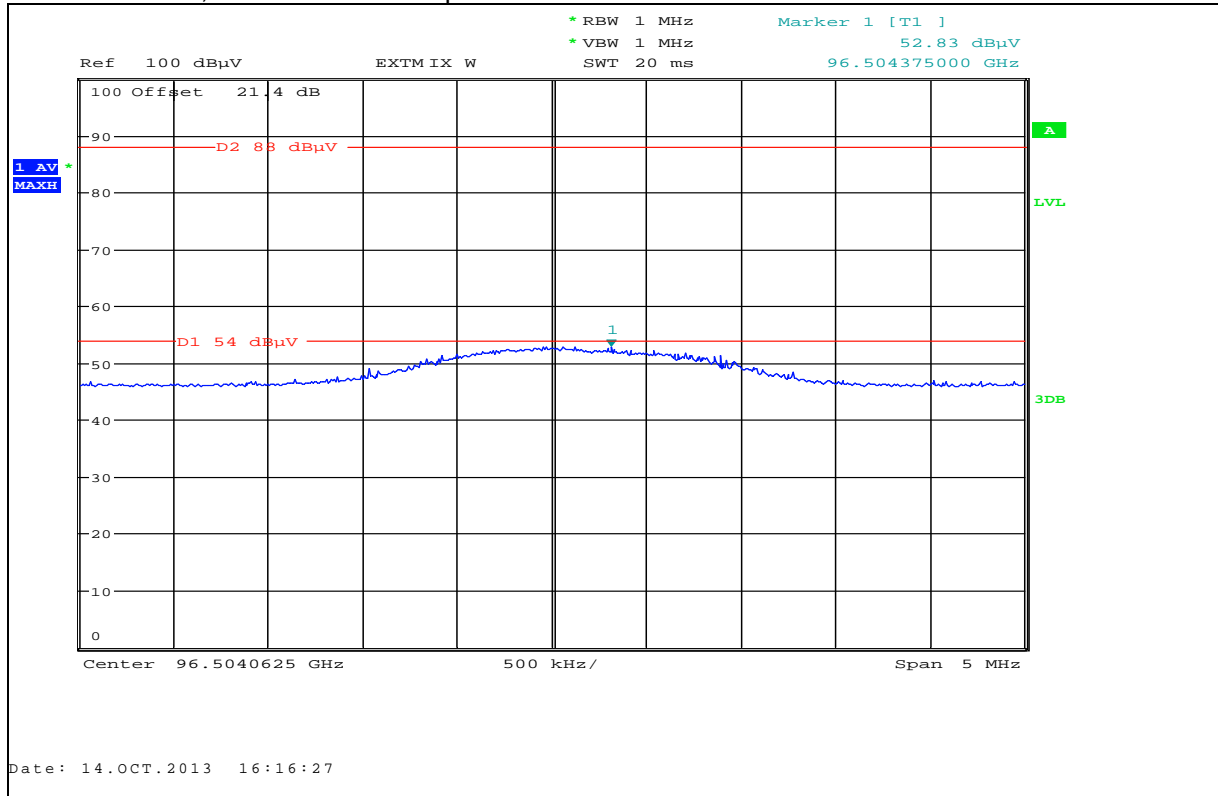

9.4 Conducted spurious emissions < 30 MHz

Description:

Measurement of the conducted spurious emissions in transmit mode below 30 MHz. Both power lines, phase and neutral line, are measured. Found peaks are re-measured with average and quasi peak detection to show compliance to the limits.

Measurement:

Measurement parameter	
Detector:	Peak - Quasi Peak / Average
Sweep time:	Auto
Video bandwidth:	F < 150 kHz: 200 Hz F > 150 kHz: 9 kHz
Resolution bandwidth:	F < 150 kHz: 1 kHz F > 150 kHz: 100 kHz
Span:	9 kHz to 30 MHz
Trace-Mode:	Max Hold

Limits:

FCC		IC	
CFR Part 15.207(a)		ICES-003, Issue 4	
Conducted Spurious Emissions < 30 MHz			
Frequency (MHz)	Quasi-Peak (dB μ V/m)	Average (dB μ V/m)	
0.15 – 0.5	66 to 56*	56 to 46*	
0.5 – 5	56	46	
5 – 30.0	60	50	

*Decreases with the logarithm of the frequency

Result: The measurement is passed.

Plot 14: Phase line

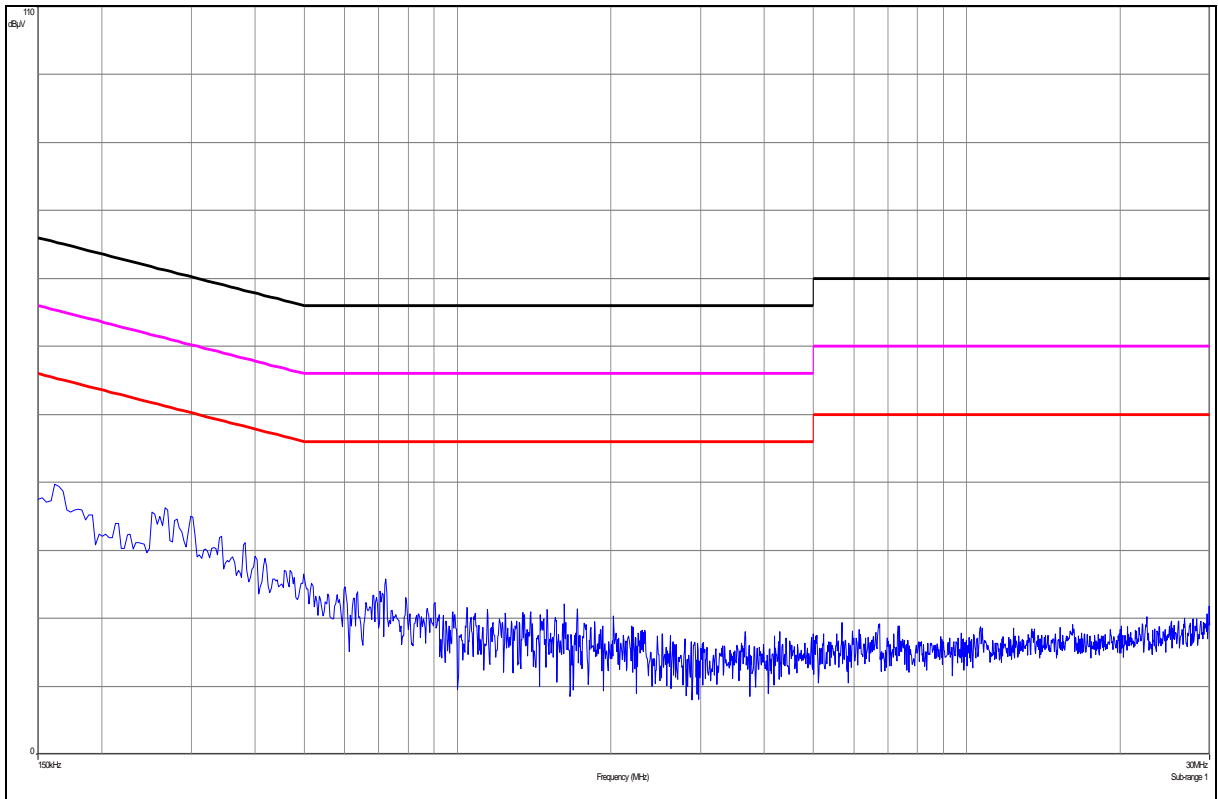

Plot 15: Neutral line

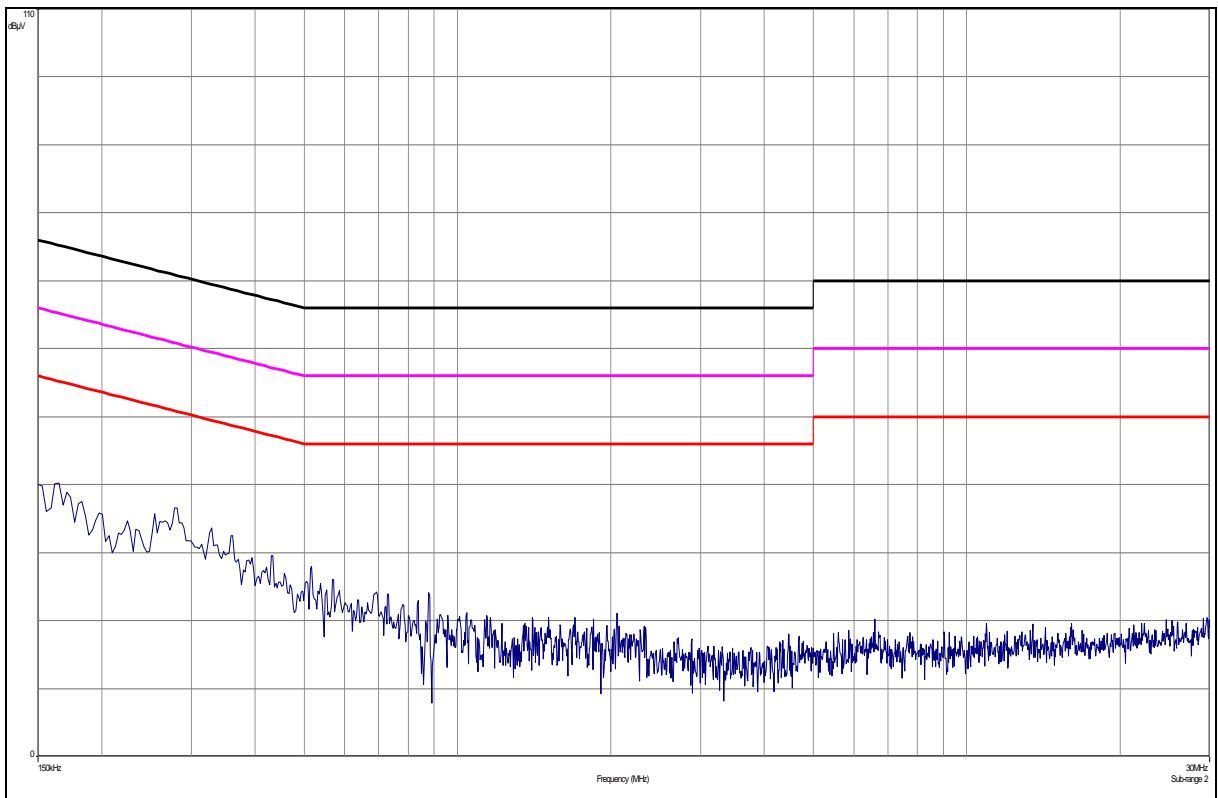

10 Test equipment and ancillaries used for tests

Typically, the calibrations of the test apparatus are commissioned to and performed by an accredited calibration laboratory. The calibration intervals are determined in accordance with the DIN EN ISO/IEC 17025. In addition to the external calibrations, the laboratory executes comparison measurements with other calibrated test systems or effective verifications. Weekly chamber inspections and range calibrations are performed. Where possible, rf-generating and signalling equipment as well as measuring receivers and analyzers are connected to an external high-precision 10 MHz reference (GPS-based or rubidium frequency standard).

In order to simplify the identification of the equipment used at some special tests, some items of test equipment and ancillaries can be provided with an identifier or number in the equipment list below (Labor/Item).

No.	Lab / Item	Equipment	Type	Manufact.	Serial No.	INV. No Cetecom	Kind of Calibration	Last Calibration	Next Calibration
1	45	Switch-Unit	3488A	HP Meßtechnik	2719A14505	300000368	g		
2	50	DC power supply, 60Vdc, 50A, 1200 W	6032A	HP Meßtechnik	2920A04466	300000580	ne		
3	n. a.	software	SPS_PHE 1.4f	Spitzberger & Spieß	B5981; 5D1081;B5979	300000210	ne		
4	n. a.	EMI Test Receiver	ESCI 3	R&S	100083	300003312	k	09.01.2013	09.01.2014
5	n. a.	Analyzer-Reference-System (Harmonics and Flicker)	ARS 16/1	SPS	A3509 07/0 0205	300003314	Ve	14.07.2011	14.01.2014
6	n. a.	Amplifier	JS42-00502650-28-5A	MITEQ	1084532	300003379	ev		
7	n. a.	Antenna Tower	Model 2175	ETS- LINDGREN	64762	300003745	izw		
8	n. a.	Positioning Controller	Model 2090	ETS- LINDGREN	64672	300003746	izw		
9	n. a.	Turntable Interface-Box	Model 105637	ETS- LINDGREN	44583	300003747	izw		
10	n. a.	TRILOG Broadband Test-Antenna 30 MHz - 3 GHz	VULB9163	Schwarzbeck	295	300003787	k	12.04.2012	12.04.2014
11	n. a.	Spectrum-Analyzer	FSU26	R&S	200809	300003874	k	16.01.2013	16.01.2014
12	n. a.	Anechoic chamber	FAC 3/5m	MWB / TDK	87400/02	300000996	ev		
13	9	Artificial Mains 9 kHz to 30 MHz	ESH3-Z5	R&S	828576/020	300001210	Ve	06.01.2012	06.01.2014
14	90	Active Loop Antenna 10 kHz to 30 MHz	6502	Kontron Psychotech	8905-2342	300000256	k	13.06.2013	13.06.2015
15	n. a.	MXE EMI Receiver 20 Hz bis 26,5 GHz	N9038A	Agilent Technologies	MY51210197	300004405	k	21.02.2013	21.02.2014
16	CR 79	Std. Gain Horn Antenna 26.5-40.0 GHz	V637	Narda	7911	300001751	ne		
17	11b	Microwave System Amplifier, 0.5-26.5 GHz	83017A	HP Meßtechnik	00419	300002268	ev		
18	A022	Std. Gain Horn Antenna 26.4-40.1 GHz	2224-20	Flann	235	300001976	ne		
19	A023	Std. Gain Horn Antenna 39.3-59.7 GHz	2424-20	Flann	75	300001979	ne		
20	A026	Std. Gain Horn Antenna 12.4 to 18.0 GHz	639	Narda	8402	300000787	k	22.07.2013	22.07.2015
21	A029	Std. Gain Horn Antenna 18.0 to 26.5 GHz	638	Narda		300002442	k	19.07.2013	19.07.2015

22	5	DC Power Supply, 60V, 10A	6038A	HP Meßtechnik	2848A07027	300001174	Ve	05.01.2012	05.01.2015
23	n. a.	Spectrum Analyzer 20 Hz - 50 GHz	FSU50	R&S	200012	300003443	Ve	09.10.2012	09.10.2014
24	n. a.	Harmonic mixer 50 - 75 GHz for spectrum analyzers	FS-Z75	R&S	100099	300003949	k	27.09.2012	27.03.2014
25	n. a.	Spectrum Analyzer Mixer 2-Port, 75-110 GHz	SAM-110-7	Radiometer Physics GmbH	002	300004155	k	11.09.2012	11.03.2014
26	n. a.	Broadband Low Noise Amplifier 18-50 GHz	CBL18503070-XX	CERNEX	19338	300004273	ne		

Agenda: Kind of Calibration

k	calibration / calibrated		EK	limited calibration
ne	not required (k, ev, izw, zw not required)		zw	cyclical maintenance (external cyclical maintenance)
ev	periodic self verification		izw	internal cyclical maintenance
Ve	long-term stability recognized		g	blocked for accredited testing
vkl!	Attention: extended calibration interval			
NK!	Attention: not calibrated		*)	next calibration ordered / currently in progress

11 Observations

No observations exceeding those reported with the single test cases have been made.

Annex A Photographs of the test setup

Photo 1:



Photo 2:

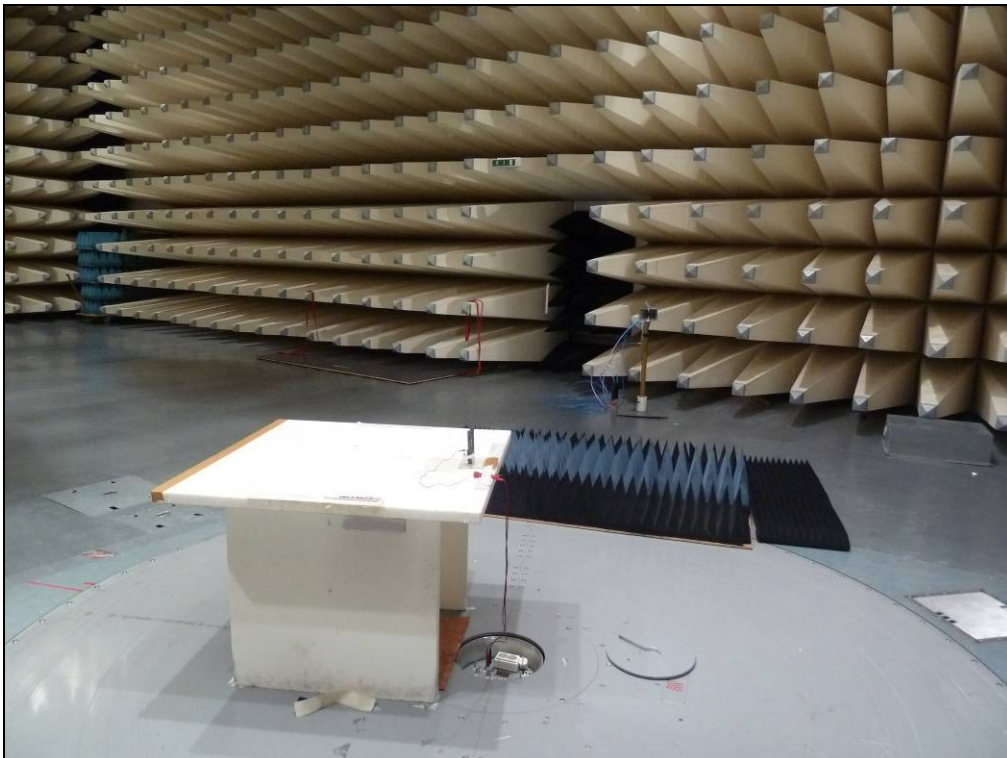
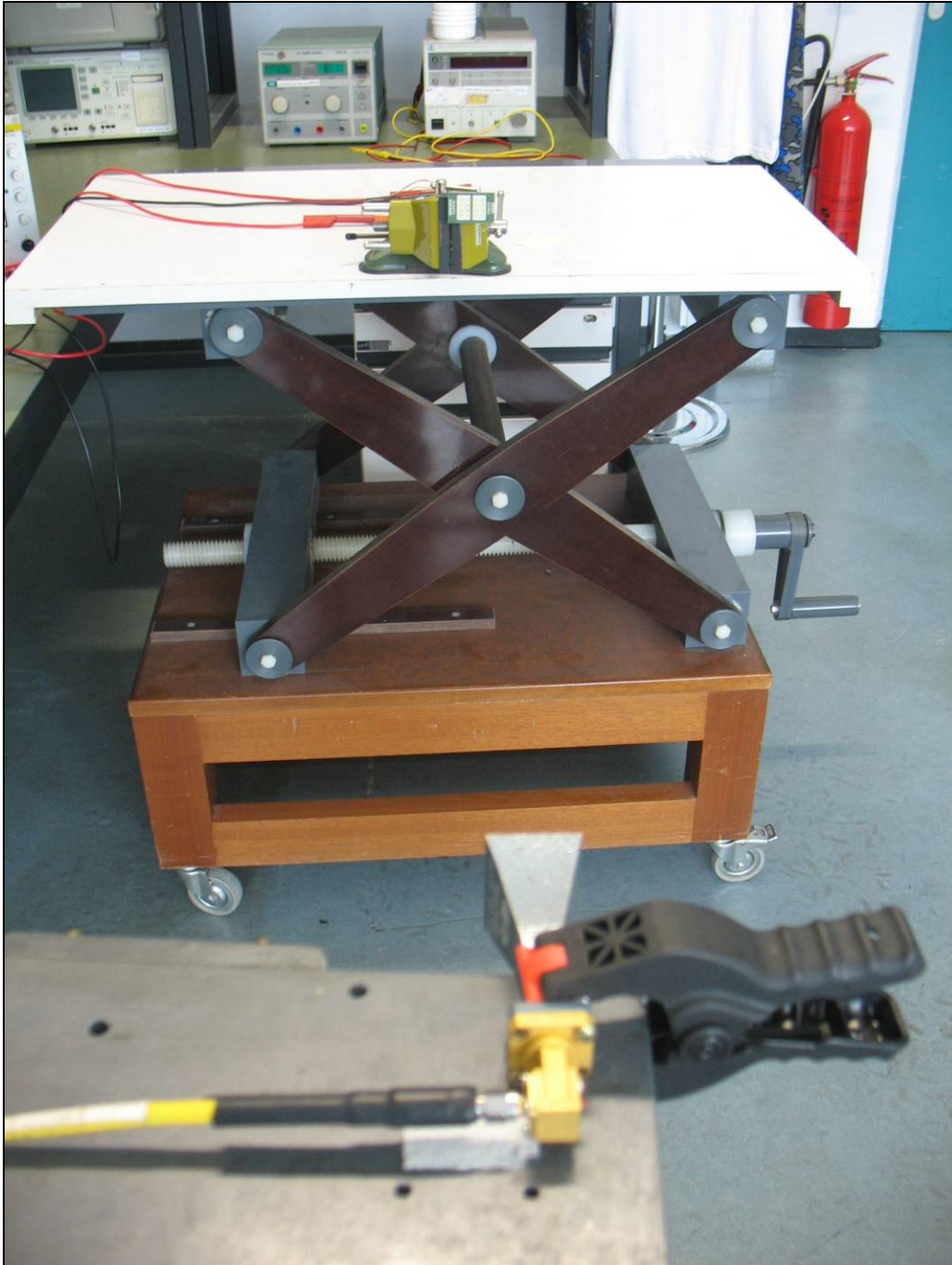

Photo 3:



Annex B Photographs of the EUT

Photo 4:



Photo 5:

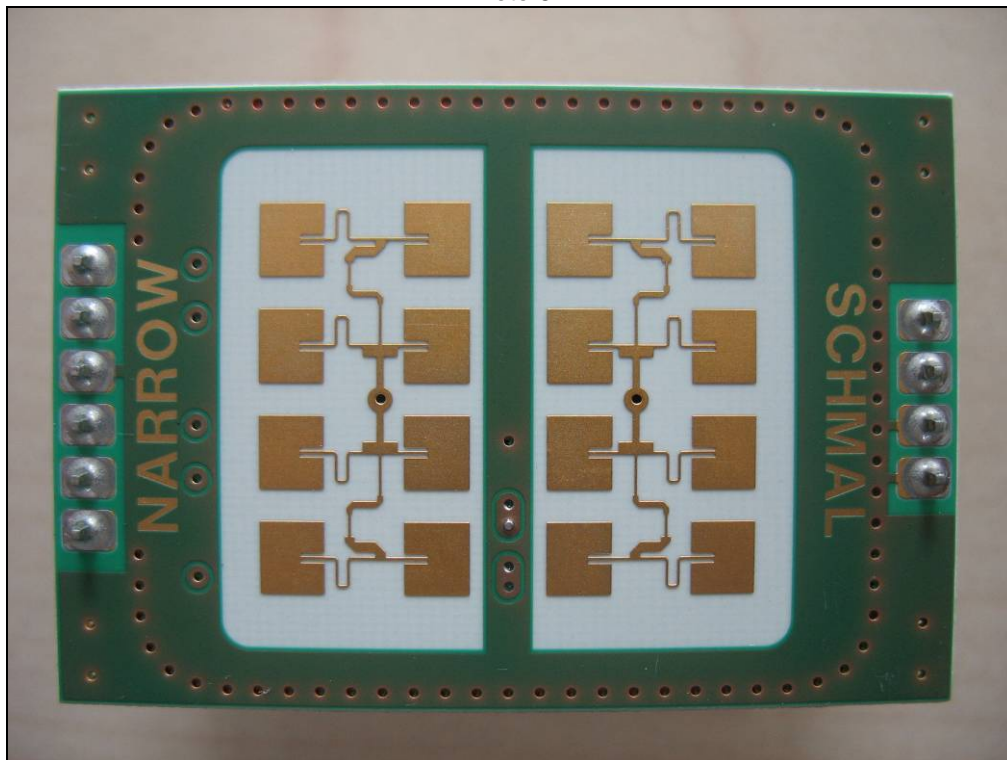
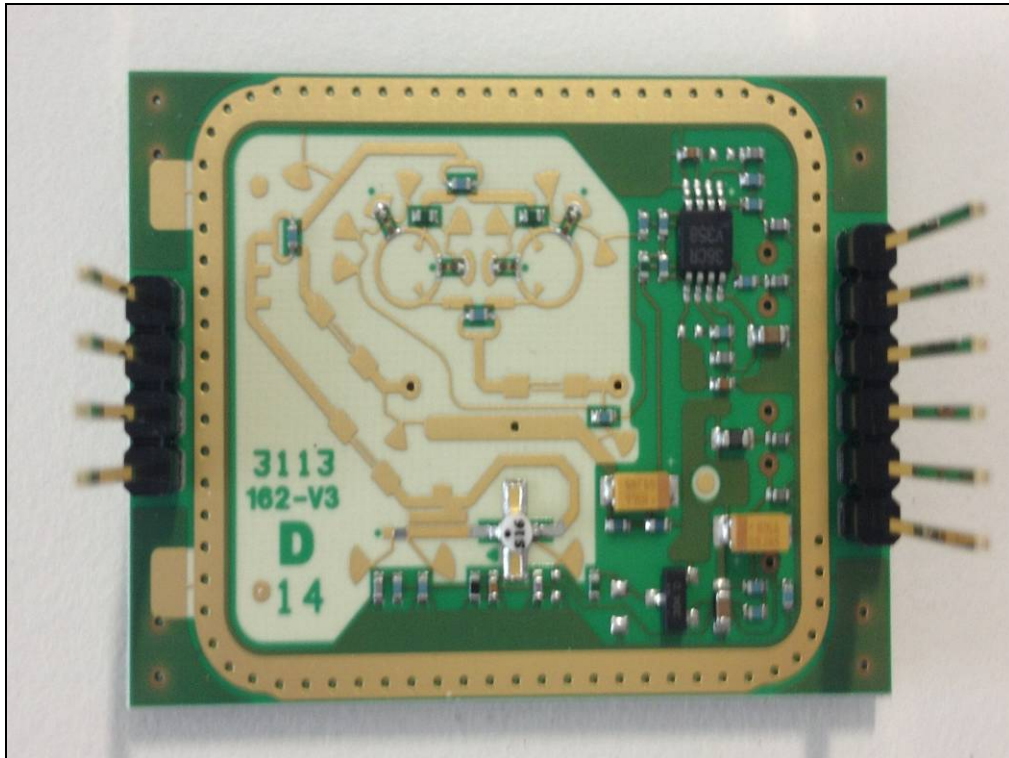

Photo 6:



Annex C Document history

Version	Applied changes	Date of release
1.0	Initial release	2013-12-17

Annex D Further information**Glossary**

AVG	-	Average
DUT	-	Device under test
EMC	-	Electromagnetic Compatibility
EN	-	European Standard
EUT	-	Equipment under test
ETSI	-	European Telecommunications Standard Institute
FCC	-	Federal Communication Commission
FCC ID	-	Company Identifier at FCC
HW	-	Hardware
IC	-	Industry Canada
Inv. No.	-	Inventory number
N/A	-	Not applicable
PP	-	Positive peak
QP	-	Quasi peak
S/N	-	Serial number
SW	-	Software

Annex E Accreditation Certificate

Front side of certificate



Deutsche Akkreditierungsstelle GmbH

Befehlense gemäß § 8 Absatz 1 AkkStelleG i.V.m. § 1 Absatz 1 AkkStelleGBV
 Unterzeichnerin der Multilateralen Abkommen
 von EA, ILAC und IAF zur gegenseitigen Anerkennung

Akkreditierung



Die Deutsche Akkreditierungsstelle GmbH bestätigt hiermit, dass das Prüflaboratorium

CETECOM ICT Services GmbH
 Untertürkheimer Straße 6-10, 66117 Saarbrücken

die Kompetenz nach DIN EN ISO/IEC 17025:2005 besitzt, Prüfungen in folgenden Bereichen durchzuführen:

- Drahtgebundene Kommunikation einschließlich xDSL
- VoIP und DECT
- Akustik
- Funk einschließlich WLAN
- Short Range Devices (SRD)
- RFID
- WiMax und Richtfunk
- Mobilfunk (GSM / DCS, Over the Air (OTA) Performance)
- Elektromagnetische Verträglichkeit (EMV) einschließlich Automotive
- Produktsicherheit
- SAR und Hearing Aid Compatibility (HAC)
- Umweltsimulation
- Smart Card Terminals
- Bluetooth
- Wi-Fi- Services

Die Akkreditierungskunde gilt nur in Verbindung mit dem Bescheid vom 18.01.2013 mit der Akkreditierungsnummer D-PL-12076-01 und ist gültig 17.01.2018. Sie besteht aus diesem Deckblatt, der Rückseite des Deckblatts und der folgenden Anlage mit insgesamt 80 Seiten.

Registrierungsnummer der Urkunde: D-PL-12076-01-01

Frankfurt am Main, 18.01.2013
 Seite 11/100 auf der Rückseite

Im Auftrag
 Dr. Ingrid Pöhl, Leiterin
 Abteilung I 10

Back side of certificate

Deutsche Akkreditierungsstelle GmbH

Standort Berlin
 Spittelmarkt 10
 10117 Berlin

Standort Frankfurt am Main
 Giärtenstraße 6
 60594 Frankfurt am Main

Standort Braunschweig
 Rundenallee 100
 38116 Braunschweig

Die auszugsweise Veröffentlichung der Akkreditierungskunde bedarf der vorherigen schriftlichen Zustimmung der Deutsche Akkreditierungsstelle GmbH (DAkkS). Ausgenommen davon ist die separate Weiterverbreitung des Deckblatts durch die umseitig genannte Konformitätsbewertungsstelle in unveränderter Form.

Es darf nicht der Anschein erweckt werden, dass sich die Akkreditierung auch auf Bereiche erstreckt, die über den durch die DAkkS bestätigten Akkreditierungsbereich hinausgehen.

Die Akkreditierung erfolgte gemäß des Gesetzes über die Akkreditierungsstelle (AkkStelleG) vom 31. Juli 2009 (BGBl. I S. 2625) sowie der Verordnung (EG) Nr. 765/2008 des Europäischen Parlaments und des Rates vom 9. Juli 2008 über die Vorschriften für die Akkreditierung und Marktüberwachung im Zusammenhang mit der Vermarktung von Produkten (Abt. L 218 vom 9. Juli 2008, S. 30). Die DAkkS ist Unterzeichnerin der Multilateralen Abkommen zur gegenseitigen Anerkennung der European co-operation for Accreditation (EA), des International Accreditation Forum (IAF) und der International Laboratory Accreditation Cooperation (ILAC). Die Unterzeichner dieser Abkommen erkennen ihre Akkreditierungen gegenseitig an.

Der aktuelle Stand der Mitgliedschaft kann folgenden Webseiten entnommen werden:

EA: www.european-accreditation.org
 ILAC: www.ilac.org
 IAF: www.iaf.nu

Note:

The current certificate including annex is published on our website (see link below) or may be received from CETECOM ICT Services on request.

<http://www.cetecom.com/eu/de/cetecom-group/europa/deutschland-saarbruecken/akkreditierungen.html>