

LM400

FREQUENCY-AGILE UHF BELT-PACK TRANSMITTER

OPERATING INSTRUCTIONS and trouble-shooting guide

LECTROSONICS, INC.

Rio Rancho, NM
www.lectrosonics.com

TABLE OF CONTENTS

INTRODUCTION	3
GENERAL TECHNICAL DESCRIPTION	4
CONTROLS AND FUNCTIONS	6
BATTERY INSTALLATION	8
OPERATING INSTRUCTIONS	8
OPERATING NOTES	9
ADJUSTING THE TRANSMITTER FREQUENCY	9
TROUBLESHOOTING	10
SPECIFICATIONS AND FEATURES	11
SERVICE AND REPAIR	12
RETURNING UNITS FOR REPAIR	12
WARRANTY	Back cover

The LM400 transmitter is FCC type accepted under Part 74: 536-608 MHz and 614-806 MHz

INTRODUCTION

Thank you for selecting the Lectrosonics LM400 frequency agile, belt-pack transmitter. The LM400 combines over 80 years of engineering experience with the very latest components, in a design that addresses the most demanding professional applications.

The design of the LM400 was the direct result of numerous conversations with users, staging and touring companies and dealers across the US. The specific concerns and needs brought up in these conversations led directly to the development of the operational features offered on the LM400. Two hundred fifty six frequencies are user selectable in 100kHz steps to alleviate interference problems in traveling venues, and the low frequency roll-off is user adjustable to adapt to varying acoustic environments and preferences.

The LM400 is a rugged, machined aluminum package with a removable, spring loaded belt clip. The input section provides 3.3 Volts of bias voltage to power electret mics. Level indicating LEDs are provided on the control panel to make level settings quick and accurate, without having to view the receiver. The battery compartment accepts any 9 Volt alkaline battery and makes a positive connection via self-adjusting contacts. The antenna is a permanently attached 1/4 wavelength flexible bronze cable.

Only the LM400 transmitter is covered in this manual. Companion receivers are covered in separate manuals. The LM400 will operate with any 400 Series Lectrosonics receiver in the same frequency group.

GENERAL TECHNICAL DESCRIPTION

GENERAL

The 400 system uses 75kHz wide deviation for an extremely high signal to noise ratio. The switching power supplies provide constant voltages to the transmitter circuits from the beginning (9.3 Volts) to the end (5.5 Volts) of battery life. The input amplifier uses an ultra low noise op amp for quiet operation. It is gain controlled with a wide range dual envelope input compressor which cleanly limits input signal peaks over 30dB above full modulation.

DIGITAL HYBRID TECHNOLOGY

All wireless links suffer from channel noise to some degree, and all wireless microphone systems seek to minimize the impact of that noise on the desired signal. Conventional analog systems use companders for enhanced dynamic range, at the cost of subtle artifacts (known as "pumping" and "breathing"). Wholly digital systems defeat the noise by sending the audio information in digital form, at the cost of some combination of power, bandwidth and resistance to interference.

The Lectrosonics Digital Hybrid system overcomes channel noise in a dramatically new way, digitally encoding the audio in the transmitter and decoding it in the receiver, yet still sending the encoded information via an analog FM wireless link. This proprietary algorithm is not a digital implementation of an analog compandor but a technique which can be accomplished only in the digital domain, even though the inputs and outputs are analog signals. (As of this writing, the patent is still pending, so we cannot reveal detailed information about the algorithm at this time.)

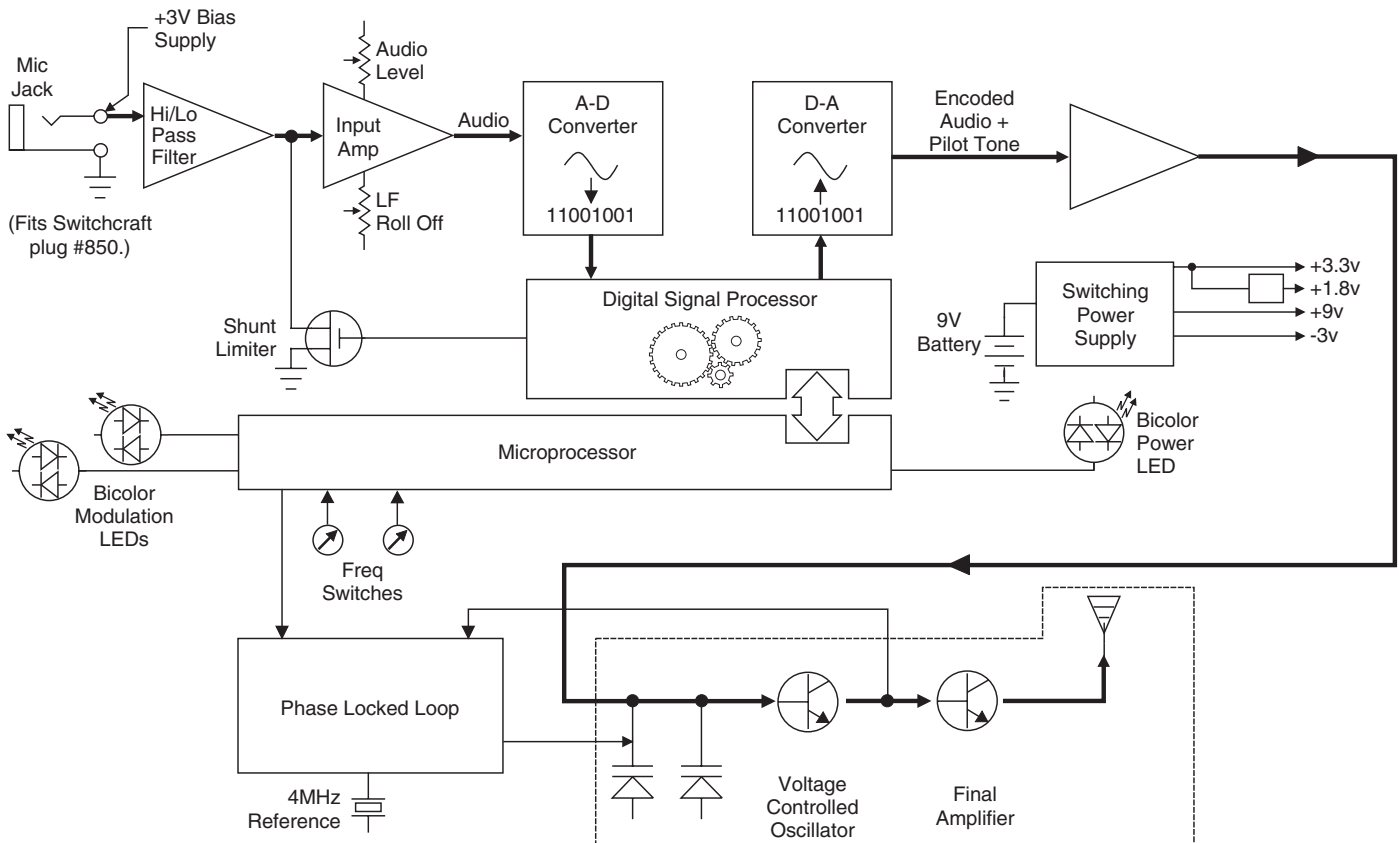

LM400 Block Diagram

Channel noise still has an impact on received signal quality and will eventually overwhelm the receiver. The Digital Hybrid simply encodes the signal to use a noisy channel as efficiently and robustly as possible, yielding audio performance that rivals that of wholly digital systems, without the power and bandwidth problems inherent in digital transmission. As always, these advantages come at a cost. The Digital Hybrid system requires fairly intensive digital processing in both the transmitter and the receiver. These processors cost money, take up space and consume power. The Digital Hybrid system also requires that the underlying RF link be of excellent quality, with better frequency response and distortion characteristics than that required by conventional systems.

Because it uses an analog FM link, the Digital Hybrid enjoys all the benefits of conventional FM wireless systems, such as excellent range, efficient use of RF spectrum, and long battery life. However, unlike conventional FM systems, the Digital Hybrid has done away with the analog compandor and its artifacts.

NO PRE-EMPHASIS/DE-EMPHASIS

The signal to noise ratio of the 400 system is high enough to preclude the need for conventional pre-emphasis (HF boost) in the transmitter and de-emphasis (HF roll off) in the receiver. Pre-emphasis and de-emphasis in an FM radio system usually provides about a 10dB improvement in the signal to noise ratio of the system, but the high frequency boost in the transmitter must be removed in a purely complementary manner or else the frequency response of the original audio signal will be altered.

Pre-emphasis can also cause distortion in the receiver. As this signal is passed through the IF filters in the receiver, distortion can be produced, most noticeably at full modulation. De-emphasis cannot be applied until the signal is converted into audio, so there is no way around this problem short of eliminating pre-emphasis altogether. Neither of these problems occur in the 400 system

PILOT TONE SQUELCH

The 400 system utilizes one of 256 different ultrasonic tones between 25 and 32 kHz, that modulate the carrier to operate the receiver squelch. The pilot tone frequency is chosen according to which of the 256 channels has been selected by the frequency switch setting. The basic benefit of the pilot tone squelch system is that the receiver will remain muted until it receives the pilot tone from the matching transmitter, even if a strong RF signal is present on the carrier frequency of the system. The LM400 extends this concept even further by insuring that all transmitters in a system have different pilot tone frequencies so that even spurious RF from the wrong transmitters can't open the receiver squelch.

WIDE-BAND DEVIATION

$\pm 75\text{kHz}$ deviation improves the capture ratio, signal to noise ratio and AM rejection of a wireless system dramatically, compared to the more commonly used $\pm 15\text{kHz}$ deviation.

LONG BATTERY LIFE

Switching power supplies throughout the design allow over 6 hours of operation using a single 9 Volt alkaline battery. (A 9V lithium battery will provide over 20 hours of operation.) The battery contacts are spring loaded to prevent "rattle" as the unit is handled.

FREQUENCY AGILITY

The transmitter section uses a synthesized, frequency selectable main oscillator. The frequency is extremely stable over a wide temperature range and over time.

Two rotary switches, located on the side panel of the unit, provide 256 frequencies in 100kHz steps over a 25.5MHz range. This alleviates carrier interference problems in mobile or traveling applications.

ANTENNA

The antenna on the LM400 consists of a permanently attached flexible 1/4 wavelength bronze cable.

CONTROLS AND FUNCTIONS

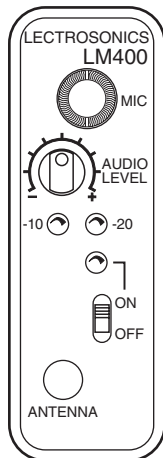

MIC

The Microplug (2.5 mm) input on the transmitter accommodates 2 wire positive bias lavalieres. This jack will mate with a Switchcraft 850 plug.

ON/OFF SWITCH

Turns the battery power on and off. Even when the switch is turned off or on abruptly, the pilot tone muting system prevents “thumps” or transients from occurring.

“ON” LAMP

Glowes green when the battery is good and the ON/OFF switch is ON. The lamp will glow yellow/orange as the battery voltage drops and finally glows red when there is about 30 minutes of operation left with the recommended alkaline battery. The lamp will flash red when there are only a few minutes of life left. A NiMh battery will give little or no warning when it is depleted. If you wish to use NiMh batteries in the LM400, we recommend trying fully charged batteries in the unit, noting the length of time that the batteries will run the unit and in the future use somewhat less than that time to determine when the battery needs to be replaced. A weak battery will sometimes light the POWER LED to the “good” green indication immediately after being put in the unit, but will soon discharge to the point where the LED will go red or shut down, just like a flashlight with “dead” batteries. If the lamp fails to light, the battery should be replaced.

FREQUENCY ADJUST

These two rotary switches adjust the center frequency of the carrier. The 1.6M is a coarse adjustment and the 100K is the fine adjustment.

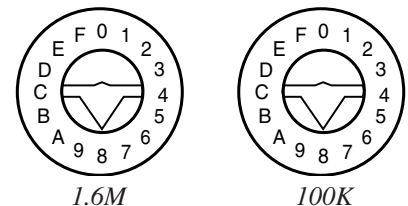

MODULATION LEDS

Indicate the proper setting of the MIC LEVEL control. There are two bicolor modulation LEDs that can light either red or green.

- “-20dB level” One modulation LED glows green and the transmitter is 20 dB below full modulation.
- “-10 dB level” Both modulation LEDs glow green and the transmitter is close to full modulation.
- “+0 dB level” The -20 LED glows red and the -10 LED glows green. The transmitter is in slight limiting and is fully modulated. This is probably desirable. See the discussion below under **Input Limiter**.
- “+10 dB level” Both LEDs are red. The transmitter is in limiting and you may want to reduce the transmitter audio gain. See the discussion below under **Input Limiter**.

INPUT LIMITER

The 400 series transmitters employ a digitally-controlled analog audio limiter just before the analog-to-digital converter. The limiter has a range of more than 30dB for excellent overload protection. A dual release envelope makes the limiter acoustically transparent while maintaining low distortion. It can be thought of as two limiters in series, connected as a fast attack and release limiter followed by a slow attack and release limiter. The limiter recovers quickly from brief transients, so that its action is hidden from the listener, but recovers slowly from sustained high levels, to both keep audio distortion low and preserve short term dynamic changes.

The audio level LEDs indicate limiter activity. The first red LED indicates that the limiter is active and that the transmitter is fully modulated (audio level is between +0 and +10 dB). The second red LED indicates that the level is 10dB or more into limiting. Occasional forays into the red are desirable for most applications, since the distortion introduced by the limiter is so minimal, and full modulation is thus assured. We strongly recommend setting the gain of the transmitter high enough so that the first red LED occasionally lights.

Generally speaking, some limiting is desirable in normal operation to improve the signal to noise ratio of the system. The limiting action is not audible and does not create distortion. A highly trained ear would hear only the compression of the peaks in the audio signal, which is desirable with most recorders and many sound reinforcement systems.

AUDIO LEVEL

Used to adjust the audio input level for the proper modulation.

ANTENNA

The flexible bronze cable antenna supplied with the transmitter is cut to 1/4 wavelength of the center of the frequency block (the frequency range) of the transmitter.

ADJUSTABLE LOW FREQUENCY ROLL-OFF

A 12dB per octave low frequency roll-off is provided in the audio section, with the -3dB point at 70Hz. The actual roll-off frequency will vary somewhat according to the low frequency response of the mic capsule being used.

The low frequency roll-off control is used to remove subsonic (or very low frequency) audio, often produced by air conditioning systems, automobile traffic and other sources from the audio signal. Excessive low frequency content in the audio input can cause a variety of audio problems including driving the transmitter into limiting. In sound reinforcement systems, as one instance, excessive low frequency content can cause excessive power amplifier drain or even damage to loudspeaker systems.

THE BELT CLIP

The belt clip may be removed for special applications by pulling the ends out of the holes in the sides of the case.

BATTERY INSTALLATION

The transmitter is powered by a standard alkaline or lithium 9 Volt battery. It is important that you use **ONLY** an **ALKALINE** or **LITHIUM** battery for longest life. Standard zinc-carbon batteries marked “**heavy-duty**” or “**long-lasting**” are not adequate. Ni-cad rechargeable batteries will only provide 1.5 hours of operation, or less, and will run down quite abruptly. Alkaline batteries provide over 6 hours of operation at room temperature. Lithium batteries can be used to provide up to 20 hours and will work at lower temperatures. Care should be taken not to leave a fully discharged lithium battery in the transmitter, as swelling of the battery can make it difficult to remove from the compartment. The battery status circuitry is designed for the voltage drop over the life of alkaline batteries.

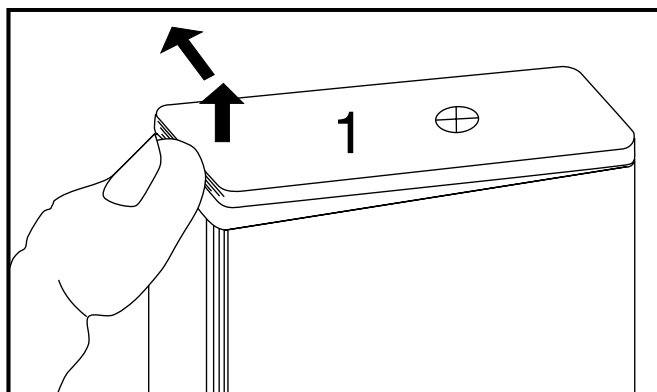

To open the battery compartment door, push the door up and away from the case with your thumb, then swing open.

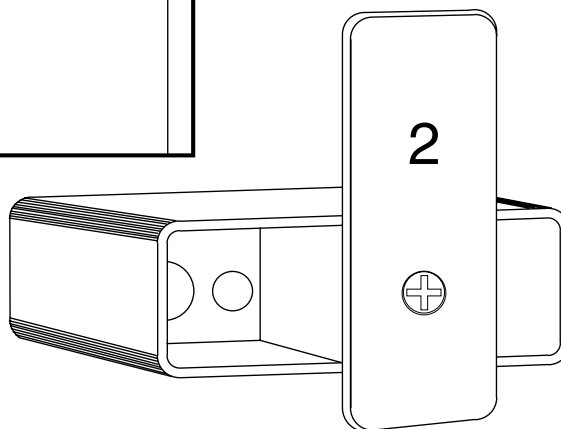

Swing the door open and take note of the polarity marked inside showing the location of the positive (+) and negative (-) terminals. You can see the large and small contact holes inside the battery compartment with the door open.

Insert the battery correctly and close the cover by rotating the door, reversing the opening procedure illustrated above. If the battery is inserted incorrectly, the door will not close. Do not force the door closed.

OPERATING INSTRUCTIONS

- 1) Install a fresh battery according to the instructions above.
- 2) Insert the microphone plug into the input jack. Turn the plug clockwise to lock it to the jack.
- 3) Mute the sound system.
- 4) Turn the transmitter power switch to the “ON” position.
- 5) Position the microphone in the location you will use in actual operation.
- 6) While speaking or singing at the same voice level that will actually be used, observe the MODULATION LEDs. Adjust the AUDIO LEVEL control knob until the LEDs begin to light. At too low a setting neither LED will light as you speak. Gradually, turn the gain up until the -20 dB LED lights green and then the -10 dB lights green. We strongly recommend setting the gain of the transmitter even higher so that the first red LED occasionally lights.
- 7) Once the gain has been adjusted, the audio system audio can be turned on to make level adjustments in the main audio system.

OPERATING NOTES

The AUDIO LEVEL control knob should not be used to control the volume of your sound system or recorder levels. This gain adjustment matches the transmitter gain with the user's voice level and microphone positioning.

If the audio level is too high — both red LEDs will light frequently or stay lit. This condition may reduce the dynamic range of the audio signal.

If the audio level is too low — neither LED will light, or only the -20 LED will light green. This condition may cause hiss and noise in the audio.

Different voices will usually require different settings of the AUDIO LEVEL control, so check this adjustment as each new person uses the system. If several different people will be using the transmitter and there is not time to make the adjustment for each individual, adjust it for the loudest voice.

ADJUSTING THE TRANSMITTER FREQUENCY

If you are experiencing interference from another signal on your frequency, you may want to change the operating frequency of your system. The left switch changes the operating frequency by 1.6 MHz per step and the right switch changes it 100 kHz per step. If you are experiencing interference, change the operating frequency to find a clear channel.

To gain access to these switches, slide the access door sideways with a fingernail.

With the 400 series receivers, the front panel LCD character display will indicate the correct transmitter switch settings. Use the scanning functions on the receiver to find a clear channel.

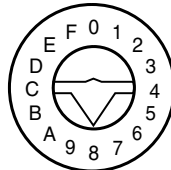

1.6M

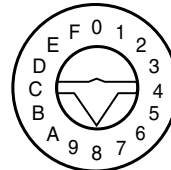

100K

TROUBLESHOOTING

Before going through the following chart, be sure that you have a good battery in the transmitter. It is important that you follow these steps in the sequence listed.

SYMPTOM	POSSIBLE CAUSE
TRANSMITTER BATTERY LED OFF	<ol style="list-style-type: none"> 1) Battery is inserted backwards. 2) Battery is dead.
NO TRANSMITTER MODULATION LEDs	<ol style="list-style-type: none"> 1) Gain control turned all the way down. 2) Battery is in backwards. Check power LED. 3) Mic capsule is damaged or malfunctioning. 4) Mic cable damaged or mis-wired.
RECEIVER RF LAMP OFF	<ol style="list-style-type: none"> 1) Transmitter not turned on. 2) Transmitter battery is dead. 3) Receiver antenna missing or improperly positioned. 4) Transmitter and receiver not on same frequency. Check switches/display on transmitter and receiver. 5) Operating range is too great.
NO SOUND (OR LOW SOUND LEVEL), RECEIVER INDICATES PROPER AUDIO MODULATION	<ol style="list-style-type: none"> 1) Receiver output level set too low. 2) Receiver output is disconnected; cable is defective or mis-wired. 3) Sound system or recorder input is turned down.
DISTORTED SOUND	<ol style="list-style-type: none"> 1) Transmitter gain (audio level) is far too high. Check mod level lamps on transmitter and receiver as it is being used. (refer to pages 8/9 for details on gain adjustment) 2) Receiver output may be mis-matched with the sound system or recorder input. Adjust output level on receiver to the correct level for the recorder, mixer or sound system. 3) Excessive wind noise or breath "pops." Reposition microphone and/or use a larger windscreen. 4) Transmitter is not set to same frequency as receiver. Check that frequency select switches on receiver and transmitter match.
HISS AND NOISE -- AUDIBLE DROPOUTS	<ol style="list-style-type: none"> 1) Transmitter gain (audio level) far too low. 2) Receiver antenna missing or obstructed. 3) Transmitter antenna missing. 4) Operating range too great.
EXCESSIVE FEEDBACK	<ol style="list-style-type: none"> 1) Transmitter gain (audio level) too high. Check gain adjustment and/or reduce receiver output level. 2) Transmitter too close to speaker system. 3) Mic is too far from user's mouth.

SPECIFICATIONS AND FEATURES

Operating frequencies:	537.600 to 607.900 MHz 614.100 to 793.500 MHz
Frequency selection:	256 frequencies in 100kHz steps
RF Power output:	60 mW (nominal)
Pilot tone:	25 to 32 kHz frequency; 5kHz deviation
Frequency stability:	± 0.002%
Deviation:	± 75 kHz (max)
Spurious radiation:	60 dB below carrier
Equivalent input noise:	-120 dBV, A-weighted
Input level:	Nominal 2 mV to 300 mV, before limiting. Greater than 1V maximum, with limiting.
Input impedance:	2k Ohm
Input compressor:	Dual envelope compressor, >30 dB range
Gain control range:	43 dB; semi-log rotary control
Modulation indicators:	Dual bicolor LEDs indicate modulation of -20, -10, 0, +10 dB referenced to full modulation.
Low frequency roll-off:	-12dB/octave; 70Hz
Audio frequency response (overall system):	70 Hz to 20 kHz (+/- 1dB) with the 70Hz low frequency roll-off filter. (The transmitter is deliberately rolled off at 70Hz to reduce the undesired effects of the lower frequencies.)
Controls:	2 position "OFF-ON" slide switch for noiseless turn on/turn off operation. Front panel knob adjusts audio gain. Rotary switches on side panel adjust transmitter frequency.
Audio Input Jack:	Switchcraft 2.5mm micro jack. Matches Switchcraft #851 locking plug.
Antenna:	Bronze, flexible wire.
Battery:	Precision compartment auto-adjusts to accept any known alkaline 9 Volt battery. (We've tried 243 different ones!)
Battery Life:	6 hours (alkaline); 20 hours (lithium)
Weight:	6.3 ozs. including battery
Dimensions:	3.1 x 2.4 x .75 inches

Emission Designator: 180KF3E

Specifications subject to change without notice.

The FCC requires that the following statement be included in this manual:

This device complies with FCC radiation exposure limits as set forth for an uncontrolled environment. This device should be installed and operated so that its antenna(s) are not co-located or operating in conjunction with any other antenna or transmitter.

SERVICE AND REPAIR

If your system malfunctions, you should attempt to correct or isolate the trouble before concluding that the equipment needs repair. Make sure you have followed the setup procedure and operating instructions. Check out the interconnecting cords and then go through the TROUBLESHOOTING section in the manual

We strongly recommend that you **do not** try to repair the equipment yourself and **do not** have the local repair shop attempt anything other than the simplest repair. If the repair is more complicated than a broken wire or loose connection, send the unit to the factory for repair and service. Don't attempt to adjust any controls inside the units. Once set at the factory, the various controls and trimmers do not drift with age or vibration and never require readjustment. **There are no adjustments inside that will make a malfunctioning unit start working.**

LECTROSONICS' service department is equipped and staffed to quickly repair your equipment. In warranty repairs are made at no charge in accordance with the terms of the warranty. Out of warranty repairs are charged at a modest flat rate plus parts and shipping. Since it takes almost as much time and effort to determine what is wrong as it does to make the repair, there is a charge for an exact quotation. We will be happy to quote approximate charges by phone for out of warranty repairs.

RETURNING UNITS FOR REPAIR

You will save yourself time and trouble if you will follow the steps below:

- A.** DO NOT return equipment to the factory for repair without first contacting us by letter or by phone. We need to know the nature of the problem, the model number and the serial number of the equipment. We also need a phone number where you can be reached 8 am to 4 pm (Mountain Standard Time).
- B.** After receiving your request, we will issue you a return authorization number (R.A.). This number will help speed your repair through our receiving and repair departments. The return authorization number must be clearly shown on the outside of the shipping container.
- C.** Pack the equipment carefully and ship to us, shipping costs prepaid. If necessary, we can provide you with the proper packing materials. UPS is usually the best way to ship the units. Heavy units should be "double-boxed" for safe transport.
- D.** We also strongly recommend that you insure the equipment, since we cannot be responsible for loss of or damage to equipment that you ship. Of course, we insure the equipment when we ship it back to you.

Mailing address:

Lectrosonics, Inc.
PO Box 15900
Rio Rancho, NM 87174
USA

Shipping address:

Lectrosonics, Inc.
581 Laser Rd.
Rio Rancho, NM 87124
USA

Telephones:

Regular: (505) 892-4501
Toll Free (800) 821-1121
FAX: (505) 892-6243

Web: <http://www.lectrosonics.com>

Email: sales@lectrosonics.com

This page intentionally blank.

LIMITED ONE YEAR WARRANTY

The equipment is warranted for one year from date of purchase against defects in materials or workmanship provided it was purchased from an authorized dealer. This warranty does not cover equipment which has been abused or damaged by careless handling or shipping. This warranty does not apply to used or demonstrator equipment.

Should any defect develop, Lectrosonics, Inc. will, at our option, repair or replace any defective parts without charge for either parts or labor. If Lectrosonics, Inc. cannot correct the defect in your equipment, it will be replaced at no charge with a similar new item. Lectrosonics, Inc. will pay for the cost of returning your equipment to you.

This warranty applies only to items returned to Lectrosonics, Inc. or an authorized dealer, shipping costs prepaid, within one year from the date of purchase.

This Limited Warranty is governed by the laws of the State of New Mexico. It states the entire liability of Lectrosonics Inc. and the entire remedy of the purchaser for any breach of warranty as outlined above. NEITHER LECTROSONICS, INC. NOR ANYONE INVOLVED IN THE PRODUCTION OR DELIVERY OF THE EQUIPMENT SHALL BE LIABLE FOR ANY INDIRECT, SPECIAL, PUNITIVE, CONSEQUENTIAL, OR INCIDENTAL DAMAGES ARISING OUT OF THE USE OR INABILITY TO USE THIS EQUIPMENT EVEN IF LECTROSONICS, INC. HAS BEEN ADVISED OF THE POSSIBILITY OF SUCH DAMAGES. IN NO EVENT SHALL THE LIABILITY OF LECTROSONICS, INC. EXCEED THE PURCHASE PRICE OF ANY DEFECTIVE EQUIPMENT.

This warranty gives you specific legal rights. You may have additional legal rights which vary from state to state.

LECTROSONICS, INC.

581 LASER ROAD
RIO RANCHO, NM 87124 USA
www.lectrosonics.com

February 17, 2003