

DPR

Plug-On Transmitter

With Digital Hybrid Wireless® Technology



Digital Hybrid Wireless®
US Patent 7,225,135



Fill in for your records:

Serial Number:

Purchase Date:



Table of Contents

General Technical Description	4
Features.....	6
Battery Installation	7
Attaching/Removing a Microphone	7
Operating Instructions	8
Transmitter Operating Instructions	8
Recorder Operating Instructions	8
Memory Card Preparation.....	9
DPR Menu.....	10
Setup Screen Details	12
Input Menu	12
Xmit Menu	14
SDCard Menu	14
TCode Menu	15
Key Menu.....	16
Setup Menu	16
About	17
LectroRM	18
Accessories	19
Specifications and Features.....	20
Firmware Update	21
Recovery Process	22
Service and Repair	23
Returning Units for Repair	23

For body worn operation, this transmitter model has been tested and meets the FCC RF exposure guidelines when used with the Lectrosonics accessories supplied or designated for this product. Use of other accessories may not ensure compliance with FCC RF exposure guidelines. Contact Lectrosonics if you have any questions or need more information about RF exposure using this product..

This device complies with FCC radiation exposure limits as set forth for an uncontrolled environment. This device should be installed and operated so that its antenna(s) are not co-located or operating in conjunction with any other antenna or transmitter.

This device complies with ISED Canada radiation exposure limits as set forth for an uncontrolled environment.

Cet appareil est conforme avec les normes d'Industrie Canada concernant les limites d'exposition aux radiations pour un environnement incontrôlé.

This radio transmitter [IC: 8024A-DPR] has been approved by Innovation, Science and Economic Development Canada to operate with the antenna types listed below, with the maximum permissible gain indicated. Antenna types not included in this list that have a gain greater than the maximum gain indicated for any type listed are strictly prohibited for use with this device.

Thank you for selecting a Lectrosonics DPR plug-On transmitter. The unique design provides several distinct features for professional applications:

- Outstanding UHF operating range
- Superb audio quality
- On board recording
- Corrosion-resistant housing

The Digital Hybrid Wireless® design (US Patent 7,225,135) combines 24-bit digital audio with analog FM resulting in a system that has the same operating range as analog systems, the same spectral efficiency as analog systems, the same long battery life as analog systems, plus the excellent audio fidelity typical of pure digital systems.

General Technical Description

The transmitter uses a standard 3-pin XLR input jack for use with any microphone with a mating XLR connector. An LCD, membrane switches and multi-color LEDs on the control panel make input gain adjustments and frequency selection quick and accurate, without having to view the receiver. The housing is machined from a solid aluminum block to provide a lightweight and rugged package. A special non-corrosive finish resists salt water exposure and perspiration in extreme environments.

The DPR transmitter uses ± 75 kHz wide deviation for an excellent signal to noise ratio and wide dynamic range. The DSP controlled input limiter features a wide range dual envelope design which cleanly limits input signal peaks over 30 dB above full modulation. Switching power supplies provide constant voltages to the trans-

mitter circuits from the beginning (3 Volts) to the end (1.7 Volts) of battery life, and an ultra low noise input amplifier for quiet operation.

Digital Hybrid Wireless® Technology

All wireless links suffer from channel noise to some degree, and all wireless microphone systems seek to minimize the impact of that noise on the desired signal. Conventional analog systems use companders for enhanced dynamic range, at the cost of subtle artifacts (known as “pumping” and “breathing”). Wholly digital systems defeat the noise by sending the audio information in digital form, at the cost of some combination of power, bandwidth and resistance to interference.

Lectrosonics Digital Hybrid Wireless® systems overcome channel noise in a dramatically new way, digitally encoding the audio in the transmitter and decoding it in the receiver, yet still sending the encoded information via an analog FM wireless link. This proprietary algorithm is not a digital implementation of an analog compandor but a technique that can be accomplished only in the digital domain, even though the inputs and outputs are analog.

Channel noise still impacts received signal quality and will eventually overwhelm a receiver. Digital Hybrid Wireless® simply encodes the signal to use a noisy channel as efficiently and robustly as possible, yielding audio performance that rivals that of wholly digital systems, without the power and bandwidth problems inherent in digital transmission.

Because it uses an analog FM link, Digital Hybrid Wireless® enjoys all the benefits of conventional FM wireless systems, such as excellent range, efficient use of RF spectrum, and resistance to interference. However, unlike conventional FM systems, it does away with the analog compandor and its artifacts.

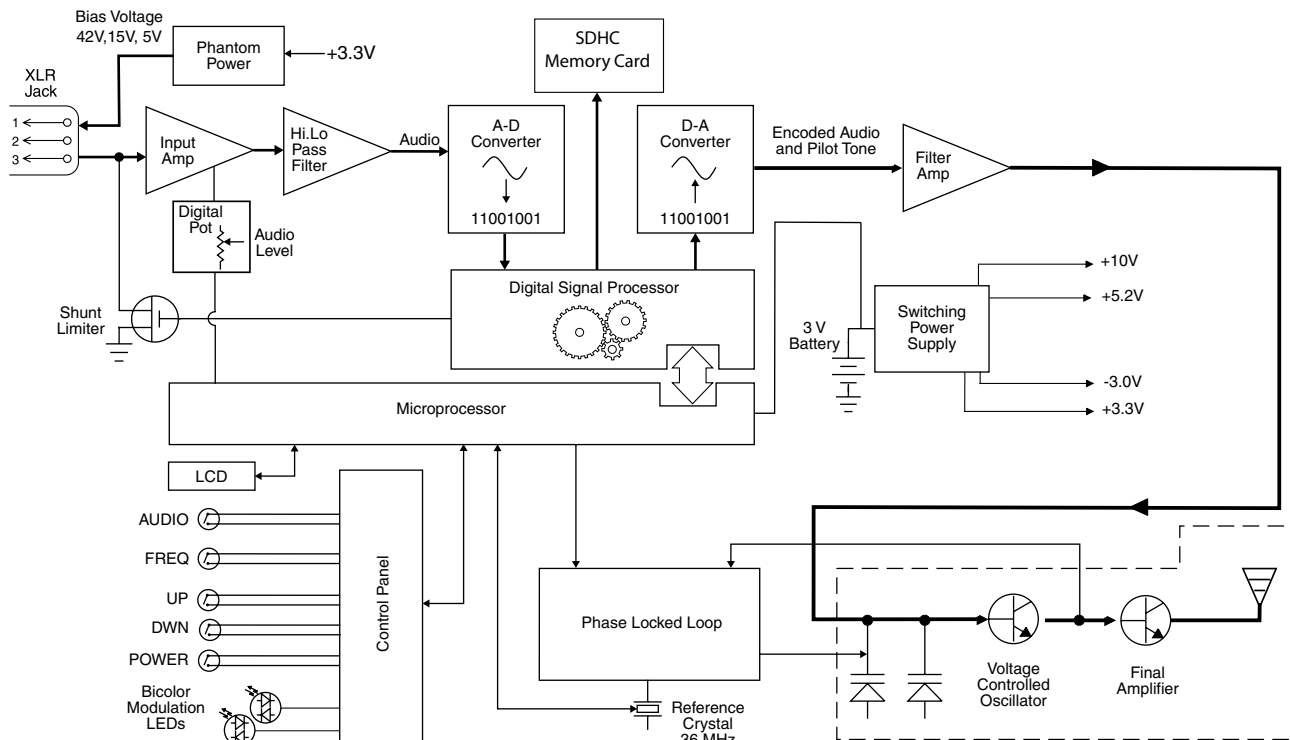

Outstanding Audio Performance

The audio performance of the overall hybrid system is depicted in the graph below. Distortion in the system is extremely low over the entire audio bandwidth.

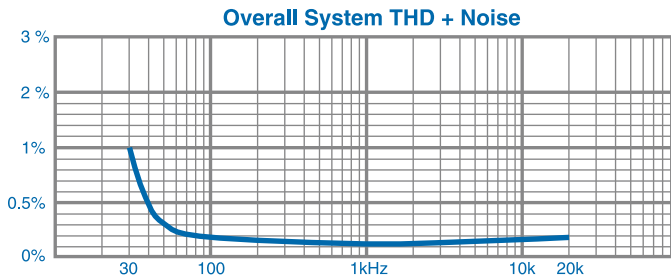

No Pre-Emphasis/De-Emphasis

The Digital Hybrid Wireless® design results in a signal-to-noise ratio high enough to preclude the need for conventional pre-emphasis (HF boost) in the transmitter and de-emphasis (HF roll-off) in the receiver. This eliminates the potential for distortion on signals with abundant high-frequency information.

Low Frequency Roll-Off

The low frequency roll-off can be set for a 3 dB down point at 25, 35, 50, 70, 100, 120 and 150 Hz to control subsonic and very low frequency audio content in the audio. The actual roll-off frequency will vary slightly depending upon the low frequency response of the microphone.

Excessive low frequency content can drive the transmitter into limiting, or in the case of high level sound systems, even cause damage to loudspeaker systems. The roll-off is normally adjusted by ear while listening as the system is operating.

Input Limiter

A DSP-controlled analog audio limiter is employed before the analog-to-digital (A-D) converter. The limiter has a range of more than 30 dB for excellent overload protection. A dual release envelope makes the limiter acoustically transparent while maintaining low distortion. It can be thought of as two limiters in series, a fast attack and release limiter followed by a slow attack and release limiter. The limiter recovers quickly from brief transients, with no audible side effects, and also recovers slowly from sustained high levels, to keep audio distortion low and while preserving short term dynamics.

Signal Encoding and Pilot Tone

In addition to controlling the limiter, the DSP also encodes the digitized audio from the A-D converter and adds an ultrasonic pilot tone to control the receiver's squelch. A pilot tone squelch system provides a reliable method of keeping a receiver output muted (squelched) even in the presence of significant interference.

Control Panel

The control panel includes five membrane switches and an LCD screen to adjust the operational settings. Multi-color LEDs are used to indicate audio signal levels for accurate gain adjustment, battery status and encryption key function.

Alternate Recording Function

The DPR has a built in recording function for use in situations where RF may not be possible or to work as a stand alone recorder. The record function and transmit functions are exclusive of each other - you cannot record AND transmit at the same time. When the unit is transmitting and recording is turned on, the audio in the RF transmission will stop, but the battery status will still be sent to the receiver.

The recorder samples at 44.1kHz rate with a 24 bit sample depth. (the rate was selected due to the required 44.1kHz rate used for the digital hybrid algorithm). The micro SDHC card also offers easy firmware update capabilities without the need for a USB cable or driver issues.

Encryption

When transmitting audio, there are situations where privacy is essential, such as during professional sporting events, in court rooms or private meetings. For instances where your audio transmission needs to be kept secure, without sacrificing audio quality, Lectrosionics introduces Encryption Keys. Truly entropic encryption keys are first created by a Lectrosionics receiver, such as the DSQD Receiver. The key is then synced with the DPR via the IR port. The audio will be encrypted and can only be listened to if both DPR and receiver have the matching encryption key. If you are trying to transmit an audio signal and keys do not match, all that will be heard is silence or white noise.

Features

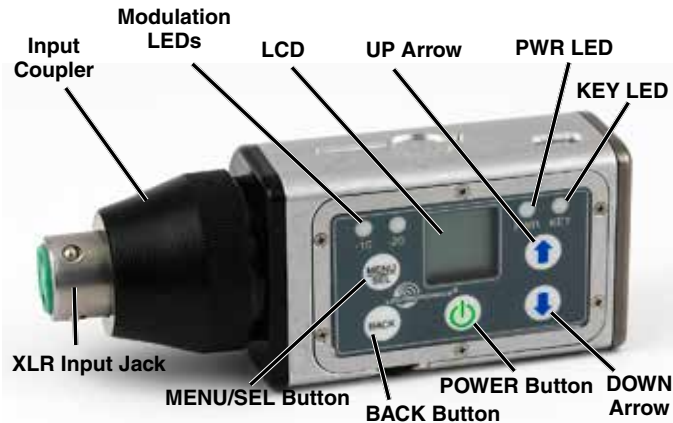

LCD Screen

The LCD is a numeric-type Liquid Crystal Display with several screens that allow settings to be made with the **MENU/SEL** and **BACK** buttons, and the **UP** and **DOWN** arrow buttons to configure the transmitter. The transmitter can be turned on in a “standby” mode with the carrier turned off to make adjustments without the risk of interfering with other wireless systems nearby.

Power LED

The PWR LED glows green when the batteries are charged. The color changes to red when there is about 20 minutes of life left. When the LED begins to blink red, there are only a few minutes of life.

A weak battery will sometimes cause the PWR LED to glow green immediately after being put into the unit, but will soon discharge to the point where the LED will go red or shut off completely.

Key LED

The blue Key LED will blink if an encryption key is not set and “no key” will blink on LCD. The Key LED will remain on if the encryption is set correctly and will turn off in Standby mode.

Modulation LEDs

The Modulation LEDs provide a visual indication of the input audio signal level from the microphone. These two bicolor LEDs can glow either red or green to indicate modulation levels. Full modulation (0 dB) occurs when the -20 LED first turns red.

Signal Level	-20 LED	-10 LED
Less than -20 dB	● Off	● Off
-20 dB to -10 dB	● Green	● Off
-10 dB to +0 dB	● Green	● Green
+0 dB to +10 dB	● Red	● Green
Greater than +10 dB	● Red	● Red

MENU/SEL Button

The **MENU/SEL** button is used to display the transmitter menu items. Press once to open the menu, then use the **UP** and **DOWN** arrows to scroll menu items. Press **MENU/SEL** again to choose an option from the menu.

BACK Button

Once a selection is made in a menu, press the **BACK** Button to save your selection and go back to the previous menu.

UP/DOWN Arrow Buttons

The **UP** and **DOWN** arrow buttons are used to scroll through menu options.

From the Main Screen, use the **UP** Arrow to turn the LEDs on and the **DOWN** Arrow to turn the LEDs off.

Audio Input Jack

The XLR input jack on the transmitter accommodates hand-held, shotgun and measurement microphones. Phantom power can be set at various levels for use with a wide variety of electret microphones.

Antenna

An antenna is formed between the housing and the attached microphone, operating much like a dipole. At UHF frequencies the length of the housing is similar to 1/4 wavelength of the operating frequency, so the antenna is surprisingly efficient, which helps extend the operating range and suppress noise and interference.

IR (infrared) Port

The IR port is available on the side of the transmitter for quick setup using a receiver with this function available. IR Sync will transfer the settings for frequency from the receiver to the transmitter.



Battery Installation

The battery compartment door is made of machined aluminum and is hinged to the housing to prevent it being damaged or lost.

The transmitter is powered by two AA batteries (lithium recommended).

Note: Standard zinc-carbon batteries marked “heavy-duty” or “long-lasting” are not adequate.



Batteries operate in series, with a connecting plate built into the battery door

To install new batteries:

1. Slide open the Battery Cover and remove any old batteries.
2. Insert the new batteries into the housing. One battery goes in positive (+) end first, the other negative (-) end first. Look into the battery compartment to determine which end goes in which side. The side with the circular insulator is the side which accepts the positive end of the battery.

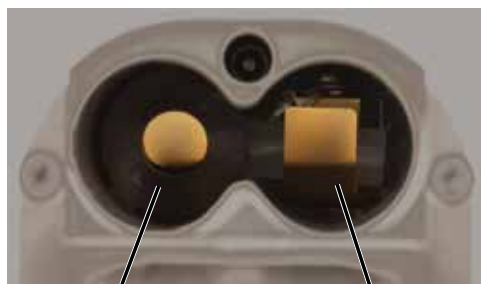

positive (+)
terminal

negative (-)
terminal

Note: It is possible to install the batteries backward and close the battery door, but the batteries will not make contact and the unit will not power up.

3. Slide the Battery Cover until it snaps securely shut.

Attaching/Removing a Microphone

The spring loaded coupler under the XLR jack maintains a secure fit to the microphone jack with continuous pressure applied by an internal spring.

To attach the microphone, simply align the XLR pins and press the microphone onto the transmitter until the coupler retracts and latches. A click sound will be heard as the connector latches.

To remove the microphone, hold the transmitter body in one hand with the microphone pointing upward. Use your other hand to rotate the coupler until the latch releases and the coupler rises slightly.

Do not pull on the microphone while releasing the locking collar.

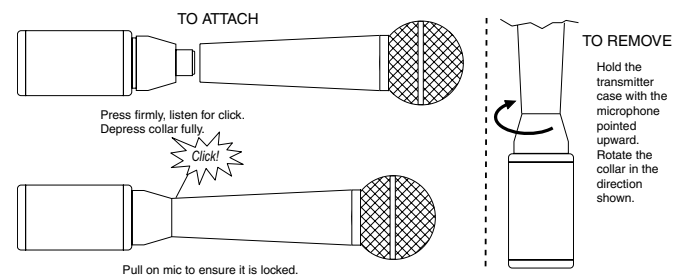

NOTE: Do not hold or apply any pressure to the microphone body while trying to remove it, as this may prevent the latch from releasing.

Operating Instructions



- Have the user talk or sing at the same level that will be used in the production, and adjust the input gain so that the **-20 LED blinks red on louder peaks**.

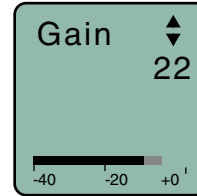
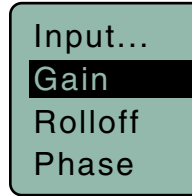

Use the UP and DOWN arrow buttons to adjust the gain until the -20 LED blinks red on louder peaks

Turning Power ON

Short Button Press

When the unit is turned off, a short press of the power button (⏻) will turn the unit on in the Standby Mode with the RF output turned off.

RF indicator blinks

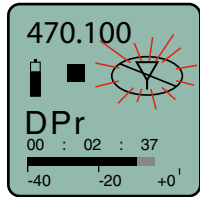

Long Button Press

When the unit is turned off, a long press of the power button (⏻) will start a countdown to turn the unit on with the RF output turned on. Continue to hold the button until the countdown is complete.

RF indicator not blinking



Hold power button until the counter reaches 3

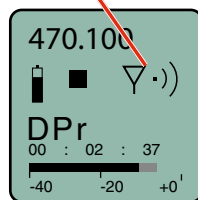

If the button is released before the countdown is completed, the unit will power up with the RF output turned off (standby).

Signal Level	-20 LED	-10 LED
Less than -20 dB	● Off	● Off
-20 dB to -10 dB	● Green	● Off
-10 dB to +0 dB	● Green	● Green
+0 dB to +10 dB	● Red	● Green
Greater than +10 dB	● Red	● Red

- Set the frequency to match the receiver.
- Turn the power off and then back on while holding the power button in and waiting for the counter to reach 3.

Recorder Operating Instructions

- Install battery(s)
- Insert microSDHC memory card
- Turn power on
- Format memory card
- Connect microphone and place it in the position where it will be used.
- Have the user talk or sing at the same level that will be used in the production, and adjust the input gain so that the **-20 LED blinks red on louder peaks**.

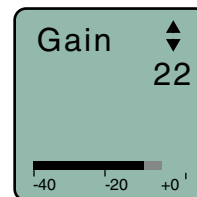
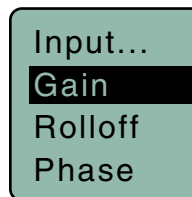

Use the UP and DOWN arrow buttons to adjust the gain until the -20 LED blinks red on louder peaks

Transmitter Operating Instructions

- Install battery(s)
- Turn power on in the Standby mode (see previous section)
- Connect microphone and place it in the position where it will be used.

Signal Level	-20 LED	-10 LED
Less than -20 dB	● Off	● Off
-20 dB to -10 dB	● Green	● Off
-10 dB to +0 dB	● Green	● Green
+0 dB to +10 dB	● Red	● Green
Greater than +10 dB	● Red	● Red

- Press MENU/SEL, choose SDCard and Record from the menu



- To stop recording, press MENU/SEL, choose SDCard and Stop; the word SAVED appears on the screen



Memory Card Preparation

Compatible Cards

We have tested a wide variety of microSDHC memory cards and these performed the best with no issues or errors.

- Lexar 16GB High Performance UHS-I (Lexar part number LSDMI16GBBNL300).
- SanDisk 16GB Extreme PLUS UHS-I (SanDisk part number SDSDQX-016G-GN6MA)
- Sony 16GB UHS-I (Sony part number SR16UXA/TQ)
- PNY Technologies 16GB Elite UHS-1 (PNY part number P-SDU16U185EL-GE)
- Samsung 16GB PRO UHS-1 (Samsung part number MB-MG16EA/AM)

Formatting Card

microSDHC memory cards come pre-formatted with a FAT32 file system which is optimized for good performance. The DPR relies on this performance and will never disturb the underlying low level formatting of the SD card. When the DPR “formats” a card, it performs a function similar to the Windows “Quick Format” which deletes all files and prepares the card for recording.

The card can be read by any standard computer but if any write, edit or deletions are made to the card by the computer, the card must be re-formatted with the DPR to prepare it again for recording. The DPR never low level formats a card and we strongly advise against doing so with the computer.

When a card is installed, or when the DPR is powered on with a card already installed, the card is scanned to see if it has been formatted for use with the DPR. If it hasn't, a prompt appears offering to do so. Follow the on-screen prompts to format the card. If the scan finds an interrupted recording, the Recovery screen will appear. The formatting operation may also be performed on a card which is already formatted, to erase all recordings and start over with an empty card. To do this, select Format Card from the menu.

WARNING: DO NOT PERFORM A LOW LEVEL FORMAT (COMPLETE FORMAT) WITH A COMPUTER. DOING SO MAY RENDER THE MEMORY CARD UNUSABLE WITH THE DPR RECORDER. WITH A WINDOWS BASED COMPUTER, BE SURE TO CHECK THE QUICK FORMAT BOX BEFORE FORMATTING THE CARD. WITH A MAC, CHOOSE MS-DOS (FAT) IF THE CARD IS 32 GB OR SMALLER, EXFAT IF CARD IS 64+ GB.

IMPORTANT

The formatting of the DPR SD card sets up contiguous sectors for maximum efficiency in the recording process. The file format utilizes the iXML wave format which has sufficient data space in the header for the file information and the time code imprint.

The SD card, as formatted by the DPR, can be corrupted by any attempt to directly edit, change, format or view the files on a computer.

The simplest way to prevent data corruption is to copy the .wav files from the card to a computer or other Windows or OS formatted media **FIRST. Repeat – COPY THE FILES FIRST!**

Do not rename files directly on the SD card.

Do not attempt to edit the files directly on the SD card.

Do not save **ANYTHING** to the SD card with a computer (such as the take log, note files etc) - it is formatted for DPR use only.

In short - there should be NO manipulation of the data on the card or addition of data to the card with anything other than a DPR. Copy the files to a computer, thumb drive, hard drive etc that has been formatted as a regular OS device **FIRST** - then you can edit freely.

iXML HEADER SUPPORT

Recordings contain industry standard iXML chunks in the file headers, with the most commonly used fields filled in.

DPR Menu

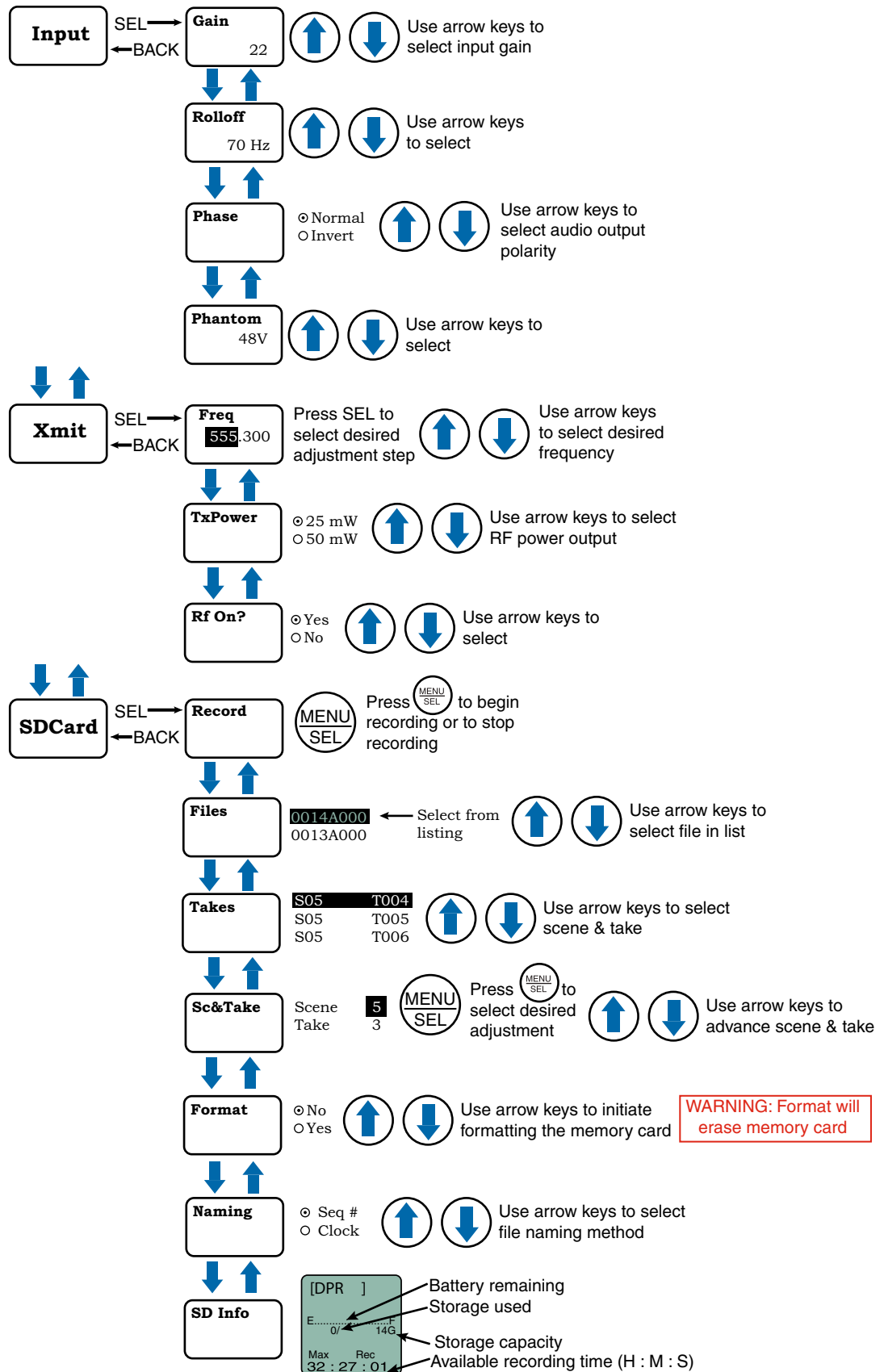

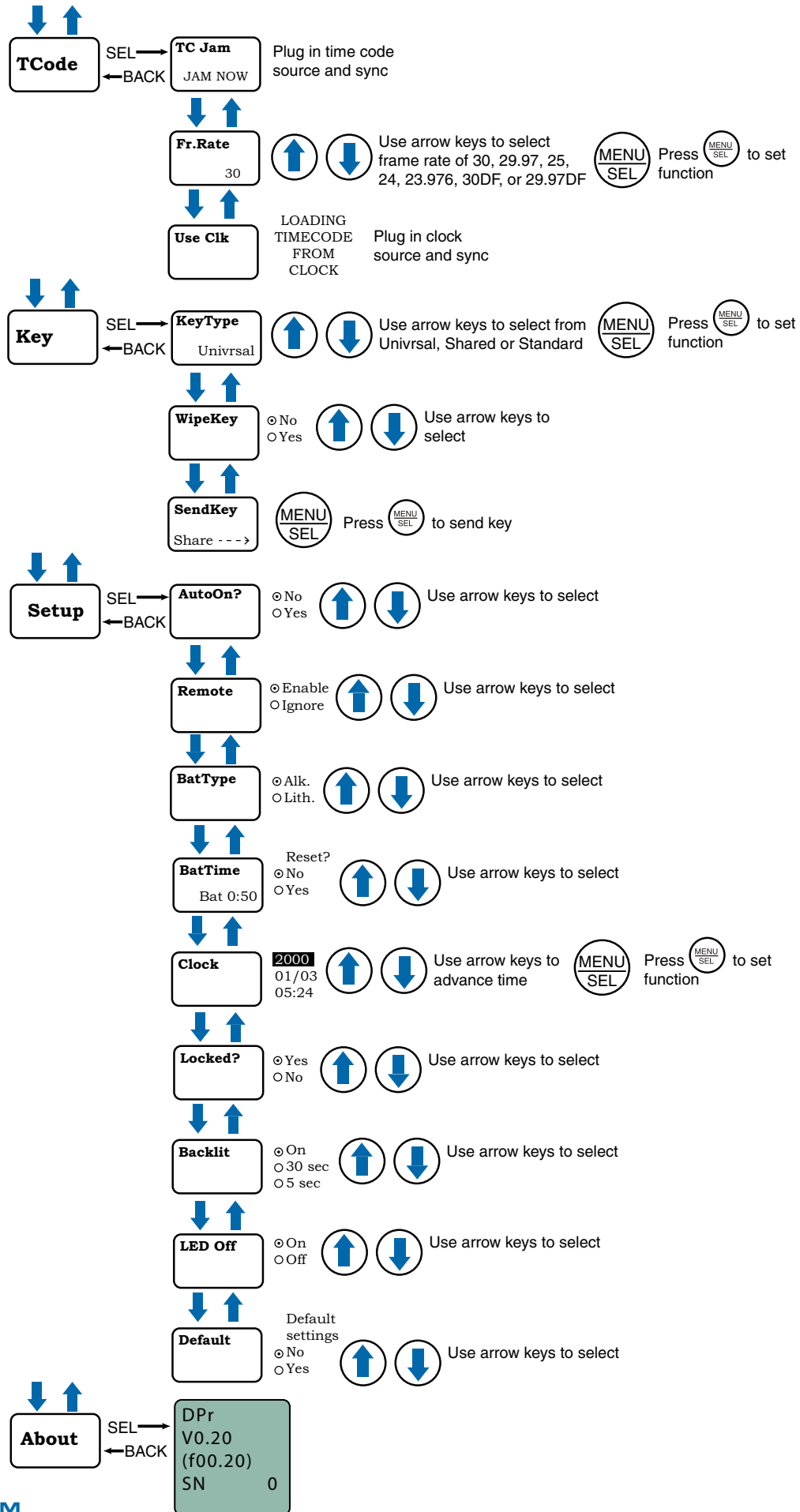

Setup Screen Details

Main Window Indicators

The Main Window displays the operating frequency, Standby or Operating mode, battery status, if an SDHC card is present/recording, and audio level.

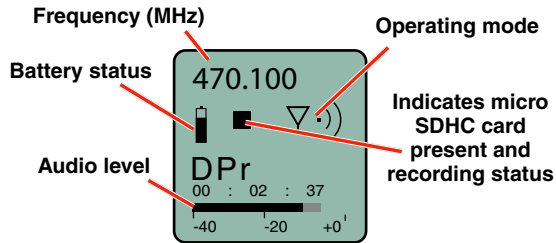

Connecting the Signal Source

Microphones, line level audio sources, and instruments can be used with the transmitter. Refer to the section entitled **Input Jack Wiring for Different Sources** for details on the correct wiring for line level sources and microphones to take full advantage of the Servo Bias circuitry.

Turning Control Panel LEDs ON/OFF

From the main menu screen, a quick press of the UP arrow button turns the control panel LEDs on. A quick press of the DOWN arrow button turns them off. The buttons will be disabled if the LOCKED option is selected in the Setup menu.

The control panel LEDs can also be turned on and off with the **LED Off** option in the Setup menu.

Helpful Features on Receivers

To aid in finding clear frequencies, several Lectrosonics receivers offer a **SmartTune** feature that scans the tuning range of the receiver and displays a graphical report that shows where RF signals are present at different levels, and areas where there is little or no RF energy present. The software then automatically selects the best channel for operation.

Lectrosonics receivers equipped with an **IR Sync** function allow the receiver to set frequency on the transmitter via an infrared link between the two units.

Input Menu

Adjusting the Input Gain

The two bicolor Modulation LEDs on the control panel provide a visual indication of the audio signal level entering the transmitter. The LEDs will glow either red or green to indicate modulation levels as shown in the following table.

Signal Level	-20 LED	-10 LED
Less than -20 dB	● Off	● Off
-20 dB to -10 dB	● Green	● Off
-10 dB to +0 dB	● Green	● Green
+0 dB to +10 dB	● Red	● Green
Greater than +10 dB	● Red	● Red

NOTE: Full modulation is achieved at 0 dB, when the "-20" LED first turns red. The limiter can cleanly handle peaks up to 30 dB above this point.

It is best to go through the following procedure with the transmitter in the standby mode so that no audio will enter the sound system or recorder during adjustment.

- 1) With fresh batteries in the transmitter, power the unit on in the standby mode (see previous section **Turning Power ON and OFF**).
- 2) Navigate to the Gain setup screen.

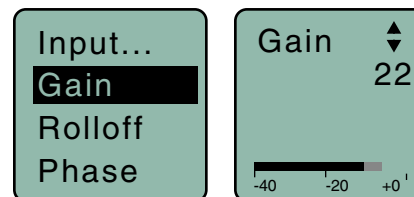

- 3) Prepare the signal source. Position a microphone the way it will be used in actual operation and have the user speak or sing at the loudest level that will occur during use, or set the output level of the instrument or audio device to the maximum level that will be used.
- 4) Use the ⬆ and ⬇ arrow buttons to adjust the gain until the **-10 dB** glows green and the **-20 dB** LED starts to flicker red during the loudest peaks in the audio.
- 5) Once the audio gain has been set, the signal can be sent through the sound system for overall level adjustments, monitor settings, etc.
- 6) If the audio output level of the receiver is too high or low, use only the controls on the receiver to make adjustments. Always leave the transmitter gain adjustment set according to these instructions, and do not change it to adjust the audio output level of the receiver.

Selecting the Low Frequency Roll-off

It is possible that the low frequency roll-off point could affect the gain setting, so it's generally good practice to make this adjustment before adjusting the input gain. The point at which the roll-off takes place can be set to:

- 25 Hz
- 35 Hz
- 50 Hz
- 70 Hz
- 100 Hz
- 120 Hz
- 150 Hz

The roll-off is often adjusted by ear while monitoring the audio.

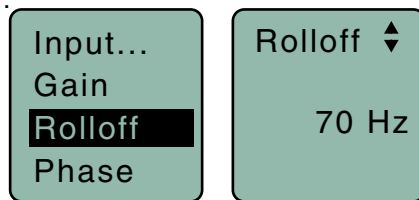

Selecting Audio Polarity (Phase)

Audio polarity can be inverted at the transmitter so the audio can be mixed with other microphones without comb filtering. The polarity can also be inverted at the receiver outputs.

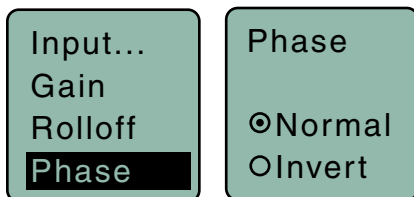

Selecting Phantom Power Supply

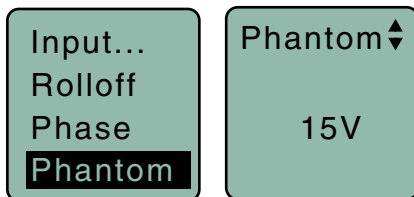

The transmitter input jack can provide phantom power for the attached microphone if needed, with voltages at 5, 15 or 48. Phantom power will consume a slight amount of battery power, so it can also be turned off.

About the Phantom Power Supply

Three phantom voltages are selectable from the control panel. The voltages are:

- **5 Volts** for lavalier microphones,
- **15 Volts** for some professional mics requiring high current and for many common stage mics that will operate over a wide phantom Voltage range of 12 to 48 Volts. With the proper adapter, this position can also be used with T power microphones. See our web site for details on finding or making the proper adapter.
- **48 Volts** for microphones that do in fact require a supply greater than 18 Volts. (See below for a discussion of why 42 and not a "true" 48 Volts.)

For longest battery life use the minimum phantom voltage necessary for the microphone. Many stage microphones regulate the 48 Volts down to 10 Volts internally anyway, so you might as well use the 15 Volt setting and save some battery power. If you are not using a microphone for the input device, or are using a microphone that does not require phantom power, turn the phantom power off.

Phantom power should only be used with a fully floating, balanced device, such as common microphones with a 3-pin XLR connector. If you use the phantom power with an unbalanced device or if pins 2 or 3 are DC connected to ground, then you will draw maximum current from the power supply. The HM is fully protected against such shorts but the batteries will be drained at twice the normal rate.

The transmitter can supply 4 mA at 42 Volts, 8 mA at 15 Volts, and 8 mA at 5 Volts. The 42 Volts setting actually supplies the same voltage to a 48 Volt microphone as the DIN standard arrangement due to a dynamic biasing scheme that does not have as much voltage drop as the DIN standard. The 48 Volt DIN standard arrangement protects against shorts and high fault current with high resistance in the power supply feeds to pins 2 and 3. This provides protection if the supply current is accidentally shorted to ground and also keeps the microphone from being attenuated by the power supply.

The DPR improves on those functions and is able to use less power from the battery by using constant current sources and current limiters. With this dynamic arrangement, the DPR can also supply more than twice the current of competing 48 Volt plug on units and provide four times the current for some very high end 15 Volt microphones.

Xmit Menu

Selecting Frequency

The setup screen for frequency selection offers two ways to browse the available frequencies.

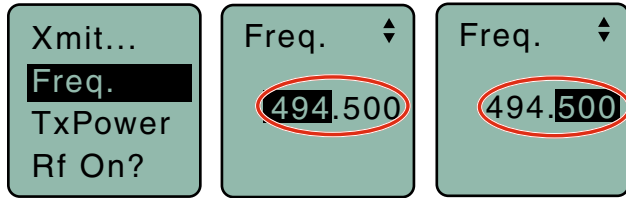

Press the MENU/SEL button to select each field. Use the \uparrow and \downarrow arrow buttons to adjust the frequency. Each field will step through the available frequencies in a different increment.

Setting Transmitter Output Power

The output power can be set to 25 mW or 50 mW.

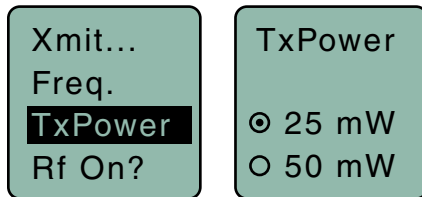

Turning Rf Output On

It's best to set frequency and other settings in the standby mode (Rf off) so that no audio will enter the sound system or recorder during adjustment. Use this menu item to turn the Rf On and Off.

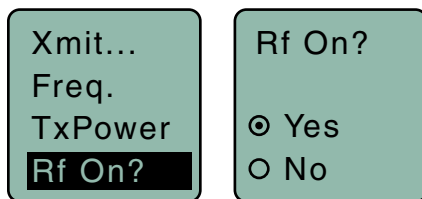

NOTE: See previous section, *Turning Power ON and OFF* for instructions on turning transmitter on in with the Rf off (Standby Mode).

SDCard Menu

Record or Stop

Begins recording or stops recording. (See Recorder Operating Instructions.)

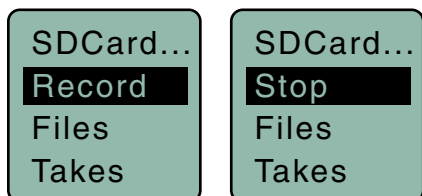

Choosing Files for Replay

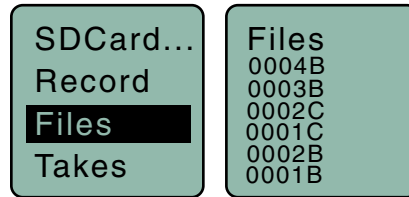

Select recorded files on microSDHC memory card.

Choosing Takes for Replay

Use UP and DOWN arrows to toggle and MENU/SEL to play back.

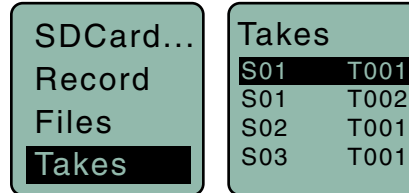

Setting Scene and Take Number

Use UP and DOWN arrows to advance Scene and Take and MENU/SEL to toggle. Press the BACK button to return to menu.

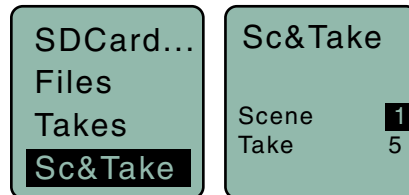

Formatting microSDHC Memory Card

Formats the microSDHC memory card.

WARNING: This function erases any content on the microSDHC memory card.

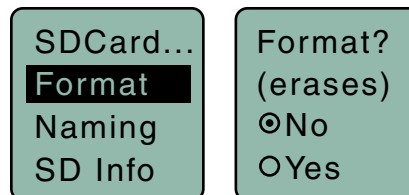

Recorded File Naming

Choose to name the recorded files by the sequence number, by the clock time or by scene and take.

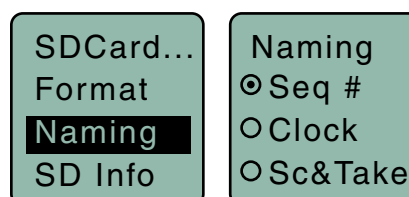

microSDHC Memory Card Info

Information regarding the microSDHC memory card including space remaining on card.

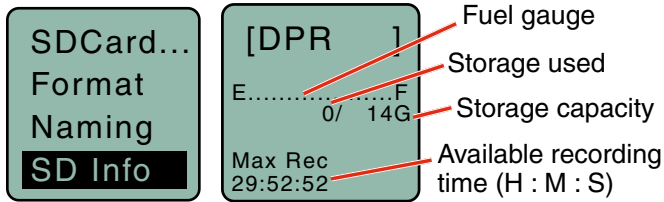

Use Clock

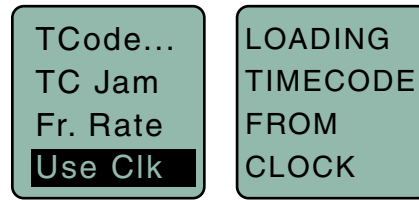

Choose to use the clock provided in the DPR as opposed to a timecode source. Set the clock in the Settings Menu, Date & Time.

NOTE: The DPR time clock and calendar (RTCC) cannot be relied on as an accurate time code source. Use Clock should only be used in projects where there is no need for the time to agree with an external time code source.

TCode Menu

TC Jam (jam timecode)

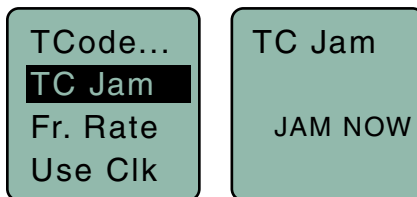

When TC Jam is selected, **JAM NOW** will blink on the LCD and the unit is ready to be synced with the timecode source. Connect the timecode source and the sync will take place automatically. When the sync is successful, a message will be displayed to confirm the operation.

Timecode defaults to zero at power up if no timecode source is used to jam the unit. A timing reference is logged into the BWF metadata.

Setting Frame Rate

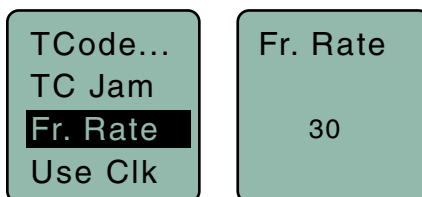

The frame rate affects embedding of the timing reference in the .BWF file metadata and display of timecode. The following options are available:

- 30
- 23.976I
- 29.97
- 30DF
- 25
- 29.97DF
- 24

NOTE: While it is possible to change the frame rate, the most common use will be to check the frame rate which was received during the most recent timecode jam. In rare situations, it might be useful to alter the frame rate here, but be aware that audio tracks may not line up correctly with mismatched frame rates.

Key Menu

KeyType

The DPR receives an encryption key via the IR port from a key generating receiver. Begin by selecting a key type in the receiver and generating a new key (key type is labeled KEY POLICY in the DSQD receiver). Set the matching KEY TYPE in the DPR and transfer the key from the receiver (SYNC KEY) to the DPR via the IR ports. A confirmation message will display on the receiver display if the transfer is successful. The transmitted audio will then be encrypted and can only be listened to if the receiver has the matching encryption key.

The DPR has three options for encryption keys:

- **Standard:** This is the highest level of security. The encryption keys are unique to the receiver and there are only 256 keys available to be transferred to a transmitter. The receiver tracks the number of keys generated and the number of times each key is transferred.
- **Shared:** There are an unlimited number of shared keys available. Once generated by a receiver and transferred to the DPR, the encryption key is available to be shared (synced) by the DPR with other transmitters/receivers via the IR port. When a transmitter is set to this key type, a menu item named SEND KEY is available to transfer the key to another device.
- **Universal:** This is the most convenient encryption option available. All encryption-capable Lectrosonics transmitters and receivers contain the Universal Key. The key does not have to be generated by a receiver. Simply set the DPR and a Lectrosonics receiver to Universal, and the encryption is in place. This allows for convenient encryption amongst multiple transmitters and receivers, but not as secure as creating a unique key.

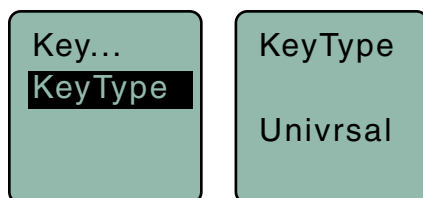

WipeKey

This menu item is only available if Key Type is set to Standard or Shared. Select Yes to wipe the current key and enable the DPR to receive a new key.

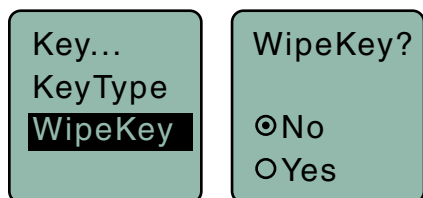

SendKey

This menu item is only available if Key Type is set to Shared. Press Menu/Sel to sync the Encryption key to another transmitter or receiver via the IR port.

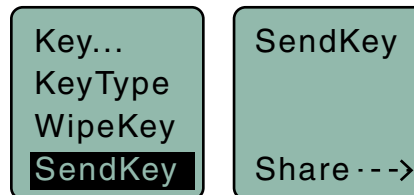

Setup Menu

Setting Auto On

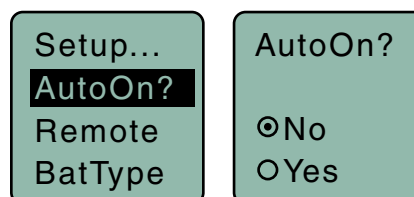

Selects whether or not the unit will turn on automatically after a battery change.

Enabling Remote Function

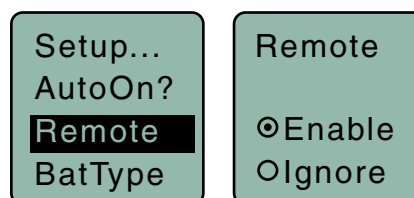

The DPR can be configured to respond to “dweedle tone” signals from the LectroRM smart phone app or to ignore them. Use the arrow buttons to toggle between “yes” (remote control on) and “no” (remote control off). (See section on LectroRM.)

Setting Battery Type

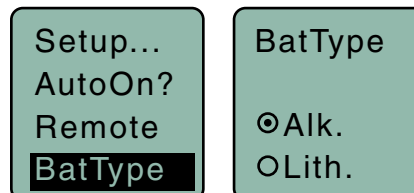

Choose either Alkaline (recommended) or Lithium AA battery type. The voltage of the installed battery pair will be shown at the bottom of the display.

Setting Battery Timer

A built-in timer can be used with any battery type, but it is especially valuable with rechargeable batteries such as NiMH types. The voltage remains fairly constant across the discharge time of a rechargeable battery, then drops quickly near the end of the operating time. The most accurate way to determine runtime status is by testing the time provided by a particular battery brand and type, then using the timer to determine remaining runtime. Rechargeable batteries lose capacity over their life, so it is good to run the battery down and note the runtime on older or unfamiliar batteries.

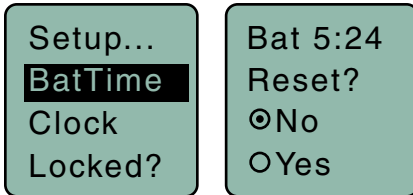

Setting Date and Time (Clock)

To set the date and time, use the MENU/SEL button to toggle through the fields and the UP and DOWN arrow buttons to choose the appropriate number.

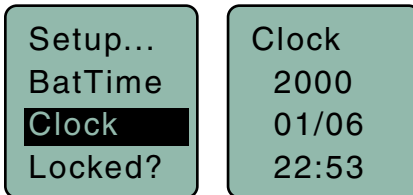

Locking/Unlocking Settings

Changes to the settings can be locked to prevent inadvertent changes being made.

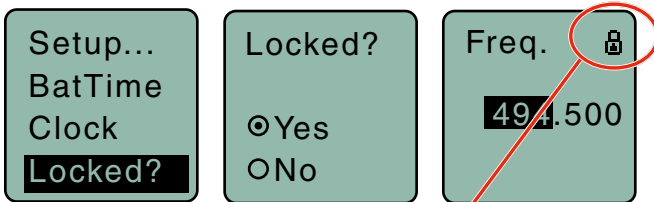

A small padlock symbol will appear on adjustment screens when changes have been locked.

When changes are locked, several controls and actions can still be used:

- Settings can still be unlocked
- Menus can still be browsed

Backlit Settings

Sets the duration of the LCD backlight.

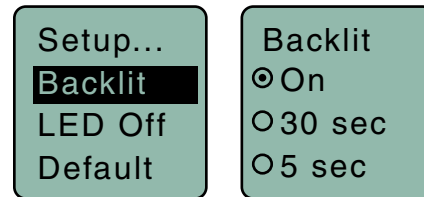

Turn LEDs On/Off

Enables/disables control panel LEDs.

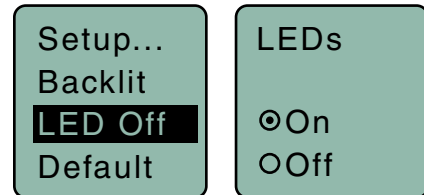

NOTE: LEDs can also be turned off/on from the control panel. From the main screen, a quick press of the UP arrow button turns the control panel LEDs on. A quick press of the DOWN arrow button turns them off.

Restoring Default Settings

This is used to restore the factory settings.

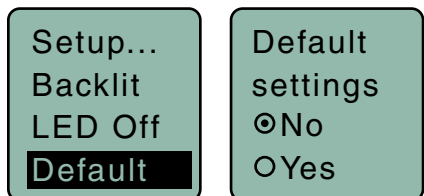

About

Displays the DPR model number and firmware version.

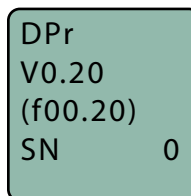

LectroRM

By New Endian LLC

LectroRM is a mobile application for iOS and Android operating systems. Its purpose is to remotely control Lectrosonics Transmitters, including:

- SM Series
- WM
- L Series
- DPR

The app remotely changes settings on the transmitter through the use of encoded audio tones, which when received by the attached microphone, will alter the configured setting. The app was released by New Endian, LLC in September 2011. The app is available for download and sells for \$20 on the Apple App Store and Google Play Store.

LectroRM's remote control mechanism is the use of an audio sequence of tones (dweedles) that are interpreted by the transmitter as a configuration change. The settings available in LectroRM are:

- Audio Level
- Frequency
- Sleep Mode
- Lock Mode

User Interface

The user interface involves selecting the audio sequence related to the desired change. Each version has an interface for selecting the desired setting and the desired option for that setting. Each version also has a mechanism to prevent accidental activation of the tone.

iOS



The iPhone version keeps each available setting on a separate page with the list of options for that setting. On iOS, the "Activate" toggle switch must be enabled to show the button which will then activate the audio. The iOS version's default orientation is upside-down but can be configured to orient right-side up. The purpose for this is to orient the device's speaker, which is at the bottom of the device, closer to the transmitter microphone.

Android

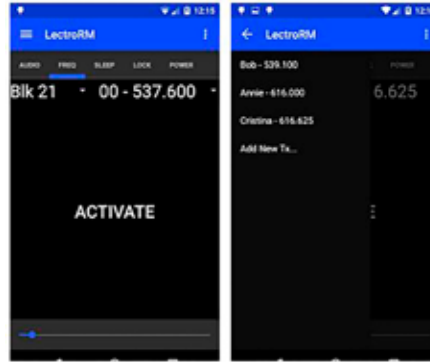

The Android version keeps all settings on the same page and allows the user to toggle between the activation buttons for each setting. The activation button must be long pressed to activate. The Android version also allows users to keep a configurable list of full sets of settings.

Activation

For a transmitter to respond to remote control audio tones, the transmitter must meet certain requirements:

- The transmitter must not be turned off; it can however be in sleep mode.
- The transmitter must have firmware version 1.5 or later for Audio, Frequency, Sleep and Lock changes.
- The transmitter microphone must be within range.
- The transmitter must be configured to enable remote control activation.

Please be aware this app is not a Lectrosonics product. It is privately owned and operated by New Endian LLC, www.newendian.com.

Accessories

21750 Barrel Adapter



Mic adapter for Earthworks M30 microphone with HM, DPR and UH400a/TM transmitters.

This polarity reversing adapter may be needed to correct for asymmetrical current draw in some P48 powered condenser microphones, including older Neumann 100 Series, Rode NTG3 and others. If your microphone does not power on correctly when used with these transmitters, insert the adapter between the transmitter and microphone.

MCA-M30 Barrel Adapter



This adapter may be needed if you are experiencing noise or distortion with measurement microphones, particularly the Earthworks M30. The adapter has a common mode choke for suppressing RF noise. If your microphone signal exhibits the problems listed above when connected to a UH400, HM or DPR transmitter, insert the adapter between the microphone and the transmitter.

Insert the adapter between the transmitter and microphone to alleviate the problems listed above.

PHTRAN3

Replacement leather pouch with clear plastic screen cover, rotating belt clip and snap closure. Included with transmitter at purchase.



MCA5X

This is an optional adapter for connecting a lavalier microphone to the DPR or HM transmitters. TA5M to XLR3-M connectors. Passes transmitter phantom power to bias the electret lavalier microphone. Includes zener protection to limit bias voltage to protect the microphone if transmitter phantom power is set too high.



MCA-TPOWER

This cable adapter is to be used with the UH200D, UH400, HM and DPR plug-on transmitters with T-powered microphones. It will protect a T-power mic against the 48V phantom power setting in the transmitter while allowing normal operation. The transmitter should be set to the 15V position for best operation and minimum battery drain.



Specifications and Features

Transmitter

Operating Frequencies:	470.100 - 607.950 MHz
Frequency Selection Steps:	25 kHz
RF Power output:	Selectable 25/50 mW
Frequency stability:	± 0.002%
Digital modulation:	8PSK
Spurious radiation:	Compliant with ETSI EN 300 422-1 v1.4.2
Equivalent input noise:	-125 dBV
Input level:	Nominal 2 mV to 300 mV, before limiting Greater than 1V maximum, with limiting
Input impedance:	1K Ohm
Input limiter:	Dual envelope type; 30 dB range
Gain control range:	55 dB in 1 dB steps; digital control
Modulation indicators:	<ul style="list-style-type: none"> Dual bi-color LEDs indicate modulation of -20, -10, 0, +10 dB referenced to full modulation LCD bar graph
Audio Performance (overall system):	
Frequency Response:	20 Hz to 20 kHz (+/-1dB);
Low frequency Roll-off:	Adjustable for -3dB @20, 35, 50, 70, 100, 120 or 150 Hz
THD:	0.2% (typ. 100 Hz to 20 kHz - see graph)
Input Dynamic Range:	125 dB (with full Tx limiting)
Controls & Indicators:	<ul style="list-style-type: none"> Power/Phantom "ON-OFF" Phantom voltage selector Audio input gain LCD w/membrane switches LED audio level indicators
Audio Input Jack:	Standard 3-pin XLR (female)
Phantom Power:	5V @ 18 mA max., 15V @ 15 mA max. and 48 V @ 4 mA max., plus "OFF"
IR (infrared) port: from	For quick setup by transferring settings from an IR enabled receiver
Antenna:	Housing and attached microphone form the antenna
Battery:	Two 1.5 Volt AA (lithium recommended)
Battery Life:	
AA lithium; No Phantom Power:	6h 0m*
AA lithium; 48V Phantom Power:	3h 30m**
	*Tested with a dynamic microphone **Tested with a Sanken CS1 for a phantom-powered microphone
Weight:	7.8 ozs. (221 grams)
Dimensions:	4.21" L x 1.62" W x 1.38" H
Emission Designator:	170KG1E

Recorder

Storage media:	microSDHC memory card
File format:	.wav files (BWF)
A/D converter:	24-bit
Sampling rate:	48 kHz
Recording modes/Bit rate:	<ul style="list-style-type: none"> HD mono mode: 24 bit - 144 kb/s
Input	
Type:	Analog mic/line level compatible; servo bias preamp for 2V and 4V lavalier microphones
Level:	<ul style="list-style-type: none"> Dynamic mic: 0.5 mV to 50 mV Electret mic: Nominal 2 mV to 300 mV Line level: 17 mV to 1.7 V
Input connector:	TA5M 5-pin male
Audio Performance	
Frequency response:	20 Hz to 20 kHz; +0.5/-1.5 dB
Dynamic range:	110 dB (A), before limiting
Distortion:	< 0.035%
Operating temperature range	
Celsius:	-20 to 50
Fahrenheit:	-5 to 122

Firmware Update

Firmware updates are made using a microSDHC memory card. Download and copy the following firmware update files to a drive on your computer.

- **dpr vX_xx.ldr** is the firmware update file, where "X_xx" is the revision number.

In the computer:

- 1) Perform a **Quick Format** of the card. On a Windows-based system, this will automatically format the card to the FAT32 format, which is the Windows standard. On a Mac, you may be given several options. If the card is already formatted in Windows (FAT32) - it will be greyed out - then you do not need to do anything. If the card is in another format, choose Windows (FAT32) and then click "Erase". When the quick format on the computer is complete, close the dialogue box and open the file browser.
- 2) Copy the **dpr vX_xx.ldr** file to the memory card, then safely eject the card from the computer.

In the DPR:

- 1) Leave the DPR turned off and insert the microSDHC memory card into the slot.
- 2) Hold down both the UP and DOWN arrow buttons on the control panel and turn the power on.
- 3) The transmitter will boot up into the firmware update mode with the following options on the LCD:
 - **Update** - Displays a scrollable list of the .ldr files on the card.
 - **Power Off** - Exits the update mode and turns the power off.

NOTE: If the unit screen shows **FORMAT CARD?**, power the unit off and repeat step 2. You were not properly pressing UP, DOWN and Power at the same time.

- 4) Use the arrow buttons to select **Update**. Use the UP and DOWN arrow buttons to select the desired file and press MENU/SEL to install the firmware. The LCD will display status messages while the firmware is being updated.
- 5) When the update is complete, the LCD will display this message: **UPDATE SUCCESSFUL REMOVE CARD**. Open the battery door and remove the memory card.
- 6) Re-attach the battery door and power the unit back on. Verify that the firmware version was updated by opening the Power Button Menu and navigating to the **About** item.

- 7) If you re-insert the update card and turn the power back on for normal use, the LCD will display a message prompting you to format the card:

Format Card? (files lost)

- No
- Yes

If you wish to record audio on the card, you must re-format it. Select **Yes** and press MENU/SEL to format the card. When the process is complete, the LCD will return to the Main Window and be ready for normal operation.

If you choose to keep the card as is, you may remove the card at this time.

The firmware update process is managed by a bootloader program - on very rare occasions, you might need to update the bootloader.

WARNING: Updating the bootloader can corrupt your unit if interrupted. Don't update the bootloader unless advised to do so by the factory.

- **dpr_boot vX_xx.ldr** is the bootloader file

Follow the same process as with a firmware update and select the dprboot file.

Recovery Process

In the event of a battery failure while the unit is recording, a recovery process is available to restore the recording in proper format. When a new battery is installed and the unit is turned back on, the recorder will detect the missing data and prompt you to run the recovery process. **The file must be recovered or the card will not be usable in the DPR.**

First it will read:

**Interrupted Recording
Found**

The LCD message will ask:

**Recover?
for safe use
see manual**

You will have the choice of **No** or **Yes** (No is selected as the default). If you wish to recover the file, use the DOWN arrow button to select **Yes**, then press MENU/SEL.

The next window will give you the option to recover all or part of the file. The default times shown are the best guess by the processor where the file stopped recording. The hours will be highlighted and you can either accept the value shown or select a longer or shorter time. If you are unsure, simply accept the value shown as the default.

Press MENU/SEL and the minutes are then highlighted. You can increase or decrease the time to be recovered. In most cases you can simply accept the values shown and the file will be recovered. After you have made your time choices, press MENU/SEL again. A small **GO!** symbol will appear next to the DOWN arrow button. Pressing the button will initiate the file recovery. The recovery will happen quickly and you will see:

**Recovery
Successful**

Special Note:

Files under 4 minutes long may recover with additional data “tacked on” to the end of the file (from previous recordings or data if the card had been used previously). This can be effectively eliminated in post with a simple delete of the unwanted extra “noise” at the end of the clip. The minimum recovered length will be one minute. For example, if the recording is only 20 seconds long, and you have selected one minute there will be the desired 20 recorded seconds with an additional 40 seconds of other data and or artifacts in the file. If you are uncertain about the length of the recording you can save a longer file - there will simply be more “junk” at the end of the clip. This “junk” may include audio data recorded in earlier sessions that were discarded. This “extra” information can be easily deleted in post production editing software at a later time.

ISED Notices:

Per RSS-210

This device operates on a no-protection no-interference basis. Should the user seek to obtain protection from other radio services operating in the same TV bands, a radio licence is required. Please consult Industry Canada’s document CPC-2-1-28, Optional Licensing for Low-Power Radio Apparatus in the TV Bands, for details.

Ce dispositif fonctionne selon un régime de non-brouillage et de non-protection. Si l'utilisateur devait chercher à obtenir une certaine protection contre d'autres services radio fonctionnant dans les mêmes bandes de télévision, une licence radio serait requise. Pour en savoir plus, veuillez consulter le document CPC-2-1-28 d'Industrie Canada intitulé, Délivrance de licences sur une base volontaire pour les appareils radio de faible puissance exempts de licence et exploités dans les bandes de télévision.

Per RSS-Gen

This device complies with Industry Canada’s license-exempt RSSs. Operation is subject to the following two conditions:

- 1) *This device may not cause interference*
- 2) *This device must accept any interference, including interference that may cause undesired operation of the device.*

Le présent appareil est conforme aux CNR d'Industrie Canada applicables aux appareils radio ex-empts de licence. L'exploitation est autorisée aux deux conditions suivantes :

- 1) *l'appareil ne doit pas produire de brouillage;*
- 2) *l'appareil doit accepter tout brouillage radioélectrique subi, même si le brouillage est susceptible d'en compromettre le fonctionnement.*

This device complies with part 15 of the FCC Rules. Operation is subject to the following two conditions: (1) This device may not cause harmful interference, and (2) this device must accept any interference received, including interference that may cause undesired operation.

Service and Repair

If your system malfunctions, you should attempt to correct or isolate the trouble before concluding that the equipment needs repair. Make sure you have followed the setup procedure and operating instructions. Check the interconnecting cables and then go through the **Troubleshooting** section in this manual.

We strongly recommend that you **do not** try to repair the equipment yourself and **do not** have the local repair shop attempt anything other than the simplest repair. If the repair is more complicated than a broken wire or loose connection, send the unit to the factory for repair and service. Don't attempt to adjust any controls inside the units. Once set at the factory, the various controls and trimmers do not drift with age or vibration and never require readjustment. **There are no adjustments inside that will make a malfunctioning unit start working.**

LECTROSONICS' Service Department is equipped and staffed to quickly repair your equipment. In warranty repairs are made at no charge in accordance with the terms of the warranty. Out-of-warranty repairs are charged at a modest flat rate plus parts and shipping. Since it takes almost as much time and effort to determine what is wrong as it does to make the repair, there is a charge for an exact quotation. We will be happy to quote approximate charges by phone for out-of-warranty repairs.

Returning Units for Repair

For timely service, please follow the steps below:

- A.** DO NOT return equipment to the factory for repair without first contacting us by email or by phone. We need to know the nature of the problem, the model number and the serial number of the equipment. We also need a phone number where you can be reached 8 A.M. to 4 P.M. (U.S. Mountain Standard Time).
- B.** After receiving your request, we will issue you a return authorization number (R.A.). This number will help speed your repair through our receiving and repair departments. The return authorization number must be clearly shown on the **outside** of the shipping container.
- C.** Pack the equipment carefully and ship to us, shipping costs prepaid. If necessary, we can provide you with the proper packing materials. UPS is usually the best way to ship the units. Heavy units should be "double-boxed" for safe transport.
- D.** We also strongly recommend that you insure the equipment, since we cannot be responsible for loss of or damage to equipment that you ship. Of course, we insure the equipment when we ship it back to you.

Lectrosonics USA:

Mailing address:

Lectrosonics, Inc.
PO Box 15900
Rio Rancho, NM 87174
USA

Shipping address:

Lectrosonics, Inc.
561 Laser Rd., Suite 102
Rio Rancho, NM 87124
USA

Telephone:

(505) 892-4501
(800) 821-1121 Toll-free
(505) 892-6243 Fax

Web:

www.lectrosonics.com

E-mail:

sales@lectrosonics.com

Lectrosonics Canada:

Mailing Address:

720 Spadina Avenue,
Suite 600
Toronto, Ontario M5S 2T9

Telephone:

(416) 596-2202
(877) 753-2876 Toll-free
(877-7LECTRO)
(416) 596-6648 Fax

E-mail:

Sales: colinb@lectrosonics.com
Service: joeb@lectrosonics.com

LIMITED ONE YEAR WARRANTY

The equipment is warranted for one year from date of purchase against defects in materials or workmanship provided it was purchased from an authorized dealer. This warranty does not cover equipment which has been abused or damaged by careless handling or shipping. This warranty does not apply to used or demonstrator equipment.

Should any defect develop, Lectrosonics, Inc. will, at our option, repair or replace any defective parts without charge for either parts or labor. If Lectrosonics, Inc. cannot correct the defect in your equipment, it will be replaced at no charge with a similar new item. Lectrosonics, Inc. will pay for the cost of returning your equipment to you.

This warranty applies only to items returned to Lectrosonics, Inc. or an authorized dealer, shipping costs prepaid, within one year from the date of purchase.

This Limited Warranty is governed by the laws of the State of New Mexico. It states the entire liability of Lectrosonics Inc. and the entire remedy of the purchaser for any breach of warranty as outlined above. NEITHER LECTROSONICS, INC. NOR ANYONE INVOLVED IN THE PRODUCTION OR DELIVERY OF THE EQUIPMENT SHALL BE LIABLE FOR ANY INDIRECT, SPECIAL, PUNITIVE, CONSEQUENTIAL, OR INCIDENTAL DAMAGES ARISING OUT OF THE USE OR INABILITY TO USE THIS EQUIPMENT EVEN IF LECTROSONICS, INC. HAS BEEN ADVISED OF THE POSSIBILITY OF SUCH DAMAGES. IN NO EVENT SHALL THE LIABILITY OF LECTROSONICS, INC. EXCEED THE PURCHASE PRICE OF ANY DEFECTIVE EQUIPMENT.

This warranty gives you specific legal rights. You may have additional legal rights which vary from state to state.

