



FCC TEST REPORT

REPORT NO.: RF130710C03
MODEL NO.: UZB
FCC ID: D87-SG-UZB3503
RECEIVED: Jul. 15, 2013
TESTED: Jul. 30 ~ Jul. 31, 2013
ISSUED: Jul. 31, 2013

APPLICANT : Sigma Designs, Inc

ADDRESS : 1778 McCarthy Blvd., Milpitas, California, United States, 95035

ISSUED BY: Bureau Veritas Consumer Products Services (H.K.) Ltd., Taoyuan Branch

LAB ADDRESS: No. 47, 14th Ling, Chia Pau Vil., Lin Kou Dist., New Taipei City, Taiwan (R.O.C.)

TEST LOCATION: No. 19, Hwa Ya 2nd Rd, Wen Hwa Tsuen, Kwei Shan Hsiang, Taoyuan Hsien 333, Taiwan, R.O.C.

This report should not be used by the client to claim product certification, approval, or endorsement by TAF or any government agencies.



This report is for your exclusive use. Any copying or replication of this report to or for any other person or entity, or use of our name or trademark, is permitted only with our prior written permission. This report sets forth our findings solely with respect to the test samples identified herein. The results set forth in this report are not indicative or representative of the quality or characteristics of the lot from which a test sample was taken or any similar or identical product unless specifically and expressly noted. Our report includes all of the tests requested by you and the results thereof based upon the information that you provided to us. You have 60 days from date of issuance of this report to notify us of any material error or omission caused by our negligence, provided, however, that such notice shall be in writing and shall specifically address the issue you wish to raise. A failure to raise such issue within the prescribed time shall constitute your unqualified acceptance of the completeness of this report, the tests conducted and the correctness of the report contents. Unless specific mention, the uncertainty of measurement has been explicitly taken into account to declare the compliance or non-compliance to the specification.

Table of Contents

RELEASE CONTROL RECORD	3
1. CERTIFICATION	4
2. SUMMARY OF TEST RESULTS	5
2.1 MEASUREMENT UNCERTAINTY	5
3. GENERAL INFORMATION	6
3.1 GENERAL DESCRIPTION OF EUT	6
3.2 DESCRIPTION OF TEST MODES	6
3.2.1 TEST MODE APPLICABILITY AND TESTED CHANNEL DETAIL	7
3.3 DESCRIPTION OF SUPPORT UNITS	8
3.3.1 CONFIGURATION OF SYSTEM UNDER TEST	8
3.4 GENERAL DESCRIPTION OF APPLIED STANDARDS	9
4. TEST TYPES AND RESULTS	10
4.1 RADIATED EMISSION MEASUREMENT	10
4.1.1 LIMITS OF RADIATED EMISSION MEASUREMENT	10
4.1.2 TEST INSTRUMENTS	11
4.1.3 TEST PROCEDURES	12
4.1.4 DEVIATION FROM TEST STANDARD	12
4.1.5 TEST SETUP	13
4.1.6 EUT OPERATING CONDITIONS	13
4.1.7 TEST RESULTS	14
4.2 CONDUCTED EMISSION MEASUREMENT	26
4.2.1 LIMITS OF CONDUCTED EMISSION MEASUREMENT	26
4.2.2 TEST INSTRUMENTS	26
4.2.3 TEST PROCEDURES	27
4.2.4 DEVIATION FROM TEST STANDARD	27
4.2.5 TEST SETUP	28
4.2.6 EUT OPERATING CONDITIONS	28
4.2.7 TEST RESULTS	29
4.3 BAND EDGE MEASUREMENT	35
4.3.1 LIMITS OF BAND EDGE MEASUREMENT	35
4.3.2 TEST INSTRUMENTS	36
4.3.3 TEST PROCEDURES	37
4.3.4 DEVIATION FROM TEST STANDARD	37
4.3.5 TEST SETUP	38
4.3.6 EUT OPERATING CONDITIONS	38
4.3.7 TEST RESULTS	39
5. PHOTOGRAPHS OF THE TEST CONFIGURATION	45
6. INFORMATION ON THE TESTING LABORATORIES	46
7. APPENDIX A - MODIFICATIONS RECORDERS FOR ENGINEERING CHANGES TO THE EUT BY THE LAB	47



A D T

RELEASE CONTROL RECORD

ISSUE NO.	REASON FOR CHANGE	DATE ISSUED
RF130710C03	Original release	Jul. 31, 2013



1. CERTIFICATION

PRODUCT: Z-Wave USB Adapter

MODEL NO.: UZB

BRAND: Sigma Designs

APPLICANT: Sigma Designs, Inc

TESTED: Jul. 30 ~ Jul. 31, 2013

TEST SAMPLE: ENGINEERING SAMPLE

STANDARDS: FCC Part 15, Subpart C (Section 15.249)

ANSI C63.10-2009

The above equipment (model: UZB) have been tested by **Bureau Veritas Consumer Products Services (H.K.) Ltd., Taoyuan Branch**, and found compliance with the requirement of the above standards. The test record, data evaluation & Equipment Under Test (EUT) configurations represented herein are true and accurate accounts of the measurements of the sample's EMC characteristics under the conditions specified in this report.

PREPARED BY :  , **DATE:** Jul. 31, 2013
Pettie Chen / Senior Specialist

APPROVED BY :  , **DATE:** Jul. 31, 2013
Ken Liu / Senior Manager



2. SUMMARY OF TEST RESULTS

The EUT has been tested according to the following specifications:

APPLIED STANDARD: FCC Part 15, Subpart C (Section 15.249)			
STANDARD PARAGRAPH	TEST TYPE	RESULT	REMARK
15.207	Conducted Emission Test	PASS	Meet the requirement of limit. Minimum passing margin is -6.23dB at 0.51210MHz.
15.209 15.249	Radiated Emission Test Band Edge Measurement	PASS	Meet the requirement of limit. Minimum passing margin is -1.4dB at 908.40, 916.00MHz

2.1 MEASUREMENT UNCERTAINTY

Where relevant, the following measurement uncertainty levels have been estimated for tests performed on the EUT as specified in CISPR 16-4-2:

MEASUREMENT	FREQUENCY	UNCERTAINTY
Conducted emissions	9kHz~30MHz	2.44 dB
Radiated emissions	30MHz ~ 200MHz	2.93 dB
	200MHz ~1000MHz	2.95 dB
	1GHz ~ 18GHz	2.26 dB
	18GHz ~ 40GHz	1.94 dB

This uncertainty represents an expanded uncertainty expressed at approximately the 95% confidence level using a coverage factor of k=2.

3. GENERAL INFORMATION

3.1 GENERAL DESCRIPTION OF EUT

EUT	Z-Wave USB Adapter
MODEL NO.	UZH
POWER SUPPLY	5Vdc
MODULATION TYPE	2FSK (9.6kbps) / 2GFSK (40kbps, 100kbps)
DATA RATE	9.6kbps, 40kbps, 100kbps
OPERATING FREQUENCY	908.42MHz, 908.4MHz, 916MHz
NUMBER OF CHANNEL	3
ANTENNA TYPE	Helix antenna with 0.2dBi gain
DATA CABLE	NA
I/O PORT	Refer to User's Manual
ACCESSORY DEVICES	NA

NOTE:

The above EUT information is declared by the manufacturer and for more detailed features description, please refer to the manufacturer's specifications or User's Manual.

3.2 DESCRIPTION OF TEST MODES

3 channels are provided to this EUT.

CHANNEL	FREQ. (MHz)	DATA RATE
1	908.42	9.6kbps
2	908.40	40kbps
3	916.00	100kbps

3.2.1 TEST MODE APPLICABILITY AND TESTED CHANNEL DETAIL

EUT CONFIGURE MODE	APPLICABLE TO			DESCRIPTION
	RE \geq 1G	RE $<$ 1G	PLC	
-	√	√	√	

Where **RE $<$ 1G**: Radiated Emission below 1GHz **RE \geq 1G**: Radiated Emission above 1GHz
PLC: Power Line Conducted Emission

NOTE: The EUT had been pre-tested on the positioned of each 3 axis. The worst case was found when positioned on **X-plane**

RADIATED EMISSION TEST (ABOVE 1 GHz):

- Pre-Scan has been conducted to determine the worst-case mode from all possible combinations between available modulations and antenna ports (if EUT with antenna diversity architecture).
- Following channel(s) was (were) selected for the final test as listed below.

TESTED CHANNEL	OPERATING FREQUENCY	MODULATION TYPE
1	908.42MHz	2FSK
2	908.40MHz	2GFSK
3	916.00MHz	2GFSK

RADIATED EMISSION TEST (BELOW 1 GHz):

- Pre-Scan has been conducted to determine the worst-case mode from all possible combinations between available modulations and antenna ports (if EUT with antenna diversity architecture).
- Following channel(s) was (were) selected for the final test as listed below.

TESTED CHANNEL	OPERATING FREQUENCY	MODULATION TYPE
1	908.42MHz	2FSK
2	908.40MHz	2GFSK
3	916.00MHz	2GFSK

POWER LINE CONDUCTED EMISSION TEST:

- Pre-Scan has been conducted to determine the worst-case mode from all possible combinations between available modulations and antenna ports (if EUT with antenna diversity architecture).
- Following channel(s) was (were) selected for the final test as listed below.

TESTED CHANNEL	OPERATING FREQUENCY	MODULATION TYPE
1	908.42MHz	2FSK
2	908.40MHz	2GFSK
3	916.00MHz	2GFSK

TEST CONDITION:

APPLICABLE TO	ENVIRONMENTAL CONDITIONS	INPUT POWER (SYSTEM)	TESTED BY
RE≥1G	26deg. C, 69%RH	120Vac, 60Hz	Brad Tung
RE<1G	26deg. C, 69%RH	120Vac, 60Hz	Brad Tung
PLC	24deg. C, 64%RH	120Vac, 60Hz	Match Tsui

3.3 DESCRIPTION OF SUPPORT UNITS

The EUT has been tested as an independent unit together with other necessary accessories or support units. The following support units or accessories were used to form a representative test configuration during the tests.

NO.	PRODUCT	BRAND	MODEL NO.	SERIAL NO.	FCC ID
1	Notebook	DELL	D531	CN-0XM006-4864 3-81U-2610	QDS-BRCM1020

NO.	SIGNAL CABLE DESCRIPTION OF THE ABOVE SUPPORT UNITS
1	NA

NOTE: All power cords of the above support units are non shielded (1.8m).

3.3.1 CONFIGURATION OF SYSTEM UNDER TEST

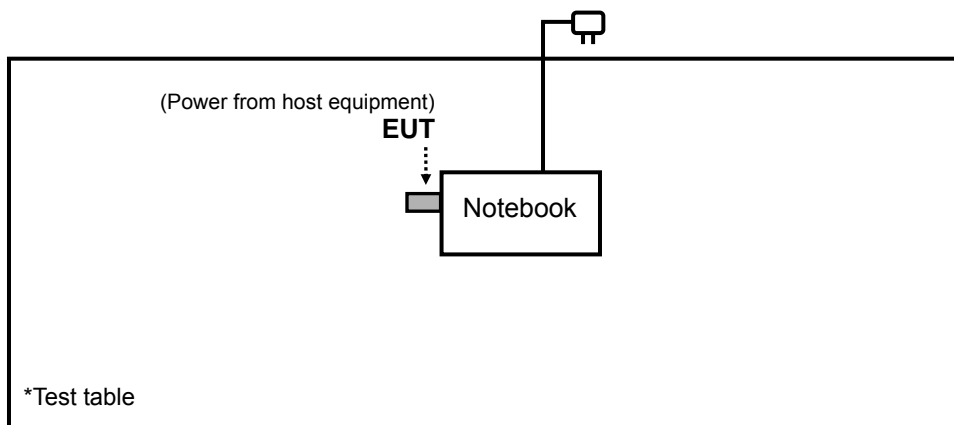



3.4 GENERAL DESCRIPTION OF APPLIED STANDARDS

The EUT is a RF Product. According to the specifications of the manufacturer, it must comply with the requirements of the following standards:

FCC Part 15, Subpart C (Section 15.249)

ANSI C63.10-2009

All test items have been performed and recorded as per the above standards.

NOTE: The EUT is also considered as a kind of computer peripheral, because the connection to computer is necessary for typical use. It has been verified to comply with the requirements of FCC Part 15, Subpart B, Class B (DoC). The test report has been issued separately.

4. TEST TYPES AND RESULTS

4.1 RADIATED EMISSION MEASUREMENT

4.1.1 LIMITS OF RADIATED EMISSION MEASUREMENT

The field strength of emissions from intentional radiators operated within these frequency bands shall comply with the following

Fundamental Frequency	Field Strength of Fundamental (millivolts/meter)	Field Strength of Harmonics (microvolts/meter)
902 ~ 928 MHz	50	500
2400 ~ 2483.5 MHz	50	500
5725 ~ 5875 MHz	50	500
24 ~ 24.25 GHz	250	2500

Emissions radiated outside of the specified frequency bands, except for harmonics, shall be attenuated by at least 50 dB below the level of the fundamental or to the general radiated emission limits as below table, whichever is the lesser attenuation

Frequencies (MHz)	Field strength (microvolts/meter)	Measurement distance (meters)
0.009 ~ 0.490	2400/F(kHz)	300
0.490 ~ 1.705	24000/F(kHz)	30
1.705 ~ 30.0	30	30
30 ~ 88	100	3
88 ~ 216	150	3
216 ~ 960	200	3
Above 960	500	3

NOTE:

1. The lower limit shall apply at the transition frequencies.
2. Emission level (dBuV/m) = 20 log Emission level (uV/m).
3. For frequencies above 1000MHz, the field strength limits are based on average detector, however, the peak field strength of any emission shall not exceed the maximum permitted average limits, specified above by more than 20dB under any condition of modulation.



4.1.2 TEST INSTRUMENTS

DESCRIPTION & MANUFACTURER	MODEL NO.	SERIAL NO.	DATE OF CALIBRATION	DUE DATE OF CALIBRATION
Test Receiver ROHDE & SCHWARZ	ESCS30	100289	Nov. 16, 2012	Nov. 15, 2013
Spectrum Analyzer ROHDE & SCHWARZ	FSP40	100269	Jan. 28, 2013	Jan. 27, 2014
BILOG Antenna SCHWARZBECK	VULB9168	9168-156	Mar. 22, 2013	Mar. 21, 2014
HORN Antenna SCHWARZBECK	BBHA 9120 D	9120D-209	Sep. 03, 2012	Sep. 02, 2013
HORN Antenna SCHWARZBECK	BBHA 9170	148	Jul. 15, 2013	Jul. 14, 2014
Loop Antenna	HFH2-Z2	100070	Jan. 31, 2012	Jan. 30, 2014
Preamplifier Agilent	8449B	3008A01911	Oct. 25, 2012	Oct. 24, 2013
Preamplifier Agilent	8447D	2944A10638	Oct. 25, 2012	Oct. 24, 2013
RF signal cable HUBER+SUHNNER	SUCOFLEX 104	295013/4 283403/4	Aug. 28, 2012	Aug. 27, 2013
RF signal cable Worken	8D-FB	Cable-HYCH9-01	Aug. 11, 2012	Aug. 10, 2013
Software BV ADT	ADT_Radiated_ V7.6.15.9.4	NA	NA	NA
Antenna Tower EMCO	2070/2080	512.835.4684	NA	NA
Turn Table EMCO	2087-2.03	NA	NA	NA
Antenna Tower & Turn Table Controller EMCO	2090	NA	NA	NA
Turn Table BV ADT	TT100.	TT93021704	NA	NA
Turn Table Controller BV ADT	SC100.	SC93021704	NA	NA

- NOTE:**
1. The calibration interval of the above test instruments is 12 months and the calibrations are traceable to NML/ROC and NIST/USA.
 2. The calibration interval of the loop antenna is 24 months and the calibrations are traceable to NML/ROC and NIST/USA.
 3. The test was performed in HwaYa Chamber 9.
 4. The horn antenna and HP preamplifier (model: 8449B) are used only for the measurement of emission frequency above 1GHz if tested.
 5. The FCC Site Registration No. is 215374.
 6. The IC Site Registration No. is IC 7450F-9.

4.1.3 TEST PROCEDURES

- a. The EUT was placed on the top of a rotating table 0.8 meters above the ground at a 3 meter semi-anechoic chamber. The table was rotated 360 degrees to determine the position of the highest radiation.
- b. The EUT was set 3 meters away from the interference-receiving antenna, which was mounted on the top of a variable-height antenna tower.
- c. The antenna is a broadband antenna, and its height is varied from one meter to four meters above the ground to determine the maximum value of the field strength. Both horizontal and vertical polarizations of the antenna are set to make the measurement.
- d. For each suspected emission, the EUT was arranged to its worst case and then the antenna was tuned to heights from 1 meter to 4 meters and the rotatable table was turned from 0 degrees to 360 degrees to find the maximum reading.
- e. The test-receiver system was set to Peak Detect Function and Specified Bandwidth with Maximum Hold Mode.
- f. If the emission level of the EUT in peak mode was lower than the limit specified, then testing could be stopped and the peak values of the EUT would be reported. Otherwise the emissions would be re-tested one by one using peak, quasi-peak or average method as specified and then reported in a data sheet.

NOTE:

1. The resolution bandwidth and video bandwidth of test receiver/spectrum analyzer is 120kHz for Quasi-peak detection at frequency below 1GHz.
2. The resolution bandwidth of test receiver/spectrum analyzer is 1MHz and video bandwidth is 3MHz for Peak detection at frequency above 1GHz.
3. The resolution bandwidth of test receiver/spectrum analyzer is 1MHz and the video bandwidth is 1kHz(Duty cycle < 98%) or 10Hz(Duty cycle > 98%) for Average detection (AV) at frequency above 1GHz.
4. All modes of operation were investigated and the worst-case emissions are reported.

4.1.4 DEVIATION FROM TEST STANDARD

No deviation.

4.1.5 TEST SETUP

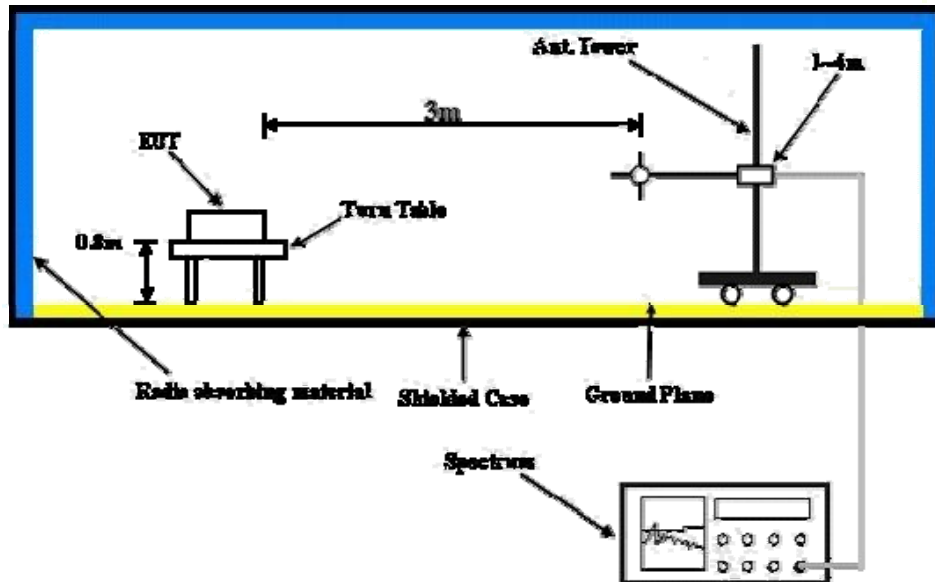

For the actual test configuration, please refer to the attached file (Test Setup Photo).

4.1.6 EUT OPERATING CONDITIONS

- a. Plugged EUT into notebook and placed them on the testing table.
- b. The notebook ran test program (provided by manufacturer) to enable EUT under transmission condition continuously at specific channel frequency.



4.1.7 TEST RESULTS

EUT TEST CONDITION		MEASUREMENT DETAIL	
CHANNEL	Channel 1 (908.42MHz)	FREQUENCY RANGE	Below 1000MHz
INPUT POWER	120Vac, 60 Hz	DETECTOR FUNCTION	Peak (PK) Average (AV)
ENVIRONMENTAL CONDITIONS	26deg. C, 69%RH	TESTED BY	Brad Tung

ANTENNA POLARITY & TEST DISTANCE: HORIZONTAL AT 3 M								
NO.	FREQ. (MHz)	EMISSION LEVEL (dBuV/m)	LIMIT (dBuV/m)	MARGIN (dB)	ANTENNA HEIGHT (m)	TABLE ANGLE (Degree)	RAW VALUE (dBuV)	CORRECTION FACTOR (dB/m)
1	*908.42	92.8 PK	114.0	-21.2	1.57 H	225	65.90	26.90
2	*908.42	92.4 AV	94.0	-1.6	1.57 H	225	65.50	26.90
ANTENNA POLARITY & TEST DISTANCE: VERTICAL AT 3 M								
NO.	FREQ. (MHz)	EMISSION LEVEL (dBuV/m)	LIMIT (dBuV/m)	MARGIN (dB)	ANTENNA HEIGHT (m)	TABLE ANGLE (Degree)	RAW VALUE (dBuV)	CORRECTION FACTOR (dB/m)
1	*908.42	91.6 PK	114.0	-22.4	1.49 V	211	64.70	26.90
2	*908.42	91.3 AV	94.0	-2.7	1.49 V	211	64.40	26.90

- REMARKS:**
1. Emission level (dBuV/m) = Raw Value (dBuV) + Correction Factor (dB/m).
 2. Correction Factor (dB/m) = Antenna Factor (dB/m) + Cable Factor (dB) – Pre-Amplifier Factor (dB).
 3. The other emission levels were very low against the limit.
 4. Margin value = Emission level – Limit value.
 5. “ * “ : Fundamental frequency



A D T

EUT TEST CONDITION		MEASUREMENT DETAIL	
CHANNEL	Channel 2 (908.40MHz)	FREQUENCY RANGE	Below 1000MHz
INPUT POWER	120Vac, 60 Hz	DETECTOR FUNCTION	Peak (PK) Average (AV)
ENVIRONMENTAL CONDITIONS	26deg. C, 69%RH	TESTED BY	Brad Tung

ANTENNA POLARITY & TEST DISTANCE: HORIZONTAL AT 3 M								
NO.	FREQ. (MHz)	EMISSION LEVEL (dBuV/m)	LIMIT (dBuV/m)	MARGIN (dB)	ANTENNA HEIGHT (m)	TABLE ANGLE (Degree)	RAW VALUE (dBuV)	CORRECTION FACTOR (dB/m)
1	*908.40	92.9 PK	114.0	-21.1	1.50 H	96	66.00	26.90
2	*908.40	92.6 AV	94.0	-1.4	1.50 H	96	65.70	26.90
ANTENNA POLARITY & TEST DISTANCE: VERTICAL AT 3 M								
NO.	FREQ. (MHz)	EMISSION LEVEL (dBuV/m)	LIMIT (dBuV/m)	MARGIN (dB)	ANTENNA HEIGHT (m)	TABLE ANGLE (Degree)	RAW VALUE (dBuV)	CORRECTION FACTOR (dB/m)
1	*908.40	91.8 PK	114.0	-22.2	1.53 V	205	64.90	26.90
2	*908.40	91.5 AV	94.0	-2.5	1.53 V	205	64.60	26.90

- REMARKS:**
1. Emission level (dBuV/m) = Raw Value (dBuV) + Correction Factor (dB/m).
 2. Correction Factor (dB/m) = Antenna Factor (dB/m) + Cable Factor (dB) – Pre-Amplifier Factor (dB).
 3. The other emission levels were very low against the limit.
 4. Margin value = Emission level – Limit value.
 5. “ * ” : Fundamental frequency



A D T

EUT TEST CONDITION		MEASUREMENT DETAIL	
CHANNEL	Channel 3 (916.00MHz)	FREQUENCY RANGE	Below 1000MHz
INPUT POWER	120Vac, 60 Hz	DETECTOR FUNCTION	Peak (PK) Average (AV)
ENVIRONMENTAL CONDITIONS	26deg. C, 69%RH	TESTED BY	Brad Tung

ANTENNA POLARITY & TEST DISTANCE: HORIZONTAL AT 3 M								
NO.	FREQ. (MHz)	EMISSION LEVEL (dBuV/m)	LIMIT (dBuV/m)	MARGIN (dB)	ANTENNA HEIGHT (m)	TABLE ANGLE (Degree)	RAW VALUE (dBuV)	CORRECTION FACTOR (dB/m)
1	*916.00	93.8 PK	114.0	-20.2	1.40 H	123	66.80	27.00
2	*916.00	92.6 AV	94.0	-1.4	1.40 H	123	65.60	27.00
ANTENNA POLARITY & TEST DISTANCE: VERTICAL AT 3 M								
NO.	FREQ. (MHz)	EMISSION LEVEL (dBuV/m)	LIMIT (dBuV/m)	MARGIN (dB)	ANTENNA HEIGHT (m)	TABLE ANGLE (Degree)	RAW VALUE (dBuV)	CORRECTION FACTOR (dB/m)
1	*916.00	92.3 PK	114.0	-21.7	1.50 V	200	65.30	27.00
2	*916.00	91.4 AV	94.0	-2.6	1.50 V	200	64.40	27.00

- REMARKS:**
1. Emission level (dBuV/m) = Raw Value (dBuV) + Correction Factor (dB/m).
 2. Correction Factor (dB/m) = Antenna Factor (dB/m) + Cable Factor (dB) – Pre-Amplifier Factor (dB).
 3. The other emission levels were very low against the limit.
 4. Margin value = Emission level – Limit value.
 5. “ * ” : Fundamental frequency



ABOVE 1GHz DATA

EUT TEST CONDITION		MEASUREMENT DETAIL	
CHANNEL	Channel 1 (908.42MHz)	FREQUENCY RANGE	1 ~ 25GHz
INPUT POWER	120Vac, 60Hz	DETECTOR FUNCTION	Peak (PK) Average (AV)
ENVIRONMENTAL CONDITIONS	26deg. C, 69%RH	TESTED BY	Brad Tung

ANTENNA POLARITY & TEST DISTANCE: HORIZONTAL AT 3 M								
NO.	FREQ. (MHz)	EMISSION LEVEL (dBuV/m)	LIMIT (dBuV/m)	MARGIN (dB)	ANTENNA HEIGHT (m)	TABLE ANGLE (Degree)	RAW VALUE (dBuV)	CORRECTION FACTOR (dB/m)
1	1816.84	41.9 PK	74.0	-32.1	1.25 H	33	46.80	-4.90
2	1816.84	29.0 AV	54.0	-25.0	1.25 H	33	33.90	-4.90
3	2725.26	46.9 PK	74.0	-27.1	1.50 H	300	47.90	-1.00
4	2725.26	41.8 AV	54.0	-12.2	1.50 H	300	42.80	-1.00
5	3633.68	46.0 PK	74.0	-28.0	1.24 H	60	43.80	2.20
6	3633.68	32.0 AV	54.0	-22.0	1.24 H	60	29.80	2.20
7	4542.10	48.2 PK	74.0	-25.8	1.60 H	88	44.20	4.00
8	4542.10	37.0 AV	54.0	-17.0	1.60 H	88	33.00	4.00
9	5450.52	50.0 PK	74.0	-24.0	1.32 H	256	43.80	6.20
10	5450.52	35.2 AV	54.0	-18.8	1.32 H	256	29.00	6.20
11	6358.94	50.3 PK	74.0	-23.7	1.15 H	160	43.60	6.70
12	6358.94	37.2 AV	54.0	-16.8	1.15 H	160	30.50	6.70
13	7267.36	54.1 PK	74.0	-19.9	1.55 H	10	45.10	9.00
14	7267.36	41.0 AV	54.0	-13.0	1.55 H	10	32.00	9.00
15	8175.78	56.1 PK	74.0	-17.9	1.00 H	26	45.70	10.40
16	8175.78	42.9 AV	54.0	-11.1	1.00 H	26	32.50	10.40
17	9084.20	56.1 PK	74.0	-17.9	1.03 H	47	44.80	11.30
18	9084.20	42.3 AV	54.0	-11.7	1.03 H	47	31.00	11.30
19	9992.62	58.9 PK	74.0	-15.1	1.25 H	300	47.00	11.90
20	9992.62	45.8 AV	54.0	-8.2	1.25 H	300	33.90	11.90

- REMARKS:**
1. Emission level (dBuV/m) = Raw Value (dBuV) + Correction Factor (dB/m).
 2. Correction Factor (dB/m) = Antenna Factor (dB/m) + Cable Factor (dB)
– Pre-Amplifier Factor (dB).
 3. The other emission levels were very low against the limit.
 4. Margin value = Emission level – Limit value.



A D T

EUT TEST CONDITION		MEASUREMENT DETAIL	
CHANNEL	Channel 1 (908.42MHz)	FREQUENCY RANGE	1 ~ 25GHz
INPUT POWER	120Vac, 60Hz	DETECTOR FUNCTION	Peak (PK) Average (AV)
ENVIRONMENTAL CONDITIONS	26deg. C, 69%RH	TESTED BY	Brad Tung

ANTENNA POLARITY & TEST DISTANCE: VERTICAL AT 3 M								
NO.	FREQ. (MHz)	EMISSION LEVEL (dBuV/m)	LIMIT (dBuV/m)	MARGIN (dB)	ANTENNA HEIGHT (m)	TABLE ANGLE (Degree)	RAW VALUE (dBuV)	CORRECTION FACTOR (dB/m)
1	1816.84	39.0 PK	74.0	-35.0	1.30 V	25	43.90	-4.90
2	1816.84	31.2 AV	54.0	-22.8	1.30 V	25	36.10	-4.90
3	2725.26	45.6 PK	74.0	-28.4	1.10 V	50	46.60	-1.00
4	2725.26	37.7 AV	54.0	-16.3	1.10 V	50	38.70	-1.00
5	3633.68	46.2 PK	74.0	-27.8	1.00 V	75	44.00	2.20
6	3633.68	33.0 AV	54.0	-21.0	1.00 V	75	30.80	2.20
7	4542.10	49.4 PK	74.0	-24.6	1.43 V	3	45.40	4.00
8	4542.10	41.0 AV	54.0	-13.0	1.43 V	3	37.00	4.00
9	5450.52	49.0 PK	74.0	-25.0	1.03 V	70	42.80	6.20
10	5450.52	35.0 AV	54.0	-19.0	1.03 V	70	28.80	6.20
11	6358.94	51.0 PK	74.0	-23.0	1.45 V	300	44.30	6.70
12	6358.94	37.2 AV	54.0	-16.8	1.45 V	300	30.50	6.70
13	7267.36	54.0 PK	74.0	-20.0	1.12 V	60	45.00	9.00
14	7267.36	39.5 AV	54.0	-14.5	1.12 V	60	30.50	9.00
15	8175.78	55.8 PK	74.0	-18.2	1.00 V	6	45.40	10.40
16	8175.78	45.2 AV	54.0	-8.8	1.00 V	6	34.80	10.40
17	9084.20	57.0 PK	74.0	-17.0	1.04 V	70	45.70	11.30
18	9084.20	42.2 AV	54.0	-11.8	1.04 V	70	30.90	11.30
19	9987.62	58.0 PK	74.0	-16.0	1.26 V	286	46.10	11.90
20	9987.62	44.7 AV	54.0	-9.3	1.26 V	286	32.80	11.90

- REMARKS:**
1. Emission level (dBuV/m) = Raw Value (dBuV) + Correction Factor (dB/m).
 2. Correction Factor (dB/m) = Antenna Factor (dB/m) + Cable Factor (dB)
– Pre-Amplifier Factor (dB).
 3. The other emission levels were very low against the limit.
 4. Margin value = Emission level – Limit value.



A D T

EUT TEST CONDITION		MEASUREMENT DETAIL	
CHANNEL	Channel 2 (908.40MHz)	FREQUENCY RANGE	1 ~ 25GHz
INPUT POWER	120Vac, 60Hz	DETECTOR FUNCTION	Peak (PK) Average (AV)
ENVIRONMENTAL CONDITIONS	26deg. C, 69%RH	TESTED BY	Brad Tung

ANTENNA POLARITY & TEST DISTANCE: HORIZONTAL AT 3 M								
NO.	FREQ. (MHz)	EMISSION LEVEL (dBuV/m)	LIMIT (dBuV/m)	MARGIN (dB)	ANTENNA HEIGHT (m)	TABLE ANGLE (Degree)	RAW VALUE (dBuV)	CORRECTION FACTOR (dB/m)
1	1816.80	41.9 PK	74.0	-32.1	1.34 H	30	46.80	-4.90
2	1816.80	28.8 AV	54.0	-25.2	1.34 H	30	33.70	-4.90
3	2725.20	46.9 PK	74.0	-27.1	1.44 H	12	47.90	-1.00
4	2725.20	41.2 AV	54.0	-12.8	1.44 H	12	42.20	-1.00
5	3633.60	46.0 PK	74.0	-28.0	1.00 H	200	43.80	2.20
6	3633.60	32.5 AV	54.0	-21.5	1.00 H	200	30.30	2.20
7	4542.00	48.0 PK	74.0	-26.0	1.46 H	288	44.00	4.00
8	4542.00	35.2 AV	54.0	-18.8	1.46 H	288	31.20	4.00
9	5450.40	49.8 PK	74.0	-24.2	1.32 H	63	43.60	6.20
10	5450.40	36.3 AV	54.0	-17.7	1.32 H	63	30.10	6.20
11	6358.80	50.8 PK	74.0	-23.2	1.00 H	8	44.10	6.70
12	6358.80	36.9 AV	54.0	-17.1	1.00 H	8	30.20	6.70
13	7267.20	53.8 PK	74.0	-20.2	1.25 H	259	44.80	9.00
14	7267.20	40.6 AV	54.0	-13.4	1.25 H	259	31.60	9.00
15	8175.60	54.9 PK	74.0	-19.1	1.31 H	75	44.50	10.40
16	8175.60	42.5 AV	54.0	-11.5	1.31 H	75	32.10	10.40
17	9084.00	56.3 PK	74.0	-17.7	1.33 H	2	45.00	11.30
18	9084.00	42.3 AV	54.0	-11.7	1.33 H	2	31.00	11.30
19	9992.40	58.5 PK	74.0	-15.5	1.00 H	74	46.60	11.90
20	9992.40	45.0 AV	54.0	-9.0	1.00 H	74	33.10	11.90

- REMARKS:**
1. Emission level (dBuV/m) = Raw Value (dBuV) + Correction Factor (dB/m).
 2. Correction Factor (dB/m) = Antenna Factor (dB/m) + Cable Factor (dB)
– Pre-Amplifier Factor (dB).
 3. The other emission levels were very low against the limit.
 4. Margin value = Emission level – Limit value.



EUT TEST CONDITION		MEASUREMENT DETAIL	
CHANNEL	Channel 2 (908.40MHz)	FREQUENCY RANGE	1 ~ 25GHz
INPUT POWER	120Vac, 60Hz	DETECTOR FUNCTION	Peak (PK) Average (AV)
ENVIRONMENTAL CONDITIONS	26deg. C, 69%RH	TESTED BY	Brad Tung

ANTENNA POLARITY & TEST DISTANCE: VERTICAL AT 3 M								
NO.	FREQ. (MHz)	EMISSION LEVEL (dBuV/m)	LIMIT (dBuV/m)	MARGIN (dB)	ANTENNA HEIGHT (m)	TABLE ANGLE (Degree)	RAW VALUE (dBuV)	CORRECTION FACTOR (dB/m)
1	1816.80	43.0 PK	74.0	-31.0	1.34 V	20	47.90	-4.90
2	1816.80	28.2 AV	54.0	-25.8	1.34 V	20	33.10	-4.90
3	2725.20	45.2 PK	74.0	-28.8	1.24 V	300	46.20	-1.00
4	2725.20	35.3 AV	54.0	-18.7	1.24 V	300	36.30	-1.00
5	3633.60	46.2 PK	74.0	-27.8	1.52 V	60	44.00	2.20
6	3633.60	33.1 AV	54.0	-20.9	1.52 V	60	30.90	2.20
7	4542.00	49.1 PK	74.0	-24.9	1.00 V	3	45.10	4.00
8	4542.00	41.0 AV	54.0	-13.0	1.00 V	3	37.00	4.00
9	5450.40	49.0 PK	74.0	-25.0	1.72 V	63	42.80	6.20
10	5450.40	36.2 AV	54.0	-17.8	1.72 V	63	30.00	6.20
11	6358.80	51.0 PK	74.0	-23.0	1.15 V	46	44.30	6.70
12	6358.80	38.1 AV	54.0	-15.9	1.15 V	46	31.40	6.70
13	7267.20	54.9 PK	74.0	-19.1	1.53 V	200	45.90	9.00
14	7267.20	41.2 AV	54.0	-12.8	1.53 V	200	32.20	9.00
15	8175.60	56.9 PK	74.0	-17.1	1.42 V	9	46.50	10.40
16	8175.60	44.6 AV	54.0	-9.4	1.42 V	9	34.20	10.40
17	9084.00	56.2 PK	74.0	-17.8	1.27 V	10	44.90	11.30
18	9084.00	42.9 AV	54.0	-11.1	1.27 V	10	31.60	11.30
19	9992.40	57.7 PK	74.0	-16.3	1.00 V	244	45.80	11.90
20	9992.40	44.6 AV	54.0	-9.4	1.00 V	244	32.70	11.90

- REMARKS:**
1. Emission level (dBuV/m) = Raw Value (dBuV) + Correction Factor (dB/m).
 2. Correction Factor (dB/m) = Antenna Factor (dB/m) + Cable Factor (dB)
– Pre-Amplifier Factor (dB).
 3. The other emission levels were very low against the limit.
 4. Margin value = Emission level – Limit value.



A D T

EUT TEST CONDITION		MEASUREMENT DETAIL	
CHANNEL	Channel 3 (916.00MHz)	FREQUENCY RANGE	1 ~ 25GHz
INPUT POWER	120Vac, 60Hz	DETECTOR FUNCTION	Peak (PK) Average (AV)
ENVIRONMENTAL CONDITIONS	26deg. C, 69%RH	TESTED BY	Brad Tung

ANTENNA POLARITY & TEST DISTANCE: HORIZONTAL AT 3 M								
NO.	FREQ. (MHz)	EMISSION LEVEL (dBuV/m)	LIMIT (dBuV/m)	MARGIN (dB)	ANTENNA HEIGHT (m)	TABLE ANGLE (Degree)	RAW VALUE (dBuV)	CORRECTION FACTOR (dB/m)
1	1832.00	41.0 PK	74.0	-33.0	1.27 H	80	45.70	-4.70
2	1832.00	28.2 AV	54.0	-25.8	1.27 H	80	32.90	-4.70
3	2748.00	49.6 PK	74.0	-24.4	1.36 H	30	50.70	-1.10
4	2748.00	46.0 AV	54.0	-8.0	1.36 H	30	47.10	-1.10
5	3664.00	45.8 PK	74.0	-28.2	1.13 H	50	43.40	2.40
6	3664.00	32.5 AV	54.0	-21.5	1.13 H	50	30.10	2.40
7	4580.00	48.5 PK	74.0	-25.5	1.35 H	60	44.40	4.10
8	4580.00	38.2 AV	54.0	-15.8	1.35 H	60	34.10	4.10
9	5496.00	51.0 PK	74.0	-23.0	1.54 H	311	44.70	6.30
10	5496.00	36.3 AV	54.0	-17.7	1.54 H	311	30.00	6.30
11	6412.00	51.8 PK	74.0	-22.2	1.12 H	2	45.00	6.80
12	6412.00	38.2 AV	54.0	-15.8	1.12 H	2	31.40	6.80
13	7328.00	55.0 PK	74.0	-19.0	1.44 H	93	45.80	9.20
14	7328.00	40.9 AV	54.0	-13.1	1.44 H	93	31.70	9.20
15	8244.00	55.9 PK	74.0	-18.1	1.82 H	50	45.50	10.40
16	8244.00	41.9 AV	54.0	-12.1	1.82 H	50	31.50	10.40
17	9160.00	56.0 PK	74.0	-18.0	1.40 H	325	44.80	11.20
18	9160.00	42.6 AV	54.0	-11.4	1.40 H	325	31.40	11.20
19	10076.00	58.9 PK	74.0	-15.1	1.25 H	305	47.00	11.90
20	10076.00	45.0 AV	54.0	-9.0	1.25 H	305	33.10	11.90

- REMARKS:**
1. Emission level (dBuV/m) = Raw Value (dBuV) + Correction Factor (dB/m).
 2. Correction Factor (dB/m) = Antenna Factor (dB/m) + Cable Factor (dB)
– Pre-Amplifier Factor (dB).
 3. The other emission levels were very low against the limit.
 4. Margin value = Emission level – Limit value.



A D T

EUT TEST CONDITION		MEASUREMENT DETAIL	
CHANNEL	Channel 3 (916.00MHz)	FREQUENCY RANGE	1 ~ 25GHz
INPUT POWER	120Vac, 60Hz	DETECTOR FUNCTION	Peak (PK) Average (AV)
ENVIRONMENTAL CONDITIONS	26deg. C, 69%RH	TESTED BY	Brad Tung

ANTENNA POLARITY & TEST DISTANCE: VERTICAL AT 3 M								
NO.	FREQ. (MHz)	EMISSION LEVEL (dBuV/m)	LIMIT (dBuV/m)	MARGIN (dB)	ANTENNA HEIGHT (m)	TABLE ANGLE (Degree)	RAW VALUE (dBuV)	CORRECTION FACTOR (dB/m)
1	1832.00	40.2 PK	74.0	-33.8	1.30 V	44	44.90	-4.70
2	1832.00	28.3 AV	54.0	-25.7	1.30 V	44	33.00	-4.70
3	2748.00	48.2 PK	74.0	-25.8	1.06 V	200	49.30	-1.10
4	2748.00	44.0 AV	54.0	-10.0	1.06 V	200	45.10	-1.10
5	3664.00	46.0 PK	74.0	-28.0	1.49 V	183	43.60	2.40
6	3664.00	33.9 AV	54.0	-20.1	1.49 V	183	31.50	2.40
7	4580.00	51.3 PK	74.0	-22.7	1.26 V	325	47.20	4.10
8	4580.00	43.4 AV	54.0	-10.6	1.26 V	325	39.30	4.10
9	5496.00	51.2 PK	74.0	-22.8	1.20 V	80	44.90	6.30
10	5496.00	36.4 AV	54.0	-17.6	1.20 V	80	30.10	6.30
11	6412.00	51.0 PK	74.0	-23.0	1.39 V	6	44.20	6.80
12	6412.00	38.2 AV	54.0	-15.8	1.39 V	6	31.40	6.80
13	7238.00	54.2 PK	74.0	-19.8	1.27 V	169	45.20	9.00
14	7238.00	40.2 AV	54.0	-13.8	1.27 V	169	31.20	9.00
15	8244.00	56.5 PK	74.0	-17.5	1.13 V	105	46.10	10.40
16	8244.00	48.2 AV	54.0	-5.8	1.13 V	105	37.80	10.40
17	9160.00	56.8 PK	74.0	-17.2	1.00 V	0	45.60	11.20
18	9160.00	43.0 AV	54.0	-11.0	1.00 V	0	31.80	11.20
19	10076.00	61.1 PK	74.0	-12.9	1.12 V	5	49.20	11.90
20	10076.00	47.0 AV	54.0	-7.0	1.12 V	5	35.10	11.90

- REMARKS:**
1. Emission level (dBuV/m) = Raw Value (dBuV) + Correction Factor (dB/m).
 2. Correction Factor (dB/m) = Antenna Factor (dB/m) + Cable Factor (dB)
– Pre-Amplifier Factor (dB).
 3. The other emission levels were very low against the limit.
 4. Margin value = Emission level – Limit value.

**BELOW 1GHz WORST-CASE DATA**

EUT TEST CONDITION		MEASUREMENT DETAIL	
CHANNEL	Channel 1 (908.42MHz)	FREQUENCY RANGE	Below 1000MHz
INPUT POWER	120Vac, 60Hz	DETECTOR FUNCTION	Quasi-Peak
ENVIRONMENTAL CONDITIONS	26deg. C, 69%RH	TESTED BY	Brad Tung

ANTENNA POLARITY & TEST DISTANCE: HORIZONTAL AT 3 M								
NO.	FREQ. (MHz)	EMISSION LEVEL (dBuV/m)	LIMIT (dBuV/m)	MARGIN (dB)	ANTENNA HEIGHT (m)	TABLE ANGLE (Degree)	RAW VALUE (dBuV)	CORRECTION FACTOR (dB/m)
1	35.82	29.2 QP	40.0	-10.8	1.50 H	18	44.20	-15.00
2	142.52	33.2 QP	43.5	-10.3	2.00 H	274	47.50	-14.30
3	198.78	37.1 QP	43.5	-6.4	1.25 H	94	53.80	-16.70
4	437.40	38.2 QP	46.0	-7.8	1.00 H	188	47.60	-9.40
5	600.36	34.5 QP	46.0	-11.5	1.25 H	88	40.70	-6.20
6	633.34	33.9 QP	46.0	-12.1	1.00 H	58	39.60	-5.70

ANTENNA POLARITY & TEST DISTANCE: VERTICAL AT 3 M								
NO.	FREQ. (MHz)	EMISSION LEVEL (dBuV/m)	LIMIT (dBuV/m)	MARGIN (dB)	ANTENNA HEIGHT (m)	TABLE ANGLE (Degree)	RAW VALUE (dBuV)	CORRECTION FACTOR (dB/m)
1	35.82	31.3 QP	40.0	-8.7	1.25 V	10	46.30	-15.00
2	99.84	36.1 QP	43.5	-7.4	1.00 V	331	54.90	-18.80
3	586.78	31.8 QP	46.0	-14.2	1.00 V	158	38.20	-6.40
4	631.40	32.0 QP	46.0	-14.0	2.00 V	316	37.80	-5.80
5	800.18	33.9 QP	46.0	-12.1	1.50 V	209	36.70	-2.80
6	951.50	37.2 QP	46.0	-8.8	1.00 V	358	37.30	-0.10

REMARKS:

1. Emission Level(dBuV/m) = Raw Value(dBuV) + Correction Factor(dB/m)
2. Correction Factor (dB/m) = Antenna Factor (dB/m) + Cable Factor (dB)
– Pre-Amplifier Factor (dB).
3. The other emission levels were very low against the limit.
4. Margin value = Emission Level – Limit value

EUT TEST CONDITION		MEASUREMENT DETAIL	
CHANNEL	Channel 2 (908.40MHz)	FREQUENCY RANGE	Below 1000MHz
INPUT POWER	120Vac, 60Hz	DETECTOR FUNCTION	Quasi-Peak
ENVIRONMENTAL CONDITIONS	26deg. C, 69%RH	TESTED BY	Brad Tung

ANTENNA POLARITY & TEST DISTANCE: HORIZONTAL AT 3 M								
NO.	FREQ. (MHz)	EMISSION LEVEL (dBuV/m)	LIMIT (dBuV/m)	MARGIN (dB)	ANTENNA HEIGHT (m)	TABLE ANGLE (Degree)	RAW VALUE (dBuV)	CORRECTION FACTOR (dB/m)
1	35.82	27.7 QP	40.0	-12.3	1.50 H	12	42.70	-15.00
2	142.52	32.4 QP	43.5	-11.1	2.00 H	330	46.70	-14.30
3	198.78	36.5 QP	43.5	-7.0	1.00 H	98	53.20	-16.70
4	317.12	30.6 QP	46.0	-15.4	1.25 H	97	42.70	-12.10
5	600.36	32.4 QP	46.0	-13.6	2.00 H	96	38.60	-6.20
6	631.40	34.7 QP	46.0	-11.3	1.00 H	93	40.50	-5.80
ANTENNA POLARITY & TEST DISTANCE: VERTICAL AT 3 M								
NO.	FREQ. (MHz)	EMISSION LEVEL (dBuV/m)	LIMIT (dBuV/m)	MARGIN (dB)	ANTENNA HEIGHT (m)	TABLE ANGLE (Degree)	RAW VALUE (dBuV)	CORRECTION FACTOR (dB/m)
1	35.82	35.5 QP	40.0	-4.5	1.50 V	313	50.50	-15.00
2	99.84	36.4 QP	43.5	-7.1	1.00 V	299	55.20	-18.80
3	198.78	25.3 QP	43.5	-18.2	1.00 V	174	42.00	-16.70
4	588.72	32.3 QP	46.0	-13.7	1.25 V	311	38.70	-6.40
5	633.34	31.4 QP	46.0	-14.6	2.00 V	61	37.10	-5.70
6	947.62	36.9 QP	46.0	-9.1	2.00 V	135	37.10	-0.20

REMARKS:

1. Emission Level(dBuV/m) = Raw Value(dBuV) + Correction Factor(dB/m)
2. Correction Factor (dB/m) = Antenna Factor (dB/m) + Cable Factor (dB)
– Pre-Amplifier Factor (dB).
3. The other emission levels were very low against the limit.
4. Margin value = Emission Level – Limit value



A D T

EUT TEST CONDITION		MEASUREMENT DETAIL	
CHANNEL	Channel 3 (916.00MHz)	FREQUENCY RANGE	Below 1000MHz
INPUT POWER	120Vac, 60Hz	DETECTOR FUNCTION	Quasi-Peak
ENVIRONMENTAL CONDITIONS	26deg. C, 69%RH	TESTED BY	Brad Tung

ANTENNA POLARITY & TEST DISTANCE: HORIZONTAL AT 3 M								
NO.	FREQ. (MHz)	EMISSION LEVEL (dBuV/m)	LIMIT (dBuV/m)	MARGIN (dB)	ANTENNA HEIGHT (m)	TABLE ANGLE (Degree)	RAW VALUE (dBuV)	CORRECTION FACTOR (dB/m)
1	35.82	27.3 QP	40.0	-12.7	1.25 H	13	42.30	-15.00
2	119.24	30.5 QP	43.5	-13.0	2.00 H	117	47.00	-16.50
3	198.78	34.8 QP	43.5	-8.7	1.00 H	80	51.50	-16.70
4	239.52	34.0 QP	46.0	-12.0	1.00 H	189	49.00	-15.00
5	260.86	33.4 QP	46.0	-12.6	1.50 H	86	47.40	-14.00
6	600.36	36.6 QP	46.0	-9.4	1.25 H	82	42.80	-6.20

ANTENNA POLARITY & TEST DISTANCE: VERTICAL AT 3 M								
NO.	FREQ. (MHz)	EMISSION LEVEL (dBuV/m)	LIMIT (dBuV/m)	MARGIN (dB)	ANTENNA HEIGHT (m)	TABLE ANGLE (Degree)	RAW VALUE (dBuV)	CORRECTION FACTOR (dB/m)
1	35.82	35.0 QP	40.0	-5.0	1.25 V	326	50.00	-15.00
2	53.28	30.2 QP	40.0	-9.8	1.50 V	26	44.10	-13.90
3	99.84	36.2 QP	43.5	-7.3	1.00 V	296	55.00	-18.80
4	588.72	34.2 QP	46.0	-11.8	2.00 V	357	40.60	-6.40
5	798.24	34.3 QP	46.0	-11.7	1.25 V	192	37.10	-2.80
6	904.94	36.9 QP	46.0	-9.1	1.50 V	9	37.90	-1.00

REMARKS:

1. Emission Level(dBuV/m) = Raw Value(dBuV) + Correction Factor(dB/m)
2. Correction Factor (dB/m) = Antenna Factor (dB/m) + Cable Factor (dB) – Pre-Amplifier Factor (dB).
3. The other emission levels were very low against the limit.
4. Margin value = Emission Level – Limit value



4.2 CONDUCTED EMISSION MEASUREMENT

4.2.1 LIMITS OF CONDUCTED EMISSION MEASUREMENT

FREQUENCY OF EMISSION (MHz)	CONDUCTED LIMIT (dB μ V)	
	Quasi-peak	Average
0.15-0.5	66 to 56	56 to 46
0.5-5	56	46
5-30	60	50

- NOTE:**
1. The lower limit shall apply at the transition frequencies.
 2. The limit decreases in line with the logarithm of the frequency in the range of 0.15 to 0.50 MHz.
 3. All emanations from a class A/B digital device or system, including any network of conductors and apparatus connected thereto, shall not exceed the level of field strengths specified above.

4.2.2 TEST INSTRUMENTS

DESCRIPTION & MANUFACTURER	MODEL NO.	SERIAL NO.	DATE OF CALIBRATION	DUE DATE OF CALIBRATION
Test Receiver ROHDE & SCHWARZ	ESCS30	100288	Nov. 09, 2012	Nov. 08, 2013
RF signal cable Woken	5D-FB	Cable-HYCO2-01	Dec. 28, 2012	Dec. 27, 2013
LISN ROHDE & SCHWARZ (EUT)	ESH2-Z5	100100	Dec. 21, 2012	Dec. 20, 2013
LISN ROHDE & SCHWARZ (Peripheral)	ESH3-Z5	100312	Jul. 02, 2013	Jul. 01, 2014
Software ADT	BV ADT_Cond_ V7.3.7.3	NA	NA	NA

- NOTE:**
1. The calibration interval of the above test instruments is 12 months and the calibrations are traceable to NML/ROC and NIST/USA.
 2. The test was performed in HwaYa Shielded Room 2.
 3. The VCCI Site Registration No. is C-2047.

4.2.3 TEST PROCEDURES

- a. The EUT was placed 0.4 meters from the conducting wall of the shielded room with EUT being connected to the power mains through a line impedance stabilization network (LISN). Other support units were connected to the power mains through another LISN. The two LISNs provide 50 ohm/ 50uH of coupling impedance for the measuring instrument.
- b. Both lines of the power mains connected to the EUT were checked for maximum conducted interference.
- c. The frequency range from 150kHz to 30MHz was searched. Emission levels under (Limit - 20dB) was not recorded.

NOTE: All modes of operation were investigated and the worst-case emissions are reported.

4.2.4 DEVIATION FROM TEST STANDARD

No deviation.

4.2.5 TEST SETUP

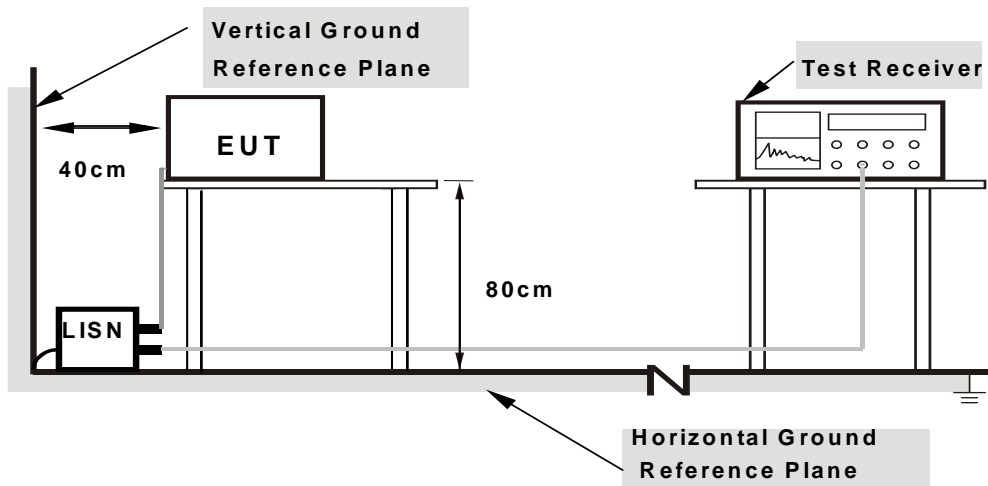

- Note:**
- 1.Support units were connected to second LISN.
 - 2.Both of LISNs (AMN) are 80 cm from EUT and at least 80 from other units and other metal planes

For the actual test configuration, please refer to the attached file (Test Setup Photo).

4.2.6 EUT OPERATING CONDITIONS

Same as 4.1.6.

4.2.7 TEST RESULTS

CONDUCTED WORST-CASE DATA :

CHANNEL	Channel 1 (908.42MHz)	PHASE	Line 1
6dB BANDWIDTH	9kHz		

No	Freq. [MHz]	Corr. Factor (dB)	Reading Value		Emission Level		Limit		Margin	
			[dB (uV)]		[dB (uV)]		[dB (uV)]		(dB)	
			Q.P.	AV.	Q.P.	AV.	Q.P.	AV.	Q.P.	AV.
1	0.16562	0.19	31.06	20.72	31.25	20.91	65.18	55.18	-33.93	-34.27
2	0.51210	0.23	40.02	39.54	40.25	39.77	56.00	46.00	-15.75	-6.23
3	0.61094	0.24	29.86	23.31	30.10	23.55	56.00	46.00	-25.90	-22.45
4	1.53516	0.31	30.65	24.87	30.96	25.18	56.00	46.00	-25.04	-20.82
5	2.20703	0.33	28.00	19.30	28.33	19.63	56.00	46.00	-27.67	-26.37
6	12.64453	0.55	24.54	17.18	25.09	17.73	60.00	50.00	-34.91	-32.27

REMARKS:

1. Q.P. and AV. are abbreviations of quasi-peak and average individually.
2. The emission levels of other frequencies were very low against the limit.
3. Margin value = Emission level - Limit value
4. Correction factor = Insertion loss + Cable loss
5. Emission Level = Correction Factor + Reading Value

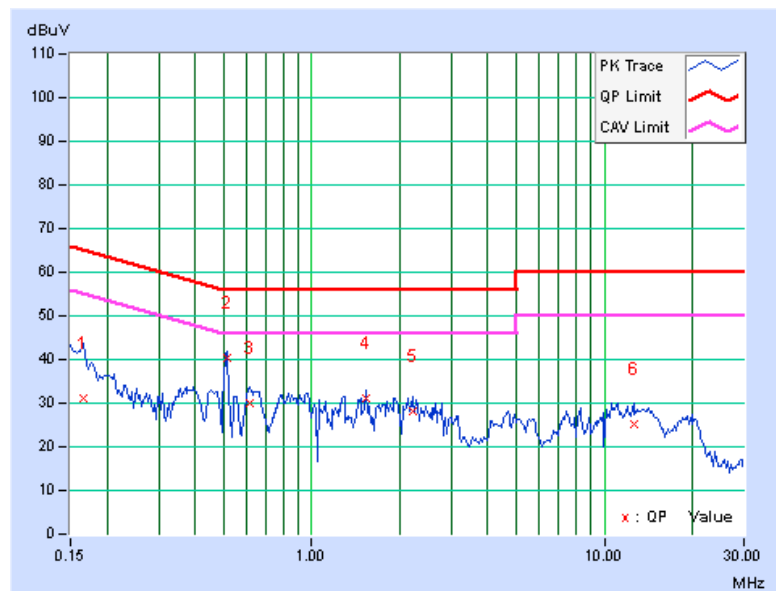

CHANNEL	Channel 1 (908.42MHz)	PHASE	Line 2
6dB BANDWIDTH	9kHz		

No	Freq. [MHz]	Corr. Factor (dB)	Reading Value		Emission Level		Limit		Margin	
			[dB (uV)]		[dB (uV)]		[dB (uV)]		(dB)	
			Q.P.	AV.	Q.P.	AV.	Q.P.	AV.	Q.P.	AV.
1	0.16953	0.18	29.90	15.92	30.08	16.10	56.00	46.00	-25.92	-29.90
2	0.51328	0.25	39.04	36.70	39.29	36.95	56.00	46.00	-16.71	-9.05
3	0.61484	0.24	29.32	14.62	29.56	14.86	56.00	46.00	-26.44	-31.14
4	1.89453	0.27	25.73	18.80	26.00	19.07	56.00	46.00	-30.00	-26.93
5	2.32031	0.30	23.66	16.66	23.96	16.96	56.00	46.00	-32.04	-29.04
6	11.08984	0.51	25.66	17.41	26.17	17.92	60.00	50.00	-33.83	-32.08

REMARKS:

1. Q.P. and AV. are abbreviations of quasi-peak and average individually.
2. The emission levels of other frequencies were very low against the limit.
3. Margin value = Emission level - Limit value
4. Correction factor = Insertion loss + Cable loss
5. Emission Level = Correction Factor + Reading Value

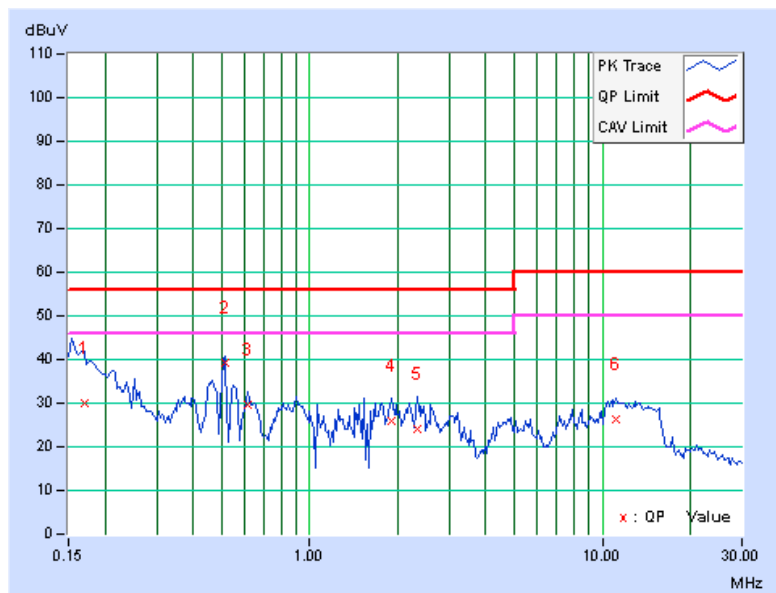

CHANNEL	Channel 2 (908.40MHz)	PHASE	Line 1
6dB BANDWIDTH	9kHz		

No	Freq. [MHz]	Corr. Factor (dB)	Reading Value		Emission Level		Limit		Margin	
			[dB (uV)]		[dB (uV)]		[dB (uV)]		(dB)	
			Q.P.	AV.	Q.P.	AV.	Q.P.	AV.	Q.P.	AV.
1	0.16172	0.19	31.16	20.91	31.35	21.10	65.38	55.38	-34.03	-34.28
2	0.51328	0.23	40.00	38.32	40.23	38.55	56.00	46.00	-15.77	-7.45
3	0.61875	0.25	28.20	19.08	28.45	19.33	56.00	46.00	-27.55	-26.67
4	1.46094	0.30	26.64	19.07	26.94	19.37	56.00	46.00	-29.06	-26.63
5	2.13281	0.33	29.31	20.07	29.64	20.40	56.00	46.00	-26.36	-25.60
6	12.38281	0.55	25.63	16.97	26.18	17.52	60.00	50.00	-33.82	-32.48

REMARKS:

1. Q.P. and AV. are abbreviations of quasi-peak and average individually.
2. The emission levels of other frequencies were very low against the limit.
3. Margin value = Emission level - Limit value
4. Correction factor = Insertion loss + Cable loss
5. Emission Level = Correction Factor + Reading Value

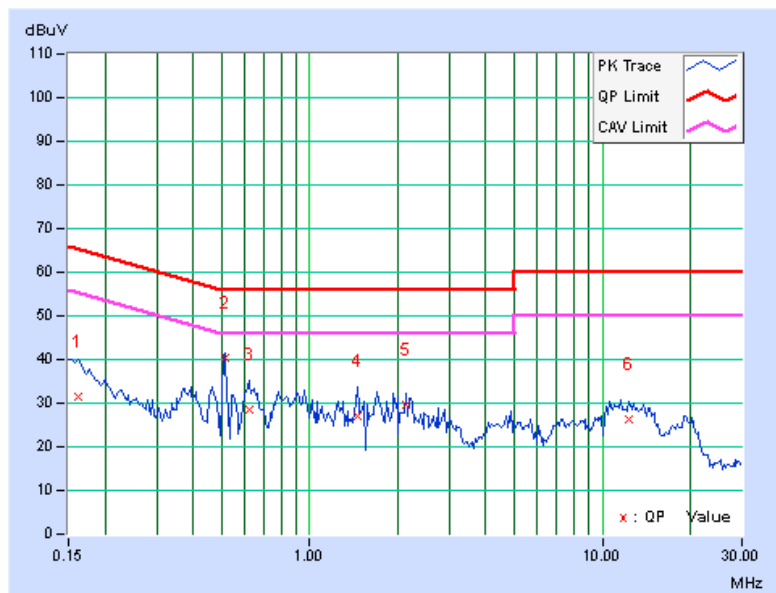

CHANNEL	Channel 2 (908.40MHz)	PHASE	Line 2
6dB BANDWIDTH	9kHz		

No	Freq. [MHz]	Corr. Factor (dB)	Reading Value		Emission Level		Limit		Margin	
			[dB (uV)]		[dB (uV)]		[dB (uV)]		(dB)	
			Q.P.	AV.	Q.P.	AV.	Q.P.	AV.	Q.P.	AV.
1	0.17734	0.19	29.50	16.42	29.69	16.61	64.61	54.61	-34.92	-38.00
2	0.51328	0.27	39.00	37.96	39.27	38.23	56.00	46.00	-16.73	-7.77
3	0.61875	0.27	27.02	16.62	27.29	16.89	56.00	46.00	-28.71	-29.11
4	1.24609	0.27	26.21	19.75	26.48	20.02	56.00	46.00	-29.52	-25.98
5	2.19922	0.33	27.95	18.87	28.28	19.20	56.00	46.00	-27.72	-26.80
6	11.66016	0.61	24.82	17.54	25.43	18.15	60.00	50.00	-34.57	-31.85

REMARKS:

1. Q.P. and AV. are abbreviations of quasi-peak and average individually.
2. The emission levels of other frequencies were very low against the limit.
3. Margin value = Emission level - Limit value
4. Correction factor = Insertion loss + Cable loss
5. Emission Level = Correction Factor + Reading Value

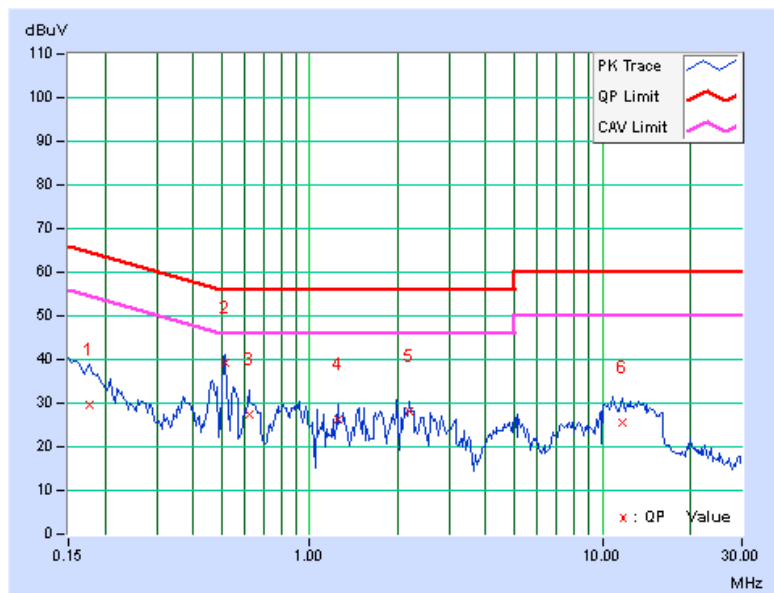

CHANNEL	Channel 3 (916.00MHz)	PHASE	Line 1
6dB BANDWIDTH	9kHz		

No	Freq. [MHz]	Corr. Factor (dB)	Reading Value		Emission Level		Limit		Margin	
			[dB (uV)]		[dB (uV)]		[dB (uV)]		(dB)	
			Q.P.	AV.	Q.P.	AV.	Q.P.	AV.	Q.P.	AV.
1	0.18516	0.20	29.01	20.29	29.21	20.49	64.25	54.25	-35.05	-33.77
2	0.51328	0.23	39.92	38.82	40.15	39.05	56.00	46.00	-15.85	-6.95
3	0.62266	0.25	29.34	22.11	29.59	22.36	56.00	46.00	-26.41	-23.64
4	1.67578	0.31	26.50	19.61	26.81	19.92	56.00	46.00	-29.19	-26.08
5	2.13672	0.33	28.74	19.27	29.07	19.60	56.00	46.00	-26.93	-26.40
6	11.94141	0.54	25.80	17.61	26.34	18.15	60.00	50.00	-33.66	-31.85

REMARKS:

1. Q.P. and AV. are abbreviations of quasi-peak and average individually.
2. The emission levels of other frequencies were very low against the limit.
3. Margin value = Emission level - Limit value
4. Correction factor = Insertion loss + Cable loss
5. Emission Level = Correction Factor + Reading Value

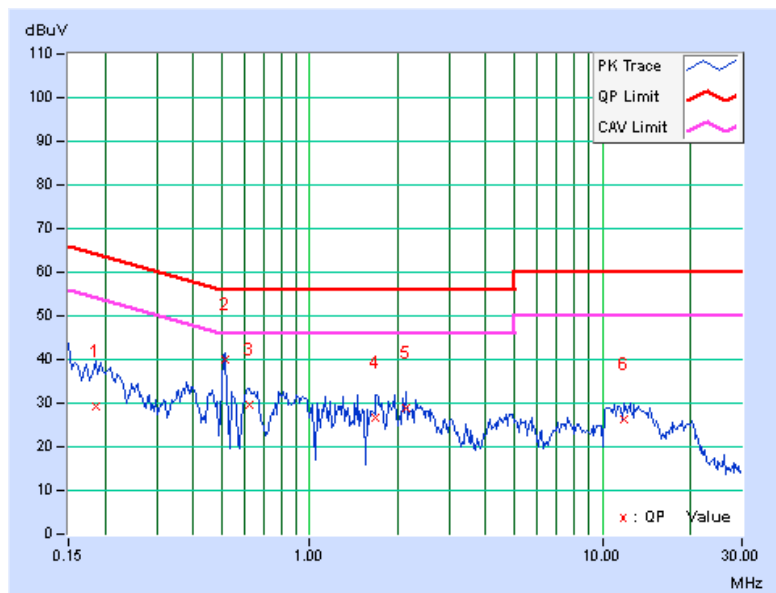

CHANNEL	Channel 3 (916.00MHz)	PHASE	Line 2
6dB BANDWIDTH	9kHz		

No	Freq. [MHz]	Corr. Factor (dB)	Reading Value		Emission Level		Limit		Margin	
			[dB (uV)]		[dB (uV)]		[dB (uV)]		(dB)	
			Q.P.	AV.	Q.P.	AV.	Q.P.	AV.	Q.P.	AV.
1	0.17734	0.18	28.92	16.18	29.10	16.36	64.61	54.61	-35.51	-38.25
2	0.51328	0.25	38.92	37.57	39.17	37.82	56.00	46.00	-16.83	-8.18
3	0.62288	0.24	34.28	18.73	34.52	18.97	56.00	46.00	-21.48	-27.03
4	1.53125	0.26	29.02	23.49	29.28	23.75	56.00	46.00	-26.72	-22.25
5	2.12500	0.29	28.77	19.58	29.06	19.87	56.00	46.00	-26.94	-26.13
6	13.48047	0.57	24.34	15.96	24.91	16.53	60.00	50.00	-35.09	-33.47

REMARKS:

1. Q.P. and AV. are abbreviations of quasi-peak and average individually.
2. The emission levels of other frequencies were very low against the limit.
3. Margin value = Emission level - Limit value
4. Correction factor = Insertion loss + Cable loss
5. Emission Level = Correction Factor + Reading Value

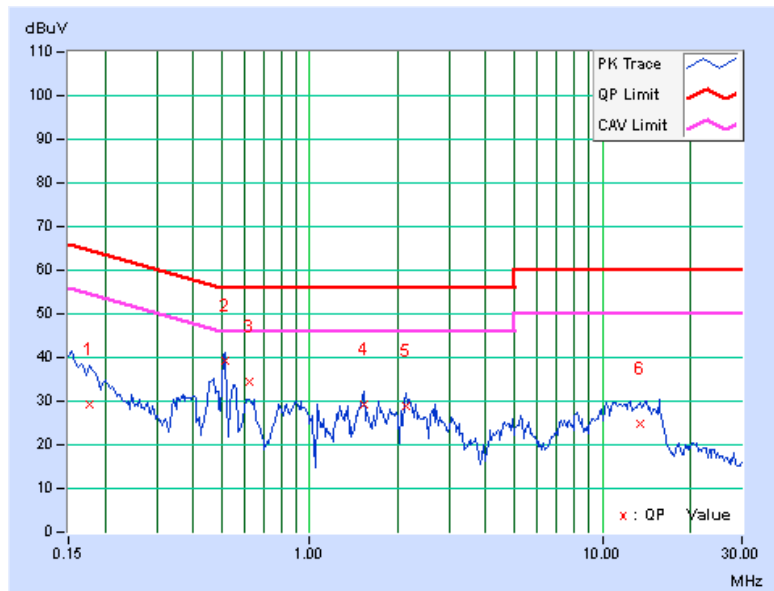

4.3 BAND EDGE MEASUREMENT

4.3.1 LIMITS OF BAND EDGE MEASUREMENT

The field strength of emissions from intentional radiators operated within these frequency bands shall comply with the following

Fundamental Frequency	Field Strength of Fundamental (millivolts/meter)	Field Strength of Harmonics (microvolts/meter)
902 ~ 928 MHz	50	500
2400 ~ 2483.5 MHz	50	500
5725 ~ 5875 MHz	50	500
24 ~ 24.25 GHz	250	2500

Emissions radiated outside of the specified frequency bands, except for harmonics, shall be attenuated by at least 50 dB below the level of the fundamental or to the general radiated emission limits as below table, whichever is the lesser attenuation

Frequencies (MHz)	Field strength (microvolts/meter)	Measurement distance (meters)
0.009 ~ 0.490	2400/F(kHz)	300
0.490 ~ 1.705	24000/F(kHz)	30
1.705 ~ 30.0	30	30
30 ~ 88	100	3
88 ~ 216	150	3
216 ~ 960	200	3
Above 960	500	3

NOTE:

1. The lower limit shall apply at the transition frequencies.
2. Emission level (dBuV/m) = 20 log Emission level (uV/m).
3. For frequencies above 1000MHz, the field strength limits are based on average detector, however, the peak field strength of any emission shall not exceed the maximum permitted average limits, specified above by more than 20dB under any condition of modulation.



4.3.2 TEST INSTRUMENTS

DESCRIPTION & MANUFACTURER	MODEL NO.	SERIAL NO.	DATE OF CALIBRATION	DUE DATE OF CALIBRATION
Test Receiver ROHDE & SCHWARZ	ESCS30	100289	Nov. 16, 2012	Nov. 15, 2013
Spectrum Analyzer ROHDE & SCHWARZ	FSP40	100269	Jan. 28, 2013	Jan. 27, 2014
BILOG Antenna SCHWARZBECK	VULB9168	9168-156	Mar. 22, 2013	Mar. 21, 2014
HORN Antenna SCHWARZBECK	BBHA 9120 D	9120D-209	Sep. 03, 2012	Sep. 02, 2013
HORN Antenna SCHWARZBECK	BBHA 9170	148	Jul. 15, 2013	Jul. 14, 2014
Loop Antenna	HFH2-Z2	100070	Jan. 31, 2012	Jan. 30, 2014
Preamplifier Agilent	8449B	3008A01911	Oct. 25, 2012	Oct. 24, 2013
Preamplifier Agilent	8447D	2944A10638	Oct. 25, 2012	Oct. 24, 2013
RF signal cable HUBER+SUHNNER	SUCOFLEX 104	295013/4 283403/4	Aug. 28, 2012	Aug. 27, 2013
RF signal cable Worken	8D-FB	Cable-HYCH9-01	Aug. 11, 2012	Aug. 10, 2013
Software BV ADT	ADT_Radiated_ V7.6.15.9.4	NA	NA	NA
Antenna Tower EMCO	2070/2080	512.835.4684	NA	NA
Turn Table EMCO	2087-2.03	NA	NA	NA
Antenna Tower & Turn Table Controller EMCO	2090	NA	NA	NA
Turn Table BV ADT	TT100.	TT93021704	NA	NA
Turn Table Controller BV ADT	SC100.	SC93021704	NA	NA

- NOTE:**
1. The calibration interval of the above test instruments is 12 months and the calibrations are traceable to NML/ROC and NIST/USA.
 2. The calibration interval of the loop antenna is 24 months and the calibrations are traceable to NML/ROC and NIST/USA.
 3. The test was performed in HwaYa Chamber 9.
 4. The horn antenna and HP preamplifier (model: 8449B) are used only for the measurement of emission frequency above 1GHz if tested.
 5. The FCC Site Registration No. is 215374.
 6. The IC Site Registration No. is IC 7450F-9.

4.3.3 TEST PROCEDURES

- a. The EUT was placed on the top of a rotating table 0.8 meters above the ground at a 3 meter semi-anechoic chamber. The table was rotated 360 degrees to determine the position of the highest radiation.
- b. The EUT was set 3 meters away from the interference-receiving antenna, which was mounted on the top of a variable-height antenna tower.
- c. The antenna is a broadband antenna, and its height is varied from one meter to four meters above the ground to determine the maximum value of the field strength. Both horizontal and vertical polarizations of the antenna are set to make the measurement.
- d. For each suspected emission, the EUT was arranged to its worst case and then the antenna was tuned to heights from 1 meter to 4 meters and the rotatable table was turned from 0 degrees to 360 degrees to find the maximum reading.
- e. The test-receiver system was set to Peak Detect Function and Specified Bandwidth with Maximum Hold Mode.
- f. If the emission level of the EUT in peak mode was lower than the limit specified, then testing could be stopped and the peak values of the EUT would be reported. Otherwise the emissions would be re-tested one by one using peak, quasi-peak or average method as specified and then reported in a data sheet.

NOTE:

1. The resolution bandwidth and video bandwidth of test receiver/spectrum analyzer is 120kHz for Quasi-peak detection at frequency below 1GHz.
2. The resolution bandwidth of test receiver/spectrum analyzer is 1MHz and video bandwidth is 3MHz for Peak detection at frequency above 1GHz.
3. The resolution bandwidth of test receiver/spectrum analyzer is 1MHz and the video bandwidth is 1kHz(Duty cycle < 98%) or 10Hz(Duty cycle > 98%) for Average detection (AV) at frequency above 1GHz.
4. All modes of operation were investigated and the worst-case emissions are reported.

4.3.4 DEVIATION FROM TEST STANDARD

No deviation.

4.3.5 TEST SETUP

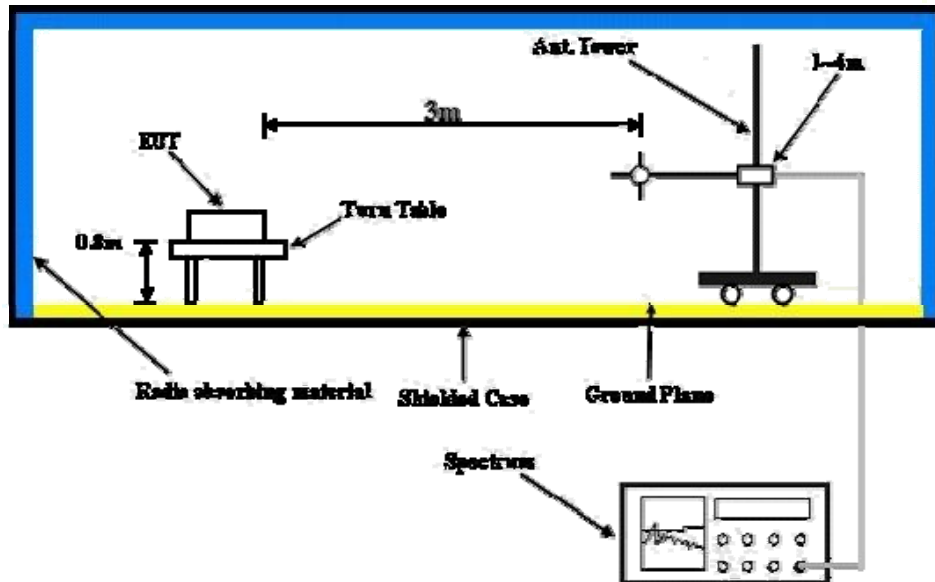

For the actual test configuration, please refer to the attached file (Test Setup Photo).

4.3.6 EUT OPERATING CONDITIONS

- a. Plugged EUT into notebook and placed them on the testing table.
- b. The notebook ran test program (provided by manufacturer) to enable EUT under transmission condition continuously at specific channel frequency.

4.3.7 TEST RESULTS

EUT TEST CONDITION		MEASUREMENT DETAIL	
CHANNEL	Channel 1 (908.42MHz)	FREQUENCY RANGE	Below 1000MHz
INPUT POWER	120Vac, 60 Hz	DETECTOR FUNCTION	Peak (PK)
ENVIRONMENTAL CONDITIONS	26deg. C, 69%RH	TESTED BY	Brad Tung

ANTENNA POLARITY & TEST DISTANCE: HORIZONTAL AT 3 M								
NO.	FREQ. (MHz)	EMISSION LEVEL (dBuV/m)	LIMIT (dBuV/m)	MARGIN (dB)	ANTENNA HEIGHT (m)	TABLE ANGLE (Degree)	RAW VALUE (dBuV)	CORRECTION FACTOR (dB/m)
1	905.69	34.3 PK	42.8	-8.5	1.00 H	163	7.60	26.70
2	*908.42	92.8 PK			-	-	65.90	26.90
3	909.85	34.2 PK	42.8	-8.6	1.00 H	145	7.30	26.90

- REMARKS:**
1. Emission level (dBuV/m) = Raw Value (dBuV) + Correction Factor (dB/m).
 2. Correction Factor (dB/m) = Antenna Factor (dB/m) + Cable Factor (dB) – Pre-Amplifier Factor (dB).
 3. The other emission levels were very low against the limit.
 4. Margin value = Emission level – Limit value.
 5. “ * “ : Fundamental frequency

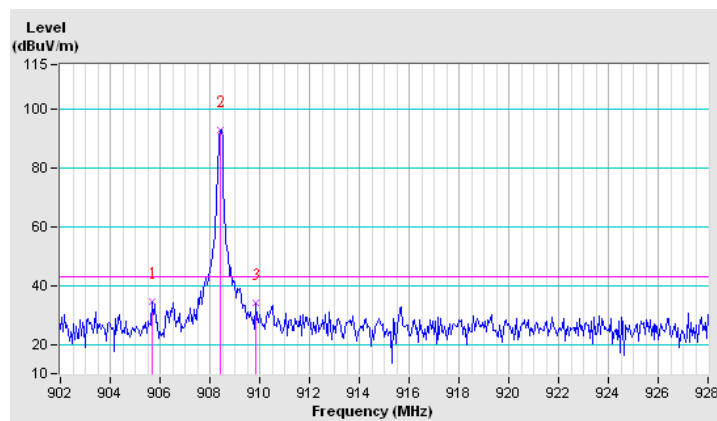

EUT TEST CONDITION		MEASUREMENT DETAIL	
CHANNEL	Channel 1 (908.42MHz)	FREQUENCY RANGE	Below 1000MHz
INPUT POWER	120Vac, 60 Hz	DETECTOR FUNCTION	Peak (PK)
ENVIRONMENTAL CONDITIONS	26deg. C, 69%RH	TESTED BY	Brad Tung

ANTENNA POLARITY & TEST DISTANCE: VERTICAL AT 3 M								
NO.	FREQ. (MHz)	EMISSION LEVEL (dBuV/m)	LIMIT (dBuV/m)	MARGIN (dB)	ANTENNA HEIGHT (m)	TABLE ANGLE (Degree)	RAW VALUE (dBuV)	CORRECTION FACTOR (dB/m)
1	906.52	31.8 PK	41.6	-9.8	1.00 V	103	5.00	26.80
2	*908.42	91.6 PK			-	-	64.70	26.90
3	910.32	32.7 PK	41.6	-8.9	1.00 V	54	5.80	26.90

- REMARKS:**
- Emission level (dBuV/m) = Raw Value (dBuV) + Correction Factor (dB/m).
 - Correction Factor (dB/m) = Antenna Factor (dB/m) + Cable Factor (dB) – Pre-Amplifier Factor (dB).
 - The other emission levels were very low against the limit.
 - Margin value = Emission level – Limit value.
 - “ * “ : Fundamental frequency

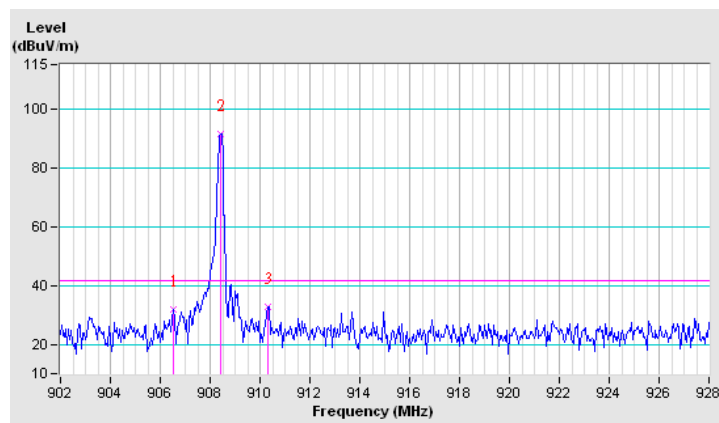

EUT TEST CONDITION		MEASUREMENT DETAIL	
CHANNEL	Channel 2 (908.40MHz)	FREQUENCY RANGE	Below 1000MHz
INPUT POWER	120Vac, 60 Hz	DETECTOR FUNCTION	Peak (PK)
ENVIRONMENTAL CONDITIONS	26deg. C, 69%RH	TESTED BY	Brad Tung

ANTENNA POLARITY & TEST DISTANCE: HORIZONTAL AT 3 M								
NO.	FREQ. (MHz)	EMISSION LEVEL (dBuV/m)	LIMIT (dBuV/m)	MARGIN (dB)	ANTENNA HEIGHT (m)	TABLE ANGLE (Degree)	RAW VALUE (dBuV)	CORRECTION FACTOR (dB/m)
1	906.32	32.7 PK	42.9	-10.2	1.06 H	231	5.90	26.80
2	*908.40	92.9 PK			-	-	66.00	26.90
3	910.11	32.8 PK	42.9	-10.1	1.10 H	22	5.90	26.90

- REMARKS:**
1. Emission level (dBuV/m) = Raw Value (dBuV) + Correction Factor (dB/m).
 2. Correction Factor (dB/m) = Antenna Factor (dB/m) + Cable Factor (dB) – Pre-Amplifier Factor (dB).
 3. The other emission levels were very low against the limit.
 4. Margin value = Emission level – Limit value.
 5. “ * “ : Fundamental frequency

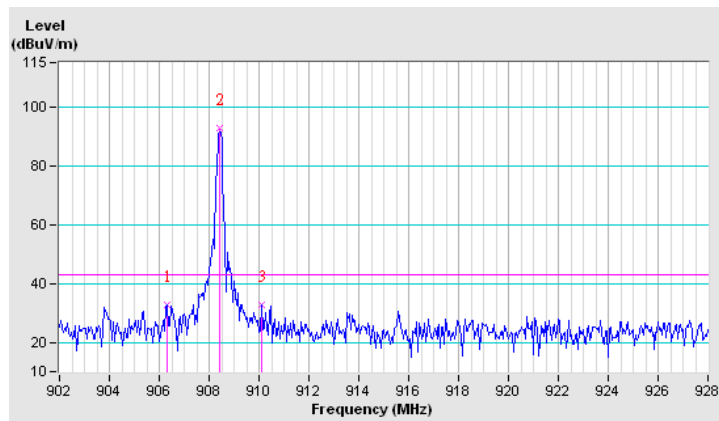

EUT TEST CONDITION		MEASUREMENT DETAIL	
CHANNEL	Channel 2 (908.40MHz)	FREQUENCY RANGE	Below 1000MHz
INPUT POWER	120Vac, 60 Hz	DETECTOR FUNCTION	Peak (PK)
ENVIRONMENTAL CONDITIONS	26deg. C, 69%RH	TESTED BY	Brad Tung

ANTENNA POLARITY & TEST DISTANCE: VERTICAL AT 3 M								
NO.	FREQ. (MHz)	EMISSION LEVEL (dBuV/m)	LIMIT (dBuV/m)	MARGIN (dB)	ANTENNA HEIGHT (m)	TABLE ANGLE (Degree)	RAW VALUE (dBuV)	CORRECTION FACTOR (dB/m)
1	906.52	31.9 PK	41.8	-9.9	1.00 V	24	5.10	26.80
2	908.40	91.8 PK			-	-	64.90	26.90
3	911.46	31.2 PK	41.8	-10.6	1.00 V	93	4.30	26.90

- REMARKS:**
- Emission level (dBuV/m) = Raw Value (dBuV) + Correction Factor (dB/m).
 - Correction Factor (dB/m) = Antenna Factor (dB/m) + Cable Factor (dB) – Pre-Amplifier Factor (dB).
 - The other emission levels were very low against the limit.
 - Margin value = Emission level – Limit value.
 - “ * “ : Fundamental frequency

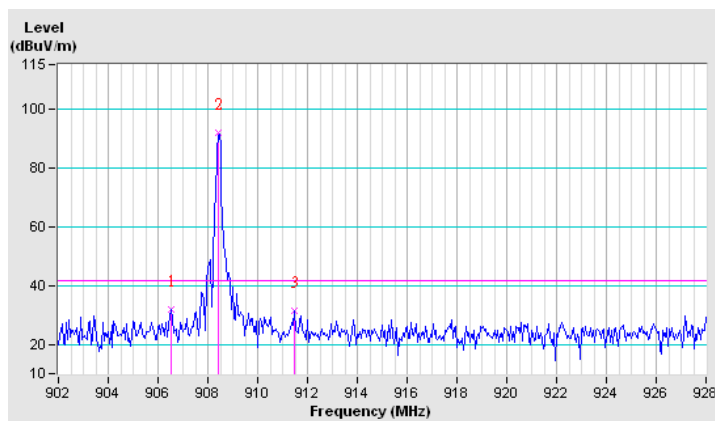

EUT TEST CONDITION		MEASUREMENT DETAIL	
CHANNEL	Channel 3 (916.00MHz)	FREQUENCY RANGE	Below 1000MHz
INPUT POWER	120Vac, 60 Hz	DETECTOR FUNCTION	Peak (PK)
ENVIRONMENTAL CONDITIONS	26deg. C, 69%RH	TESTED BY	Brad Tung

ANTENNA POLARITY & TEST DISTANCE: HORIZONTAL AT 3 M								
NO.	FREQ. (MHz)	EMISSION LEVEL (dBuV/m)	LIMIT (dBuV/m)	MARGIN (dB)	ANTENNA HEIGHT (m)	TABLE ANGLE (Degree)	RAW VALUE (dBuV)	CORRECTION FACTOR (dB/m)
1	910.06	38.9 PK	43.8	-4.9	1.10 H	13	12.00	26.90
2	916.00	93.8 PK			-	-	66.80	27.00
3	918.02	36.7 PK	43.8	-7.1	1.04 H	174	9.60	27.10

- REMARKS:**
1. Emission level (dBuV/m) = Raw Value (dBuV) + Correction Factor (dB/m).
 2. Correction Factor (dB/m) = Antenna Factor (dB/m) + Cable Factor (dB) – Pre-Amplifier Factor (dB).
 3. The other emission levels were very low against the limit.
 4. Margin value = Emission level – Limit value.
 5. “ * “ : Fundamental frequency

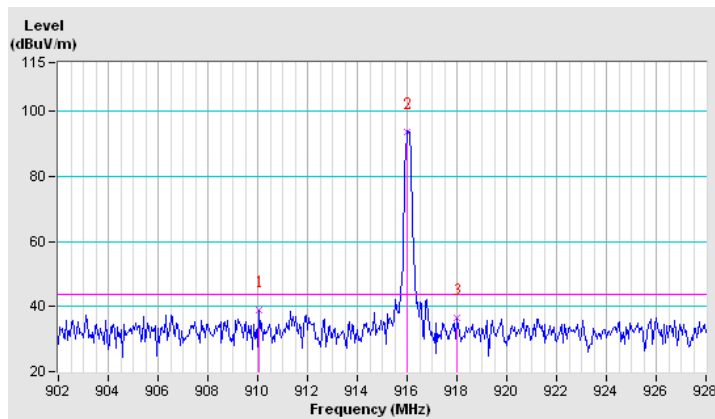

EUT TEST CONDITION		MEASUREMENT DETAIL	
CHANNEL	Channel 3 (916.00MHz)	FREQUENCY RANGE	Below 1000MHz
INPUT POWER	120Vac, 60 Hz	DETECTOR FUNCTION	Peak (PK)
ENVIRONMENTAL CONDITIONS	26deg. C, 69%RH	TESTED BY	Brad Tung

ANTENNA POLARITY & TEST DISTANCE: VERTICAL AT 3 M								
NO.	FREQ. (MHz)	EMISSION LEVEL (dBuV/m)	LIMIT (dBuV/m)	MARGIN (dB)	ANTENNA HEIGHT (m)	TABLE ANGLE (Degree)	RAW VALUE (dBuV)	CORRECTION FACTOR (dB/m)
1	912.14	36.2 PK	42.3	-6.1	1.00 V	3	9.30	26.90
2	916.00	92.3 PK			-	-	65.30	27.00
3	917.65	39.7 PK	42.3	-2.6	1.06 V	57	12.70	27.00

- REMARKS:**
1. Emission level (dBuV/m) = Raw Value (dBuV) + Correction Factor (dB/m).
 2. Correction Factor (dB/m) = Antenna Factor (dB/m) + Cable Factor (dB) – Pre-Amplifier Factor (dB).
 3. The other emission levels were very low against the limit.
 4. Margin value = Emission level – Limit value.
 5. “ * “ : Fundamental frequency

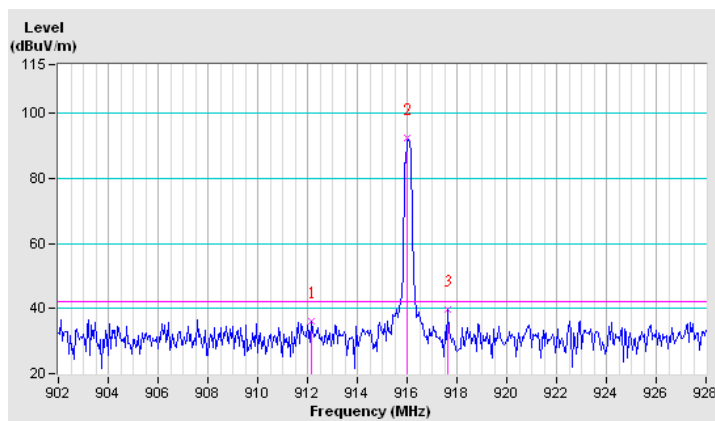



A D T

5. PHOTOGRAPHS OF THE TEST CONFIGURATION

Please refer to the attached file (Test Setup Photo).



6. INFORMATION ON THE TESTING LABORATORIES

We, Bureau Veritas Consumer Products Services (H.K.) Ltd., Taoyuan Branch, were founded in 1988 to provide our best service in EMC, Radio, Telecom and Safety consultation. Our laboratories are accredited and approved according to ISO/IEC 17025.

If you have any comments, please feel free to contact us at the following:

Linko EMC/RF Lab

Tel: 886-2-26052180

Fax: 886-2-26051924

Hsin Chu EMC/RF Lab

Tel: 886-3-5935343

Fax: 886-3-5935342

Hwa Ya EMC/RF/Safety/Telecom Lab

Tel: 886-3-3183232

Fax: 886-3-3270892

Email: service.adt@tw.bureauveritas.com

Web Site: www.bureauveritas-adt.com

The address and road map of all our labs can be found in our web site also.



A D T

7. APPENDIX A - MODIFICATIONS RECORDERS FOR ENGINEERING CHANGES TO THE EUT BY THE LAB

No any modifications are made to the EUT by the lab during the test.

--- END ---