

Test report No. : 27IE0024-HO-E-R1  
Page : 52 of 84  
Issued date : September 25, 2007  
Revised date : November 18, 2007  
FCC ID : D7LNT511

---

## APPENDIX 2 : Test instruments

---

**UL Japan, Inc.**  
**Head Office EMC Lab.**  
4383-326 Asama-cho, Ise-shi, Mie-ken 516-0021 JAPAN  
Telephone : +81 596 24 8116  
Facsimile : +81 596 24 8124

**1. Equipment used**

Control No.	Name of Equipment	Manufacture	Model number	Serial number	Calibration	
					Last Cal	due date
MPM-01	Power Meter	Agilent	8449B	3008A01671	2007/02/15	2008/02/29
MPSE-01	Power sensor	Agilent	E9300B	US40010300	2006/12/20	2007/12/31
MPSE-03	Power sensor	Agilent	E9327A	US40440576	2007/01/10	2008/01/31
MAT-15	Attenuator(30dB)	Agilent	US40010300	08498-60012	2006/12/20	2007/12/31
MPM-09	Power Meter	Anritsu	ML2495A	6K00003348	2006/09/20	2007/09/30
MPSE-12	Power sensor	Anritsu	MA2411B	011598	2006/09/20	2007/09/30
MAT-23	Attenuator(10dB) DC-18GHz	Orient Microwave	BX10-0476-00	-	2007/03/07	2008/03/31
MCC-06	Microwave Cable 1G-26.5GHz 1m	Suhner	SUCOFLEX 104	233011/4	2007/02/26	2008/02/29
MOS-04	Digital Humidity Indicator	N.T	NT-1800	MOS04	2006/11/27	2007/11/30
MSG-05	Signal Genelator	Agilent	E4438C	MY45090353	2007/06/20	2008/06/30
MRFA-02	RF Amplifier	OPHIR	5056F	1005	2007/06/01	2008/06/30
MHDC-12	Directional Coupler	Hewlett Packard	772D	2839A0016	-	-
MNA-01	Network Analyzer	Agilent	E8358A	US41080381	2006/02/10	2009/02/28
MPB-03	Dosimetric E-Field Probe	Schmid&Partner Engineering AG	EX3DV3	3507	2007/06/15	2008/06/30
MDAE-01	Data Acquisition Electronics	Schmid&Partner Engineering AG	DAE3 V1	509	2007/06/13	2008/06/30
MSTW-16	SAR measurement System	Schmid&Partner Engineering AG	DASY4	I021834	-	-
MDA-07	2450MHz System Validation Dipole	Schmid&Partner Engineering AG	D2450V2	713	2006/09/27	2007/09/31
MPF-01	Flat Phantom	Schmid&Partner Engineering AG	2.0mm Flat Phantom V4.3L	1005	-	-
MDPK-01	Dielectric probe kit	Agilent	85070D	-	-	-
MOS-05	Thermo-Hygrometer	Custom	CTH-190	810201	2006/04/25	2008/04/30
MOS-10	Digital thermometer	HANNA	Checktemp-2	MOS-10	2007/03/23	2009/03/31
	Body 2450MHz	-	-	-	Daily check	Target value ± 5%
	SAR room	-	-	-	Daily check	Ambient Noise<0.012W/kg

The expiration date of the calibration is the end of the expired month.

All equipment is calibrated with traceable calibrations. Each calibration is traceable to the national or international standards.

\*Some calibrations were performed after the tested dates, however those EMI test equipment have been controlled by means of an unbroken chains of calibrations.

**UL Japan, Inc.**

**Head Office EMC Lab.**

4383-326 Asama-cho, Ise-shi, Mie-ken 516-0021 JAPAN

Telephone : +81 596 24 8116

Facsimile : +81 596 24 8124

## 2. Dosimetry assessment setup

These measurements were performed with the automated near-field scanning system DASY4 from Schmid & Partner Engineering AG (SPEAG). The system is based on a high precision robot (working range greater than 0.9 m), which positions the probes with a positional repeatability of better than +/- 0.02 mm. Special E- and H-field probes have been developed for measurements close to material discontinuity, the sensors of which are directly loaded with a Schottky diode and connected via highly resistive lines to the data acquisition unit. The SAR measurements were conducted with the dosimetry probes EX3DV4, SN: 3507 (manufactured by SPEAG), designed in the classical triangular configuration and optimized for dosimetric evaluation. The probe has been calibrated according to the procedure described in [2] with accuracy of better than +/-10%. The spherical isotropy was evaluated with the procedure described in [3] and found to be better than +/-0.25 dB. The used phantom was the Flat Phantom as described in EN50383.

---

**UL Japan, Inc.**

**Head Office EMC Lab.**

4383-326 Asama-cho, Ise-shi, Mie-ken 516-0021 JAPAN

Telephone : +81 596 24 8116

Facsimile : +81 596 24 8124

### 3. Configuration and peripherals

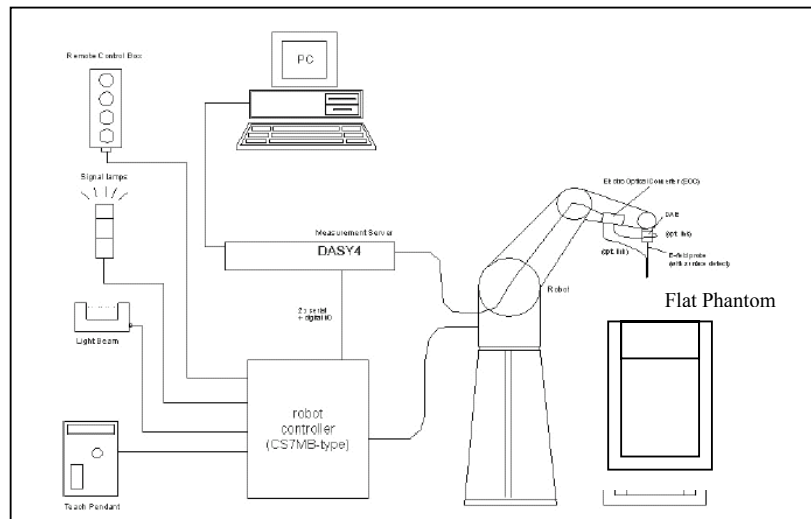

The DASY4 system for performing compliance tests consist of the following items:

1. A standard high precision 6-axis robot (Stäubli RX family) with controller and software.  
An arm extension for accommodating the data acquisition electronics (DAE).
  2. A dosimetric probe, i.e., an isotropic E-field probe optimized and calibrated for usage in tissue simulating liquid. The probe is equipped with an optical surface detector system.
  3. A data acquisition electronic (DAE), which performs the signal amplification, signal multiplexing, AD-conversion, offset measurements, mechanical surface detection, collision detection, etc. The unit is battery powered with standard or rechargeable batteries. The signal is optically transmitted to the EOC.
  4. The Electro-optical converter (EOC) performs the conversion between optical and electrical of the signals for the digital communication to the DAE and for the analog signal from the optical surface detection.  
The EOC is connected to the measurement server.
  5. The function of the measurement server is to perform the time critical tasks such as signal filtering, control of the robot operation and fast movement interrupts.
  6. A probe alignment unit which improves the (absolute) accuracy of the probe positioning.
  7. A computer operating Windows 2000.
  8. DASY4 software.
  9. Remote control with teaches pendant and additional circuitry for robot safety such as warning lamps, etc.
  10. The Flat phantom enabling testing of body.
  11. The device holder for EUT.(Palette)
  12. Tissue simulating liquid mixed according to the given recipes.
  13. Validation dipole kits allowing to validate the proper functioning of the system.
- 

#### **UL Japan, Inc.**

#### **Head Office EMC Lab.**

4383-326 Asama-cho, Ise-shi, Mie-ken 516-0021 JAPAN

Telephone : +81 596 24 8116

Facsimile : +81 596 24 8124

## 4. System components

### 4.2.1 EX3DV3 Probe Specification

#### Construction:

Symmetrical design with triangular core  
Built-in shielding against static charges  
PEEK enclosure material (resistant to organic solvents, e.g., glycol ether)

#### Calibration(S/N 3507):

Basic Broad Band Calibration in air : 10-3000 MHz  
Conversion Factors(Head and Body): 450MHz,900 MHz,1810MHz,2450MHz,  
5.2GHz,5.5GHz,5.8GHz

#### Frequency:

10 MHz to > 6GHz; Linearity: +/-0.2 dB(30 MHz to 3 GHz)

#### Directivity:

+/-0.3 dB in HSL (rotation around probe axis)  
+/-0.5 dB in tissue material (rotation normal probe axis)

#### Dynamic Range:

10uW/g to > 100 mW/g;Linearity: +/-0.2 dB(noise: typically < 1uW/g)

#### Dimensions:

Overall length: 330 mm (Tip: 20 mm)  
Tip diameter: 2.5mm (Body: 12 mm)  
Typical distance from probe tip to dipole centers: 1 mm

#### Application:

Highprecision dosimetric measurement in any exposure scenario  
(e.g., very strong gradient fields).Only probe which enables compliance  
testing for frequencies up to 6GHz with precision of better 30%.



**EX3DV3 E-field Probe**

---

**UL Japan, Inc.**

**Head Office EMC Lab.**

4383-326 Asama-cho, Ise-shi, Mie-ken 516-0021 JAPAN

Telephone : +81 596 24 8116

Facsimile : +81 596 24 8124

## 2mm Flat phantom

### Construction:

2mm Flat phantom V4.3L enables the dosimetric evaluation of body mounted.

A cover prevents evaporatuin of the liquid.

Reference markings on the phantom allow the complete setup of all predefined phantom position and measurement grids by manually teaching three points with the robot.

### Shell Thickness:

Central region : 2 +/-0.2mm

Circumference region : 6 +/-0.2mm

### Dimensions:

Inside (H x L x W) : 180 x 800 x 420 mm

Central region (L x W) : 650 x 250mm



2mm Flat phantom V4.3L

### Device Holder

For this measurement, the urethane foam was used as device holder.

---

## UL Japan, Inc.

### Head Office EMC Lab.

4383-326 Asama-cho, Ise-shi, Mie-ken 516-0021 JAPAN

Telephone : +81 596 24 8116

Facsimile : +81 596 24 8124

## 5. Test system specifications

### Robot RX60L

Number of Axes	:	6
Payload	:	1.6 kg
Reach	:	800mm
Repeatability	:	+/-0.025mm
Control Unit	:	CS7M
Programming Language	:	V+
Manufacture	:	Stäubli Unimation Corp. Robot Model: RX60

### DASY4 Measurement server

Features	:	166MHz low power Pentium MMX 32MB chipdisk and 64MB RAM Serial link to DAE (with watchdog supervision) 16 Bit A/D converter for surface detection system Two serial links to robot (one for real-time communication which is supervised by watchdog) Ethernet link to PC (with watchdog supervision) Emergency stop relay for robot safety chainTwo expansion slots for future applications
Manufacture	:	Schimid & Partner Engineering AG

### Data Acquisition Electronic (DAE)

Features	:	Signal amplifier, multiplexer, A/D converter and control logic Serial optical link for communication with DASY4 embedded system (fully remote controlled) 2 step probe touch detector for mechanical surface detection and emergency robot stop (not in -R version)
Measurement Range	:	1 $\mu$ V to > 200 mV (16 bit resolution and two range settings: 4mV, 400mV)
Input Offset voltage	:	< 1 $\mu$ V (with auto zero)
Input Resistance	:	200 M $\Omega$
Battery Power	:	> 10 h of operation (with two 9 V battery)
Dimension	:	60 x 60 x 68 mm
Manufacture	:	Schimid & Partner Engineering AG

### Software

Item	:	Dosimetric Assesment System DASY4
Type No.	:	SD 000 401A, SD 000 402A
Software version No.	:	4.6
Manufacture / Origin	:	Schimid & Partner Engineering AG

### E-Field Probe

Model	:	EX3DV4
Serial No.	:	3507
Construction	:	Symmetrical design with triangular core
Frequency	:	10 MHz to 6 GHz
Linearity	:	+/-0.2 dB (30 MHz to 3 GHz)
Manufacture	:	Schimid & Partner Engineering AG

---

## UL Japan, Inc.

### Head Office EMC Lab.

4383-326 Asama-cho, Ise-shi, Mie-ken 516-0021 JAPAN

Telephone : +81 596 24 8116

Facsimile : +81 596 24 8124

Test report No. : 27IE0024-HO-E-R1  
Page : 59 of 84  
Issued date : September 25, 2007  
Revised date : November 18, 2007  
FCC ID : D7LNT511

---

**Phantom**

Type : 2mm Flat phantom V4.3L  
Shell Material : Fiberglass  
Shell Thickness : Central region : 2 +/-0.2mm  
Circumference region : 6 +/-0.2mm  
Dimensions : Inside (H x L x W) : 180 x 800 x 420 mm  
Central region (L x W) : 650 x 250mm  
Manufacture : Schimid & Partner Engineering AG

---

**UL Japan, Inc.**

**Head Office EMC Lab.**

4383-326 Asama-cho, Ise-shi, Mie-ken 516-0021 JAPAN

Telephone : +81 596 24 8116

Facsimile : +81 596 24 8124



**6. Simulated Tissues Composition**

**6-a 2450MHz**

Ingredient	Mixture(%)
	Muscle 2450MHz
Water	69.83
DGMBE	30.2

Note:DGMBE(Diethylenglycol-monobuthyl ether)

**7. Simulated Tissue Liquid Parameter confirmation**

**7-a Body 2450 MHz**

Type of liquid : Muscle 2450 MHz  
Ambient temperature (deg.c.) : 25.0(Sep-10, 11)  
Relative Humidity (%) : 45(Sep-10), 48(Sep-11)  
Liquid depth (cm) : 15.0

DIELECTRIC PARAMETERS MEASUREMENT RESULTS								
Date	Frequency	Liquid Temp [deg.c]		Parameters	Target Value	Measured	Deviation [%]	Limit [%]
		Before	After					
10-Sep	2450	24.1	24.1	Relative Permittivity $\epsilon_r$	52.7 *1	51.4	-2.5	+/-5
				Coconductivity $\sigma$ [mho/m]	1.95 *1	2.01	3.1	+/-5
10-Sep	2450	24.1	24.1	Relative Permittivity $\epsilon_r$	52.2 *2	51.4	-1.5	+/-5
				Coconductivity $\sigma$ [mho/m]	1.99 *2	2.01	1.0	+/-5
11-Sep	2450	24.2	24.2	Relative Permittivity $\epsilon_r$	52.7 *1	50.2	-4.7	+/-5
				Coconductivity $\sigma$ [mho/m]	1.95 *1	1.95	0.0	+/-5
11-Sep	2450	24.2	24.2	Relative Permittivity $\epsilon_r$	52.2 *2	50.2	-3.8	+/-5
				Coconductivity $\sigma$ [mho/m]	1.99 *2	1.95	-2.0	+/-5

\*1 The target values is a parameter defined in FCC OET 65.

\*2 The target value is the calibrated dipole TSL parameters. (D2450V2,S/N: 713)

**UL Japan, Inc.**

**Head Office EMC Lab.**

4383-326 Asama-cho, Ise-shi, Mie-ken 516-0021 JAPAN

Telephone : +81 596 24 8116

Facsimile : +81 596 24 8124

## 8. System validation data

Prior to the assessment, the system validation kit was used to test whether the system was operating within its specifications of +/-10%. The validation results are in the table below. Please refer to “10. Validation measurement data”.

We performed the system validation based on FCC requirement, [The 1-g or 10-g SAR values measured using the required tissue dielectric parameters should be within 10% of manufacturer calibrated dipole SAR values. However these manufacturer calibrated dipole target SAR values should be substantially similar to those defined in IEEE Standard 1528. ] and FCC permits [SAR system verification with the actual liquid used for DUT SAR measurement should be the default operating procedures.]

We confirmed the this dipole manufacture's validation date for head is within 5% against IEEE Standard 1528. so we can only use Body liquid validation data for our system verification.

---

**UL Japan, Inc.**

**Head Office EMC Lab.**

4383-326 Asama-cho, Ise-shi, Mie-ken 516-0021 JAPAN

Telephone : +81 596 24 8116

Facsimile : +81 596 24 8124

**System validation of 2450MHz**

Type of liquid : Muscle 2450 MHz  
Ambient temperature (deg.c.) : 25.0(Sep-10, 11)  
Relative Humidity (%) : 45(Sep-10), 48(Sep-11)  
Dipole : D2450V2 SN:713  
Power : 250mW

SYSTEM PERFORMANCE CHECK									
Date	Liquid (Muscle 2450MHz)						measured		
	Liquid Temp [deg.c.]		Relative Permittivity $\epsilon_r$		Conductivity $\sigma$ [mho/m]		SAR 1g [W/kg]		Deviation [%]
	Before	After	Target	Measured	Target	Measured	Target	Measured	
10-Sep	24.2	24.2	52.7	51.4	1.95	2.01	13.1 *1	13.4	2.3
10-Sep	24.2	24.2	52.2	51.4	1.99	2.01	13.7 *2	13.4	-2.2
11-Sep	24.0	24.0	52.7	50.2	1.95	1.95	13.1 *1	13.0	-0.8
11-Sep	24.0	24.0	52.2	50.2	1.99	1.95	13.7 *2	13.0	-5.1

\*1 The target value is a 1g SAR value defined in IEEE Standard 1528.

\*2 The target value is a manufacturer calibrated dipole 1g SAR value.

Note: Please refer to Attachment for the result representation in plot format

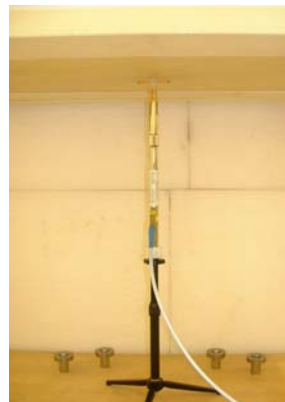
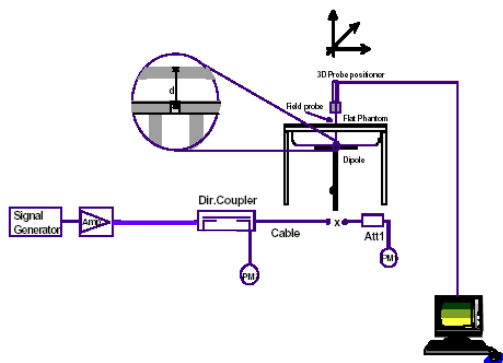

2450MHz System performance check setup

**Test system for the system performance check setup diagram**

### 9. Validation uncertainty

The uncertainty budget has been determined for the DASY4 measurement system according to the SPEAG documents[6][7] and is given in the following Table.

Error Description	Uncertainty value $\pm$ %	Probability distribution	divisor	(ci) 10g	Standard Uncertainty (10g)	vi or veff
<b>Measurement System</b>						
Probe Calibration	$\pm 6.8$	Normal	1	1	$\pm 6.8$	$\infty$
Probe isotropy	$\pm 7.6$	Rectangular	$\sqrt{3}$	1	$\pm 4.4$	$\infty$
Probe linearity	$\pm 4.7$	Rectangular	$\sqrt{3}$	1	$\pm 2.7$	$\infty$
Detection Limit	$\pm 1.0$	Rectangular	$\sqrt{3}$	1	$\pm 0.6$	$\infty$
Boundary effects	$\pm 2.0$	Rectangular	$\sqrt{3}$	1	$\pm 1.2$	$\infty$
Measurement device	$\pm 0.3$	Normal	1	1	$\pm 0.3$	$\infty$
Response time	$\pm 0$	Normal	1	1	$\pm 0$	$\infty$
Noise	$\pm 3.0$	Normal	1	1	$\pm 3.0$	$\infty$
Integration time	$\pm 0$	Normal	1	1	$\pm 0$	$\infty$
<b>Mechanical Constraints</b>						
Scanning system	$\pm 0.8$	Rectangular	$\sqrt{3}$	1	$\pm 0.5$	$\infty$
Phantom shell	$\pm 4.0$	Rectangular	$\sqrt{3}$	1	$\pm 2.3$	$\infty$
Matching between probe and phantom	$\pm 9.9$	Rectangular	$\sqrt{3}$	1	$\pm 5.7$	$\infty$
<b>Dipole</b>						
Dipole Axis to Liquid Distance	$\pm 2.0$	Rectangular	$\sqrt{3}$	1	$\pm 1.2$	$\infty$
Input power and SAR drift meas.	$\pm 4.7$	Rectangular	$\sqrt{3}$	1	$\pm 2.7$	$\infty$
<b>Phantom and Setup</b>						
Liquid Conductivity (Target)	$\pm 5.0$	Rectangular	$\sqrt{3}$	0.5	$\pm 1.4$	$\infty$
Liquid Conductivity (meas.)	$\pm 5.0$	Rectangular	$\sqrt{3}$	0.5	$\pm 1.4$	$\infty$
Liquid permittivity (Target)	$\pm 5.0$	Rectangular	$\sqrt{3}$	0.5	$\pm 1.4$	$\infty$
Liquid permittivity (meas.)	$\pm 5.0$	Rectangular	$\sqrt{3}$	0.5	$\pm 1.4$	$\infty$
perturbation by thr enviromrent	$\pm 3.0$	Normal	1	1	$\pm 3.0$	$\infty$
<b>Post-processing</b>						
Extrapolation, Interpolation and Integration Algorithms for Max.SAR Evalition	$\pm 4.0$	Rectangular	$\sqrt{3}$	1	$\pm 2.3$	$\infty$
<b>Combined Standard Uncertainty</b>					<b><math>\pm 12.36</math></b>	
<b>Expanded Uncertainty (k=2)</b>					<b><math>\pm 24.71</math></b>	

**UL Japan, Inc.**

**Head Office EMC Lab.**

4383-326 Asama-cho, Ise-shi, Mie-ken 516-0021 JAPAN

Telephone : +81 596 24 8116

Facsimile : +81 596 24 8124

## 10. Validation measurement data

### 2450MHz System Validation / Dipole2450MHz / Forward Conducted Power : 250mW

#### Dipole 2450 MHz; Type: D2450V2; Serial: 713

Communication System: CW; Frequency: 2450 MHz; Crest factor: 1

Medium: M2450 Medium parameters used:  $f = 2450$  MHz;  $\sigma = 1.95$  mho/m;  $\epsilon_r = 50.2$ ;  $\rho = 1000$  kg/m<sup>3</sup>

Phantom section: Flat Section

DASY4 Configuration:

- Probe: EX3DV3 - SN3507; ConvF(8, 8, 8); Calibrated: 2007/06/15

- Sensor-Surface: 2mm (Mechanical Surface Detection)

- Phantom: Flat Phantom 4.3

- Measurement SW: DASY4, V4.6 Build 23; Postprocessing SW: SEMCAD, V1.8 Build 160

**Area Scan (51x51x1):** Measurement grid: dx=15mm, dy=15mm

Maximum value of SAR (interpolated) = 20.6 mW/g

**Zoom Scan (7x7x7)/Cube 0:** Measurement grid: dx=5mm, dy=5mm, dz=5mm

Reference Value = 100.0 V/m; Power Drift = -0.002 dB

Peak SAR (extrapolated) = 23.2 W/kg

**SAR(1 g) = 13.4 mW/g; SAR(10 g) = 6.11 mW/g**

Maximum value of SAR (measured) = 20.8 mW/g

Test Date = 09/10/07

Ambient Temperature = 25.0 degree.c

Liquid Temperature = Before 24.2 degree.C , After 24.2 degree.C

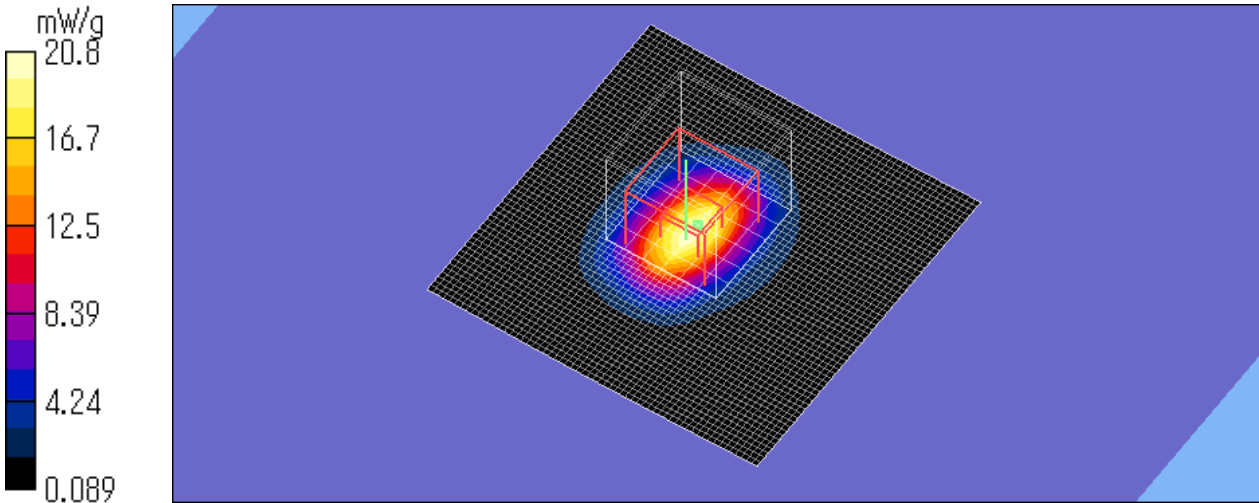

**UL Japan, Inc.**

**Head Office EMC Lab.**

4383-326 Asama-cho, Ise-shi, Mie-ken 516-0021 JAPAN

Telephone : +81 596 24 8116

Facsimile : +81 596 24 8124

**2450MHz System Validation / Dipole2450MHz / Forward Conducted Power : 250mW**

**Dipole 2450 MHz; Type: D2450V2; Serial: 713**

Communication System: CW; Frequency: 2450 MHz; Crest factor: 1  
Medium: M2450 Medium parameters used:  $f = 2450$  MHz;  $\sigma = 1.95$  mho/m;  $\epsilon_r = 50.2$ ;  $\rho = 1000$  kg/m<sup>3</sup>  
Phantom section: Flat Section  
DASY4 Configuration:  
- Probe: EX3DV3 - SN3507; ConvF(8, 8, 8); Calibrated: 2007/06/15  
- Sensor-Surface: 2mm (Mechanical Surface Detection)  
- Phantom: Flat Phantom 4.3  
- Measurement SW: DASY4, V4.6 Build 23; Postprocessing SW: SEMCAD, V1.8 Build 160

**Area Scan (51x51x1):** Measurement grid: dx=15mm, dy=15mm  
Maximum value of SAR (interpolated) = 20.9 mW/g

**Zoom Scan (7x7x7)/Cube 0:** Measurement grid: dx=5mm, dy=5mm, dz=5mm  
Reference Value = 100.0 V/m; Power Drift = -0.004 dB  
Peak SAR (extrapolated) = 23.2 W/kg

**SAR(1 g) = 13.0 mW/g; SAR(10 g) = 6.10 mW/g**  
Maximum value of SAR (measured) = 20.2 mW/g

Test Date = 09/11/07  
Ambient Temperature = 25.0 degree.c  
Liquid Temperature = Before 24.0 degree.C , After 24.0 degree.C

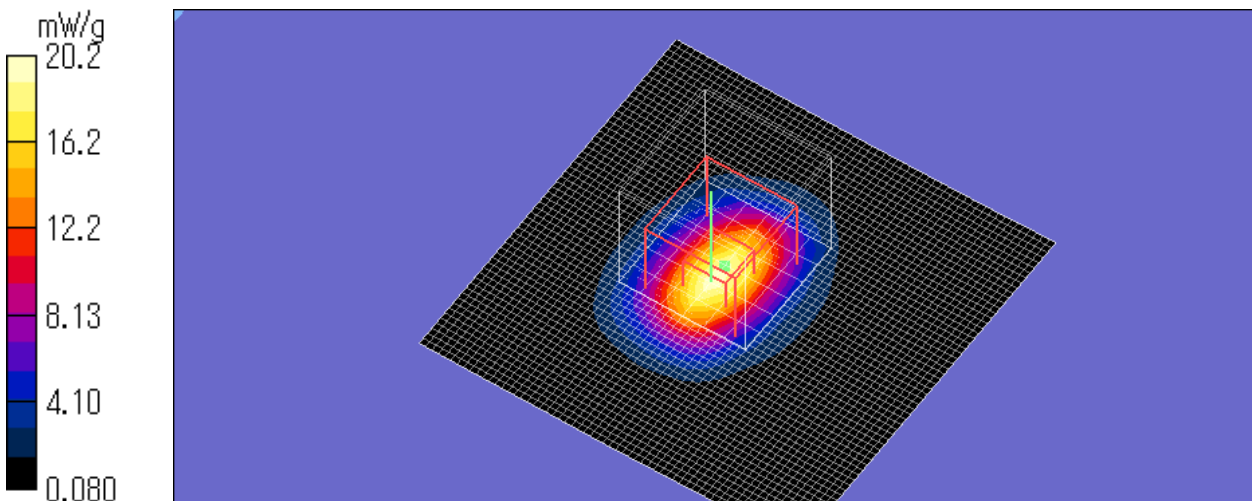

11. System Validation Dipole (D2450V2,S/N: 713)

**Calibration Laboratory of**  
**Schmid & Partner**  
**Engineering AG**  
 Zeughausstrasse 43, 8004 Zurich, Switzerland



**S** Schweizerischer Kalibrierdienst  
**C** Service suisse d'étalonnage  
**S** Servizio svizzero di taratura  
**S** Swiss Calibration Service

Accredited by the Swiss Federal Office of Metrology and Accreditation  
 The Swiss Accreditation Service is one of the signatories to the EA  
 Multilateral Agreement for the recognition of calibration certificates

Accreditation No.: **SCS 108**

Client **ULA-pex (MTT)**

Certificate No: **D2450V2-713\_Sep06**

**CALIBRATION CERTIFICATE**

Object: **D2450V2 - SN: 713**

Calibration procedure(s): **QA CAL-05.v6  
 Calibration procedure for dipole validation kits**

Calibration date: **September 27, 2006**

Condition of the calibrated item: **In Tolerance**

This calibration certificate documents the traceability to national standards, which realize the physical units of measurements (SI).  
 The measurements and the uncertainties with confidence probability are given on the following pages and are part of the certificate.

All calibrations have been conducted in the closed laboratory facility: environment temperature (22 ± 3)°C and humidity < 70%.

Calibration Equipment used (M&TE critical for calibration)

Primary Standards	ID #	Cal Date (Calibrated by, Certificate No.)	Scheduled Calibration
Power meter EPM-442A	GB37480704	04-Oct-05 (METAS, No. 251-00516)	Oct-06
Power sensor HP 8481A	US37292783	04-Oct-05 (METAS, No. 251-00516)	Oct-06
Reference 20 dB Attenuator	SN: 5086 (20g)	10-Aug-06 (METAS, No 217-00591)	Aug-07
Reference 10 dB Attenuator	SN: 5047.2 (10r)	10-Aug-06 (METAS, No 217-00591)	Aug-07
Reference Probe ES3DV2	SN 3025	28-Oct-05 (SPEAG, No. ES3-3025_Oct05)	Oct-06
DAE4	SN 601	15-Dec-05 (SPEAG, No. DAE4-601_Dec05)	Dec-06
Secondary Standards	ID #	Check Date (In house)	Scheduled Check
Power sensor HP 8481A	MY41092317	18-Oct-02 (SPEAG, in house check Oct-05)	In house check: Oct-07
RF generator Agilent E4421B	MY41000675	11-May-05 (SPEAG, in house check Nov-05)	In house check: Nov-07
Network Analyzer HP 8753E	US37390585 S4206	18-Oct-01 (SPEAG, in house check Nov-05)	In house check: Nov-06

	Name	Function	Signature
Calibrated by:	Claudio Leubler	Laboratory Technician	
Approved by:	Katja Pokovic	Technical Manager	

Issued: September 28, 2006

This calibration certificate shall not be reproduced except in full without written approval of the laboratory.

**Calibration Laboratory of  
Schmid & Partner  
Engineering AG**  
Zeughausstrasse 43, 8004 Zurich, Switzerland



**S** Schweizerischer Kalibrierdienst  
**C** Service suisse d'étalonnage  
**S** Servizio svizzero di taratura  
**S** Swiss Calibration Service

Accredited by the Swiss Federal Office of Metrology and Accreditation  
The Swiss Accreditation Service is one of the signatories to the EA  
Multilateral Agreement for the recognition of calibration certificates

Accreditation No.: **SCS 108**

**Glossary:**

TSL tissue simulating liquid  
ConvF sensitivity in TSL / NORM x,y,z  
N/A not applicable or not measured

**Calibration is Performed According to the Following Standards:**

- a) IEEE Std 1528-2003, "IEEE Recommended Practice for Determining the Peak Spatial-Averaged Specific Absorption Rate (SAR) in the Human Head from Wireless Communications Devices: Measurement Techniques", December 2003
- b) CENELEC EN 50361, "Basic standard for the measurement of Specific Absorption Rate related to human exposure to electromagnetic fields from mobile phones (300 MHz - 3 GHz), July 2001
- c) Federal Communications Commission Office of Engineering & Technology (FCC OET), "Evaluating Compliance with FCC Guidelines for Human Exposure to Radiofrequency Electromagnetic Fields; Additional Information for Evaluating Compliance of Mobile and Portable Devices with FCC Limits for Human Exposure to Radiofrequency Emissions", Supplement C (Edition 01-01) to Bulletin 65

**Additional Documentation:**

- d) DASY4 System Handbook

**Methods Applied and Interpretation of Parameters:**

- *Measurement Conditions:* Further details are available from the Validation Report at the end of the certificate. All figures stated in the certificate are valid at the frequency indicated.
- *Antenna Parameters with TSL:* The dipole is mounted with the spacer to position its feed point exactly below the center marking of the flat phantom section, with the arms oriented parallel to the body axis.
- *Feed Point Impedance and Return Loss:* These parameters are measured with the dipole positioned under the liquid filled phantom. The impedance stated is transformed from the measurement at the SMA connector to the feed point. The Return Loss ensures low reflected power. No uncertainty required.
- *Electrical Delay:* One-way delay between the SMA connector and the antenna feed point. No uncertainty required.
- *SAR measured:* SAR measured at the stated antenna input power.
- *SAR normalized:* SAR as measured, normalized to an input power of 1 W at the antenna connector.
- *SAR for nominal TSL parameters:* The measured TSL parameters are used to calculate the nominal SAR result.

**UL Japan, Inc.**

**Head Office EMC Lab.**

4383-326 Asama-cho, Ise-shi, Mie-ken 516-0021 JAPAN

Telephone : +81 596 24 8116

Facsimile : +81 596 24 8124



### Measurement Conditions

DASY system configuration, as far as not given on page 1.

DASY Version	DASY4	V4.7
Extrapolation	Advanced Extrapolation	
Phantom	Modular Flat Phantom V5.0	
Distance Dipole Center - TSL	10 mm	with Spacer
Zoom Scan Resolution	dx, dy, dz = 5 mm	
Frequency	2450 MHz ± 1 MHz	

### Head TSL parameters

The following parameters and calculations were applied.

	Temperature	Permittivity	Conductivity
Nominal Head TSL parameters	22.0 °C	39.2	1.80 mho/m
Measured Head TSL parameters	(22.0 ± 0.2) °C	37.8 ± 6 %	1.77 mho/m ± 6 %
Head TSL temperature during test	(22.0 ± 0.2) °C	-----	-----

### SAR result with Head TSL

SAR averaged over 1 cm <sup>3</sup> (1 g) of Head TSL	condition	
SAR measured	250 mW input power	13.7 mW / g
SAR normalized	normalized to 1W	54.8 mW / g
SAR for nominal Head TSL parameters <sup>1</sup>	normalized to 1W	<b>54.2 mW / g ± 17.0 % (k=2)</b>

SAR averaged over 10 cm <sup>3</sup> (10 g) of Head TSL	condition	
SAR measured	250 mW input power	6.39 mW / g
SAR normalized	normalized to 1W	25.6 mW / g
SAR for nominal Head TSL parameters <sup>1</sup>	normalized to 1W	<b>25.3 mW / g ± 16.5 % (k=2)</b>

<sup>1</sup> Correction to nominal TSL parameters according to d), chapter "SAR Sensitivities"

**UL Japan, Inc.**

**Head Office EMC Lab.**

4383-326 Asama-cho, Ise-shi, Mie-ken 516-0021 JAPAN

Telephone : +81 596 24 8116

Facsimile : +81 596 24 8124

**Body TSL parameters**

The following parameters and calculations were applied.

	Temperature	Permittivity	Conductivity
Nominal Body TSL parameters	22.0 °C	52.7	1.95 mho/m
Measured Body TSL parameters	(22.0 ± 0.2) °C	52.1 ± 6 %	1.97 mho/m ± 6 %
Body TSL temperature during test	(21.7 ± 0.2) °C	---	---

**SAR result with Body TSL**

SAR averaged over 1 cm <sup>3</sup> (1 g) of Body TSL	Condition	
SAR measured	250 mW input power	13.7 mW / g
SAR normalized	normalized to 1W	54.8 mW / g
SAR for nominal Body TSL parameters <sup>2</sup>	normalized to 1W	<b>54.1 mW / g ± 17.0 % (k=2)</b>

SAR averaged over 10 cm <sup>3</sup> (10 g) of Body TSL	Condition	
SAR measured	250 mW input power	6.34 mW / g
SAR normalized	normalized to 1W	25.4 mW / g
SAR for nominal Body TSL parameters <sup>2</sup>	normalized to 1W	<b>25.2 mW / g ± 16.5 % (k=2)</b>

<sup>2</sup> Correction to nominal TSL parameters according to d), chapter "SAR Sensitivities"

**UL Japan, Inc.**

**Head Office EMC Lab.**

4383-326 Asama-cho, Ise-shi, Mie-ken 516-0021 JAPAN

Telephone : +81 596 24 8116

Facsimile : +81 596 24 8124

## Appendix

### Antenna Parameters with Head TSL

Impedance, transformed to feed point	51.2 $\Omega$ + 3.3 j $\Omega$
Return Loss	- 29.3 dB

### Antenna Parameters with Body TSL

Impedance, transformed to feed point	47.7 $\Omega$ + 4.0 j $\Omega$
Return Loss	- 26.5 dB

### General Antenna Parameters and Design

Electrical Delay (one direction)	1.160 ns
----------------------------------	----------

After long term use with 100W radiated power, only a slight warming of the dipole near the feedpoint can be measured.

The dipole is made of standard semirigid coaxial cable. The center conductor of the feeding line is directly connected to the second arm of the dipole. The antenna is therefore short-circuited for DC-signals.

No excessive force must be applied to the dipole arms, because they might bend or the soldered connections near the feedpoint may be damaged.

### Additional EUT Data

Manufactured by	SPEAG
Manufactured on	July 5, 2002

**UL Japan, Inc.**

**Head Office EMC Lab.**

4383-326 Asama-cho, Ise-shi, Mie-ken 516-0021 JAPAN

Telephone : +81 596 24 8116

Facsimile : +81 596 24 8124

## DASY4 Validation Report for Head TSL

Date/Time: 27.09.2006 11:36:11

Test Laboratory: SPEAG, Zurich, Switzerland

**DUT: Dipole 2450 MHz; Type: D2450V2; Serial: D2450V2 – SN713**

Communication System: CW-2450; Frequency: 2450 MHz; Duty Cycle: 1:1

Medium: HSL U10 BB

Medium parameters used:  $f = 2450$  MHz;  $\sigma = 1.77$  mho/m;  $\epsilon_r = 37.8$ ;  $\rho = 1000$  kg/m<sup>3</sup>

Phantom section: Flat Section

Measurement Standard: DASY4 (High Precision Assessment)

DASY4 Configuration:

- Probe: ES3DV2 - SN3025 (HF); ConvF(4.4, 4.4, 4.4); Calibrated: 28.10.2005
- Sensor-Surface: 4mm (Mechanical Surface Detection)
- Electronics: DAE4 Sn601; Calibrated: 15.12.2005
- Phantom: Flat Phantom 5.0 (front); Type: QD000P50AA; ;
- Measurement SW: DASY4, V4.7 Build 44; Postprocessing SW: SEMCAD, V1.8 Build 171

**Pin = 250 mW; d = 10 mm/Zoom Scan (7x7x7)/Cube 0:**

Measurement grid: dx=5mm, dy=5mm, dz=5mm

Reference Value = 91.5 V/m; Power Drift = 0.078 dB

Peak SAR (extrapolated) = 28.5 W/kg

**SAR(1 g) = 13.7 mW/g; SAR(10 g) = 6.39 mW/g**

Maximum value of SAR (measured) = 15.0 mW/g

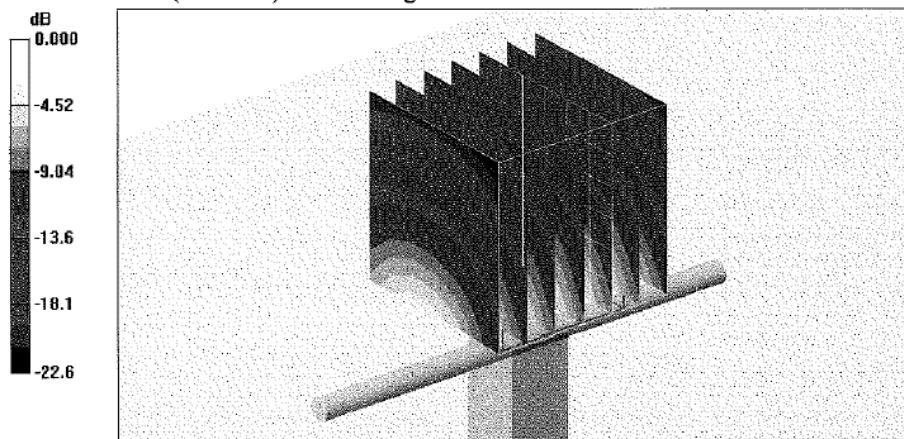

**UL Japan, Inc.**

**Head Office EMC Lab.**

4383-326 Asama-cho, Ise-shi, Mie-ken 516-0021 JAPAN

Telephone : +81 596 24 8116

Facsimile : +81 596 24 8124

**Impedance Measurement Plot for Head TSL**

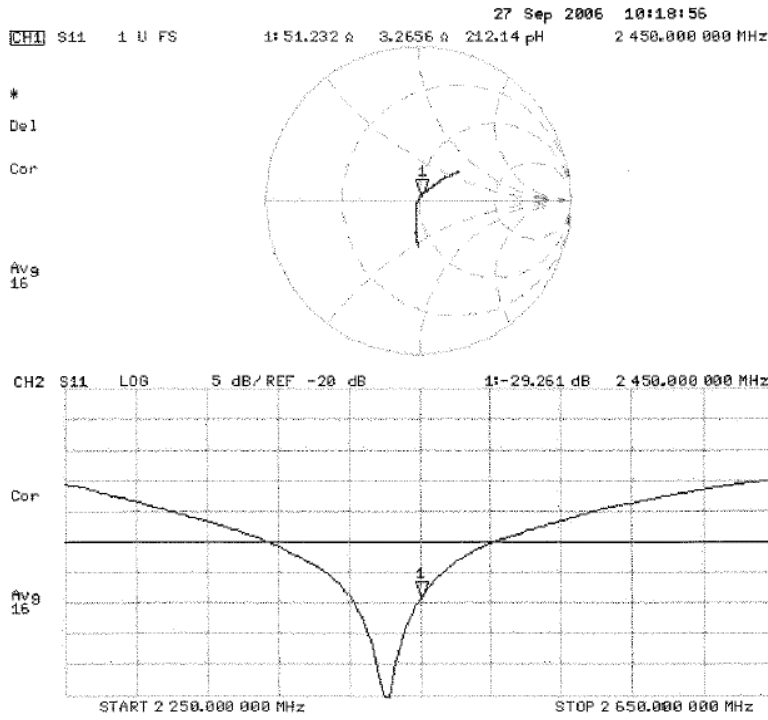

**DASY4 Validation Report for Body TSL**

Date/Time: 27.09.2006 14:23:31

Test Laboratory: SPEAG, Zurich, Switzerland

**DUT: Dipole 2450 MHz; Type: D2450V2; Serial: D2450V2 – SN713**

Communication System: CW-2450; Frequency: 2450 MHz; Duty Cycle: 1:1

Medium: MSL U10 BB;

Medium parameters used:  $f = 2450$  MHz;  $\sigma = 1.97$  mho/m;  $\epsilon_r = 52.2$ ;  $\rho = 1000$  kg/m<sup>3</sup>

Phantom section: Flat Section

Measurement Standard: DASY4 (High Precision Assessment)

DASY4 Configuration:

- Probe: ES3DV2 - SN3025 (HF); ConvF(4.06, 4.06, 4.06); Calibrated: 28.10.2005
- Sensor-Surface: 4mm (Mechanical Surface Detection)
- Electronics: DAE4 Sn601; Calibrated: 15.12.2005
- Phantom: Flat Phantom 5.0 (back); Type: QD000P50AA; ;
- Measurement SW: DASY4, V4.7 Build 44; Postprocessing SW: SEMCAD, V1.8 Build 171

**Pin = 250 mW; d = 10 mm/Zoom Scan (7x7x7)/Cube 0:**

Measurement grid: dx=5mm, dy=5mm, dz=5mm

Reference Value = 89.4 V/m; Power Drift = -0.054 dB

Peak SAR (extrapolated) = 28.5 W/kg

**SAR(1 g) = 13.7 mW/g; SAR(10 g) = 6.34 mW/g**

Maximum value of SAR (measured) = 15.4 mW/g

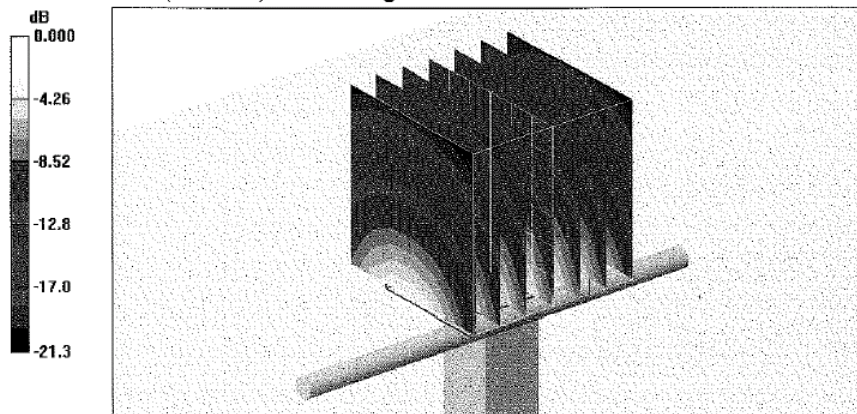

0 dB = 15.4mW/g

**UL Japan, Inc.**

**Head Office EMC Lab.**

4383-326 Asama-cho, Ise-shi, Mie-ken 516-0021 JAPAN

Telephone : +81 596 24 8116

Facsimile : +81 596 24 8124

**Impedance Measurement Plot for Body TSL**

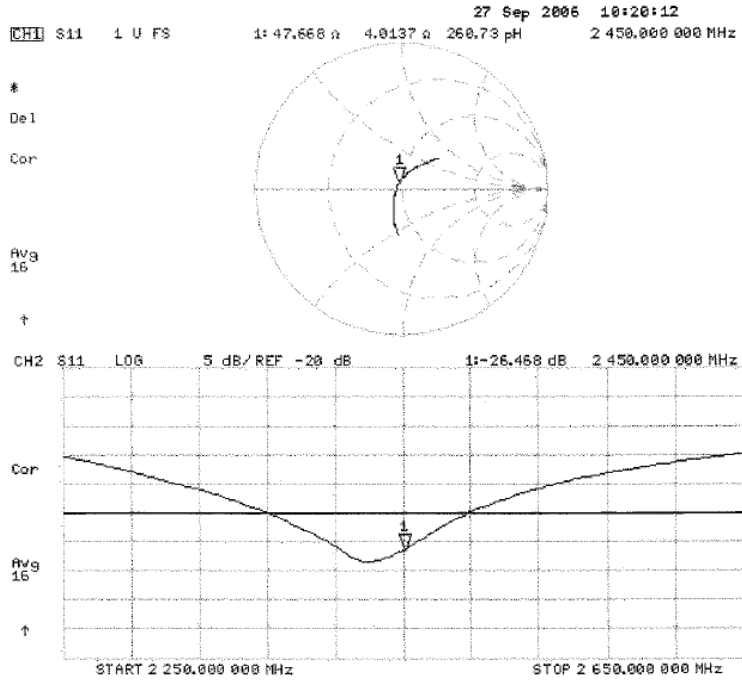

Test report No. : 27IE0024-HO-E-R1  
 Page : 75 of 84  
 Issued date : September 25, 2007  
 Revised date : November 18, 2007  
 FCC ID : D7LJNT511

12. Dosimetric E-Field Probe Calibration (EX3DV3,S/N: 3507)

Calibration Laboratory of  
 Schmid & Partner  
 Engineering AG  
 Zeughausstrasse 43, 8004 Zurich, Switzerland



S Schweizerischer Kalibrierdienst  
 C Service suisse d'étalonnage  
 S Servizio svizzero di taratura  
 S Swiss Calibration Service

Accredited by the Swiss Federal Office of Metrology and Accreditation  
 The Swiss Accreditation Service is one of the signatories to the EA  
 Multilateral Agreement for the recognition of calibration certificates

Accreditation No.: SCS 108

Client **UL Japan (MTT)**

Certificate No: **EX3-3507\_Jun07**

CALIBRATION CERTIFICATE			
Object	EX3DV3 - SN:3507		
Calibration procedure(s)	QA CAL-01.v6 and QA CAL-14.v3 Calibration procedure for dosimetric E-field probes		
Calibration date:	June 15, 2007		
Condition of the calibrated item	In Tolerance		
<p>This calibration certificate documents the traceability to national standards, which realize the physical units of measurements (SI).            The measurements and the uncertainties with confidence probability are given on the following pages and are part of the certificate.</p> <p>All calibrations have been conducted in the closed laboratory facility: environment temperature (22 ± 3)°C and humidity &lt; 70%.</p> <p>Calibration Equipment used (M&amp;TE critical for calibration)</p>			
Primary Standards	ID #	Cal Date (Calibrated by, Certificate No.)	Scheduled Calibration
Power meter E4419B	GB41293874	29-Mar-07 (METAS, No. 217-00670)	Mar-08
Power sensor E4412A	MY41495277	29-Mar-07 (METAS, No. 217-00670)	Mar-08
Power sensor E4412A	MY41498087	29-Mar-07 (METAS, No. 217-00670)	Mar-08
Reference 3 dB Attenuator	SN: S5054 (3c)	10-Aug-06 (METAS, No. 217-00592)	Aug-07
Reference 20 dB Attenuator	SN: S5086 (20b)	29-Mar-07 (METAS, No. 217-00671)	Mar-08
Reference 30 dB Attenuator	SN: S5129 (30b)	10-Aug-06 (METAS, No. 217-00593)	Aug-07
Reference Probe ES3DV2	SN: 3013	4-Jan-07 (SPEAG, No. ES3-3013_Jan07)	Jan-08
DAE4	SN: 654	20-Apr-07 (SPEAG, No. DAE4-654_Apr07)	Apr-08
Secondary Standards	ID #	Check Date (in house)	Scheduled Check
RF generator HP 8648C	US3642U01700	4-Aug-99 (SPEAG, in house check Nov-05)	In house check: Nov-07
Network Analyzer HP 8753E	US37390585	18-Oct-01 (SPEAG, in house check Oct-06)	In house check: Oct-07
Calibrated by:	Name Katja Pokovic	Function Technical Manager	Signature 
Approved by:	Fin Bornholt	R&D Director	
Issued: June 15, 2007			
This calibration certificate shall not be reproduced except in full without written approval of the laboratory.			

Certificate No: EX3-3507\_Jun07

Page 1 of 9

**UL Japan, Inc.**  
**Head Office EMC Lab.**  
 4383-326 Asama-cho, Ise-shi, Mie-ken 516-0021 JAPAN  
 Telephone : +81 596 24 8116  
 Facsimile : +81 596 24 8124



Calibration Laboratory of  
Schmid & Partner  
Engineering AG  
Zeughausstrasse 43, 8004 Zurich, Switzerland



S Schweizerischer Kalibrierdienst  
C Service suisse d'étalonnage  
S Servizio svizzero di taratura  
S Swiss Calibration Service

Accredited by the Swiss Federal Office of Metrology and Accreditation  
The Swiss Accreditation Service is one of the signatories to the EA  
Multilateral Agreement for the recognition of calibration certificates

Accreditation No.: SCS 108

#### Glossary:

TSL	tissue simulating liquid
NORM <sub>x,y,z</sub>	sensitivity in free space
ConF	sensitivity in TSL / NORM <sub>x,y,z</sub>
DCP	diode compression point
Polarization $\phi$	$\phi$ rotation around probe axis
Polarization $\vartheta$	$\vartheta$ rotation around an axis that is in the plane normal to probe axis (at measurement center), i.e., $\vartheta = 0$ is normal to probe axis

#### Calibration is Performed According to the Following Standards:

- IEEE Std 1528-2003, "IEEE Recommended Practice for Determining the Peak Spatial-Averaged Specific Absorption Rate (SAR) in the Human Head from Wireless Communications Devices: Measurement Techniques", December 2003
- IEC 62209-1, "Procedure to measure the Specific Absorption Rate (SAR) for hand-held devices used in close proximity to the ear (frequency range of 300 MHz to 3 GHz)", February 2005

#### Methods Applied and Interpretation of Parameters:

- NORM<sub>x,y,z</sub>**: Assessed for E-field polarization  $\vartheta = 0$  ( $f \leq 900$  MHz in TEM-cell;  $f > 1800$  MHz: R22 waveguide). NORM<sub>x,y,z</sub> are only intermediate values, i.e., the uncertainties of NORM<sub>x,y,z</sub> does not effect the E<sup>2</sup>-field uncertainty inside TSL (see below *ConvF*).
- NORM(f)<sub>x,y,z</sub> = NORM<sub>x,y,z</sub> \* frequency\_response** (see Frequency Response Chart). This linearization is implemented in DASY4 software versions later than 4.2. The uncertainty of the frequency response is included in the stated uncertainty of *ConvF*.
- DCP<sub>x,y,z</sub>**: DCP are numerical linearization parameters assessed based on the data of power sweep (no uncertainty required). DCP does not depend on frequency nor media.
- ConvF and Boundary Effect Parameters**: Assessed in flat phantom using E-field (or Temperature Transfer Standard for  $f \leq 800$  MHz) and inside waveguide using analytical field distributions based on power measurements for  $f > 800$  MHz. The same setups are used for assessment of the parameters applied for boundary compensation (alpha, depth) of which typical uncertainty values are given. These parameters are used in DASY4 software to improve probe accuracy close to the boundary. The sensitivity in TSL corresponds to NORM<sub>x,y,z</sub> \* *ConvF* whereby the uncertainty corresponds to that given for *ConvF*. A frequency dependent *ConvF* is used in DASY version 4.4 and higher which allows extending the validity from  $\pm 50$  MHz to  $\pm 100$  MHz.
- Spherical Isotropy (3D deviation from isotropy)**: In a field of low gradients realized using a flat phantom exposed by a patch antenna.
- Sensor Offset**: The sensor offset corresponds to the offset of virtual measurement center from the probe tip (on probe axis). No tolerance required.

UL Japan, Inc.

Head Office EMC Lab.

4383-326 Asama-cho, Ise-shi, Mie-ken 516-0021 JAPAN

Telephone : +81 596 24 8116

Facsimile : +81 596 24 8124

EX3DV3 SN:3507

June 15, 2007

# Probe EX3DV3

## SN:3507

Manufactured: December 15, 2003  
Last calibrated: May 26, 2006  
Repaired: June 1, 2007  
Recalibrated: June 15, 2007

Calibrated for DASY Systems

(Note: non-compatible with DASY2 system!)

---

**UL Japan, Inc.**

**Head Office EMC Lab.**

4383-326 Asama-cho, Ise-shi, Mie-ken 516-0021 JAPAN

Telephone : +81 596 24 8116

Facsimile : +81 596 24 8124

EX3DV3 SN:3507

June 15, 2007

## DASY - Parameters of Probe: EX3DV3 SN:3507

Sensitivity in Free Space <sup>A</sup>			Diode Compression <sup>B</sup>	
NormX	0.750 ± 10.1%	$\mu\text{V}/(\text{V}/\text{m})^2$	DCP X	97 mV
NormY	0.710 ± 10.1%	$\mu\text{V}/(\text{V}/\text{m})^2$	DCP Y	94 mV
NormZ	0.700 ± 10.1%	$\mu\text{V}/(\text{V}/\text{m})^2$	DCP Z	92 mV

### Sensitivity in Tissue Simulating Liquid (Conversion Factors)

Please see Page 8.

### Boundary Effect

<b>TSL</b>	<b>900 MHz</b>	<b>Typical SAR gradient: 5 % per mm</b>		
	Sensor Center to Phantom Surface Distance	<b>2.0 mm</b>	<b>3.0 mm</b>	
	SAR <sub>be</sub> [%] Without Correction Algorithm	3.8	1.6	
	SAR <sub>be</sub> [%] With Correction Algorithm	0.0	0.0	
<b>TSL</b>	<b>1810 MHz</b>	<b>Typical SAR gradient: 10 % per mm</b>		
	Sensor Center to Phantom Surface Distance	<b>2.0 mm</b>	<b>3.0 mm</b>	
	SAR <sub>be</sub> [%] Without Correction Algorithm	4.5	3.5	
	SAR <sub>be</sub> [%] With Correction Algorithm	0.2	0.4	

### Sensor Offset

Probe Tip to Sensor Center **1.0 mm**

The reported uncertainty of measurement is stated as the standard uncertainty of measurement multiplied by the coverage factor k=2, which for a normal distribution corresponds to a coverage probability of approximately 95%.

<sup>A</sup> The uncertainties of NormX,Y,Z do not affect the E<sup>2</sup>-field uncertainty inside TSL (see Page 6).

<sup>B</sup> Numerical linearization parameter; uncertainty not required.

**UL Japan, Inc.**

**Head Office EMC Lab.**

4383-326 Asama-cho, Ise-shi, Mie-ken 516-0021 JAPAN

Telephone : +81 596 24 8116

Facsimile : +81 596 24 8124

EX3DV3 SN:3507

June 15, 2007

### Frequency Response of E-Field

(TEM-Cell:ifi110 EXX, Waveguide: R22)

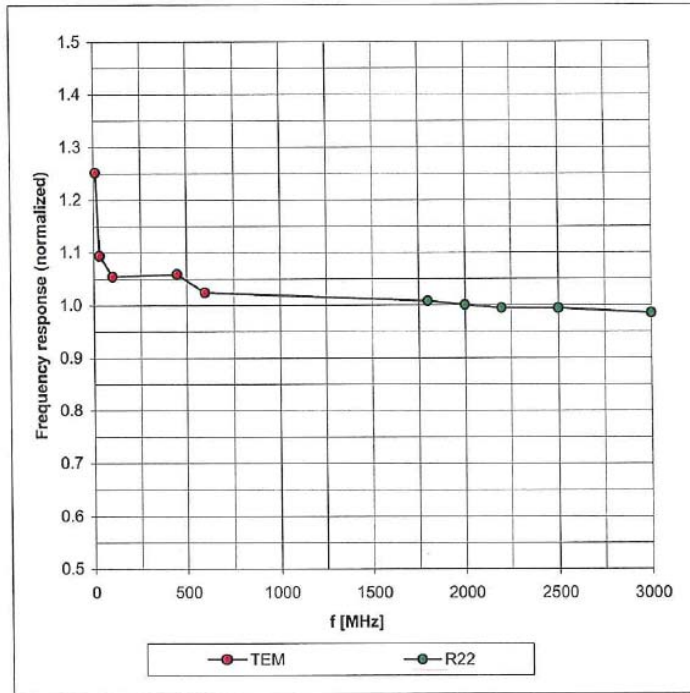

Uncertainty of Frequency Response of E-field:  $\pm 6.3\%$  ( $k=2$ )

EX3DV3 SN:3507

June 15, 2007

Receiving Pattern ( $\phi$ ),  $\theta = 0^\circ$

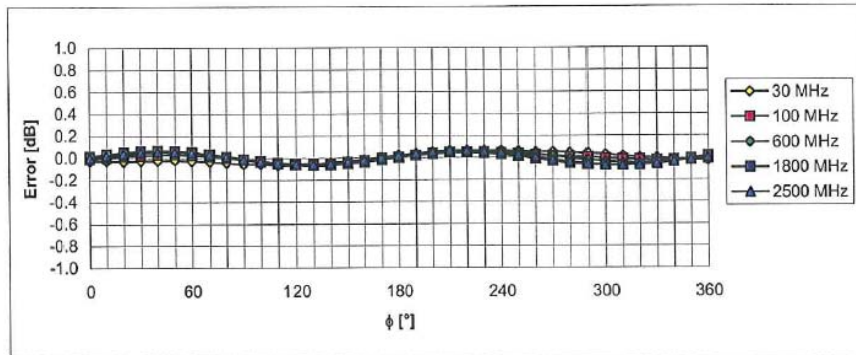
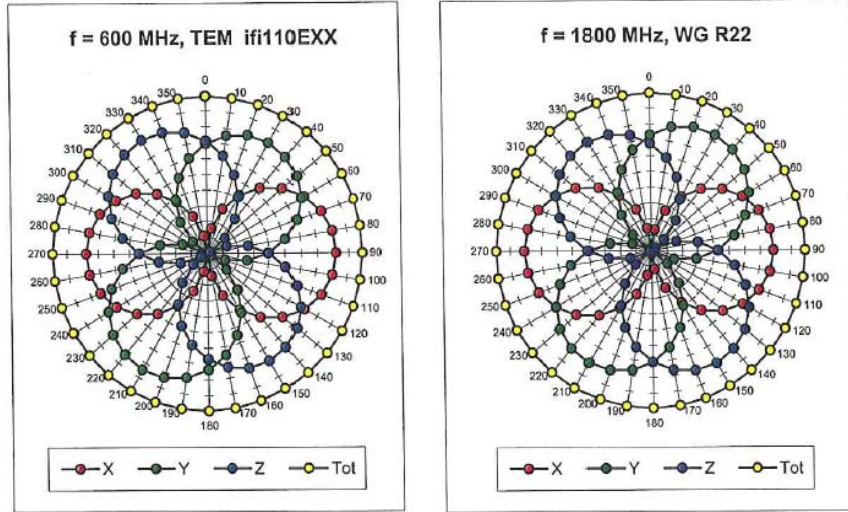

Uncertainty of Axial Isotropy Assessment:  $\pm 0.5\%$  (k=2)

EX3DV3 SN:3507

June 15, 2007

### Dynamic Range $f(\text{SAR}_{\text{head}})$ (Waveguide R22, $f = 1800 \text{ MHz}$ )

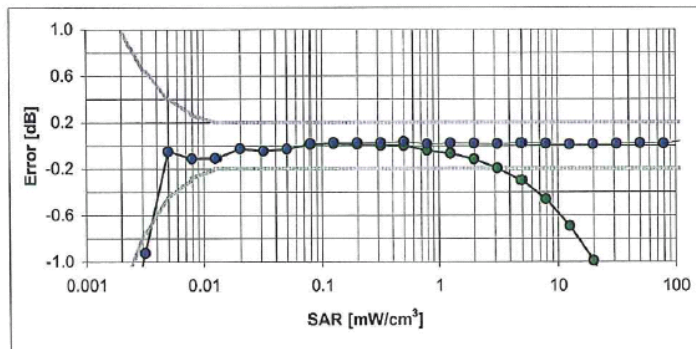
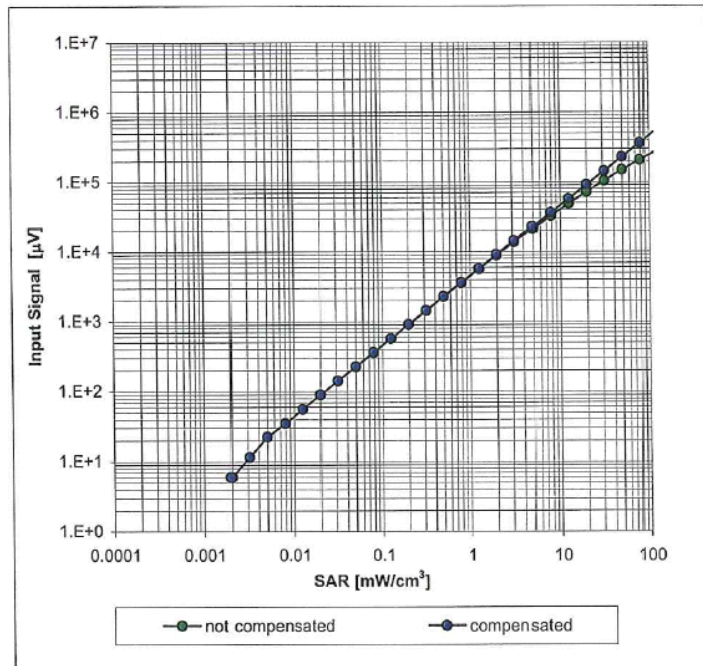

Uncertainty of Linearity Assessment:  $\pm 0.6\%$  ( $k=2$ )

EX3DV3 SN:3507

June 15, 2007

### Conversion Factor Assessment

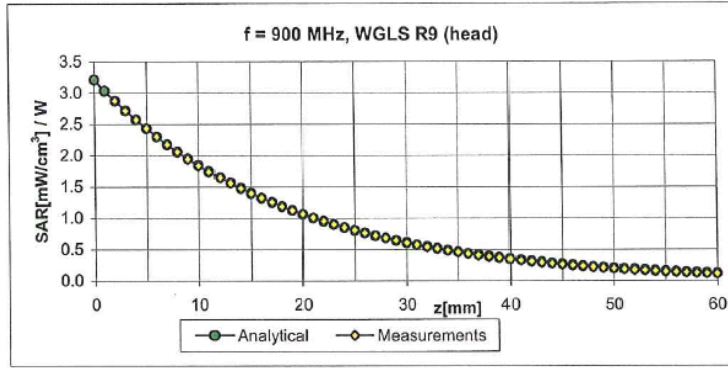

f [MHz]	Validity [MHz] <sup>c</sup>	TSL	Permittivity	Conductivity	Alpha	Depth	ConvF Uncertainty
900	± 50 / ± 100	Head	41.5 ± 5%	0.97 ± 5%	0.55	0.80	10.05 ± 11.0% (k=2)
1640	± 50 / ± 100	Head	40.3 ± 5%	1.29 ± 5%	0.22	1.00	9.61 ± 11.0% (k=2)
1810	± 50 / ± 100	Head	40.0 ± 5%	1.40 ± 5%	0.17	1.00	8.82 ± 11.0% (k=2)
2000	± 50 / ± 100	Head	40.0 ± 5%	1.40 ± 5%	0.34	1.00	8.28 ± 11.0% (k=2)
2450	± 50 / ± 100	Head	39.2 ± 5%	1.80 ± 5%	0.29	1.00	8.05 ± 11.8% (k=2)
5200	± 50 / ± 100	Head	36.0 ± 5%	4.66 ± 5%	0.32	1.75	5.46 ± 13.1% (k=2)
5500	± 50 / ± 100	Head	35.6 ± 5%	4.96 ± 5%	0.30	1.75	5.05 ± 13.1% (k=2)
5800	± 50 / ± 100	Head	35.3 ± 5%	5.27 ± 5%	0.32	1.75	4.80 ± 13.1% (k=2)
900	± 50 / ± 100	Body	55.0 ± 5%	1.05 ± 5%	0.55	0.80	9.69 ± 11.0% (k=2)
1640	± 50 / ± 100	Body	53.8 ± 5%	1.40 ± 5%	0.10	1.18	9.66 ± 11.0% (k=2)
1810	± 50 / ± 100	Body	53.3 ± 5%	1.52 ± 5%	0.12	1.34	8.93 ± 11.0% (k=2)
2000	± 50 / ± 100	Body	53.3 ± 5%	1.52 ± 5%	0.37	1.00	8.33 ± 11.0% (k=2)
2450	± 50 / ± 100	Body	52.7 ± 5%	1.95 ± 5%	0.40	1.00	8.00 ± 11.8% (k=2)
5200	± 50 / ± 100	Body	49.0 ± 5%	5.30 ± 5%	0.35	1.80	4.68 ± 13.1% (k=2)
5500	± 50 / ± 100	Body	48.6 ± 5%	5.65 ± 5%	0.32	1.80	4.33 ± 13.1% (k=2)
5800	± 50 / ± 100	Body	48.2 ± 5%	6.00 ± 5%	0.30	1.80	4.55 ± 13.1% (k=2)

<sup>c</sup> The validity of ± 100 MHz only applies for DASY v4.4 and higher (see Page 2). The uncertainty is the RSS of the ConvF uncertainty at calibration frequency and the uncertainty for the indicated frequency band.

EX3DV3 SN:3507

June 15, 2007

### Deviation from Isotropy in HSL

Error ( $\phi$ ,  $\theta$ ),  $f = 900$  MHz

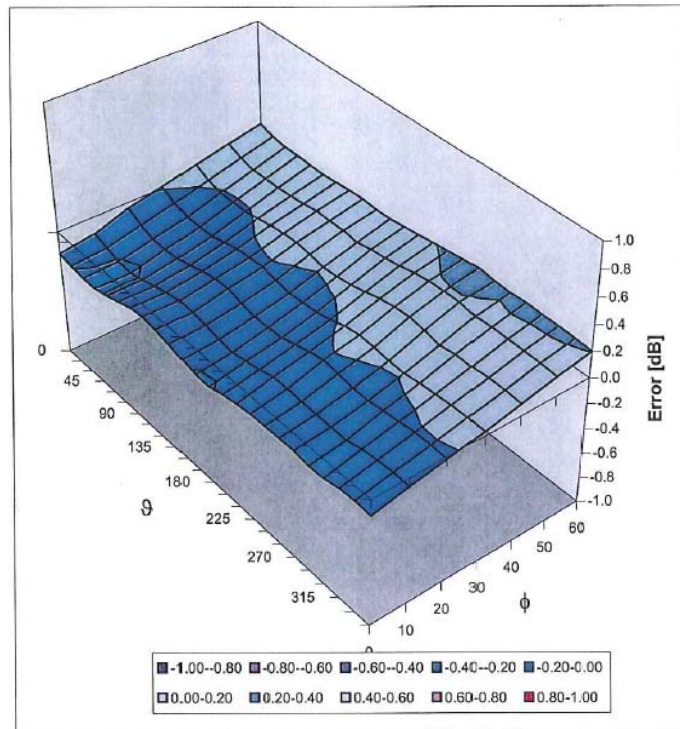

Uncertainty of Spherical Isotropy Assessment:  $\pm 2.6\%$  ( $k=2$ )

**UL Japan, Inc.**

**Head Office EMC Lab.**

4383-326 Asama-cho, Ise-shi, Mie-ken 516-0021 JAPAN

Telephone : +81 596 24 8116

Facsimile : +81 596 24 8124



### 13. References

- [1]ANSI, ANSI/IEEE C95.1-1992: IEEE Standard for Safety Levels with Respect to Human Exposure to Radio Frequency Electromagnetic Fields, 3 kHz to 300 GHz, The Institute of Electrical and Electronics Engineers, Inc., New York, NY 10017, 1992.
- [2] Katja Pokovic, Thomas Schmid, and Niels Kuster, "Robust setup for precise calibration of E-field probes in tissue simulating liquids at mobile communications frequencies", in ICECOM '97, Dubrovnik, October 15-17, 1997, pp. 120-124.
- [3] Katja Pokovic, Thomas Schmid, and Niels Kuster, "E- field probe with improved isotropy in brain simulating liquids", in Proceedings of the ELMAR, Zadar, Croatia, 23-25 June, 1996, pp.172-175.
- [4] W. Gander, Computermathematik, Birkhaeuser, Basel, 1992.
- [5] W. H. Press, S. A. Teukolsky, W. T. Vetterling, and B. P. Flannery, Numerical Recipes in C, The Art of Scientific Computing, Second Edition, Cambridge University Press, 1992.
- [6]SPEAG uncertainty document for DASY 4 System from SPEAG (Shimid & Partner Engineering AG).
- [7]SPEAG uncertainty document for "the 5-6GHz Extension" from SPEAG (Shimid & Partner Engineering AG).

---

**UL Japan, Inc.**

**Head Office EMC Lab.**

4383-326 Asama-cho, Ise-shi, Mie-ken 516-0021 JAPAN

Telephone : +81 596 24 8116

Facsimile : +81 596 24 8124