



SPECIFICATION AND PERFORMANCE FOR APPROVAL

P/N: E42-1G241000A26 2005/12/15 REV.0 1 of 38
FULL RISE ELECTRONIC CO., LTD.

No.19-4,Kao Shan Hsia,Kao Shuang Village,Pin Chen City,Taoyuan,Taiwan, TEL:+886-3-4643715 FAX:+886-3-4643720/21 http://www.fre.com.tw
No.22-23 buolding,JinBi Industry Park ,Huang Tian Village ,Baoan District,Shenzhen City,China, TEL:+86-755-27511462, FAX:+86-755-27511578

MAXTOP TELECOM ELECTRONICS CO., LTD.

C2 Area,Far East Industrial Park,Yu Yao City,Zhejiang,China TEL:+86-574-62887000-62887003 FAX:+86-574-62887063

Part No.: E42-1G241000A26

Product Description: 9 2.4G ANTENNA +MI-113+I-PEX

Customer : _____

Customer Part No.: _____

Sample Qty. _____

FRE		
Issued By	Checked BY	QA Inspection
		Yahoo Shu 2005/12/15
Sales&Marketing Group	R&D Group	QA Group

Customer		
Customer Approval: <input type="checkbox"/> Approved <input type="checkbox"/> Concessionary <input type="checkbox"/> Rejected		
Issued By	Checked BY	Approved By

Comments:

A1RFRD10

REVISION RECORD				
REV	ECO	DESCRIPTION	DRFT	CHKD

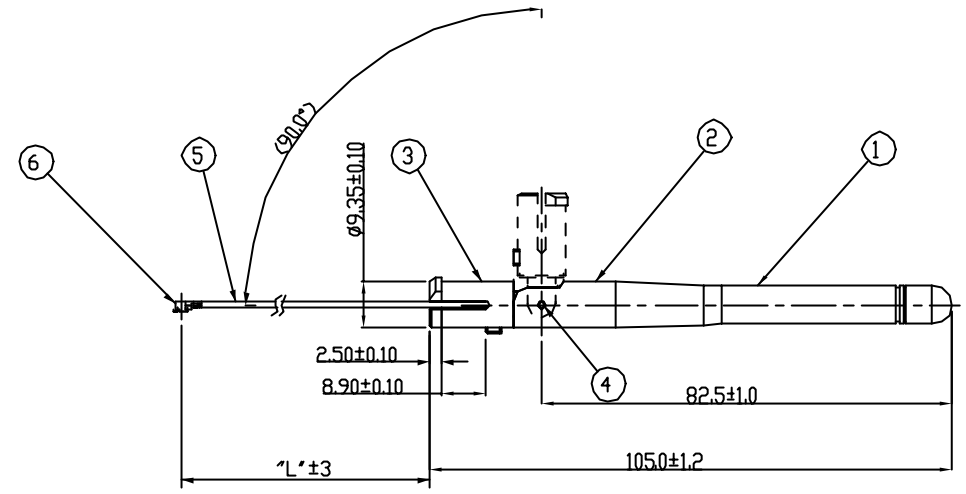

NOTE:
 ELECTRICAL PROPERTIES
 1. DESCRIPTION: 1/4 SWIVEL TYPE DIPOLE ANTENNA
 Ø9X82.5+MI-113+I-PEX CONNECTOR
 2. FREQUENCY: 2.4G~2.5G
 3. IMPEDANCE: 50 OHMS NOMINAL
 4. V.S.W.R: ≤2.0 MAX. IN BAND
 5. GAIN: NOMINAL GAIN 1.14dBi~2.14dBi, VERTICAL DIRECTION
 6. ADMITTED POWER RADIATION: 1W
 7. POLARIZATION: VERTICAL
 8. ELECTRICAL LENGTH: 1/4 , DIPOLE
 9. RADIATION: OMNI

MECHANICAL PROPERTIES
 1. CABLE: MI-113 50 OHMS
 2. OPERATING TEMPERATURE RANGE: -20°C~+65°C
 3. STORAGE TEMPERATURE RANGE: -30°C~+75°C
 4. ROHS COMPLIANT
 5. PART NUMBER: E42-1G24XXX0A26

ITEM	PART NAME	DESCRIPTION	Q'TY
1	HEAD COVER	TPEE 55D	1
2	TOP CONNECTOR	PBT+PC	1
3	DOWN CONNECTOR	PBT+PC	1
4	PIN	STEEL ZN/B	2
5	CABLE	MI-113 CABLE	1
6	CONNECTOR	I-PEX	1

L	DESCRIPTION
100	100
230	230

TOLERANCES EXCEPT AS NOTED MM .0 ± .12 .01 ± .015 .000 ± .0075		DFT: Catherine CHKD: DATE MFD: DATE APPVL: DATE	DATE 12/14/2005 DATE DATE	FULL RISE ELECTRONIC CO., LTD TITLE Ø9 2.4G ANTENNA+MI-113+I-PEX DRAWING NO. GE423C37-L /PART NO. SEE NOTE DO NOT SCALE DRAWING
ANGLES ± 0.5 THIRD ANGLE PROJECTION		MATERIAL:	QTY:	
FINISH:		SCALE: 1:1	SIZE A3 REV 0	
SHEET 1 OF 1		SHEET 1 OF 1		

**SPECIFICATION AND PERFORMANCE
FOR APPROVAL**

P/N: E42-1G241000A26 2005/12/15 REV.0 4 of 38

FULL RISE ELECTRONIC CO., LTD.No.19-4,Kao Shan Hsia,Kao Shuang Village,Pin Chen City,Taoyuan,Taiwan, TEL:+886-3-4643715 FAX:+886-3-4643720/21 <http://www.fre.com.tw>

No.22-23 buolding,JinBi Industry Park ,Huang Tian Village ,Baoan District,Shenzhen City,China, TEL:+86-755-27511462, FAX:+86-755-27511578

MAXTOP TELECOM ELECTRONICS CO., LTD.C2 Area,Far East Industrial Park,Yu Yao City,Zhejiang,China TEL:+86-574-62887000-62887003 FAX:+86-574-62887063

Electrical Properties:

1. Frequency: 2.4 ~ 2.5 MHZ
2. Impedance: 50 Ohms nominal
3. VSWR: 2.0 max. IN BAND
4. Gain :1.14 ~ 2.14 dBi,Vertical direction
5. Radiation: Omni
6. Polarization: Vertical
7. Electrical Wave: Dipole

Mechanical properties:

1. Cable:MI -113 50ohm
- 2.Operating temperature range:-20 ~+65
- 3.Storage temperature range:-30 ~+75
- 4.HEAD COVER : TPEE 55D
- 5.TOP CONNECTOR : PBT + PC
- 6.DOWN CONNECTOR: PBT+PC
- 7.PIN: SITEEL ZN/B
8. CABLE: MI-113 CABLE
- 9.CONNECTOR:I-PEX CONNECTOR

SPECIFICATION AND PERFORMANCE FOR APPROVAL

P/N: E42-1G241000A26 2005/12/15 REV.0 5 of 38
FULL RISE ELECTRONIC CO., LTD.

No.19-4,Kao Shan Hsia,Kao Shuang Village,Pin Chen City,Taoyuan,Taiwan, TEL:+886-3-4643715 FAX:+886-3-4643720/21 http://www.fre.com.tw
 No.22-23 buolding,JinBi Industry Park ,Huang Tian Village ,Baoan District,Shenzhen City,China, TEL:+86-755-27511462, FAX:+86-755-27511578

MAXTOP TELECOM ELECTRONICS CO., LTD.

C2 Area,Far East Industrial Park,Yu Yao City,Zhejiang,China TEL:+86-574-62887000-62887003 FAX:+86-574-62887063

Electrical Properties :

V.S.W.R : 2.0 Maximal in Band

Frequency	2.4 GHz	2.45 GHz	2.5 GHz
Sample 1	1.3530	1.0693	1.3500
Sample 2	1.3162	1.0592	1.3341
Sample 3	1.3090	1.0467	1.3265
Sample 4	1.3344	1.0749	1.3598
Sample 5	1.3491	1.0831	1.3675

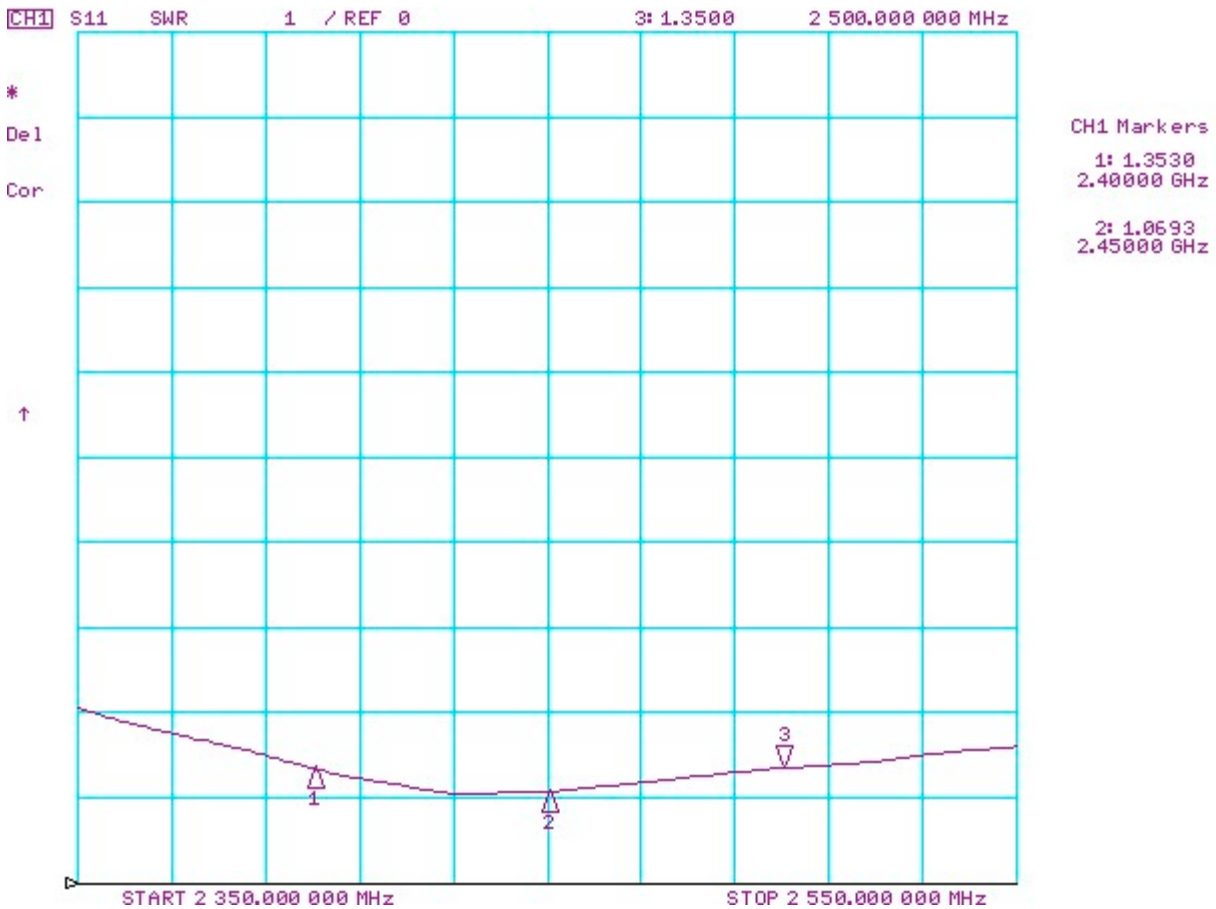

SPECIFICATION AND PERFORMANCE FOR APPROVAL

P/N: E42-1G241000A26 2005/12/15 REV.0 6 of 38
FULL RISE ELECTRONIC CO., LTD.

No.19-4,Kao Shan Hsia,Kao Shuang Village,Pin Chen City,Taoyuan,Taiwan, TEL:+886-3-4643715 FAX:+886-3-4643720/21 <http://www.fre.com.tw>
 No.22-23 buolding,JinBi Industry Park ,Huang Tian Village ,Baoan District,Shenzhen City,China, TEL:+86-755-27511462, FAX:+86-755-27511578

MAXTOP TELECOM ELECTRONICS CO., LTD.

C2 Area,Far East Industrial Park,Yu Yao City,Zhejiang,China TEL:+86-574-62887000-62887003 FAX:+86-574-62887063

Return Loss : -10 dB Maximal in Band

Frequency	2.4 GHz	2.45 GHz	2.5 GHz
Sample 1	-16.569 dB	-30.833 dB	-16.337 dB
Sample 2	-16.751 dB	-30.421 dB	-16.691 dB
Sample 3	-16.877 dB	-30.538 dB	-16.509 dB
Sample 4	-16.545 dB	-30.217 dB	-16.213 dB
Sample 5	-16.419 dB	-30.189 dB	-16.137 dB

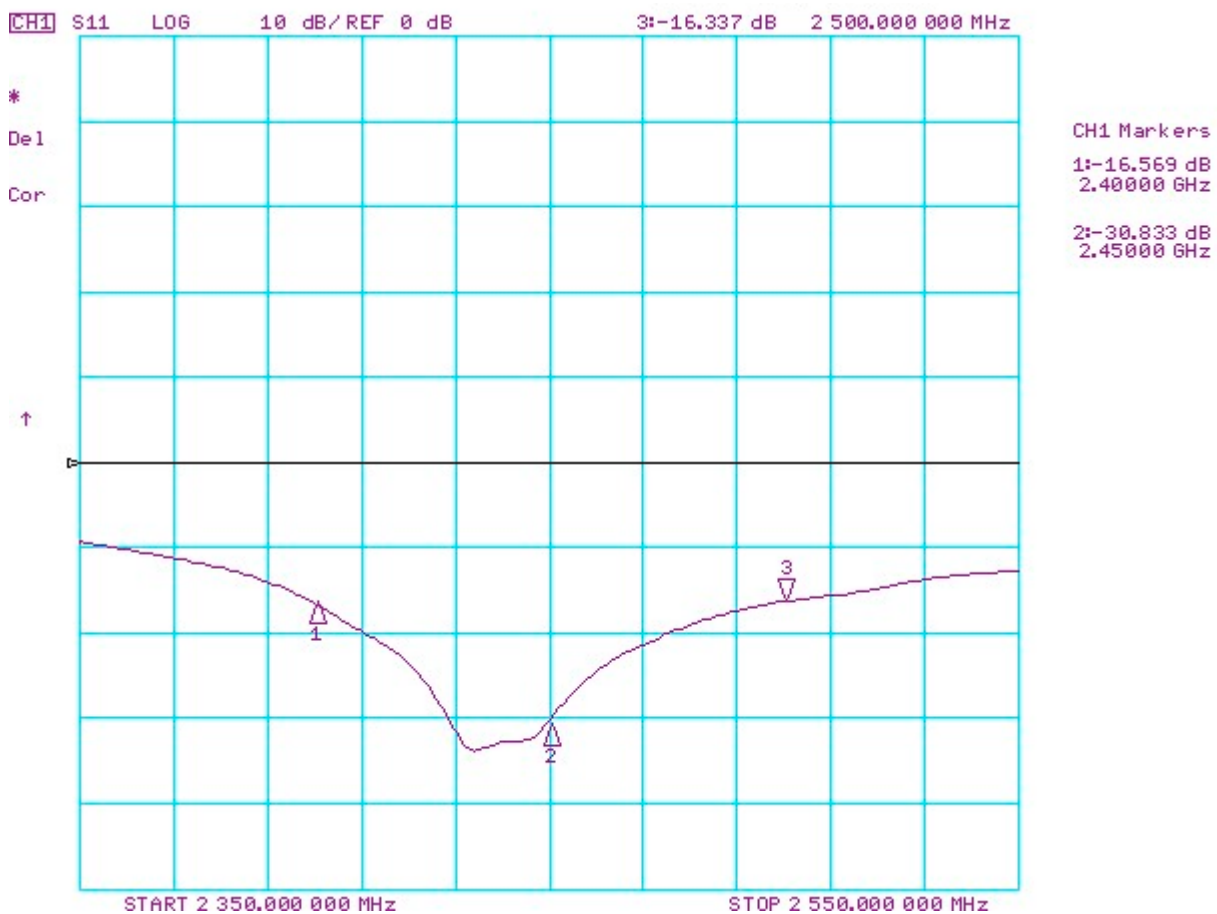

SPECIFICATION AND PERFORMANCE FOR APPROVAL

P/N: E42-1G241000A26 2005/12/15 REV.0 7 of 38

FULL RISE ELECTRONIC CO., LTD.

No.19-4,Kao Shan Hsia,Kao Shuang Village,Pin Chen City,Taoyuan,Taiwan, TEL:+886-3-4643715 FAX:+886-3-4643720/21 <http://www.fre.com.tw>
No.22-23 buolding,JinBi Industry Park ,Huang Tian Village ,Baoan District,Shenzhen City,China, TEL:+86-755-27511462, FAX:+86-755-27511578

MAXTOP TELECOM ELECTRONICS CO., LTD.

C2 Area,Far East Industrial Park,Yu Yao City,Zhejiang,China TEL:+86-574-62887000-62887003 FAX:+86-574-62887063

H-Plain 2.4GHz 3.00495dBi

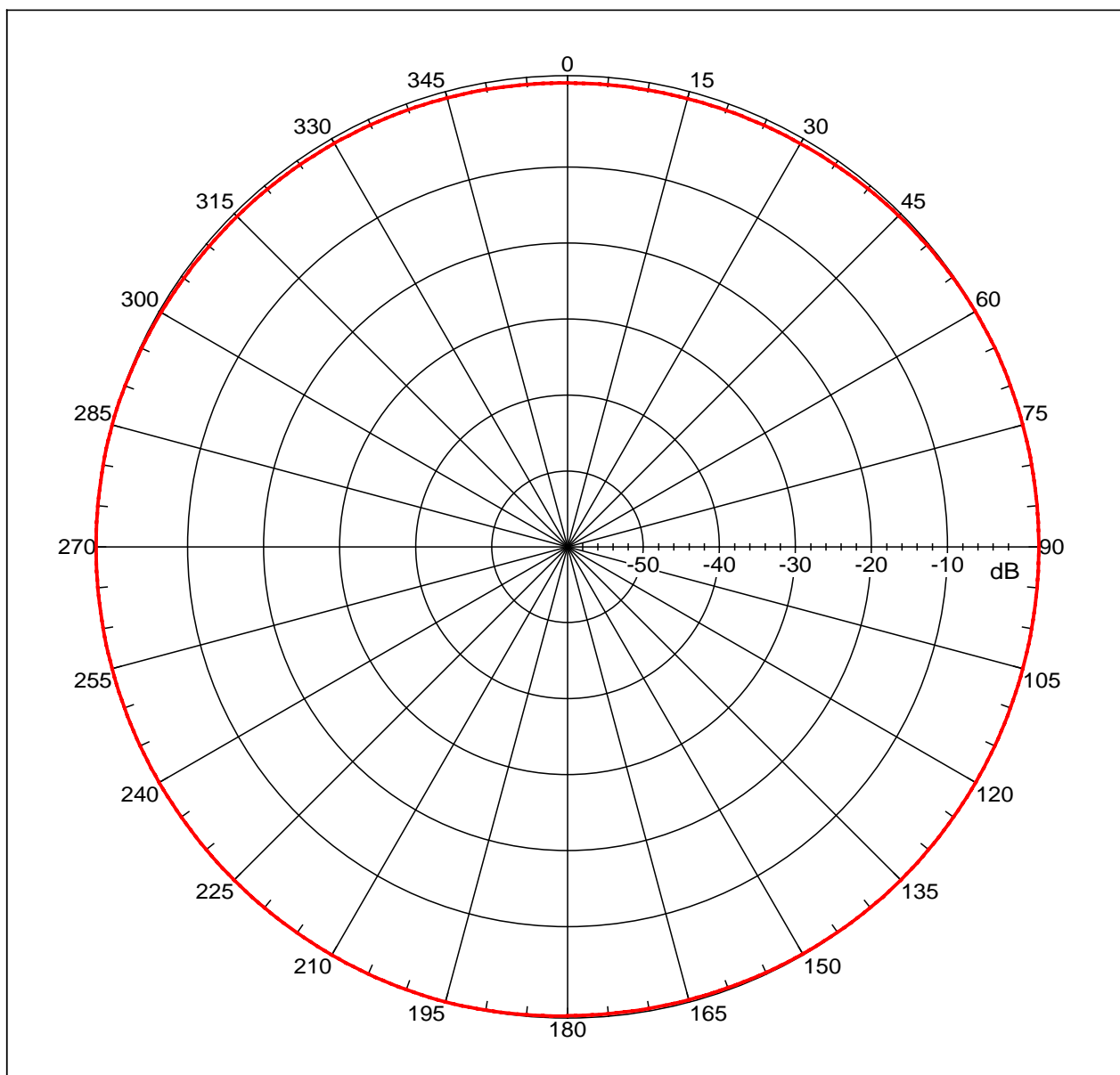



SPECIFICATION AND PERFORMANCE FOR APPROVAL

P/N: E42-1G241000A26 2005/12/15 REV.0 8 of 38

FULL RISE ELECTRONIC CO., LTD.

No.19-4,Kao Shan Hsia,Kao Shuang Village,Pin Chen City,Taoyuan,Taiwan, TEL:+886-3-4643715 FAX:+886-3-4643720/21 <http://www.fre.com.tw>
No.22-23 buolding,JinBi Industry Park ,Huang Tian Village ,Baoan District,Shenzhen City,China, TEL:+86-755-27511462, FAX:+86-755-27511578

MAXTOP TELECOM ELECTRONICS CO., LTD.

C2 Area,Far East Industrial Park,Yu Yao City,Zhejiang,China TEL:+86-574-62887000-62887003 FAX:+86-574-62887063

H-Plain 2.45GHz 2.62092dBi

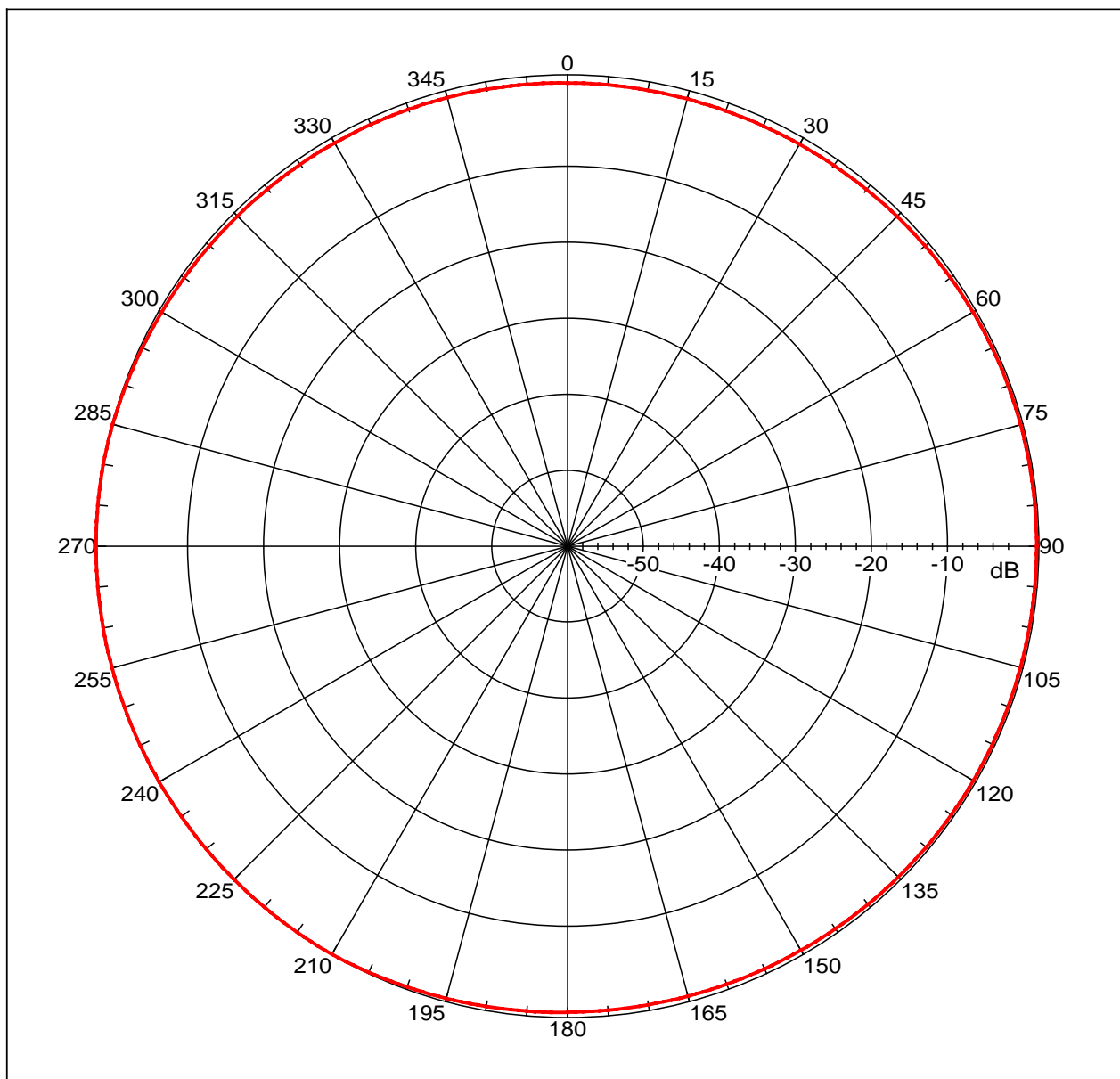



SPECIFICATION AND PERFORMANCE FOR APPROVAL

P/N: E42-1G241000A26 2005/12/15 REV.0 9 of 38
FULL RISE ELECTRONIC CO., LTD.

No.19-4,Kao Shan Hsia,Kao Shuang Village,Pin Chen City,Taoyuan,Taiwan, TEL:+886-3-4643715 FAX:+886-3-4643720/21 <http://www.fre.com.tw>
No.22-23 buolding,JinBi Industry Park ,Huang Tian Village ,Baoan District,Shenzhen City,China, TEL:+86-755-27511462, FAX:+86-755-27511578

MAXTOP TELECOM ELECTRONICS CO., LTD.

C2 Area,Far East Industrial Park,Yu Yao City,Zhejiang,China TEL:+86-574-62887000-62887003 FAX:+86-574-62887063

H-Plain 2.5GHz 2.25582dBi

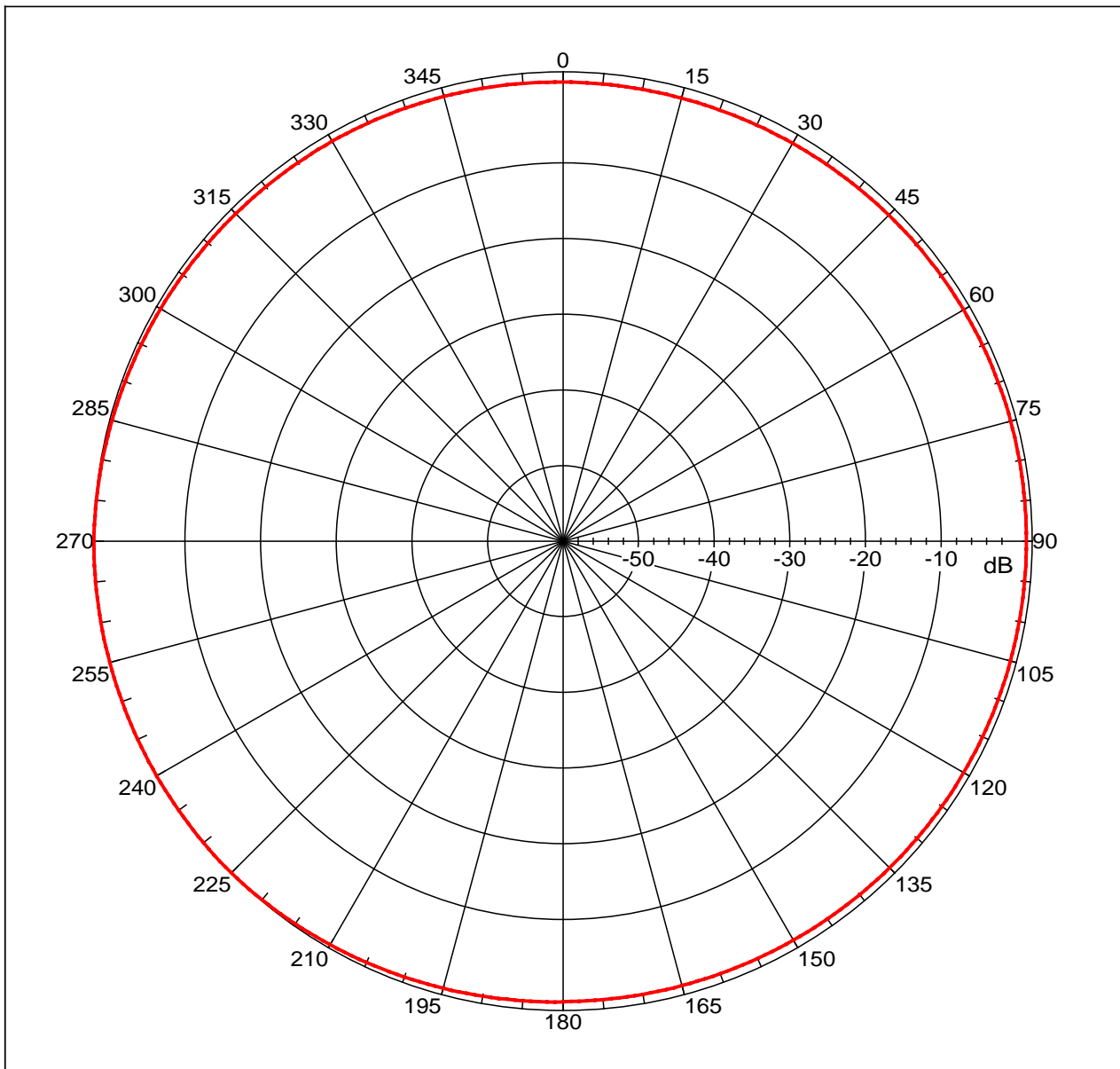

SPECIFICATION AND PERFORMANCE FOR APPROVAL

P/N: E42-1G241000A26 2005/12/15 REV.0 10 of 38

FULL RISE ELECTRONIC CO., LTD.

No.19-4,Kao Shan Hsia,Kao Shuang Village,Pin Chen City,Taoyuan,Taiwan, TEL:+886-3-4643715 FAX:+886-3-4643720/21 <http://www.fre.com.tw>
No.22-23 buolding,JinBi Industry Park ,Huang Tian Village ,Baoan District,Shenzhen City,China, TEL:+86-755-27511462, FAX:+86-755-27511578

MAXTOP TELECOM ELECTRONICS CO., LTD.

C2 Area,Far East Industrial Park,Yu Yao City,Zhejiang,China TEL:+86-574-62887000-62887003 FAX:+86-574-62887063

E-Plain 2.4GHz 2.06131dBi

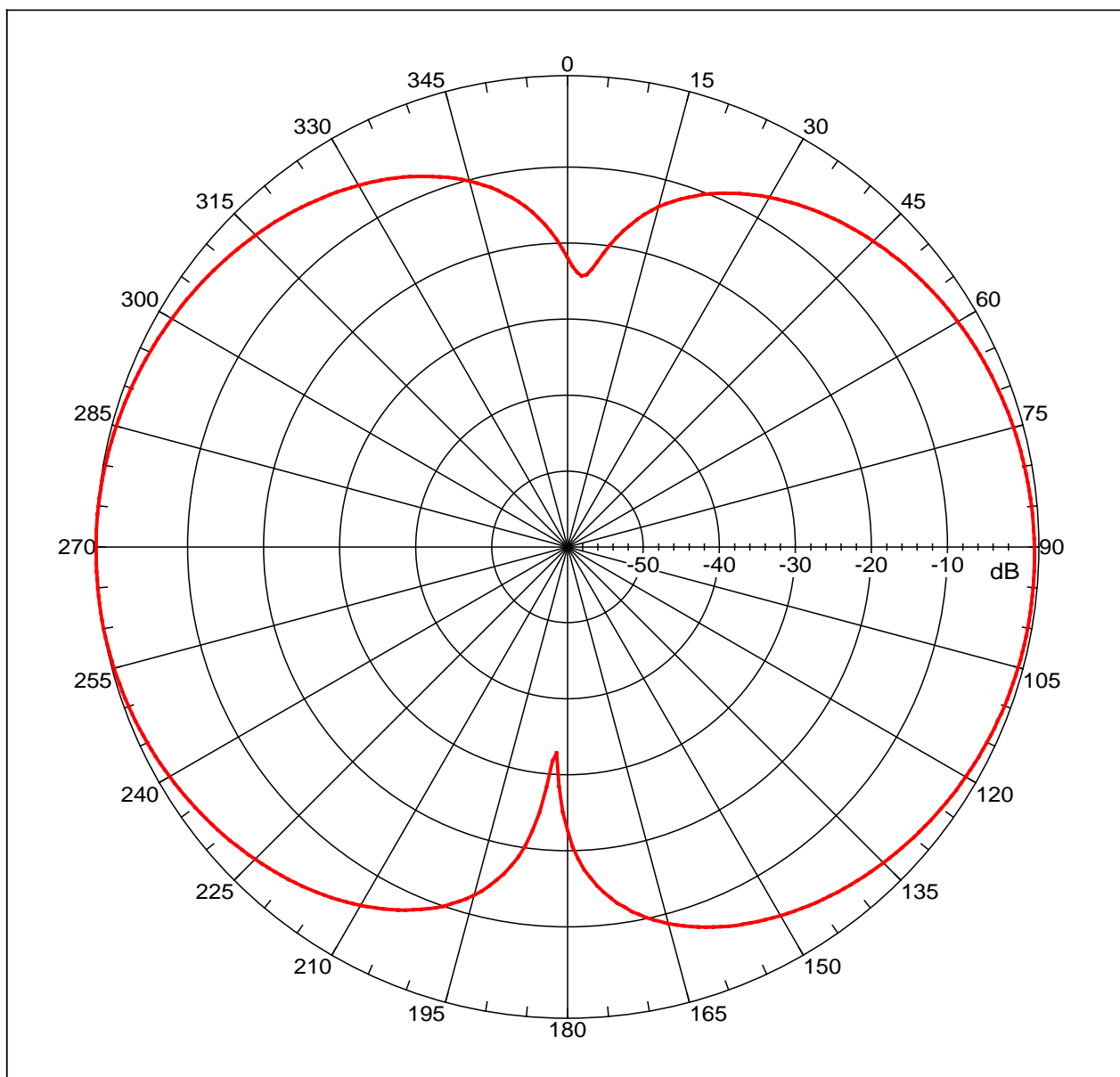

SPECIFICATION AND PERFORMANCE FOR APPROVAL

P/N: E42-1G241000A26 2005/12/15 REV.0 11 of 38

FULL RISE ELECTRONIC CO., LTD.

No.19-4,Kao Shan Hsia,Kao Shuang Village,Pin Chen City,Taoyuan,Taiwan, TEL:+886-3-4643715 FAX:+886-3-4643720/21 <http://www.fre.com.tw>
No.22-23 buolding,JinBi Industry Park ,Huang Tian Village ,Baoan District,Shenzhen City,China, TEL:+86-755-27511462, FAX:+86-755-27511578

MAXTOP TELECOM ELECTRONICS CO., LTD.

C2 Area,Far East Industrial Park,Yu Yao City,Zhejiang,China TEL:+86-574-62887000-62887003 FAX:+86-574-62887063

E-Plain 2.45GHz 2.12929dBi

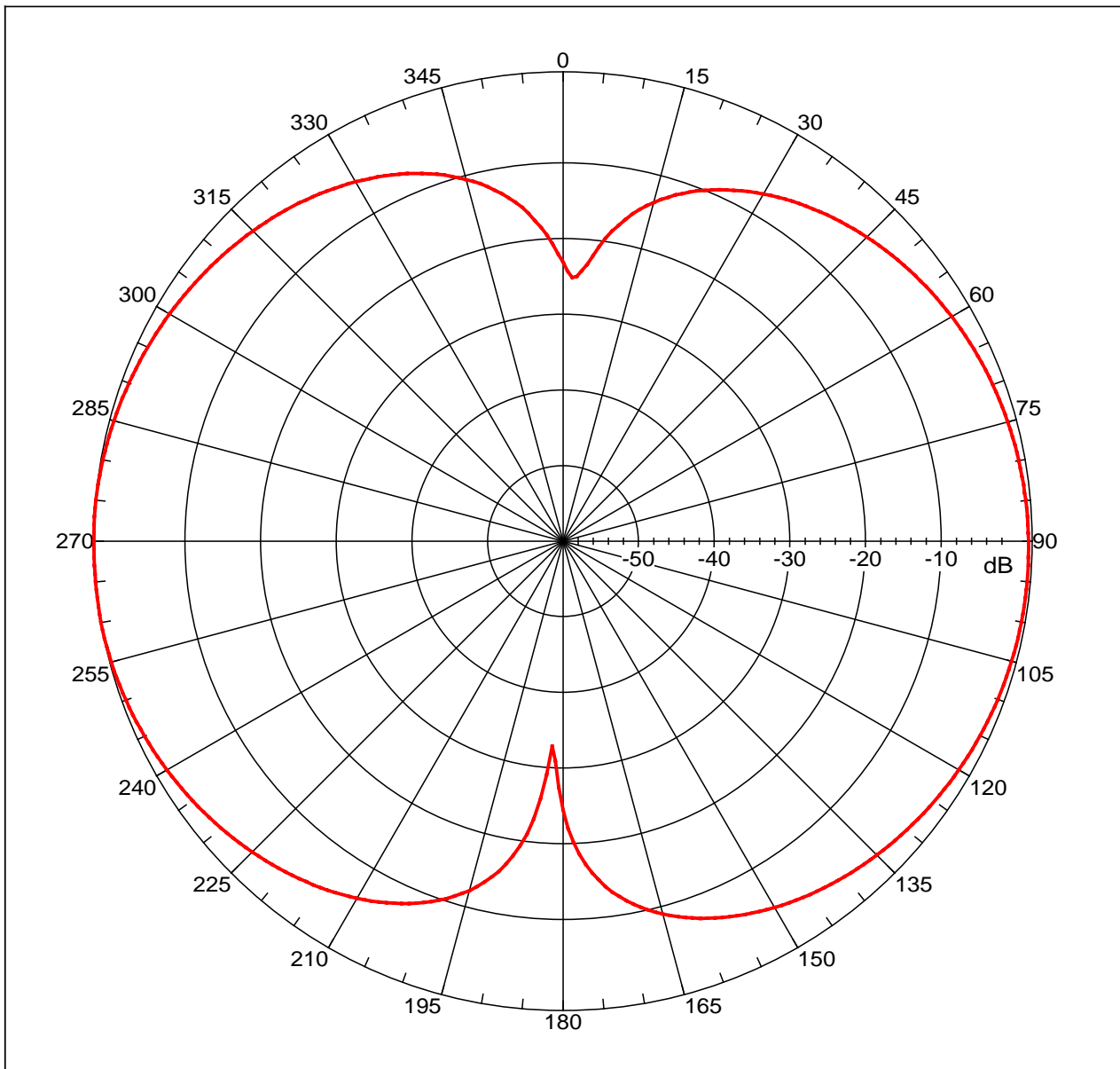



SPECIFICATION AND PERFORMANCE FOR APPROVAL

P/N: E42-1G241000A26 2005/12/15 REV.0 12 of 38

FULL RISE ELECTRONIC CO., LTD.

No.19-4,Kao Shan Hsia,Kao Shuang Village,Pin Chen City,Taoyuan,Taiwan, TEL:+886-3-4643715 FAX:+886-3-4643720/21 <http://www.fre.com.tw>
No.22-23 buolding,JinBi Industry Park ,Huang Tian Village ,Baoan District,Shenzhen City,China, TEL:+86-755-27511462, FAX:+86-755-27511578

MAXTOP TELECOM ELECTRONICS CO., LTD.

C2 Area,Far East Industrial Park,Yu Yao City,Zhejiang,China TEL:+86-574-62887000-62887003 FAX:+86-574-62887063

E-Plain 2.5GHz 2.44202dBi

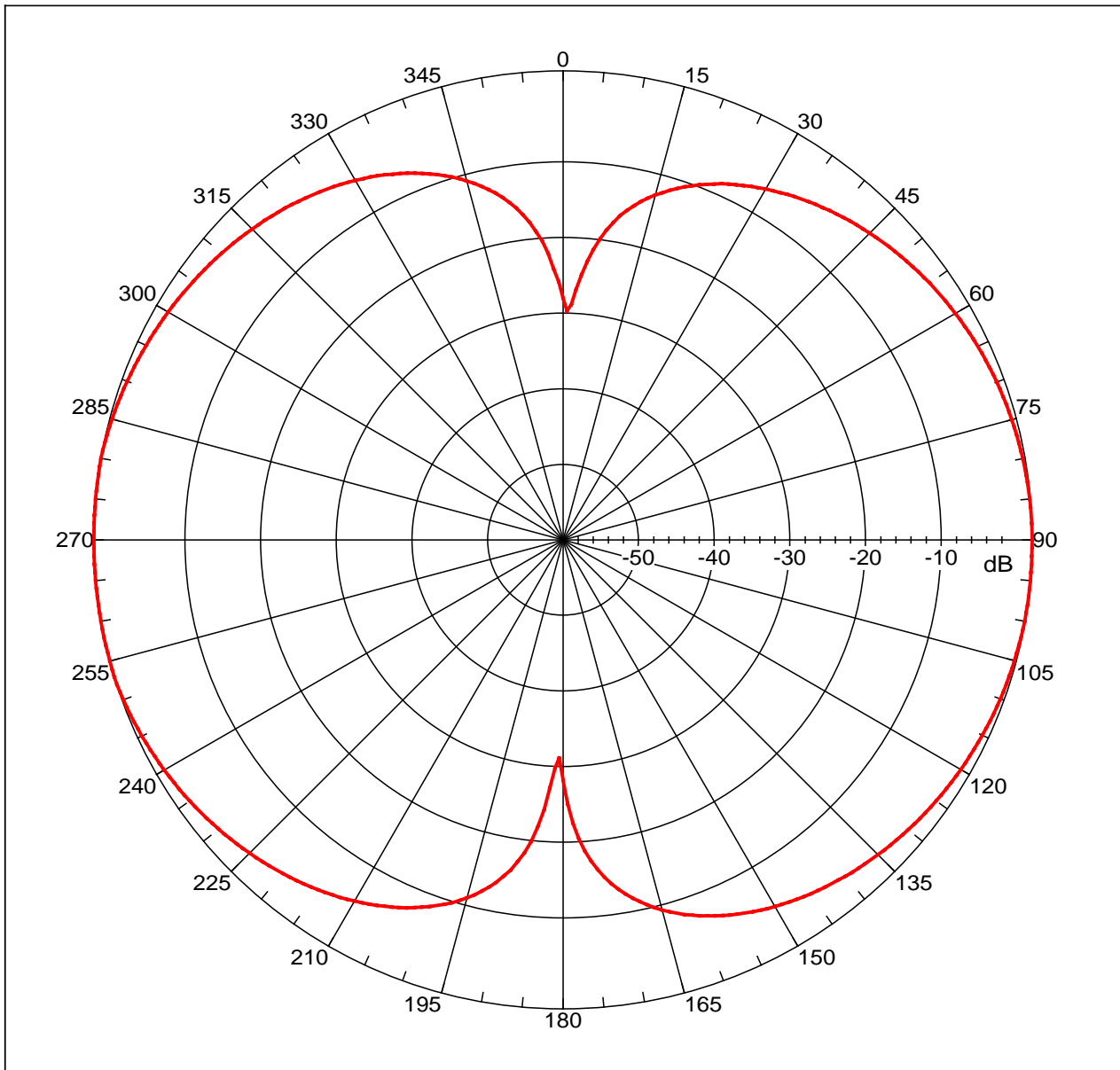

Test Report

FULL RISE ELECTRONIC CO., LTD.
NO. 26, KAO CHING RD., YANG MEI CHEN, TAOYUAN
HSIEN, TAIWAN

Report No. : CE/2005/83922
Date : 2005/08/23
Page : 1 of 4

The following merchandise was (were) submitted and identified by the client as :

Type of Product : TOP CONNECTOR, DOWN CONNECTOR, HEAD COVER, FIXED PLATE, PBT + PC, BLACK

Style/Item No : (1) P4201-0116H1(2) P4201-0156H1(3) P4201-0186H1
(4) P4201-01A6H1(5) P4201-01C6H1(6) P4201-01E6H1
(7) P4201-01F6H1(8) P4201-01G6H1(9) P4201-01M6H1
(10) P4201-01T6H1(11) P4201-01U6H1(12) P4201-01Y6H1
(13) P4201-0256H1(14) P4201-02A6H1(15) P4201-02C6H1
(16) P4201-02F6H1(17) P4201-02N6H1(18) P4201-0316H1
(19) P4201-03F6H1(20) P4201-03N6H1(21) P4201-0816H1
(22) P4201-1016H1(23) P4201-1116H1(24) P4201-1616H1
(25) P4201-1716H1(26) P4201-2116H1(27) P4201-2256H1
(28) P4201-2356H1(29) P4202-0156H1(30) P4202-0186H1
(31) P4202-01A6H1(32) P4202-01C6H1(33) P4202-01E6H1
(34) P4202-01F6H1(35) P4202-01G6H1
(36) P4202-01M6H1(37) P4202-01T6H1(38) P4202-01Y6H1
(39)P4202-0216H1 (40) P4202-02N6H1(41) P4202-05R6H1
(42) P4202-0916H1(43) P4202-0716H1(44) P4202-1116H1
(45) P4202-1416H1(46) P4203-01U6H1(47) P4203-02U6H1
(48) P4206-0166H1

Sample Received : 2005/08/16

Testing Date : 2005/08/16 TO 2005/08/23

=====
Test Result : - Please see the next page -

Daniel Yeh, M.R. / Operation Manager
Signed for and on behalf of
SGS TAIWAN LTD.

Test Report

FULL RISE ELECTRONIC CO., LTD.
 NO. 26, KAO CHING RD., YANG MEI CHEN, TAOYUAN
 HSIEN, TAIWAN

Report No. : CE/2005/83922
 Date : 2005/08/23
 Page : 2 of 4

Test Result

PART NAME NO.1 : MIXED ALL BLACK PLASTIC (PLEASE REFER TO THE PHOTO ATTACHED)

Test Item (s):	Unit	Method	MDL	Result
				No.1
Monobromobiphenyl	%	With reference to USEPA3540C or USEPA3550C. Analysis was performed by HPLC/DAD, LC/MS or GC/MS. (prohibited by 2002/95/EC (RoHS), 83/264/EEC, and 76/769/EEC)	0.0005	N.D.
Dibromobiphenyl	%		0.0005	N.D.
Tribromobiphenyl	%		0.0005	N.D.
Tetrabromobiphenyl	%		0.0005	N.D.
Pentabromobiphenyl	%		0.0005	N.D.
Hexabromobiphenyl	%		0.0005	N.D.
Heptabromobiphenyl	%		0.0005	N.D.
Octabromobiphenyl	%		0.0005	N.D.
Nonabromobiphenyl	%		0.0005	N.D.
Decabromobiphenyl	%		0.0005	N.D.
Total PBBs (Polybrominated biphenyls)/Sum of above	%		-	N.D.
Monobromobiphenyl ether	%	With reference to USEPA3540C or USEPA3550C. Analysis was performed by HPLC/DAD, LC/MS or GC/MS. (prohibited by 2002/95/EC (RoHS), 83/264/EEC, and 76/769/EEC)	0.0005	N.D.
Dibromobiphenyl ether	%		0.0005	N.D.
Tribromobiphenyl ether	%		0.0005	N.D.
Tetrabromobiphenyl ether	%		0.0005	N.D.
Pentabromobiphenyl ether	%		0.0005	N.D.
Hexabromobiphenyl ether	%		0.0005	N.D.
Heptabromobiphenyl ether	%		0.0005	N.D.
Octabromobiphenyl ether	%		0.0005	N.D.
Nonabromobiphenyl ether	%		0.0005	N.D.
Decabromobiphenyl ether	%		0.0005	N.D.
Total PBBEs(PBDEs)(Polybrominated biphenyl ethers)/Sum of above	%		-	N.D.

Test Report

FULL RISE ELECTRONIC CO., LTD.
 NO. 26, KAO CHING RD., YANG MEI CHEN, TAOYUAN
 HSIEN, TAIWAN

Report No. : CE/2005/83922
 Date : 2005/08/23
 Page : 3 of 4

Test Item (s):	Unit	Method	MDL	Result
				No.1
Chromium VI (Cr+6)	ppm	UV-VIS after reference to US EPA 3060A.	2	N.D.
Cadmium (Cd)	ppm	ICP-AES after reference to EN 1122, method B:2001 or other acid digestion.	2	N.D.
Mercury (Hg)	ppm	ICP-AES after reference to US EPA 3052 or other acid digestion.	2	N.D.
Lead (Pb)	ppm	ICP-AES after reference to US EPA 3050B or other acid digestion.	2	N.D.

NOTE: (1) N.D. = Not detected (<MDL)
 (2) ppm = mg/kg
 (3) MDL = Method Detection Limit
 (4) " - " = No Regulation

Test Report

FULL RISE ELECTRONIC CO., LTD.
NO. 26, KAO CHING RD., YANG MEI CHEN, TAOYUAN
HSIEN, TAIWAN

Report No. : CE/2005/83922
Date : 2005/08/23
Page : 4 of 4



Test Report

FULL RISE ELECTRONIC CO., LTD.
NO. 26, KAO CHING RD., YANG MEI CHEN, TAOYUAN
HSIEN, TAIWAN

Report No. : CE/2005/83918
Date : 2005/08/23
Page : 1 of 4

The following merchandise was (were) submitted and identified by the client as :

Type of Product : HEAD COVER, BLACK
Style/Item No : (1) P4203-01YP13 (2) P4203-015P13 (3) P4203-205P13
(4) P4203-03FP02 (5) P4203-01CP13 (6) P4203-01CP01
(7) P4203-01GP13 (8) P4203-01GP01 (9) P4203-01EP13
(10) P4203-01TP13(11) P4203-01MP13 (12) P4203-018P13
(13) P4203-01NP13(14) P4203-016P01 (15) P4203-207P01
(16) P4203-016P13 (17) P4203-021P13(18) P4203-01AP13
(19) P4203-01AP01
Sample Received : 2005/08/16
Testing Date : 2005/08/16 TO 2005/08/23

=====
Test Result : - Please see the next page -

Daniel Yeh, M.R. / Operation Manager
Signed for and on behalf of
SGS TAIWAN LTD.

Test Report

FULL RISE ELECTRONIC CO., LTD.
 NO. 26, KAO CHING RD., YANG MEI CHEN, TAOYUAN
 HSIEN, TAIWAN

Report No. : CE/2005/83918
 Date : 2005/08/23
 Page : 2 of 4

Test Result

PART NAME NO.1 : MIXED ALL BLACK PLASTIC (PLEASE REFER TO THE PHOTO ATTACHED)

Test Item (s):	Unit	Method	MDL	Result
				No.1
Monobromobiphenyl	%	With reference to USEPA3540C or USEPA3550C. Analysis was performed by HPLC/DAD, LC/MS or GC/MS. (prohibited by 2002/95/EC (RoHS), 83/264/EEC, and 76/769/EEC)	0.0005	N.D.
Dibromobiphenyl	%		0.0005	N.D.
Tribromobiphenyl	%		0.0005	N.D.
Tetrabromobiphenyl	%		0.0005	N.D.
Pentabromobiphenyl	%		0.0005	N.D.
Hexabromobiphenyl	%		0.0005	N.D.
Heptabromobiphenyl	%		0.0005	N.D.
Octabromobiphenyl	%		0.0005	N.D.
Nonabromobiphenyl	%		0.0005	N.D.
Decabromobiphenyl	%		0.0005	N.D.
Total PBBs (Polybrominated biphenyls)/Sum of above	%		-	N.D.
Monobromobiphenyl ether	%	With reference to USEPA3540C or USEPA3550C. Analysis was performed by HPLC/DAD, LC/MS or GC/MS. (prohibited by 2002/95/EC (RoHS), 83/264/EEC, and 76/769/EEC)	0.0005	N.D.
Dibromobiphenyl ether	%		0.0005	N.D.
Tribromobiphenyl ether	%		0.0005	N.D.
Tetrabromobiphenyl ether	%		0.0005	N.D.
Pentabromobiphenyl ether	%		0.0005	N.D.
Hexabromobiphenyl ether	%		0.0005	N.D.
Heptabromobiphenyl ether	%		0.0005	N.D.
Octabromobiphenyl ether	%		0.0005	N.D.
Nonabromobiphenyl ether	%		0.0005	N.D.
Decabromobiphenyl ether	%		0.0005	N.D.
Total PBBEs(PBDEs)(Polybrominated biphenyl ethers)/Sum of above	%		-	N.D.

Test Report

FULL RISE ELECTRONIC CO., LTD.
 NO. 26, KAO CHING RD., YANG MEI CHEN, TAOYUAN
 HSIEN, TAIWAN

Report No. : CE/2005/83918
 Date : 2005/08/23
 Page : 3 of 4

Test Item (s):	Unit	Method	MDL	Result
				No.1
Chromium VI (Cr+6)	ppm	UV-VIS after reference to US EPA 3060A.	2	N.D.
Cadmium (Cd)	ppm	ICP-AES after reference to EN 1122, method B:2001 or other acid digestion.	2	N.D.
Mercury (Hg)	ppm	ICP-AES after reference to US EPA 3052 or other acid digestion.	2	N.D.
Lead (Pb)	ppm	ICP-AES after reference to US EPA 3050B or other acid digestion.	2	N.D.

NOTE: (1) N.D. = Not detected (<MDL)
 (2) ppm = mg/kg
 (3) MDL = Method Detection Limit
 (4) " - " = No Regulation

Test Report

FULL RISE ELECTRONIC CO., LTD.
NO. 26, KAO CHING RD., YANG MEI CHEN, TAOYUAN
HSIEN, TAIWAN

Report No. : CE/2005/83918
Date : 2005/08/23
Page : 4 of 4





Test Report

HSIEH SHUN PLATING CO., LTD.
 NO. 19, KUNG YEH 1TH RD., PING CHEN TSUEN
 TAOYUAN, TAIWAN, R. O. C.

Report No. : CE/2004/C4060
 Date : 2004/12/28
 Page : 1

The following merchandise was (were) submitted and identified by the client as :

Type of Product : 三價鉻測試片
 Sample Received : 2004/12/22
 Testing Date : 2004/12/22 TO 2004/12/28

Test Result

PART NAME NO.1 : SILVER-COLORFUL METAL SHEET (PLEASE REFER TO THE PHOTO ATTACHED)

Test Item (s):	Unit	Method	MDL	Result			
				No.1			
Chromium VI (Cr+6)	ppm	As per US EPA 7196A and US EPA 3060A.	2	N.D.			
Cadmium (Cd)	ppm	ICP-AES after as per EN 1122, method B:2001 or other acid digestion.	2	N.D.			
Mercury (Hg)	ppm	ICP-AES after as per US EPA 3052 or other acid digestion.	2	N.D.			
Lead (Pb)	ppm	ICP-AES after as per US EPA 3050B or other acid digestion.	2	23.4			

NOTE: (1) N.D. = Not detected (<MDL)
 (2) ppm = mg/kg
 (3) MDL = Method Detection Limit

 David Yeh, M.R. / Operation Manager
 Signed for and on behalf of
 SGS TAIWAN LTD.

Test Report

HUOM MING METAL CO., LTD.
NO. 5, LINE 548 SEC. 3, CHAN TAI RD., WUGU, TAIPEI,
TAIWAN

Report No. : CE/2005/55781
Date : 2005/06/02
Page : 1 of 1

The following merchandise was (were) submitted and identified by the client as :

Type of Product : LEAD LESS FREE CUTTING BRASS
Style/Item No : TB3
Sample Received : 2005/05/30
Testing Date : 2005/05/30 TO 2005/06/02

Test Results

PART NAME NO.1 : COPPER COLORED METAL STICK

Test Item (sp)	Unit	Method	MDL	Result
				No.1
Chromium VI (Cr+6)	ppm	UV-VIS after reference to US EPA 3060A.	2	N.D.
Cadmium (Cd)	ppm	ICP-AES after reference to EN 1182, method B:2001 or other acid digestion.	2	N.D.
Mercury (Hg)	ppm	ICP-AES after reference to US EPA 3052 or other acid digestion.	2	N.D.
Lead (Pb)	ppm	ICP-AES after reference to US EPA 3080B or other acid digestion.	2	20.9

NOTE: (1) N.D. = Not detected (<MDL)
(2) ppm = mg/kg
(3) MDL = Method Detection Limit

Daniel Yen, M.P., Operation Manager
Signed for and on behalf of
SGS TAIWAN LTD.

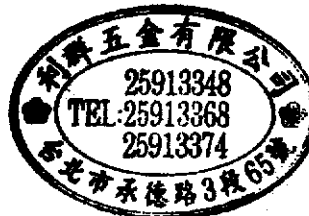



Test Report

WONDERFUL HI-TECH CO., LTD.
NO. 17, PEI-YUAN ROAD., CHUNG-LI IND, PARK,
TAOYUAN TAIWAN, R. O. C.

Report No. : CE/2004/C1639A
Date : 2004/12/16
Page : 1 of 3

The following merchandise was (were) submitted and identified by the client as :

Type of Product : MINI COAXIAL CABLE 1.13MM SERIES
Sample Received : 2004/12/09
Testing Date : 2004/12/09 TO 2004/12/16

=====
Test Result : - Please see the next page -

Daniel Yeh, M.R. / Operation Manager
Signed for and on behalf of
SGS TAIWAN LTD.



Test Report

WONDERFUL HI-TECH CO., LTD.
NO. 17, PEI-YUAN ROAD., CHUNG-LI IND, PARK,
TAOYUAN TAIWAN, R. O. C.

Report No. : CE/2004/C1639A
Date : 2004/12/16
Page : 2 of 3

Test Result

PART NAME NO.1 : RED FEP JACKET(PLEASE REFER TO THE PHOTO ATTACHED)

Test Item (s):	Unit	Method	MDL	Result			
				No.1			
PBBs(Polybrominated biphenyls)(CAS NO:059536-65-1)	%	With reference to USEPA3540 or USEPA3550. Analysis was performed by HPLC/DAD, LC/MS or GC/MS. (prohibited by 2002/95/EC (RoHS), 83/264/EEC, and 76/769/EEC)	0.0005	N.D.			
PBBEs(PBDEs)(Polybrominated biphenyl ethers)	%	With reference to USEPA3540 or USEPA3550. Analysis was performed by HPLC/DAD, LC/MS or GC/MS. (prohibited by 2002/95/EC (RoHS), 83/264/EEC, and 76/769/EEC)	0.0005	N.D.			

Test Item (s):	Unit	Method	MDL	Result			
				No.1			
Chromium VI (Cr+6)	ppm	As per US EPA 7196A and US EPA 3060A.	2	N.D.			
Cadmium (Cd)	ppm	ICP-AES after as per EN 1122, method B:2001 or other acid digestion.	2	N.D.			
Mercury (Hg)	ppm	ICP-AES after as per US EPA 3052 or other acid digestion.	2	N.D.			
Lead (Pb)	ppm	ICP-AES after as per US EPA 3050B or other acid digestion.	2	N.D.			

NOTE : (1) N.D. = Not detected (<MDL)
(2) ppm = mg/kg
(3) MDL = Method Detection Limit

Test Report

WONDERFUL HI-TECH CO., LTD.
NO. 17, PEI-YUAN ROAD., CHUNG-LI IND, PARK,
TAOYUAN TAIWAN, R. O. C.

Report No. : CE/2004/C1639A
Date : 2004/12/16
Page : 3 of 3





Test Report

I-PEX JP CO., LTD.

6-27-19 HARAMACHIDA MACHIDA-CITY TOKYO 194-0013
JAPAN

Report No. : CE/2005/61647A

Date : 2005/06/15

Page : 1 of 12

The following merchandise was (were) submitted and identified by the client as :

<u>Type of Product</u>	:	MHF SERIES CONNECTOR
<u>Style/Item No</u>	:	20278-XXXX-XX/20311-XXXX-XX/20351-XXXX-XX/ 20367-XXXX/20279-001E-01/20369-001E
<u>Sample Received</u>	:	2005/06/08
<u>Testing Date</u>	:	2005/06/08 TO 2005/06/15

Test Result : - Please see the next page -

 Daniel Yeh, M.R. / Operation Manager
 Signed for and on behalf of
 SGS TAIWAN LTD.

The content of this PDF file is in accordance with the original issued reports for reference only. This Test Report cannot be reproduced, except in full, without prior written permission of the Company



Test Report

I-PEX JP CO., LTD.

6-27-19 HARAMACHIDA MACHIDA-CITY TOKYO 194-0013
JAPAN

Report No. : CE/2005/61647A

Date : 2005/06/15

Page : 2 of 12

Test Result

PART NAME NO.1 : COPPER METAL (PLEASE REFER TO THE PHOTO ATTACHED)

PART NAME NO.2 BLACK AND WHITE PLASTIC (PLEASE REFER TO THE PHOTO ATTACHED)

Test Item (s):	Unit	Method	MDL	Result	
				No.1	No.2
Carbon tetrachloride	ppm	With reference to US EPA 8260. Analysis was performed by GC/MS linked Headspace.	1	N.D.	N.D.

Test Item (s):	Unit	Method	MDL	Result	
				No.1	No.2
CFC's(Chlorofluorocarbons)		Analysis was performed by GC/MS. [CFC's (Chlorofluorocarbons)]			
Group I					
Chlorofluorocarbon-11(CAS No:000075-69-4)	ppm	Analysis was performed by GC/MS. [CFC's (Chlorofluorocarbons)]	1	N.D.	N.D.
Chlorofluorocarbon-12(CAS No:000075-71-8)	ppm	Analysis was performed by GC/MS. [CFC's (Chlorofluorocarbons)]	1	N.D.	N.D.
Chlorofluorocarbon-113(CAS No:000076-13-1)	ppm	Analysis was performed by GC/MS. [CFC's (Chlorofluorocarbons)]	1	N.D.	N.D.
Chlorofluorocarbon-114(CAS No:000076-14-2)	ppm	Analysis was performed by GC/MS. [CFC's (Chlorofluorocarbons)]	1	N.D.	N.D.
Chlorofluorocarbon-115(CAS No:000076-15-3)	ppm	Analysis was performed by GC/MS. [CFC's (Chlorofluorocarbons)]	1	N.D.	N.D.
Group III					
Chlorofluorocarbon-13(CAS No:000075-72-9)	ppm	Analysis was performed by GC/MS. [CFC's (Chlorofluorocarbons)]	1	N.D.	N.D.

The content of this PDF file is in accordance with the original issued reports for reference only. This Test Report cannot be reproduced, except in full, without prior written permission of the Company



Test Report

I-PEX JP CO., LTD.

6-27-19 HARAMACHIDA MACHIDA-CITY TOKYO 194-0013
JAPAN

Report No. : CE/2005/61647A

Date : 2005/06/15

Page : 3 of 12

Test Item (s):	Unit	Method	MDL	Result	
				No.1	No.2
Chlorofluorocarbon-111(CAS No:000354-56-3)	ppm	Analysis was performed by GC/MS. [CFC's (Chlorofluorocarbons)]	1	N.D.	N.D.
Chlorofluorocarbon-112(CAS No:000076-12-0)	ppm	Analysis was performed by GC/MS. [CFC's (Chlorofluorocarbons)]	1	N.D.	N.D.
Chlorofluorocarbon-211(CAS No:135401-87-5)	ppm	Analysis was performed by GC/MS. [CFC's (Chlorofluorocarbons)]	1	N.D.	N.D.
Chlorofluorocarbon-212(CAS No:076564-99-3)	ppm	Analysis was performed by GC/MS. [CFC's (Chlorofluorocarbons)]	1	N.D.	N.D.
Chlorofluorocarbon-213(CAS No:060285-54-3)	ppm	Analysis was performed by GC/MS. [CFC's (Chlorofluorocarbons)]	1	N.D.	N.D.
Chlorofluorocarbon-214(CAS No:002268-46-4)	ppm	Analysis was performed by GC/MS. [CFC's (Chlorofluorocarbons)]	1	N.D.	N.D.
Chlorofluorocarbon-215(CAS No:000076-17-5)	ppm	Analysis was performed by GC/MS. [CFC's (Chlorofluorocarbons)]	1	N.D.	N.D.
Chlorofluorocarbon-216(CAS No:001652-80-8)	ppm	Analysis was performed by GC/MS. [CFC's (Chlorofluorocarbons)]	1	N.D.	N.D.
Chlorofluorocarbon-217(CAS No:000422-86-6)	ppm	Analysis was performed by GC/MS. [CFC's (Chlorofluorocarbons)]	1	N.D.	N.D.

Test Item (s):	Unit	Method	MDL	Result	
				No.1	No.2
PCTs(Polychlorinated Terphenyls)	ppm	Analysis was performed by GC/MS or GC/ECD.	0.5	N.D.	N.D.

The content of this PDF file is in accordance with the original issued reports for reference only. This Test Report cannot be reproduced, except in full, without prior written permission of the Company



Test Report

I-PEX JP CO., LTD.

6-27-19 HARAMACHIDA MACHIDA-CITY TOKYO 194-0013
JAPAN

Report No. : CE/2005/61647A

Date : 2005/06/15

Page : 4 of 12

Test Item (s):	Unit	Method	MDL	Result	
				No.1	No.2
Halon		With reference to US EPA 8260.			
Halon-1211(CAS No:000353-59-3)	ppm	Analysis was performed by GC/MS.	1	N.D.	N.D.
Halon-1301(CAS No:000075-63-8)	ppm	Analysis was performed by GC/MS.	1	N.D.	N.D.
Halon-2402(CAS No:000124-73-1)	ppm	Analysis was performed by GC/MS.	1	N.D.	N.D.

Test Item (s):	Unit	Method	MDL	Result	
				No.1	No.2
HCFC's(Hydrogenated chlorofluorocarbons)		With reference to US EPA 8260.			
Hydrochlorofluorocarbon-21(CAS No.:000075-43-4)	ppm	Analysis was performed by GC/MS. [HCFC's (Hydrogenated chlorofluorocarbons)]	1	N.D.	N.D.
Hydrochlorofluorocarbon-22(CAS No.:000075-45-6)	ppm	Analysis was performed by GC/MS. [HCFC's (Hydrogenated chlorofluorocarbons)]	1	N.D.	N.D.
Hydrochlorofluorocarbon-31(CAS No.:000593-70-4)	ppm	Analysis was performed by GC/MS. [HCFC's (Hydrogenated chlorofluorocarbons)]	1	N.D.	N.D.
Hydrochlorofluorocarbon-121(CAS No.:000354-14-3)	ppm	Analysis was performed by GC/MS. [HCFC's (Hydrogenated chlorofluorocarbons)]	1	N.D.	N.D.
Hydrochlorofluorocarbon-122(CAS No.:000354-21-2)	ppm	Analysis was performed by GC/MS. [HCFC's (Hydrogenated chlorofluorocarbons)]	1	N.D.	N.D.
Hydrochlorofluorocarbon-123(CAS No.:000306-83-1)	ppm	Analysis was performed by GC/MS. [HCFC's (Hydrogenated chlorofluorocarbons)]	1	N.D.	N.D.

The content of this PDF file is in accordance with the original issued reports for reference only. This Test Report cannot be reproduced, except in full, without prior written permission of the Company



Test Report

I-PEX JP CO., LTD.

6-27-19 HARAMACHIDA MACHIDA-CITY TOKYO 194-0013
JAPAN

Report No. : CE/2005/61647A

Date : 2005/06/15

Page : 5 of 12

Test Item (s):	Unit	Method	MDL	Result	
				No.1	No.2
Hydrochlorofluorocarbon-124(CAS No.:002837-89-0)	ppm	Analysis was performed by GC/MS. [HCFC's (Hydrogenated chlorofluorocarbons)]	1	N.D.	N.D.
Hydrochlorofluorocarbon-131(CAS No.:000359-28-4)	ppm	Analysis was performed by GC/MS. [HCFC's (Hydrogenated chlorofluorocarbons)]	1	N.D.	N.D.
Hydrochlorofluorocarbon-132b(CAS No.:000471-43-2)	ppm	Analysis was performed by GC/MS. [HCFC's (Hydrogenated chlorofluorocarbons)]	1	N.D.	N.D.
Hydrochlorofluorocarbon-133a(CAS No.:000075-88-7)	ppm	Analysis was performed by GC/MS. [HCFC's (Hydrogenated chlorofluorocarbons)]	1	N.D.	N.D.
Hydrochlorofluorocarbon-141b(CAS No.:001717-00-6)	ppm	Analysis was performed by GC/MS. [HCFC's (Hydrogenated chlorofluorocarbons)]	1	N.D.	N.D.
Hydrochlorofluorocarbon-221	ppm	Analysis was performed by GC/MS. [HCFC's (Hydrogenated chlorofluorocarbons)]	1	N.D.	N.D.
Hydrochlorofluorocarbon-222(CAS No.:000422-30-0)	ppm	Analysis was performed by GC/MS. [HCFC's (Hydrogenated chlorofluorocarbons)]	1	N.D.	N.D.
Hydrochlorofluorocarbon-223	ppm	Analysis was performed by GC/MS. [HCFC's (Hydrogenated chlorofluorocarbons)]	1	N.D.	N.D.
Hydrochlorofluorocarbon-224	ppm	Analysis was performed by GC/MS. [HCFC's (Hydrogenated chlorofluorocarbons)]	1	N.D.	N.D.

The content of this PDF file is in accordance with the original issued reports for reference only. This Test Report cannot be reproduced, except in full, without prior written permission of the Company



Test Report

I-PEX JP CO., LTD.

6-27-19 HARAMACHIDA MACHIDA-CITY TOKYO 194-0013
JAPAN

Report No. : CE/2005/61647A

Date : 2005/06/15

Page : 6 of 12

Test Item (s):	Unit	Method	MDL	Result	
				No.1	No.2
Hydrochlorofluorocarbon-225ca(CAS No.:000422-56-0)	ppm	Analysis was performed by GC/MS. [HCFC's (Hydrogenated chlorofluorocarbons)]	1	N.D.	N.D.
Hydrochlorofluorocarbon-226(CAS No.:000431-87-8)	ppm	Analysis was performed by GC/MS. [HCFC's (Hydrogenated chlorofluorocarbons)]	1	N.D.	N.D.
Hydrochlorofluorocarbon-231	ppm	Analysis was performed by GC/MS. [HCFC's (Hydrogenated chlorofluorocarbons)]	1	N.D.	N.D.
Hydrochlorofluorocarbon-232	ppm	Analysis was performed by GC/MS. [HCFC's (Hydrogenated chlorofluorocarbons)]	1	N.D.	N.D.
Hydrochlorofluorocarbon-233	ppm	Analysis was performed by GC/MS. [HCFC's (Hydrogenated chlorofluorocarbons)]	1	N.D.	N.D.
Hydrochlorofluorocarbon-234	ppm	Analysis was performed by GC/MS. [HCFC's (Hydrogenated chlorofluorocarbons)]	1	N.D.	N.D.
Hydrochlorofluorocarbon-235(CAS No.:013838-16-9)	ppm	Analysis was performed by GC/MS. [HCFC's (Hydrogenated chlorofluorocarbons)]	1	N.D.	N.D.
Hydrochlorofluorocarbon-241	ppm	Analysis was performed by GC/MS. [HCFC's (Hydrogenated chlorofluorocarbons)]	1	N.D.	N.D.
Hydrochlorofluorocarbon-242	ppm	Analysis was performed by GC/MS. [HCFC's (Hydrogenated chlorofluorocarbons)]	1	N.D.	N.D.

The content of this PDF file is in accordance with the original issued reports for reference only. This Test Report cannot be reproduced, except in full, without prior written permission of the Company



Test Report

I-PEX JP CO., LTD.

6-27-19 HARAMACHIDA MACHIDA-CITY TOKYO 194-0013
JAPAN

Report No. : CE/2005/61647A

Date : 2005/06/15

Page : 7 of 12

Test Item (s):	Unit	Method	MDL	Result	
				No.1	No.2
Hydrochlorofluorocarbon-243(CAS No.:000338-75-0)	ppm	Analysis was performed by GC/MS. [HCFC's (Hydrogenated chlorofluorocarbons)]	1	N.D.	N.D.
Hydrochlorofluorocarbon-251	ppm	Analysis was performed by GC/MS. [HCFC's (Hydrogenated chlorofluorocarbons)]	1	N.D.	N.D.
Hydrochlorofluorocarbon-252	ppm	Analysis was performed by GC/MS. [HCFC's (Hydrogenated chlorofluorocarbons)]	1	N.D.	N.D.
Hydrochlorofluorocarbon-253(CAS No.:000354-06-1)	ppm	Analysis was performed by GC/MS. [HCFC's (Hydrogenated chlorofluorocarbons)]	1	N.D.	N.D.
Hydrochlorofluorocarbon-261(CAS No.:000420-97-3)	ppm	Analysis was performed by GC/MS. [HCFC's (Hydrogenated chlorofluorocarbons)]	1	N.D.	N.D.
Hydrochlorofluorocarbon-262(CAS No.:000420-97-3)	ppm	Analysis was performed by GC/MS. [HCFC's (Hydrogenated chlorofluorocarbons)]	1	N.D.	N.D.
Hydrochlorofluorocarbon-271	ppm	Analysis was performed by GC/MS. [HCFC's (Hydrogenated chlorofluorocarbons)]	1	N.D.	N.D.

The content of this PDF file is in accordance with the original issued reports for reference only. This Test Report cannot be reproduced, except in full, without prior written permission of the Company



Test Report

I-PEX JP CO., LTD.

6-27-19 HARAMACHIDA MACHIDA-CITY TOKYO 194-0013
JAPAN

Report No. : CE/2005/61647A

Date : 2005/06/15

Page : 8 of 12

Test Item (s):	Unit	Method	MDL	Result	
				No.1	No.2
PCBs(Polychlorinated Biphenyls)(CAS NO:001336-36-3)	ppm	With reference to USEPA 8082A. Analysis was performed by GC/MS or GC/ECD.	0.5	N.D.	N.D.

Test Item (s):	Unit	Method	MDL	Result	
				No.1	No.2
Polychlorinated Naphthalene	ppm	With reference to 83/264/EEC & EPA 8270D. Analysis was performed by GC/MS.	5	N.D.	N.D.

Test Item (s):	Unit	Method	MDL	Result	
				No.1	No.2
PVC (CAS No:9002-86-2)	**	With reference to ASTM E1252 method. Analysis was performed by FTIR/ATR and Pyro-GC/MS.	-	Negative	Negative

Test Item (s):	Unit	Method	MDL	Result	
				No.1	No.2
Chlorinated Paraffin (C10~C13) (CAS NO:010871-26-2)	%	With reference to USEPA3540C or USEPA3550C. Analysis was performed by GC/MS or GC/ECD.	0.01	N.D.	N.D.

The content of this PDF file is in accordance with the original issued reports for reference only. This Test Report cannot be reproduced, except in full, without prior written permission of the Company



Test Report

I-PEX JP CO., LTD.

6-27-19 HARAMACHIDA MACHIDA-CITY TOKYO 194-0013
JAPAN

Report No. : CE/2005/61647A

Date : 2005/06/15

Page : 9 of 12

Test Item (s):	Unit	Method	MDL	Result	
				No.1	No.2
Halogen		As per EN14582 method B.			
Halogen-Chlorine (Cl)(CAS No:007782-50-5)	ppm	Filling the oxygen and absorb solution in the flask and take sample in the flask and burn it, the absorb solution was analyzed by IC method.	50	N.D.	N.D.
Halogen-Fluorine (F)(CAS No:007782-41-4)	ppm	Filling the oxygen and absorb solution in the flask and take sample in the flask and burn it, the absorb solution was analyzed by IC method.	50	N.D.	3410.0
Halogen-Bromine (Br)(CAS No:007726-95-6)	ppm	Filling the oxygen and absorb solution in the flask and take sample in the flask and burn it, the absorb solution was analyzed by IC method.	50	N.D.	74650.0
Halogen-Iodine (I)(CAS No:007553-56-2)	ppm	Filling the oxygen and absorb solution in the flask and take sample in the flask and burn it, the absorb solution was analyzed by IC method.	50	N.D.	N.D.

Test Item (s):	Unit	Method	MDL	Result	
				No.1	No.2
Methyl chloroform(CAS No.:000071-55-6)	ppm	With reference to US EPA 8260. Analysis was performed by GC/MS linked Headspace.(CFC's(Chlorofluorocarbons))	1	N.D.	N.D.

The content of this PDF file is in accordance with the original issued reports for reference only. This Test Report cannot be reproduced, except in full, without prior written permission of the Company



Test Report

I-PEX JP CO., LTD.

6-27-19 HARAMACHIDA MACHIDA-CITY TOKYO 194-0013
JAPAN

Report No. : CE/2005/61647A

Date : 2005/06/15

Page : 10 of 12

Test Item (s):	Unit	Method	MDL	Result	
				No.1	No.2
Monobromobiphenyl	%	With reference to USEPA3540C or USEPA3550C. Analysis was performed by HPLC/DAD, LC/MS or GC/MS. (prohibited by 2002/95/EC (RoHS), 83/264/EEC, and 76/769/EEC)	0.0005	N.D.	N.D.
Dibromobiphenyl	%		0.0005	N.D.	N.D.
Tribromobiphenyl	%		0.0005	N.D.	N.D.
Tetrabromobiphenyl	%		0.0005	N.D.	N.D.
Pentabromobiphenyl	%		0.0005	N.D.	N.D.
Hexabromobiphenyl	%		0.0005	N.D.	N.D.
Heptabromobiphenyl	%		0.0005	N.D.	N.D.
Octabromobiphenyl	%		0.0005	N.D.	N.D.
Nonabromobiphenyl	%		0.0005	N.D.	N.D.
Decabromobiphenyl	%		0.0005	N.D.	N.D.
Total PBBs (Polybrominated biphenyls)/Sum of above	%	-	N.D.	N.D.	
Monobromobiphenyl ether	%	With reference to USEPA3540C or USEPA3550C. Analysis was performed by HPLC/DAD, LC/MS or GC/MS. (prohibited by 2002/95/EC (RoHS), 83/264/EEC, and 76/769/EEC)	0.0005	N.D.	N.D.
Dibromobiphenyl ether	%		0.0005	N.D.	N.D.
Tribromobiphenyl ether	%		0.0005	N.D.	N.D.
Tetrabromobiphenyl ether	%		0.0005	N.D.	N.D.
Pentabromobiphenyl ether	%		0.0005	N.D.	N.D.
Hexabromobiphenyl ether	%		0.0005	N.D.	N.D.
Heptabromobiphenyl ether	%		0.0005	N.D.	N.D.
Octabromobiphenyl ether	%		0.0005	N.D.	N.D.
Nonabromobiphenyl ether	%		0.0005	N.D.	N.D.
Decabromobiphenyl ether	%		0.0005	N.D.	N.D.
Total PBDEs(PBDEs)(Polybrominated biphenyl ethers)/Sum of above	%	-	N.D.	N.D.	

The content of this PDF file is in accordance with the original issued reports for reference only. This Test Report cannot be reproduced, except in full, without prior written permission of the Company



Test Report

I-PEX JP CO., LTD.

6-27-19 HARAMACHIDA MACHIDA-CITY TOKYO 194-0013
JAPAN

Report No. : CE/2005/61647A

Date : 2005/06/15

Page : 11 of 12

Test Item (s):	Unit	Method	MDL	Result	
				No.1	No.2
Chromium VI (Cr+6)	ppm	UV-VIS after reference to US EPA 3060A.	2	N.D.	N.D.
Cadmium (Cd)	ppm	ICP-AES after as per EN 1122, method B:2001 or other acid digestion.	2	N.D.	N.D.
Mercury (Hg)	ppm	ICP-AES after as per US EPA 3052 or other acid digestion.	2	N.D.	N.D.
Lead (Pb)	ppm	ICP-AES after as per US EPA 3050B or other acid digestion.	2	22.1	14.7

- NOTE: (1) N.D. = Not detected (<MDL)
(2) ppm = mg/kg
(3) MDL = Method Detection Limit
(4) " - " = No Regulation
(5) " --- " = Not Applicable
(6) * = Results shown are of the adjusted analytical results
(7) ** = Qualitative analysis (No Unit)
(8) Negative = Undetectable / Positive = Detectable
(9) The MDL is 5ppm for the single compound of CP

Test Report

I-PEX JP CO., LTD.

6-27-19 HARAMACHIDA MACHIDA-CITY TOKYO 194-0013
JAPAN

Report No. : CE/2005/61647A

Date : 2005/06/15

Page : 12 of 12





Certification

Awarded to

FULL RISE ELECTRONIC CO., LTD.

NO. 26, KAO CHING ROAD, KAO SHAN LI, YANG MEI, TAOYUAN

TAIWAN, R.O.C.

BVQi certify that the Management System of the above organisation has been audited and found to be in accordance with the requirements of the management system standards detailed below

STANDARD

ISO 9001:2000

Scope of supply

Design, manufacture and supply the following :

- 1.PCB modular jack and plugs.
- 2.Telecom accessories C3, C4, C5, C5e, C6.
- 3.PC & IA connectors,
- 4.Card and board to board connectors
- 5.Wireless passive components
- 6.Mobile phone connectors.
- 7.Transformer jack

Original Approval Date: **3 March, 1998**

Subject to the continued satisfactory operation of the organisation's Management System, this certificate is valid until: **31 March, 2008**

To check the validity of this certificate please call (886-2-25707656)

Further clarification regarding the scope of this certificate and the applicability of the management system requirements may be obtained by consulting the organisation

Certificate Number: **172475** Date: **21 April, 2004** **Sandy Chen**



008

Managing office : BVQi(Holding) S.A. 2nd Floor, Tower Bridge Court, 224-226 Tower Bridge Road, London, SE1 2TX, England
Issuing office : BVQi (Taiwan) Co., Ltd. 6th Floor, No. 3, Tun Hua S. Rd., Sec. 1, Taipei, Taiwan, R. O. C.

For BVQi (Holding) S. A
Using the accreditation
certification number 008

