



INSTALLATION & SERVICE
MANUAL

MODEL H100
CONTINUOUS DUTY
POWER AMPLIFIER

450-470 MHz

May 17, 2000

Crescend Technologies
2255 Lois Drive, Suite 1
Rolling Meadows, IL 60008

Tel: 847 593 1213
Fax: 847 593 1320
Web Site: www.crescendtech.com

TABLE OF CONTENTS		
Par.	Section 1	Page
No.	General Description	No.
1-1	Introduction	4
1-2	General Description	4
1-3	Functional and Physical Specifications	4
1-4	Equipment Changes	4
1-5	Ordering Information	4
Section 2		
Installation		
2-1	Introduction	6
2-2	Electrical Service Recommendations	6
2-3	Unpacking and Inspection	6
2-4	Installation Instructions	6
2-5	Amplifier Module Alarm and Control Connector	7
Section 3		
Operating Instructions		
3-1	Introduction	8
3-2	Location and Function of Amplifier Module Control and Indicators	8
3-3	Initial Start-Up and Operating Procedures	8
3-4	Variable Input Switch	9
Section 4		
Principles of Operation		
4-1	Introduction	10
4-2	RF Input Signal	10
4-3	RF Output Load	10
4-4	Functional Description	10
4-5	H100 Amplifier Module	10
4-5.1	Main Amplifier	10
4-5.2	Loop Control	11
4-5.3	Amplifier Monitoring	11
4-5.4	Amplifier Module Cooling	11
4-6	Power Distribution	11

TABLE OF CONTENTS (Continued)

Section 5 Maintenance

5-1	Introduction	12
5-2	Periodic Maintenance	12
5-3	Test Equipment Required for Test	12
5-4	Cleaning air Inlets/Outlets	13
5-5	Performance Test	13
5-5.1	Amplifier Performance Test	13
5-6	Field Replaceable Parts and Modules	14
5-6.1	H100 Power Amplifier Module	14
5-6.2	Cooling Fans	14
5-6.3	Fuse	15

Section 6 Troubleshooting

6-1	Introduction	16
6-2	Troubleshooting	16
6-3	Return for Service Procedure	16
6-3.1	Obtaining an RMA	16
6-3.2	Repackaging for Shipment	16

Figure	LIST OF ILLUSTRATIONS	Page
4-1	Variable Input Switch	10
4-2	H100 Block Diagram	11
5-1	Amplifier Test Setup diagram	15

LIST OF TABLES Table Page

1-1	Major Amplifier Components	4
1-2	H100 Amplifier Functional Specifications	5
1-3	Load Mismatch Tolerance	5
2-1	Amplifier Module Alarm and Control Connections	7
3-1	H100 Amplifier Module Control and Indicators	8
5-1	Periodic Maintenance	12
5-2	Test Equipment Required	12
6-1	Troubleshooting	16

1. GENERAL DESCRIPTION

1.1. INTRODUCTION

This manual contains information and procedures for installation, operation, of Crescend's H100 Continuous Duty Power Amplifier. The manual is organized into five sections as follows:

- Section 1. General Description
- Section 2. Installation
- Section 3. Operating Instructions
- Section 4. Principles of Operation
- Section 5. Maintenance
- Section 6: Troubleshooting

1.2. GENERAL DESCRIPTION

The H100 amplifier is designed for trunking and conventional repeater applications requiring high duty cycles. The H100 amplifier operates from RF power sources of 250 milliwatts up to 25 watts. The amplifier consists of an input attenuator, a predriver amplifier, a microprocessor circuit control, and two stages of amplification followed by a 7-pole distributed low-pass filter and associated control circuitry. The H100 amplifier has a microprocessor control board that maintains a constant output power under varying signal input and output load conditions. A system functional block diagram of the Model H100 amplifier is contained in section 4 of this manual.

1.3. FUNCTIONAL AND PHYSICAL SPECIFICATIONS

Functional and physical specifications for the H100 amplifier are listed in tables 1-2 and 1-3.

1.4. EQUIPMENT CHANGES

Crescend Technologies, Inc. reserves the right to make minor changes without notice, including but not necessarily limited to component substitution and circuitry changes. Such changes may or may not be incorporated in this manual, although it is our intention to keep each manual as up-to-date as possible. To that end, we ask that you, our customer, share with us information acquired in field situations which might be of assistance to another user. If you share it with us, we'll pass it around.

1.5. ORDERING INFORMATION

Table 1-1 following gives the part numbers and descriptions to be used when ordering either an entire amplifier or replacement fans.

Table 1-1. Major Amplifier Components

MODEL NUMBER	DESCRIPTION
H100	250 mW – 25 W 450-470 MHz Amplifier
800-00889-001	Fan Assembly

Table 1-2. H100 Amplifier Functional Specifications

Frequency Range:	450-470 MHz.
Operating Voltage:	+28 Vdc (± 1.0 Vdc)
Current Draw	9 Amperes Typical; 11 Amperes Maximum
Duty Cycle:	100%
Power Input:	250 mW - 25 W.
Power Output:	100 Watts
Spurious & Harmonics.	-70 dBc (Minimum)
Input/Output Impedance	50 ohms (Nominal)
Load VSWR Tolerance	See Chart
Input/Output Connector:	Type N Female
Vertical Mounting:	10.47"
Horizontal Mounting:	3.38'
Depth.	17.0"
Weight:	20 Pounds Nominal
Cooling Method:	Fan Forced Air Over Heatsink
Operating Temp. Range:	0 °C. to +60 °C.
Storage & Transport:	-10 °C. to +70 °C.
Humidity:	80% at +40 °C. (Non condensing)
Altitude:	10,000 Feet Maximum
OPTIONS	
Remote Control/Display Panel	<p>INDICATORS DC PWR ON, LOW OUTPUT, LOW INPUT, HIGH INPUT, HIGH VSWR, OVER TEMP., L.E.D. POWER BAR METER</p> <p>CONTROLS PWR CONTROL (-10 dB)</p>

NOTES: Manufacturer's Rated Output Power of this Equipment is for Single Carrier Operation.

All specifications apply at +28 Vdc operating voltage.

Table 1-3. Load Mismatch Tolerance

Full Power, Sustained Operation	2:1 Maximum
Sustained Operation at Reduced Power	3:1
Microprocessor Shutdown	10:1

2. INSTALLATION

2.1. INTRODUCTION

This section contains installation recommendations, unpacking, inspection, and installation instructions for the H100 amplifier. Carefully read all material in this section prior to equipment unpacking or installation. Also read and review the operating procedures in Section 3 prior to installing the equipment. It is important that the licensee perform these tasks correctly and in good faith. If applicable, carefully read Parts 73 and 74 of the Federal Communications Commission (FCC) rules to determine how they apply to your installation. DON'T TAKE CHANCES WITH YOUR LICENSE.

2.2. ELECTRICAL SERVICE RECOMMENDATIONS

Crescend Technologies recommends that proper AC line conditioning and surge suppression be provided on the primary AC input to the +28 Vdc power source. All electrical service should be installed in accordance with the National Electrical Code, any applicable state or local codes, and good engineering practice. Special consideration should be given to lightning protection of all systems in view of the vulnerability of most transmitter sites to lightning. Lightning arrestors are recommended in the service entrance. Straight, short ground runs are recommended. The electrical service must be well grounded.

Each amplifier system should have its own circuit breaker, so a failure in one does not shut off the whole installation. Circuit breakers should be thermal type, capable of handling an inrush current of 90 Amps, in a load center with a master switch.

2.3. UNPACKING AND INSPECTION

This equipment has been operated, tested and calibrated at the factory. Only in the event of severe shocks or other mistreatment should any substantial readjustment be required. Carefully open the container(s) and remove the amplifier module(s). Retain all packing material that can be reassembled in the event that the unit must be returned to the factory.

CAUTION: Exercise care in handling equipment during inspection to prevent damage caused by rough or careless handling.

Visually inspect the amplifier module for damage that may have occurred during shipment. Check for evidence of water damage, bent or warped chassis, loose screws or nuts, or extraneous packing material in the connector or fans. Inspect the rear panel connector for bent connector pins. If the equipment is damaged, a claim should be filed with the carrier once the extent of any damage is assessed. We cannot stress too strongly the importance of IMMEDIATE careful inspection of the equipment and the subsequent IMMEDIATE filing of the necessary claims against the carrier if necessary. If possible, inspect the equipment in the presence of the delivery person. If the equipment is damaged, the carrier is your first area of recourse. If the equipment is damaged and must be returned to the factory, write or phone for a return authorization. Crescend may not accept returns without a return authorization. Claims for loss or damage may not be withheld from any payment to Crescend, nor may any payment due be withheld pending the outcome thereof. WE CANNOT GUARANTEE THE FREIGHT CARRIER'S PERFORMANCE.

2.4. INSTALLATION INSTRUCTIONS

The H100 amplifier module is designed for installation in a sub rack that permits access to the rear of the sub rack for connection of DC power, RF, and monitor cables.

To install the amplifier proceed as follows:

1. Install sub rack in equipment rack and secure in place.
2. Install the plug-in H100 amplifier module(s) in the sub rack. Tighten top and bottom thumbscrews.
3. Connect 50-ohm antenna cable to RE OUT connector on rear of amplifier module.

4. Connect the transceiver/exciter output to RF IN connector on rear of amplifier module.
5. Connect alarm and control cable to 9-pin D-sub connector on rear of amplifier module. Refer to paragraph 2-5 for connector definition.

WARNING: Turn off external primary DC power before connecting DC power cables.

6. Connect positive primary power to +28V terminal and negative primary power to GND terminal on rear of amplifier module. Tighten the power connections.
7. Check your work before applying DC voltage to the system. Make certain all connections are tight and correct.
8. Measure primary DC input voltage. DC input voltage should be +28 Vdc \pm .0 Vdc. If the DC input voltage is above or below the limits, call and consult Crescend before you turn on your amplifier system.
9. Refer to section 3 for initial turn -on and checkout procedures.

2.5. AMPLIFIER MODULE ALARM AND CONTROL CONNECTOR

The alarm and control connections on the amplifier are made through a female 9-pin D-sub connector and are listed and described in table 2-1.

Table 2-1. Alarm and Control Connector Pins (on Rear of H100 Module)

PIN NUMBER	FUNCTION	DESCRIPTION
1	Low Input Power	Indicates alarm when input drive is approximately 2.5 dB below specified range
2	GND	System Ground
3	Over Temperature	Indicates alarm if junction temperature exceeds 60 °C
4	VSWR	Indicates alarm for VSWR >3:1
5	Fwd Detect Vdc	Input drive range set
6	External Reset	Resets microprocessor after alarm condition is set
7	DC Power	Indicates alarm condition when 24 Vdc > power supply > 30 Vdc
8	RF Output Status	Indicates alarm if an output transistor fails
9	Not used	No connection

3. OPERATING INSTRUCTIONS

3.1. INTRODUCTION

This section contains operating instructions for the H100 Amplifier.

3.2. LOCATION AND FUNCTION OF AMPLIFIER MODULE CONTROL AND INDICATORS.

The location and function of the H100 amplifier module control and indicators is described in detail in table 3-1.

Table 3-1. H100 Amplifier Module Control and Indicators

NO	NAME	FUNCTION
1	DC PWR ON Indicator	Green LED. Continuous illumination at voltages from 26-29.9 Vdc (this is the acceptable operating range for the H100 amplifier). At DC voltages from 24-25.9 Vdc, the LED will flash and the output power will remain at its specified level. At voltages less than 24 and greater than 30 Vdc, the H100 will shut down, and the DC POWER ON LED will flash.
2	LOW OUTPUT Indicator	Red LED. Activates when. 1. The op amp in the automatic gain control becomes saturated at its rails, or 2. One of the finals in the amplifier becomes faulty.
3	LOW INPUT Indicator	Red LED. Activates when input drive to the H100 drops by 1.5 dB from its rated input drive. At this point, the led will flash, but the output will remain at its rated power. Should the RF input drive drop by another 1 dB, the LED will illuminate continuously and there will be no output from the H100 amplifier.
4	HIGH INPUT indicator	Red LED. Activates when input drive to the H100 is increased by 1.5 dB from its rated input drive. At this point, the led will flash, but the output will remain at its rated power. Should the RF input drive increase by another 1 dB, the LED will illuminate continuously and there will be no output from the H100 amplifier
5	HIGH VSWR Indicator	Red LED. Activates at loads greater than 3:1. At this point, the amplifier output will drop by -3dB. Should the output load open (VSWR >10:1) The indicator will still be lit and there will be no output from the amplifier.
6	OVER TEMP Indicator	Red LED. Activates when the heatsink of the amplifier exceed 63 degrees Celsius. At this point, the H100 amplifier will shut down, and there will be no output. When the amplifier has sufficiently cooled, the H100 will resume normal operation.
7	PWR CONTROL Adjustment	Allows user to reduce the power output by more than 10 dB below the factory-set 100 watts.
8	POWER Indicator	Output LED bar level indicator. Each bar represents 10 watts of output power.

3.3. Initial Startup

To perform the initial start-up, proceed as follows:

Double-check to ensure that all input and output cables are properly connected.

CAUTION: Before applying power, make sure that the input and output of the amplifier are properly terminated at 50 ohms. Do not operate the amplifier without a load attached. Refer to table 1 -2 for input power requirements. Excessive input power may damage the amplifier.

NOTE: The output coaxial cable between the amplifier and the antenna must be 50-ohm coaxial cable. Use of any other cable will distort the output.

2. Verify that power supply measures 28 ± 1 Vdc. Apply power to the amplifier(s). Do not apply a RF signal to the amplifier system.
3. Visually check the indicators on each amplifier module, and verify the following:
 - a. The DC PWR ON indicator (green) on all amplifier modules should be on.
 - b. The LOW INPUT indicator (red) on all amplifier modules should be on.
4. Turn on external exciter/transceiver and apply RF input signals. All red LEDs should turn off within 2 5 seconds.

3.4. VARIABLE INPUT SWITCH

If the RF input to the H100 amplifier should change, figure 4-1 shows which DIP switch to activate for various inputs. A trained technician, with prior approval and instructions from Crescend's service department, should only perform this. Failure to receive prior permission to open the amplifier could void the warranty.

1. Verify that no DC or RF is applied to the H100.
2. If necessary, remove H100 from sub rack.
3. Remove the lid from the H100.
4. Locate the variable toggle switch (S1) on the 500 -00800-001 driver PCB.
5. Refer to figure 4-1 for various switch settings.

4. PRINCIPLES OF OPERATION

4.1. INTRODUCTION

This section contains a functional description of the H100 Amplifier.

4.2. RF INPUT SIGNAL

H100 amplifiers are equipped with an input variable switch that ranges from 250m W to 25W (see figure 4-1). They have a predriver module that consists of an input attenuator pad, variable input attenuator, and a power amplifier module that provides up to 13dB of gain. The microprocessor uses detector circuitry to maintain a constant output level by sensing RF input, output, VSWR, temperature, and driver/final failures. Input VSWR to the H100 should not exceed 2:1 for best performance.

Input Power Range 1: 0.25 –0.5 watts

Input Power Range 2: 0.5-1.0 watts

Input Power Range 3: 1-2 watts

Input Power Range 4: 2-4 watts

Input Power Range 5: 4 .8 watts

Input Power Range 6: 8 .16 watts

Input Power Range 7: 16 .25 watts

Input Power Range 8: Not Used

Figure 4-1. Variable Input Switch

4.3. RF OUTPUT LOAD

The load impedance should be as good as possible (2:1 or better) in the working band for good power transfer to the load.

4.4. FUNCTIONAL DESCRIPTION

The H100 amplifier (see block diagram figure 4-2) is a linear, single channel amplifier that operates in the frequency band from 450 MHz to 470 MHz. The amplifier specifications are listed in table 1-2. Each amplifier is a self-contained plug-in module and is functionally independent of other amplifier modules. The amplifier modules are designed for parallel operation to achieve high peak power output, and for redundancy in unmanned remote locations. Each amplifier in the system can simultaneously transmit carrier frequencies, at an average total power output of 100 watts.

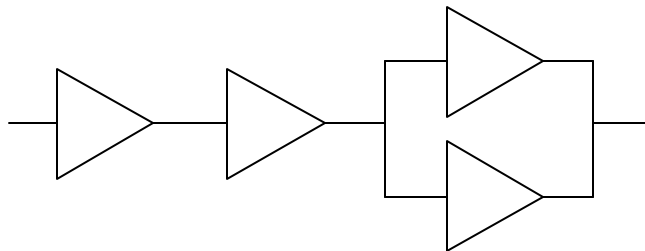

Figure 4-2. H100 Block Diagram

4.5. H100 AMPLIFIER MODULE

The amplifier module has an output of 100 watts power with all harmonics suppressed to better than -

70 dBc below carrier level. The amplifier module is comprised of:

- Microprocessor board/alarm monitoring
- Pre-driver board/splitter
- Two final gain stages
- Alarm monitoring, control, and display panel
- Distributed low pass filter board/ combiner board

4.5.1. MAIN AMPLIFIER

The input and output of the amplifier employ three -stage, class AB amplifiers which provide approximately 54 dB of gain in the 20 MHz frequency band from 450 MHz to 470 MHz. The amplifier operates on +28 Vdc, and a bias voltage of +6 Vdc, and is mounted directly on a heat sink. The alarm logic controls the +6 Vdc bias voltage that shuts down the amplifier.

4.5.2. LOOP CONTROL

The loop control circuitry consists of a microprocessor (see paragraph 4-2), which prevents the RF output and input power from exceeding the safe operating maximum power levels.

The RF output power from the model H100 amplifier is controlled by the microprocessor. A coupled detector on the low-pass filter PCB monitors the final RF output level and generates a DC voltage (VFWD) proportional to the RF output level. VFWD is fed back to the microprocessor. The microprocessor compares this voltage to a reference voltage, and varies the output gain of the driver module to maintain a constant 100-watt output. The microprocessor also provides over-temperature protection for the amplifier. All RE modules in the amplifier are mounted on a common heatsink. The modules all have temperature-sensing ICs mounted on them, which constantly monitor heat and convert it to a DC voltage. This voltage is sent to the microprocessor which shuts down the amplifier should temperatures exceed 63 degrees Celsius. When the amplifier has sufficiently cooled down, the microprocessor re-enables the amplifier.

The output of the driver amplifier, approximately five watts of power, is fed to a 2-way power splitter, amplified by the two parallel final amplifier modules, then combined and fed to the 7 -pole distributed low-pass filter. The filter attenuates any spurious and harmonic signals that may have been produced by the various gain stages, for a final RE output of 100 watts. Double-shielded Teflon cable is used for all high power RF interconnections.

4.5.3. AMPLIFIER MONITORING

In the main amplifier modules, all normal variations are automatically compensated for by the microprocessor. However, when large variations occur beyond the adjustment range of the loop control, a low output alarm will occur. The alarms are displayed in the front panel indicators.

Status indicators on the front panel include DC PWR ON, LOW OUTPUT, LOW INPUT, HIGH INPUT, HIGH VSWR, and OVER-TEMP. AN RF power-level adjustment potentiometer is also provided on the front panel. The power adjustment allows the user to reduce the power output by more than 10 dB below the factory-set 100-watt output. An output LED bar level indicator is also provided on the H100. Each bar represents 10 watts of output power.

4.5.4. AMPLIFIER MODULE COOLING

Although each amplifier module contains its own heat sink, it is cooled with forced air. Two fans are used for forced air-cooling and redundancy. The fans located on the rear of the amplifier module and operating continuous duty from applied DC, draw ambient air in through the front of the amplifier and exhaust hot air out the rear of the module. The fans are field replaceable.

4.6. POWER DISTRIBUTION

Primary DC power for the system is provided by the host system. This system supplies each amplifier module with +28 Vdc directly via a 15-amp fuse located on the rear panel of the amplifier. The amplifier module has a DC/DC converter that converts the +28 Vdc to +6 Vdc to provide bias.

5. MAINTENANCE

5.1. INTRODUCTION

This section contains periodic maintenance and performance test procedures for the Kb. It also contains a list of test equipment required to perform the identified tasks.

NOTE: Check your sales order and equipment warranty before attempting to service or repair the unit. Do not break the seals on equipment under warranty or the warranty will be null and void. Do not return equipment for warranty or repair service until proper shipping instructions are received from the factory.

5.2. PERIODIC MAINTENANCE

Periodic maintenance requirements are listed in Table 5-1. Table 5-1 also lists the intervals at which the tasks should be performed.

WARNING: Wear proper eye protection to avoid eye injury when using compressed air.

Table 5-1. Periodic Maintenance

TASK	INTERVAL	ACTION
Cleaning Air Vents	30 Days	Inspect and clean per paragraph 5-4
Inspection Cables and Connectors	12 Months	Inspect signal and power cables for frayed insulation. Check RF connectors to be sure that they are tight.
Performance Tests	12 Months	Perform annual test per paragraph 5-5.

5.3. TEST EQUIPMENT REQUIRED FOR TEST

Test equipment required to test the amplifier system is listed in Table 5-2. Equivalent test equipment may be substituted for any item.

NOTE: All RF test equipment must be calibrated to 0.05 dB resolution. Any deviation from the nominal attenuation must be accounted for and factored into all output readings.

Table 5-2. Test Equipment Required

NOMENCLATURE	MANUFACTURER	MODEL
Signal Generator	H.P.	8648B
40 dB Attenuator, 250 Watt	Tenuline	
DC power supply	H.P.	6269B
Spectrum Analyzer	H.P.	8560E
Dual Directional Coupler	Narda	
Power Meter / Sensor	H.P.	437B / 8481A
Linear Discreet Amplifier		
Digital Multi-Meter	Fluke	73
Current Probe		

5.4. CLEANING AIR INLETS/OUTLETS

The air inlets and outlets should be cleaned every 30 days. If the equipment is operated in a severe dust environment, they should be cleaned more often as necessary. Turn off DC power source before removing fans. If dust and dirt are allowed to accumulate, the cooling efficiency may be diminished. Using either compressed air or a brush with soft bristles, loosen and remove accumulated dust and dirt from the air inlet panels.

5.5. PERFORMANCE TEST

Performance testing should be conducted every 12 months to ensure that the amplifier system meets the operational specifications listed in table b -2. Also verify system performance after any amplifier module is replaced in the field. The test equipment required to perform the testing is listed in table 5-2, and the test setup is shown in figure 5-1.

NOTE: The frequencies used in this test are typical for an amplifier with a band from 450 MHz to 470 MHz.

5.5.1. AMPLIFIER PERFORMANCE TEST.

This test is applicable to a sub rack equipped with one to five plug-in H100 amplifier modules. Perform the tests applicable to your system. To perform the test, proceed as follows:

Connect test equipment as shown in figure 5-1.

NOTE: Do not apply any RF signals at this time.

Turn on DC (28 V). Turn on signal generator and set frequency to 860 MHz.

5.5.2. HARMONICS TEST

With the power amplifier set at 100 watts power output, use the spectrum analyzer and check the frequency band from 450 MHz to 470 MHz for harmonics. Harmonics should be -70 dBc maximum.

5.5.3. SPURIOUS TEST

With the power amplifier set at 100 watts power output, use the spectrum analyzer and check the frequency band from 450 MHz to 470 MHz for spurious signals. Spurious signals should be -70 dBc maximum.

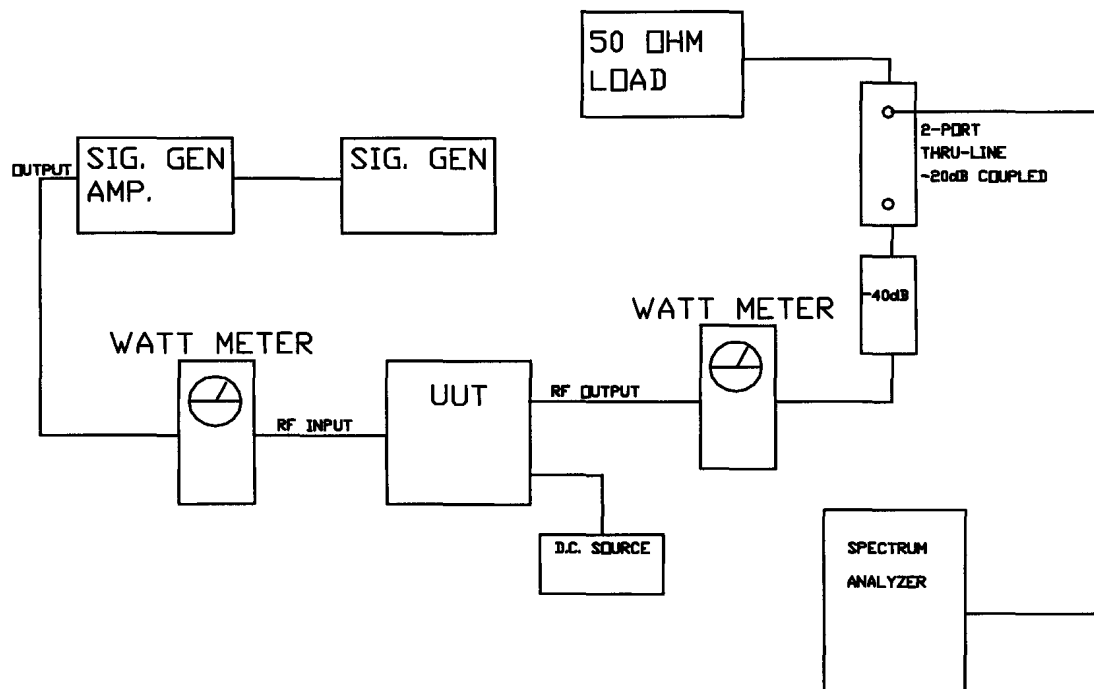

Figure 5-1. Amplifier Test Setup Diagram

5.5.4. GAIN TEST:

Disconnect spectrum analyzer from test setup, and connect the power meter.

Apply the rated input RF drive to the H100. Verify that the unit delivers 100 W out for rated input

5.6. FIELD REPLACEABLE PARTS AND MODULES

The following parts and modules can be replaced in the field on site by a qualified technician with experience maintaining RF power amplifiers and similar equipment:

5.6.1. H100 POWER AMPLIFIER MODULE

To replace a H100 module, proceed as follows

1. Loosen two thumbscrews that secure amplifier module to sub rack.

CAUTION: When removing the amplifier from the sub rack, it is very important to support the amplifier such that the rear of the module does not suddenly drop when the guide rail disengages from the track. A drop such as this could damage the rear of the amplifier.

2. Use the handles on the front of the module, and with a steady even pressure, pull the module out of chassis.

5.6.2. COOLING FANS

To replace a cooling fan, proceed as follows.

1. Remove amplifier module from sub rack.
2. Loosen three screws that secure fan to amplifier module. Disconnect fan power connector from amplifier module.
3. Install replacement fan in reverse order of steps 1 and 2 above.

5.6.3. FUSE

The H100 amplifier 28 Vdc power input line contains a single fuse as follows:

Manufacturer:	Littlefuse
Manufacturer's Number:	313015
Rating:	15 amps
Style	3AG Slo-Blo
Size:	1/4 inch diameter
	1-1/4 inches long

6. TROUBLE SHOOTING

6.1. INTRODUCTION

This section contains a list of problems, which users have encountered, and a few suggested actions that may correct the problem. If the suggested corrective action does not eliminate the problem, please contact your Crescend field representative or the factory for further instructions.

NOTE: Check your sales order and equipment warranty before attempting to service or repair the unit. Do not break the seals on equipment under warranty or the warranty will be null and void. Do not return equipment for warranty or repair service until proper shipping instructions are received from the factory.

6.2. TROUBLESHOOTING

Refer to table 6-1 for troubleshooting suggestions.

Table 6-1. Troubleshooting.

SYMPTOM	SUGGESTED ACTION
Any voltage indicators (green) are <u>not lit</u> or blinking	Check that subrack power connection is secure. Check for proper power supply voltage. Check fuses or circuit breakers on amplifier or subrack. Verify that amplifier is fully inserted into subrack.
OVER TEMP alarm (red) is lit	Verify fan(s) are operating properly. Check ambient temperature (not to exceed spec - see table 1-2)
HIGH/LOW INPUT alarm (red) is lit	Verify RF input level does not exceed spec - see table 1-2
HIGH VSWR alarm (red) is lit	Check output connections and cables for integrity and tightness
LOW OUTPUT alarm (red) is lit	Contact Crescend field representative or factory.

6.3. RETURN FOR SERVICE PROCEDURES

When returning products to Crescend, the following procedures will ensure optimum response.

6.3.1. Obtaining an RMA

A Return Material Authorization (RMA) number must be obtained prior to returning equipment to the factory for service. Please contact our Customer Service Department at (847) 593-1213 to obtain this number. Failure to obtain this RMA number will result in considerable delays in receiving repair service.

6.4. Repackaging for Shipment

To ensure safe shipment of the amplifier, it is recommended that the package designed for the amplifier be used. The original packaging material is reusable. If it is not available, contact Crescend's Customer Service Department for packing materials and information.