



849 NW STATE ROAD 45
NEWBERRY, FL 32669 USA
PH: 888.472.2424 OR 352.472.5500
FAX: 352.472.2030
EMAIL: INFO@TIMCOENGR.COM
[HTTP://WWW.TIMCOENGR.COM](http://WWW.TIMCOENGR.COM)

FCC PT 90 AMPLIFIER AND IC RSS-131, RSS-GEN TEST REPORT

APPLICANT	CRESCEND TECHNOLOGIES, LLC
ADDRESS	920 EAST STATE PARKWAY SCHAUMBURG IL 60173 USA
FCC ID	CWWP8XXL1
IC LABEL	7291A-P8XXL1
MODEL NUMBER	P8 SERIES 900
PRODUCT DESCRIPTION	Amplifier
DATE SAMPLE RECEIVED	6/11/2010
DATE TESTED	7/9/2010
TESTED BY	Nam Nguyen
APPROVED BY	Mario de Aranzeta
TIMCO REPORT NO.	1396AT10TestReport.pdf
TEST RESULTS	<input checked="" type="checkbox"/> PASS <input type="checkbox"/> FAIL

**THE ATTACHED REPORT SHALL NOT BE REPRODUCED EXCEPT IN FULL
WITHOUT THE WRITTEN APPROVAL OF TIMCO ENGINEERING, INC.**



Certificate # 0955-01



TABLE OF CONTENTS

ATTESTATION STATEMENT	3
REPORT SUMMARY	4
TEST ENVIRONMENT AND TEST SETUP	4
DUT DESCRIPTION	5
TEST EQUIPMENT	6
TEST PROCEDURES	7
TEST RESULTS	9
RF POWER OUTPUT	9
OCCUPIED BANDWIDTH	13
SPURIOUS EMISSIONS AT ANTENNA TERMINALS (CONDUCTED)	14
FIELD STRENGTH OF SPURIOUS EMISSIONS (RADIATED).....	15
POWER LINE CONDUCTED INTERFERENCE	16

Applicant: Crescend Technolgoies LLC
FCC ID: CWWP8XXL1
IC: 7291A-P8XXL1
MODEL #: P8 SERIES 900
Report: Z:\C\CRESCEND_CWW\1396AT10\Extra1396AT10\1396AT10TestReport.doc

ATTESTATION STATEMENT

This equipment has been tested in accordance with the standards identified in the referenced test report. To the best of my knowledge and belief, these tests were performed using the measurement procedures described in this report.



Test Certificate #0955-01

All instrumentation and accessories used to test products for compliance to the indicated standards are calibrated regularly in accordance with ISO 17025 requirements.

I attest that the necessary measurements were made by me or under my supervision, at Timco Engineering, Inc. located at 849 N.W. State Road 45, Newberry, Florida 32669 USA.

Authorized by: Mario de Aranzeta



Signature:

Function: Test Lab Supervisor / Engineer

Date: 9/15/2010

Applicant: Crescend Technolgoies LLC
FCC ID: CWWP8XXL1
IC: 7291A-P8XXL1
MODEL #: P8 SERIES 900
Report: Z:\C\CRESCEND_CWW\1396AT10\Extra1396AT10\1396AT10TestReport.doc



REPORT SUMMARY

Disclaimer	The test results relate only to the items tested.
Purpose of Test	To show the DUT in compliance with FCC CFR 47, Part 90 and IC RSS-131 requirements for amplifiers
Test Procedures	ANSI/TIA 603-C: 2004 FCC CFR 47 Part 90 IC RSS-131 ANSI C63.4: 2003
Related Approval	N/A

TEST ENVIRONMENT AND TEST SETUP

Test Facility	All tests were conducted by Timco Engineering Inc. located at 849 NW State Road 45, Newberry, FL 32669 USA
Laboratory Test Condition	Temperature: 26°C Relative humidity: 50%.
Deviation from the standards	No deviation
Modification to the DUT	No modification was made.
Test Exercise (software etc.)	The DUT was placed in continuous transmitting mode of operation.
System Setup	Stand alone device.

Applicant: Crescend Technolgoies LLC
 FCC ID: CWWP8XXL1
 IC: 7291A-P8XXL1
 MODEL #: P8 SERIES 900
 Report: Z:\C\CRESCEND_CWW\1396AT10\Extra1396AT10\1396AT10TestReport.doc



DUT DESCRIPTION

Manufactured by	Crescend Technologies, LLC
Product Description	Amplifier
FCC ID	CWWP8XXL1
IC Label	7291A-P8XXL1
M/N	P8 SERIES 900
Family M/Ns	N/A
S/N	N/A
Operating Freq	896-901, 902-930, 935-940 MHz
Max. Output Power	80.0 W
Modulation	N/A Amplifier
Power Source	13.8 VDC DC Power
Test Item	Preproduction
Type of DUT	Fixed/Mobile Amplifier

Applicant: Crescend Technolgoies LLC
FCC ID: CWWP8XXL1
IC: 7291A-P8XXL1
MODEL #: P8 SERIES 900
Report: Z:\C\CRESCEND_CWW\1396AT10\Extra1396AT10\1396AT10TestReport.doc



TEST EQUIPMENT

Device	Manufacturer	Model	Serial Number	Cal/Char Date	Due Date
Analyzer Tan Tower Spectrum Analyzer	HP	8566B Opt 462	3138A07786 3144A20661	CAL 12/7/09	12/7/11
Analyzer Tan Tower RF Preselector	HP	85685A	3221A01400	CAL 12/7/09	12/7/11
Analyzer Tan Tower Quasi-Peak Adapter	HP	85650A	3303A01690	CAL 12/8/09	12/8/11
Analyzer Tan Tower Preamplifier	HP	8449B-H02	3008A00372	CAL 12/8/09	12/8/11
Antenna: Biconnical	Electro-Metrics	BIA-25	1171	CAL 4/29/09	4/29/11
Antenna: Log-Periodic	Electro-Metrics	LPA-25	1122	CAL 12/1/08	12/1/10
Antenna: Double-Ridged Horn	Electro-Metrics	RGA-180	2319	CAL 12/29/08	12/29/10
LISN	Electro-Metrics	ANS-25/2	2604	CAL 10/5/08	10/5/10
Termaline Wattmeter	Bird Electronic Corporation	611	16405	CAL 3/15/09	3/15/11

Applicant: Crescend Technolgoies LLC
 FCC ID: CWWP8XXL1
 IC: 7291A-P8XXL1
 MODEL #: P8 SERIES 900
 Report: Z:\C\CRESCEND_CWW\1396AT10\Extra1396AT10\1396AT10TestReport.doc

TEST PROCEDURES

Power Line Conducted Interference

The procedure used was ANSI 63.4-2003 using a 50uH LISN. Both lines were observed with the DUT transmitting. The bandwidth of the spectrum analyzer was 10 kHz with an appropriate sweep speed.

RF Power Output

The RF power output was measured at the antenna feed point using a peak power meter. A 50-ohm, resistive wattmeter was connected to the RF output connector. With a nominal battery voltage, and the transmitter properly adjusted the RF output measures:

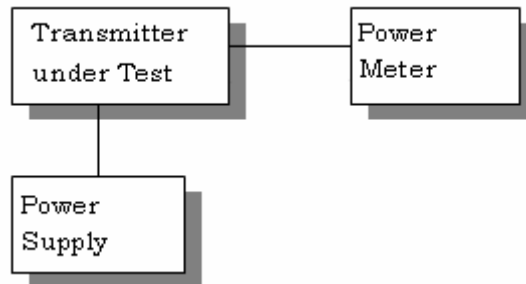

Spurious Emissions At Antenna Terminals (Conducted)

The carrier was modulated 100%. The spectrum was scanned from 0.4 to at least the 10th harmonic of the fundamental. Above 1 GHz the resolution bandwidth was 1 MHz and the VBW = 3 MHz and the span to 50 MHz. The measurements were made in accordance with standard ANSI/TIA-603-C: 2004

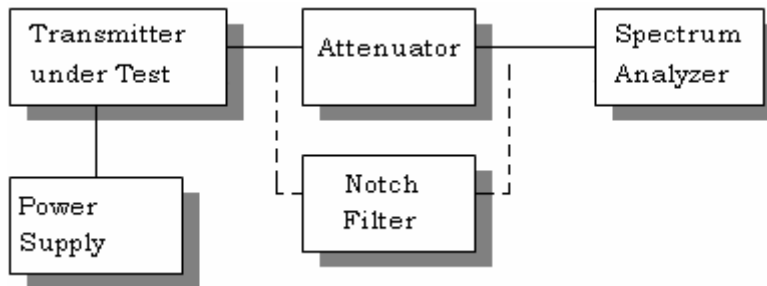

Radiation Interference

The test procedure used was ANSI/TIA-603-C: 2004 and ANSI C63.4-2003 using an Agilent spectrum receiver with pre-selector. The bandwidth (RBW) of the spectrum receiver was 100 kHz up to 1 GHz and 1 MHz above 1 GHz with an appropriate sweep speed. The VBW above 1 GHz was 3 MHz. The analyzer was calibrated in dB above a microvolt at the output of the antenna.

Applicant: Crescend Technolgoies LLC
 FCC ID: CWWP8XXL1
 IC: 7291A-P8XXL1
 MODEL #: P8 SERIES 900
 Report: Z:\C\CRESCEM\CWW\1396AT10\Extra1396AT10\1396AT10TestReport.doc

Modulation Characteristic

Audio frequency response

The audio frequency response was measured in accordance with ANSI/TIA 603-C: 2004.

Audio Low Pass Filter

The audio low pass filter for voice-modulated equipment was measured in accordance with ANSI/TIA 603-C: 2004.

Audio Input versus modulation

The audio input level needed for a particular percentage of modulation was measured in accordance with ANSI/TIA 603-C: 2004. Curves are provided for audio input frequencies of 300, 1000, and 3000 Hz.

Frequency Stability

The frequency stability was measured per ANSI/TIA 603-C: 2004.

Field Strength of Spurious Emissions

The spectrum was scanned from 30 MHz to at least the tenth harmonic of the fundamental. This test was conducted per ANSI/TIA 603-C: 2004 using the substitution method.

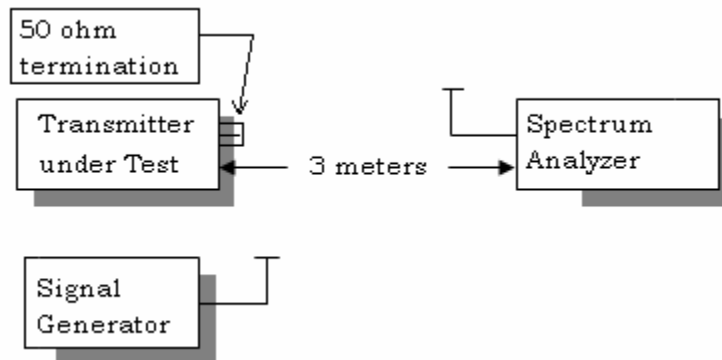

Applicant: Crescend Technolgoies LLC
 FCC ID: CWWP8XXL1
 IC: 7291A-P8XXL1
 MODEL #: P8 SERIES 900
 Report: Z:\C\CRESCEND_CWW\1396AT10\Extra1396AT10\1396AT10TestReport.doc



TEST RESULTS

RF POWER OUTPUT

Rule Part No.: Pt 2.1046(a), Pt 90, Pt 90.210, RSS-131, 4.3, 6.2

Requirements: Pt 2.1046(a), Pt 90, Pt 90.210, RSS-131, 4.3, 6.2

Test Data: Power = 80.4 W

DC Power Consumption

Vdc = 13.8 V

Ic = 19.6 Amps

Test Frequency (MHz)	Input (dBm)	Output (dBm)	Output (W)
896.00	20.85	49.05	80.4
916.00	21.02	48.94	78.3
940.00	20.71	48.77	75.3

Applicant: Crescend Technolgoies LLC
FCC ID: CWWP8XXL1
IC: 7291A-P8XXL1
MODEL #: P8 SERIES 900
Report: Z:\C\CRESCEND_CWW\1396AT10\Extra1396AT10\1396AT10TestReport.doc

INPUT/OUTPUT COMPARISON:

	Ref Lvl	Marker 1 [T3]	RBW	3 kHz	RF Att	20 dB
	55 dBm	48.32 dBm	VBW	3 kHz		
		896.99539078 MHz	SWT	56 ms	Unit	dBm

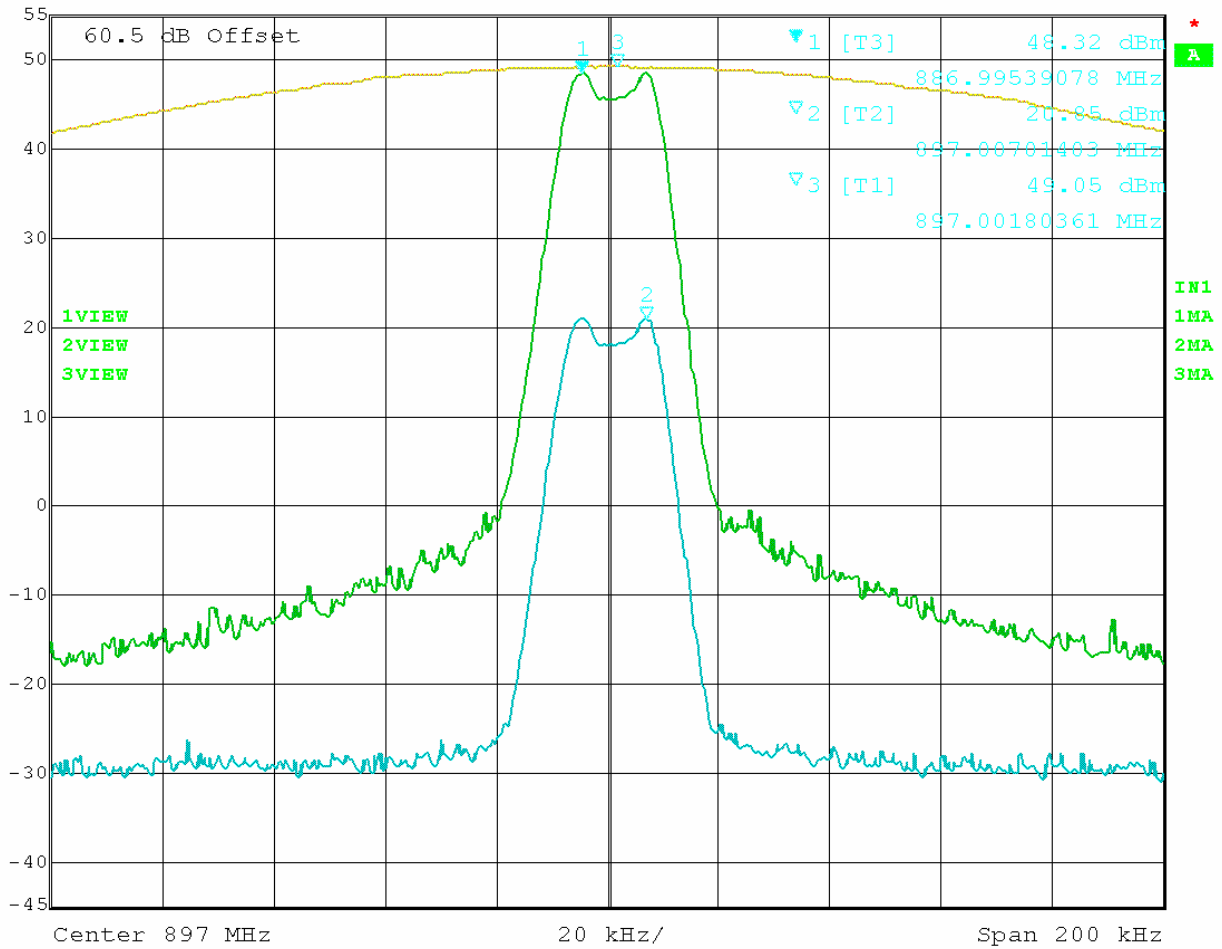

Date: 15.JUL.2010 13:56:13

Applicant: Crescend Technolgoies LLC
 FCC ID: CWWP8XXL1
 IC: 7291A-P8XXL1
 MODEL #: P8 SERIES 900
 Report: Z:\C\CRESCEND_CWW\1396AT10\Extra1396AT10\1396AT10TestReport.doc



Marker 1 [T3] RBW 3 kHz RF Att 20 dB
 Ref Lvl 48.18 dBm VBW 3 kHz
 55 dBm 916.00701403 MHz SWT 56 ms Unit dBm

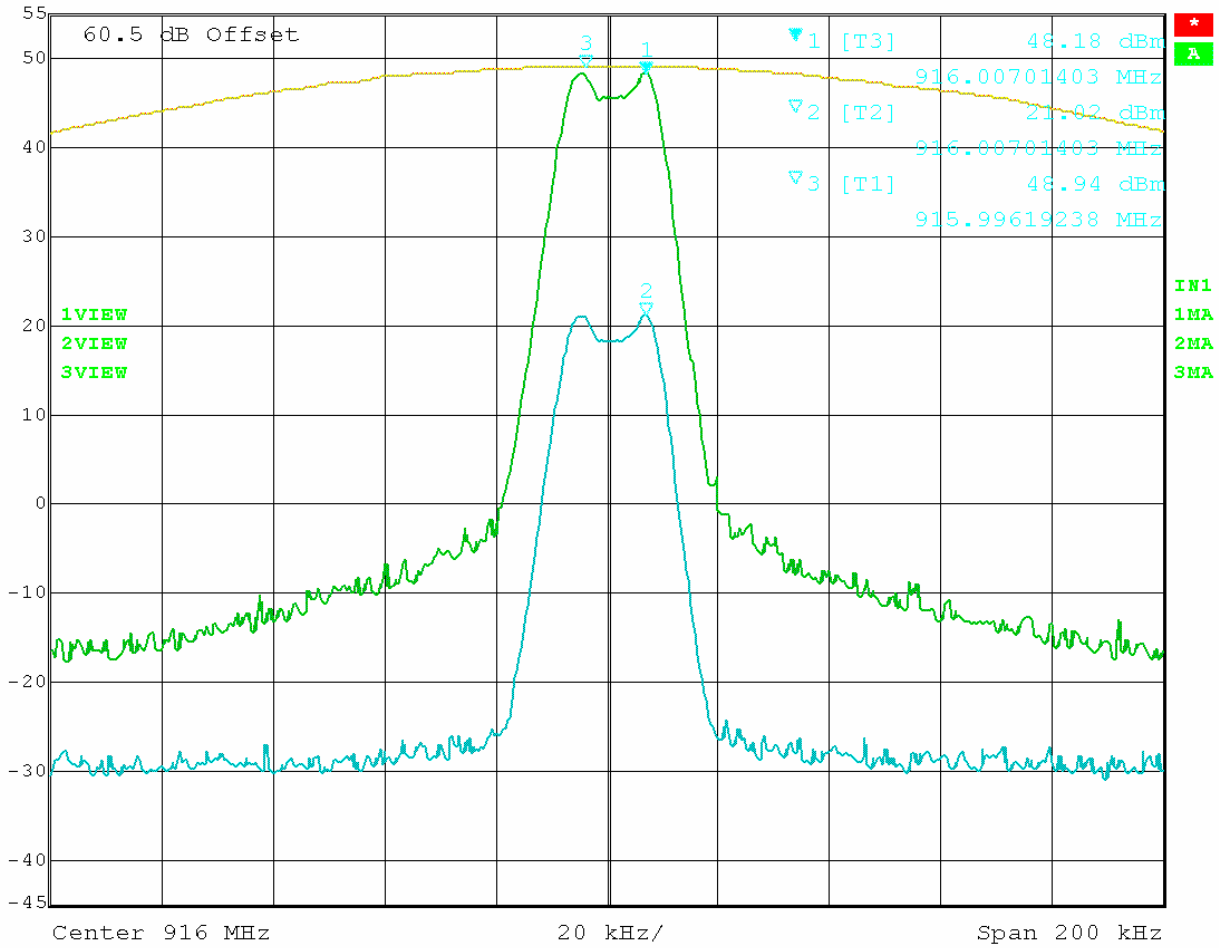

Date: 15.JUL.2010 14:00:59

Applicant: Crescend Technolgoies LLC
 FCC ID: CWWP8XXL1
 IC: 7291A-P8XXL1
 MODEL #: P8 SERIES 900
 Report: Z:\C\CRESCEND_CWW\1396AT10\Extra1396AT10\1396AT10TestReport.doc



Marker 1 [T3] RBW 3 kHz RF Att 20 dB
 Ref Lvl 48.02 dBm VBW 3 kHz
 55 dBm 938.99539078 MHz SWT 56 ms Unit dBm

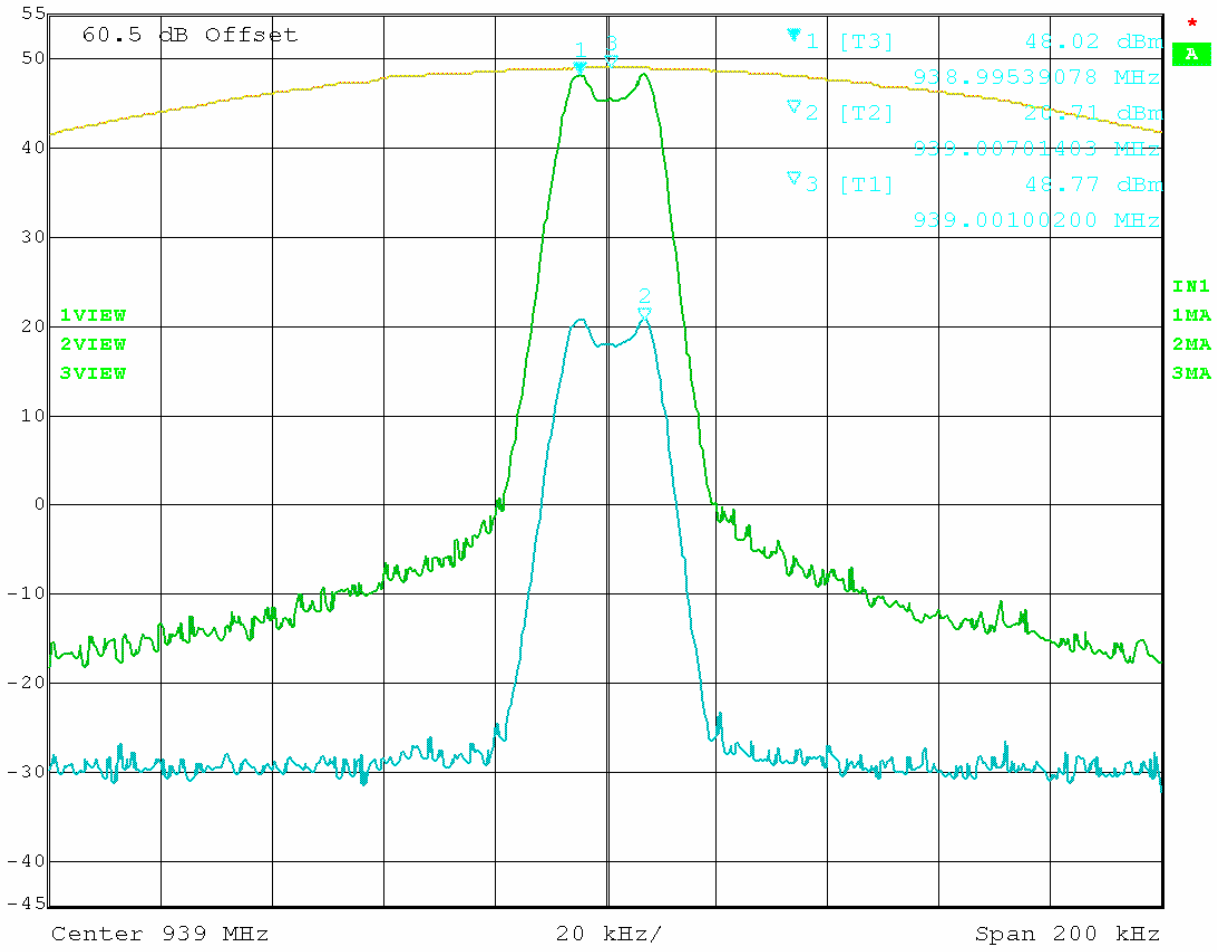

Date: 15.JUL.2010 14:08:29

Applicant: Crescent Technolgoies LLC
 FCC ID: CWWP8XXL1
 IC: 7291A-P8XXL1
 MODEL #: P8 SERIES 900
 Report: Z:\C\CRESCEND_CWW\1396AT10\Extra1396AT10\1396AT10TestReport.doc

OCCUPIED BANDWIDTH

Rule Parts No: Pt 2.1049, Pt 90.210(b), RSS-131, 4.3, 6.3

Test Requirement:

Part 90.210(b) 25kHz Channel Spacing

Data in the plots show that on any frequency removed from the assigned frequency by more than 50%, but not more than 100%: At least 25dB. On any frequency removed from the assigned frequency by more than 100%, but not more than 250%: At least 35 dB. On any frequency removed from the assigned frequency by more than 250%, of the authorized bandwidth: At least $43 + 10\log(P)$ dB.

Part 90.210(c) 12.5kHz Channel Spacing Not Equipped with a Low Pass Filter

For transmitters that are not equipped with an audio low pass filter pursuant to S90.211 (b), the power of any emission must be attenuated below the un-modulated carrier output power as follows; (1) On any frequency removed from the center of the authorized bandwidth by a displacement frequency (f_d in kHz) of more than 5 kHz but not more than 10 kHz: At least $83 \log(f_d/5)$ dB; (2) ON any frequency removed from the center of the authorized bandwidth by a displacement frequency (f_d in kHz) of more than 10 kHz, but not more than 250% of the authorized bandwidth: At least $29 \log(f_d^2/11)$ dB or 50 dB, whichever is the lesser attenuation; (3) On any frequency removed from the center of the authorized bandwidth by more than 250% of the authorized bandwidth: At least $43+10 \log(P_0)$ dB.

Part 90.210(i) Emission Mask I - 15 kHz channel BW equipment.

For transmitters that are equipped with an audio low pass filter, the power of any emission must be attenuated below the unmodulated carrier power (P) of the transmitter as follows:

- (1) On any frequency from the center of the authorized bandwidth by a displacement frequency of more than 6.8 kHz, but less than 9.0 kHz: At least 25 dB;
- (2) On any frequency from the center of the authorized bandwidth by a displacement frequency (f_d in kHz) of more than 9.0 kHz but no more than 15 kHz: At least 35 dB.
- (3) On any frequency removed from the center of the authorized bandwidth by a displacement frequency (f_d in kHz) of more than 15 kHz: At least $43 + 10\log(P)$ dB or 70 dB, whichever is the lesser attenuation.

Applicant: Crescend Technolgoies LLC
FCC ID: CWWP8XXL1
IC: 7291A-P8XXL1
MODEL #: P8 SERIES 900
Report: Z:\C\CRESCEND_CWW\1396AT10\Extra1396AT10\1396AT10TestReport.doc



SPURIOUS EMISSIONS AT ANTENNA TERMINALS (CONDUCTED)

Rule Part No.: FCC Pt 2.1051(a), IC RSS-131, 6.4

Requirements: $43+10\log(P_o) = 43+10\log(80) = 62.0$ dB
 $50+10\log(P_o) = 50+10\log(80) = 69.0$ dB

Test Data:

Emission MHz	dBc
896.00	
1792.00	83.8
2688.00	81.8
3584.00	85.1
4480.00	84.1
5376.00	83.1
6272.00	81.3
7168.00	81.1
8064.00	81.3
8960.00	81.7

Emission MHz	dBc
916.00	
1832.00	83.8
2748.00	83.0
3664.00	83.3
4580.00	84.2
5496.00	81.7
6412.00	80.5
7328.00	80.8
8244.00	81.3
9160.00	81.7

Emission MHz	dBc
940.00	
1880.00	84.0
2820.00	83.9
3760.00	83.8
4700.00	84.4
5640.00	80.4
6580.00	79.0
7520.00	80.0
8460.00	82.1
9400.00	81.6

* Emissions are in the noise level and not reported.

Applicant: Crescend Technolgoies LLC
 FCC ID: CWWP8XXL1
 IC: 7291A-P8XXL1
 MODEL #: P8 SERIES 900
 Report: Z:\C\CRESCEND_CWW\1396AT10\Extra1396AT10\1396AT10TestReport.doc



FIELD STRENGTH OF SPURIOUS EMISSIONS (RADIATED)

Rule Parts. No.: FCC Pt 2.1053, IC RSS-131, 6.4

Requirements: Same as conducted emissions

Test Data:

Emission Frequency MHz	Ant. Polarity	dB Below Carrier (dBc)
896.00	0	0
1792.00	V	95.97
2688.00	V	86.45
3584.00	V	85.65
4480.00	H	99.03
5376.00	V	96.20
6272.00	H	96.77
7168.00	H	98.88
8064.00	H	98.14
8960.00	H	95.66

Emission Frequency MHz	Ant. Polarity	dB Below Carrier (dBc)
916.00	0	0
1832.00	H	89.97
2748.00	H	90.34
3664.00	H	90.75
4580.00	H	100.10
5496.00	V	94.48
6412.00	H	99.39
7328.00	H	98.50
8244.00	V	99.95
9160.00	H	94.96

Emission Frequency MHz	Ant. Polarity	dB Below Carrier (dBc)
940.00	0	0
1880.00	V	91.22
2820.00	V	88.52
3760.00	H	90.06
4700.00	V	97.73
5640.00	V	87.27
6580.00	H	98.13
7520.00	H	98.17
8460.00	H	97.03
9400.00	H	92.55

* Emissions are in the noise level and not reported.

Applicant: Crescend Technolgoies LLC
 FCC ID: CWWP8XXL1
 IC: 7291A-P8XXL1
 MODEL #: P8 SERIES 900
 Report: Z:\C\CRESCEND_CWW\1396AT10\Extra1396AT10\1396AT10TestReport.doc

POWER LINE CONDUCTED INTERFERENCE

Rules Part No.: FCC Pt 15.207, IC RSS-GEN

Requirements:

Frequency (MHz)	Quasi Peak Limits (dB μ V)	Average Limits (dB μ V)
0.15 – 0.5	66 – 56 *	56 – 46 *
0.5 – 5.0	56	46
5.0 – 30	60	50
* Decreases with logarithm of frequency		

Test Data: Not applicable DUT is battery operated exclusively.

Applicant: Crescend Technolgoies LLC
 FCC ID: CWWP8XXL1
 IC: 7291A-P8XXL1
 MODEL #: P8 SERIES 900
 Report: Z:\C\CRESCEND_CWW\1396AT10\Extra1396AT10\1396AT10TestReport.doc